



**THE DATASHEET OF
40193BCN**



CD40193BC

Synchronous 4-Bit Up/Down Binary Counter

General Description

The CD40193BC up/down counter is monolithic complementary MOS (CMOS) integrated circuits. The CD40193BC is a binary counter.

Counting up and counting down is performed by two count inputs, one being held HIGH while the other is clocked. The outputs change on the positive-going transition of this clock.

These counters feature preset inputs that are enabled when load is a logical "0" and a clear which forces all outputs to "0" when it is at logical "1". The counters also have carry and borrow outputs so that they can be cascaded using no external circuitry.

All inputs are protected against damage due to static discharge by clamps to V_{DD} and V_{SS} .

Features

- Wide supply voltage range: 3V to 15V
- High noise immunity: $0.45 V_{DD}$ (typ.)
- Low power TTL compatibility: Fan out of 2 driving 74L or 1 driving 74LS
- Carry and borrow outputs for easy expansion to N-bit by cascading
- Asynchronous clear

Ordering Code:

Order Number	Package Number	Package Description
CD40193BCM	M16A	16-Lead Small Outline Integrated Circuit (SOIC), JEDEC MS-012, 0.150" Narrow
CD40193BCN	N16E	16-Lead Plastic Dual-In-Line Package (PDIP), JEDEC MS-001, 0.300" Wide

Connection Diagram

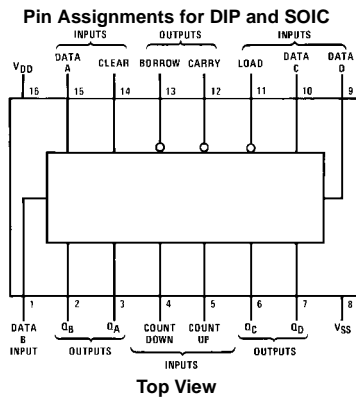

Cascading Packages

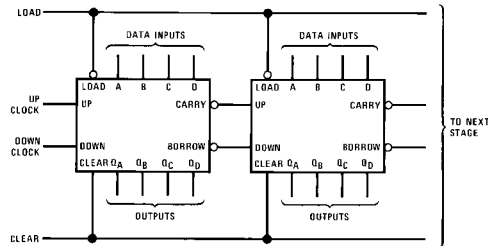

Block Diagram

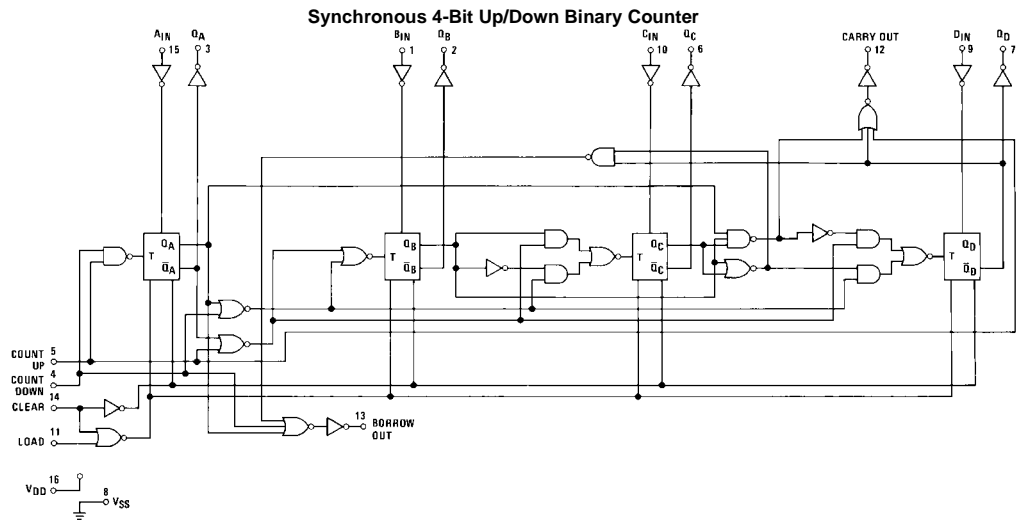

Absolute Maximum Ratings (Note 1)

(Note 2)

DC Supply Voltage (V_{DD})	-0.5 to +18 V_{DC}
Input Voltage (V_{IN})	-0.5 to V_{DD} +0.5 V_{DC}
Storage Temperature Range (T_S)	-65°C to +150°C
Power Dissipation (P_D)	
Dual-In-Line	700 mW
Small Outline	500 mW
Lead Temperature (T_L)	
(Soldering, 10 seconds)	260°C

Recommended Operating Conditions (Note 2)

DC Supply Voltage (V_{DD})	3 to 15 V_{DC}
Input Voltage (V_{IN})	0 to V_{DD} V_{DC}
Operating Temperature Range (T_A)	-55°C to +125°C

Note 1: "Absolute Maximum Ratings" are those values beyond which the safety of the device cannot be guaranteed. They are not meant to imply that the devices should be operated at these limits. The "Recommended Operating Conditions" and Electrical Characteristics tables provide conditions for actual device operation.

Note 2: $V_{SS} = 0V$ unless otherwise specified.

DC Electrical Characteristics (Note 3)

Symbol	Parameter	Conditions	-55°C		+25°C			+125°C		Units
			Min	Max	Min	Typ	Max	Min	Max	
I_{DD}	Quiescent Device Current	$V_{DD} = 5V, V_{IN} = V_{DD}$ or V_{SS}		5			5		150	μA
		$V_{DD} = 10V, V_{IN} = V_{DD}$ or V_{SS}		10			10		300	
		$V_{DD} = 15V, V_{IN} = V_{DD}$ or V_{SS}		20			20		600	
V_{OL}	LOW Level Output Voltage	$V_{DD} = 5V$		0.05			0.05		0.05	V
		$V_{DD} = 10V$		0.05			0.05		0.05	
		$V_{DD} = 15V$		0.05			0.05		0.05	
V_{OH}	HIGH Level Output Voltage	$V_{DD} = 5V$	4.95		4.95			4.95		V
		$V_{DD} = 10V$	9.95		9.95			9.95		
		$V_{DD} = 15V$	14.95		14.95			14.95		
V_{IL}	LOW Level Input Voltage	$V_{DD} = 5V, V_O = 0.5V$ or 4.5V		1.5			1.5		1.5	V
		$V_{DD} = 10V, V_O = 1V$ or 9V		3.0			3.0		3.0	
		$V_{DD} = 15V, V_O = 1.5V$ or 13.5V		4.0			4.0		4.0	
V_{IH}	HIGH Level Input Voltage	$V_{DD} = 5V, V_O = 0.5V$ or 4.5V	3.5		3.5			3.5		V
		$V_{DD} = 10V, V_O = 1V$ or 9V	7.0		7.0			7.0		
		$V_{DD} = 15V, V_O = 1.5V$ or 13.5V	11.0		11.0			11.0		
I_{OL}	LOW Level Output Current <small>(Note 4)</small>	$V_{DD} = 5V, V_O = 0.4V$	0.64		0.51	0.88		0.36		mA
		$V_{DD} = 10V, V_O = 0.5V$	1.6		1.3	2.25		0.9		
		$V_{DD} = 15V, V_O = 1.5V$	4.2		3.4	8.8		2.4		
I_{OH}	HIGH Level Output Current <small>(Note 4)</small>	$V_{DD} = 5V, V_O = 4.6V$	-0.64		-0.51	-0.88		-0.36		mA
		$V_{DD} = 10V, V_O = 9.5V$	-1.6		-1.3	-2.25		-0.9		
		$V_{DD} = 15V, V_O = 13.5V$	-4.2		-3.4	-8.8		-2.4		
I_{IN}	Input Current	$V_{DD} = 15V, V_{IN} = 0V$		-0.1		-10^{-5}	-0.1		-1.0	μA
		$V_{DD} = 15V, V_{IN} = 15V$		0.1		10^{-5}	0.1		1.0	

Note 3: AC Parameters are guaranteed by DC correlated testing.

Note 4: I_{OH} and I_{OL} are tested one output at a time.

AC Electrical Characteristics (Note 3)T_A = 25°C, C_L = 50 pF, R_L = 200 kΩ, input t_r = t_f = 20 ns, unless otherwise specified.

Symbol	Parameter	Conditions	Min	Typ	Max	Units
t _{PHL} or t _{PLH}	Propagation Delay Time from Count Up or Count Down to Q	V _{DD} = 5V V _{DD} = 10V V _{DD} = 15V		250 100 80	400 160 130	ns
t _{PHL} or t _{PLH}	Propagation Delay Time from Count Up to Carry	V _{DD} = 5V V _{DD} = 10V V _{DD} = 15V		120 50 40	200 80 65	ns
t _{PHL} or t _{PLH}	Propagation Delay Time from Count Down to Borrow	V _{DD} = 5V V _{DD} = 10V V _{DD} = 15V		120 50 40	200 80 65	ns
t _{SU}	Time Prior to Load That Data Must Be Present	V _{DD} = 5V V _{DD} = 10V V _{DD} = 15V		100 30 25	160 50 40	ns
t _{PHL}	Propagation Delay Time from Clear to Q	V _{DD} = 5V V _{DD} = 10V V _{DD} = 15V		130 60 50	220 100 80	ns
t _{PLH} or t _{PHL}	Propagation Delay Time from Load to Q	V _{DD} = 5V V _{DD} = 10V V _{DD} = 15V		300 120 95	480 190 150	ns
t _{TLH} or t _{THL}	Output Transition Time	V _{DD} = 5V V _{DD} = 10V V _{DD} = 15V		100 50 40	200 100 80	ns
f _{CL}	Maximum Count Frequency	V _{DD} = 5V V _{DD} = 10V V _{DD} = 15V	2.5 6 7.5	4 10 12.5		MHz
t _{rCL} or t _{fCL}	Maximum Count Rise or Fall Time	V _{DD} = 5V V _{DD} = 10V V _{DD} = 15V	15 5 1			μs
t _{WH} , t _{WL}	Minimum Count Pulse Width	V _{DD} = 5V V _{DD} = 10V V _{DD} = 15V		120 35 28	200 80 65	ns
t _{WH}	Minimum Clear Pulse Width	V _{DD} = 5V V _{DD} = 10V V _{DD} = 15V		300 120 95	480 190 150	ns
t _{WL}	Minimum Load Pulse Width	V _{DD} = 5V V _{DD} = 10V V _{DD} = 15V		100 40 32	160 65 55	ns
C _{IN}	Average Input Capacitance	Load and Data Inputs (A,B,C,D) Count Up, Count Down and Clear		5 10	7.5 15	pF
C _{PD}	Power Dissipation Capacity	(Note 5)		100		pF

Note 5: C_{PD} determines the no load AC power consumption of any CMOS device. For complete explanation, see Family Characteristics application note, AN-90.

Timing Diagrams

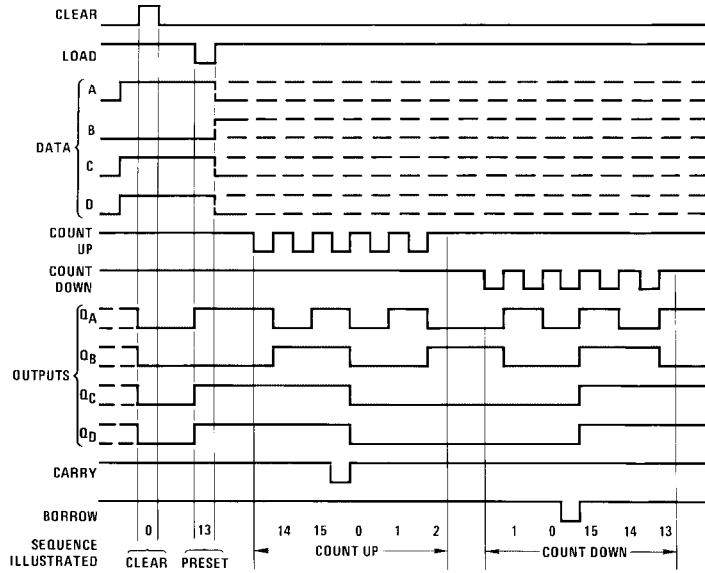

Sequence:

1. Clear outputs to zero.
2. Load (preset) to binary thirteen.
3. Count up to fourteen, fifteen, carry, zero, one and two.
4. Count down to one, zero, borrow, fifteen, fourteen and thirteen.

Physical Dimensions inches (millimeters) unless otherwise noted

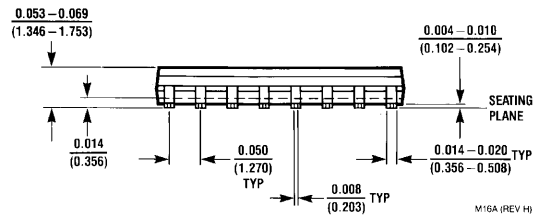
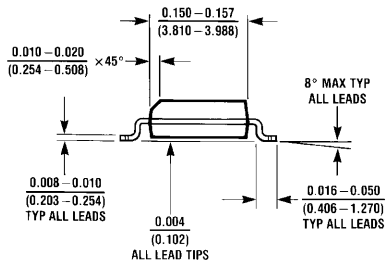
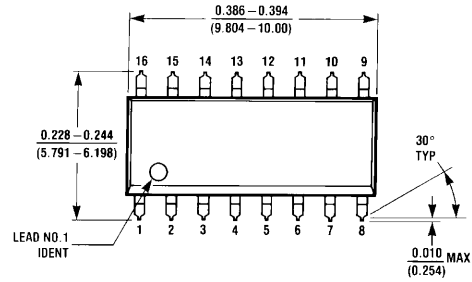

**16-Lead Small Outline Integrated Circuit (SOIC), JEDEC MS-012, 0.150" Narrow
Package Number M16A**

M16A (REV H)

Physical Dimensions inches (millimeters) unless otherwise noted (Continued)

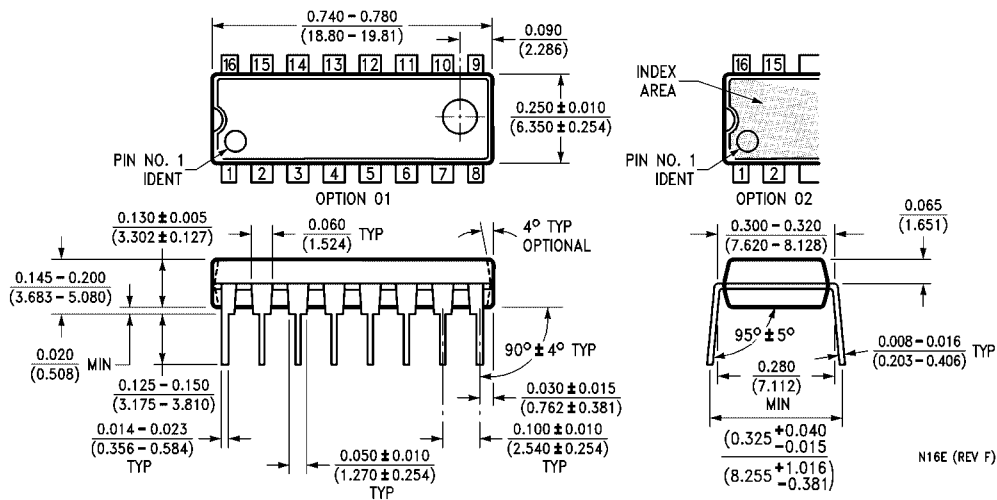

**16-Lead Plastic Dual-In-Line Package (PDIP), JEDEC MS-001, 0.300" Wide
Package Number N16E**

Fairchild does not assume any responsibility for use of any circuitry described, no circuit patent licenses are implied and Fairchild reserves the right at any time without notice to change said circuitry and specifications.

LIFE SUPPORT POLICY

FAIRCHILD'S PRODUCTS ARE NOT AUTHORIZED FOR USE AS CRITICAL COMPONENTS IN LIFE SUPPORT DEVICES OR SYSTEMS WITHOUT THE EXPRESS WRITTEN APPROVAL OF THE PRESIDENT OF FAIRCHILD SEMICONDUCTOR CORPORATION. As used herein:

1. Life support devices or systems are devices or systems which, (a) are intended for surgical implant into the body, or (b) support or sustain life, and (c) whose failure to perform when properly used in accordance with instructions for use provided in the labeling, can be reasonably expected to result in a significant injury to the user.
2. A critical component in any component of a life support device or system whose failure to perform can be reasonably expected to cause the failure of the life support device or system, or to affect its safety or effectiveness.

www.fairchildsemi.com

Looking for pricing, stock, or lifecycle information?

Click below to explore more details on WIN SOURCE:

-  [View 40193BCN on WIN SOURCE](#)
-  [Fairchild/ON Semiconductor Information](#)

Optimize Your Supply Chain with WIN SOURCE Solutions

-  Global Sourcing Solution
-  Obsolete Management
-  Cost Control Management
-  Shortage Management
-  Alternative Solution
-  Excess Inventory Management