



**THE DATASHEET OF
PI2PCIE412-DZHEX**



Enhanced, 1.8V, PCI Express Compliant, 4-Differential Channel, 2:1 Mux/DeMux Switch, w/ Single Enable

Features

- 4 Differential Channel, 2:1 Mux/DeMux
- PCI Express signal compliance
- Low Bit-to-Bit Skew , 10ps max (between '+' and '-' bits)
- Low Crosstalk: -65dB@10 MHz
- Low Off Isolation: -65dB@10 MHz
- V_{CC} Operating Range: +1.5V to +2.0V
- ESD Tolerance: 8kV HBM I/O; 2kV HBM select pin
- Low channel-to-channel skew, 35ps max
- Packaging (Pb-free & Green):
– 42-contact, TQFN (ZH42)

Description

Pericom Semiconductor's PI2PCIE412-D is an 8 to 4 differential channel multiplexer/demultiplexer switch. This solution can switch 2 full PCI Express lanes to one of two locations. Using a unique design technique, Pericom has been able to minimize the impedance of the switch such that the attenuation observed through the switch is negligible. The unique design technique also offers a layout targeted for PCI Express signals, which minimizes the channel to channel skew as well as channel to channel crosstalk as required by the PCI Express specification.

Application

Switch a PCI-Express lane output between two PCI Express lane inputs.

Block Diagram

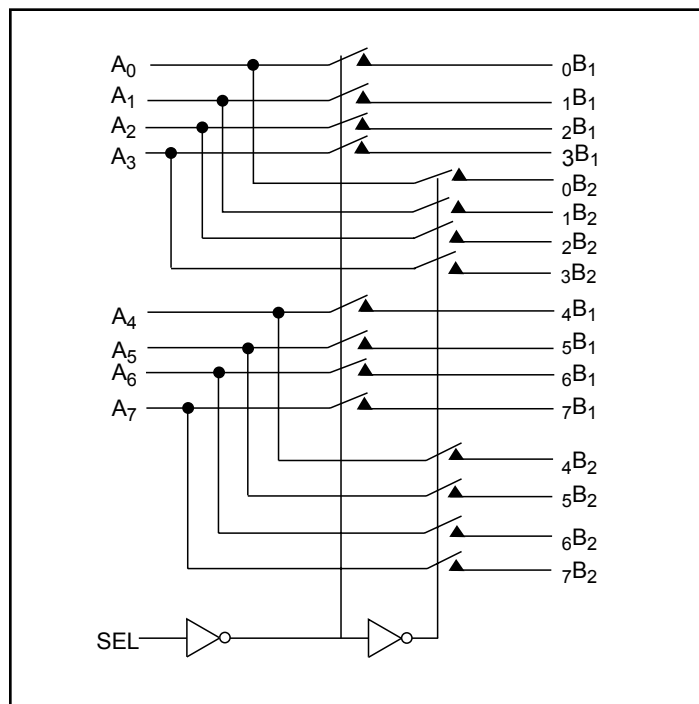

Truth Table

Function	SEL
A _N to N _B 1	L
A _N to N _B 2	H

Pin Description

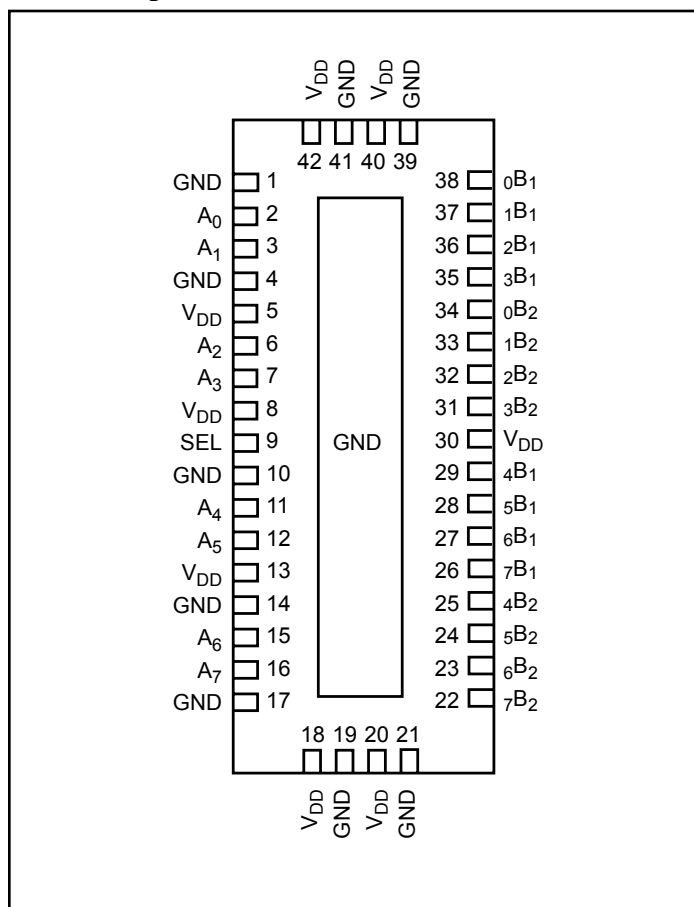

Maximum Ratings

(Above which useful life may be impaired. For user guidelines, not tested.)

Storage Temperature	-65°C to +150°C
Supply Voltage to Ground Potential	-0.5V to +2.5V
DC Input Voltage	-0.5V to V_{CC}
DC Output Current	120mA
Power Dissipation	0.5W

Note: Stresses greater than those listed under MAXIMUM RATINGS may cause permanent damage to the device. This is a stress rating only and functional operation of the device at these or any other conditions above those indicated in the operational sections of this specification is not implied. Exposure to absolute maximum rating conditions for extended periods may affect reliability.

DC Electrical Characteristics for Switching over Operating Range ($T_A = -40^\circ\text{C}$ to $+85^\circ\text{C}$, $V_{CC} = 1.5\text{V}$ to 2.0V)

Parameter	Description	Test Conditions ⁽¹⁾	Min	Typ ⁽²⁾	Max	Units
V_{IH}	Input HIGH Voltage	Guaranteed HIGH level	$0.65 \times V_{CC}$			V
V_{IL}	Input LOW Voltage	Guaranteed LOW level	-0.5		$0.35 \times V_{CC}$	
V_{IK}	Clamp Diode Voltage	$V_{CC} = \text{Max.}, I_{IN} = -18\text{mA}$		-0.7	-1.2	
I_{IH}	Input HIGH Current	$V_{CC} = \text{Max.}, V_{IN} = V_{CC}$			± 5	μA
I_{IL}	Input LOW Current	$V_{CC} = \text{Max.}, V_{IN} = \text{GND}$			± 5	

Power Supply Characteristics

Parameters	Description	Test Conditions ⁽¹⁾	Min.	Typ. ⁽²⁾	Max.	Units
I_{CC}	Quiescent Power Supply Current	$V_{CC} = \text{Max.}, V_{IN} = \text{GND or } V_{CC}$		200		μA

Dynamic Electrical Characteristics Over the Operating Range ($T_A = -40^\circ$ to $+85^\circ\text{C}$, $V_{CC} = 1.8\text{V} \pm 10\%$, $\text{GND} = 0\text{V}$)

Parameter	Description	Test Conditions	Min.	Typ. ⁽²⁾	Max.	Units
X_{TALK}	Crosstalk	See Fig. 1 for Measurement Setup, $f = 10\text{ MHz}$		-65		dB
O_{IRR}	OFF Isolation	See Fig. 2 for Measurement Setup, $f = 10\text{ MHz}$		-65		

Notes:

- For Max. or Min. conditions, use appropriate value specified under Electrical Characteristics for the applicable device type.
- Typical values are at $V_{CC} = 1.8\text{V}$, $T_A = 25^\circ\text{C}$ ambient and maximum loading.

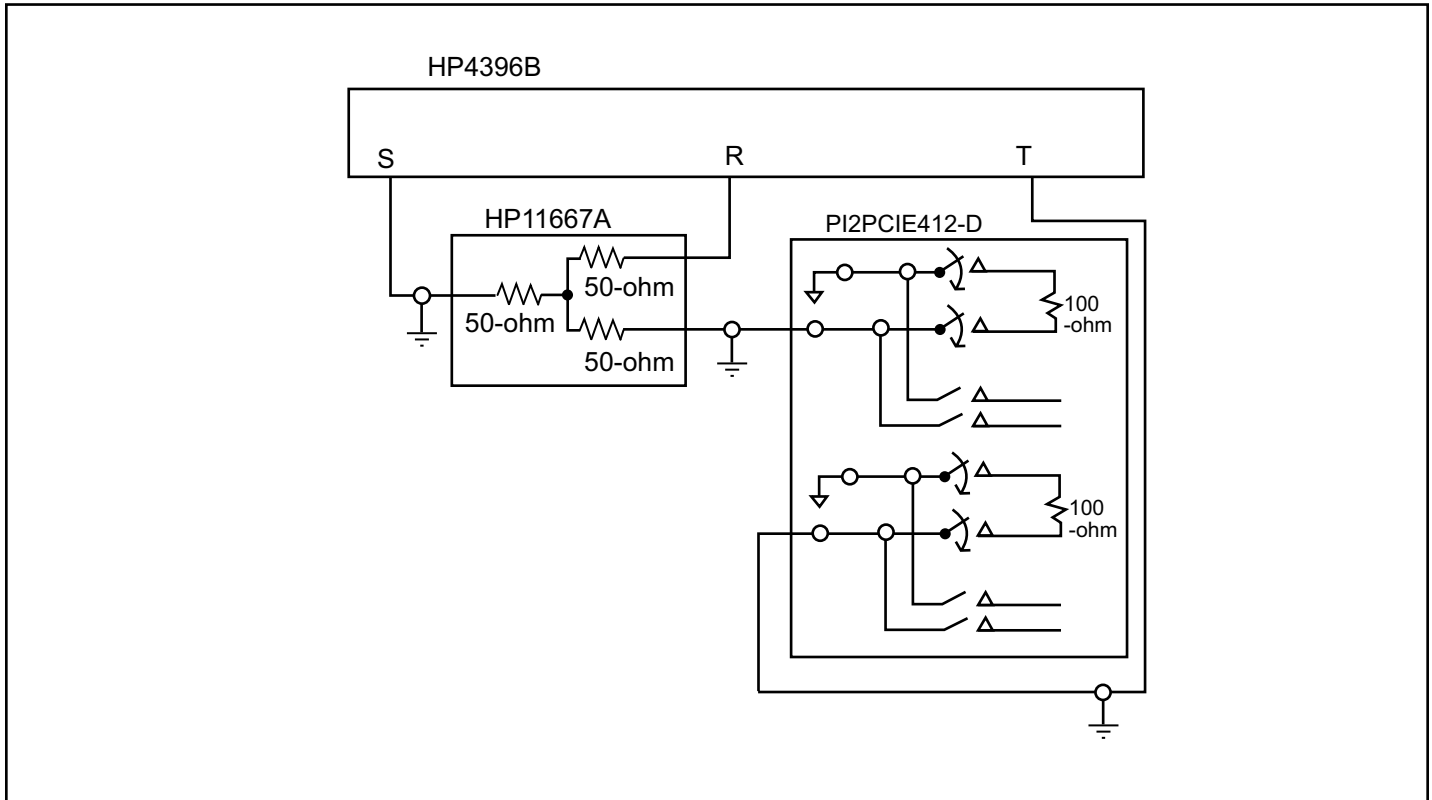

Fig 1. Crosstalk Setup

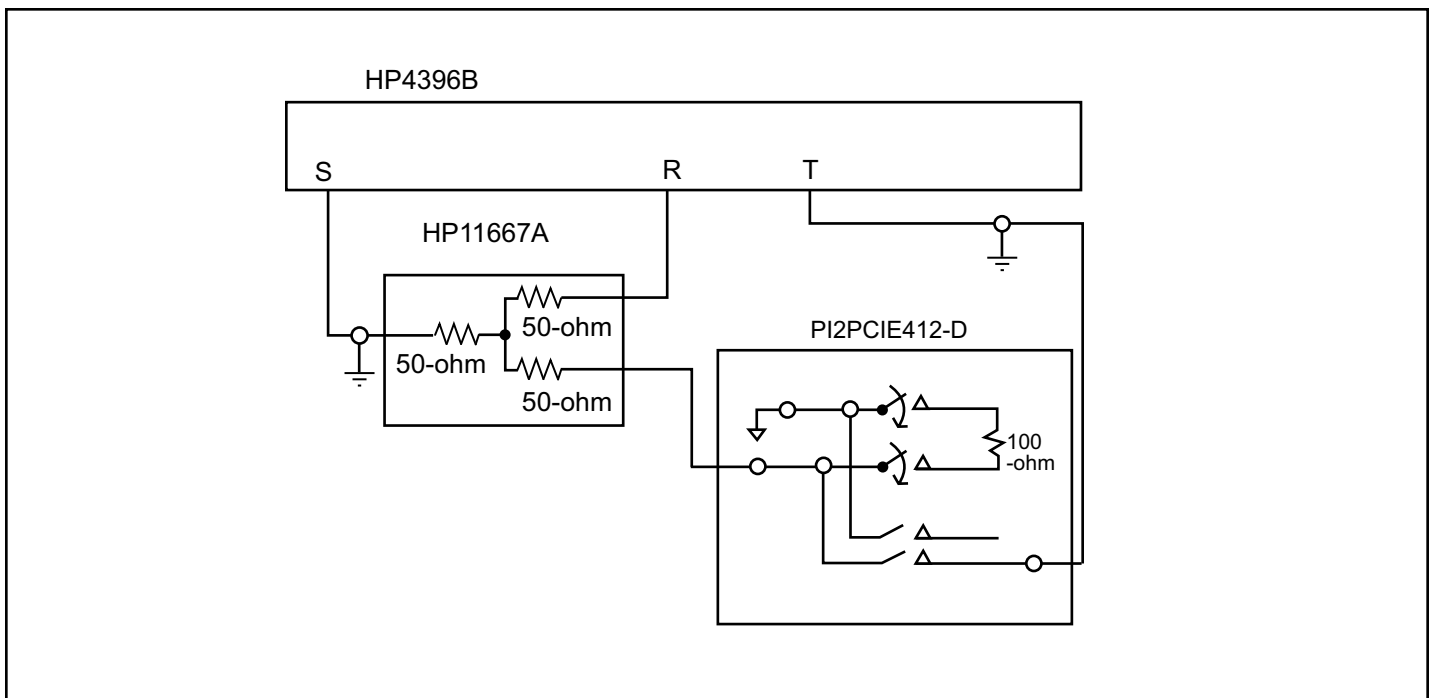

Fig 2. Off-isolation setup

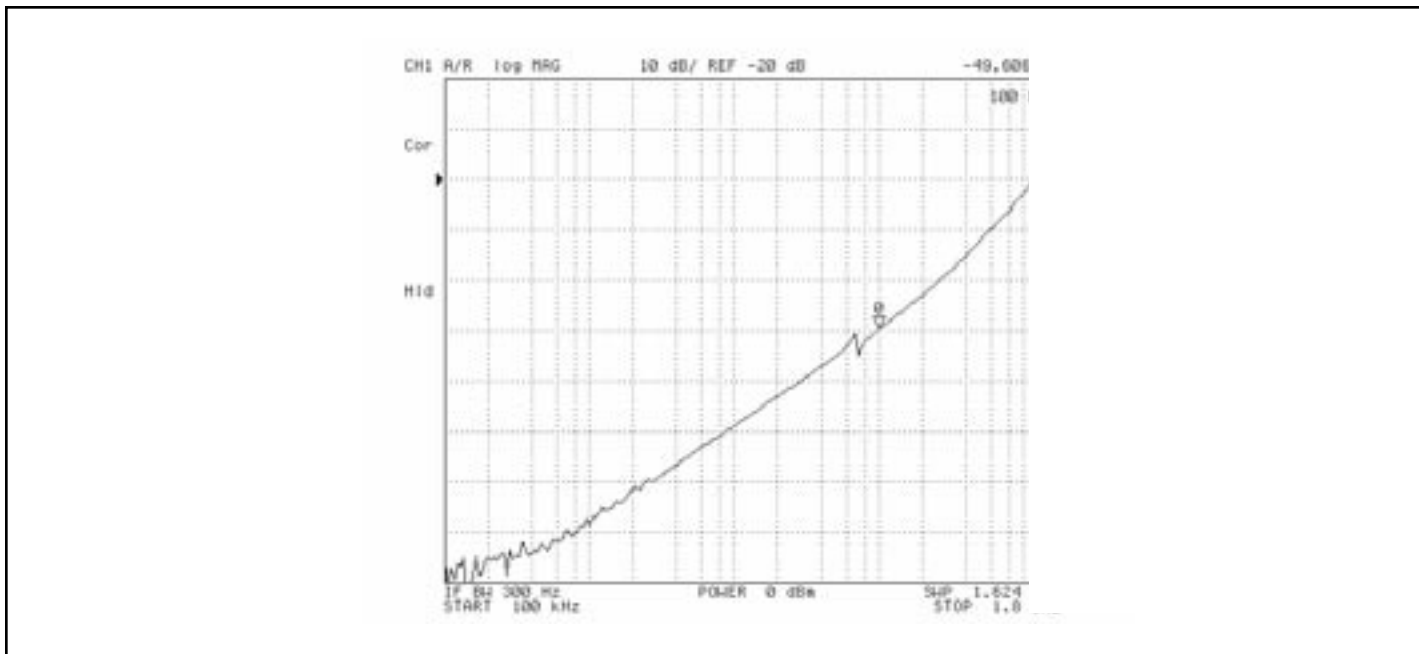

Fig 3. Crosstalk

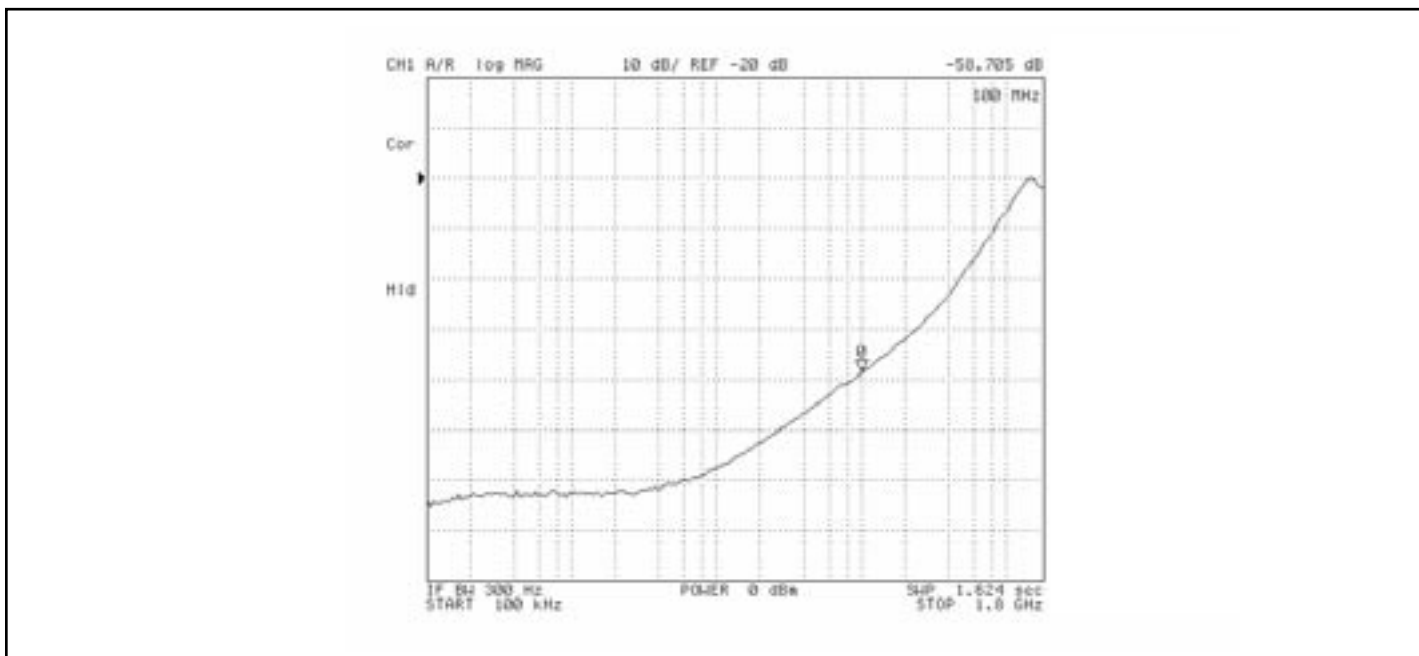
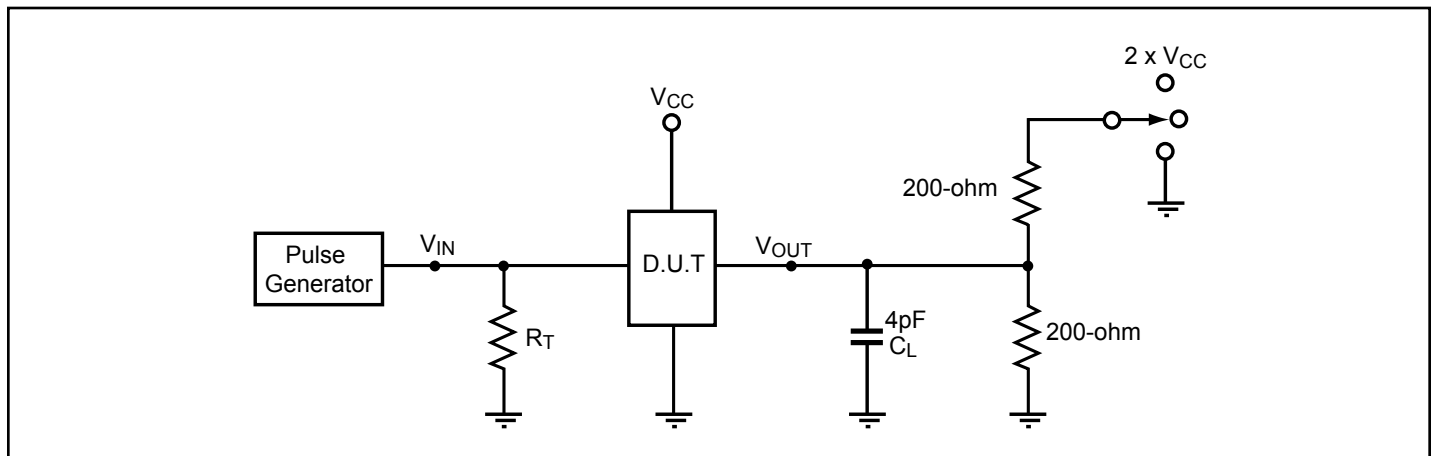

Fig 4. Off Isolation

Switching Characteristics ($T_A = -40^\circ$ to $+85^\circ\text{C}$, $V_{CC} = 1.8\text{V} \pm 10\%$)

Parameter	Description	Min.	Max.	Units
tPZH, tPZL	Line Enable Time - SEL to AN, BN	0.5	8.0	ns
tPHZ, tPLZ	Line Disable Time - SEL to AN, BN	0.5	4.0	
t _{b-b}	Bit-to-bit skew within the same differential pair		10	ps
t _{ch-ch}	Channel-to-channel skew		35	ps

Test Circuit for Electrical Characteristics⁽¹⁻⁵⁾



Notes:

1. C_L = Load capacitance: includes jig and probe capacitance.
2. R_T = Termination resistance: should be equal to Z_{OUT} of the Pulse Generator
3. Output 1 is for an output with internal conditions such that the output is low except when disabled by the output control.
output 2 is for an output with internal conditions such that the output is high except when disabled by the output control.
4. All input impulses are supplied by generators having the following characteristics: $PRR \leq \text{MHz}$, $Z_O = 50\Omega$, $t_R \leq 2.5\text{ns}$, $t_F \leq 2.5\text{ns}$.
5. The outputs are measured one at a time with one transition per measurement.

Switching Waveforms

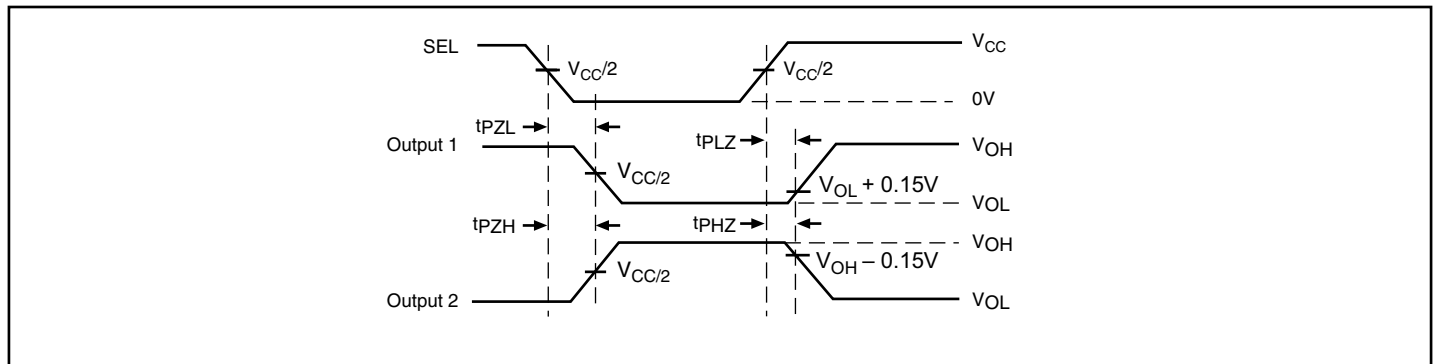

Voltage Waveforms Enable and Disable Times

Switch Positions

Test	Switch
t _{PLZ} , t _{PZL} (output on B-side)	2 x V_{CC}
t _{PHZ} , t _{PZH} (output on B-side)	GND
Prop Delay	Open

Test Circuit for Dynamic Electrical Characteristics

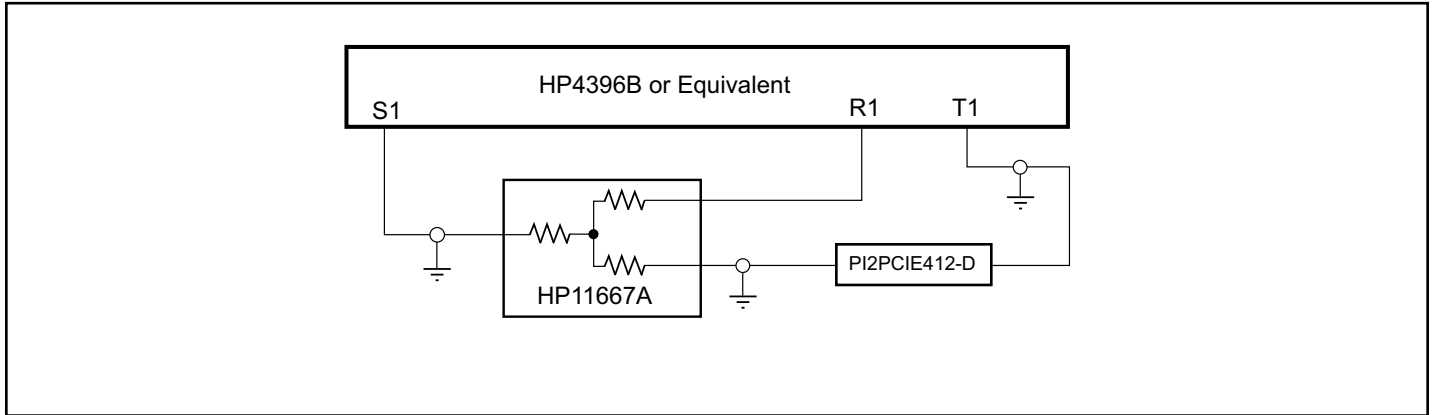

Applications Information

Rail-to-Rail is a registered trademark of Nippon Motorola, Ltd

PCI Express Application Specific Measurements and Test Set-up

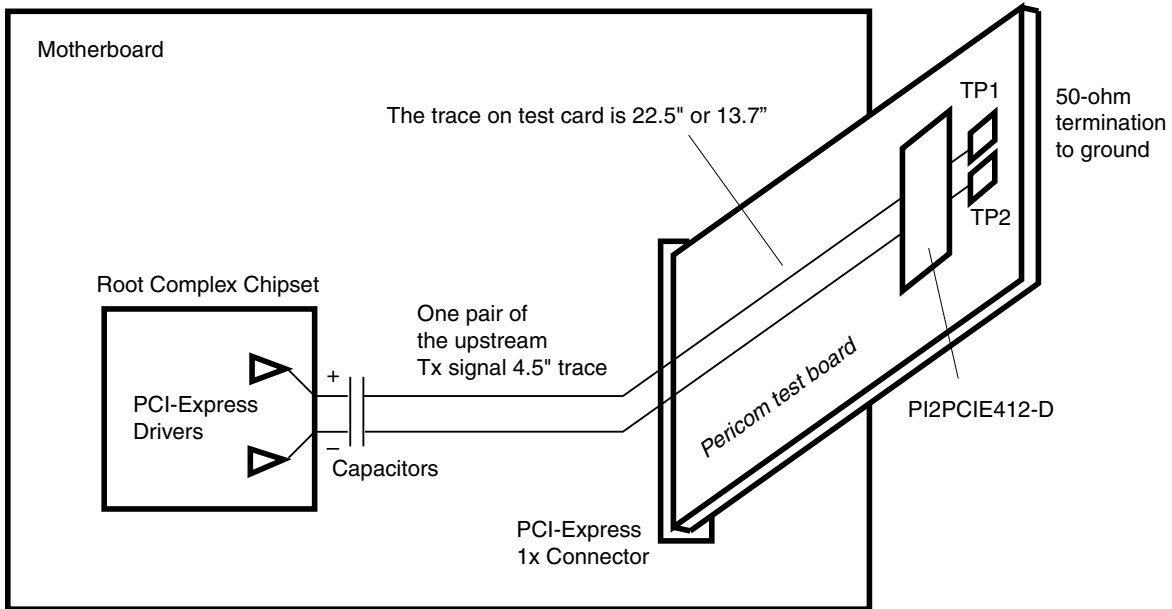

Figure 5: Test Setup

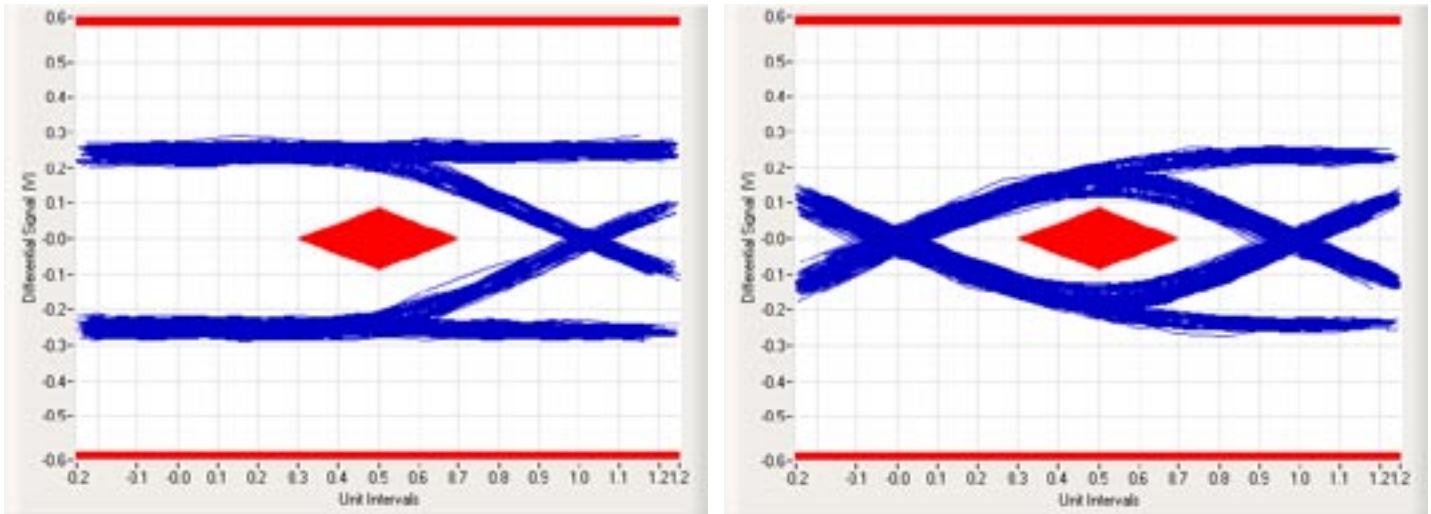

Figure 6: The worst non-transition signal eye (left) and the worst transition signal eye (right) of the PCI-SIG compliance software test using PI2PCIE412-D + 22.5" test card

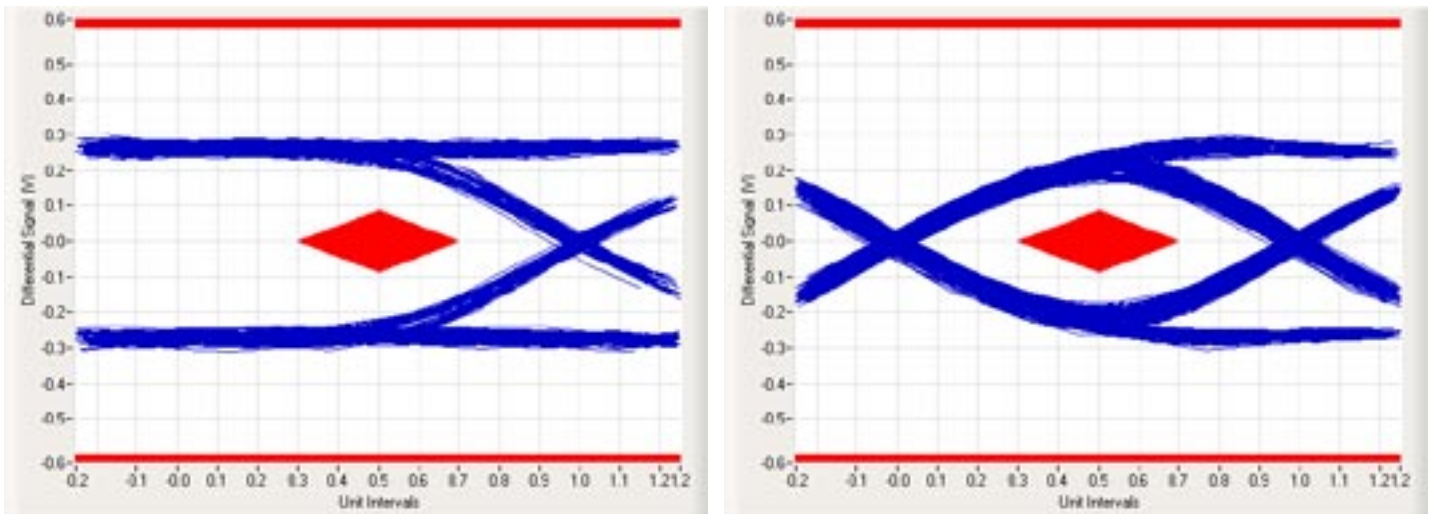

Figure 7. The worst non-transition signal eye (left) and the worst transition signal eye (right) of the PCI-SIG compliance software test with no switch + w/ 22.5" test card

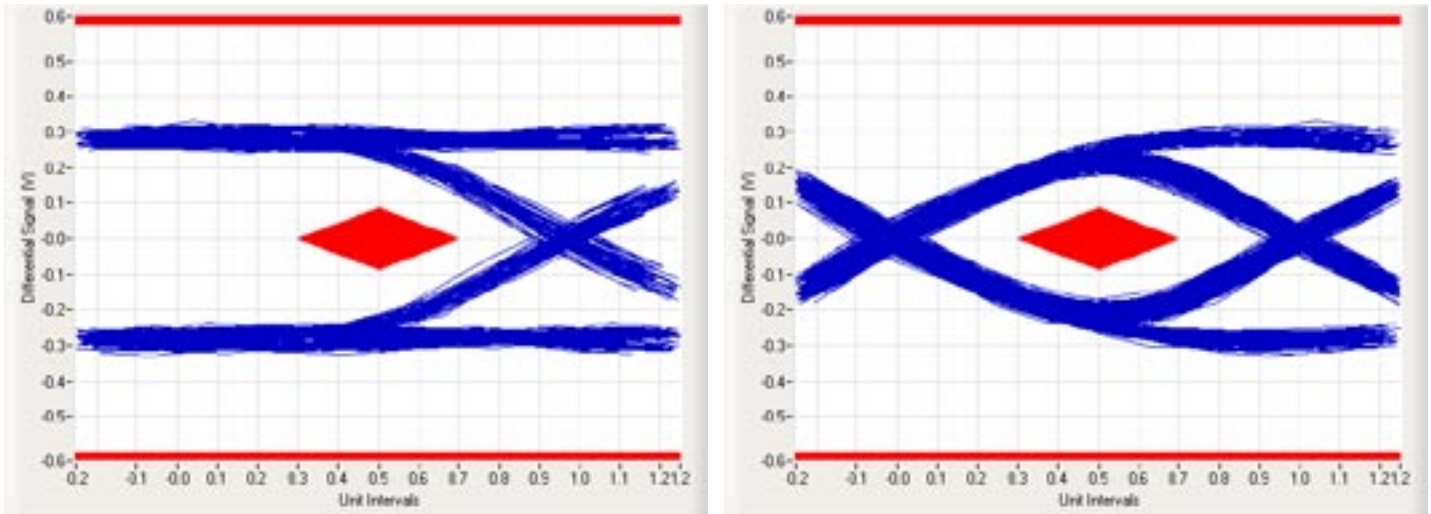

Figure 8: The worst non-transition signal eye (left) and the worst transition signal eye (right) of the PCI-SIG compliance software test using PI2PCIE412-D + 13.7" test card

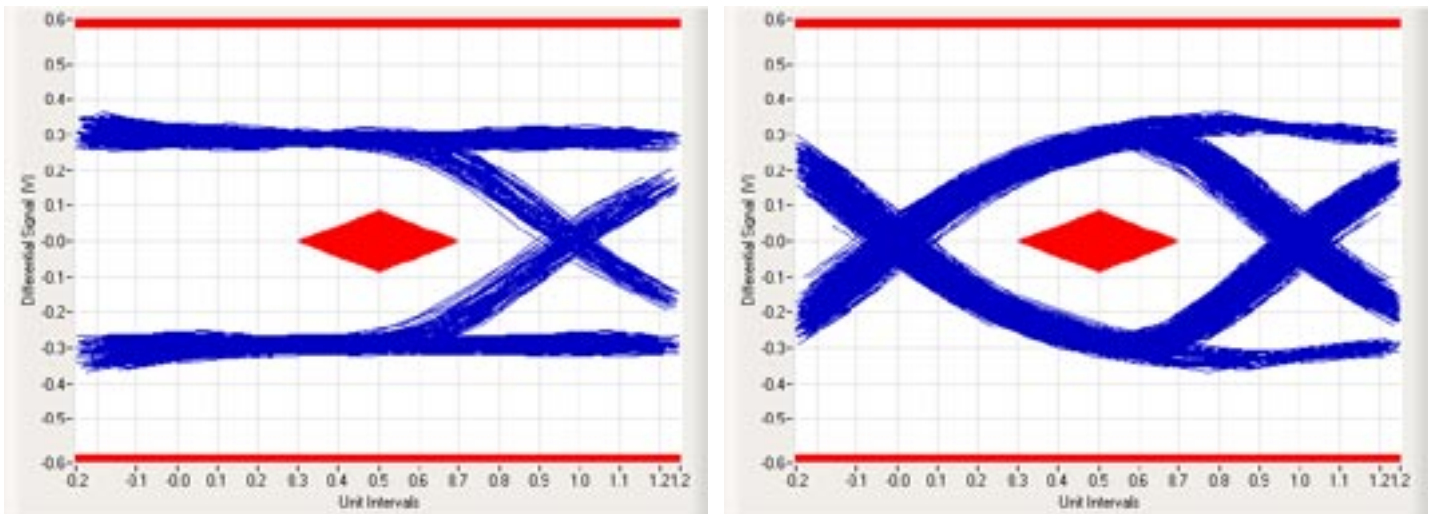
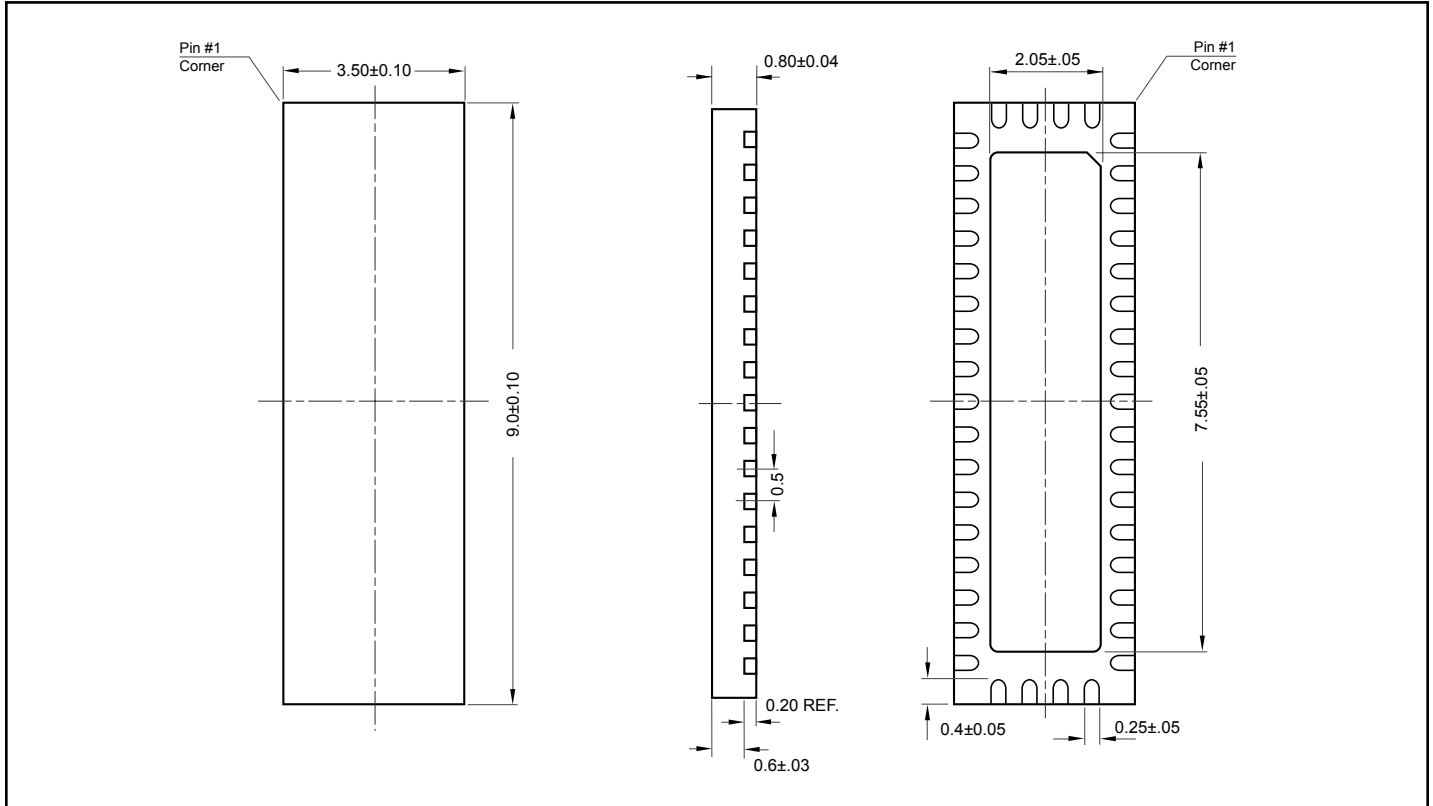

Figure 9: The worst non-transition signal eye (left) and the worst transition signal eye (right) of the PCI-SIG compliance software test with no switch + 13.7" test card

Packaging Mechanical: 42-Contact TQFN (ZH)



Ordering Information



Ordering Code	Package Code	Package Description
PI2PCIE412-DZHE	ZH	Pb-free & Green, 42-contact TQFN

Notes:

- Thermal characteristics can be found on the company web site at www.pericom.com/packaging/
- "E" denotes Pb-free and Green
- Adding an "X" at the end of the ordering code denotes tape and reel packaging

Looking for pricing, stock, or lifecycle information?

Click below to explore more details on WIN SOURCE:

-  [View PI2PCIE412-DZHEX on WIN SOURCE](#)
-  [Diodes Incorporated Information](#)

Optimize Your Supply Chain with WIN SOURCE Solutions

-  Global Sourcing Solution
-  Obsolete Management
-  Cost Control Management
-  Shortage Management
-  Alternative Solution
-  Excess Inventory Management