



# THE DATASHEET OF PGA-103+





ULTRA LINEAR LOW NOISE

# Monolithic Amplifier

## PGA-103+

50Ω 0.05 to 4 GHz

### THE BIG DEAL

- 5V/3V operation
- High IP3, 45 dBm typ. at 2 GHz, Vd=5V
- Low Noise Figure, 0.6 at 1 GHz; 0.9 dB at 2 GHz
- Gain, 11.0 dB typ. at 2 GHz
- P1dB 22.5 dBm typ. at 2 GHz at Vd=5V
- Protected under US Patent 8,803,612
- May be used as a replacement for RFMD SPF-5189Z<sup>a,b</sup>

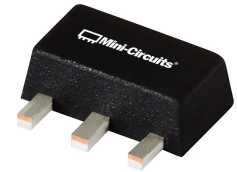

Generic photo used for illustration purposes only

CASE STYLE: DF782

#### +RoHS Compliant

The +Suffix identifies RoHS Compliance. See our web site for RoHS Compliance methodologies and qualifications

### APPLICATIONS

- Base station infrastructure
- Portable Wireless
- CATV & DBS
- MMDS & Wireless LAN
- LTE

### PRODUCT OVERVIEW

PGA-103+ (RoHS compliant) is an advanced wideband amplifier fabricated using E-PHEMT technology and offers extremely high dynamic range over a broad frequency range and with low noise figure. In addition, the PGA-103+ has good input and output return loss over a broad frequency range without the need for external matching components and has demonstrated excellent reliability. It has repeatable performance from lot to lot and is enclosed in a SOT-89 package for very good thermal performance.

### KEY FEATURES

Feature	Advantages
Broad Band: 0.05 to 4.0 GHz	Broadband covering primary wireless communications bands: Cellular, PCS, LTE, WiMAX
Ultra High IP3 Versus DC power Consumption: 45 dBm typical at 2 GHz at +5.0V Supply Voltage and only 97mA	The PGA-103+ provides excellent IP3 performance relative to device size and power consumption. The combination of the design and E-PHEMT Structure provides enhanced linearity over a broad frequency range as evidence in the IP3 being typically 20 dB above the P 1dB point. This feature makes this amplifier ideal for use in: <ul style="list-style-type: none"> <li>• Driver amplifiers for complex waveform up converter paths</li> <li>• Drivers in linearized transmit systems</li> <li>• Secondary amplifiers in ultra High Dynamic range receivers</li> </ul>
Low Noise Figure: 0.6 dB up to 1.0 GHz	A unique feature of the PGA-103+ which separates this design from all competitors is the low noise figure performance in combination with the high dynamic range.

A. Suitability for model replacement within a particular system must be determined by and is solely the responsibility of the customer based on, among other things, electrical performance criteria, stimulus conditions, application, compatibility with other components and environmental conditions and stresses.

B. The RFMD SPF-5189Z part number is used for identification and comparison purposes only.





ULTRA LINEAR LOW NOISE

# Monolithic Amplifier

PGA-103+

Mini-Circuits

**ELECTRICAL SPECIFICATIONS<sup>(1)</sup> AT 25°C, 50Ω, UNLESS NOTED OTHERWISE**

Parameter	Condition (GHz)	Vd=5V			Vd=3V	Units
		Min.	Typ.	Max.	Typ.	
Frequency Range		0.05		4.0		GHz
Gain	0.05	—	26.5	—	25.9	dB
	0.4	—	22.1	—	21.6	
	1.0	14.7	16.2	18.0	15.8	
	2.0	—	11.0	—	10.6	
	3.0	—	8.1	—	7.7	
	4.0	—	6.2	—	5.9	
Noise Figure	0.05		0.5		0.5	dB
	0.4		0.5		0.5	
	1.0		0.6		0.6	
	2.0		0.9		0.9	
	3.0		1.2		1.2	
	4.0		1.5		1.4	
Input Return Loss	0.05	—	6.7	—	6.1	dB
	0.4	—	11.3	—	10.4	
	1.0	10.0	13.0	—	12.0	
	2.0	—	12.8	—	13.0	
	3.0	—	13.7	—	13.0	
	4.0	—	15.0	—	14.2	
Output Return Loss	0.05	—	14.1	—	13.8	dB
	0.4	—	23.8	—	25.5	
	1.0	10.0	21.8	—	30.6	
	2.0	—	20.6	—	26.4	
	3.0	—	17.2	—	20.8	
	4.0	—	16.0	—	19.2	
Reverse Isolation	1.0		21.2		20.5	dB
Output Power @1 dB compression <sup>(2)</sup>	0.05		20.0		15.4	dBm
	0.4		21.5		18.2	
	1.0		22.5		18.7	
	2.0		22.5		19.3	
	3.0		22.9		20.0	
	4.0		23.2		20.7	
Output IP3	0.05	—	36.7	—	32.4	dBm
	0.4	—	39.0	—	34.1	
	1.0	—	41.9	—	34.5	
	2.0	40.0	44.6	—	35.6	
	3.0	—	44.3	—	35.6	
	4.0	—	45.4	—	35.3	
Device Operating Voltage		4.8	5.0	5.2	3.0	V
Device Operating Current			97	120	60	mA
Device Current Variation vs. Temperature			-178		-54	µA/°C
Device Current Variation vs Voltage			0.014		0.018	mA/mV
Thermal Resistance, junction-to-ground lead			36		36	°C/W

(1) Measured on Mini-Circuits Characterization test board TB-313. See Characterization Test Circuit (Fig. 1)

(2) Current increases at P1dB

**MAXIMUM RATINGS**

Parameter	Ratings
Operating Temperature (ground lead)	-40°C to 85°C
Storage Temperature	-65°C to 150°C
Operating Current at 5.0V	200 mA
Power Dissipation at 5.0V	1W
Input Power (CW)	+21 dBm (50 to 2000 MHz) +26 dBm (2000 to 4000 MHz)
DC Voltage on Pin 3	6V

Permanent damage may occur if any of these limits are exceeded.  
Electrical maximum ratings are not intended for continuous normal operation.





### SIMPLIFIED SCHEMATIC AND PIN DESCRIPTION

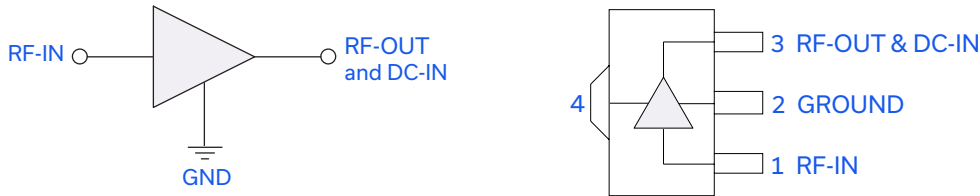

Function	Pin Number	Description
RF-IN	1	RF input pin. This pin requires the use of an external DC blocking capacitor chosen for the frequency of operation.
RF-OUT and DC-IN	3	RF output and bias pin. DC voltage is present on this pin; therefore a DC blocking capacitor is necessary for proper operation. An RF choke is needed to feed DC bias without loss of RF signal due to the bias connection, as shown in "Recommended Application Circuit", Fig. 2
GND	2,4	Connections to ground. Use via holes as shown in "Suggested Layout for PCB Design" to reduce ground path inductance for best performance.

### CHARACTERIZATION TEST CIRCUIT

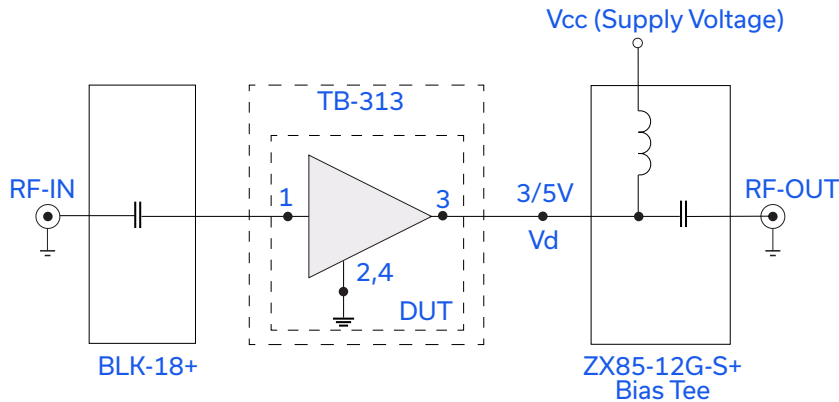

Fig 1. Block Diagram of Test Circuit used for characterization. (DUT tested on Mini-Circuits Characterization test board TB-313)  
 Gain, Return loss, Output power at 1dB compression (P1 dB), output IP3 (OIP3) and noise figure measured using Agilent's N5242A PNA-X microwave network analyzer.

- Conditions:
1. Gain and Return loss: Pin= -25dBm
  2. Output IP3 (OIP3): Two tones, spaced 1 MHz apart, 5 dBm/tone at output.



ULTRA LINEAR LOW NOISE

# Monolithic Amplifier

## PGA-103+

### RECOMMENDED APPLICATION CIRCUIT

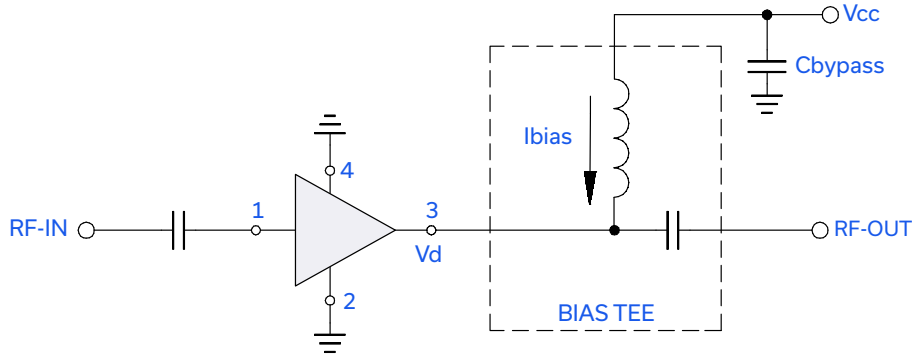

Fig 2a. Evaluation board TB-678-103+ includes case, connectors and components soldered to PCB

C<sub>block</sub>=0.001μF, Bias-Tee=TCBT-14+, C<sub>bypass</sub>=0.1μF

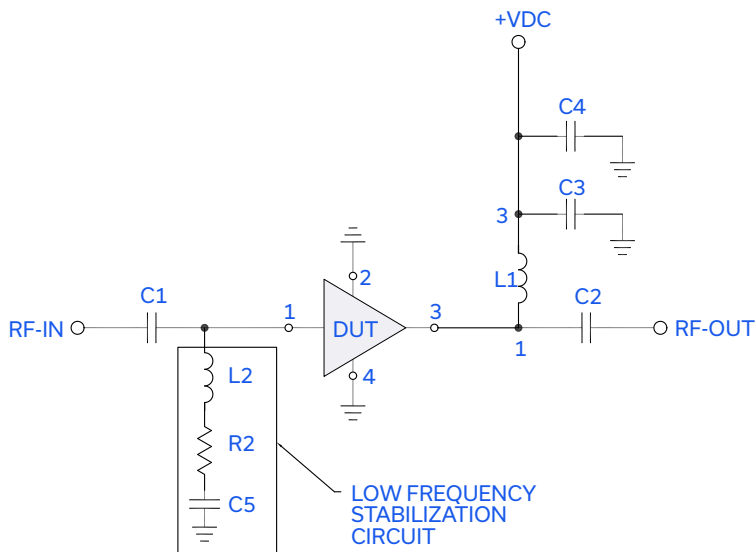
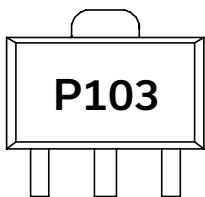

Fig 2b. Evaluation board TB-761-103+ unconditionally stable (see note AN-60-064)

SEQ	Manufacturer P/N / Value	Size
A1	PGA-103+	—
C1, C2	.01 uF	0805
C3	0.33 uF	1206
C4	10 uF	1206
C5	330 pF	0603
L1	TCCH-80+	—
L2	620 nH	.115X.110
R2	150 Ohm	0603

### PRODUCT MARKING



Marking may contain other features or characters for internal lot control





ADDITIONAL DETAILED TECHNICAL INFORMATION IS AVAILABLE ON OUR DASH BOARD. TO ACCESS [CLICK HERE](#)

Performance Data	Data Table Swept Graphs S-Parameter (S2P Files) Data Set (.zip file)
Case Style	DF782 (SOT 89) Plastic package, exposed paddle lead finish: tin-silver over nickel
Tape & Reel Standard quantities available on reel	F55 7" reels with 20, 50, 100, 200, 500 or 1K devices
Suggested Layout for PCB Design	PL-313
Evaluation Board	TB-678-103+ TB-761-103+ (see Application Note AN-60-064)
Environmental Ratings	ENV08T1

### ESD RATING

Human Body Model (HBM): Class 1A (250 to <500V) in accordance with ANSI/ESD STM 5.1 - 2001  
Machine Model (MM): Class M1(25V) in accordance with ANSI/ESD STM5.2-1999

### MSL RATING

Moisture Sensitivity: MSL1 in accordance with IPC/JEDEC J-STD-020D



#### Attention

Observe precautions for handling electrostatic sensitive devices

### MSL TEST FLOW CHART

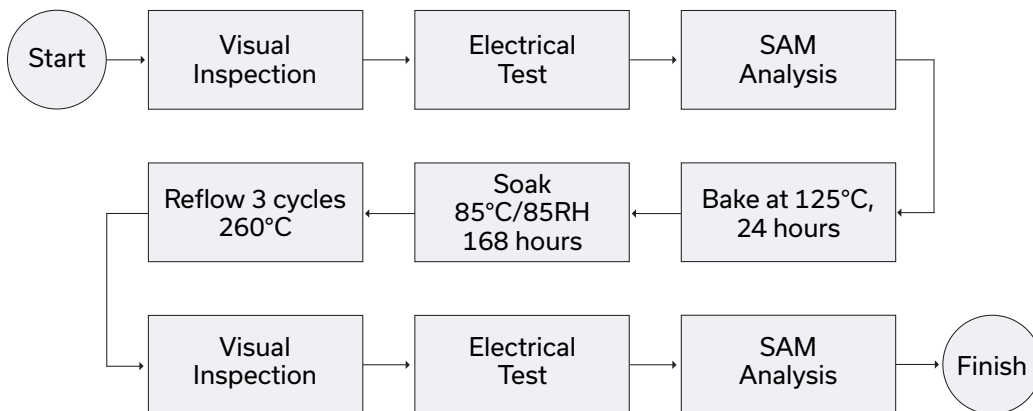

- NOTES**
- A. Performance and quality attributes and conditions not expressly stated in this specification document are intended to be excluded and do not form a part of this specification document.
  - B. Electrical specifications and performance data contained in this specification document are based on Mini-Circuit's applicable established test performance criteria and measurement instructions.
  - C. The parts covered by this specification document are subject to Mini-Circuits standard limited warranty and terms and conditions (collectively, "Standard Terms"); Purchasers of this part are entitled to the rights and benefits contained therein. For a full statement of the standard. Terms and the exclusive rights and remedies thereunder, please visit Mini-Circuits' website at [www.minicircuits.com/MCLStore/terms.jsp](http://www.minicircuits.com/MCLStore/terms.jsp)

## Looking for pricing, stock, or lifecycle information?

Click below to explore more details on WIN SOURCE:

 [View PGA-103+](#) on WIN SOURCE

 [Mini-Circuits](#) Information

## Optimize Your Supply Chain with WIN SOURCE Solutions

-  Global Sourcing Solution
-  Obsolete Management
-  Cost Control Management
-  Shortage Management
-  Alternative Solution
-  Excess Inventory Management