



**THE DATASHEET OF
PESD5V0S2UQ**



Important notice

Dear Customer,

On 7 February 2017 the former NXP Standard Product business became a new company with the tradename **Nexperia**. Nexperia is an industry leading supplier of Discrete, Logic and PowerMOS semiconductors with its focus on the automotive, industrial, computing, consumer and wearable application markets

In data sheets and application notes which still contain NXP or Philips Semiconductors references, use the references to Nexperia, as shown below.

Instead of <http://www.nxp.com>, <http://www.philips.com/> or <http://www.semiconductors.philips.com/>, use <http://www.nexperia.com>

Instead of sales.addresses@www.nxp.com or sales.addresses@www.semiconductors.philips.com, use salesaddresses@nexperia.com (email)

Replace the copyright notice at the bottom of each page or elsewhere in the document, depending on the version, as shown below:

- © NXP N.V. (year). All rights reserved or © Koninklijke Philips Electronics N.V. (year). All rights reserved

Should be replaced with:

- © **Nexperia B.V. (year). All rights reserved.**

If you have any questions related to the data sheet, please contact our nearest sales office via e-mail or telephone (details via salesaddresses@nexperia.com). Thank you for your cooperation and understanding,

Kind regards,

Team Nexperia

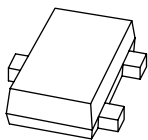

PESDxS2UQ series

Double ESD protection diodes in SOT663 package

Rev. 04 — 26 January 2010

Product data sheet

1. Product profile

1.1 General description

Unidirectional double ElectroStatic Discharge (ESD) protection diodes in a SOT663 ultra small and flat lead Surface-Mounted Device (SMD) plastic package designed to protect up to two signal lines from the damage caused by ESD and other transients.

1.2 Features

- Unidirectional ESD protection of up to two lines
- Max. peak pulse power: $P_{PP} = 150\text{ W}$ at $t_p = 8/20\ \mu\text{s}$
- Low clamping voltage: $V_{CL} = 20\text{ V}$ at $I_{PP} = 15\text{ A}$
- Low reverse leakage current: $I_{RM} < 1\text{ nA}$
- ESD protection up to 30 kV
- IEC 61000-4-2; level 4 (ESD)
- IEC 61000-4-5 (surge); $I_{PP} = 15\text{ A}$ at $t_p = 8/20\ \mu\text{s}$

1.3 Applications

- Computers and peripherals
- Audio and video equipment
- Communication systems
- High-speed data lines
- Parallel ports

1.4 Quick reference data

Table 1. Quick reference data

Symbol	Parameter	Conditions	Min	Typ	Max	Unit
V_{RWM}	reverse standoff voltage					
	PESD3V3S2UQ		-	-	3.3	V
	PESD5V0S2UQ		-	-	5	V
	PESD12VS2UQ		-	-	12	V
	PESD15VS2UQ		-	-	15	V
	PESD24VS2UQ		-	-	24	V
C_d	diode capacitance	$f = 1\text{ MHz}; V_R = 0\text{ V}$				
	PESD3V3S2UQ		-	200	275	pF
	PESD5V0S2UQ		-	150	215	pF
	PESD12VS2UQ		-	38	100	pF
	PESD15VS2UQ		-	32	70	pF
	PESD24VS2UQ		-	23	50	pF

2. Pinning information

Table 2. Pinning

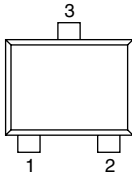
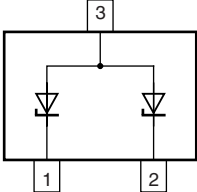
Pin	Description	Simplified outline	Graphic symbol
1	cathode 1		
2	cathode 2		
3	common anode		

006aaa154

3. Ordering information

Table 3. Ordering information

Type number	Package		
	Name	Description	Version
PESD3V3S2UQ	-	plastic surface-mounted package; 3 leads	SOT663
PESD5V0S2UQ			
PESD12VS2UQ			
PESD15VS2UQ			
PESD24VS2UQ			

4. Marking

Table 4. Marking codes

Type number	Marking code
PESD3V3S2UQ	E1
PESD5V0S2UQ	E2
PESD12VS2UQ	E3
PESD15VS2UQ	E4
PESD24VS2UQ	E5

5. Limiting values

Table 5. Limiting values

In accordance with the Absolute Maximum Rating System (IEC 60134).

Symbol	Parameter	Conditions	Min	Max	Unit
Per diode					
P _{PP}	peak pulse power	t _p = 8/20 μs	[1][2] -	150	W
I _{PP}	peak pulse current	t _p = 8/20 μs	[1][2]		
	PESD3V3S2UQ		-	15	A
	PESD5V0S2UQ		-	15	A
	PESD12VS2UQ		-	5	A
	PESD15VS2UQ		-	5	A
	PESD24VS2UQ		-	3	A
Per device					
T _j	junction temperature		-	150	°C
T _{amb}	ambient temperature		-65	+150	°C
T _{stg}	storage temperature		-65	+150	°C

[1] Non-repetitive current pulse 8/20 μs exponential decay waveform according to IEC 61000-4-5.

[2] Measured across either pins 1 and 3 or pins 2 and 3.

Table 6. ESD maximum ratings

T_{amb} = 25 °C unless otherwise specified.

Symbol	Parameter	Conditions	Min	Max	Unit
Per diode					
V _{ESD}	electrostatic discharge voltage	IEC 61000-4-2 (contact discharge)	[1][2]		
	PESD3V3S2UQ		-	30	kV
	PESD5V0S2UQ		-	30	kV
	PESD12VS2UQ		-	30	kV
	PESD15VS2UQ		-	30	kV
	PESD24VS2UQ		-	23	kV
	PESDxS2UQ series	MIL-STD-883 (human body model)	-	10	kV

[1] Device stressed with ten non-repetitive ESD pulses.

[2] Measured across either pins 1 and 3 or pins 2 and 3.

Table 7. ESD standards compliance

Standard	Conditions
Per diode	
IEC 61000-4-2; level 4 (ESD)	> 15 kV (air); > 8 kV (contact)
MIL-STD-883; class 3 (human body model)	> 4 kV

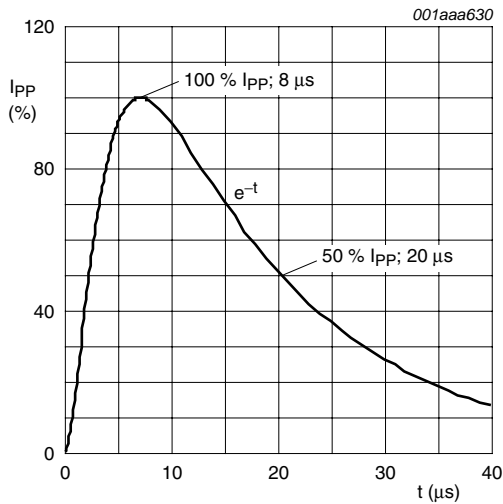

Fig 1. 8/20 μs pulse waveform according to IEC 61000-4-5

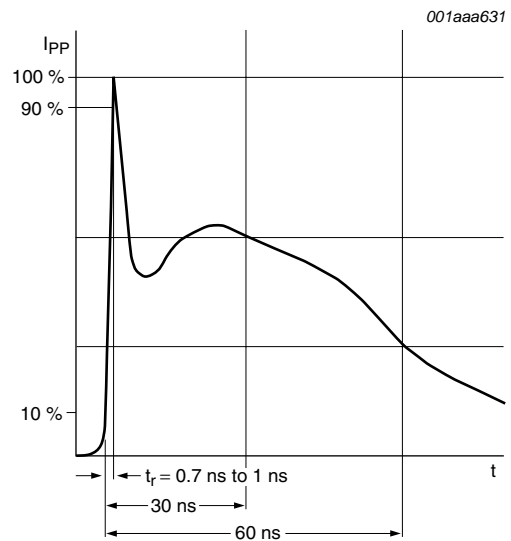

Fig 2. ESD pulse waveform according to IEC 61000-4-2

6. Characteristics

Table 8. Characteristics

$T_j = 25\text{ }^\circ\text{C}$ unless otherwise specified.

Symbol	Parameter	Conditions	Min	Typ	Max	Unit
Per diode						
V_{RWM}	reverse standoff voltage					
	PESD3V3S2UQ		-	-	3.3	V
	PESD5V0S2UQ		-	-	5	V
	PESD12VS2UQ		-	-	12	V
	PESD15VS2UQ		-	-	15	V
	PESD24VS2UQ		-	-	24	V
I_{RM}	reverse leakage current					
	PESD3V3S2UQ	$V_{RWM} = 3.3\text{ V}$	-	0.55	3	μA
	PESD5V0S2UQ	$V_{RWM} = 5\text{ V}$	-	50	300	nA
	PESD12VS2UQ	$V_{RWM} = 12\text{ V}$	-	<1	30	nA
	PESD15VS2UQ	$V_{RWM} = 15\text{ V}$	-	<1	50	nA
	PESD24VS2UQ	$V_{RWM} = 24\text{ V}$	-	<1	50	nA
V_{BR}	breakdown voltage	$I_R = 5\text{ mA}$				
	PESD3V3S2UQ		5.2	5.6	6.0	V
	PESD5V0S2UQ		6.4	6.8	7.2	V
	PESD12VS2UQ		14.7	15.0	15.3	V
	PESD15VS2UQ		17.6	18.0	18.4	V
	PESD24VS2UQ		26.5	27.0	27.5	V

Table 8. Characteristics ...continued $T_j = 25\text{ }^\circ\text{C}$ unless otherwise specified.

Symbol	Parameter	Conditions	Min	Typ	Max	Unit
C_d	diode capacitance	$f = 1\text{ MHz}; V_R = 0\text{ V}$				
	PESD3V3S2UQ		-	200	275	pF
	PESD5V0S2UQ		-	150	215	pF
	PESD12VS2UQ		-	38	100	pF
	PESD15VS2UQ		-	32	70	pF
	PESD24VS2UQ		-	23	50	pF
V_{CL}	clamping voltage		[1][2]			
	PESD3V3S2UQ	$I_{PP} = 1\text{ A}$	-	-	8	V
		$I_{PP} = 15\text{ A}$	-	-	20	V
	PESD5V0S2UQ	$I_{PP} = 1\text{ A}$	-	-	9	V
		$I_{PP} = 15\text{ A}$	-	-	20	V
	PESD12VS2UQ	$I_{PP} = 1\text{ A}$	-	-	19	V
		$I_{PP} = 5\text{ A}$	-	-	35	V
	PESD15VS2UQ	$I_{PP} = 1\text{ A}$	-	-	23	V
		$I_{PP} = 5\text{ A}$	-	-	40	V
	PESD24VS2UQ	$I_{PP} = 1\text{ A}$	-	-	36	V
		$I_{PP} = 3\text{ A}$	-	-	70	V
	r_{dif}	differential resistance				
PESD3V3S2UQ		$I_R = 5\text{ mA}$	-	-	40	Ω
PESD5V0S2UQ		$I_R = 5\text{ mA}$	-	-	15	Ω
PESD12VS2UQ		$I_R = 5\text{ mA}$	-	-	15	Ω
PESD15VS2UQ		$I_R = 1\text{ mA}$	-	-	225	Ω
PESD24VS2UQ		$I_R = 0.5\text{ mA}$	-	-	300	Ω

[1] Non-repetitive current pulse 8/20 μs exponential decay waveform according to IEC 61000-4-5.

[2] Measured across either pins 1 and 3 or pins 2 and 3.

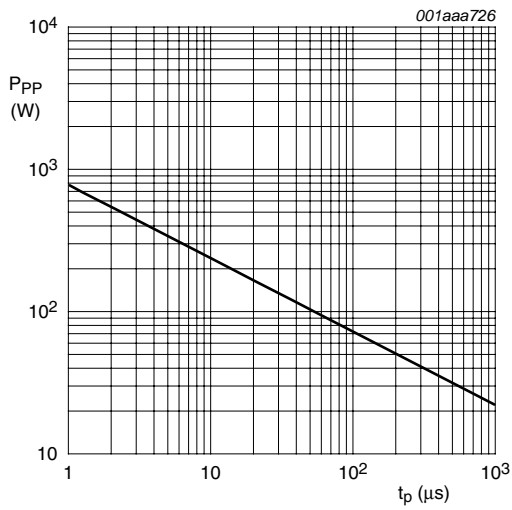

Fig 3. Peak pulse power dissipation as a function of pulse duration; typical values

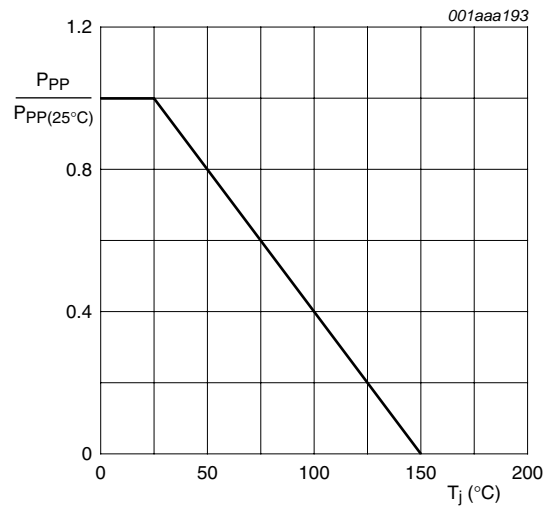
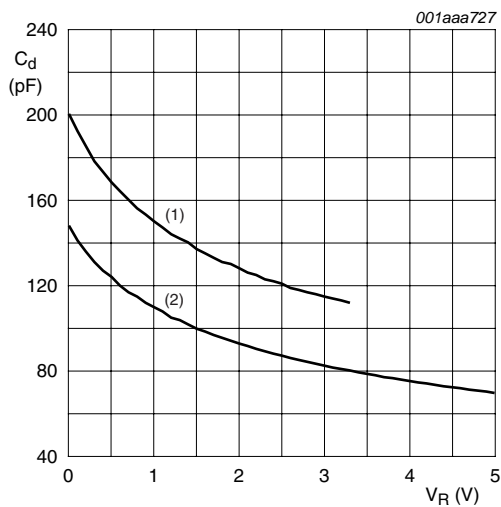
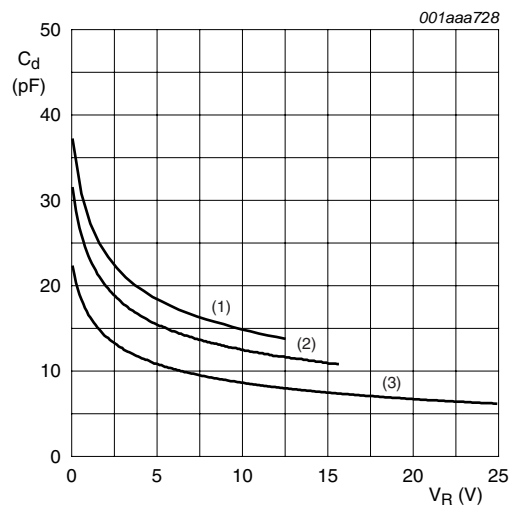

Fig 4. Relative variation of peak pulse power as a function of junction temperature; typical values



$f = 1\text{ MHz}$; $T_{amb} = 25\text{ }^{\circ}\text{C}$
 (1) PESD3V3S2UQ; $V_{RWM} = 3.3\text{ V}$
 (2) PESD5V0S2UQ; $V_{RWM} = 5\text{ V}$

Fig 5. Diode capacitance as a function of reverse voltage; typical values



$f = 1\text{ MHz}$; $T_{amb} = 25\text{ }^{\circ}\text{C}$
 (1) PESD12VS2UQ; $V_{RWM} = 12\text{ V}$
 (2) PESD15VS2UQ; $V_{RWM} = 15\text{ V}$
 (3) PESD24VS2UQ; $V_{RWM} = 24\text{ V}$

Fig 6. Diode capacitance as a function of reverse voltage; typical values

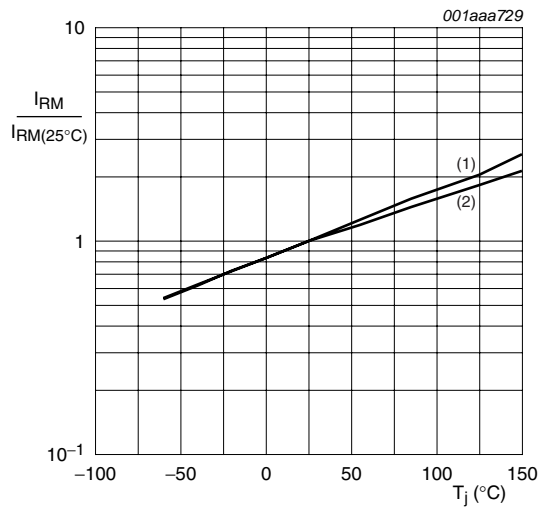

- (1) PESD3V3S2UQ; $V_{RWM} = 3.3$ V
 - (2) PESD5V0S2UQ; $V_{RWM} = 5$ V
- I_R is less than 15 nA at 150 °C for:
- PESD12VS2UQ; $V_{RWM} = 12$ V
 - PESD15VS2UQ; $V_{RWM} = 15$ V
 - PESD24VS2UQ; $V_{RWM} = 24$ V

Fig 7. Relative variation of reverse leakage current as a function of junction temperature; typical values

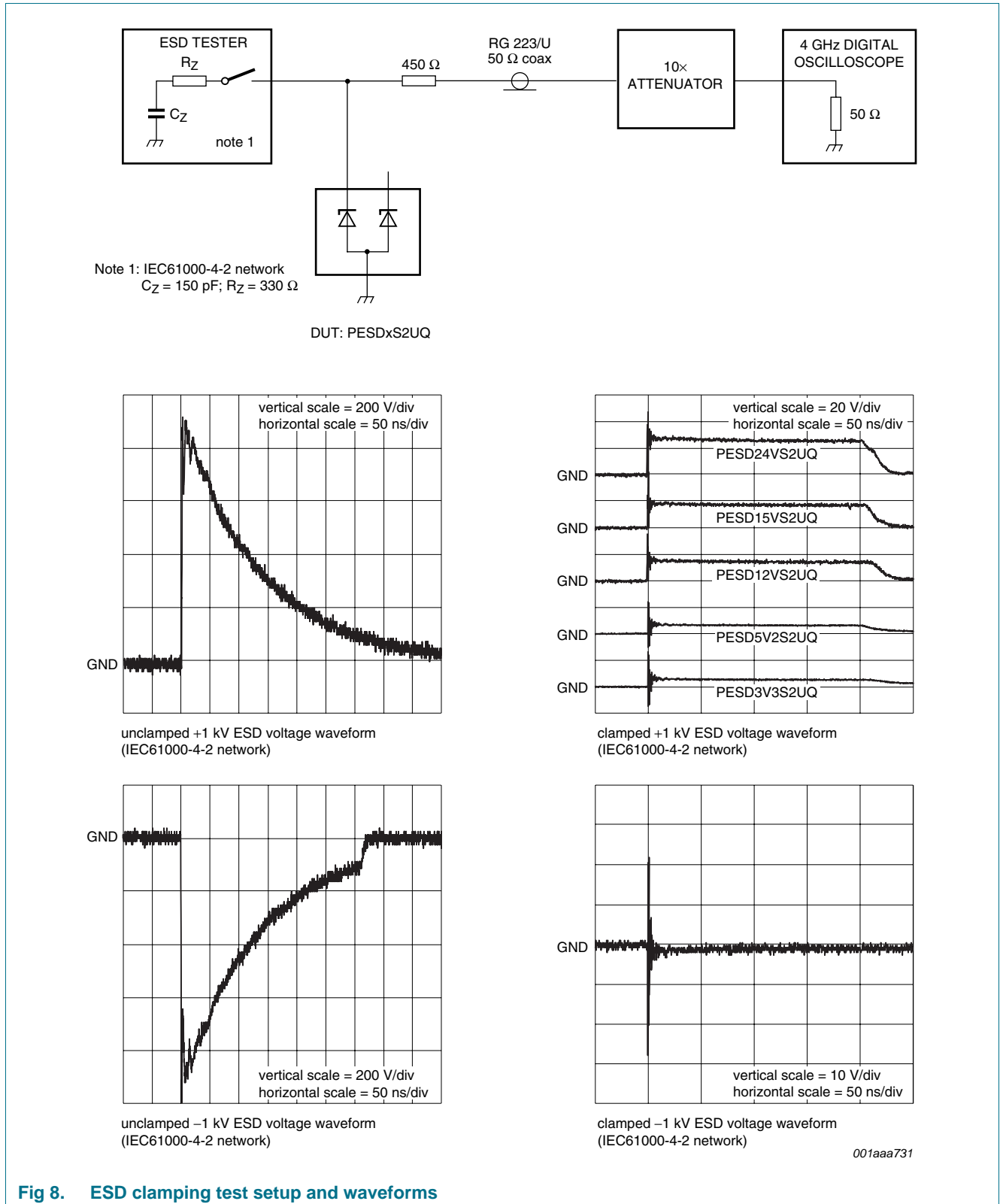

Fig 8. ESD clamping test setup and waveforms

7. Application information

The PESDxS2UQ series is designed for the protection of up to two unidirectional data lines from the damage caused by ESD and surge pulses. The devices may be used on lines where the signal polarities are below ground. The PESDxS2UQ series provides a surge capability of up to 150 W (P_{PP}) per line for an 8/20 μ s waveform.

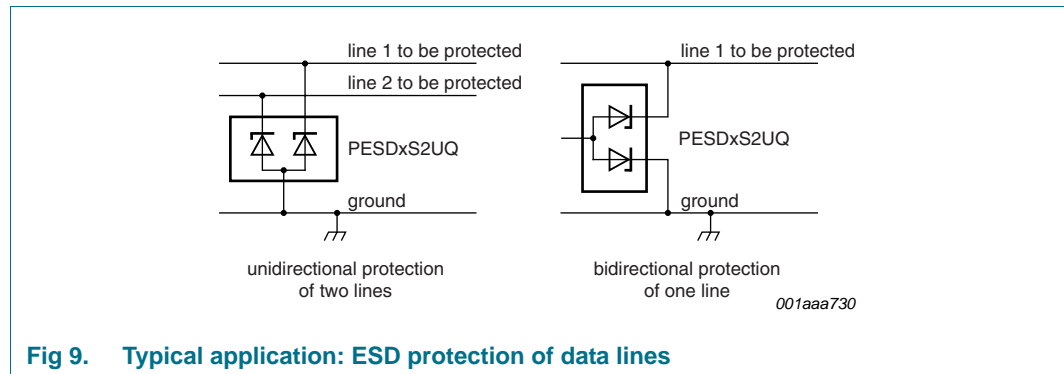

Fig 9. Typical application: ESD protection of data lines

Circuit board layout and protection device placement

Circuit board layout is critical for the suppression of ESD, Electrical Fast Transient (EFT) and surge transients. The following guidelines are recommended:

1. Place the device as close to the input terminal or connector as possible.
2. The path length between the device and the protected line should be minimized.
3. Keep parallel signal paths to a minimum.
4. Avoid running protected conductors in parallel with unprotected conductors.
5. Minimize all Printed-Circuit Board (PCB) conductive loops including power and ground loops.
6. Minimize the length of the transient return path to ground.
7. Avoid using shared transient return paths to a common ground point.
8. Ground planes should be used whenever possible. For multilayer PCBs, use ground vias.

8. Package outline

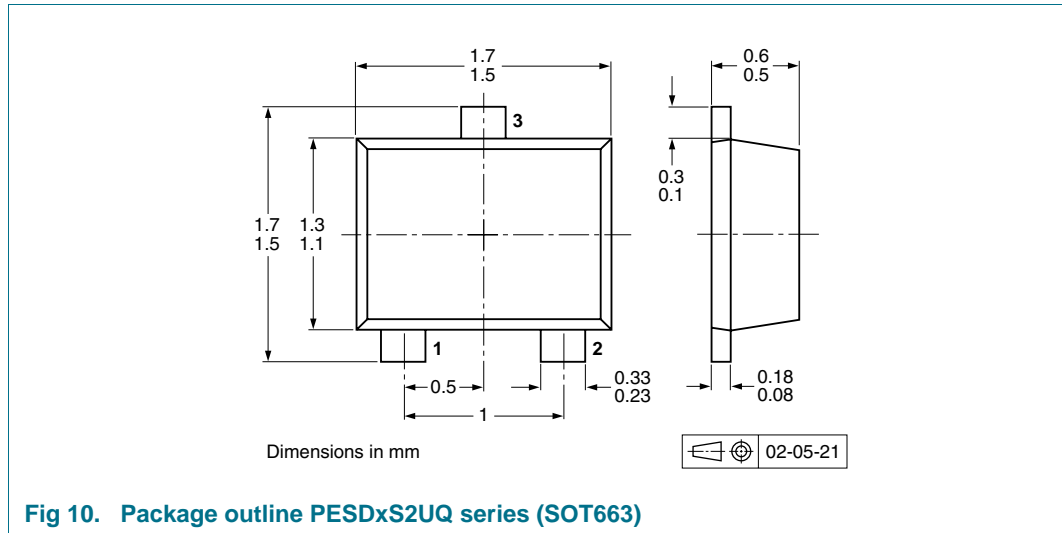

9. Packing information

Table 9. Packing methods

The indicated -xxx are the last three digits of the 12NC ordering code.^[1]

Type number	Package	Description	Packing quantity	
			4000	8000
PESD3V3S2UQ	SOT663	2 mm pitch, 8 mm tape and reel	-	-315
PESD5V0S2UQ				
PESD12VS2UQ				
PESD15VS2UQ				
PESD24VS2UQ				
PESD3V3S2UQ	SOT663	4 mm pitch, 8 mm tape and reel	-115	-
PESD5V0S2UQ				
PESD12VS2UQ				
PESD15VS2UQ				
PESD24VS2UQ				

[1] For further information and the availability of packing methods, see [Section 12](#).

10. Revision history

Table 10. Revision history

Document ID	Release date	Data sheet status	Change notice	Supersedes
PESDXS2UQ_SER_4	20100126	Product data sheet	-	PESDXS2UQ_SER_N_3
Modifications:	<ul style="list-style-type: none"> • The format of this data sheet has been redesigned to comply with the new identity guidelines of NXP Semiconductors. • Legal texts have been adapted to the new company name where appropriate. • Section 1.1 “General description”: amended • Section 1.4 “Quick reference data”: amended • Table 2 “Pinning”: updated • Section 7 “Application information”: amended • Figure 10: superseded by minimized package outline drawing • Section 9 “Packing information”: added • Section 11 “Legal information”: updated 			
PESDXS2UQ_SER_N_3	20080911	Product data sheet	-	PESDXS2UQ_SERIES_2
PESDXS2UQ_SERIES_2	20040427	Product specification	-	PESDXS2UQ_SERIES_1
PESDXS2UQ_SERIES_1	20031215	Product specification	-	-

11. Legal information

11.1 Data sheet status

Document status ^{[1][2]}	Product status ^[3]	Definition
Objective [short] data sheet	Development	This document contains data from the objective specification for product development.
Preliminary [short] data sheet	Qualification	This document contains data from the preliminary specification.
Product [short] data sheet	Production	This document contains the product specification.

[1] Please consult the most recently issued document before initiating or completing a design.

[2] The term 'short data sheet' is explained in section "Definitions".

[3] The product status of device(s) described in this document may have changed since this document was published and may differ in case of multiple devices. The latest product status information is available on the Internet at URL <http://www.nxp.com>.

11.2 Definitions

Draft — The document is a draft version only. The content is still under internal review and subject to formal approval, which may result in modifications or additions. NXP Semiconductors does not give any representations or warranties as to the accuracy or completeness of information included herein and shall have no liability for the consequences of use of such information.

Short data sheet — A short data sheet is an extract from a full data sheet with the same product type number(s) and title. A short data sheet is intended for quick reference only and should not be relied upon to contain detailed and full information. For detailed and full information see the relevant full data sheet, which is available on request via the local NXP Semiconductors sales office. In case of any inconsistency or conflict with the short data sheet, the full data sheet shall prevail.

11.3 Disclaimers

General — Information in this document is believed to be accurate and reliable. However, NXP Semiconductors does not give any representations or warranties, expressed or implied, as to the accuracy or completeness of such information and shall have no liability for the consequences of use of such information.

Right to make changes — NXP Semiconductors reserves the right to make changes to information published in this document, including without limitation specifications and product descriptions, at any time and without notice. This document supersedes and replaces all information supplied prior to the publication hereof.

Suitability for use — NXP Semiconductors products are not designed, authorized or warranted to be suitable for use in medical, military, aircraft, space or life support equipment, nor in applications where failure or malfunction of an NXP Semiconductors product can reasonably be expected to result in personal injury, death or severe property or environmental

damage. NXP Semiconductors accepts no liability for inclusion and/or use of NXP Semiconductors products in such equipment or applications and therefore such inclusion and/or use is at the customer's own risk.

Applications — Applications that are described herein for any of these products are for illustrative purposes only. NXP Semiconductors makes no representation or warranty that such applications will be suitable for the specified use without further testing or modification.

Limiting values — Stress above one or more limiting values (as defined in the Absolute Maximum Ratings System of IEC 60134) may cause permanent damage to the device. Limiting values are stress ratings only and operation of the device at these or any other conditions above those given in the Characteristics sections of this document is not implied. Exposure to limiting values for extended periods may affect device reliability.

Terms and conditions of sale — NXP Semiconductors products are sold subject to the general terms and conditions of commercial sale, as published at <http://www.nxp.com/profile/terms>, including those pertaining to warranty, intellectual property rights infringement and limitation of liability, unless explicitly otherwise agreed to in writing by NXP Semiconductors. In case of any inconsistency or conflict between information in this document and such terms and conditions, the latter will prevail.

No offer to sell or license — Nothing in this document may be interpreted or construed as an offer to sell products that is open for acceptance or the grant, conveyance or implication of any license under any copyrights, patents or other industrial or intellectual property rights.

Export control — This document as well as the item(s) described herein may be subject to export control regulations. Export might require a prior authorization from national authorities.

Quick reference data — The Quick reference data is an extract of the product data given in the Limiting values and Characteristics sections of this document, and as such is not complete, exhaustive or legally binding.

11.4 Trademarks

Notice: All referenced brands, product names, service names and trademarks are the property of their respective owners.

12. Contact information

For more information, please visit: <http://www.nxp.com>

For sales office addresses, please send an email to: salesaddresses@nxp.com

13. Contents

1	Product profile	1
1.1	General description	1
1.2	Features	1
1.3	Applications	1
1.4	Quick reference data	1
2	Pinning information	2
3	Ordering information	2
4	Marking	2
5	Limiting values	3
6	Characteristics	4
7	Application information	9
8	Package outline	10
9	Packing information	10
10	Revision history	11
11	Legal information	12
11.1	Data sheet status	12
11.2	Definitions	12
11.3	Disclaimers	12
11.4	Trademarks	12
12	Contact information	12
13	Contents	13

Please be aware that important notices concerning this document and the product(s) described herein, have been included in section 'Legal information'.



© NXP B.V. 2010.

All rights reserved.

For more information, please visit: <http://www.nxp.com>



For sales office addresses, please send an email to: salesaddresses@nxp.com

Date of release: 26 January 2010

Document identifier: PESDxS2UQ_SER_4

Looking for pricing, stock, or lifecycle information?

Click below to explore more details on WIN SOURCE:

-  [View PESD5V0S2UQ on WIN SOURCE](#)
-  [NXP / Nexperia Information](#)

Optimize Your Supply Chain with WIN SOURCE Solutions

-  Global Sourcing Solution
-  Obsolete Management
-  Cost Control Management
-  Shortage Management
-  Alternative Solution
-  Excess Inventory Management