



THE DATASHEET OF PESD15VS2UT



Important notice

Dear Customer,

On 7 February 2017 the former NXP Standard Product business became a new company with the tradename **Nexperia**. Nexperia is an industry leading supplier of Discrete, Logic and PowerMOS semiconductors with its focus on the automotive, industrial, computing, consumer and wearable application markets

In data sheets and application notes which still contain NXP or Philips Semiconductors references, use the references to Nexperia, as shown below.

Instead of <http://www.nxp.com>, <http://www.philips.com/> or <http://www.semiconductors.philips.com/>, use <http://www.nexperia.com>

Instead of sales.addresses@www.nxp.com or sales.addresses@www.semiconductors.philips.com, use salesaddresses@nexperia.com (email)

Replace the copyright notice at the bottom of each page or elsewhere in the document, depending on the version, as shown below:

- © NXP N.V. (year). All rights reserved or © Koninklijke Philips Electronics N.V. (year). All rights reserved

Should be replaced with:

- © **Nexperia B.V. (year). All rights reserved.**

If you have any questions related to the data sheet, please contact our nearest sales office via e-mail or telephone (details via salesaddresses@nexperia.com). Thank you for your cooperation and understanding,

Kind regards,

Team Nexperia

DATA SHEET



PESDxS2UT series

Double ESD protection diodes in
SOT23 package

Product data sheet
Supersedes data of 2003 Aug 20

2004 Apr 15

Double ESD protection diodes in SOT23 package

PESDxS2UT series

FEATURES

- Uni-directional ESD protection of up to two lines
- Max. peak pulse power: $P_{pp} = 330 \text{ W}$ at $t_p = 8/20 \mu\text{s}$
- Low clamping voltage: $V_{(CL)R} = 20 \text{ V}$ at $I_{pp} = 18 \text{ A}$
- Ultra-low reverse leakage current: $I_{RM} < 700 \text{ nA}$
- ESD protection $> 23 \text{ kV}$
- IEC 61000-4-2; level 4 (ESD)
- IEC 61000-4-5 (surge); $I_{pp} = 18 \text{ A}$ at $t_p = 8/20 \mu\text{s}$.

APPLICATIONS

- Computers and peripherals
- Communication systems
- Audio and video equipment
- High speed data lines
- Parallel ports.

DESCRIPTION

Uni-directional double ESD protection diodes in a SOT23 plastic package. Designed to protect up to two transmission or data lines from ElectroStatic Discharge (ESD) damage.

MARKING

TYPE NUMBER	MARKING CODE ⁽¹⁾
PESD3V3S2UT	*U9
PESD5V2S2UT	*U1
PESD12VS2UT	*U2
PESD15VS2UT	*U3
PESD24VS2UT	*U4

Note

1. * = p : made in Hong Kong.
 * = t : made in Malaysia.
 * = W : made in China.

QUICK REFERENCE DATA

SYMBOL	PARAMETER	VALUE	UNIT
V_{RWM}	reverse stand-off voltage	3.3, 5.2, 12, 15 and 24	V
C_d	diode capacitance $V_R = 0 \text{ V};$ $f = 1 \text{ MHz}$	207, 152, 38, 32 and 23	pF
	number of protected lines	2	

PINNING

PIN	DESCRIPTION
1	cathode 1
2	cathode 2
3	common anode

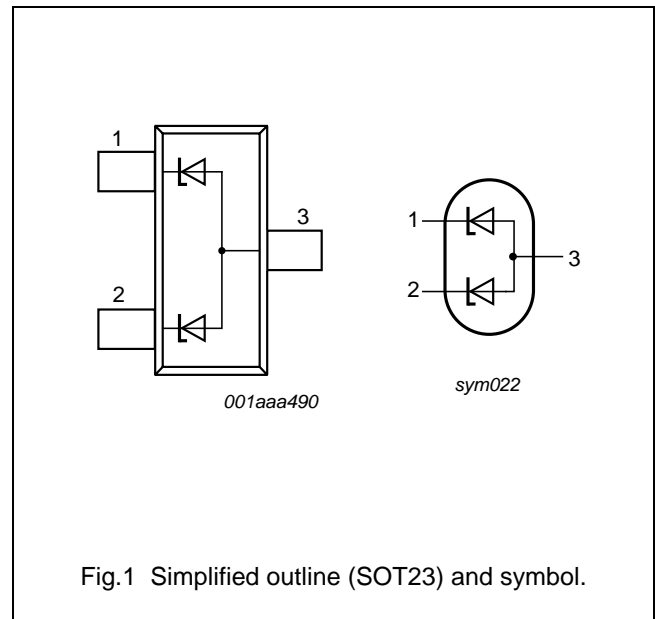

Double ESD protection diodes in SOT23 package

PESDxS2UT series

ORDERING INFORMATION

TYPE NUMBER	PACKAGE		
	NAME	DESCRIPTION	VERSION
PESD3V3S2UT	-	plastic surface mounted package; 3 leads	SOT23
PESD5V2S2UT			
PESD12VS2UT			
PESD15VS2UT			
PESD24VS2UT			

LIMITING VALUES

In accordance with the Absolute Maximum Rating System (IEC 60134).

SYMBOL	PARAMETER	CONDITIONS	MIN.	MAX.	UNIT
P _{pp}	peak pulse power	8/20 μs pulse; notes 1 and 2	-	330	W
	PESD3V3S2UT				
	PESD5V2S2UT				
	PESD12VS2UT				
	PESD15VS2UT				
PESD24VS2UT	160	W			
I _{pp}	peak pulse current	8/20 μs pulse; notes 1 and 2	-	18	A
	PESD3V3S2UT				
	PESD5V2S2UT				
	PESD12VS2UT				
	PESD15VS2UT				
PESD24VS2UT	3	A			
T _j	junction temperature		-	150	°C
T _{amb}	operating ambient temperature		-65	+150	°C
T _{stg}	storage temperature		-65	+150	°C

Notes

1. Non-repetitive current pulse 8/20μ μs exponential decay waveform; see Fig.2.
2. Measured across either pins 1 and 3 or pins 2 and 3.

Double ESD protection diodes in SOT23 package

PESDxS2UT series

ESD maximum ratings

SYMBOL	PARAMETER	CONDITIONS	VALUE	UNIT
ESD	electrostatic discharge capability	IEC 61000-4-2 (contact discharge); notes 1 and 2		
		PESD3V3S2UT	30	kV
		PESD5V2S2UT	30	kV
		PESD12VS2UT	30	kV
		PESD15VS2UT	30	kV
		PESD24VS2UT	23	kV
		HBM MIL-Std 883 PESDxS2UT series	10	kV

Notes

1. Device stressed with ten non-repetitive ElectroStatic Discharge (ESD) pulses; see Fig.3.
2. Measured across either pins 1 and 3 or pins 2 and 3.

ESD standards compliance

ESD STANDARD	CONDITIONS
IEC 61000-4-2; level 4 (ESD); see Fig.3	>15 kV (air); > 8 kV (contact)
HBM MIL-Std 883; class 3	>4 kV

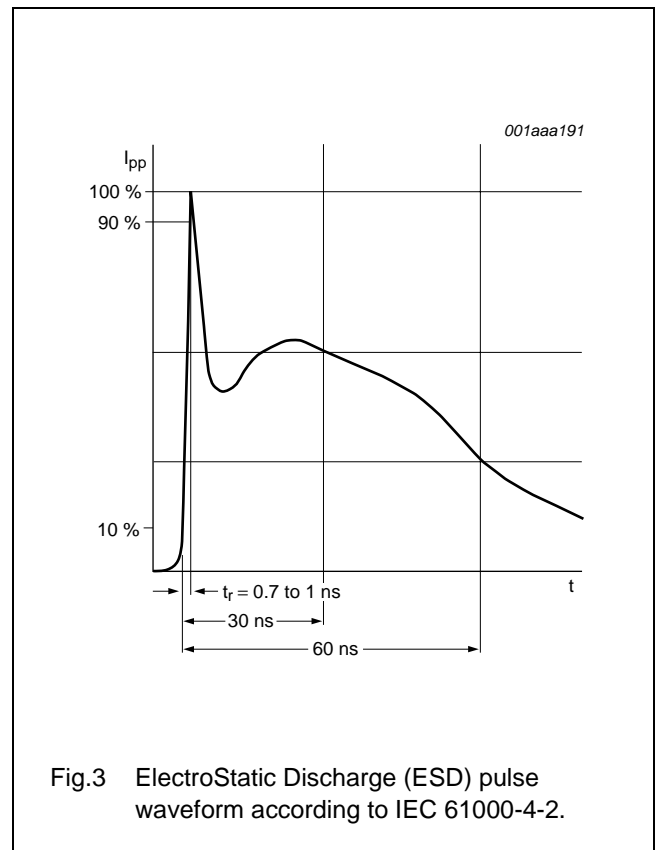
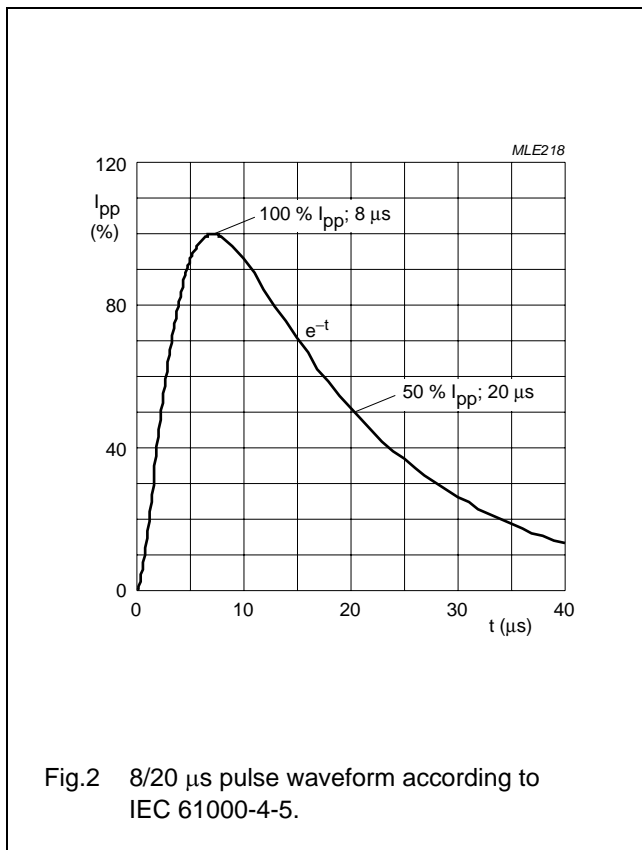

Double ESD protection diodes in SOT23 package

PESDxS2UT series

ELECTRICAL CHARACTERISTICS

$T_j = 25\text{ }^\circ\text{C}$ unless otherwise specified.

SYMBOL	PARAMETER	CONDITIONS	MIN.	TYP.	MAX.	UNIT
V_{RWM}	reverse stand-off voltage					
	PESD3V3S2UT		–	–	3.3	V
	PESD5V2S2UT		–	–	5.2	V
	PESD12VS2UT		–	–	12	V
	PESD15VS2UT		–	–	15	V
	PESD24VS2UT		–	–	24	V
I_{RM}	reverse leakage current					
	PESD3V3S2UT	$V_{RWM} = 3.3\text{ V}$	–	0.7	2	μA
	PESD5V2S2UT	$V_{RWM} = 5.2\text{ V}$	–	0.15	1	μA
	PESD12VS2UT	$V_{RWM} = 12\text{ V}$	–	<0.02	1	μA
	PESD15VS2UT	$V_{RWM} = 15\text{ V}$	–	<0.02	1	μA
	PESD24VS2UT	$V_{RWM} = 24\text{ V}$	–	<0.02	1	μA
V_{BR}	breakdown voltage	$I_Z = 5\text{ mA}$				
	PESD3V3S2UT		5.2	5.6	6.0	V
	PESD5V2S2UT		6.4	6.8	7.2	V
	PESD12VS2UT		14.7	15.0	15.3	V
	PESD15VS2UT		17.6	18.0	18.4	V
	PESD24VS2UT		26.5	27.0	27.5	V
C_d	diode capacitance	$f = 1\text{ MHz}; V_R = 0\text{ V}$				
	PESD3V3S2UT		–	207	300	pF
	PESD5V2S2UT		–	152	200	pF
	PESD12VS2UT		–	38	75	pF
	PESD15VS2UT		–	32	70	pF
	PESD24VS2UT		–	23	50	pF
$V_{(CL)R}$	clamping voltage	notes 1 and 2				
	PESD3V3S2UT	$I_{pp} = 1\text{ A}$	–	–	7	V
		$I_{pp} = 18\text{ A}$	–	–	20	V
	PESD5V2S2UT	$I_{pp} = 1\text{ A}$	–	–	9	V
		$I_{pp} = 15\text{ A}$	–	–	20	V
	PESD12VS2UT	$I_{pp} = 1\text{ A}$	–	–	19	V
		$I_{pp} = 5\text{ A}$	–	–	35	V
	PESD15VS2UT	$I_{pp} = 1\text{ A}$	–	–	23	V
		$I_{pp} = 5\text{ A}$	–	–	40	V
	PESD24VS2UT	$I_{pp} = 1\text{ A}$	–	–	36	V
$I_{pp} = 3\text{ A}$		–	–	70	V	

Double ESD protection diodes in SOT23 package

PESDxS2UT series

SYMBOL	PARAMETER	CONDITIONS	MIN.	TYP.	MAX.	UNIT
R _{diff}	differential resistance					
	PESD3V3S2UT	I _R = 1 mA	–	–	400	Ω
	PESD5V2S2UT	I _R = 1 mA	–	–	80	Ω
	PESD12VS2UT	I _R = 1 mA	–	–	200	Ω
	PESD15VS2UT	I _R = 1 mA	–	–	225	Ω
	PESD24VS2UT	I _R = 0.5 mA	–	–	300	Ω

Notes

1. Non-repetitive current pulse 8/20 μs exponential decay waveform; see Fig.2.
2. Measured either across pins 1 and 3 or pins 2 and 3.

GRAPHICAL DATA

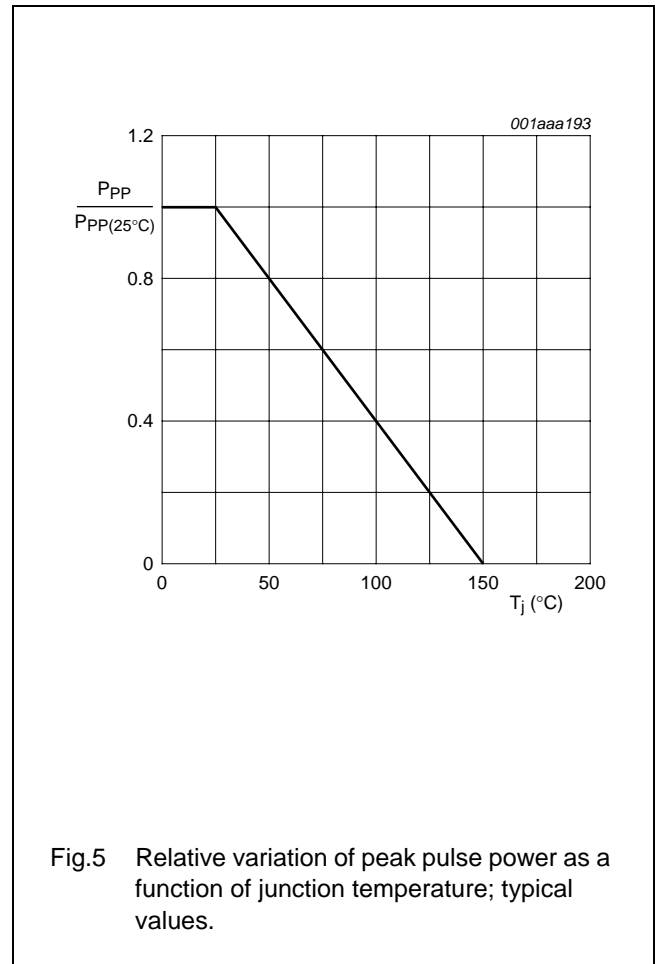
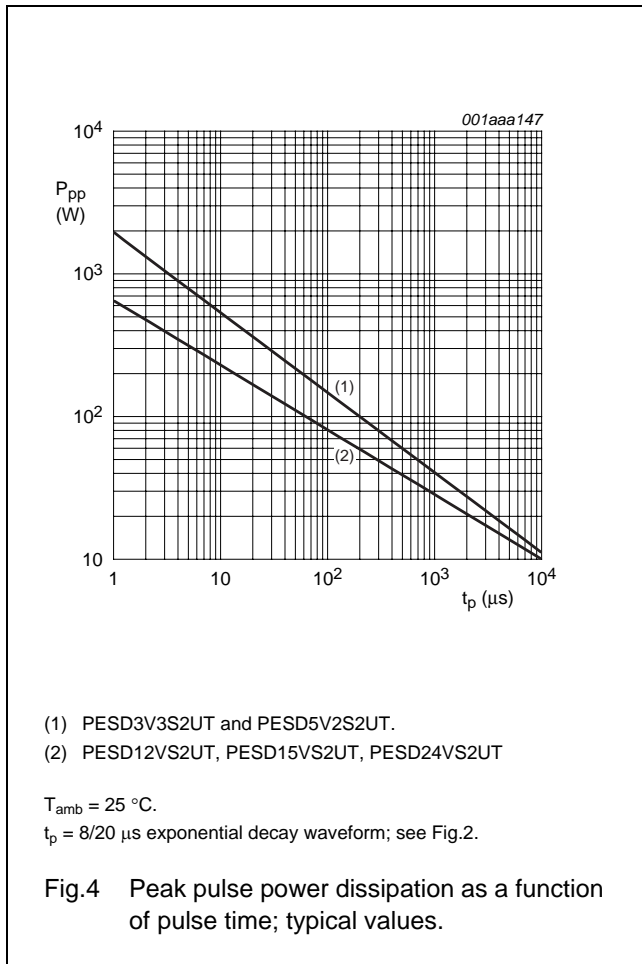

Double ESD protection diodes in SOT23 package

PESDxS2UT series

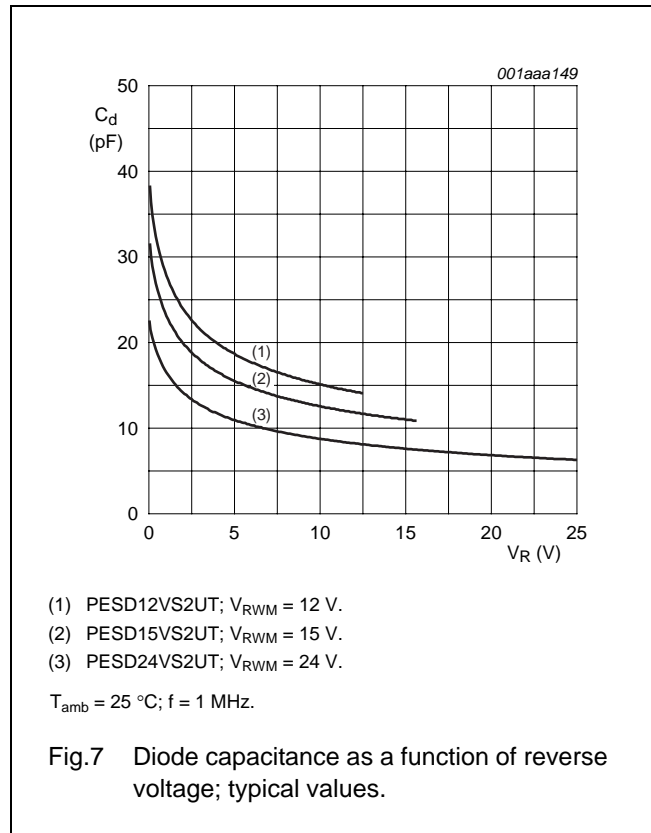
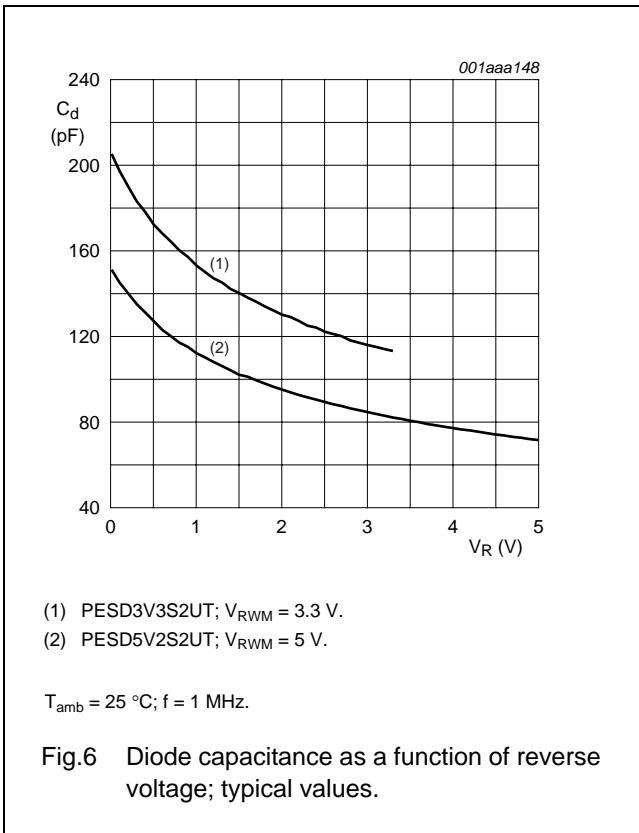

Double ESD protection diodes in SOT23 package

PESDxS2UT series

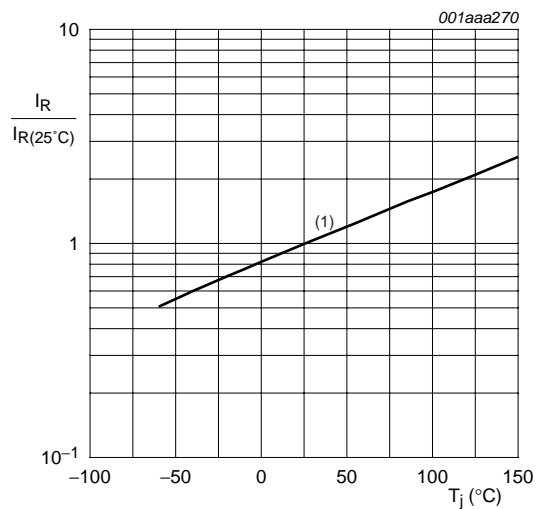

(1) PESD3V3S2UT; $V_{RWM} = 3.3$ V.
 PESD5V2S2UT; $V_{RWM} = 5$ V.

I_R is less than 10 nA at 150 °C for:
 PESD12V52UT; $V_{RWM} = 12$ V.
 PESD15VS2UT; $V_{RWM} = 15$ V.
 PESD24VS2UT; $V_{RWM} = 24$ V.

Fig.8 Relative variation of reverse leakage current as a function of junction temperature; typical values.

Double ESD protection diodes in SOT23 package

PESDxS2UT series

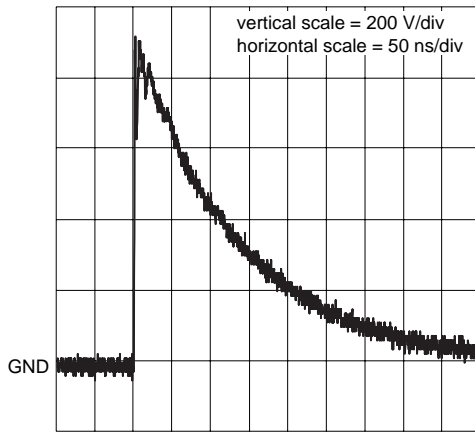
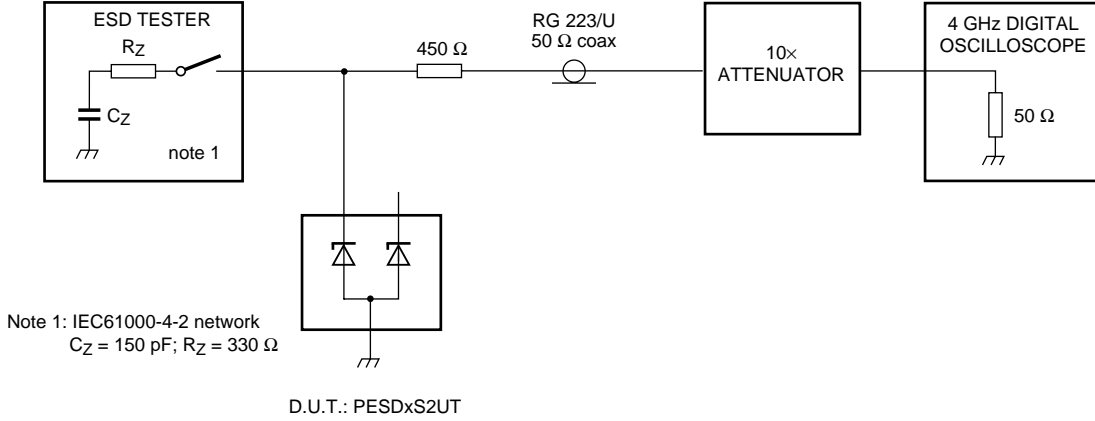

unclamped +1 kV ESD voltage waveform (IEC61000-4-2 network)

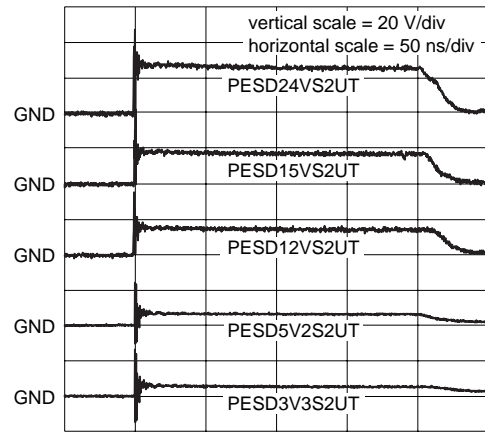

clamped +1 kV ESD voltage waveform (IEC61000-4-2 network)

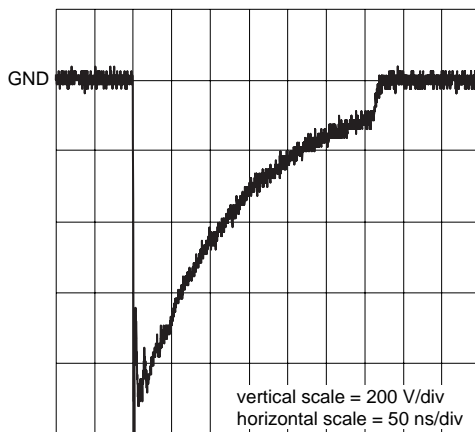

unclamped -1 kV ESD voltage waveform (IEC61000-4-2 network)

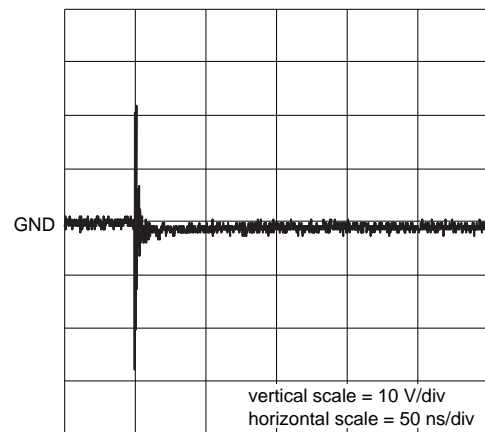

clamped -1 kV ESD voltage waveform (IEC61000-4-2 network)

001aaa492

Fig.9 ESD clamping test set-up and waveforms.

Double ESD protection diodes in SOT23 package

PESDxS2UT series

APPLICATION INFORMATION

The PESDxS2UT series is designed for uni-directional protection for up to two lines against damage caused by ElectroStatic Discharge (ESD) and surge pulses. The PESDxS2UT series may be used on lines where the signal polarities are below ground. PESDxS2UT series provide a surge capability of up to 330 W (P_{pp}) per line for an 8/20 μ s waveform.

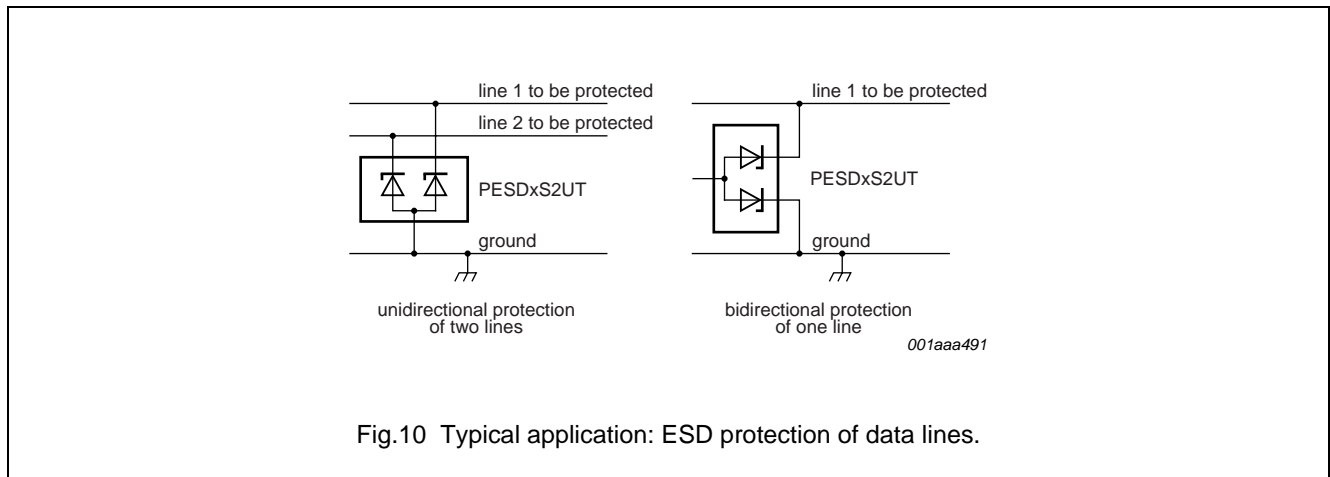

Circuit board layout and protection device placement

Circuit board layout is critical for the suppression of ESD, Electrical Fast Transient (EFT) and surge transients. The following guidelines are recommended:

- Place the PESDxS2UT as close as possible to the input terminal or connector.
- The path length between the PESDxS2UT and the protected line should be minimized.
- Keep parallel signal paths to a minimum.
- Avoid running protected conductors in parallel with unprotected conductors.
- Minimize all printed-circuit board conductive loops including power and ground loops.
- Minimize the length of transient return paths to ground.
- Avoid using shared return paths to a common ground point.
- Ground planes should be used whenever possible. For multilayer printed-circuit boards use ground vias.

Double ESD protection diodes in SOT23 package

PESDxS2UT series

PACKAGE OUTLINE

Plastic surface-mounted package; 3 leads

SOT23

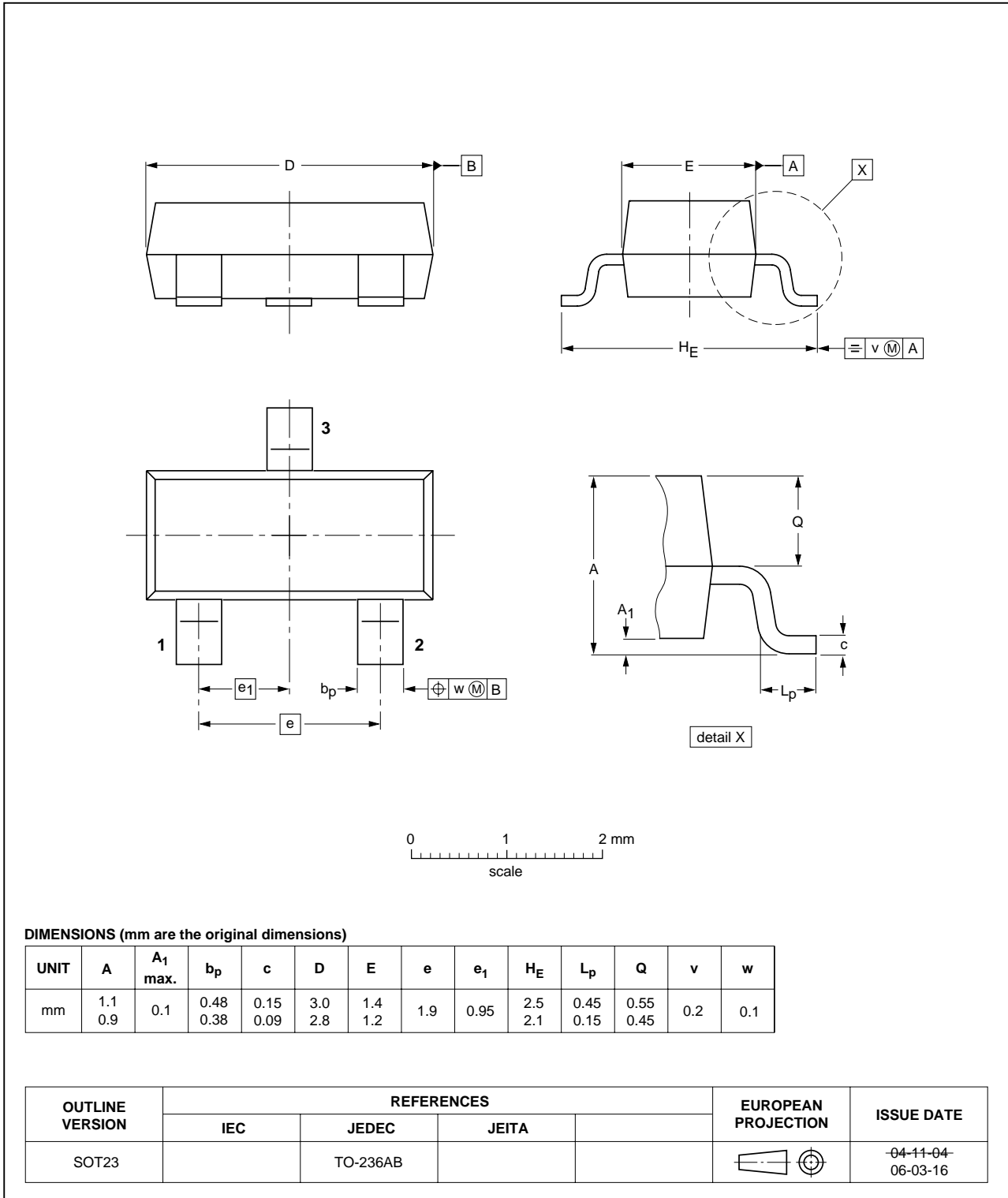

Double ESD protection diodes in SOT23 package

PESDxS2UT series

DATA SHEET STATUS

DOCUMENT STATUS ⁽¹⁾	PRODUCT STATUS ⁽²⁾	DEFINITION
Objective data sheet	Development	This document contains data from the objective specification for product development.
Preliminary data sheet	Qualification	This document contains data from the preliminary specification.
Product data sheet	Production	This document contains the product specification.

Notes

1. Please consult the most recently issued document before initiating or completing a design.
2. The product status of device(s) described in this document may have changed since this document was published and may differ in case of multiple devices. The latest product status information is available on the Internet at URL <http://www.nxp.com>.

DISCLAIMERS

General — Information in this document is believed to be accurate and reliable. However, NXP Semiconductors does not give any representations or warranties, expressed or implied, as to the accuracy or completeness of such information and shall have no liability for the consequences of use of such information.

Right to make changes — NXP Semiconductors reserves the right to make changes to information published in this document, including without limitation specifications and product descriptions, at any time and without notice. This document supersedes and replaces all information supplied prior to the publication hereof.

Suitability for use — NXP Semiconductors products are not designed, authorized or warranted to be suitable for use in medical, military, aircraft, space or life support equipment, nor in applications where failure or malfunction of an NXP Semiconductors product can reasonably be expected to result in personal injury, death or severe property or environmental damage. NXP Semiconductors accepts no liability for inclusion and/or use of NXP Semiconductors products in such equipment or applications and therefore such inclusion and/or use is at the customer's own risk.

Applications — Applications that are described herein for any of these products are for illustrative purposes only. NXP Semiconductors makes no representation or warranty that such applications will be suitable for the specified use without further testing or modification.

Limiting values — Stress above one or more limiting values (as defined in the Absolute Maximum Ratings System of IEC 60134) may cause permanent damage to the device. Limiting values are stress ratings only and operation of the device at these or any other conditions

above those given in the Characteristics sections of this document is not implied. Exposure to limiting values for extended periods may affect device reliability.

Terms and conditions of sale — NXP Semiconductors products are sold subject to the general terms and conditions of commercial sale, as published at <http://www.nxp.com/profile/terms>, including those pertaining to warranty, intellectual property rights infringement and limitation of liability, unless explicitly otherwise agreed to in writing by NXP Semiconductors. In case of any inconsistency or conflict between information in this document and such terms and conditions, the latter will prevail.

No offer to sell or license — Nothing in this document may be interpreted or construed as an offer to sell products that is open for acceptance or the grant, conveyance or implication of any license under any copyrights, patents or other industrial or intellectual property rights.

Export control — This document as well as the item(s) described herein may be subject to export control regulations. Export might require a prior authorization from national authorities.

Quick reference data — The Quick reference data is an extract of the product data given in the Limiting values and Characteristics sections of this document, and as such is not complete, exhaustive or legally binding.

NXP Semiconductors

Customer notification

This data sheet was changed to reflect the new company name NXP Semiconductors, including new legal definitions and disclaimers. No changes were made to the technical content, except for package outline drawings which were updated to the latest version.

Contact information

For additional information please visit: <http://www.nxp.com>

For sales offices addresses send e-mail to: salesaddresses@nxp.com

© NXP B.V. 2009

All rights are reserved. Reproduction in whole or in part is prohibited without the prior written consent of the copyright owner.

The information presented in this document does not form part of any quotation or contract, is believed to be accurate and reliable and may be changed without notice. No liability will be accepted by the publisher for any consequence of its use. Publication thereof does not convey nor imply any license under patent- or other industrial or intellectual property rights.

Printed in The Netherlands

R76/03/pp13

Date of release: 2004 Apr 15



Document order number: 9397 750 12823

founded by

PHILIPS

Looking for pricing, stock, or lifecycle information?

Click below to explore more details on WIN SOURCE:

-  [View PESD15VS2UT on WIN SOURCE](#)
-  [NXP / Nexperia Information](#)

Optimize Your Supply Chain with WIN SOURCE Solutions

-  Global Sourcing Solution
-  Obsolete Management
-  Cost Control Management
-  Shortage Management
-  Alternative Solution
-  Excess Inventory Management