



**THE DATASHEET OF
PEB3086FV1.4**



ISAC-SX

ISDN Subscriber Access
Controller

PEB 3086, V 1.4

Wired
Communications



Never stop thinking.

ABM[®], ACE[®], AOP[®], ARCOFI[®], ASM[®], ASP[®], DigiTape[®], DuSLIC[®], EPIC[®], ELIC[®], FALC[®], GEMINAX[®], IDEC[®], INCA[®], IOM[®], IPAT[®]-2, ISAC[®], ITAC[®], IWE[®], IWORX[®], MUSAC[®], MuSLIC[®], OCTAT[®], OptiPort[®], POTSWIRE[®], QUAT[®], QuadFALC[®], SCOUT[®], SICAT[®], SICOFI[®], SIDEC[®], SLICOFI[®], SMINT[®], SOCRATES[®], VINETIC[®], 10BaseV[®], 10BaseVX[®] are registered trademarks of Infineon Technologies AG. 10BaseS[™], EasyPort[™], VDSLite[™] are trademarks of Infineon Technologies AG. Microsoft[®] is a registered trademark of Microsoft Corporation. Linux[®] is a registered trademark of Linus Torvalds.

The information in this document is subject to change without notice.

Edition 2003-01-30

**Published by Infineon Technologies AG,
St.-Martin-Strasse 53,
81669 München, Germany**

**© Infineon Technologies AG 2003.
All Rights Reserved.**

Attention please!

The information herein is given to describe certain components and shall not be considered as warranted characteristics.

Terms of delivery and rights to technical change reserved.

We hereby disclaim any and all warranties, including but not limited to warranties of non-infringement, regarding circuits, descriptions and charts stated herein.

Infineon Technologies is an approved CECC manufacturer.

Information

For further information on technology, delivery terms and conditions and prices please contact your nearest Infineon Technologies Office in Germany or our Infineon Technologies Representatives worldwide (www.infineon.com).

Warnings

Due to technical requirements components may contain dangerous substances. For information on the types in question please contact your nearest Infineon Technologies Office.

Infineon Technologies Components may only be used in life-support devices or systems with the express written approval of Infineon Technologies, if a failure of such components can reasonably be expected to cause the failure of that life-support device or system, or to affect the safety or effectiveness of that device or system. Life support devices or systems are intended to be implanted in the human body, or to support and/or maintain and sustain and/or protect human life. If they fail, it is reasonable to assume that the health of the user or other persons may be endangered.

Table of Contents		Page
1	Overview	13
1.1	Features	17
1.2	Logic Symbol	19
1.3	Typical Applications	20
2	Pin Configuration	21
3	Description of Functional Blocks	30
3.1	General Functions and Device Architecture	30
3.2	Microcontroller Interfaces	32
3.2.1	Serial Control Interface (SCI)	33
3.2.1.1	Programming Sequences	34
3.2.2	Parallel Microcontroller Interface	37
3.2.3	Interrupt Structure	39
3.2.4	Reset Generation	41
3.2.5	Timer Modes	43
3.2.6	Activation Indication via Pin ACL	45
3.3	S/T-Interface	46
3.3.1	S/T-Interface Coding	48
3.3.2	S/T-Interface Multiframe	50
3.3.3	Multiframe Synchronization (M-Bit)	52
3.3.4	Data Transfer and Delay between IOM-2 and S/T	55
3.3.5	Transmitter Characteristics	58
3.3.6	Receiver Characteristics	59
3.3.7	S/T Interface Circuitry	60
3.3.7.1	External Protection Circuitry	60
3.3.7.2	S-Transceiver Synchronization	62
3.3.8	S/T Interface Delay Compensation (TE/LT-T mode)	63
3.3.9	Level Detection Power Down	63
3.3.10	Transceiver Enable/Disable	64
3.3.11	Test Functions	64
3.4	Clock Generation	66
3.4.1	Description of the Receive PLL (DPLL)	69
3.4.2	Jitter	69
3.4.3	Oscillator Clock Output C768	70
3.5	Control of Layer-1	71
3.5.1	State Machine TE and LT-T Mode	73
3.5.1.1	State Transition Diagram (TE, LT-T)	73
3.5.1.2	States (TE, LT-T)	75
3.5.1.3	C/I Codes (TE, LT-T)	77
3.5.1.4	Infos on S/T (TE, LT-T)	79
3.5.2	State Machine LT-S Mode	80
3.5.2.1	State Transition Diagram (LT-S)	80

Table of Contents		Page
3.5.2.2	States (LT-S)	81
3.5.2.3	C/I Codes (LT-S)	82
3.5.2.4	Infos on S/T (LT-S)	83
3.5.3	State Machine NT Mode	84
3.5.3.1	State Transition Diagram (NT)	84
3.5.3.2	States (NT)	85
3.5.3.3	C/I Codes (NT)	86
3.5.4	Command/ Indicate Channel Codes (C/I) - Overview	88
3.6	Control Procedures	89
3.6.1	Example of Activation/Deactivation	89
3.6.2	Activation initiated by the Terminal	90
3.6.3	Activation initiated by the Network Termination NT	91
3.7	IOM-2 Interface	92
3.7.1	IOM-2 Handler	95
3.7.1.1	Controller Data Access (CDA)	97
3.7.2	Serial Data Strobe Signal and Strobed Data Clock	107
3.7.2.1	Serial Data Strobe Signal	107
3.7.2.2	Strobed IOM-2 Bit Clock	109
3.7.3	IOM-2 Monitor Channel	110
3.7.3.1	Handshake Procedure	111
3.7.3.2	Error Treatment	114
3.7.3.3	MONITOR Channel Programming as a Master Device	116
3.7.3.4	MONITOR Channel Programming as a Slave Device	117
3.7.3.5	Monitor Time-Out Procedure	118
3.7.3.6	MONITOR Interrupt Logic	119
3.7.4	C/I Channel Handling	119
3.7.5	D-Channel Access Control	121
3.7.5.1	TIC Bus D-Channel Access Control	121
3.7.5.2	S-Bus Priority Mechanism for D-Channel	123
3.7.5.3	S-Bus D-Channel Control in LT-T	126
3.7.5.4	D-Channel Control in the Intelligent NT (TIC- and S-Bus)	126
3.7.6	Activation/Deactivation of IOM-2 Interface	130
3.8	Auxiliary Interface	133
3.8.1	Mode Dependent Functions	133
3.8.2	Message Transfer Modes	136
3.8.3	Data Reception	137
3.8.3.1	Structure and Control of the Receive FIFO	137
3.8.3.2	Receive Frame Structure	144
3.8.4	Data Transmission	146
3.8.4.1	Structure and Control of the Transmit FIFO	146
3.8.4.2	Transmit Frame Structure	151
3.8.5	Access to IOM-2 Channels	151

Table of Contents		Page
3.8.6	Extended Transparent Mode	151
3.8.7	HDLC Controller Interrupts	153
3.9	Test Functions	154
4	Detailed Register Description	156
4.1	D-channel HDLC Control and C/I Registers	164
4.1.1	RFIFOD - Receive FIFO D-Channel	164
4.1.2	XFIFOD - Transmit FIFO D-Channel	164
4.1.3	ISTAD - Interrupt Status Register D-Channel	165
4.1.4	MASKD - Mask Register D-Channel	166
4.1.5	STARD - Status Register D-Channel	167
4.1.6	CMDRD - Command Register D-Channel	167
4.1.7	MODED - Mode Register	168
4.1.8	EXMD1- Extended Mode Register D-Channel 1	170
4.1.9	TIMR1 - Timer 1 Register	172
4.1.10	SAP1 - SAPI1 Register	172
4.1.11	SAP2 - SAPI2 Register	173
4.1.12	RBCLD - Receive Frame Byte Count Low D-Channel	173
4.1.13	RBCHD - Receive Frame Byte Count High D-Channel	173
4.1.14	TEI1 - TEI1 Register 1	174
4.1.15	TEI2 - TEI2 Register	174
4.1.16	RSTAD - Receive Status Register D-Channel	175
4.1.17	TMD -Test Mode Register D-Channel	177
4.1.18	CIR0 - Command/Indication Receive 0	177
4.1.19	CIX0 - Command/Indication Transmit 0	178
4.1.20	CIR1 - Command/Indication Receive 1	179
4.1.21	CIX1 - Command/Indication Transmit 1	179
4.2	Transceiver Registers	180
4.2.1	TR_CONF0 - Transceiver Configuration Register 0	180
4.2.2	TR_CONF1 - Transceiver Configuration Register 1	181
4.2.3	TR_CONF2 - Transmitter Configuration Register 2	181
4.2.4	TR_STA - Transceiver Status Register	183
4.2.5	TR_CMD - Transceiver Command Register	184
4.2.6	SQRR1 - S/Q-Channel Receive Register 1	185
4.2.7	SQXR1- S/Q-Channel TX Register 1	186
4.2.8	SQRR2 - S/Q-Channel Receive Register 2	186
4.2.9	SQXR2 - S/Q-Channel TX Register 2	186
4.2.10	SQRR3 - S/Q-Channel Receive Register 3	187
4.2.11	SQXR3 - S/Q-Channel TX Register 3	187
4.2.12	ISTATR - Interrupt Status Register Transceiver	187
4.2.13	MASKTR - Mask Transceiver Interrupt	188
4.2.14	TR_MODE - Transceiver Mode Register 1	188
4.3	Auxiliary Interface Registers	190

Table of Contents		Page
4.3.1	ACFG1 - Auxiliary Configuration Register 1	190
4.3.2	ACFG2 - Auxiliary Configuration Register 2	190
4.3.3	AOE - Auxiliary Output Enable Register	192
4.3.4	ARX - Auxiliary Interface Receive Register	192
4.3.5	ATX - Auxiliary Interface Transmit Register	193
4.4	IOM-2 and MONITOR Handler	194
4.4.1	CDAxy - Controller Data Access Register xy	194
4.4.2	XXX_TSDPxy - Time Slot and Data Port Selection for CHxy	195
4.4.3	CDAx_CR - Control Register Controller Data Access CH1x	196
4.4.4	TR_CR - Control Register Transceiver Data (IOM_CR.CI_CS=0) ...	197
4.4.5	BCH_CR - Control Register B-Channel Controller Data	198
4.4.6	DCI_CR - Control Register for D and CI1 Handler (IOM_CR.CI_CS=0)	199
4.4.7	MON_CR - Control Register Monitor Data	201
4.4.8	SDSx_CR - Control Register Serial Data Strobe x	202
4.4.9	IOM_CR - Control Register IOM Data	203
4.4.10	STI - Synchronous Transfer Interrupt	205
4.4.11	ASTI - Acknowledge Synchronous Transfer Interrupt	206
4.4.12	MSTI - Mask Synchronous Transfer Interrupt	206
4.4.13	SDS_CONF - Configuration Register for Serial Data Strokes	207
4.4.14	MCDA - Monitoring CDA Bits	207
4.4.15	MOR - MONITOR Receive Channel	208
4.4.16	MOX - MONITOR Transmit Channel	208
4.4.17	MOSR - MONITOR Interrupt Status Register	208
4.4.18	MOCR - MONITOR Control Register	209
4.4.19	MSTA - MONITOR Status Register	210
4.4.20	MCONF - MONITOR Configuration Register	210
4.5	Interrupt and General Configuration	211
4.5.1	ISTA - Interrupt Status Register	211
4.5.2	MASK - Mask Register	212
4.5.3	AUXI - Auxiliary Interrupt Status Register	212
4.5.4	AUXM - Auxiliary Mask Register	213
4.5.5	MODE1 - Mode1 Register	213
4.5.6	MODE2 - Mode2 Register	215
4.5.7	ID - Identification Register	216
4.5.8	SRES - Software Reset Register	216
4.5.9	TIMR2 - Timer 2 Register	217
4.6	B-Channel Registers	218
4.6.1	ISTAB - Interrupt Status Register B-Channel	218
4.6.2	MASKB - Mask Register B-Channel	219
4.6.3	STARB - Status Register B-Channel	219
4.6.4	CMDRB - Command Register B-channel	220

Table of Contents		Page
4.6.5	MODEB - Mode Register	221
4.6.6	EXMB - Extended Mode Register B-Channel	222
4.6.7	RAH1 - RAH1 Register	223
4.6.8	RAH2 - RAH2 Register	223
4.6.9	RBCLB - Receive Frame Byte Count Low B-Channel	224
4.6.10	RBCHB - Receive Frame Byte Count High B-Channel	224
4.6.11	RAL1 - RAL1 Register 1	225
4.6.12	RAL2 - RAL2 Register	225
4.6.13	RSTAB - Receive Status Register B-Channel	226
4.6.14	TMB -Test Mode Register B-Channel	227
4.6.15	RFIFOB - Receive FIFO B-Channel	228
4.6.16	XFIFOB - Transmit FIFO B-Channel	228
5	Electrical Characteristics	229
5.1	Absolute Maximum Ratings	229
5.2	DC Characteristics	230
5.3	Capacitances	231
5.4	Oscillator Specification	232
5.5	AC Characteristics	233
5.6	IOM-2 Interface Timing	234
5.7	Microcontroller Interface Timing	237
5.7.1	Serial Control Interface (SCI) Timing	237
5.7.2	Parallel Microcontroller Interface Timing	238
5.8	Multiframe Synchronisation Timing	242
5.9	Reset	243
5.10	S-Transceiver	244
5.11	Recommended Transformer Specification	245
5.12	Line Overload Protection	246
5.13	EMC / ESD Aspects	247
6	Package Outlines	248
7	Appendix	250

List of Figures		Page
Figure 1	Logic Symbol of the ISAC-SX	19
Figure 2	Applications of the ISAC-SX	20
Figure 3	Pin Configuration of the ISAC-SX	21
Figure 4	Functional Block Diagram of the ISAC-SX	31
Figure 5	Serial Control Interface Timing	33
Figure 6	Serial Control Interface Timing	34
Figure 7	Direct/Indirect Register Address Mode	38
Figure 8	Interrupt Status and Mask Registers	39
Figure 9	Reset Generation	41
Figure 10	Timer Interrupt Status Registers	43
Figure 11	Timer 1 Register	44
Figure 12	Timer 2 Register	44
Figure 13	ACL Indication of Activated Layer 1	45
Figure 14	ACL Configuration	45
Figure 15	Wiring Configurations in User Premises	47
Figure 16	S/T -Interface Line Code	48
Figure 17	Frame Structure at Reference Points S and T (ITU I.430)	49
Figure 18	Multiframe Synchronization Using the M-Bit	52
Figure 19	Sampling Time in LT-S / NT mode (M-Bit input)	53
Figure 20	Frame Relationship in LT-S / NT mode (M-Bit input)	53
Figure 21	Frame Relationship in TE / LT-T mode (M-Bit output)	54
Figure 22	Data Delay between IOM-2 and S/T Interface (TE mode only)	55
Figure 23	Data Delay between IOM-2 and S/T Interface with S/G Bit Evaluation (TE mode only)	56
Figure 24	Data Delay between IOM-2 and S/T Interface with 8 IOM Channels (LT-S/NT mode only)	57
Figure 25	Data Delay between IOM-2 and S/T Interface with 3 IOM Channels and Maximum Receive Delay(LT-S/NT mode only)	57
Figure 26	Equivalent Internal Circuit of the Transmitter Stage	58
Figure 27	Equivalent Internal Circuit of the Receiver Stage	59
Figure 28	Connection of Line Transformers and Power Supply to the ISAC-SX ..	60
Figure 29	External Circuitry for Transmitter	61
Figure 30	External Circuitry for Symmetrical Receivers	62
Figure 31	External Circuitry for Symmetrical Receivers	63
Figure 32	Disabling of S/T Transmitter	64
Figure 33	External Loop at the S/T-Interface	65
Figure 34	Clock System of the ISAC-SX	66
Figure 35	Phase Relationships of ISAC-SX Clock Signals	69
Figure 36	Buffered Oscillator Clock Output	70
Figure 37	Layer-1 Control	71
Figure 38	State Diagram Notation	72
Figure 39	State Transition Diagram (TE, LT-T)	74

List of Figures	Page
Figure 40	State Transition Diagram of Unconditional Transitions (TE, LT-T) . . . 75
Figure 41	State Transition Diagram (LT-S) 80
Figure 42	State Transition Diagram (NT) 84
Figure 43	Example of Activation/Deactivation Initiated by the Terminal 89
Figure 44	Example of Activation/Deactivation initiated by the Terminal (TE). Activation/Deactivation completely under Software Control 90
Figure 45	Example of Activation/Deactivation initiated by the Network Termination (NT). Activation/Deactivation completely under Software Control 91
Figure 46	IOM®-2 Frame Structure in Terminal Mode 93
Figure 47	Multiplexed Frame Structure of the IOM-2 Interface in Non-TE Timing Mode 94
Figure 48	Architecture of the IOM Handler (Example Configuration). 96
Figure 49	Data Access via CDAX1 and CDAX2 register pairs 98
Figure 50	Examples for Data Access via CDAXy Registers. 99
Figure 51	Data Access when Looping TSa from DU to DD 100
Figure 52	Data Access when Shifting TSa to TSb on DU (DD) 101
Figure 53	Example for Monitoring Data 102
Figure 54	Interrupt Structure of the Synchronous Data Transfer. 104
Figure 55	Examples for the Synchronous Transfer Interrupt Control with one enabled STIxy 105
Figure 56	Data Strobe Signal. 108
Figure 57	Strobed IOM-2 Bit Clock. Register SDS_CONF Programmed to 01H 109
Figure 58	Examples of MONITOR Channel Applications in IOM -2 TE Mode . . 110
Figure 59	MONITOR Channel Protocol (IOM-2) 112
Figure 60	Monitor Channel, Transmission Abort requested by the Receiver. . . 115
Figure 61	Monitor Channel, Transmission Abort requested by the Transmitter. 115
Figure 62	Monitor Channel, Normal End of Transmission 116
Figure 63	MONITOR Interrupt Structure 119
Figure 64	CIC Interrupt Structure. 121
Figure 65	Applications of TIC Bus in IOM-2 Bus Configuration 122
Figure 66	Structure of Last Octet of Ch2 on DU 123
Figure 67	Structure of Last Octet of Ch2 on DD 124
Figure 68	D-Channel Access Control on the S-Interface. 125
Figure 69	Data Flow for Collision Resolution Procedure in Intelligent NT 129
Figure 70	Deactivation of the IOM-2 Interface 130
Figure 71	Activation of the IOM-2 interface 131
Figure 72	RFIFO Operation 140
Figure 73	Data Reception Procedures. 142
Figure 74	Reception Sequence Example. 143
Figure 75	Receive Data Flow. 144
Figure 76	Data Transmission Procedure 149
Figure 77	Transmission Sequence Example 150

List of Figures	Page
Figure 78	Transmit Data Flow 151
Figure 79	Interrupt Status Registers of the HDLC Controllers 153
Figure 80	Layer 2 Test Loops 154
Figure 81	Register Mapping of the ISAC-SX 156
Figure 82	Oscillator Circuits 232
Figure 83	Input/Output Waveform for AC Tests 233
Figure 84	IOM-2 Timing (TE mode) 234
Figure 85	IOM-2 Timing (LT-S, LT-T, NT mode) 235
Figure 86	Definition of Clock Period and Width 236
Figure 87	SCI Interface 237
Figure 88	Microprocessor Read Cycle 238
Figure 89	Microprocessor Write Cycle 238
Figure 90	Multiplexed Address Timing 239
Figure 91	Non-Multiplexed Address Timing 239
Figure 92	Microprocessor Read Timing 240
Figure 93	Microprocessor Write Cycle 240
Figure 94	Non-Multiplexed Address Timing 241
Figure 95	Sampling Time in LT-S/NT Mode (M-Bit Input) 242
Figure 96	Reset Signal RES 243
Figure 97	Maximum Line Input Current 246
Figure 98	Transformer Circuitry 247

List of Tables		Page
Table 1	Comparison of the ISAC-SX with the Previous Version ISAC-S	14
Table 2	ISAC-SX Pin Definitions and Functions	22
Table 3	Host Interface Selection	32
Table 4	Header Byte Code	34
Table 5	Bus Operation Modes	37
Table 6	Reset Source Selection	42
Table 7	ISAC-SX Timers	43
Table 8	S/Q-Bit Position Identification and Multiframe Structure	50
Table 9	Clock Modes	67
Table 10	Examples for Synchronous Transfer Interrupts	104
Table 11	CDA Register Combinations with Correct Read/Write Access	106
Table 12	Transmit Direction	111
Table 13	Receive Direction	111
Table 14	ISAC-SX Configuration Settings in Intelligent NT Applications	127
Table 15	AUX Pin Functions	133
Table 16	IOM-2 Channel Selection	134
Table 17	HDLC Controller Address Range	135
Table 18	Receive Byte Count with RBC11...0 in the RBCHx/RBCLx Registers	139
Table 19	Receive Information at RME Interrupt	145
Table 20	XPR Interrupt (availability of XFIFOx) after XTF, XME Commands . .	147

1 Overview

The ISDN Subscriber Access Controller ISAC-SX integrates a D-channel HDLC controller and a four wire S/T interface used to link voice/data terminals to the ISDN. It is based on the ISAC-S PEB 2086, and provides enhanced features and functionality.

It includes the S-transceiver (Layer 1), an HDLC controller for the D-channel and one B-channel protocol controller (HDLC or transparent) with reduced features dedicated for firmware download via the B-channel.

The system integration is simplified by several configurations of the parallel microcontroller interface selected via pin strapping. They include multiplexed and demultiplexed interface selection as well as the optional indirect register access mechanism which reduces the number of necessary registers in the address space to 2 locations. The ISAC-SX also provides a serial control interface (SCI).

The FIFO size of the cyclic D-channel buffer is 64 bytes per direction with programmable block size (threshold). Besides TE mode the S-transceiver supports other terminal relevant operation modes like line termination subscriber side (LT-S), line termination trunk side (LT-T) and NT applications (NT, Intelligent NT mode).

An auxiliary I/O port has been added with interrupt capabilities on two input lines. These programmable I/O lines may be used to connect peripheral components to the ISAC-SX which need software control or have to forward status information to the host.

Three programmable LED outputs can be used to indicate certain status information, one of them is capable to indicate the activation status of the S-interface automatically.

The ISAC-SX is produced in advanced CMOS technology.

Table 1 Comparison of the ISAC-SX with the Previous Version ISAC-S

	ISAC-SX PEB 3086	ISAC-S PEB 2086
Operating modes	TE, LT-T, LT-S, NT, Int. NT	TE, LT-T, LT-S, NT
Supply voltage	3.3 V \pm 5%	5 V \pm 5%
Technology	CMOS	CMOS
Package	P-MQFP-64 / P-TQFP-64	P-MQFP-64 / P-LCC-44
Transceiver Transformer ratio for the transmitter receiver	1:1 1:1	2:1 2:1
Test Functions	- Dig. loop via Layer 2 (TLP) - Layer 1 disable (DIS_TR) - Analog loop (LP_A- bit EXLP- bit, ARL)	- Dig. loop via Layer 2(TLP) - Layer 1 disable (DIS_TR) - Analog loop (ARL)
Microcontroller Interface	Serial interface (SCI) 8-bit parallel interface: Motorola Mux Siemens/Intel Mux Siemens/Intel Non-Mux direct/ indirect Addressing	Not provided 8-bit parallel interface: Motorola Mux Siemens/Intel Mux Siemens/Intel Non-Mux
Command structure of the register access (SCI)	Header/address/data	Address/data
Crystal	7.68 MHz	7.68 MHz
Buffered 7.68 MHz output	Provided	Not provided
Controller data access to IOM-2 timeslots	All timeslots; various possibilities of data access	Restricted access to B- and IC-channel
Data control and manipulation	Various possibilities of data control and data manipulation (enable/disable, shifting, looping, switching)	B- and IC-channel looping
IOM-2		

	ISAC-SX PEB 3086	ISAC-S PEB 2086
IOM-2 Interface	Double clock (DCL), bit clock (BCL), serial data strobe 1 (SDS1) serial data strobe 2 (SDS2)	Double clock (DCL), bit clock (BCL), serial data strobe (SDS)
Monitor channel programming	Provided (MON0, 1, 2, ..., 7)	Provided (MON0 or 1)
C/I channels	C10 (4bit), C11 (4/6bit)	C10 (4bit), C11 (6bit)
Layer 1 state machine	With changes for correspondence with the actual ITU specification	
Layer 1 state machine in software	Possible	Not possible
Support of IDSL (144kBit/s)	Provided (HDLC controller access, SDS1/2 signals active)	Not provided
D-channel HDLC support	D- and B-channel timeslots; non-auto mode, transparent mode 0-2, extended transparent mode	D-channel timeslot; auto mode, non-auto mode, transparent mode 1-3
D-channel FIFO size	64 bytes cyclic buffer per direction with programmable FIFO thresholds	2x32 bytes buffer per direction
FW download support	One B-channel controller	Not provided
HDLC support (B-channel)	D- and B-channel timeslots; non-auto mode, transparent mode 0-2, extended transparent mode	Not provided
FIFO size (B-channel)	128 bytes cyclic buffer per direction with programmable FIFO thresholds (8 or 16 bytes)	Not provided
Reset Signals	$\overline{\text{RES}}$ input signal $\overline{\text{RSTO}}$ output signal	RST input/output signal

	ISAC-SX PEB 3086	ISAC-S PEB 2086
Reset Sources	$\overline{\text{RES}}$ Input Watchdog C/I Code Change $\overline{\text{EAW}}$ Pin Software Reset	RST Input Watchdog C/I Code Change EAW Pin
Interrupt Output Signals	$\overline{\text{INT}}$ low active (open drain) by default, reprogrammable to high active (push-pull)	Low active $\overline{\text{INT}}$
Pin SCLK	1.536 MHz	512 kHz

ISAC-SX

ISDN Subscriber Access Controller

PEB 3086

V 1.4

1.1 Features

- Full duplex 2B + D S/T interface transceiver according to ITU-T I.430
- Successor of ISAC-S PEB 2086 in 3.3 V technology
- 8-bit parallel microcontroller interface, Motorola and Siemens/Intel bus type multiplexed or non-multiplexed, direct-/indirect register addressing
- Serial control interface (SCI)
- Microcontroller access to all IOM-2 timeslots
- Various types of protocol support (Non-auto mode, transparent mode, extended transparent mode)
- One D-channel HDLC controller with 64 byte FIFOs per direction
- One B-channel HDLC controller with reduced functionality (e.g. for firmware upgrades)
- IOM-2 interface in TE, LT-T, LT-S and NT mode, single/double clocks and two strobe signals
- D-channel priority handler on IOM-2 for intelligent NT applications
- Monitor channel handler (master/slave)
- IOM-2 MONITOR and C/I-channel protocol to control peripheral devices
- Conversion of the frame structure between the S/T-interface and IOM-2
- Receive timing recovery
- D-channel access control
- Activation and deactivation procedures with automatic activation from power down state
- Access to S and Q bits of S/T-interface
- Adaptively switched receive thresholds

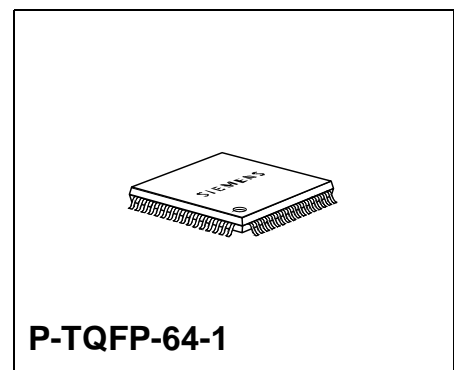
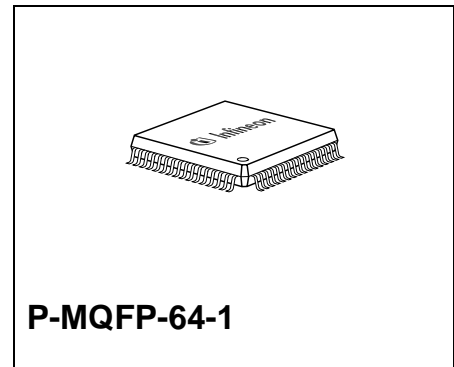

Type	Package
PEB 3086 H	P-MQFP-64-1
PEB 3086 F	P-TQFP-64-1

- Auxiliary Interface with general purpose I/O pins and LED drivers
- Two programmable timers
- Watchdog timer
- Software Reset
- Multiframe Synchronization
- Test loops
- Sophisticated power management for restricted power mode
- Power supply 3.3 V
- 3.3 V output drivers, inputs are 5 V safe
- Advanced CMOS technology

1.2 Logic Symbol

The logic symbol gives an overview of the ISAC-SX functions. It must be noted that not all functions are available simultaneously, but depend on the selected mode.

Pins which are marked with a “ * “ are multiplexed and not available in all modes.

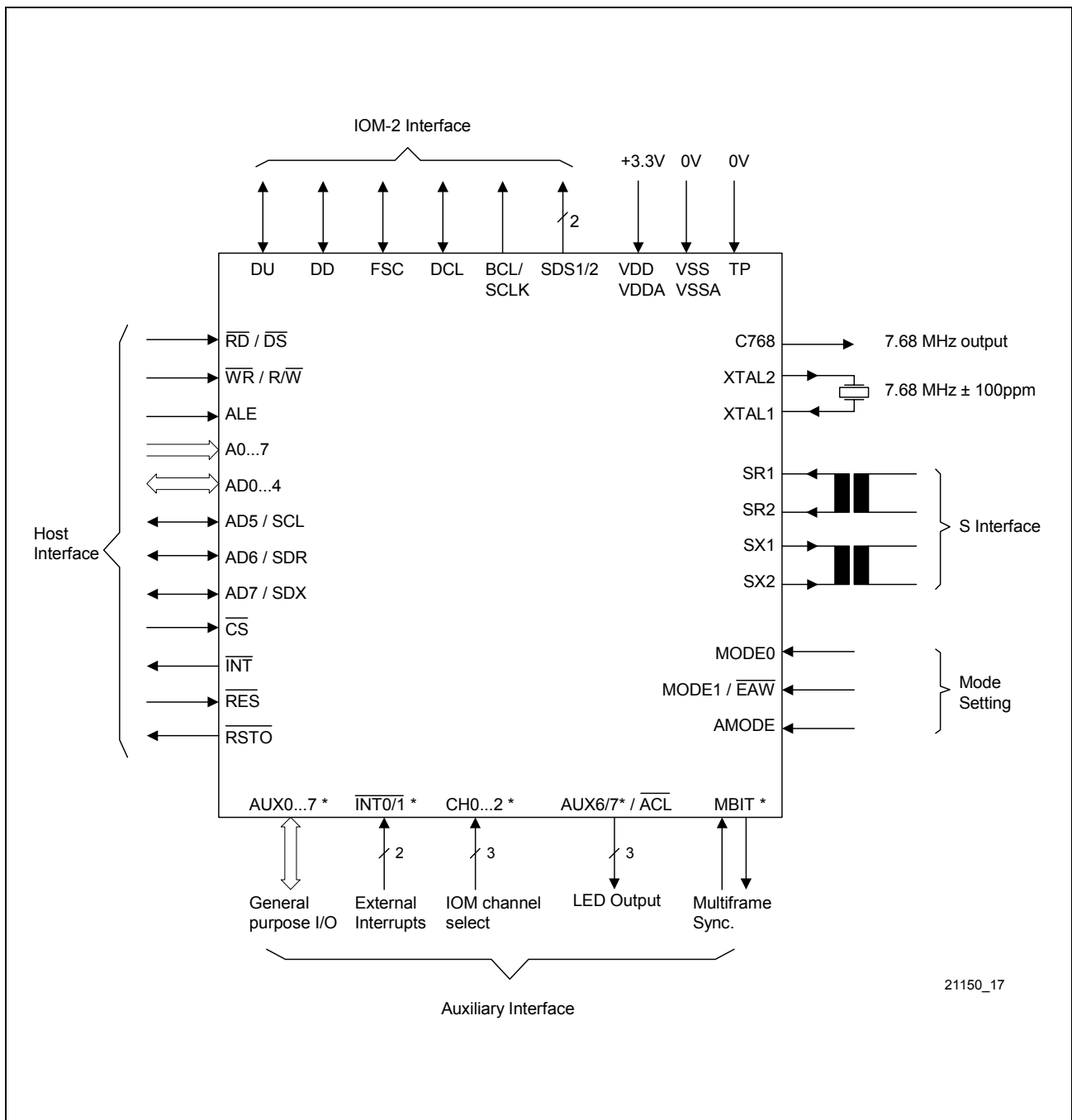

Figure 1 Logic Symbol of the ISAC-SX

1.3 Typical Applications

The ISAC-SX is designed for the user area of the ISDN basic access, especially for subscriber terminal equipment and for exchange equipment with S interface.

Figure 2 illustrates the general application fields of the ISAC-SX.

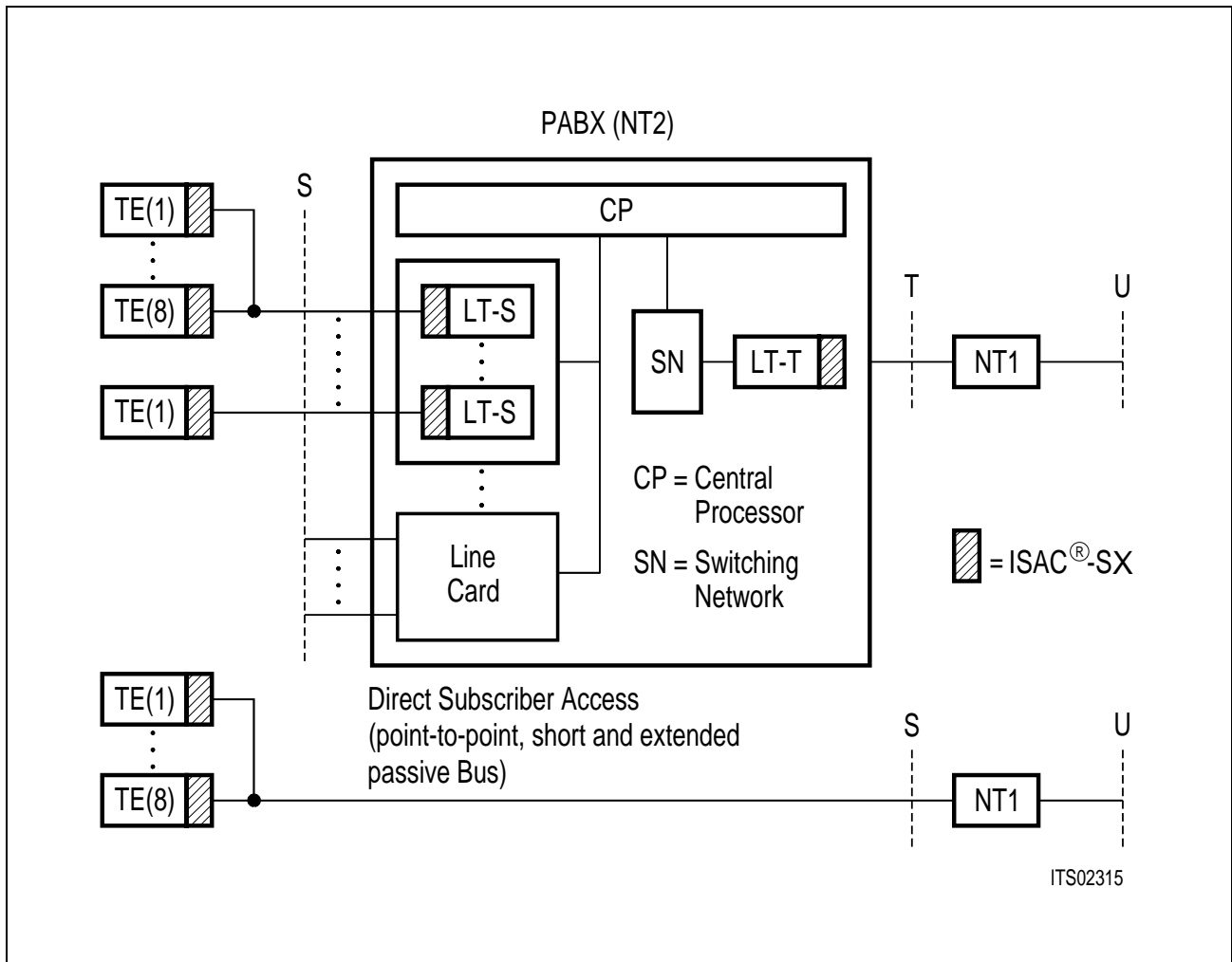

Figure 2 Applications of the ISAC-SX

2 Pin Configuration

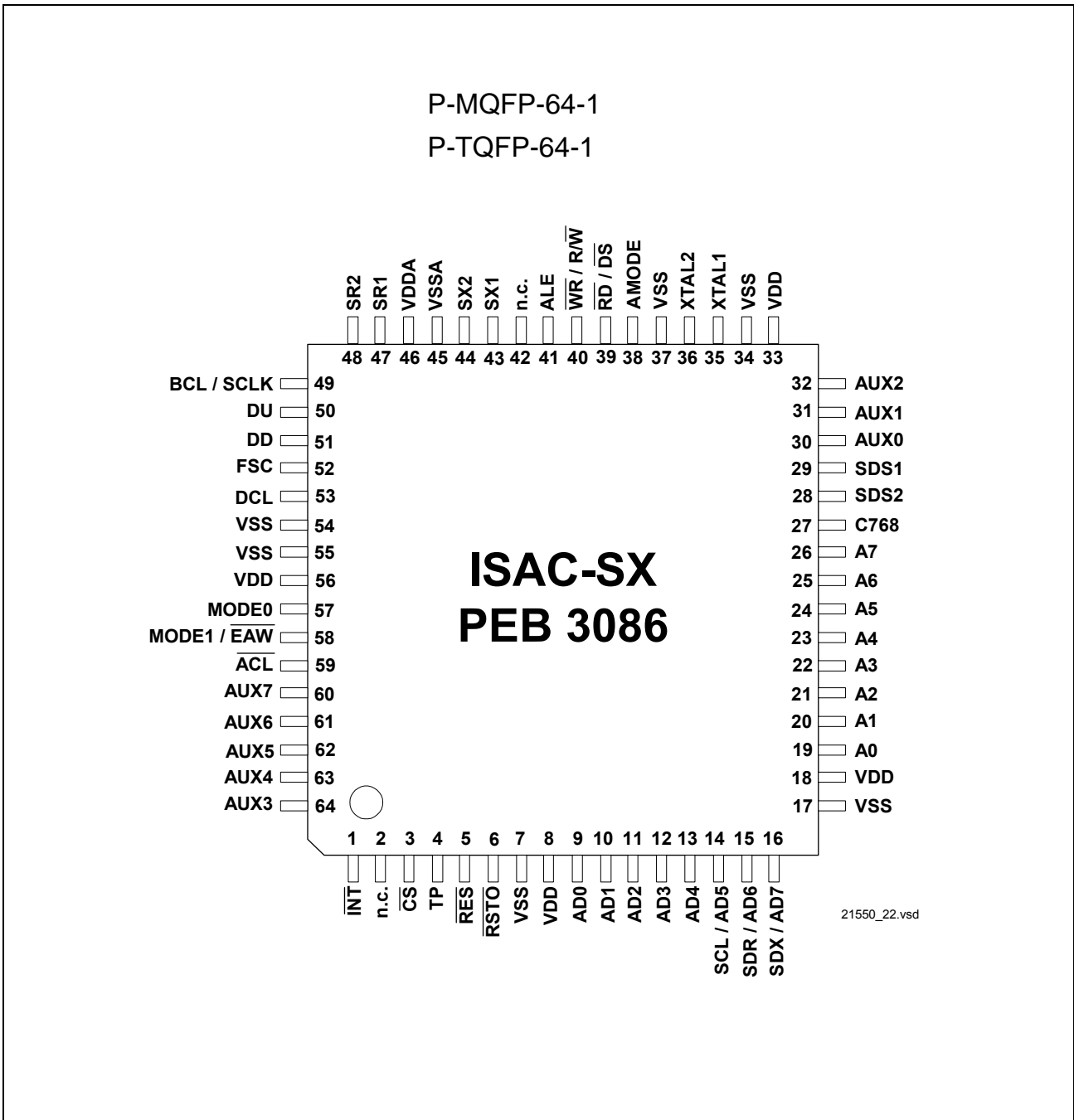

Figure 3 Pin Configuration of the ISAC-SX

Table 2 ISAC-SX Pin Definitions and Functions

Pin No. MQFP-64 TQFP-64	Symbol	Input (I) Output (O) Open Drain (OD)	Function
-------------------------------	--------	---	----------

Host Interface

19	A0	I	<ul style="list-style-type: none"> • Non-Multiplexed Bus Mode: Address Bus Address bus transfers addresses from the microcontroller to the ISAC-SX. For indirect address mode only A0 is valid (A1-A7 to be connected to VDD). • Multiplexed Bus Mode: Not used in multiplexed bus mode. In this case A0-A7 should directly be connected to VDD.
20	A1	I	
21	A2	I	
22	A3	I	
23	A4	I	
24	A5	I	
25	A6	I	
26	A7	I	
9	AD0	I/O	<ul style="list-style-type: none"> • Multiplexed Bus Mode: Address/data bus Transfers addresses from the microcontroller to the ISAC-SX and data between the microcontroller and the ISAC-SX. • Non-Multiplexed Bus Mode: Data bus Transfers data between the microcontroller and the ISAC-SX.
10	AD1	I/O	
11	AD2	I/O	
12	AD3	I/O	
13	AD4	I/O	
14	AD5	I/O	<ul style="list-style-type: none"> • Multiplexed Bus Mode: Address/data bus Address/data line AD5 if the parallel interface is selected. • Non-Multiplexed Bus Mode: Data bus Data line D5 if the parallel interface is selected.
	SCL	I	

Table 2 ISAC-SX Pin Definitions and Functions (cont'd)

Pin No. MQFP-64 TQFP-64	Symbol	Input (I) Output (O) Open Drain (OD)	Function
15	AD6 SDR	I/O I	<ul style="list-style-type: none"> • Multiplexed Bus Mode: Address/data bus Address/data line AD6 if the parallel interface is selected. • Non-Multiplexed Bus Mode: Data bus Data line D6 if the parallel interface is selected. SCI - Serial Data Receive Receive data line of the SCI interface if a serial interface is selected.
16	AD7 SDX	I/O OD	<ul style="list-style-type: none"> • Multiplexed Bus Mode: Address/data bus Address/data line AD7 if the parallel interface is selected. • Non-Multiplexed Bus Mode: Data bus Data line D7 if the parallel interface is selected. SCI - Serial Data Transmit Transmit data line of the SCI interface if a serial interface is selected.
39	\overline{RD} \overline{DS}	I I	Read Indicates a read access to the registers (Siemens/Intel bus mode). Data Strobe The rising edge marks the end of a valid read or write operation (Motorola bus mode).
40	\overline{WR} R/ \overline{W}	I I	Write Indicates a write access to the registers (Siemens/Intel bus mode). Read/Write A HIGH identifies a valid host access as a read operation and a LOW identifies a valid host access as a write operation (Motorola bus mode).

Table 2 ISAC-SX Pin Definitions and Functions (cont'd)

Pin No. MQFP-64 TQFP-64	Symbol	Input (I) Output (O) Open Drain (OD)	Function
41	ALE	I	Address Latch Enable A HIGH on this line indicates an address on the external address/data bus (multiplexed bus type only). ALE also selects the microcontroller interface bus type (multiplexed or non multiplexed).
3	$\overline{\text{CS}}$	I	Chip Select A low level indicates a microcontroller access to the ISAC-SX.
1	$\overline{\text{INT}}$	OD (O)	Interrupt Request $\overline{\text{INT}}$ becomes active low (open drain) if the ISAC-SX requests an interrupt. The polarity can be reprogrammed to high active with push-pull characteristic.
5	$\overline{\text{RES}}$	I	Reset A LOW on this input forces the ISAC-SX into a reset state.
38	AMODE	I	Address Mode Selects between direct (0) and indirect (1) register access mode.

IOM-2 Interface

52	FSC	I/O	Frame Sync 8-kHz frame synchronization signal.
53	DCL	I/O	Data Clock IOM-2 interface clock signal (double clock) (e.g 1.536 MHz in TE mode).

Pin Configuration

Table 2 ISAC-SX Pin Definitions and Functions (cont'd)

Pin No. MQFP-64 TQFP-64	Symbol	Input (I) Output (O) Open Drain (OD)	Function
49	BCL/ SCLK	O	Bit Clock/S-Clock TE-Mode: Bit clock output, identical to IOM-2 data rate (DCL/2). LT-T Mode: 1.536 MHz output synchronous to S-interface. NT / LT-S Mode: Bit clock output derived from the DCL input clock divided by 2.
51	DD	I/O (OD)	Data Downstream IOM-2 data signal in downstream direction.
50	DU	I/O (OD)	Data Upstream IOM-2 data signal in upstream direction.
29	SDS1	O	Serial Data Strobe 1 Programmable strobe signal for time slot and/or D-channel indication on IOM-2.
28	SDS2	O	Serial Data Strobe 2 Programmable strobe signal for time slot and/or D-channel indication on IOM-2.

Auxiliary Interface

30 31 32	AUX0 AUX1 AUX2	I/O (OD) I/O (OD) I/O (OD)	<ul style="list-style-type: none"> • TE-Mode: Auxiliary Port 0 - 2 (input/output) These pins are individually programmable as general input/output. The state of the pin can be read from (input) / written to (output) a register. • LT-T/LT-S/NT Mode: CH0-2 - IOM-2 Channel Select (input) These pins select one of eight channels on the IOM-2 interface.
64	AUX3	I/O (OD)	Auxiliary Port 3 (input/output) This pin is programmable as general input/output. The state of the pin can be read from (input) / written to (output) a register.

Table 2 ISAC-SX Pin Definitions and Functions (cont'd)

Pin No. MQFP-64 TQFP-64	Symbol	Input (I) Output (O) Open Drain (OD)	Function
63	AUX4	I/O (OD)	<ul style="list-style-type: none"> • Auxiliary Port 4 (input/output) This pin is programmable as general input/output. The state of the pin can be read from (input) / written to (output) a register. • MBIT (input/output) If ACFG2.A4SEL is set to '1', pin AUX4 is used as M-bit input (LT-S / NT / Int. NT mode) or as M-bit output (TE / LT-T mode) for multiframe synchronization.
62	AUX5	I/O (OD)	<ul style="list-style-type: none"> • Auxiliary Port 5 (input/output) This pin is programmable as general input/output. The state of the pin can be read from (input) / written to (output) a register. • FBOUT - FSC/BCL output If ACFG2.A5SEL is set to '1', pin AUX5 outputs either an FSC signal or a BCL signal selected via ACFG2.FBS.
61	AUX6	I/O (OD)	<p>$\overline{\text{INT0}}$ This pin is programmable as general input/output. The state of the pin can be read from (input) / written to (output) a register. Additionally, as input it can generate a maskable interrupt to the host, which is either edge or level triggered. An internal pull up resistor is connected to this pin (open drain mode only), if push pull characteristic is selected no pull up is available. As output an LED can directly be connected to this pin.</p>

Table 2 ISAC-SX Pin Definitions and Functions (cont'd)

Pin No. MQFP-64 TQFP-64	Symbol	Input (I) Output (O) Open Drain (OD)	Function
60	AUX7	I/O (OD)	<p>INT1 This pin is programmable as general input/output. The state of the pin can be read from (input) / written to (output) a register. Additionally, as input it can generate a maskable interrupt to the host, which is either edge or level triggered. An internal pull up resistor is connected to this pin (open drain mode only), if push pull characteristic is selected no pull up is available. As output an LED can directly be connected to this pin.</p> <p>SGO Instead of the above described function, AUX7 can also be programmed to output the S/G bit signal from the IOM-2 DD line.</p>

Miscellaneous

43	SX1	O	S-Bus Transmitter Output (positive)
44	SX2	O	S-Bus Transmitter Output (negative)
47	SR1	I	S-Bus Receiver Input
48	SR2	I	S-Bus Receiver Input
35	XTAL1	I	<p>Crystal 1 Connection for a crystal or used as external clock input. 7.68 MHz clock or crystal required.</p>
36	XTAL2	O	<p>Crystal 2 Connection for a crystal. Not connected if an external clock is supplied to XTAL1.</p>
57	MODE0	I	<p>Mode 0 Select A LOW selects TE-mode and a HIGH selects LT-T / LT-S mode (see MODE1/EAW).</p>

Table 2 ISAC-SX Pin Definitions and Functions (cont'd)

Pin No. MQFP-64 TQFP-64	Symbol	Input (I) Output (O) Open Drain (OD)	Function
58	MODE1 $\overline{\text{EAW}}$	I I	The pin function depends on the setting of MODE0. If MODE0=1: Mode 1 Select A LOW selects LT-T mode and a HIGH selects LT-S mode. If MODE0=0: External Awake If a falling edge on this input is detected, the ISAC-SX generates an interrupt and, if enabled, a reset pulse.
59	$\overline{\text{ACL}}$	O	Activation LED This pin can either function as a programmable output or it can automatically indicate the activated state of the S interface by a logic '0'. An LED with <u>pre-resistance</u> may directly be connected to $\overline{\text{ACL}}$.
27	C768	O	Clock Output A 7.68 MHz clock is output to support other devices. This clock is not synchronous to the S interface.
6	$\overline{\text{RSTO}}$	OD	Reset Output Low active reset output, either from a watchdog timeout or programmed by the host.
4	TP	I	Test Pin Must be connected to V_{SS} .
2, 42	n.c.	I	not connected

Power Supply

8, 18, 33, 56	V_{DD}	–	Digital Power Supply Voltage (3.3 V ± 5 %)
46	V_{DDA}	–	Analog Power Supply Voltage (3.3 V ± 5 %)

Table 2 ISAC-SX Pin Definitions and Functions (cont'd)

Pin No. MQFP-64 TQFP-64	Symbol	Input (I) Output (O) Open Drain (OD)	Function
7, 17, 34, 37, 54, 55	V_{SS}	–	Digital ground (0 V)
45	V_{SSA}	–	Analog ground (0 V)

3 Description of Functional Blocks

3.1 General Functions and Device Architecture

Figure 4 shows the architecture of the ISAC-SX containing the following functions:

- S/T-interface transceiver supporting the modes TE, LT-T, LT-S, NT and Intelligent NT
- Different host interface modes:
 - Parallel microcontroller interface (Siemens/Intel multiplexed, Siemens/Intel non multiplexed, Motorola modes)
 - Serial Control Interface (SCI)
- Optional indirect register address mode reduces number of registers to be accessed to two locations
- One D-channel HDLC-controller with 64 byte FIFOs per direction with programmable FIFO block size (threshold) of 4, 8, 16 or 32 byte for receive direction and 16 or 32 byte for transmit direction
- Support of firmware download via one B-channel HDLC-controller and FIFOs with reduced functionality
- IOM-2 interface for terminal (TE mode), linecard (LT-T or LT-S) or NT applications
- IOM handler with controller data access registers (CDA) allows flexible access to IOM timeslots for reading/writing, looping and shifting data
- Synchronous transfer interrupts (STI) allow controlled access to IOM timeslots
- Flexible timeslot assignment of HDLC controllers on IOM for IDSL support
- MONITOR channel handler on IOM-2 for master mode, slave mode or data exchange
- C/I-channel handler and TIC bus access controller
- D-channel access mechanism in all modes
- D-channel priority handler on IOM-2 for intelligent NT applications
- Capability to control the start of the multiframe for synchronization from external signals (M-bit input pin in LT-S/NT mode, M-bit output pin in TE, LT-T mode)
- Auxiliary interface with interrupt and general purpose I/O lines and 2 LED drivers
- LED connected to pin \bar{ACL} indicates S-interface activation status automatically or can be controlled by the host
- Level detect circuit on the S interface reduces power consumption in power down mode
- Two timers for periodic or single interrupts (periods between 1 ms and 14.336 s)
- Clock and timing generation
- Digital PLL to synchronize the transceiver to the S/T interface
- Buffered 7.68 MHz oscillator clock output allows connection of further devices and saves another crystal on the system board
- Reset generation (watchdog timer)

Description of Functional Blocks

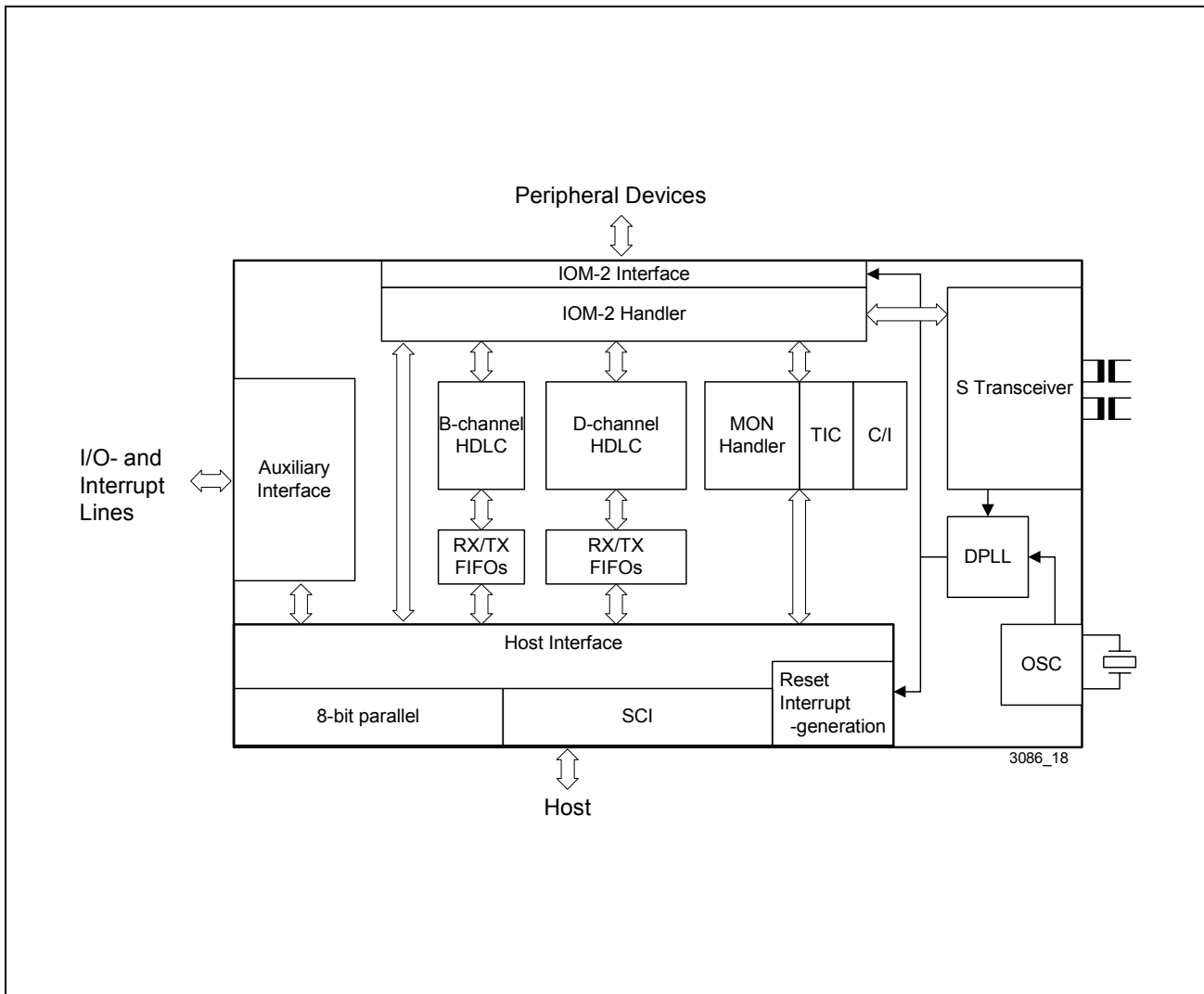

Figure 4 Functional Block Diagram of the ISAC-SX

3.2 Microcontroller Interfaces

The ISAC-SX supports a serial or a parallel microcontroller interface. For applications where no controller is connected to the ISAC-SX microcontroller interface programming is done via the IOM-2 MONITOR channel from a master device. In such applications the ISAC-SX operates in the IOM-2 slave mode (refer to the corresponding chapter of the IOM-2 MONITOR handler). This mode is suitable for control functions (e.g. programming registers of the S/T transceiver), but the bandwidth is not sufficient for access to the HDLC controllers.

The interface selections are all done by pinstrapping (see [Table 3](#)). The selection pins are evaluated when the reset input \overline{RES} is active. For the pin levels stated in the tables the following is defined:

- 'High', 'Low': dynamic pin; value must be 'High' or 'Low' only during reset
- V_{DD} , V_{SS} : static pin; pin must statically be strapped to 'High' or 'Low' level
- edge: dynamic pin; any transition ('High' to 'Low', 'Low' to 'High') has occurred

Table 3 Host Interface Selection

PINS		Serial/Parallel Interface	PINS		Interface Type/Mode
\overline{WR} ($\overline{R/W}$)	\overline{RD} (\overline{DS})		CS	ALE	
'High'	'High'	Parallel	'High'	V_{DD}	Motorola
				V_{SS}	Siemens/Intel Non-Mux
				edge	Siemens/Intel Mux
V_{SS}	V_{SS}	Serial	'High'	V_{SS}	Serial Control Interface(SCI)
		No Host Interface	V_{SS}	V_{SS}	IOM-2 MONITOR Channel (Slave Mode)

Note: For a selected interface mode which doesn't need all input selection and address pins the unused pins must be tied to V_{DD} or V_{SS} .

The interfaces contain all circuitry necessary for the access to programmable registers, status registers and HDLC FIFOs. The mapping of all these registers can be found in [Chapter 4](#).

The microcontroller interface also provides an interrupt request at pin \overline{INT} which is low active by default but can be reprogrammed to high active, a reset input pin \overline{RES} and a reset output pin \overline{RSTO} .

The interrupt request pin \overline{INT} becomes active if the ISAC-SX requests an interrupt and this can occur at any time.

3.2.1 Serial Control Interface (SCI)

The serial control interface (SCI) is compatible to the SPI interface of Motorola or Siemens C510 family of microcontrollers.

The SCI consists of 4 lines: SCL, SDX, SDR and \overline{CS} . Data is transferred via the lines SDR and SDX at the rate given by SCL. The falling edge of \overline{CS} indicates the beginning of a serial access to the registers. The ISAC-SX latches incoming data at the rising edge of SCL and shifts out at the falling edge of SCL. Each access must be terminated by a rising edge of \overline{CS} . Data is transferred in groups of 8 bits with the MSB first.

Figure 5 shows the timing of a one byte read/write access via the serial control interface.

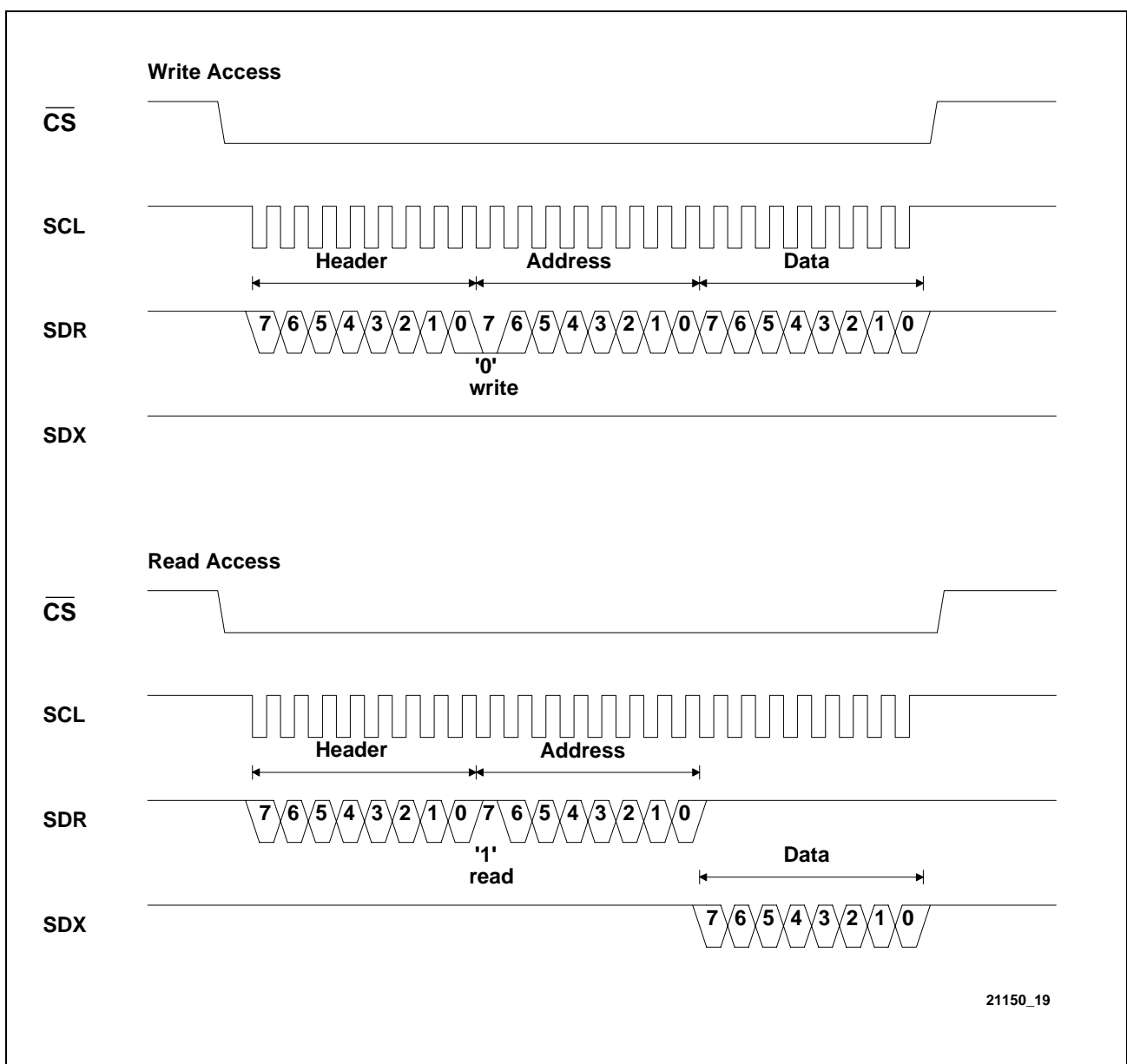

Figure 5 Serial Control Interface Timing

3.2.1.1 Programming Sequences

The basic structure of a read/write access to the ISAC-SX registers via the serial control interface is shown in **Figure 6**.

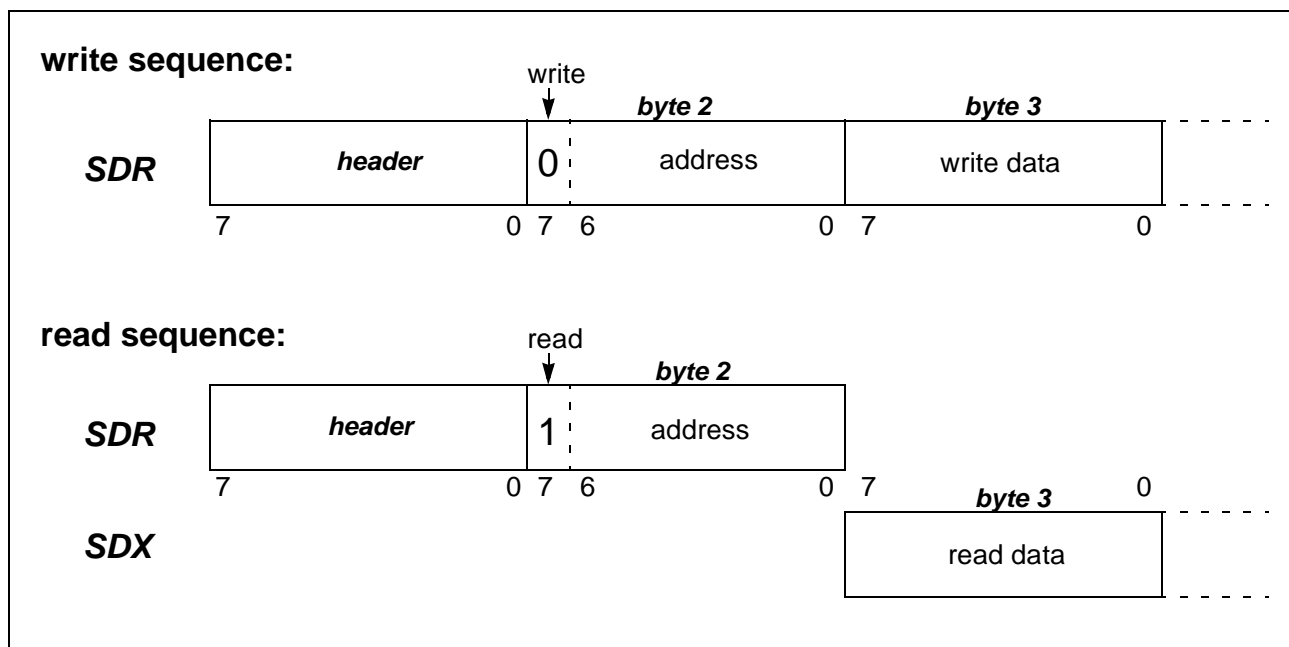

Figure 6 Serial Control Interface Timing

A new programming sequence starts with the transfer of a header byte. The header byte specifies different programming sequences allowing a flexible and optimized access to the individual functional blocks of the ISAC-SX.

The possible sequences for access to the complete address range 00_H-7F_H are listed in **Table 4** and described after that.

Table 4 Header Byte Code

Header Byte	Sequence	Sequence Type
40 _H /44 _H	Adr-Data-Adr-Data	Alternating Read/Write (non-interleaved)
48 _H /4C _H		Alternating Read/Write (interleaved)
43 _H /47 _H	Adr-Data-Data-Data	Read-only/Write-only (constant address)
41 _H /45 _H		Read and following Write-only (non-interleaved)
49 _H /4D _H		Read and following Write-only (interleaved)

Note: In order to access the address range 00_H-7F_H bit 2 of the header byte must be set to '0' (header bytes 40_H, 48_H, 43_H, 41_H, 49_H), and for the addresses 80_H-FF_H bit 2 must be set to '1' (header bytes 44_H, 4C_H, 47_H, 45_H, 4D_H).

Description of Functional Blocks

Header 40_H: Non-interleaved A-D-A-D Sequences

The non-interleaved A-D-A-D sequence gives direct read/write access to the complete address range and can have any length. In this mode SDX and SDR can be connected together allowing data transmission on one line.

Example for a read/write access with header 40_H:

SDR	header	wradr	wrdata	rdadr		rdadr		wradr	wrdata	
SDX					rddata		rdata			

Header 48_H: Interleaved A-D-A-D Sequences

The interleaved A-D-A-D sequence gives direct read/write access to the complete address range and can have any length. This mode allows a time optimized access to the registers by interleaving the data on SDX and SDR (SDR and SDX must not be connected together).

Example for a read/write access with header 48_H:

SDR	header	wradr	wrdata	rdadr	rdadr	wradr	wrdata			
SDX					rddata	rddata				

Header 43_H: Read-/Write- only A-D-D-D Sequence (Constant Address)

This mode can be used for a fast access to the HDLC FIFO data. Any address (rdadr, wradr) in the range 00_H-1F_H and 6A_H/7A_H gives access to the current FIFO location selected by an internal pointer which is automatically incremented with every data byte following the first address byte. The sequence can have any length and is terminated by the rising edge of \overline{CS} .

Example for a write access with header 43_H:

SDR	header	wradr	wrdata	wrdata	wrdata	wrdata	wrdata	wrdata	wrdata	
			(wradr)	(wradr)	(wradr)	(wradr)	(wradr)	(wradr)	(wradr)	
SDX										

Example for a read access with header 43_H:

SDR	header	rdadr								
SDX			rddata	rddata	rddata	rddata	rddata	rddata	rddata	
			(rdadr)	(rdadr)	(rdadr)	(rdadr)	(rdadr)	(rdadr)	(rdadr)	

Description of Functional Blocks

Header 41_H: Non-interleaved A-D-D-D Sequence

This sequence allows in front of the A-D-D-D write access a non-interleaved A-D-A-D read access. This mode is useful for reading status information before writing to the HDLC XFIFO. The termination condition of the read access is the reception of the wradr. The sequence can have any length and is terminated by the rising edge of \overline{CS} .

Example for a read/write access with header 41_H:

SDR	header	rdadr		rdadr		wradr	wrdata (wradr)	wrdata (wradr)	wrdata (wradr)	
SDX			rddata		rddata					

Header 49_H: Interleaved A-D-D-D Sequence

This sequence allows in front of the A-D-D-D write access an interleaved A-D-A-D read access. This mode is useful for reading status information before writing to the HDLC XFIFO. The termination condition of the read access is the reception of the wradr. The sequence can have any length and is terminated by the rising edge of the \overline{CS} line.

Example for a read/write access with header 49_H:

SDR	header	rdadr	rdadr	wradr	wrdata (wradr)	wrdata (wradr)	wrdata (wradr)			
SDX			rddata	rddata						

3.2.2 Parallel Microcontroller Interface

The 8-bit parallel microcontroller interface with address decoding on chip allows easy and fast microcontroller access.

The parallel interface of the ISAC-SX provides three types of μ P buses which are selected via pin ALE. The bus operation modes with corresponding pins are listed in [Table 5](#).

Table 5 Bus Operation Modes

	Bus Mode	Pin ALE	Control Pins
(1)	Motorola	V _{DD}	\overline{CS} , $\overline{R/W}$, \overline{DS}
(2)	Siemens/Intel non-multiplexed	V _{SS}	\overline{CS} , \overline{WR} , \overline{RD}
(3)	Siemens/Intel multiplexed	Edge	\overline{CS} , \overline{WR} , \overline{RD} , ALE

The occurrence of an edge on ALE, either positive or negative, at any time during the operation immediately selects the interface type (3). A return to one of the other interface types is possible only if a hardware reset is issued.

Note: If the multiplexed address/data bus type (3) is selected, the unused address pins A0-A7 must be tied to V_{DD}.

A read/write access to the ISAC-SX registers can be done in **multiplexed or non-multiplexed** mode:

- In non-multiplexed mode the register address must be applied to the address bus (A0-A7) for the data access via the data bus (AD0-AD7).
- In multiplexed mode the address on the address/data bus (AD0-AD7) is latched in by ALE before a data read/write access via the same bus is performed.

The ISAC-SX provides two different ways to address the register contents which is selected with the AMOD pin ('0' = direct mode, '1' = indirect mode). [Figure 7](#) illustrates both register addressing modes.

Direct address mode (AMOD = '0'): The register address to be read or written is directly set in the way described above.

Indirect address mode (AMOD = '1'): Only the LSB of the address is used to select either the address register (A0 = '0') or the data register (A0 = '1'). The microcontroller writes the register address to the ADDRESS register before it reads/writes data from/to the corresponding DATA register.

In indirect address mode the ISAC-SX evaluates no address line except the least significant address bit. The remaining address lines must not be left open but have to be tied to logical '1'.

Description of Functional Blocks

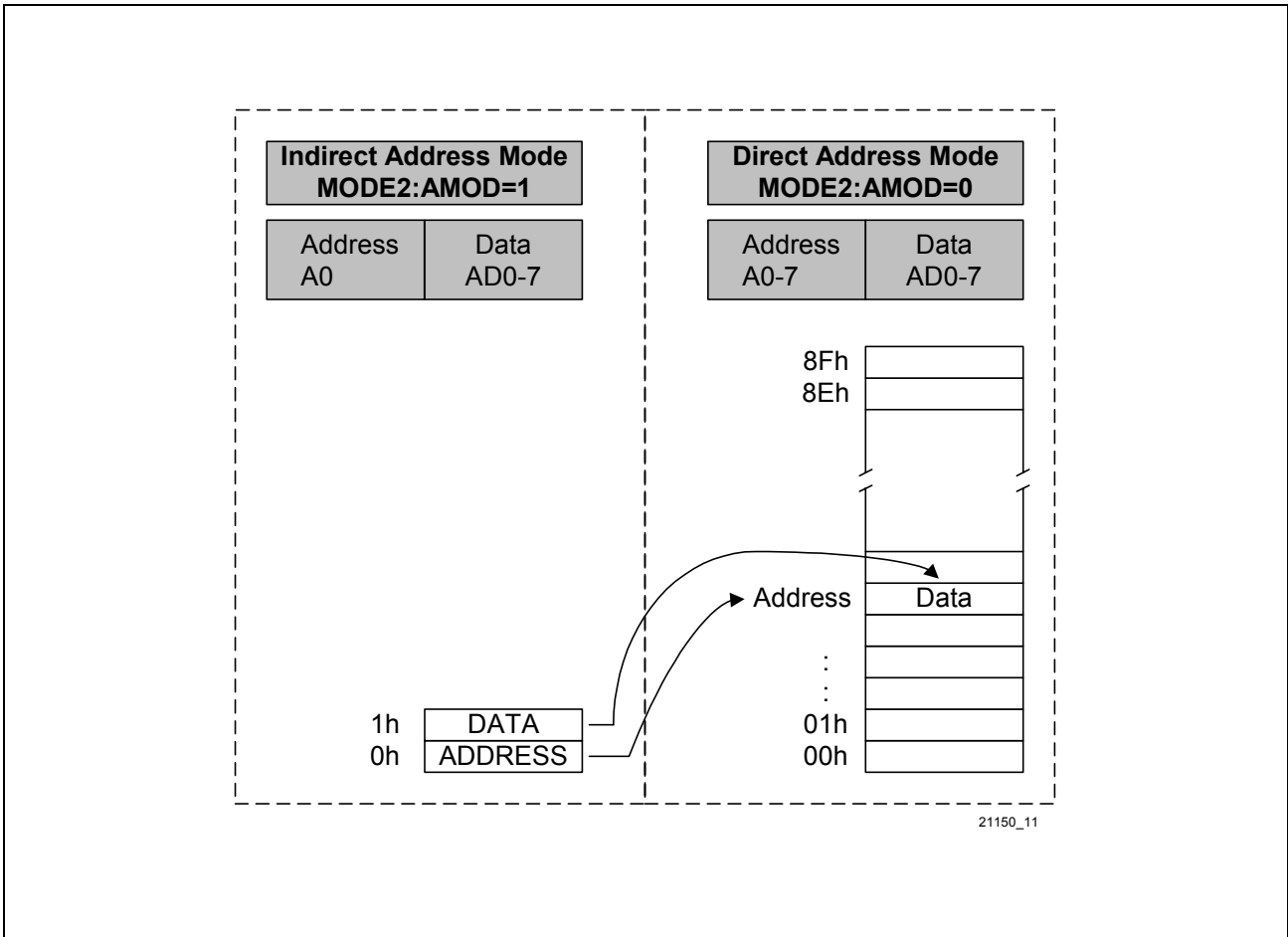

Figure 7 Direct/Indirect Register Address Mode

3.2.3 Interrupt Structure

Special events in the device are indicated by means of a single interrupt output, which requests the host to read status information from the device or transfer data from/to the device.

Since only one interrupt request pin ($\overline{\text{INT}}$) is provided, the cause of an interrupt must be determined by the host reading the interrupt status registers of the device.

The structure of the interrupt status registers is shown in **Figure 8**.

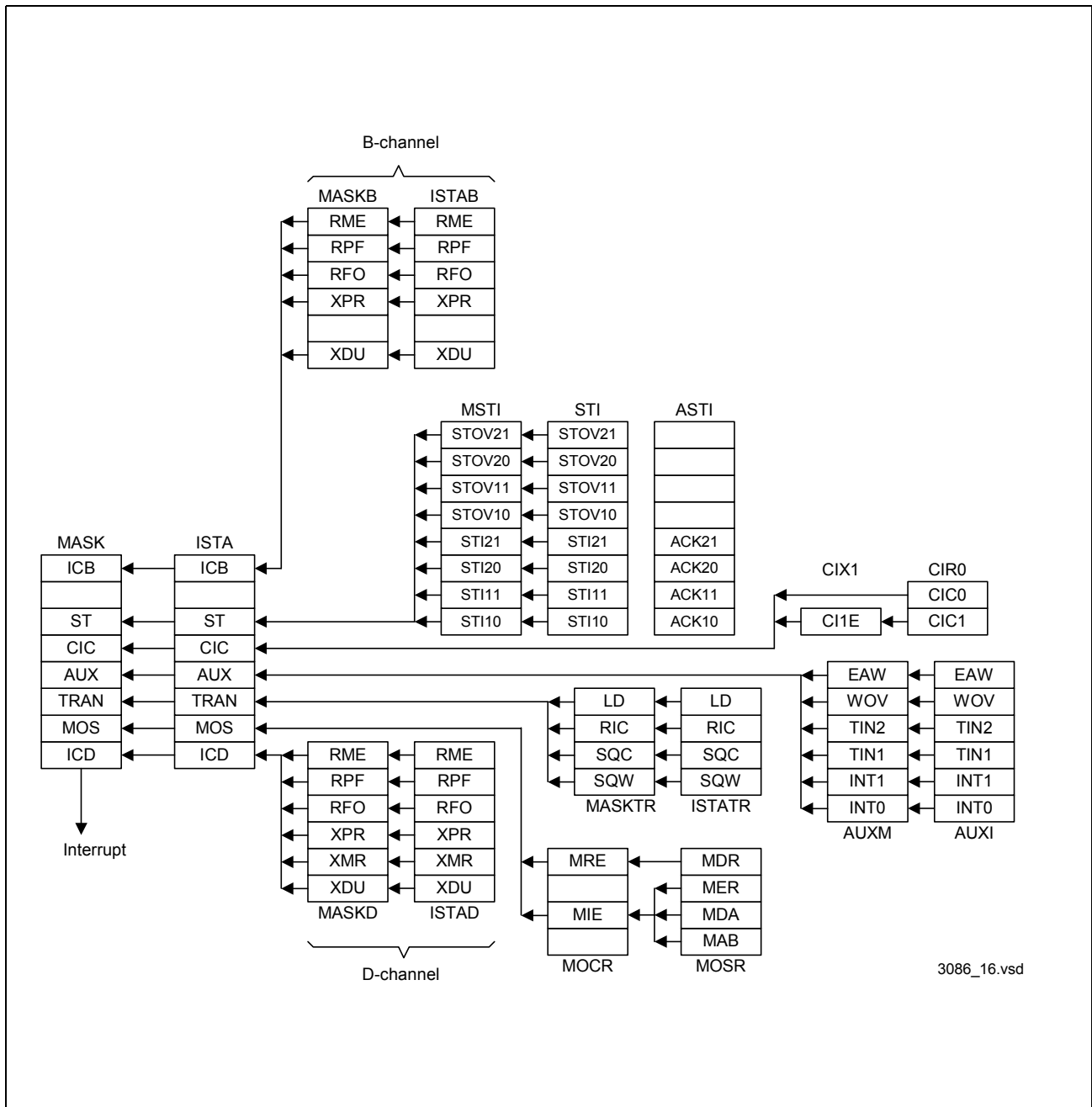

3086_16.vsd

Figure 8 Interrupt Status and Mask Registers

Description of Functional Blocks

All seven interrupt bits in the ISTA register point at interrupt sources in the D-channel HDLC Controller (ICD), B-channel HDLC controller (ICB), Monitor- (MOS) and C/I- (CIC) handler, the transceiver (TRAN), the synchronous transfer (ST) and the auxiliary interrupts (AUXI).

All these interrupt sources are described in the corresponding chapters. After the device has requested an interrupt activating the interrupt pin (\overline{INT}), the host must read first the device interrupt status register (ISTA) in the associated interrupt service routine. The interrupt pin of the device remains active until all interrupt sources are cleared by reading the corresponding interrupt register. Therefore it is possible that the interrupt pin is still active when the interrupt service routine is finished.

Each interrupt indication of the interrupt status registers can selectively be masked by setting the respective bit in the MASK register.

For some interrupt controllers or hosts it might be necessary to generate a new edge on the interrupt line to recognize pending interrupts. This can be done by masking all interrupts at the end of the interrupt service routine (writing FF_H into the MASK register) and write back the old mask to the MASK register.

3.2.4 Reset Generation

Figure 9 shows the organization of the reset generation of the device.

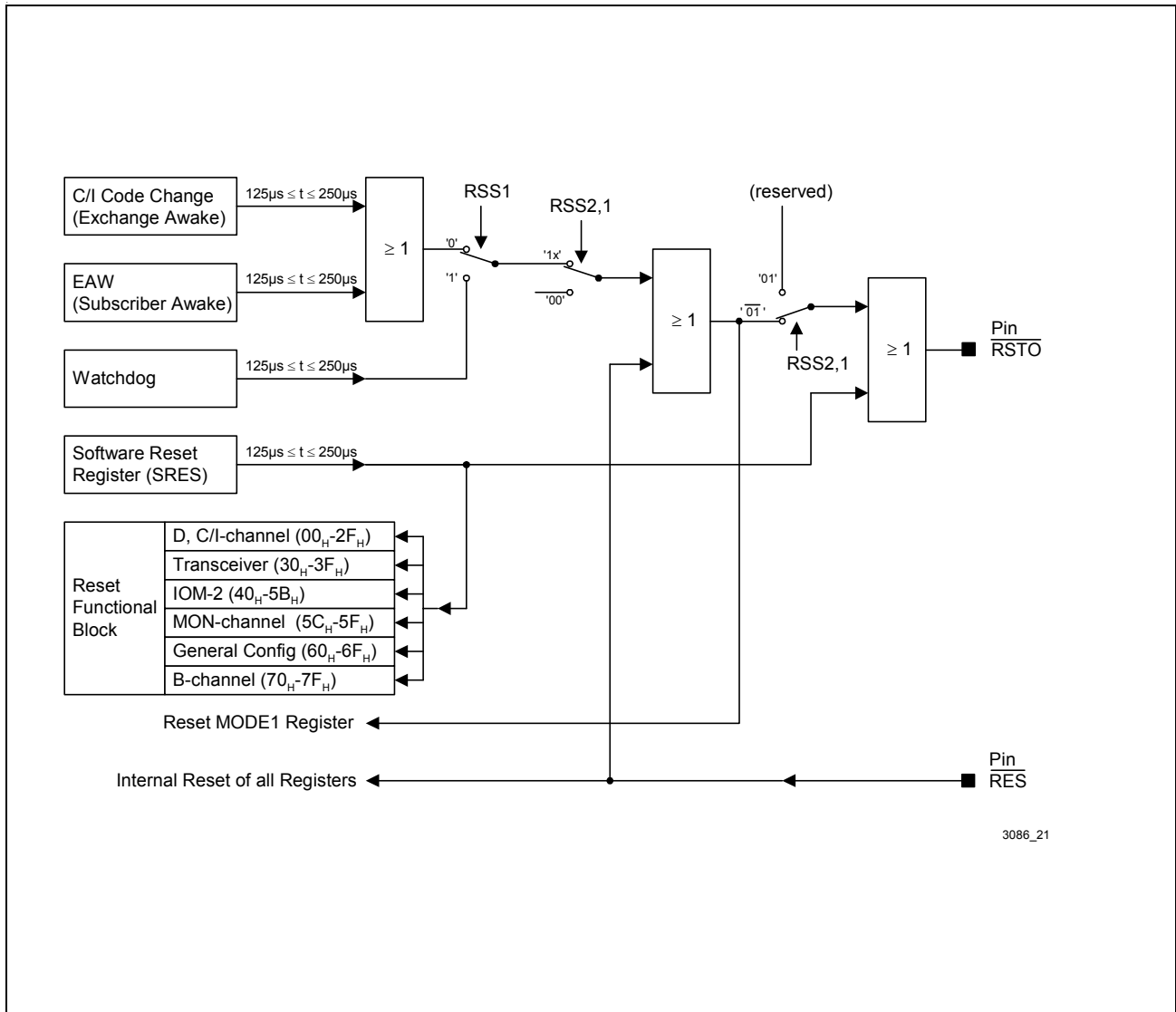

Figure 9 Reset Generation

Reset Source Selection

The internal reset sources C/I code change, \overline{EAW} and Watchdog can be output at the low active reset pin \overline{RSTO} . The selection of these reset sources can be done with the RSS2,1 bits in the MODE1 register according [Table 6](#).

The setting RSS2,1 = '01' is reserved for further use. In this case no reset except software reset (SRES.RSTO) is output on \overline{RSTO} . The internal reset sources set the MODE1 register to its reset value.

Description of Functional Blocks

Table 6 Reset Source Selection

RSS2 Bit 1	RSS1 Bit 0	C/I Code Change	EAW	Watchdog Timer
0	0	--	--	--
0	1	reserved		
1	0	x	x	--
1	1	--	--	x

- **C/I Code Change (Exchange Awake)**

A change in the downstream C/I channel (C/I0) generates an external reset pulse of $125 \mu\text{s} \leq t \leq 250 \mu\text{s}$.

- **EAW (Subscriber Awake)**

A low level on the $\overline{\text{EAW}}$ input starts the oscillator from the power down state and generates a reset pulse of $125 \mu\text{s} \leq t \leq 250 \mu\text{s}$.

- **Watchdog Timer**

After the selection of the watchdog timer (RSS = '11') an internal timer is reset and started. During every time period of 128 ms the microcontroller has to program the WTC1- and WTC2 bits in the following sequence to reset and restart the watchdog timer:

	WTC1	WTC2
1.	1	0
2.	0	1

If not, the timer expires and a WOV-interrupt (ISTA Register) together with a reset pulse of $125 \mu\text{s}$ is generated.

Deactivation of the watchdog timer is only possible with a hardware reset.

External Reset Input

At the $\overline{\text{RES}}$ input an external reset can be applied forcing the device in the reset state. This external reset signal is additionally fed to the $\overline{\text{RSTO}}$ output. The length of the reset signal is specified in [Chapter 5.9](#).

After an external reset from the $\overline{\text{RES}}$ pin all registers of the device are set to its reset values (see register description in [Chapter 4](#)).

Software Reset Register (SRES)

Every main functional block of the device can be reset separately by software setting the corresponding bit in the SRES register. A reset to external devices can also be controlled in this way. The reset state is activated by setting the corresponding bit to '1' and onchip

Description of Functional Blocks

logic resets this bit again automatically after 4 BCL clock cycles. The address range of the registers which will be reset at each SRES bit is listed in [Figure 9](#).

3.2.5 Timer Modes

The ISAC-SX provides two timers which can be used for various purposes. Each of them provides two modes ([Table 7](#)), a count down timer interrupt, i.e. an interrupt is generated only once after expiration of the selected period, and a periodic timer interrupt, which means an interrupt is generated continuously after every expiration of that period.

Table 7 ISAC-SX Timers

Address	Register	Modes	Period
24 _H	TIMR1	Periodic	64 ... 2048 ms
		Count Down	64 ms ... 14.336 s
65 _H	TIMR2	Periodic	1 ... 63 ms
		Count Down	1 ... 63 ms

When the programmed period has expired an interrupt is generated and indicated in the auxiliary interrupt status ISTA.AUX. The source of the interrupt can be read from AUXI (TIN1, TIN2) and each of the interrupt sources can be masked in AUXM.

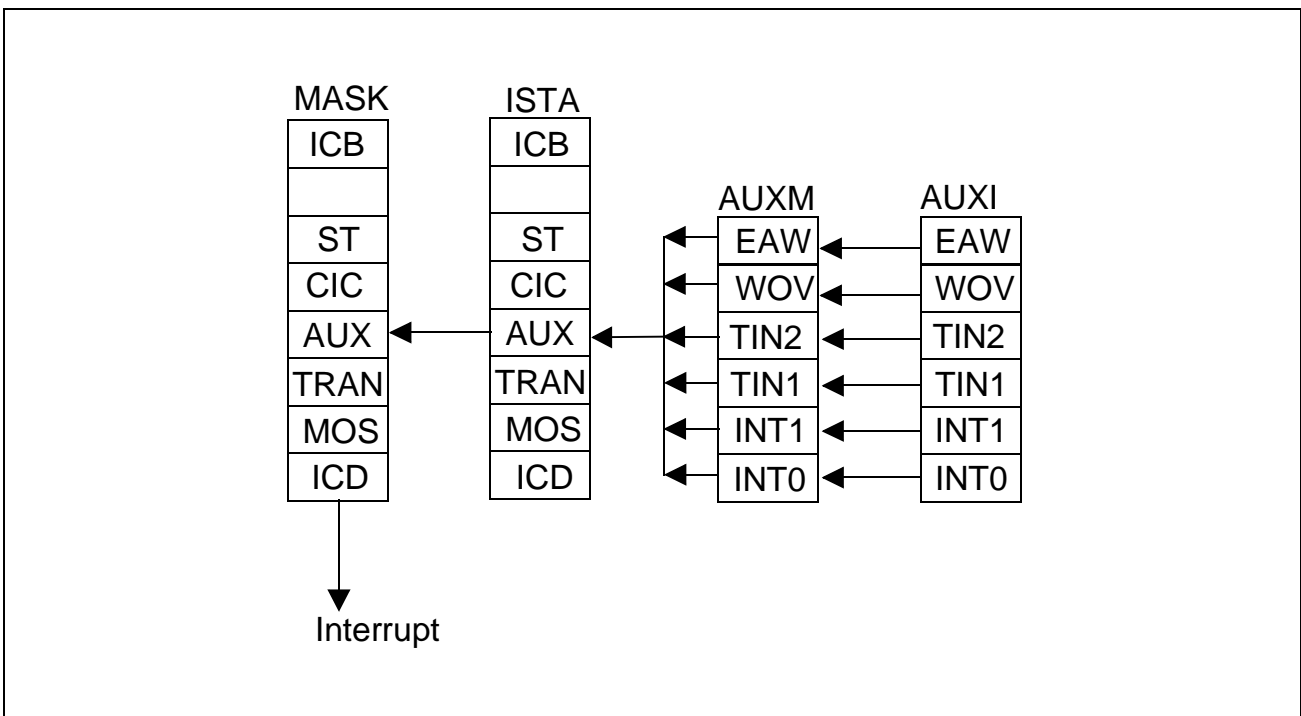

Figure 10 Timer Interrupt Status Registers

Timer 1

The host controls the timer 1 by setting bit CMDRD.STI to start the timer and by writing register TIMR1 to stop the timer. After time period T1 an interrupt (AUXI.TIN1) is generated continuously if CNT=7 or a single interrupt is generated after timer period T if CNT<7 (**Figure 11**).

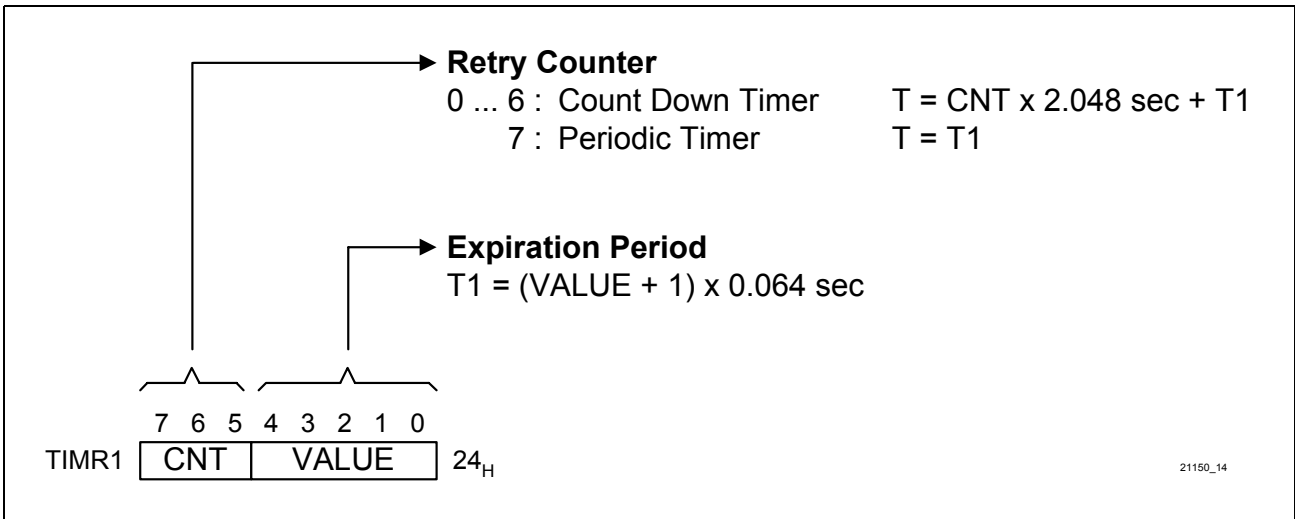

Figure 11 Timer 1 Register

Timer 2

The host starts and stops timer 2 in TIMR2.CNT (**Figure 12**). If TIMR2.TMD=0 the timer is operating in count down mode, for TIMR2.TMD=1 a periodic interrupt AUXI.TIN2 is generated. The timer length (for count down timer) or the timer period (for periodic timer), respectively, can be configured to a value between 1 - 63 ms (TIMR2.CNT).

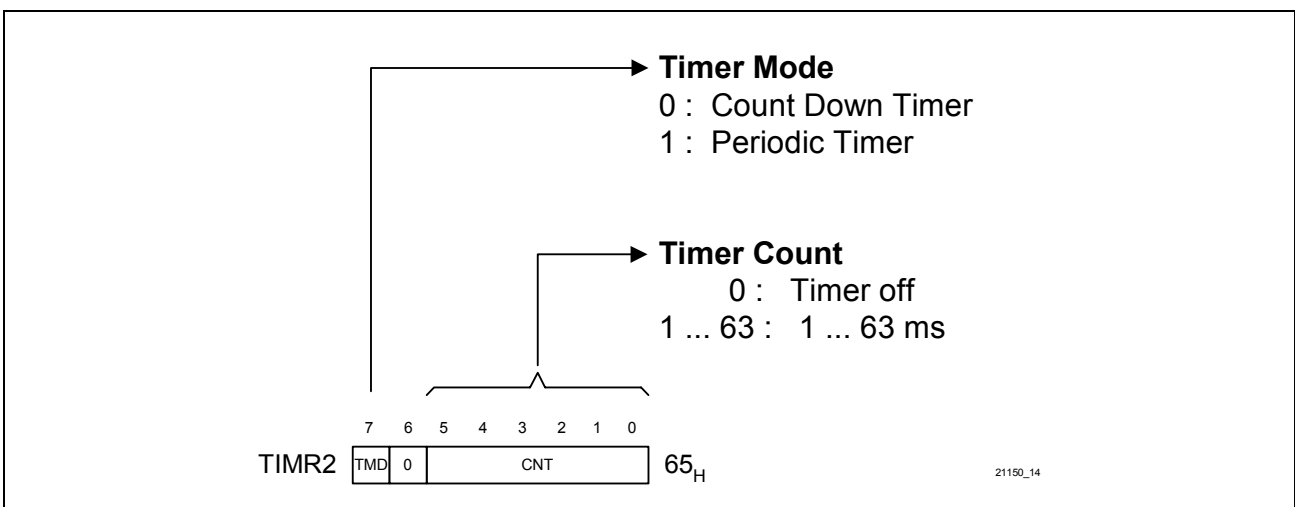

Figure 12 Timer 2 Register

3.2.6 Activation Indication via Pin \overline{ACL}

The activated state of the S-interface is directly indicated via pin \overline{ACL} (Activation LED). An LED with pre-resistance may directly be connected to this pin and a low level is driven on \overline{ACL} as soon as the layer 1 state machine reaches the activated state (see [Figure 13](#)).

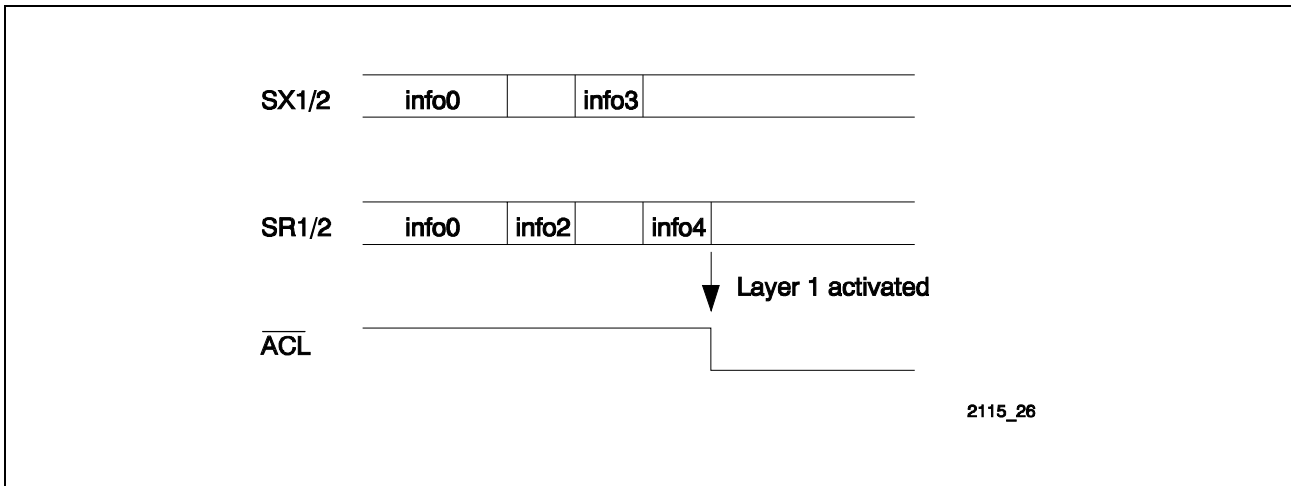

Figure 13 \overline{ACL} Indication of Activated Layer 1

By default ($ACFG2.ACL=0$) the state of layer 1 is indicated at pin \overline{ACL} . If the automatic indication of the activated layer 1 is not required, the state on pin \overline{ACL} can also be controlled by the host (see [Figure 14](#)).

If $ACFG2.ACL=1$ the LED on pin \overline{ACL} can be switched on ($ACFG2.LED=1$) and off ($ACFG2.LED=0$) by the host.

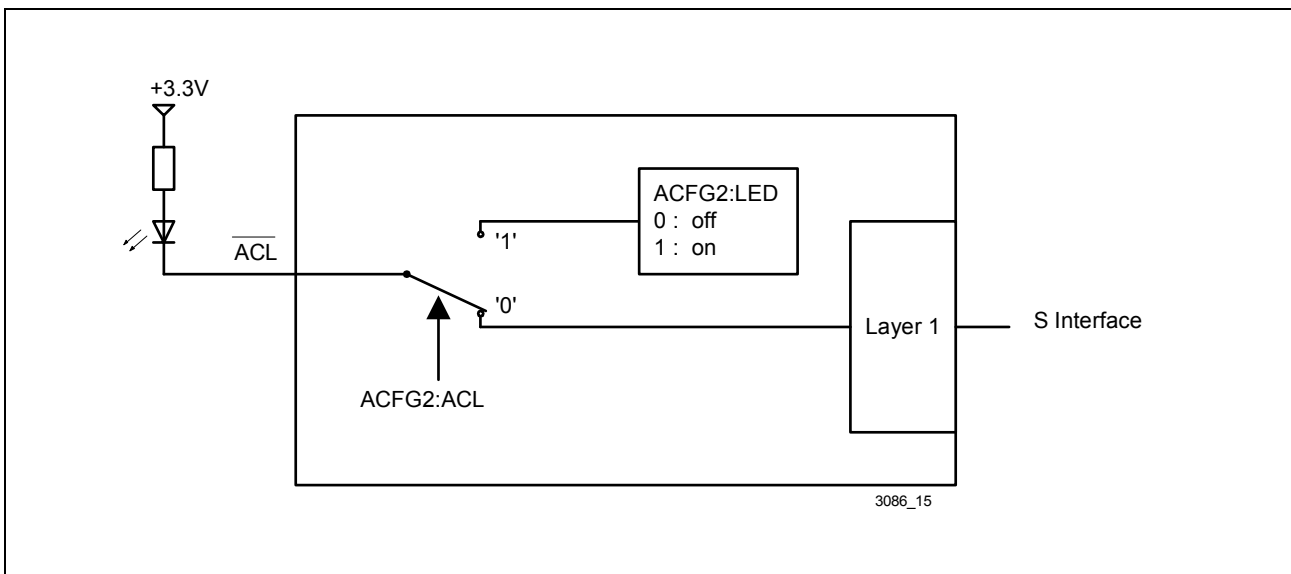

Figure 14 \overline{ACL} Configuration

3.3 S/T-Interface

The layer-1 functions for the S/T interface of the ISAC-SX are:

- line transceiver functions for the S/T interface according to the electrical specifications of ITU-T I.430;
- conversion of the frame structure between IOM-2 and S/T interface;
- conversion from/to binary to/from pseudo-ternary code;
- level detection
- receive timing recovery for point-to-point, passive bus and extended passive bus configuration
- S/T timing generation using IOM-2 timing synchronous to system, or vice versa;
- D-channel access control and priority handling;
- D-channel echo bit generation by handling of the global echo bit;
- activation/deactivation procedures, triggered by primitives received over the IOM-2 C/I channel or by INFO's received from the line;
- execution of test loops.

The wiring configurations in user premises, in which the ISAC-SX can be used, are illustrated in [Figure 15](#).

Description of Functional Blocks

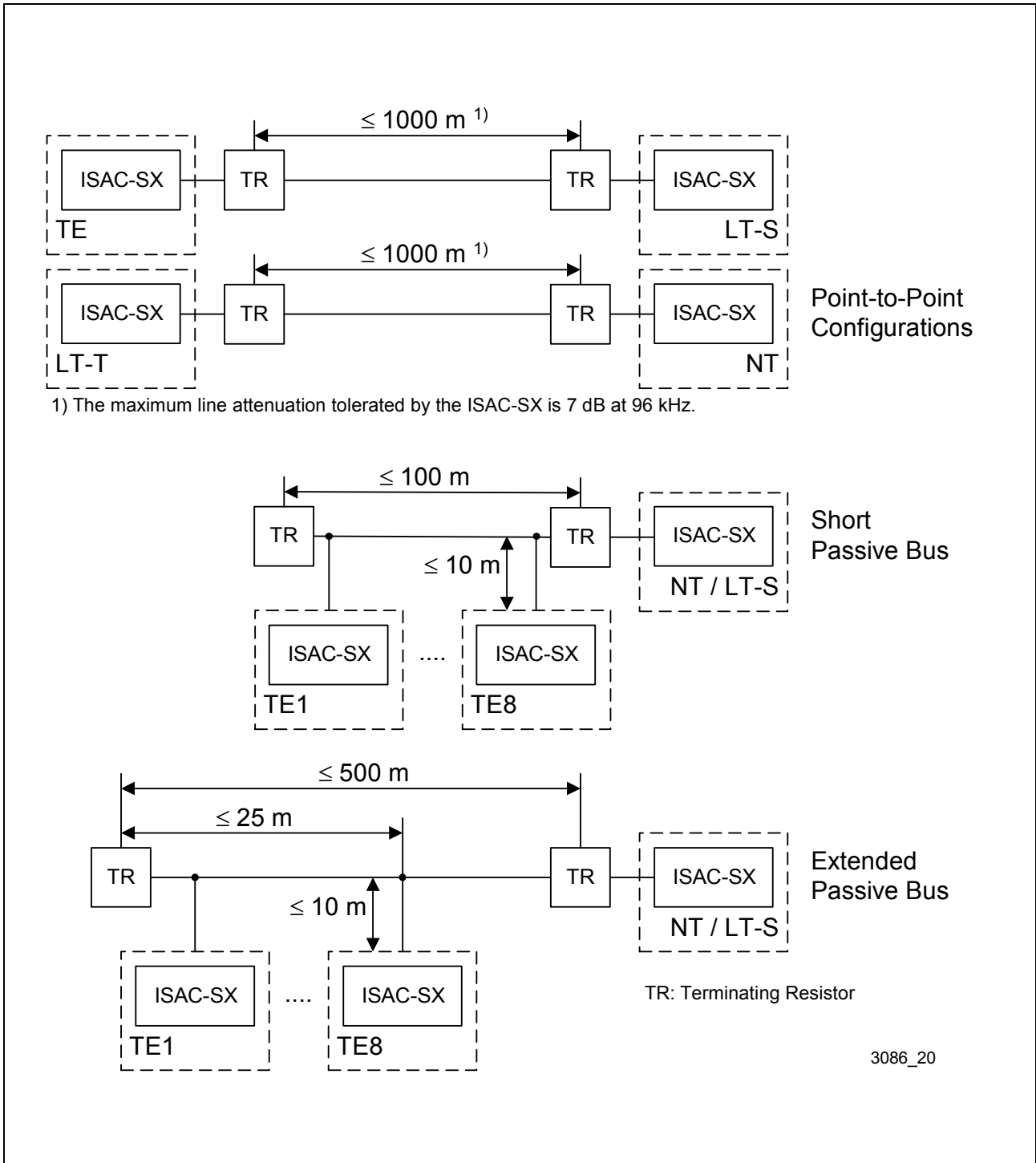

Figure 15 Wiring Configurations in User Premises

3.3.1 S/T-Interface Coding

Transmission over the S/T-interface is performed at a rate of 192 kbit/s. 144 kbit/s are used for user data (B1+B2+D), 48 kbit/s are used for framing and maintenance information.

Line Coding

The following figure illustrates the line code. A binary ONE is represented by no line signal. Binary ZEROs are coded with alternating positive and negative pulses with two exceptions:

For the required frame structure a code violation is indicated by two consecutive pulses of the same polarity. These two pulses can be adjacent or separated by binary ONES. In bus configurations a binary ZERO always overwrites a binary ONE.

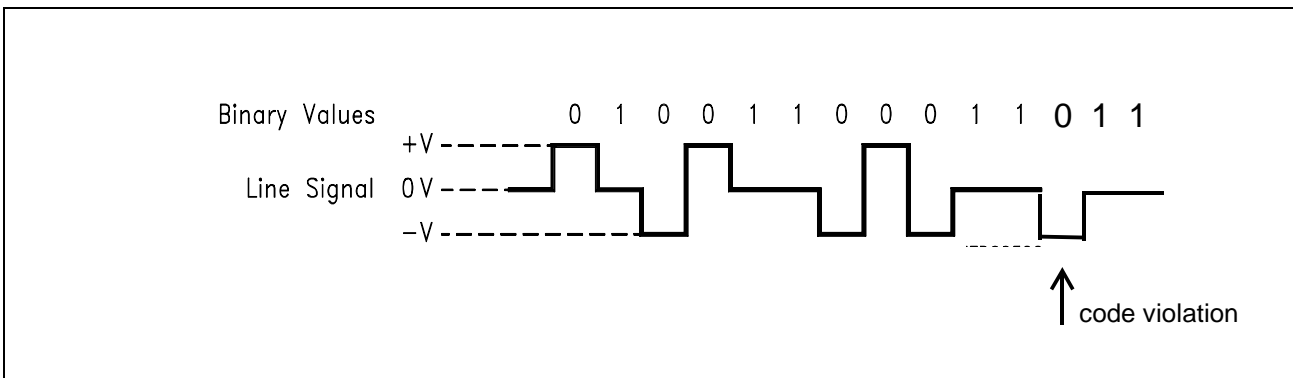

Figure 16 S/T -Interface Line Code

Frame Structure

Each S/T frame consists of 48 bits at a nominal bit rate of 192 kbit/s. For user data (B1+B2+D) the frame structure applies to a data rate of 144 kbit/s (see [Figure 17](#)).

In the direction TE → NT the frame is transmitted with a two bit offset. For details on the framing rules please refer to ITU I.430 section 6.3. The following figure illustrates the standard frame structure for both directions (NT → TE and TE → NT) with all framing and maintenance bits.

Description of Functional Blocks

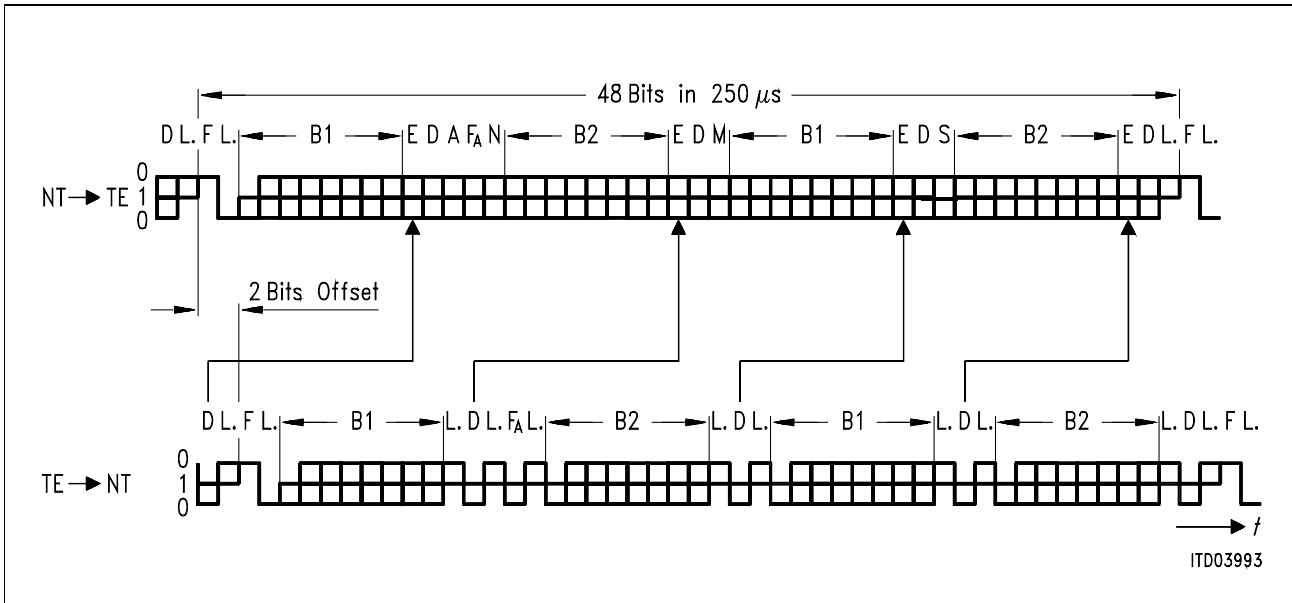

Figure 17 Frame Structure at Reference Points S and T (ITU I.430)

- F Framing Bit F = (0b) → identifies new frame (always positive pulse, always code violation)
- L. D.C. Balancing Bit L. = (0b) → number of binary ZEROs sent after the last L. bit was odd
- D D-Channel Data Bit Signaling data specified by user
- E D-Channel Echo Bit E = D → received E-bit is equal to transmitted D-bit
- F_A Auxiliary Framing Bit See section 6.3 in ITU I.430
- N N = $\overline{F_A}$
- B1 B1-Channel Data Bit User data
- B2 B2-Channel Data Bit User data
- A Activation Bit A = (0b) → INFO 2 transmitted
A = (1b) → INFO 4 transmitted
- S S-Channel Data Bit S₁ channel data (see note below)
- M Multiframe Bit M = (1b) → Start of new multiframe

Note: The ITU I.430 standard specifies S1 - S5 for optional use.

Description of Functional Blocks

3.3.2 S/T-Interface Multiframe

According to ITU recommendation I.430 a multiframe provides extra layer 1 capacity in the TE-to-NT direction by using an extra channel between the TE and NT (Q-channel). The Q bits are defined to be the bits in the F_A bit position.

In the NT-to-TE direction the S-channel bits are used for information transmission. One S channel (S1) out of five possible S-channels can be accessed by the ISAC-SX.

In the NT-to-TE direction the S-channel bits are used for information transmission.

The S and Q channels are accessed via the μC interface or the IOM-2 MONITOR channel, respectively, by reading/writing the SQR or SQX bits in the S/Q channel registers (SQRRx, SQXRx).

Table 8 shows the S and Q bit positions within the multiframe.

Table 8 S/Q-Bit Position Identification and Multiframe Structure

Frame Number	NT-to-TE F_A Bit Position	NT-to-TE M Bit	NT-to-TE S Bit	TE-to-NT F_A Bit Position
1	ONE	ONE	S11	Q1
2	ZERO	ZERO	S21	ZERO
3	ZERO	ZERO	S31	ZERO
4	ZERO	ZERO	S41	ZERO
5	ZERO	ZERO	S51	ZERO
6	ONE	ZERO	S12	Q2
7	ZERO	ZERO	S22	ZERO
8	ZERO	ZERO	S32	ZERO
9	ZERO	ZERO	S42	ZERO
10	ZERO	ZERO	S52	ZERO
11	ONE	ZERO	S13	Q3
12	ZERO	ZERO	S23	ZERO
13	ZERO	ZERO	S33	ZERO
14	ZERO	ZERO	S43	ZERO
15	ZERO	ZERO	S53	ZERO
16	ONE	ZERO	S14	Q4
17	ZERO	ZERO	S24	ZERO
18	ZERO	ZERO	S34	ZERO
19	ZERO	ZERO	S44	ZERO
20	ZERO	ZERO	S54	ZERO
1	ONE	ONE	S11	Q1
2	ZERO	ZERO	S21	ZERO

Description of Functional Blocks**TE Mode**

After multiframe synchronization has been established, the Q data will be inserted at the upstream (TE → NT) F_A bit position in each 5th S/T frame (see [Table 8](#)).

When synchronization is not achieved or lost, each received F_A bit is mirrored to the next transmitted F_A bit.

Multiframe synchronization is achieved after two complete multiframes have been detected with reference to F_A/N bit and M bit positions. Multiframe synchronization is lost if bit errors in F_A/N bit or M bit positions have been detected in two consecutive multiframes. The synchronization state is indicated by the MSYN bit in the S/Q-channel receive register (SQRR1).

The multiframe synchronization can be enabled or disabled by programming the MFEN bit in the S/Q-channel transmit register (SQXR1).

NT Mode

The transceiver in NT mode starts multiframing if SQXR1.MFEN is set.

After multiframe synchronization has been established in the TE, the Q data will be inserted at the upstream (TE → NT) F_A bit position by the TE in each 5th S/T frame, the S data will be inserted at the downstream (NT → TE) S bit position in each S/T frame (see [Table 8](#)).

Interrupt Handling for Multiframing

To trigger the microcontroller for a multiframe access an interrupt can be generated once per multiframe (SQW) or if the received S-channels (TE) or Q-channel (NT) have changed (SQC).

In both cases the microcontroller has access to the multiframe within the duration of one multiframe (5 ms).

3.3.3 Multiframe Synchronization (M-Bit)

The ISAC-SX offers the capability to control the start of the multiframe from external signals, so applications which require synchronization between different S-interfaces are possible. Such an application is the connection of DECT base stations to PBX line cards.

For this purpose a multiplexed function of the AUX4 pin is used. If the ACFG2.A4SEL is set to "1" the pin is not used as general purpose I/O pin but as M-bit input (NT, LT-S) or as M-Bit output (TE, LT-T). The direction input/output of the pin MBIT is automatically selected with the operation mode.

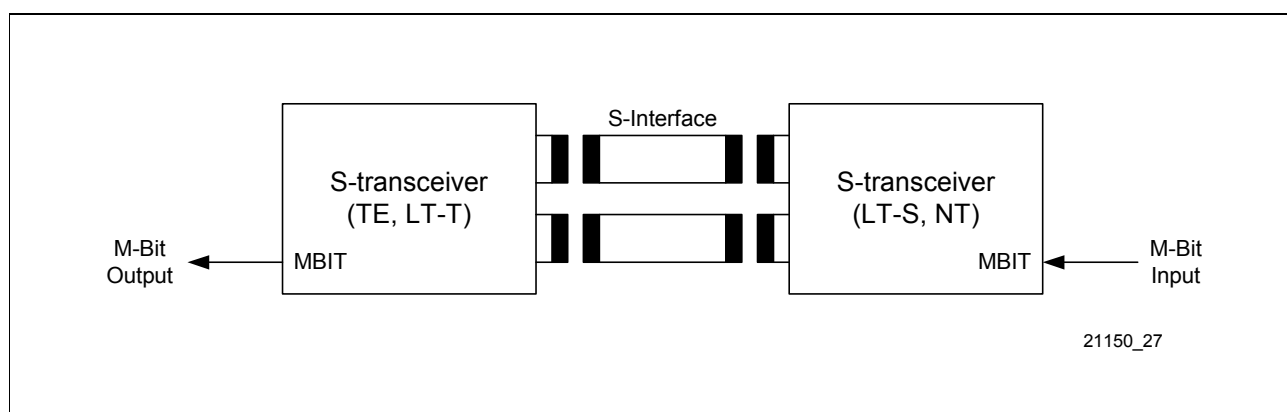

Figure 18 Multiframe Synchronization Using the M-Bit

M-Bit Input (LT-S, NT-Mode)

The MBIT pin can be used to synchronize the multiframe structure between several S-transceivers. Multiframe generation must be enabled (SQXR1.MFEN=1).

The value of MBIT is sampled at the start of the F-bit of the S-frame.

If the input on MBIT is "1", the multiframe counter is reset to frame no. 20 and as a result, the bits F_A , M and S are transmitted as logic ZERO (line = "1"). If MBIT becomes "0" again, the multiframe counter counts 20 frames (starting with frame no. 1) and begins again autonomously.

If MBIT is kept "1", the multiframe counter is permanently reset and the bits F_A , M and S stay at logic ZERO (line = "1"). If MBIT becomes "0" for only one S-frame, the multiframe-counter reaches frame no. 1 at which a logic ONE (line = "0") is transmitted in the F_A and M-bit position and the S11 bit is transmitted.

Thus, the M-bit can be used to transfer synchronization pulses of any length between different S-interfaces.

M-Bit Output (TE, LT-T Mode)

In TE and LT-T mode, the ISAC-SX outputs the value of the M-bit on the MBIT pin.

The value of M should be sampled at the falling edge of FSC.

Sample Time

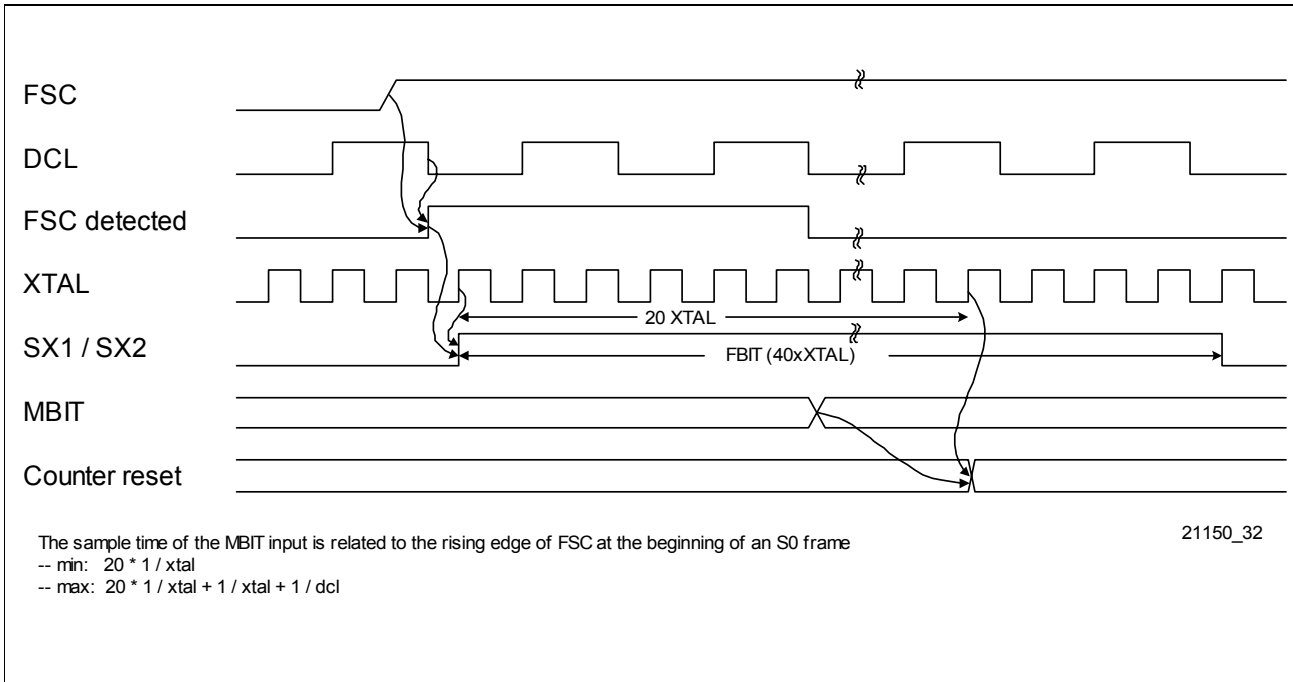

Figure 19 Sampling Time in LT-S / NT mode (M-Bit input)

Frame Relationship

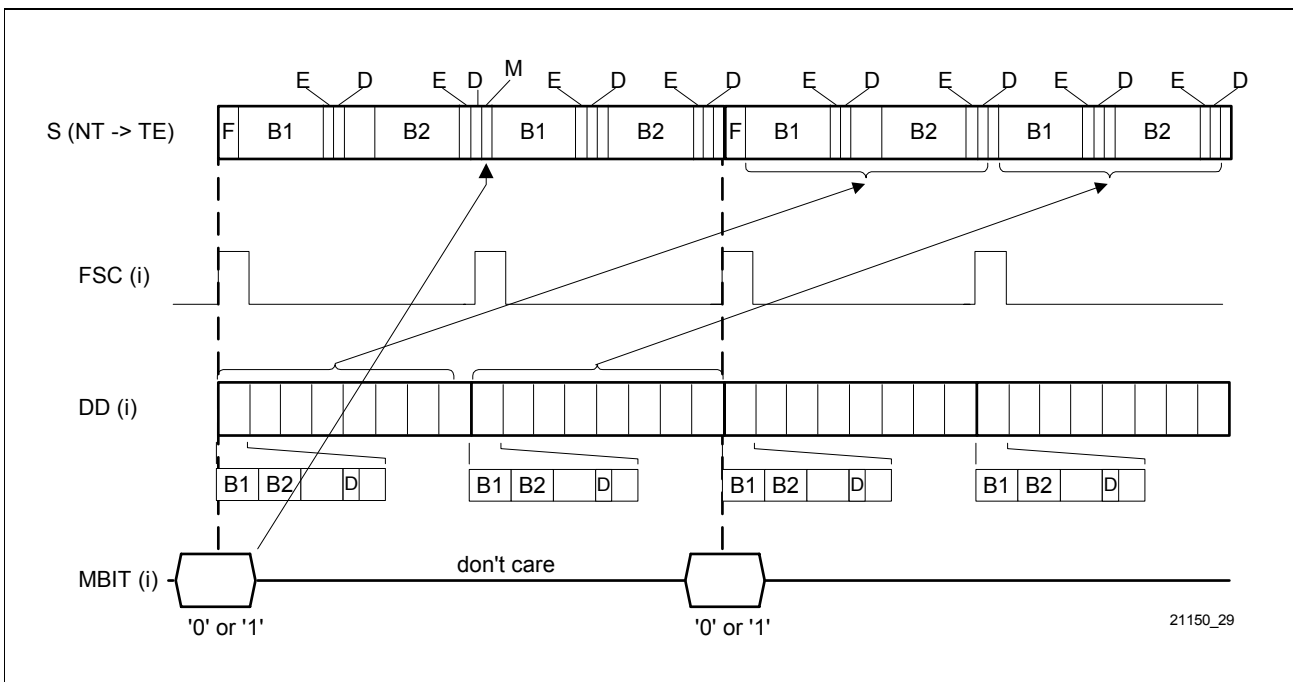

Figure 20 Frame Relationship in LT-S / NT mode (M-Bit input)

Description of Functional Blocks

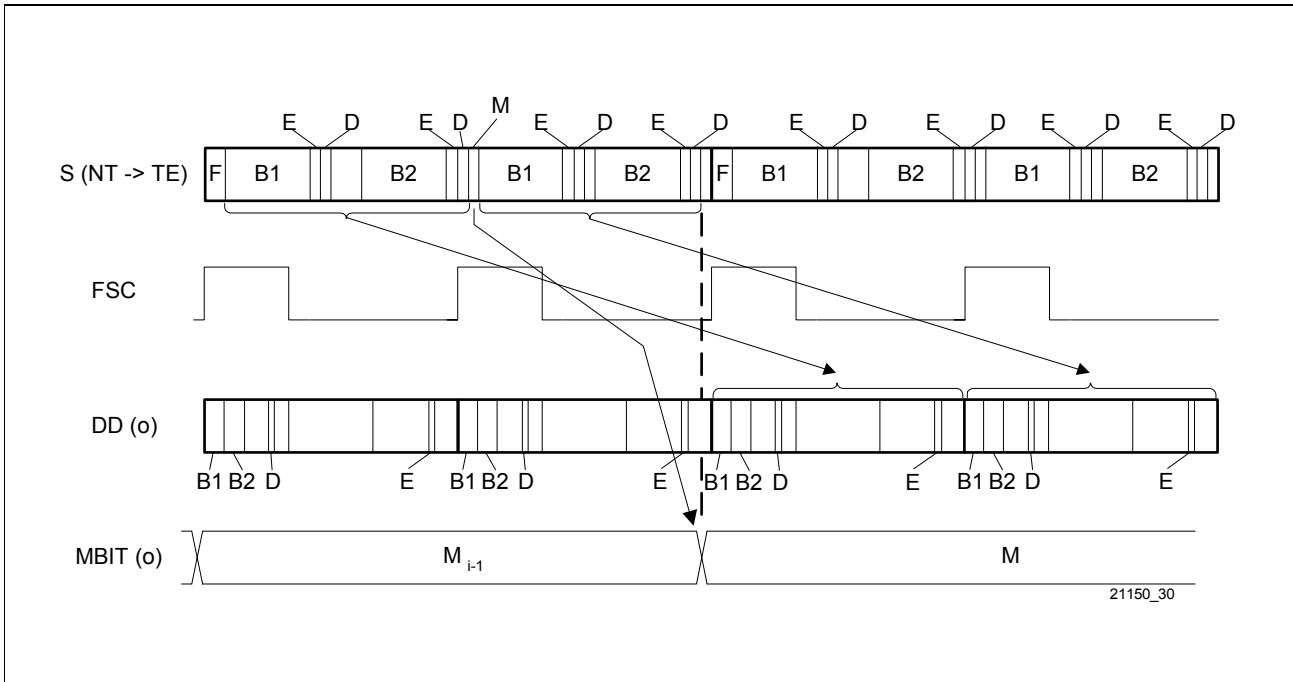

Figure 21 Frame Relationship in TE / LT-T mode (M-Bit output)

3.3.4 Data Transfer and Delay between IOM-2 and S/T

TE mode

In the state F7 (Activated) or if the internal layer-1 statemachine is disabled and XINF of register TR_CMD is programmed to '011' the B1, B2, D and E bits are transferred transparently from the S/T to the IOM-2 interface. In all other states '1's are transmitted to the IOM-2 interface.

To transfer data transparently to the S/T interface any activation request C/I command (AR8, AR10 or ARL) is additionally necessary or if the internal layer-1 statemachine is disabled, bit TDDIS of register TR_CMD has additionally to be programmed to '0'.

Figure 22 shows the data delay between the IOM-2 and the S/T interface and vice versa.

For the D channel the delay from the IOM-2 to the S/T interface is only valid if S/G evaluation is disabled (MODED.DIM0=0). If S/G evaluation is enabled (MODED.DIM2-0=0x1) the delay depends on the selected priority and the relation between the echo bits on S and the D channel bits on the IOM-2, e.g. for priority 8 the timing relation between the 8th D-bit on S bus and the D-channel on IOM-2.

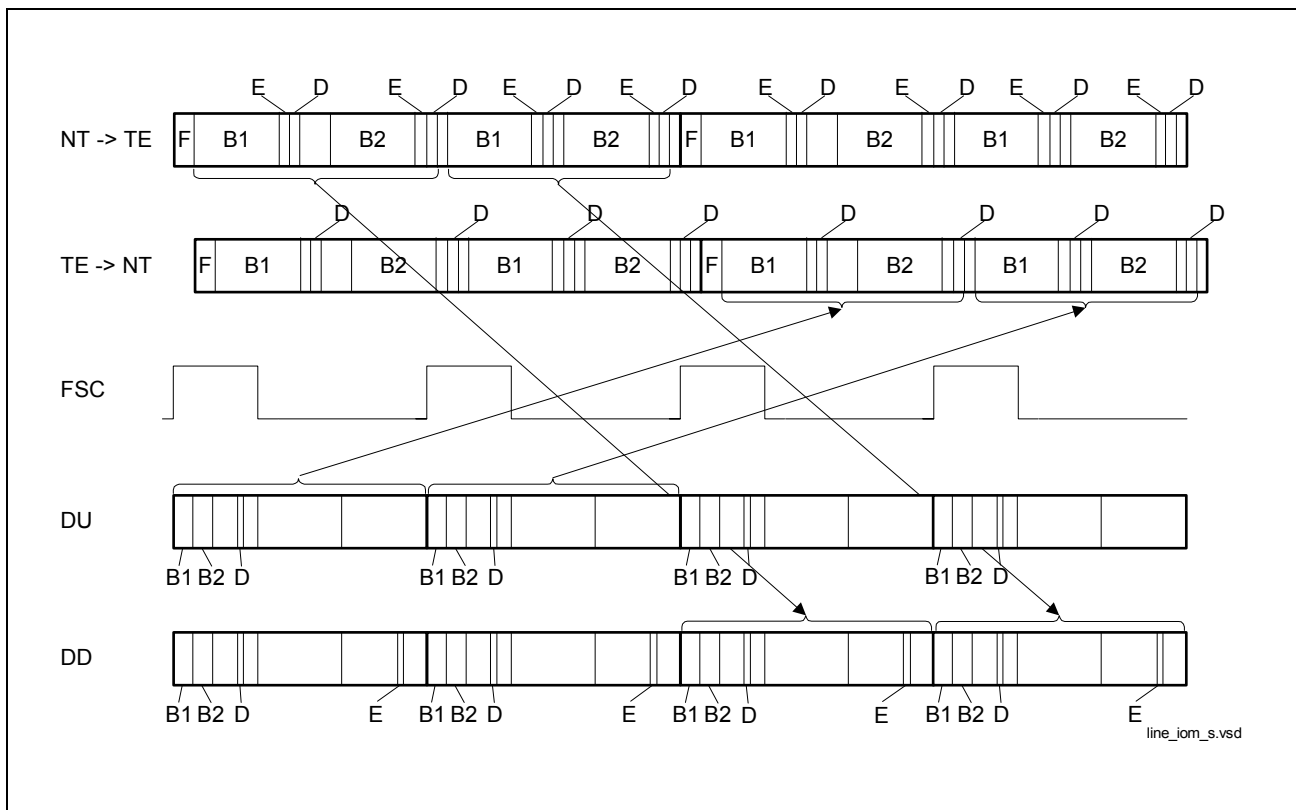

Figure 22 Data Delay between IOM-2 and S/T Interface (TE mode only)

Description of Functional Blocks

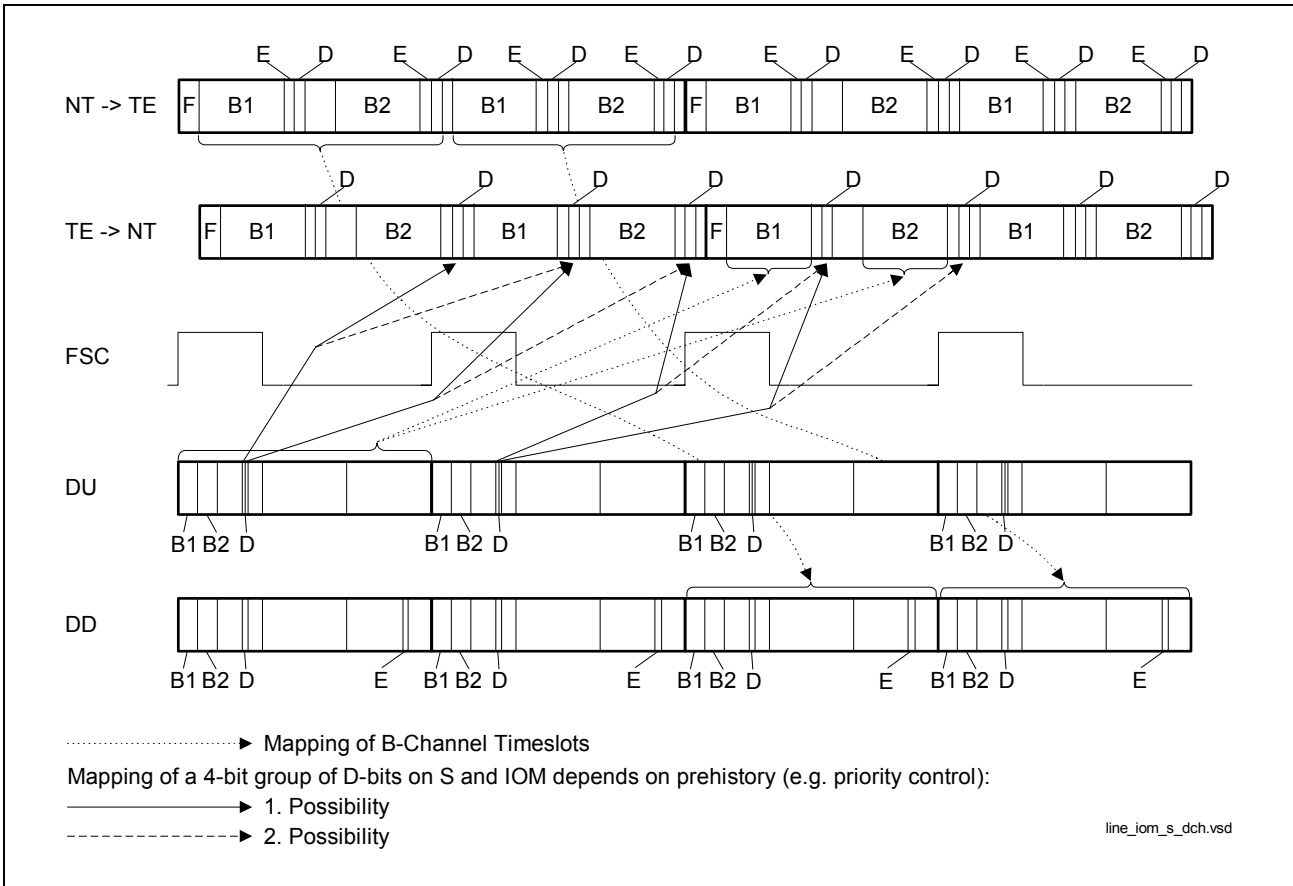

Figure 23 Data Delay between IOM-2 and S/T Interface with S/G Bit Evaluation (TE mode only)

LT-T mode

In this mode the frame relation between S/T interface and IOM-2 is flexible.

LT-S/NT mode

In the state F7 (Activated) or if the internal layer-1 statemachine is disabled and XINF of register TR_CMD is programmed to '011' the B1, B2 and D bits are transferred transparently from the S/T to the IOM-2 interface. In all other states '1's are transmitted to the IOM-2 interface.

Note: In intelligent NT the D-channel access can be blocked by the IOM-2 D-channel handler.

Description of Functional Blocks

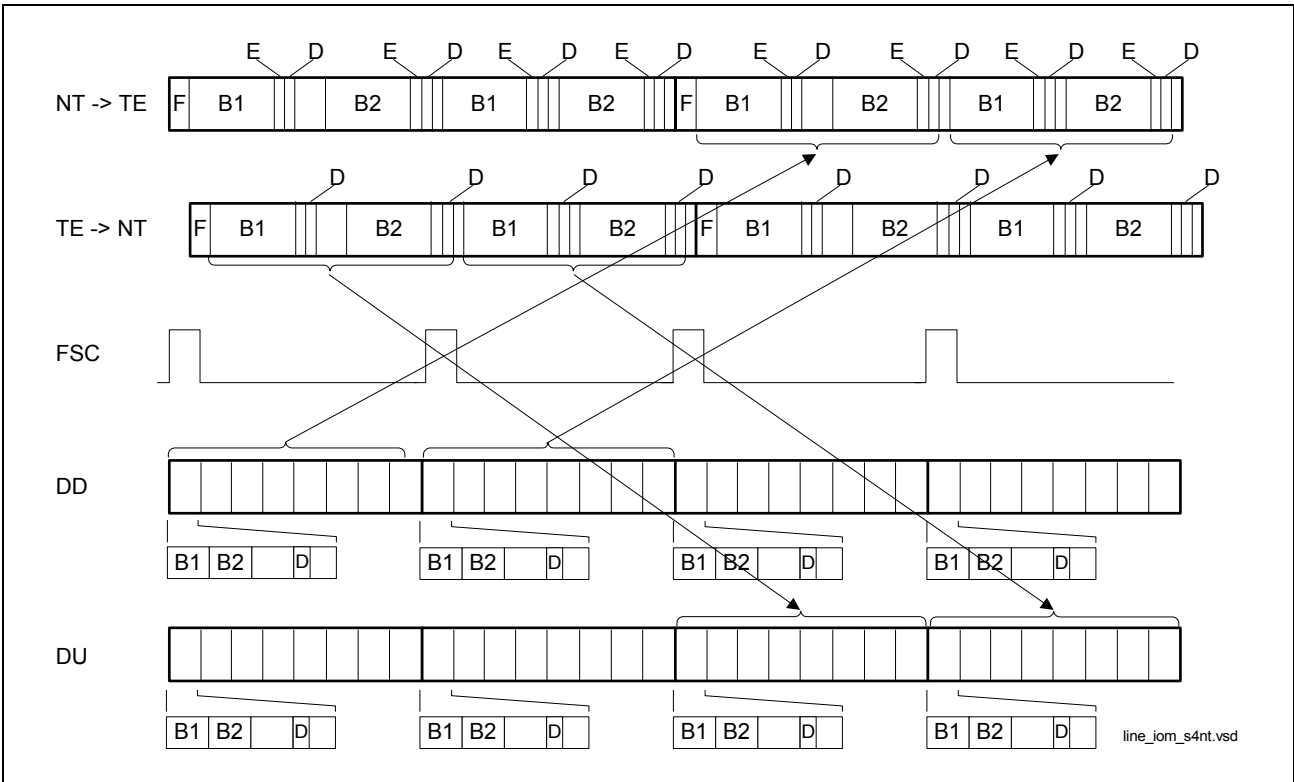

Figure 24 Data Delay between IOM-2 and S/T Interface with 8 IOM Channels (LT-S/NT mode only)

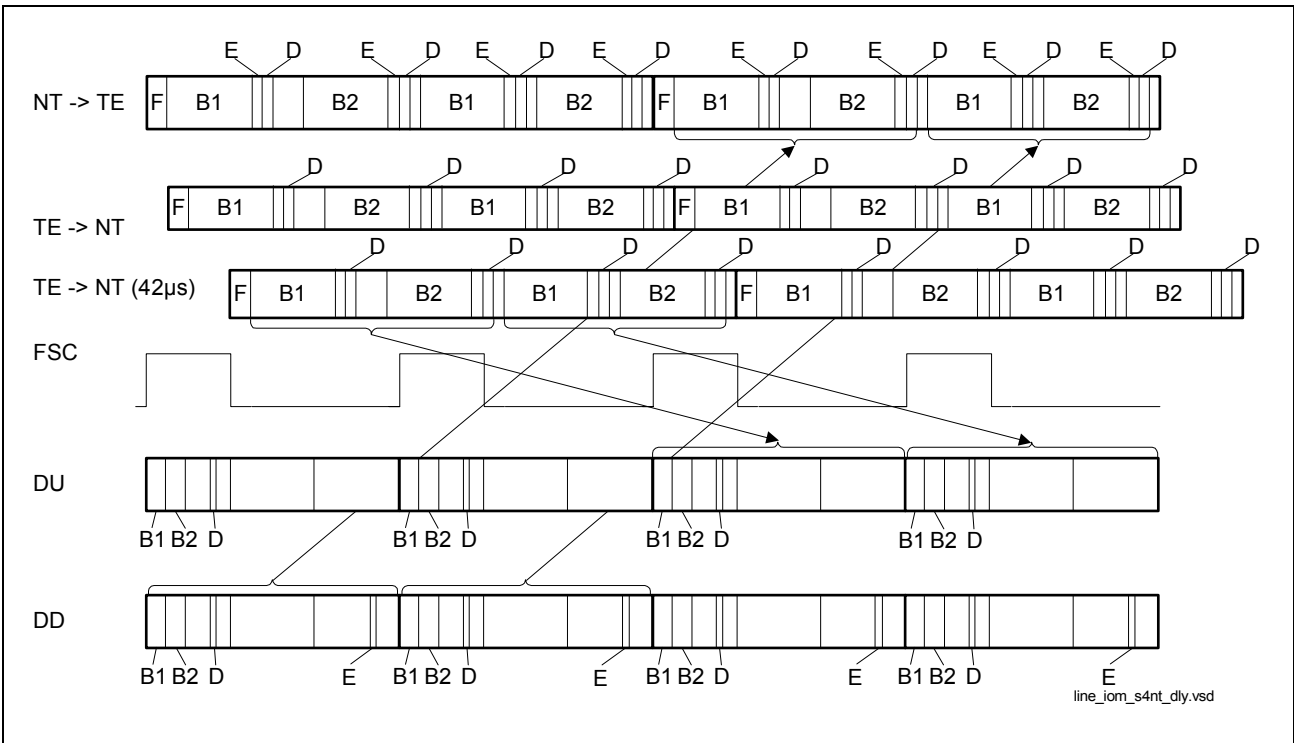

Figure 25 Data Delay between IOM-2 and S/T Interface with 3 IOM Channels and Maximum Receive Delay(LT-S/NT mode only)

3.3.5 Transmitter Characteristics

The full-bauded pseudo-ternary pulse shaping is achieved with the integrated transmitter which is realized as a symmetrical current limited voltage source ($V_{SX1/SX2} = +/-1.0\text{ V}$; $I_{\text{max}} = 26\text{ mA}$). The equivalent circuit of the transmitter is shown in **Figure 26**. The nominal pulse amplitude on the S-interface 750 mV (zero-peak) is adjusted with external resistors (see **Chapter 3.3.7.1**).

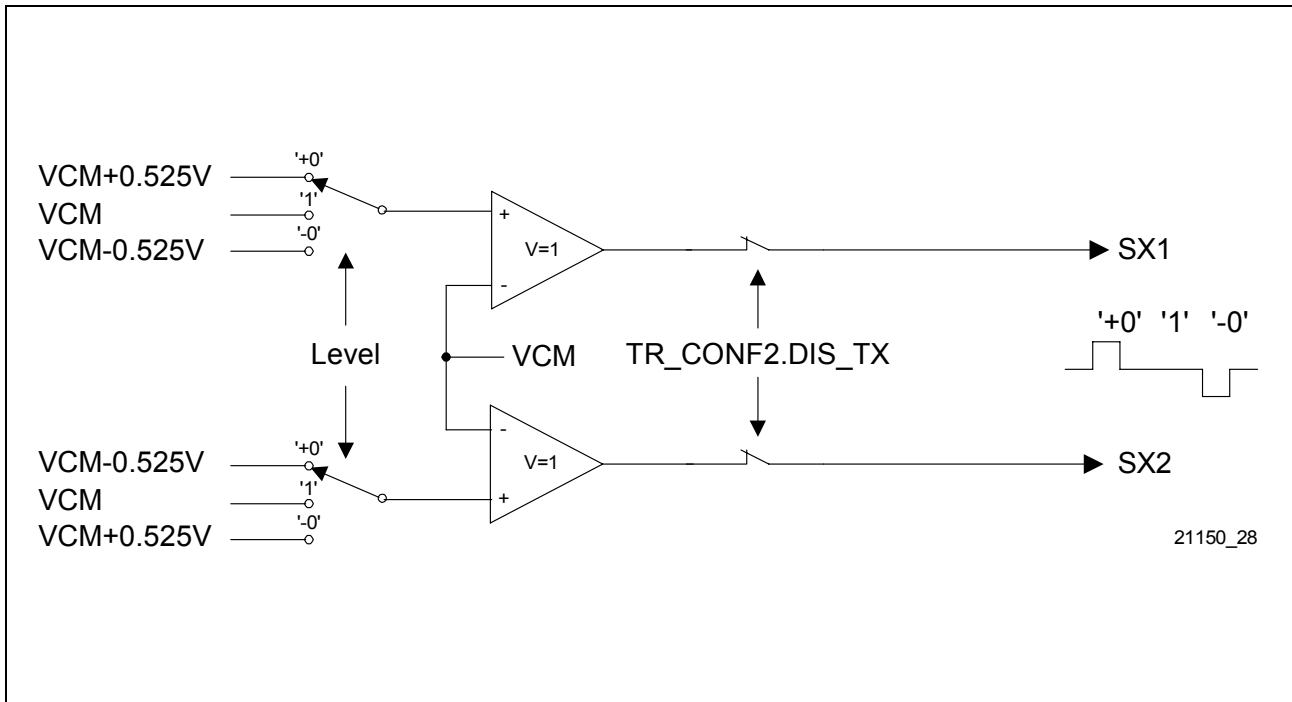

Figure 26 Equivalent Internal Circuit of the Transmitter Stage

3.3.6 Receiver Characteristics

The receiver consists of a differential input stage, a peak detector and a set of comparators. Additional noise immunity is achieved by digital oversampling after the comparators. A simplified equivalent circuit of the receiver is shown in [Figure 27](#).

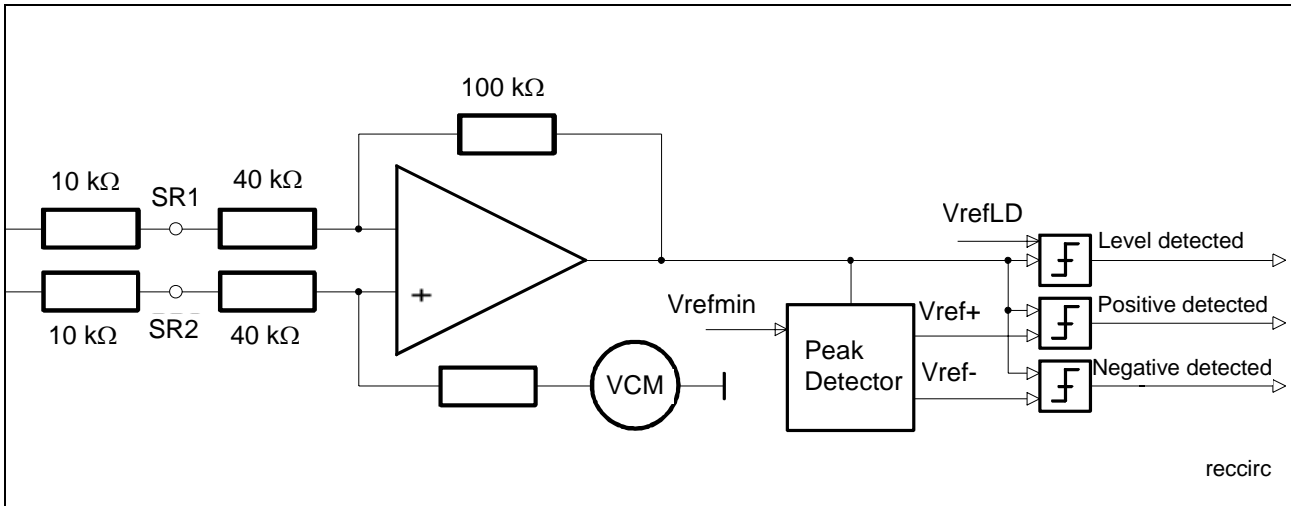

Figure 27 Equivalent Internal Circuit of the Receiver Stage

The input stage works together with external 10 kΩ resistors to match the input voltage to the internal thresholds. The data detection threshold V_{ref} is continuously adapted between a maximal (V_{refmax}) and a minimal (V_{refmin}) reference level related to the line level. The peak detector requires maximum 2 μs to reach the peak value while storing the peak level for at least 250 μs ($RC > 1$ ms).

The additional level detector for power up/down control works with a fixed thresholds V_{refLD} . The level detector monitors the line input signals to detect whether an INFO is present. When closing an analog loop it is therefore possible to indicate an incoming signal during activated loop.

3.3.7 S/T Interface Circuitry

For both, receive and transmit direction a 1:1 transformer is used to connect the ISAC-SX transceiver to the 4 wire S/T interface. Typical transformer characteristics can be found in the chapter on electrical characteristics. The connections of the line transformers is shown in **Figure 28**.

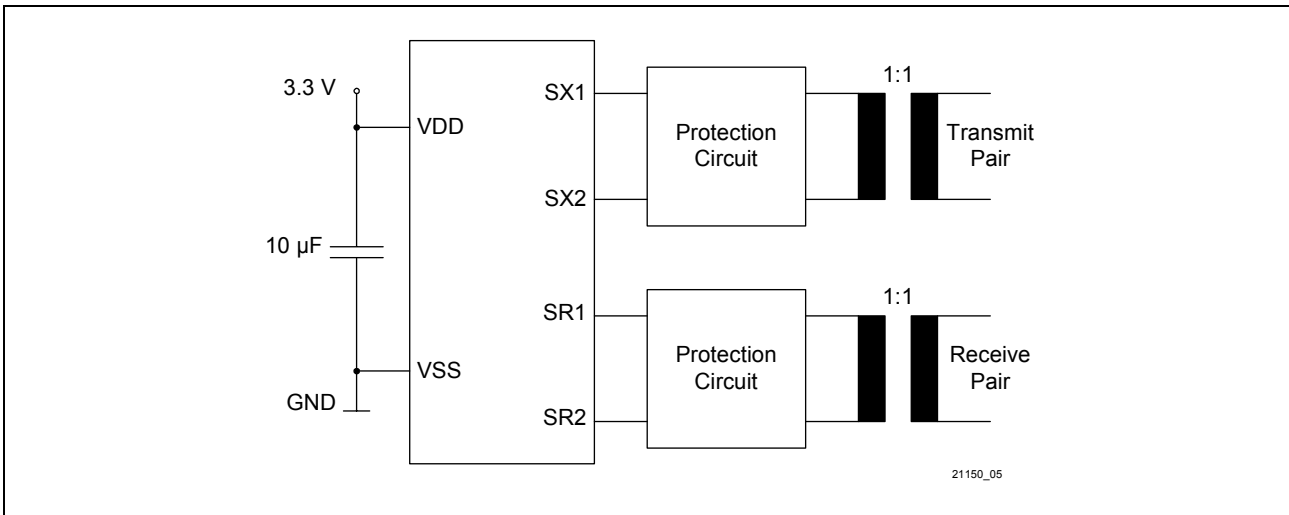

Figure 28 Connection of Line Transformers and Power Supply to the ISAC-SX

For the transmit direction an external transformer is required to provide isolation and pulse shape according to the ITU-T recommendations.

3.3.7.1 External Protection Circuitry

The ITU-T I.430 specification for both transmitter and receiver impedances in TEs results in a conflict with respect to external S-protection circuitry requirements:

- To avoid destruction or malfunction of the S-device it is desirable to drain off even small overvoltages reliably.
- To meet the 96 kHz impedance test specified for transmitters and receivers (for TEs only, ITU-T I.430 sections 8.5.1.2a and 8.6.1.1) the protection circuit must be dimensioned such that voltages below 1.2 V (ITU-T I.430 amplitude) x transformer ratio are not affected.

This requirement results from the fact that this test is also to be performed with no supply voltage being connected to the TE. Therefore the second reference point for overvoltages V_{DD} , is tied to GND. Then, if the amplitude of the 96 kHz test signal is greater than the combined forward voltages of the diodes, a current exceeding the specified one may pass the protection circuit.

The following recommendations aim at achieving the highest possible device protection against overvoltages while still fulfilling the 96 kHz impedance tests.

Protection Circuit for Transmitter

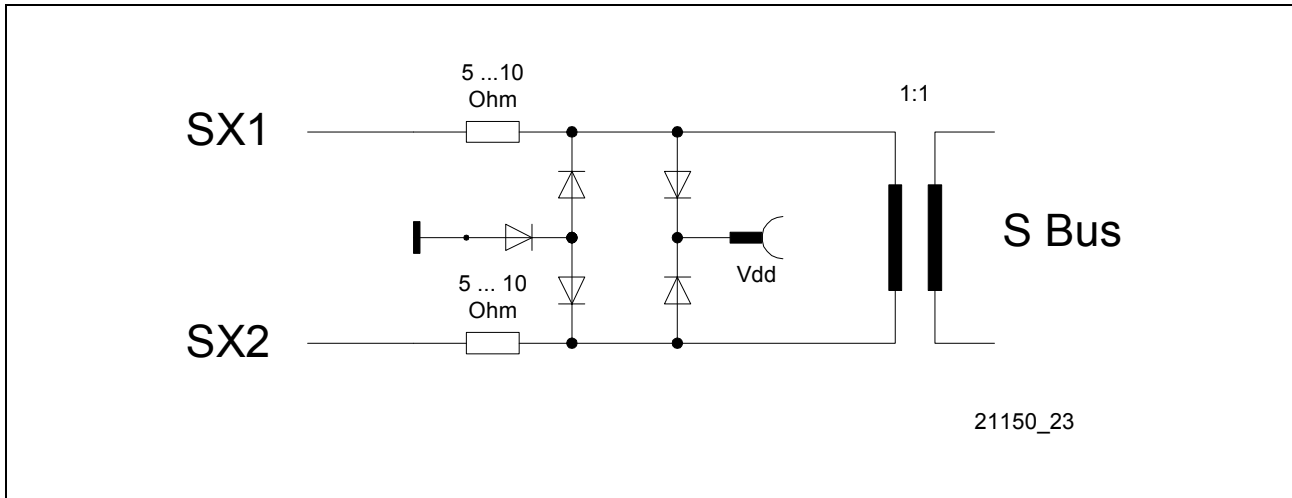

Figure 29 External Circuitry for Transmitter

Figure 29 illustrates the secondary protection circuit recommended for the transmitter. The external resistors (5 ... 10 Ω) are required in order to adjust the output voltage to the pulse mask on the one hand and in order to meet the output impedance of minimum 20 Ω (transmission of a binary zero according to ITU-T I.430) on the other hand. Two mutually reversed diode paths protect the device against positive or negative overvoltages on both lines.

An ideal protection circuit should limit the voltage at the SX pins from -0.4 V to $V_{DD} + 0.4\text{ V}$. With the circuit in **Figure 29** the pin voltage range is increased from -1.4 V to $V_{DD} + 0.7\text{ V}$. The resulting forward voltage of 1.4 V will prevent the protection circuit from becoming active if the 96 kHz test signal is applied while no supply voltage is present.

Protection Circuit for Receiver

Figure 30 illustrates the external circuitry used in combination with a symmetrical receiver. Protection of symmetrical receivers is rather simple.

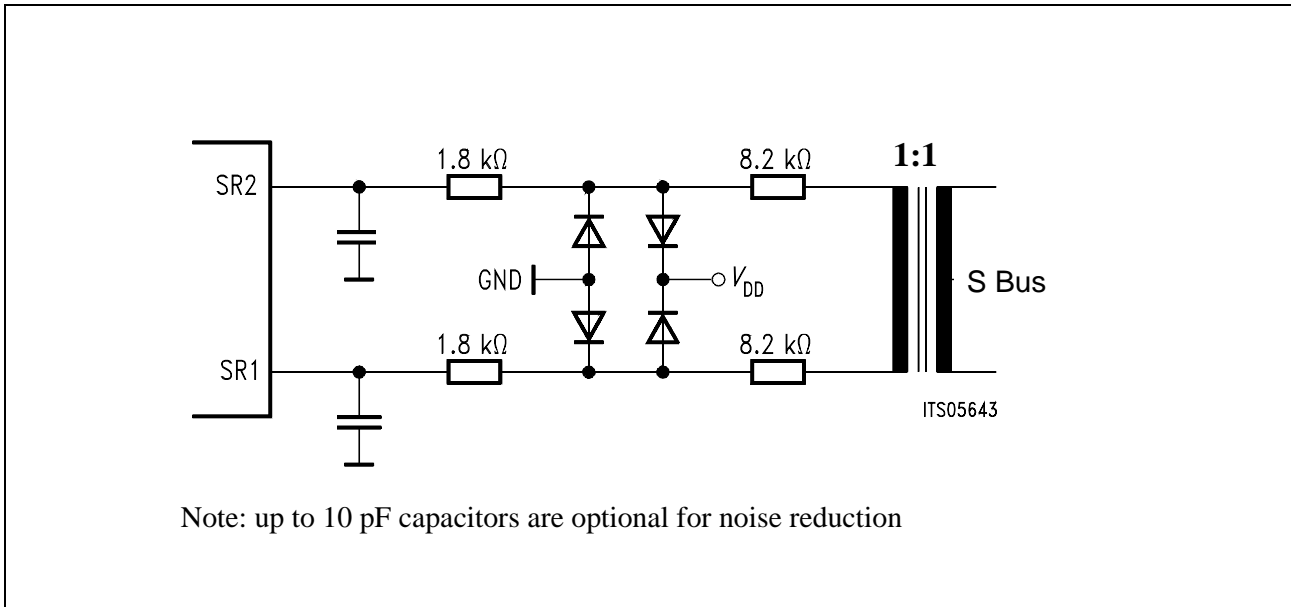

Figure 30 External Circuitry for Symmetrical Receivers

Between each receive line and the transformer a 10 kΩ resistor is used. This value is split into two resistors: one between transformer and protection diodes for current limiting during the 96 kHz test, and the second one between input pin and protection diodes to limit the maximum input current of the chip.

With symmetrical receivers no difficulties regarding LCL measurements are observed; compensation networks thus are obsolete.

In order to comply to the physical requirements of ITU-T recommendation I.430 and considering the national requirements concerning overvoltage protection and electromagnetic compatibility (EMC), the ISAC-SX may need additional circuitry.

3.3.7.2 S-Transceiver Synchronization

Synchronization problems can occur on a S-Bus that is not terminated properly. Therefore, it is recommended to change the resistor values in the receive path. The sum of both resistors is increased from 10 kΩ (1.8 + 8.2) to e.g. 34 kΩ (6.8 + 27) for either receiver line. This change is possible but not necessary for a S-Bus that is terminated properly.

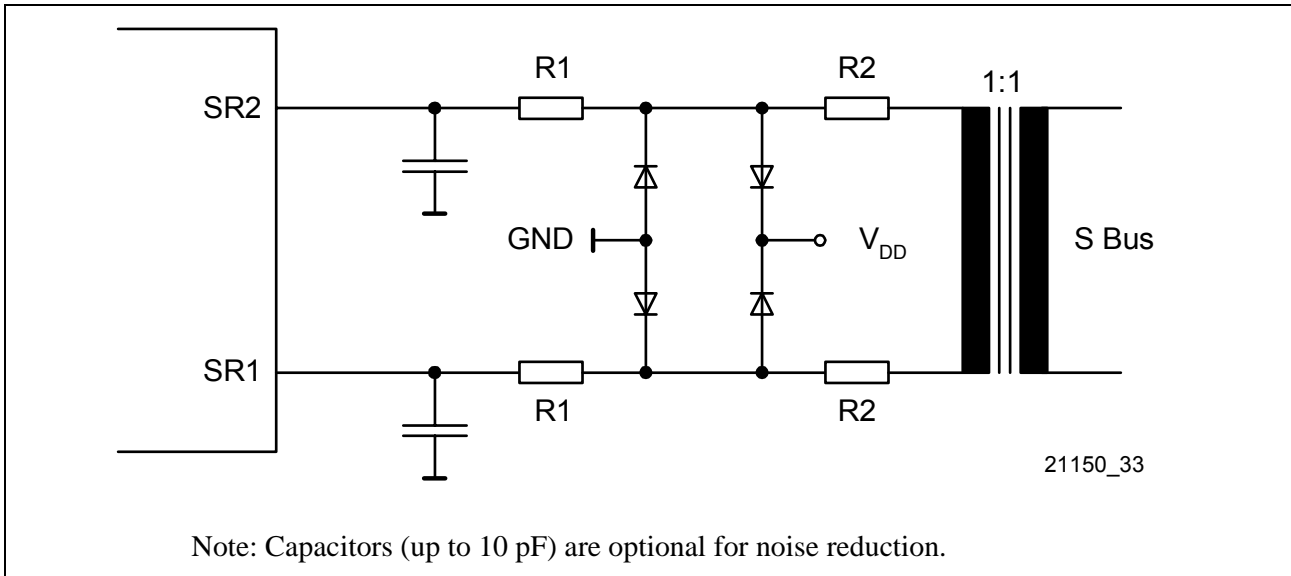

Figure 31 External Circuitry for Symmetrical Receivers

Note: Lower or higher values than 34 k Ω may be used as well, however for values above 34 k Ω the additional delay must be compensated by setting TR_CONF2.PDS=1 (compensates 260 ns) so the allowed input phase delay is not violated.

3.3.8 S/T Interface Delay Compensation (TE/LT-T mode)

The S/T transmitter is shifted by two S/T bits minus 7 oscillator periods (plus analog delay plus delay of the external circuitry) with respect to the received frame. To compensate additional delay introduced into the receive and transmit path by the external circuit the delay of the transmit data can be reduced by another two oscillator periods (2 x 130 ns). Therefore PDS of the TR_CONF2 register must be programmed to '1'. This delay compensation might be necessary in order to comply with the "total phase deviation input to output" requirement of ITU-T recommendation I.430 which specifies a phase deviation in the range of - 7% to + 15% of a bit period.

3.3.9 Level Detection Power Down

If MODE1.CFS is set to '0', the clocks are also provided in power down state, whereas if CFS is set to '1' only the analog level detector is active in power down state. All clocks, including the IOM-2 interface, are stopped (DD, DU are 'high', DCL and BCL are 'low'). An activation initiated from the exchange side will have the consequence that a clock signal is provided automatically if TR_CONF0.LDD is set to '0'. If TR_CONF0.LDD is set to '1' the microcontroller has to take care of an interrupt caused by the level detect circuit (ISTATR.LD)

From the terminal side an activation must be started by setting and resetting the SPU-bit in the IOM_CR register and writing TIM to the CIX0 register or by resetting MODE1.CFS=0.

3.3.10 Transceiver Enable/Disable

The layer-1 part of the ISAC-SX can be enabled/disabled by configuration (see [Figure 32](#)) with the two bits TR_CONF0.DIS_TR and TR_CONF2.DIS_TX.

By default all layer-1 functions with the exception of the transmitter buffer is enabled (DIS_TR = '0', DIS_TX = '1'). With several terminals connected to the S/T interface, another terminal may keep the interface activated although the ISAC-SX does not establish a connection. The receiver will monitor for incoming calls in this configuration. If the transceiver is disabled (DIS_TR = '1') all layer-1 functions are disabled including the level detection circuit of the receiver. In this case the power consumption of the Layer-1 is reduced to a minimum. The HDLC controller can still operate via IOM-2. The DCL and FSC pins become input.

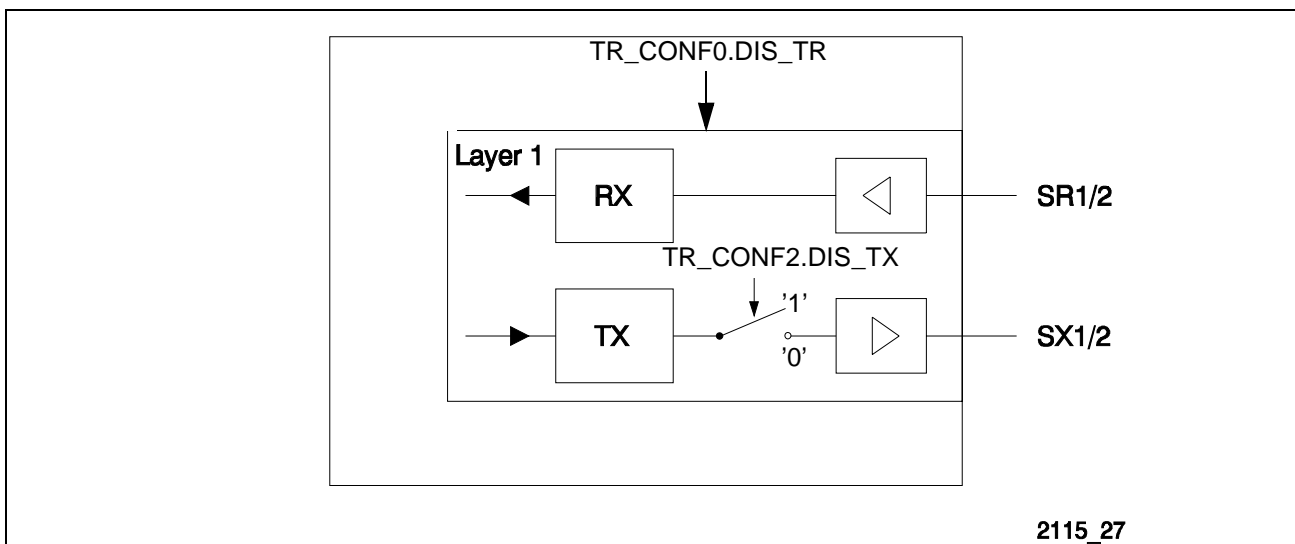

Figure 32 Disabling of S/T Transmitter

3.3.11 Test Functions

The ISAC-SX provides test and diagnostic functions for the S/T interface:

Note: For more details please refer to the application note "Test Function of new S-Transceiver family"

- The **internal local loop** (internal Loop A) is activated by a C/I command ARL or by setting the bit LP_A (Loop Analog) in the TR_CMD register if the layer-1 statemachine is disabled.

The transmit data of the transmitter is looped back internally to the receiver. The data of the IOM-2 input B- and D-channels are looped back to the output B- and D-channels.

The S/T interface level detector is enabled, i.e. if a level is detected this will be reported by the Resynchronization Indication (RSY) but the loop function is not affected.

Description of Functional Blocks

Depending on the DIS_TX bit in the TR_CONF2 register the internal local loop can be transparent or non transparent to the S/T line.

- The **external local loop** (external Loop A) is activated in the same way as the internal local loop described above. Additionally the EXLP bit in the TR_CONF0 register has to be programmed and the loop has to be closed externally as described in [Figure 33](#). The S/T interface level detector is disabled.

This allows complete system diagnostics.

- In **remote line loop** (RLP) received data is looped back to the S/T interface. The D-channel information received from the line card is transparently forwarded to the output IOM-2 D-channel. The output B-channel information on IOM-2 is fixed to 'FF'_H while this test loop is active. The remote line loop is programmable in TR_CONF2.RLP.

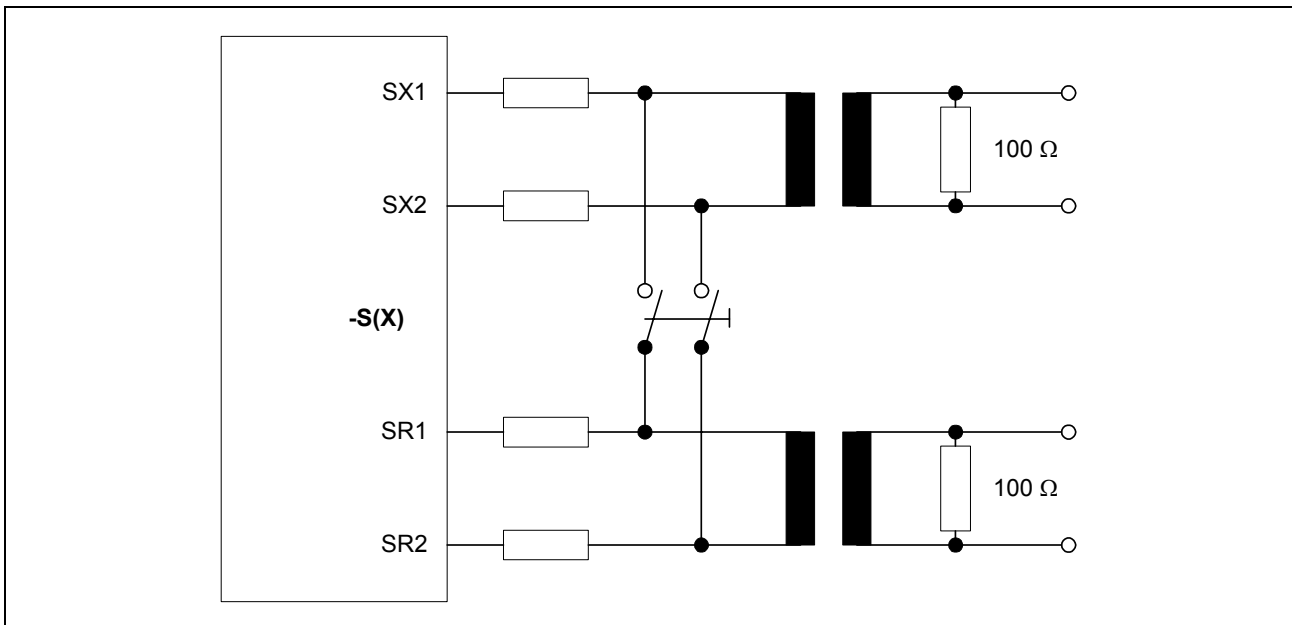

Figure 33 External Loop at the S/T-Interface

- transmission of special test signals on the S/T interface according to the modified AMI code are initiated via a C/I command written in CIX0 register (see [Chapter 3.5.4](#))

Two kinds of test signals may be transmitted by the ISAC-SX:

- The single pulses are of alternating polarity. One pulse is transmitted in each frame resulting in a frequency of the fundamental mode of 2 kHz. The corresponding C/I command is SSP (Send Single Pulses).
- The continuous pulses are of alternating polarity. 48 pulses are transmitted in each frame resulting in a frequency of the fundamental mode of 96 kHz. The corresponding C/I command is SCP (Send Continuous Pulses).

3.4 Clock Generation

Figure 34 shows the clock system of the ISAC-SX. The oscillator is used to generate a 7.68 MHz clock signal (f_{XTAL}). In TE mode the DPLL generates the IOM-2 clocks FSC (8 kHz), DCL (1536 kHz) and BCL (768 kHz) synchronous to the received S/T frames. In LT modes these pins are input and in LT-T mode an 1536 kHz clock synchronous to S is output at SCLK which can be used for DCL input.

An internal clock divider provides an FSC (ACFG2.FBS=0) or BCL (ACFG2.FBS=1) output on pin AUX5/FBOUT derived from the DCL clock. The output can be enabled via ACFG2.A5SEL=1.

The FSC signal is used to generate the pulse lengths of the different reset sources C/I Code, \overline{EAW} pin and Watchdog (see **Figure 3.2.4**).

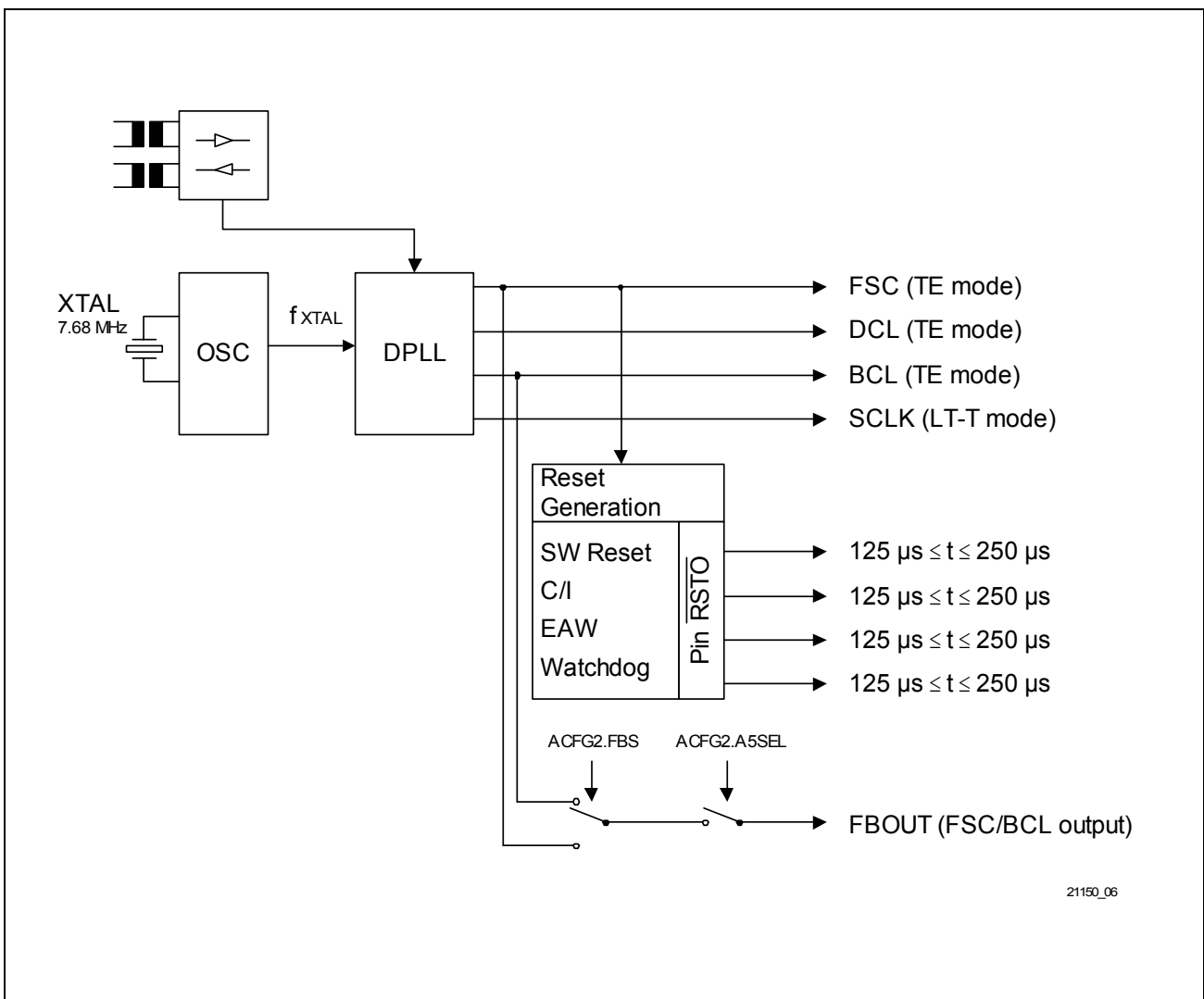

Figure 34 Clock System of the ISAC-SX

Description of Functional Blocks
Table 9 Clock Modes

	TE	LT-T	LT-S	NT	Int. NT
Selected via	pin: MODE0=0	pin:MODE1=0 MODE0=1	pin:MODE1=1 MODE0=1	bit:MODE2=0 MODE1=1 MODE0=0	bit:MODE2=1 MODE1=1 MODE0=1 or MODE0=0 *1)
FSC	o:8 kHz (DIS_TR=0) i:8 kHz (DIS_TR=1) *2)	i:8 kHz	i:8 kHz	i:8 kHz	i:8 kHz
DCL	o:1536 kHz (DIS_TR=0) i:1536/768 kHz (DIS_TR=1) *2)	i:1536 kHz (from SCLK) or 4096 kHz (from ext. PLL)	i:512 kHz or 1536 kHz or 4096 kHz	i:512 kHz or 1536 kHz or 4096 kHz	i:1536 kHz
BCL/SCLK	o:768 kHz (BCL)	o:1536 kHz (SCLK) *5)	o:256 kHz or 768 kHz or 2048 kHz (derived from DCL/2)	o:256 kHz or 768 kHz or 2048 kHz (derived from DCL/2)	o:768 kHz (derived from DCL/2)
DU *6)	i	i	o	o	o
DD	o	o	i	i	i
AUX5/FBOUT (A5SEL=1) *3)	o:FSC (FBS=0) or BCL (FBS=1)	o:FSC (FBS=0) or BCL (FBS=1)	o:FSC (FBS=0) or BCL (FBS=1)	o:FSC (FBS=0) or BCL (FBS=1)	o:FSC (FBS=0) or BCL (FBS=1)
AUX0-2	general purpose I/O pins	CH0-2: strap pins for IOM channel select *4)	CH0-2: strap pins for IOM channel select *4)	CH0-2: strap pins for IOM channel select *4)	general purpose I/O pins

Description of Functional Blocks

Note: The IOM-2 interface is adaptive. This means in LT-S/NT and LT-T mode other frequencies for BCL and DCL are possible in the range of 512-4096 kHz (DCL) and 256-2048 kHz (BCL). For details please refer to the application note "Reconfigurable PBX".

Note: *i* = input; *o* = output;

For all input clocks typical values are given although other clock frequencies may be used, too.

1) The modes TE, LT-T and LT-S can directly be selected by strapping the pins MODE1 and MODE0. The mode can be reprogrammed in TR_MODE.MODE2-0 where NT and Intelligent NT can be selected additionally. In Int. NT mode MODE0 selects between NT state machine (0) and LT-S state machine (1).

2) In TE mode the S transceiver can be disabled (TR_CONF0.DIS_TR=1) so the IOM clocks become inputs and with IOM_CR.CLKM the DCL input can be selected to double clock (0) or single bit clock (1).

3) ACFG2.A5SEL=1 selects the FBOUT function (derived from IOM clocks) which provides an FSC/BCL output clock if clocks are present on IOM.

4) The number of IOM channels depends on the DCL clock, e.g. with DCL=1536 kHz 3 IOM channels and with DCL= 4096 kHz 8 channels are available.

5) In LT-T mode the 1536 kHz output clock on SCLK is synchronous to the S interface and can be used as input for the DCL clock.<

6) The direction input/output refers to the direction of the B- and D-channel data stream across the S-transceiver. Due to the capabilities of the IOM-2 handler the direction of some other timeslots may be different if this is programmed by the host (e.g. for data exchange between different devices connected to IOM-2).

3.4.1 Description of the Receive PLL (DPLL)

The receive PLL performs phase tracking between the F/L transition of the receive signal and the recovered clock. Phase adjustment is done by adding or subtracting 0.5 or 1 XTAL period to or from a 1.536-MHz clock cycle. The 1.536-MHz clock is then used to generate any other clock synchronized to the line.

During (re)synchronization an internal reset condition may effect the 1.536-MHz clock to have high or low times as short as 130 ns. After the S/T interface frame has achieved the synchronized state (after three consecutive valid pairs of code violations) the FSC output in TE mode is set to a specific phase relationship, thus causing once an irregular FSC timing.

The phase relationships of the clocks are shown in [Chapter 35](#).

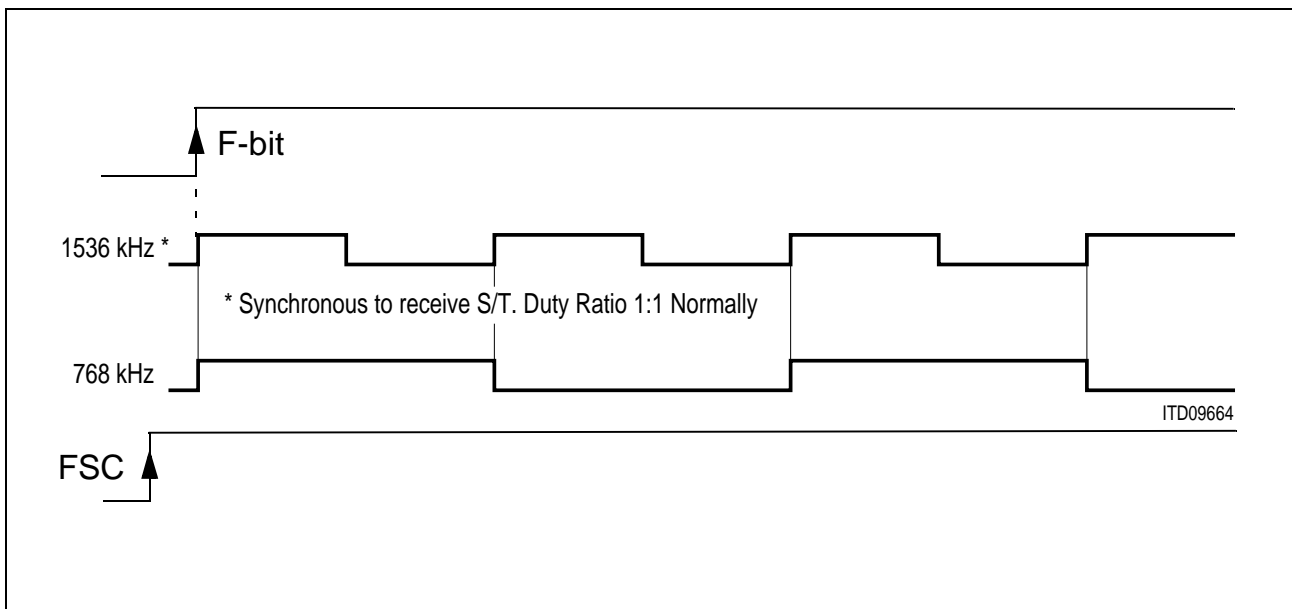

Figure 35 Phase Relationships of ISAC-SX Clock Signals

3.4.2 Jitter

The timing extraction jitter of the ISAC-SX conforms to ITU-T Recommendation I.430 (– 7% to + 7% of the S-interface bit period).

3.4.3 Oscillator Clock Output C768

The ISAC-SX derives its system clocks from an external clock connected to XTAL1 (while XTAL2 is not connected) or from a 7.68 MHz crystal connected across XTAL1 and XTAL2.

At pin C768 a buffered 7.68 MHz output clock is provided to drive further devices, which is suitable in multiline applications for example (see [Figure 36](#)). This clock is not synchronized to the S-interface.

In power down mode the C768 output is disabled (low signal).

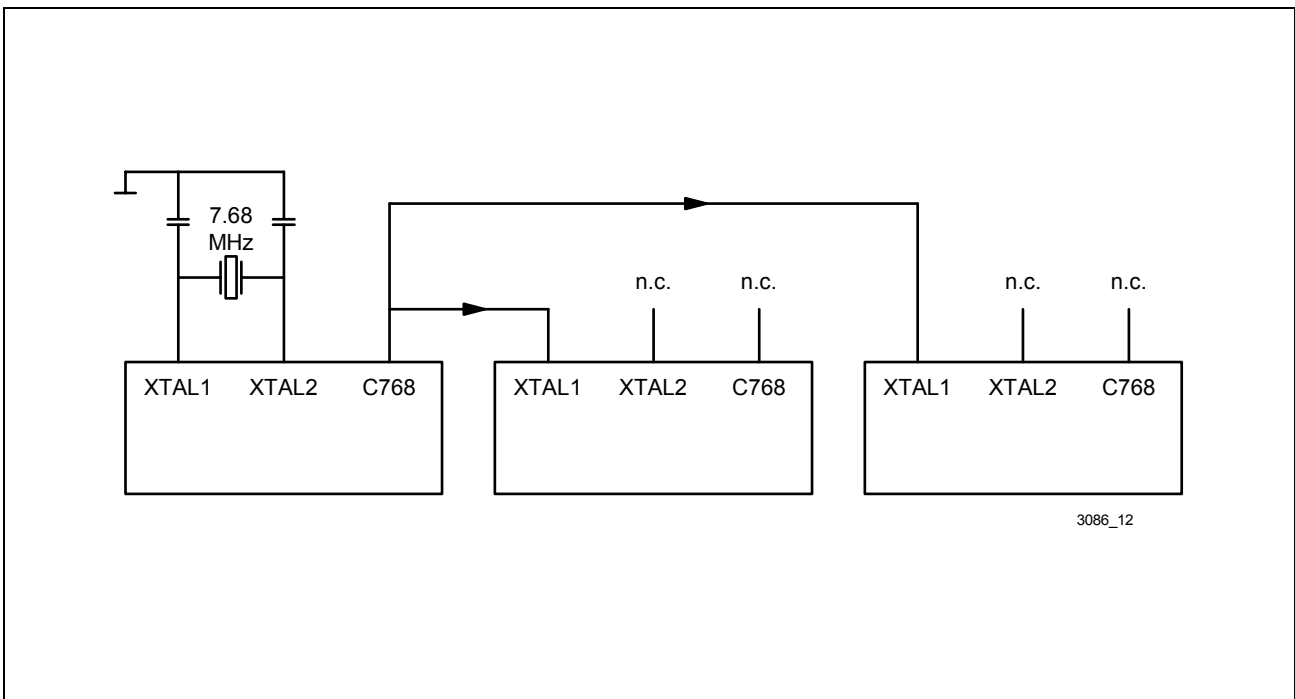

Figure 36 Buffered Oscillator Clock Output

3.5 Control of Layer-1

The layer-1 activation/ deactivation can be controlled by an internal state machine via the IOM-2 C/I0 channel or by software via the microcontroller interface directly. In the default state the internal layer-1 state machine of the ISAC-SX is used. By setting the L1SW bit in the TR_CONF0 register the internal state machine can be disabled and the layer-1 commands, which are normally generated by the internal state machine are written directly in the TR_CMD register or indications read from the TR_STA register respectively. The ISAC-SX layer-1 control flow is shown in [Figure 37](#).

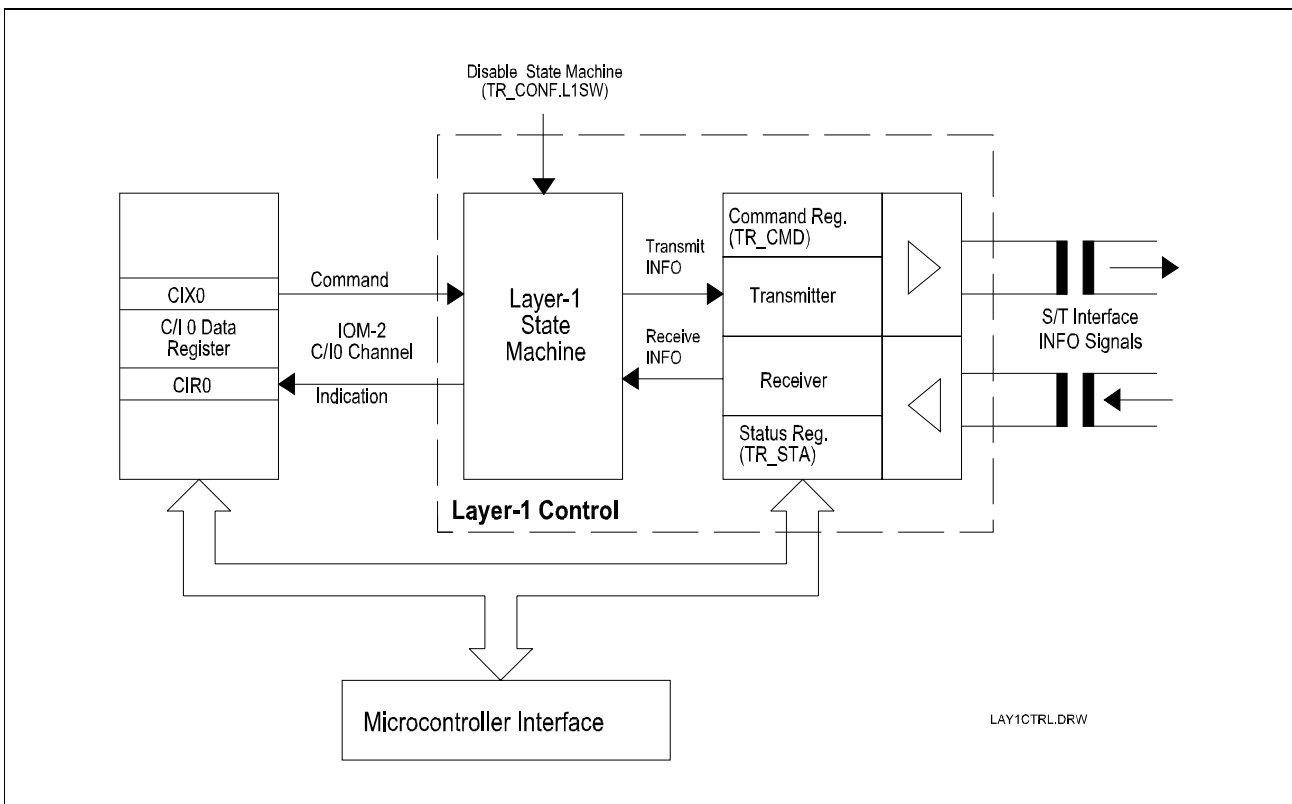

Figure 37 Layer-1 Control

In the following sections the layer-1 control by the ISAC-SX state machine will be described. For the description of the IOM-2 C/I0 channel see also [Chapter 3.7.4](#).

The layer-1 functions are controlled by commands issued via the CIX0 register. These commands, sent over the IOM-2 C/I channel 0 to layer 1, trigger certain procedures, such as activation/deactivation, switching of test loops and transmission of special pulse patterns. These procedures are governed by layer-1 state diagrams. Responses from layer 1 are obtained by reading the CIR0 register after a CIC interrupt (ISTA).

The state diagrams of the ISAC-SX are shown in [Figure 39](#) and [Figure 40](#). The activation/deactivation implemented by the ISAC-SX agrees with the requirements set forth in ITU recommendations. State identifiers F1-F8 are in accordance with ITU I.430.

Description of Functional Blocks

State machines are the key to understanding the transceiver part of the ISAC-SX. They include all information relevant to the user and enable him to understand and predict the behaviour of the ISAC-SX. The state diagram notation is given in **Figure 38**. The informations contained in the state diagrams are:

- state name (based on ITU I.430)
- S/T signal transmitted (INFO)
- C/I code received
- C/I code transmitted
- transition criteria

The coding of the C/I commands and indications are described in detail in **Chapter 3.5.4**.

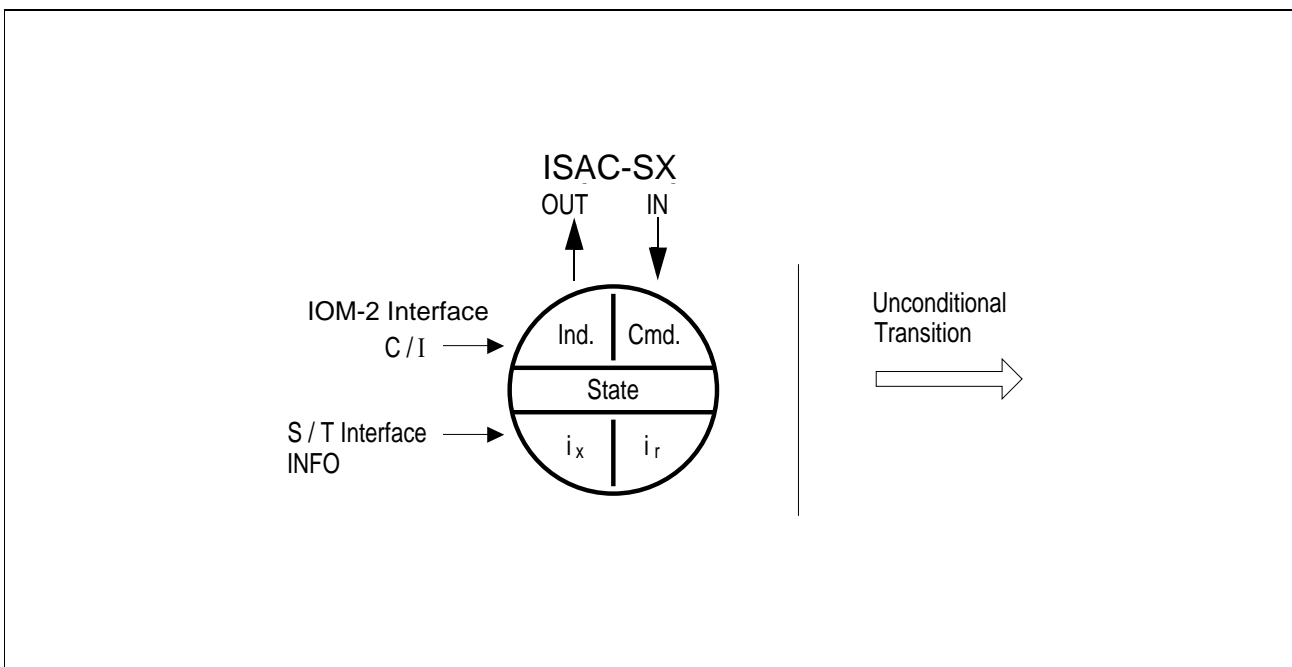

Figure 38 State Diagram Notation

The following example illustrates the use of a state diagram with an extract of the TE state diagram. The state explained is “F3 deactivated”.

The state may be entered:

- from the unconditional states (ARL, RES, TM)
- from state “F3 pending deactivation”, “F3 power up”, “F4 pending activation” or “F5 unsynchronized” after the C/I command “DI” has been received.

The following informations are transmitted:

- INFO 0 (no signal) is sent on the S/T-interface.

C/I message “DC” is issued on the IOM-2 interface.

The state may be left by either of the following methods:

- Leave for the state “F3 power up” in case C/I = “TIM” code is received.
- Leave for state “F4 pending activation” in case C/I = AR8 or AR10 is received.

Description of Functional Blocks

- Leave for the state “F6 synchronized” after INFO 2 has been recognized on the S/T-interface.
- Leave for the state “F7 activated” after INFO 4 has been recognized on the S/T-interface.
- Leave for any unconditional state if any unconditional C/I command is received.

As can be seen from the transition criteria, combinations of multiple conditions are possible as well. A “*” stands for a logical AND combination. And a “+” indicates a logical OR combination.

The sections following the state diagram contain detailed information on all states and signals used.

3.5.1 State Machine TE and LT-T Mode

3.5.1.1 State Transition Diagram (TE, LT-T)

Figure 39 shows the state transition diagram of the ISAC-SX state machine. **Figure 40** shows this for the unconditional transitions (Reset, Loop, Test Mode i).

Description of Functional Blocks

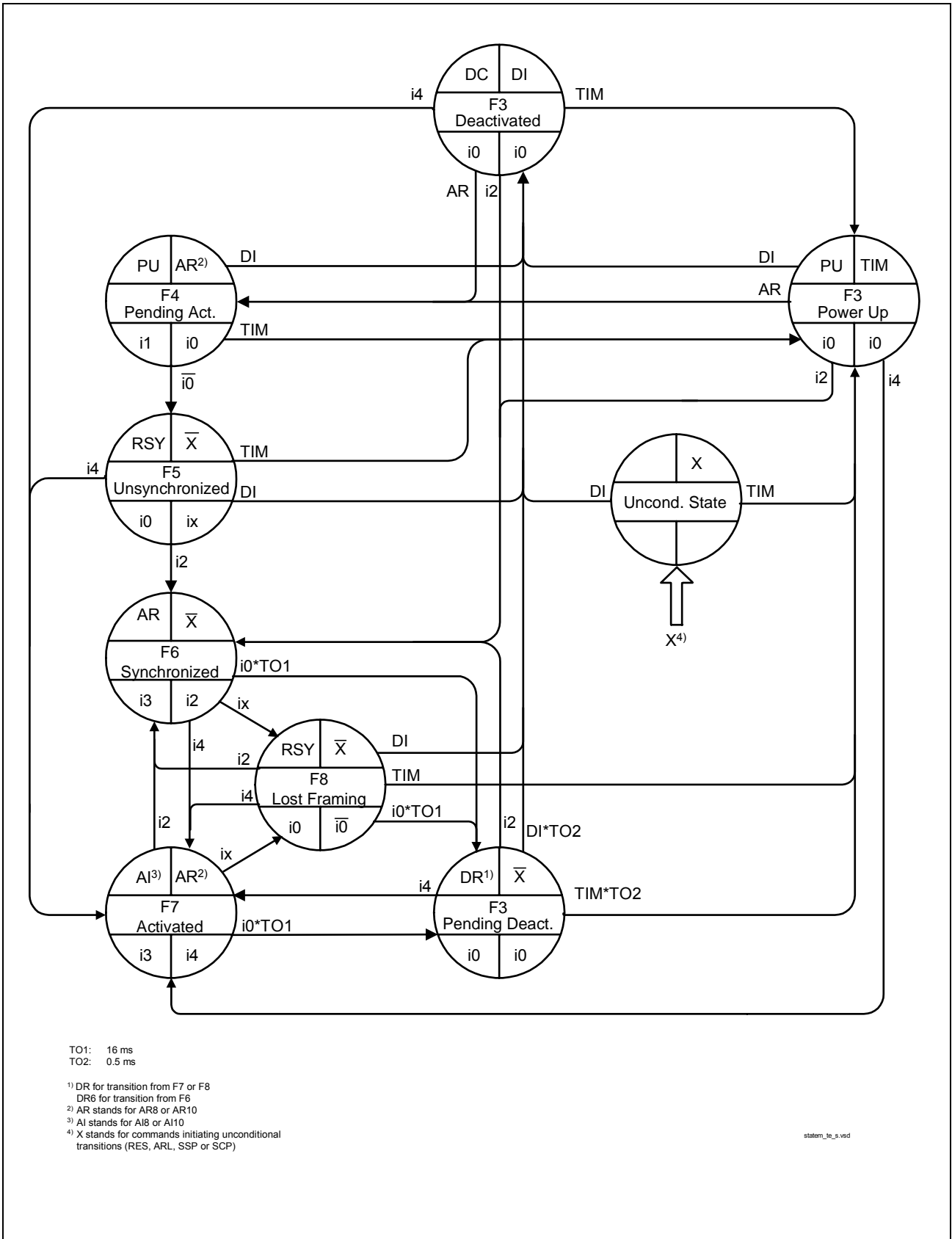
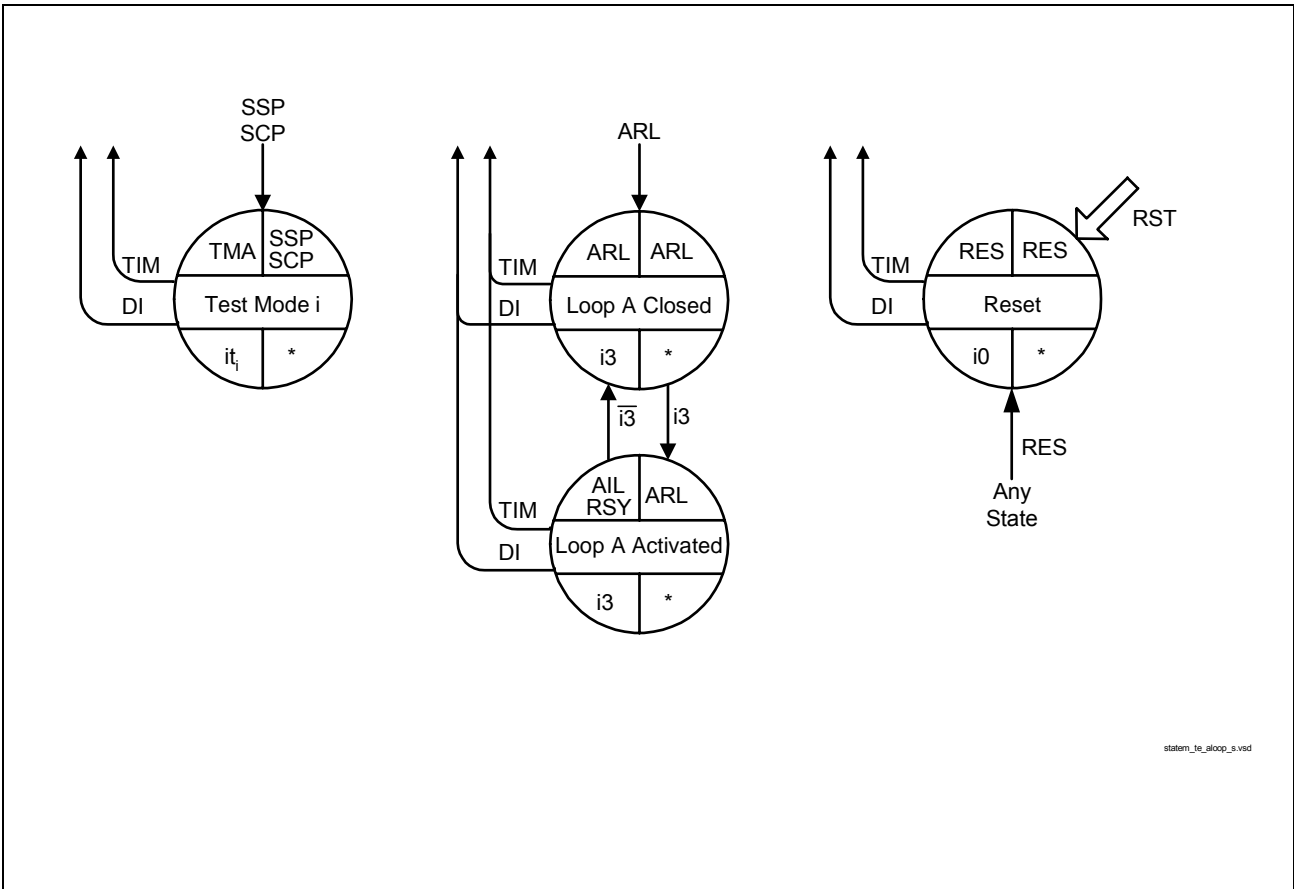

Figure 39 State Transition Diagram (TE, LT-T)

Description of Functional Blocks



state_m_to_loop_a_vsd

Figure 40 State Transition Diagram of Unconditional Transitions (TE, LT-T)

3.5.1.2 States (TE, LT-T)

F3 Pending Deactivation

State after deactivation from the S/T interface by info 0. Note that no activation from the terminal side is possible starting from this state. A 'DI' command has to be issued to enter the state 'Deactivated State'.

F3 Deactivated State

The S/T interface is deactivated and the clocks are deactivated 500 μ s after entering this state and receiving info 0 if the CFS bit of the ISAC-SX Configuration Register is set to "0". Activation is possible from the S/T interface and from the IOM-2 interface. The bit TR_CMD.PD is set and the analog part is powered down.

F3 Power Up

The S/T interface is deactivated (info 0 on the line) and the clocks are running.

F4 Pending Activation

The ISAC-SX transmits info 1 towards the network, waiting for info 2.

F5 Unsynchronized

Description of Functional Blocks

Any signal except info 2 or 4 detected on the S/T interface.

F6 Synchronized

The receiver has synchronized and detects info 2. Info 3 is transmitted to synchronize the NT.

F7 Activated

The receiver has synchronized and detects info 4. All user channels are now conveyed transparently to the IOM-2 interface.

To transfer user channels transparently to the S/T interface either the command AR8 or AR10 has to be issued and TR_STA.FSYN must be "1" (signal from remote side must be synchronous).

F8 Lost Framing

The receiver has lost synchronization in the states F6 or F7 respectively.

Unconditional States**Loop A Closed (internal or external)**

The ISAC-SX loops back the transmitter to the receiver and activates by transmission of info 3. The receiver has not yet synchronized.

For a non transparent internal loop the DIS_TX bit of register TR_CONF2 has to be set to '1'.

Loop A Activated (internal or external)

The receiver has synchronized to info 3. Data may be sent. The indication "AIL" is output to indicate the activated state. If the loop is closed internally and the S/T line awake detector detects any signal on the S/T interface, this is indicated by "RSY".

Test Mode - SSP

Single alternating pulses are transmitted to the S/T-interface resulting in a frequency of the fundamental mode of 2 kHz.

Test Mode - SCP

Continuous alternating pulses are transmitted to the S/T-interface resulting in a frequency of the fundamental mode of 96 kHz.

Description of Functional Blocks
3.5.1.3 C/I Codes (TE, LT-T)

Command	Abbr.	Code	Remark
Activation Request with priority class 8	AR8	1000	Activation requested by the ISAC-SX, D-channel priority set to 8 (see note)
Activation Request with priority class 10	AR10	1001	Activation requested by the ISAC-SX, D-channel priority set to 10 (see note)
Activation Request Loop	ARL	1010	Activation requested for the internal or external Loop A (see note). For a non transparent internal loop bit DIS_TX of register TR_CONF2 has to be set to '1' additionally.
Deactivation Indication	DI	1111	Deactivation Indication
Reset	RES	0001	Reset of the layer-1 statemachine
Timing	TIM	0000	Layer-2 device requires clocks to be activated
Test mode SSP	SSP	0010	One AMI-coded pulse transmitted in each frame, resulting in a frequency of the fundamental mode of 2 kHz
Test mode SCP	SCP	0011	AMI-coded pulses transmitted continuously, resulting in a frequency of the fundamental mode of 96 kHz

Note: In the activated states (AI8, AI10 or AIL indication) the 2B+D channels are only transferred transparently to the S/T interface if one of the three "Activation Request" commands is permanently issued.

Indication	Abbr.	Code	Remark
Deactivation Request	DR	0000	Deactivation request via S/T-interface if left from F7/F8
Reset	RES	0001	Reset acknowledge
Test Mode Acknowledge	TMA	0010	Acknowledge for both SSP and SCP
Slip Detected	SLD	0011	
Resynchronization during level detect	RSY	0100	Signal received, receiver not synchronous

Description of Functional Blocks

Indication	Abbr.	Code	Remark
Deactivation Request from F6	DR6	0101	Deactivation Request from state F6
Power up	PU	0111	IOM-2 interface clocking is provided
Activation request	AR	1000	Info 2 received
Activation request loop	ARL	1010	Internal or external loop A closed
Illegal Code Violation	CVR	1011	Illegal code violation received. This function has to be enabled by setting the EN_ICV bit of register TR_CONF0.
Activation indication loop	AIL	1110	Internal or external loop A activated
Activation indication with priority class 8	AI8	1100	Info 4 received, D-channel priority is 8 or 9.
Activation indication with priority class 10	AI10	1101	Info 4 received, D-channel priority is 10 or 11.
Deactivation confirmation	DC	1111	Clocks are disabled if CFS bit of register MODE1 is set to '1', quiescent state

Description of Functional Blocks

3.5.1.4 Infos on S/T (TE, LT-T)

Receive Infos on S/T (Downstream)

Name	Abbr.	Description
info 0	i0	No signal on S/T
info 2	i2	4 kHz frame A='0'
info 4	i4	4 kHz frame A='1'
info X	ix	Any signal except info 2 or info 4

Transmit Infos on S/T (Upstream)

Name	Abbr.	Description
info 0	i0	No signal on S/T
info 1	i1	Continuous bit sequence of the form '00111111'
info 3	i3	4 kHz frame
Test info 1	it ₁	SSP - Send Single Pulses
Test info 2	it ₂	SCP - Send Continuous Pulses

3.5.2 State Machine LT-S Mode

3.5.2.1 State Transition Diagram (LT-S)

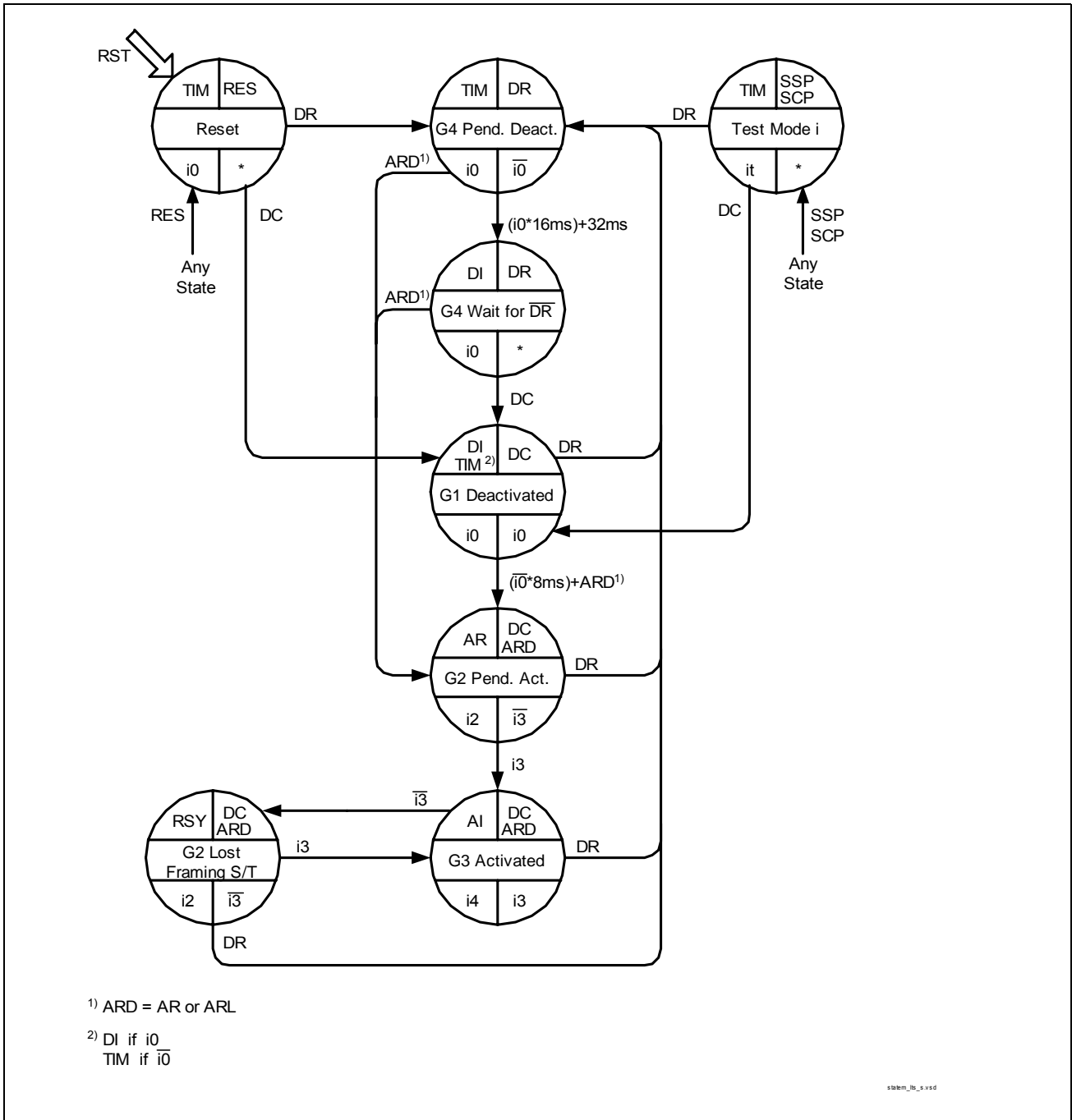

Figure 41 State Transition Diagram (LT-S)

Note: State 'Test Mode' can be entered from any state except from state 'Test Mode' itself, i.e. C/I-code 'SSP/SCP' must not be followed by C/I-code 'SCP/SSP' directly.

3.5.2.2 States (LT-S)

G1 deactivated

The transceiver is not transmitting. There is no signal detected on the S/T-interface, and no activation command is received in the C/I channel. The clocks are deactivated if MODE1-CFS is set to 1. Activation is possible from the S/T interface and from the IOM-2 interface.

G2 pending activation

As a result of an $\overline{\text{INFO 0}}$ detected on the S/T line or an ARD command, the transceiver begins transmitting INFO 2 and waits for reception of INFO 3. The timer to supervise reception of INFO 3 is to be implemented in software. In case of an ARL command, loop 2 is closed.

G3 activated

Normal state where INFO 4 is transmitted to the S/T-interface. The transceiver remains in this state as long as neither a deactivation nor a test mode is requested, nor the receiver loses synchronism.

When receiver synchronism is lost, INFO 2 is sent automatically. After reception of INFO 3, the transmitter keeps on sending INFO 4.

G2 lost framing

This state is reached when the transceiver has lost synchronism in the state G3 activated.

G4 pending deactivation

This state is triggered by a deactivation request DR. It is an unstable state: indication DI (state "G4 wait for DR.") is issued by the transceiver when:

either INFO0 is received for a duration of 16 ms,
or an internal timer of 32 ms expires.

G4 wait for $\overline{\text{DR}}$

Final state after a deactivation request. The transceiver remains in this state until DC is issued.

Unconditional States

Test mode - SSP

Single alternating pulses are sent on the S/T-interface.

Description of Functional Blocks
Test mode - SCP

Continuous alternating pulses are sent on the S/T-interface.

3.5.2.3 C/I Codes (LT-S)

Command	Abbr.	Code	Remark
Deactivation Request	DR	0000	DR - Deactivation Request. Initiates a complete deactivation from the exchange side by transmitting INFO 0.
Reset	RES	0001	Reset of state machine. Transmission of Info0. No reaction to incoming infos. RES is an unconditional command.
Send Single Pulses	SSP	0010	Send Single Pulses.
Send Continuous Pulses	SCP	0011	Send Continuous Pulses.
Activation Request	AR	1000	Activation Request. This command is used to start an exchange initiated activation.
Activation Request Loop	ARL	1010	Activation request loop. The transceiver is requested to operate an analog loop-back close to the S/T-interface.
Activation Indication Loop	AIL	1110	Activation Indication Loop
Deactivation Confirmation	DC	1111	Deactivation Confirmation. Transfers the transceiver into a deactivated state in which it can be activated from a terminal (detection of $\overline{\text{INFO 0}}$ enabled).

Indication	Abbr.	Code	Remark
Timing	TIM	0000	Interim indication during activation procedure in G1.
Receiver not Synchronous	RSY	0100	Receiver is not synchronous
Activation Request	AR	1000	$\overline{\text{INFO 0}}$ received from terminal. Activation proceeds.
Illegal Code Ciolation	CVR	1011	Illegal code violation received. This function has to be enabled in TR_CONF0.EN_ICV.

Description of Functional Blocks

Indication	Abbr.	Code	Remark
Activation Indication	AI	1100	Synchronous receiver, i.e. activation completed.
Deactivation Indication	DI	1111	Timer (32 ms) expired or INFO 0 received for a duration of 16 ms after deactivation request

3.5.2.4 Infos on S/T (LT-S)

Receive Infos on S/T (Downstream)

- I0 INFO 0 detected
- $\bar{I}0$ Level detected (signal different to I0)
- I3 INFO 3 detected
- $\bar{I}3$ Any INFO other than INFO 3

Transmit Infos on S/T (Upstream)

- I0 INFO 0
- I2 INFO 2
- I4 INFO 4
- It Send Single Pulses (SSP).
Send Continuous Pulses (SCP).

3.5.3 State Machine NT Mode

3.5.3.1 State Transition Diagram (NT)

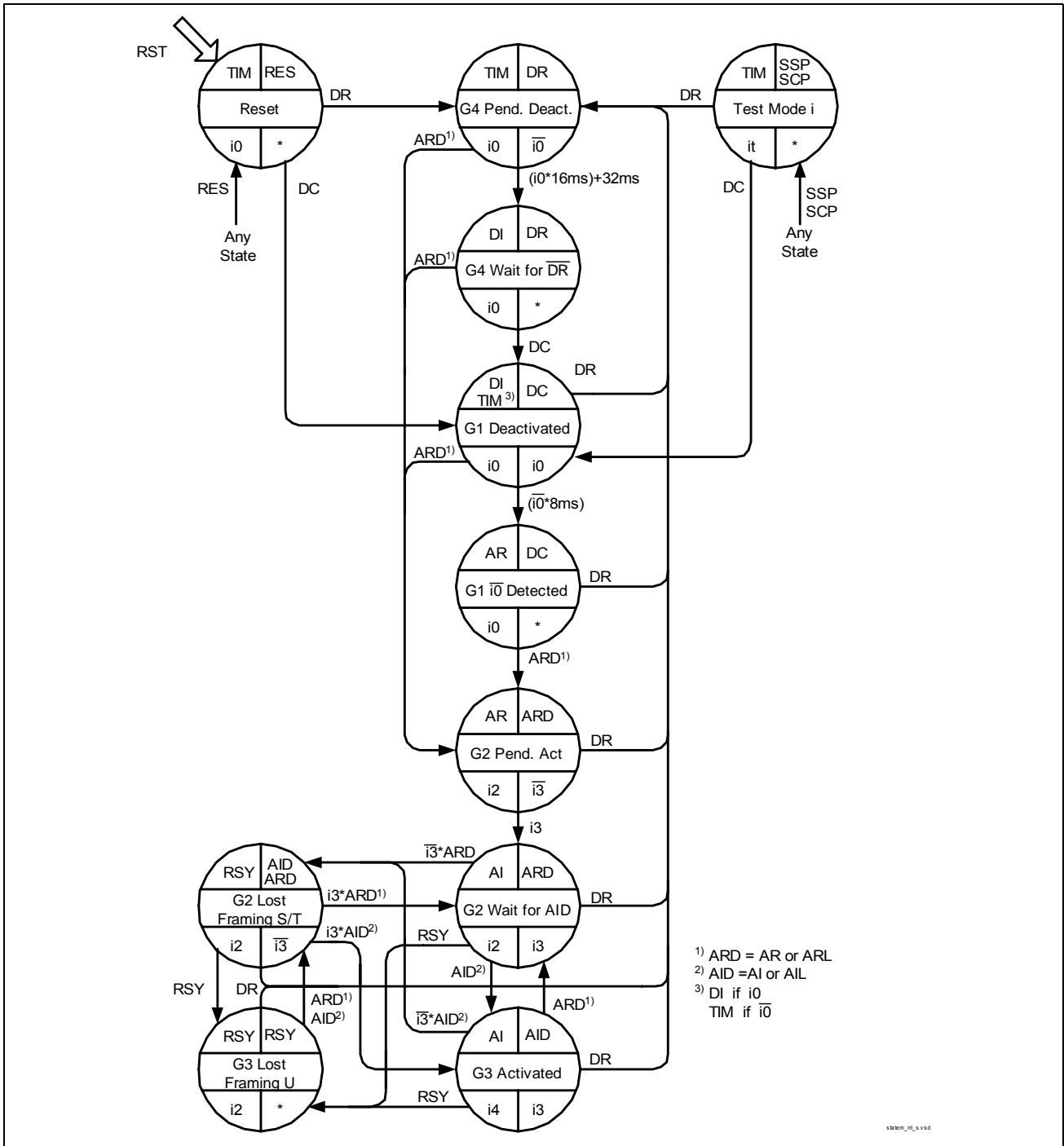

Figure 42 State Transition Diagram (NT)

Note: State 'Test Mode' can be entered from any state except from state 'Test Mode' itself, i.e. C/I-code 'SSP/SCP' must not be followed by C/I-code 'SCP/SSP' directly

3.5.3.2 States (NT)

G1 Deactivated

The transceiver is not transmitting. There is no signal detected on the S/T-interface, and no activation command is received in the C/I channel. The clocks are deactivated if the bit MODE1.CFS to 1. Activation is possible from the S/T interface and from the IOM-2 interface.

G1 $\overline{\text{I0}}$ Detected

An $\overline{\text{INFO 0}}$ is detected on the S/T-interface, translated to an "Activation Request" indication in the C/I channel. The transceiver is waiting for an AR command, which normally indicates that the transmission line upstream (usually a two-wire U interface) is synchronized.

G2 Pending Activation

As a result of the ARD command, an INFO 2 is sent on the S/T-interface. INFO 3 is not yet received. In case of ARL command, loop 2 is closed.

G2 wait for AID

INFO 3 was received, INFO 2 continues to be transmitted while the transceiver waits for a "switch-through" command AID from the device upstream.

G3 Activated

INFO 4 is sent on the S/T-interface as a result of the "switch through" command AID: the B and D-channels are transparent. On the command AIL, loop 2 is closed.

G2 Lost Framing S/T

This state is reached when the transceiver has lost synchronism in the state G3 activated.

G3 Lost Framing U

On receiving an RSY command which usually indicates that synchronization has been lost on the two-wire U interface, the transceiver transmits INFO 2.

G4 Pending Deactivation

This state is triggered by a deactivation request DR, and is an unstable state. Indication DI (state "G4 wait for DR") is issued by the transceiver when:

either INFO0 is received for a duration of 16 ms

Description of Functional Blocks

or an internal timer of 32 ms expires.

G4 wait for \overline{DR}

Final state after a deactivation request. The transceiver remains in this state until DC is issued.

Unconditional States

Test Mode SSP

Send Single Pulses

Test Mode SCP

Send Continuous Pulses

3.5.3.3 C/I Codes (NT)

Command	Abbr.	Code	Remark
Deactivation Request	DR	0000	DR - Deactivation Request. Initiates a complete deactivation from the exchange side by transmitting INFO 0. Unconditional command.
Reset	RES	0001	Reset of state machine. Transmission of Info0. No reaction to incoming infos. RES is an unconditional command.
Send Single Pulses	SSP	0010	Send Single Pulses.
Send Continuous Pulses	SCP	0011	Send Continuous Pulses.
Receiver not Synchronous	RSY	0100	Receiver is not synchronous
Activation Request	AR	1000	Activation Request. This command is used to start an exchange initiated activation.
Activation Request Loop	ARL	1010	Activation request loop. The transceiver is requested to operate an analog loop-back close to the S/T-interface.
Activation Indication	AI	1100	Synchronous receiver, i.e. activation completed.

Description of Functional Blocks

Command	Abbr.	Code	Remark
Activation Indication Loop	AIL	1110	Activation Indication Loop
Deactivation Confirmation	DC	1111	Deactivation Confirmation. Transfers the transceiver into a deactivated state in which it can be activated from a terminal (detection of $\overline{\text{INFO 0}}$ enabled).

Indication	Abbr.	Code	Remark
Timing	TIM	0000	Interim indication during deactivation procedure
Receiver not Synchronous	RSY	0100	Receiver is not synchronous
Activation Request	AR	1000	$\overline{\text{INFO 0}}$ received from terminal. Activation proceeds.
Illegal Code Ciolation	CVR	1011	Illegal code violation received. This function has to be enabled in TR_CONF0.EN_ICV.
Activation Indication	AI	1100	Synchronous receiver, i.e. activation completed.
Deactivation Indication	DI	1111	Timer (32 ms) expired or $\overline{\text{INFO 0}}$ received for a duration of 16 ms after deactivation request

Description of Functional Blocks
3.5.4 Command/ Indicate Channel Codes (C/I0) - Overview

The table below presents all defined C/I0 codes. A command needs to be applied continuously until the desired action has been initiated. Indications are strictly state orientated. Refer to the state diagrams in the previous sections for commands and indications applicable in various states.

Code	TE/LT-T		LT-S		NT	
	Cmd	Ind	Cmd	Ind	Cmd	Ind
0 0 0 0	TIM	DR	DR	TIM	DR	TIM
0 0 0 1	RES	RES	RES	–	RES	–
0 0 1 0	SSP	TMA	SSP	–	SSP	–
0 0 1 1	SCP	SLD	SCP	–	SCP	–
0 1 0 0	–	RSY	–	RSY	RSY	RSY
0 1 0 1	–	DR6	–	–	–	–
0 1 1 0	–	–	–	–	–	–
0 1 1 1	–	PU	–	–	–	–
1 0 0 0	AR8	AR	AR	AR	AR	AR
1 0 0 1	AR10	–	–	–	–	–
1 0 1 0	ARL	ARL	ARL	–	ARL	–
1 0 1 1	–	CVR	–	CVR	–	CVR
1 1 0 0	–	AI8	–	AI	AI	AI
1 1 0 1	–	AI10	–	–	–	–
1 1 1 0	–	AIL	–	–	AIL	–
1 1 1 1	DI	DC	DC	DI	DC	DI

3.6 Control Procedures

3.6.1 Example of Activation/Deactivation

An example of an activation/deactivation of the S/T interface initiated by the terminal with the time relationships mentioned in the previous chapters is shown in **Figure 43**.

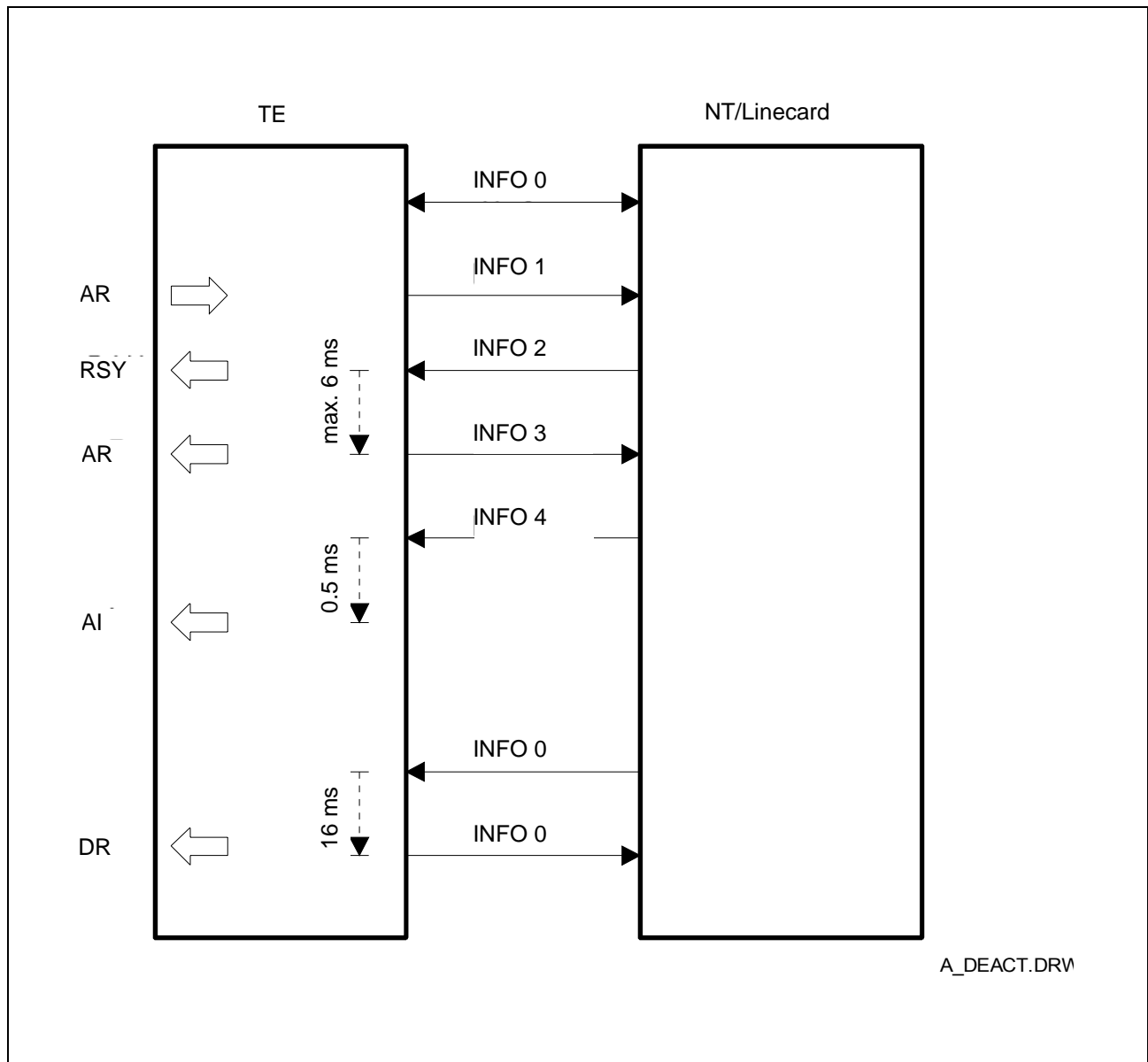

Figure 43 Example of Activation/Deactivation Initiated by the Terminal

3.6.2 Activation initiated by the Terminal

INFO 1 has to be transmitted as long as INFO 0 is received.

INFO 0 has to be transmitted thereafter as long as no valid INFO (INFO 2 or INFO 4) is received.

After reception of INFO 2 or INFO 4 transmission of INFO 3 has to be started.

Data can be transmitted if INFO 4 has been received.

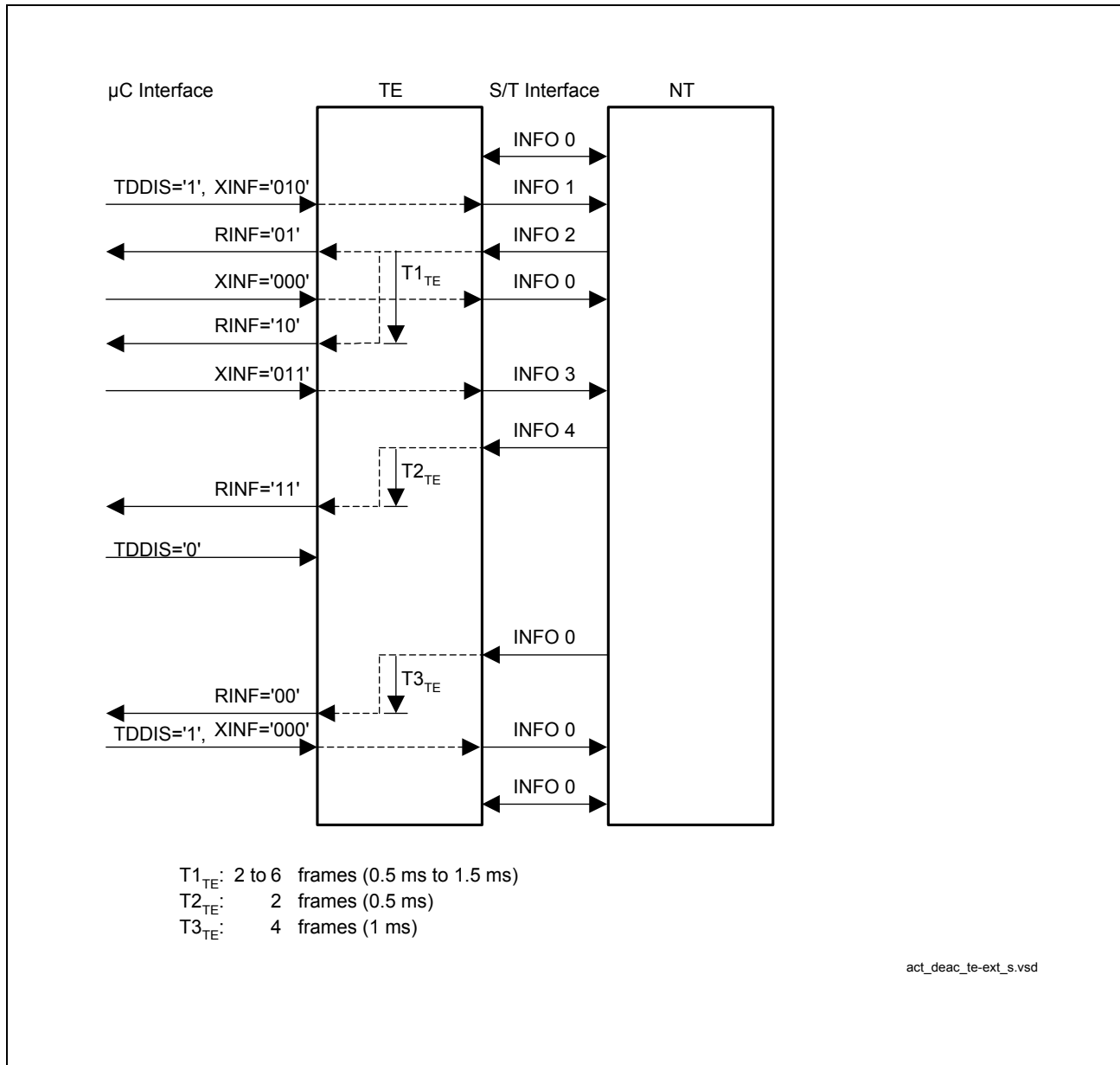
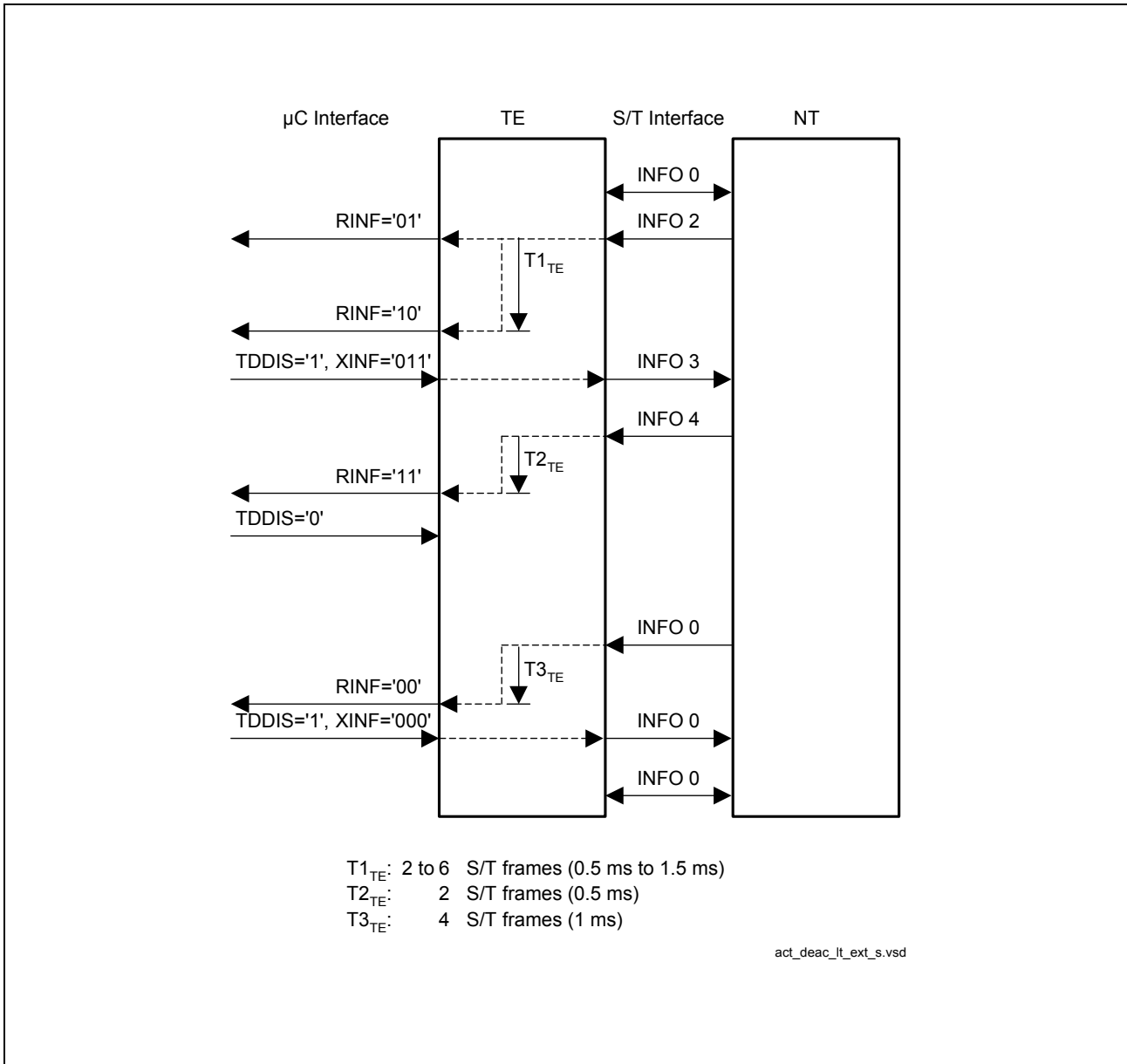

**Figure 44 Example of Activation/Deactivation initiated by the Terminal (TE).
Activation/Deactivation completely under Software Control**

Note: RINF and XINF are Receive- and Transmit-INFOs of register TR_STA.

3.6.3 Activation initiated by the Network Termination NT

INFO 0 has to be transmitted as long as no valid INFO (INFO 2 or INFO 4) is received. After reception of INFO 2 or INFO 4 transmission of INFO 3 has to be started. Data can be transmitted if INFO 4 has been received.



**Figure 45 Example of Activation/Deactivation initiated by the Network Termination (NT).
Activation/Deactivation completely under Software Control**

Note: RINF and XINF are Receive- and Transmit-INFOs of register TR_STA.

3.7 IOM-2 Interface

The ISAC-SX supports the IOM-2 interface in linecard mode and in terminal mode with single clock and double clock. The IOM-2 interface consists of four lines: FSC, DCL, DD and DU. The rising edge of FSC indicates the start of an IOM-2 frame. The DCL and the BCL clock signals synchronize the data transfer on both data lines DU and DD. The DCL is twice the bit rate, the BCL rate is equal to the bit rate. The bits are shifted out with the rising edge of the first DCL clock cycle and sampled at the falling edge of the second clock cycle.

The IOM-2 interface can be enabled/disabled with the DIS_IOM bit in the IOM_CR register.

TE Mode

A DCL signal and BCL signal (pin BCL/SCLK) output is provided and the FSC signal is generated by the receive DPLL which synchronizes it to the received S/T frame.

The BCL clock together with the two serial data strobe signals (SDS1, SDS2) can be used to connect time slot oriented standard devices to the IOM-2 interface. If the transceiver is disabled (TR_CON.DIS_TR) the DCL and FSC pins become input and the HDLC part can still work via IOM-2. In this case the clock mode bit (IOM_CR.CLKM) selects between a double clock and a single clock input for DCL.

The clock rate/frequency of the IOM-2 signals in TE mode are:

DD, DU: 768 kbit/s
 FSC (o): 8 kHz
 DCL (o): 1536 kHz (double clock rate)
 BCL (o): 768 kHz (single clock rate)
 Option - Transceiver disabled (DIS_TR = '1'):
 FSC (i): 8 kHz
 DCL (i): 1536 ... 4096 kHz, in steps of 512 kHz (double clock rate)

LT-S, LT-T, NT, iNT Mode

The IOM-2 clock signals FSC and BCL are input.

In LT-T mode a 1536 kHz output clock synchronous to S is provided at pin SCLK which can directly be connected to the DCL input. Internal clock dividers provide for generation of an FSC or BCL output clock at pin FBOUT derived from DCL (see [Chapter 3.4](#)).

DD, DU: data rate = DCL/2 kbit/s (LT-T mode)
 FSC (i): 8 kHz
 DCL (i): 512 ... 4096 kHz, in steps of 512 kHz (double clock rate)
 SCLK (o): 1536 kHz (LT-T mode), BCL derived via DCL/2 (LT-S/NT mode)

Note: In all modes the direction of the data lines DU and DD is not fix but depending on the timeslot which can be seen in the figures below.

IOM-2 Frame Structure (TE Mode)

The frame structure on the IOM-2 data ports (DU,DD) of a master device in IOM-2 terminal mode is shown in [Figure 46](#).

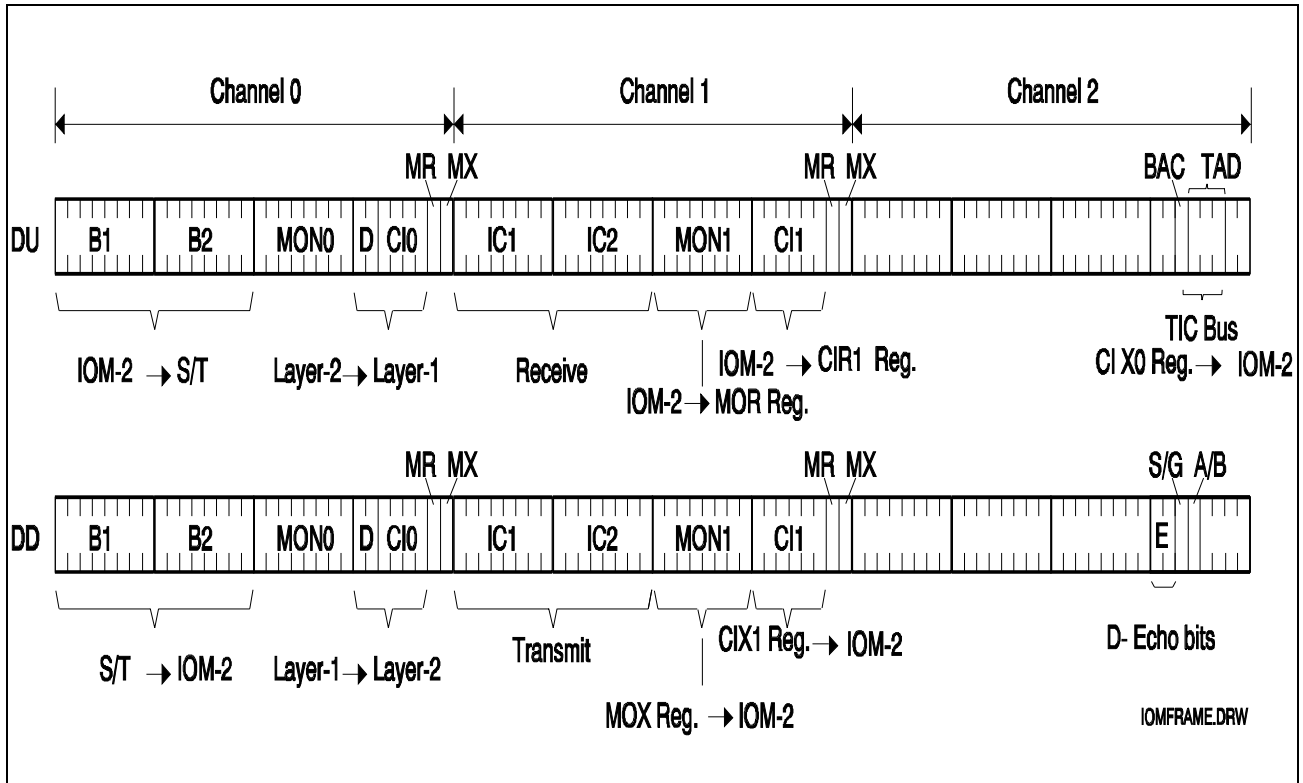

Figure 46 IOM[®]-2 Frame Structure in Terminal Mode

The frame is composed of three channels

- Channel 0 contains 144-kbit/s of user and signaling data (2B + D), a MONITOR programming channel (MON0) and a command/indication channel (C10) for control and programming of the layer-1 transceiver.
- Channel 1 contains two 64-kbit/s intercommunication channels (IC) plus a MONITOR and command/indicate channel (MON1, C11) to program or transfer data to other IOM-2 devices.
- Channel 2 is used for the TIC-bus access. Only the command/indicate bits are specified in this channel.

IOM-2 Frame Structure (LT-S, LT-T Modes)

This mode is used in LT-S and LT-T applications. The frame is a multiplex of up to eight IOM-2 channels (DCL = 4096 kHz, [Figure 47](#)), each of which has the structure described above.

The reset value for assignment to one of the eight channels (0 to 7) is done via pin strapping (CH0-2), however the host can reprogram the selected timeslot in DCH_TSDP.TSS.

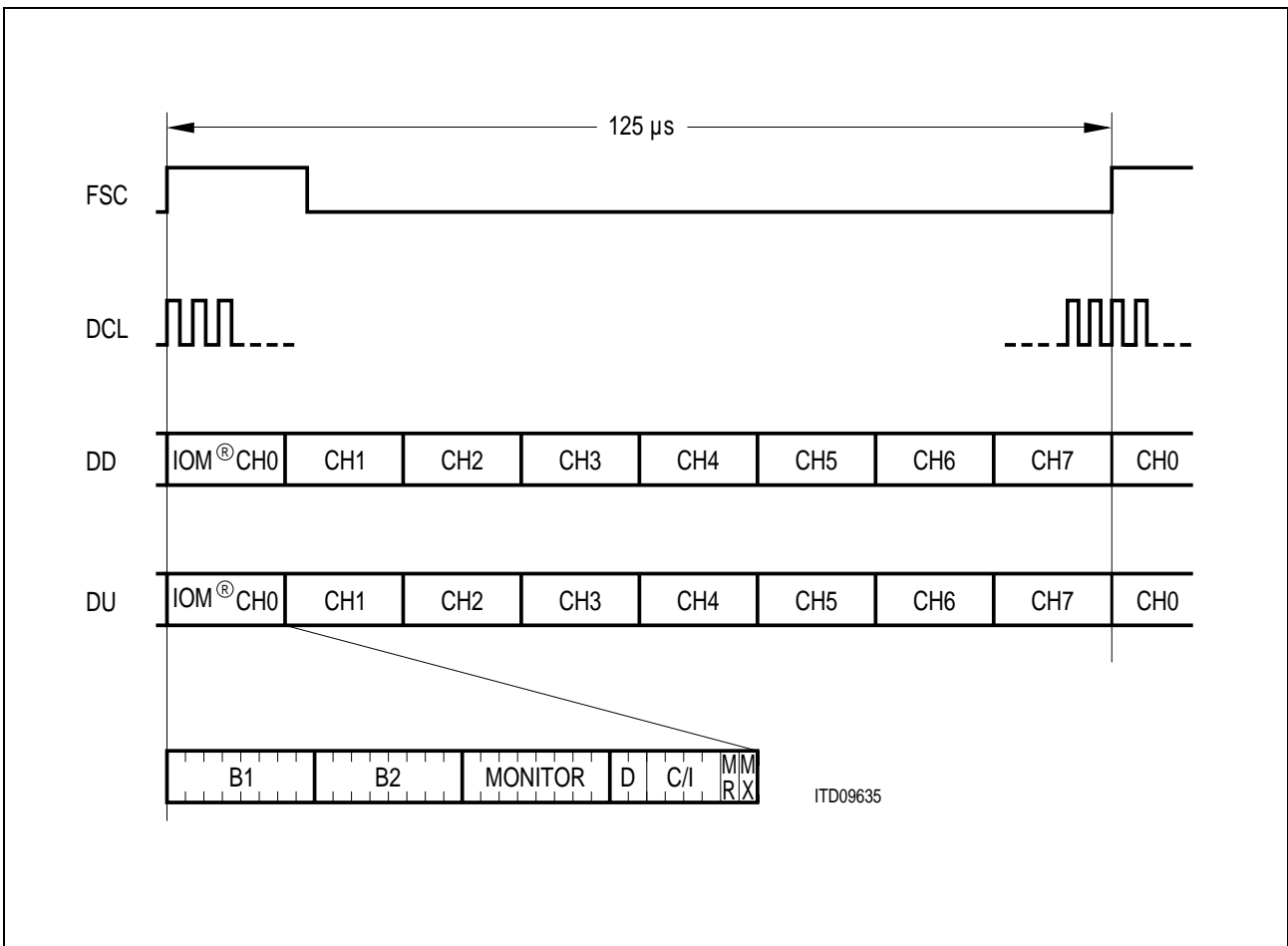

Figure 47 Multiplexed Frame Structure of the IOM-2 Interface in Non-TE Timing Mode

IOM-2 Frame Structure (NT Mode)

In NT mode one IOM-2 channel is used (DCL= 512 kHz). The channel structure is the same as described above.

3.7.1 IOM-2 Handler

The IOM-2 handler offers a great flexibility for handling the data transfer between the different functional units of the ISAC-SX and voice/data devices connected to the IOM-2 interface. Additionally it provides a microcontroller access to all timeslots of the IOM-2 interface via the four controller data access registers (CDA). **Figure 48** shows the architecture of the IOM-2 handler. For illustrating the functional description it contains all configuration and control registers of the IOM-2 handler. A detailed register description can be found in **Chapter 4.4**.

The PCM data of the functional units

- Transceiver (TR) and the
- Controller data access (CDA)
- B-channel HDLC controller

can be configured by programming the time slot and data port selection registers (TSDP). With the TSS bits (Time Slot Selection) the PCM data of the functional units can be assigned to each of the 32 PCM time slots of the IOM-2 frame. With the DPS bit (Data Port Selection) the output of each functional unit is assigned to DU or DD respectively. The input is assigned vice versa. With the data control registers (xxx_CR) the access to the data of the functional units can be controlled by setting the corresponding control bits (EN, SWAP).

The IOM-2 handler also provides access to the

- MONITOR channel (MON)
- C/I channels (C/I0,C/I1)
- TIC bus (TIC) and
- HDLC control

The access to these channels is controlled by the registers MON_CR, DCI_CR and BCH_CR.

The IOM-2 interface with the two Serial Data Stobes (SDS1,2) is controlled by the control registers IOM_CR, SDS1_CR and SDS2_CR.

The reset configuration of the ISAC-SX IOM-2 handler corresponds to the defined frame structure and data ports of a master device in IOM-2 terminal mode (see **Figure 46**).

Description of Functional Blocks

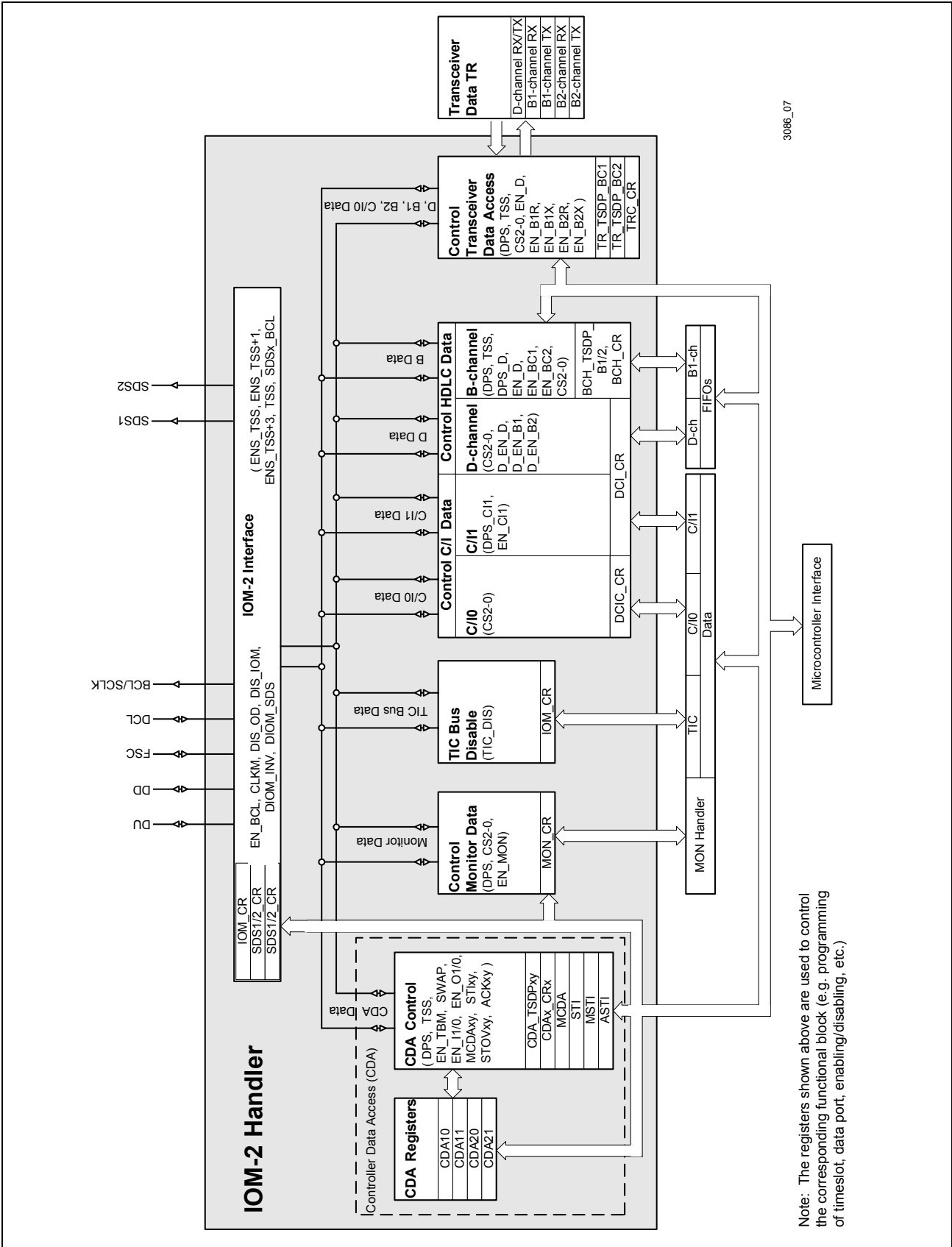

3086_07

Figure 48 Architecture of the IOM Handler (Example Configuration)

3.7.1.1 Controller Data Access (CDA)

With its four controller data access registers (CDA10, CDA11, CDA20, CDA21) the ISAC-SX IOM-2 handler provides a very flexible solution for the host access to up to 32 IOM-2 time slots.

The functional unit CDA (controller data access) allows with its control and configuration registers

- looping of up to four independent PCM channels from DU to DD or vice versa over the four CDA registers
- shifting of two independent PCM channels to another two independent PCM channels on both data ports (DU, DD). Between reading and writing the data can be manipulated (processed with an algorithm) by the microcontroller. If this is not the case a switching function is performed
- monitoring of up to four time slots on the IOM-2 interface simultaneously
- microcontroller read and write access to each PCM timeslot

The access principle which is identical for the two channel register pairs CDA10/11 and CDA20/21 is illustrated in **Figure 49**. Each of the index variables x,y used in the following description can be 1 or 2 for x and 0 or 1 for y. The prefix 'CDA_' from the register names has been omitted for simplification.

To each of the four CDAXy data registers a TSDPxy register is assigned by which the time slot and the data port can be determined. With the TSS (Time Slot Selection) bits a time slot from 0...31 can be selected. With the DPS (Data Port Selection) bit the output of the CDAXy register can be assigned to DU or DD respectively. The time slot and data port for the output of CDAXy is always defined by its own TSDPxy register. The input of CDAXy depends on the SWAP bit in the control registers CRx.

- If the SWAP bit = '0' (swap is disabled) the time slot and data port for the input and output of the CDAXy register is defined by its own TSDPxy register.
- If the SWAP bit = '1' (swap is enabled) the input port and timeslot of the CDAX0 is defined by the TSDP register of CDAX1 and the input port and timeslot of CDAX1 is defined by the TSDP register of CDAX0. The input definition for timeslot and data port CDAX0 are thus swapped to CDAX1 and for CDAX1 swapped to CDAX0. The output timeslots are not affected by SWAP.

The input and output of every CDAXy register can be enabled or disabled by setting the corresponding EN (-able) bit in the control register CDAX_CR. If the input of a register is disabled the output value in the register is retained.

Usually one input and one output of a functional unit (transceiver, HDLC controller, CDA register) is programmed to a timeslot on IOM-2 (e.g. for B-channel transmission in upstream direction the HDLC controller writes data onto IOM and the transceiver reads data from IOM). For monitoring data in such cases a CDA register is programmed as described below under "Monitoring Data". Besides that none of the IOM timeslots must be assigned more than one input and output of any functional unit.

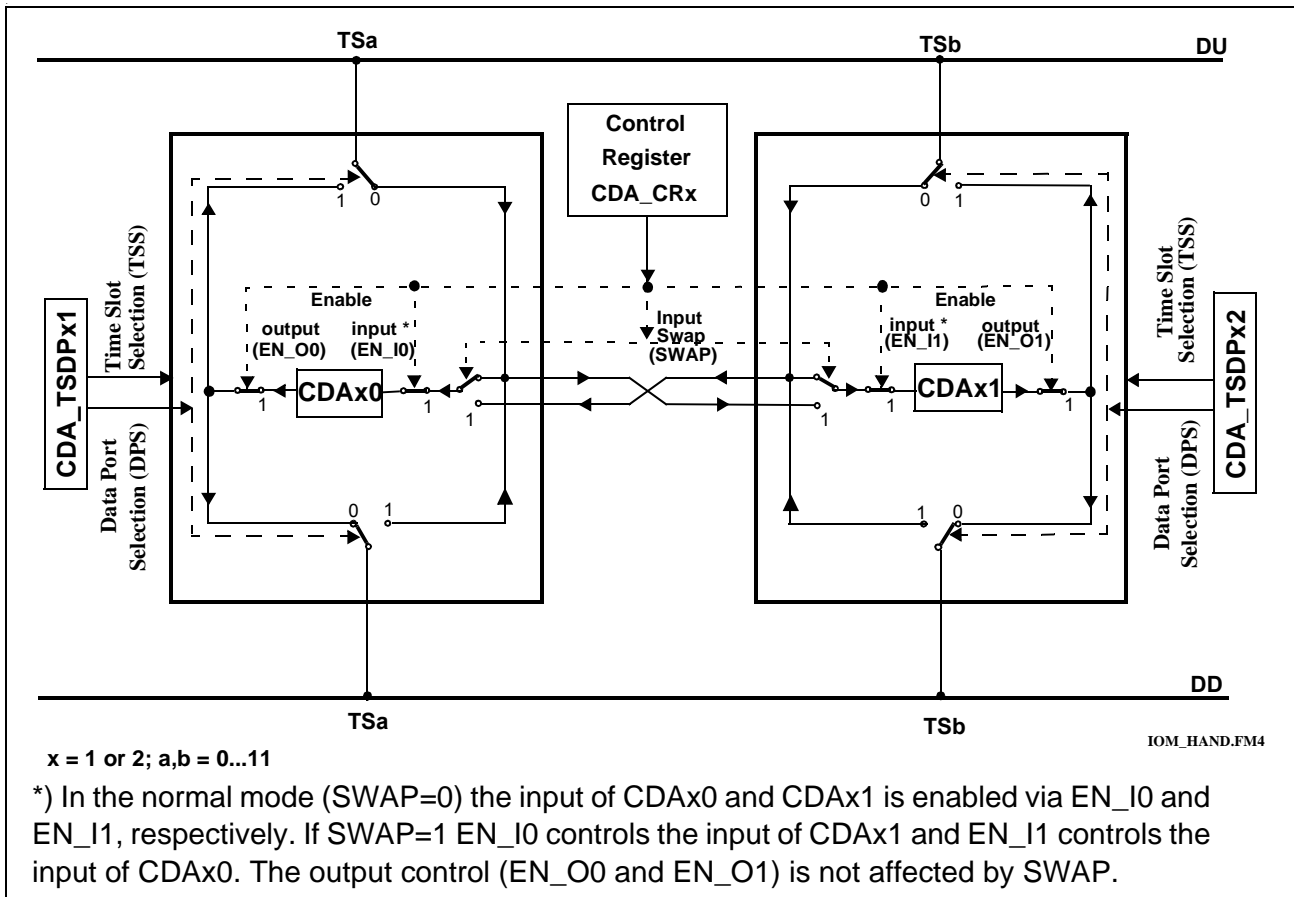

Figure 49 Data Access via CDAX1 and CDAX2 register pairs

Looping and Shifting Data

Figure 50 gives examples for typical configurations with the above explained control and configuration possibilities with the bits TSS, DPS, EN and SWAP in the registers TSDPxy or CDAX_CR:

- looping IOM-2 time slot data from DU to DD or vice versa (SWAP = 0)
- shifting data from TSa to TSb and TSc to TSd in both transmission directions (SWAP = 1)
- switching data from TSa to TSb and looping from DU to DD or TSc to TSd and looping from DD to DU respectively

TSa is programmed in TSDP10, TSb in TSDP11, TSc in TSDP20 and TSd in TSDP21. It should also be noted that the input control of CDA registers is swapped if SWAP=1 while the output control is not affected (e.g. for CDA11 in example a: EN_I1=1 and EN_O1=1, whereas for CDA11 in example b: EN_I0=1 and EN_O1=1).

Description of Functional Blocks

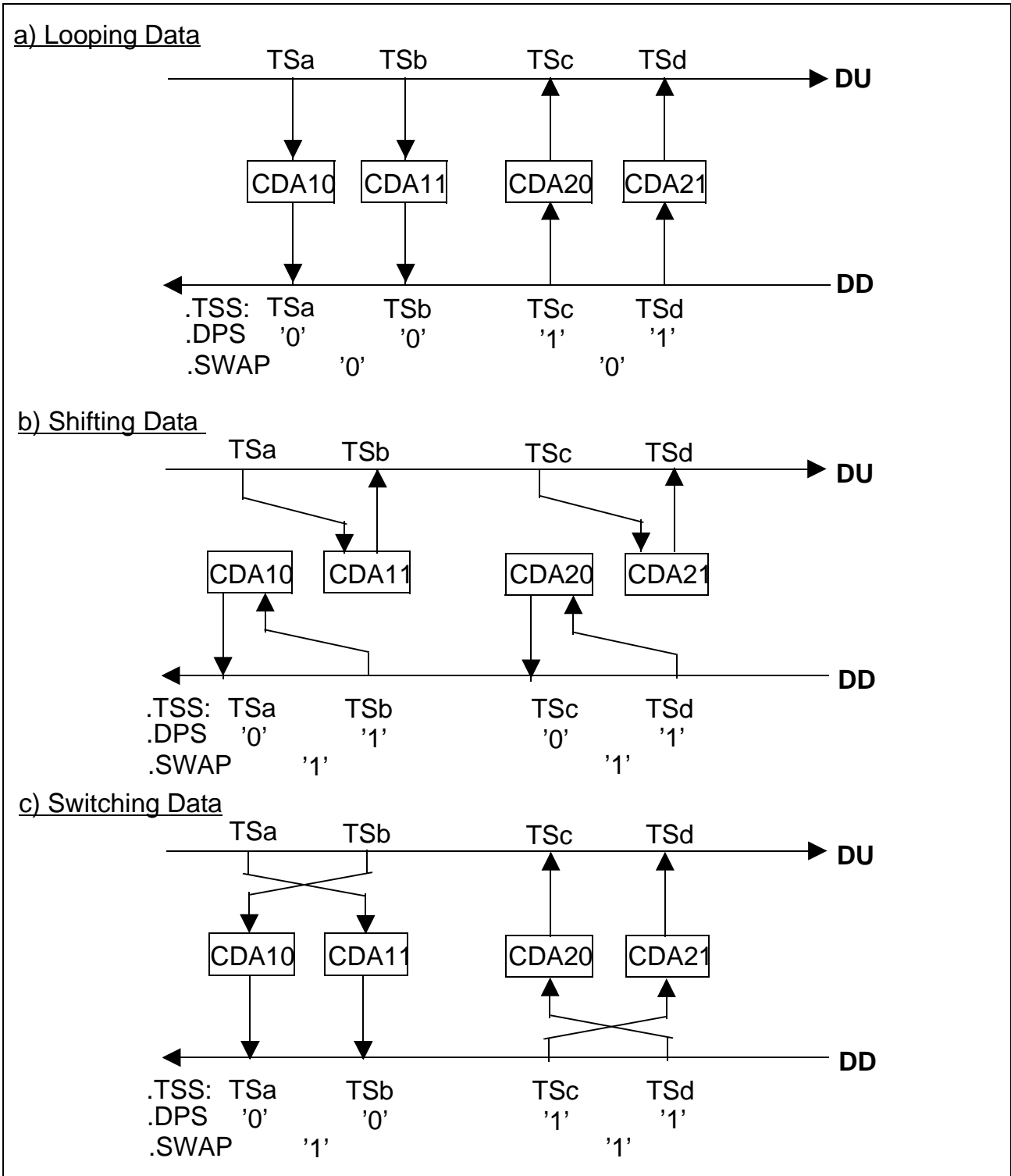

Figure 50 Examples for Data Access via CDAxy Registers

- a) Looping Data
- b) Shifting (Switching) Data
- c) Switching and Looping Data

Description of Functional Blocks

Figure 51 shows the timing of looping TSa from DU to DD (a = 0...11) via CDAXy register. TSa is read in the CDAXy register from DU and is written one frame later on DD.

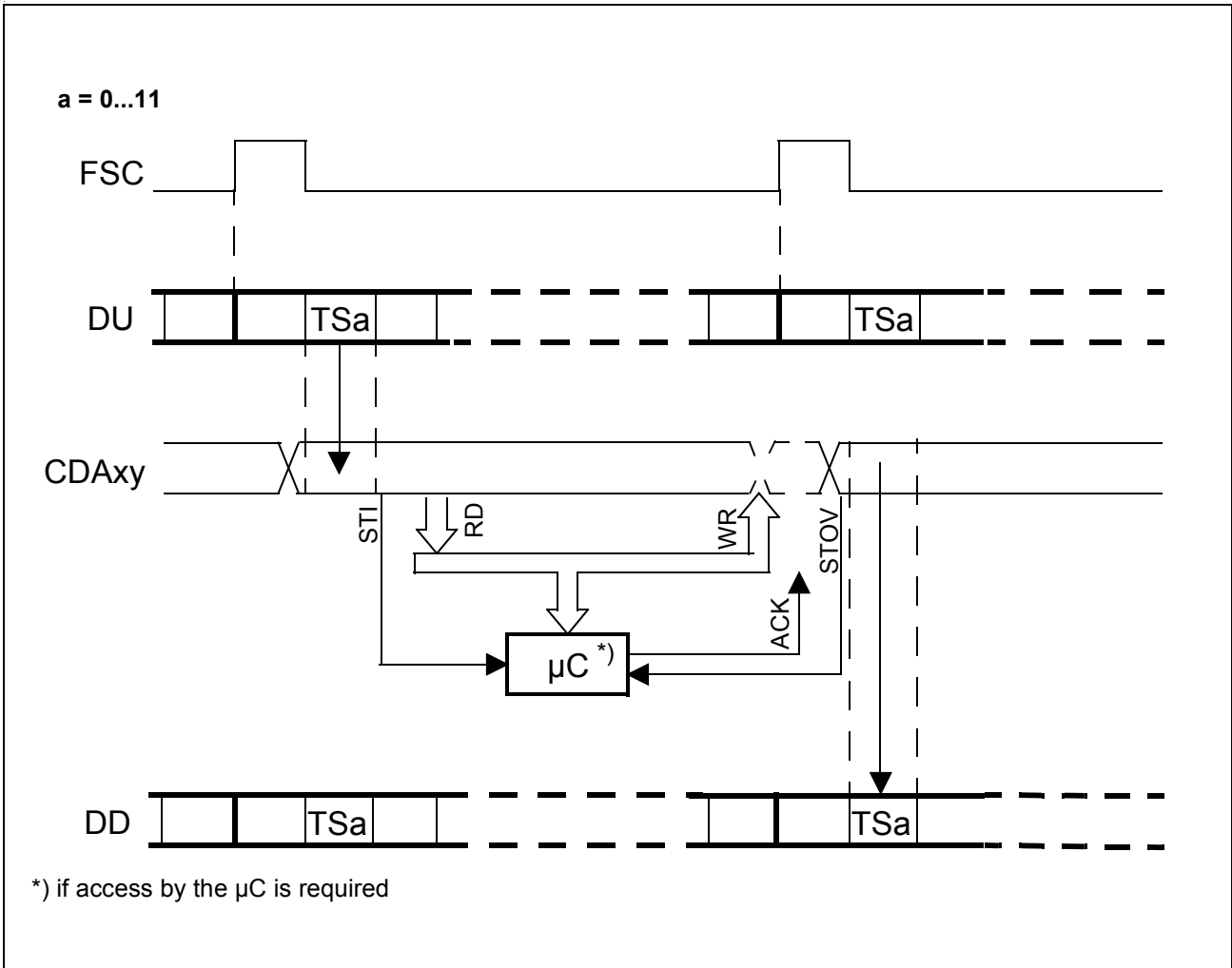

Figure 51 Data Access when Looping TSa from DU to DD

Figure 52 shows the timing of shifting data from TSa to TSb on DU (DD). In Figure 52a) shifting is done in one frame because TSa and TSb didn't succeed direct one another (a, b = 0...9 and $b \geq a+2$). In Figure 52b) shifting is done from one frame to the following frame. This is the case when the time slots succeed one other ($b = a+1$) or b is smaller than a ($b < a$).

At looping and shifting the data can be accessed by the controller between the synchronous transfer interrupt (STI) and the status overflow interrupt (STOV). STI and STOV are explained in the section 'Synchronous Transfer'. If there is no controller intervention the looping and shifting is done autonomous.

Description of Functional Blocks

a) Shifting TSa → TSb within one frame
(a,b: 0...11 and $b \geq a+2$)

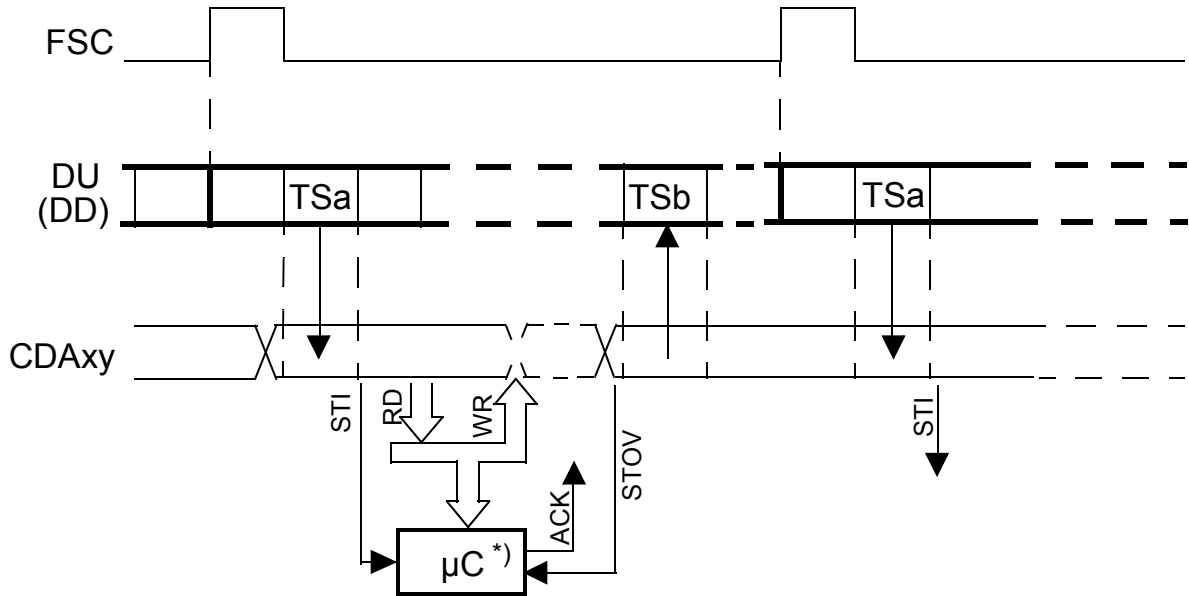

b) Shifting TSa → TSb in the next frame
(a,b: 0...11 and ($b = a+1$ or $b < a$))

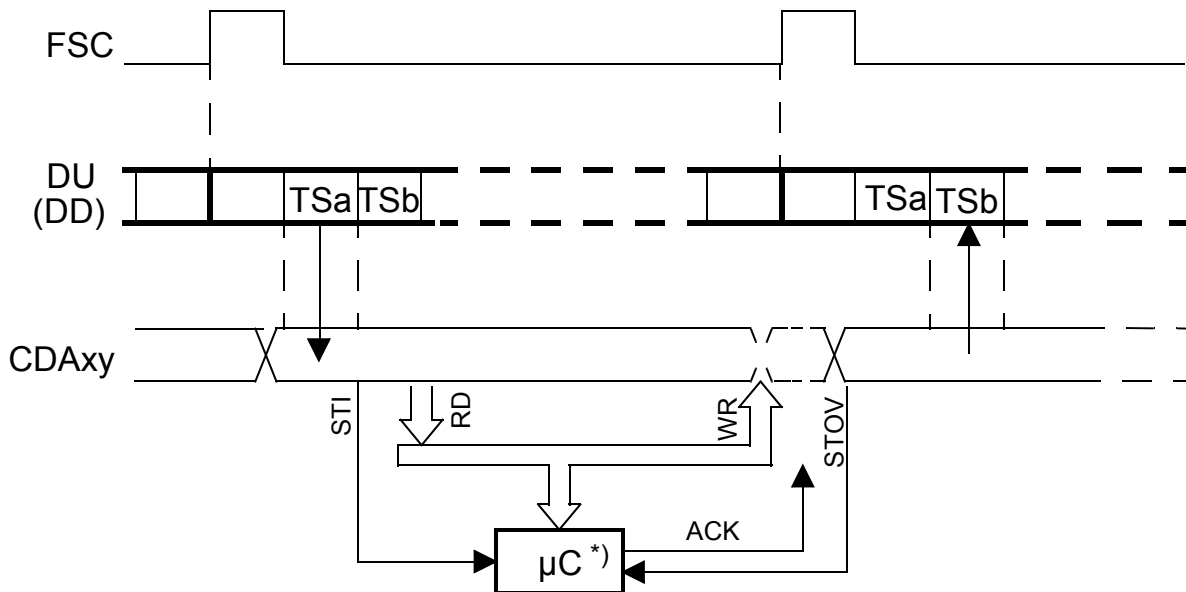

*) if access by the µC is required

Figure 52 Data Access when Shifting TSa to TSb on DU (DD)

Monitoring Data

Figure 53 gives an example for monitoring of two IOM-2 time slots each on DU or DD simultaneously. For monitoring on DU and/or DD the channel registers with even numbers (CDA10, CDA20) are assigned to time slots with even numbers TS(2n) and the channel registers with odd numbers (CDA11, CDA21) are assigned to time slots with odd numbers TS(2n+1). The user has to take care of this restriction by programming the appropriate time slots..

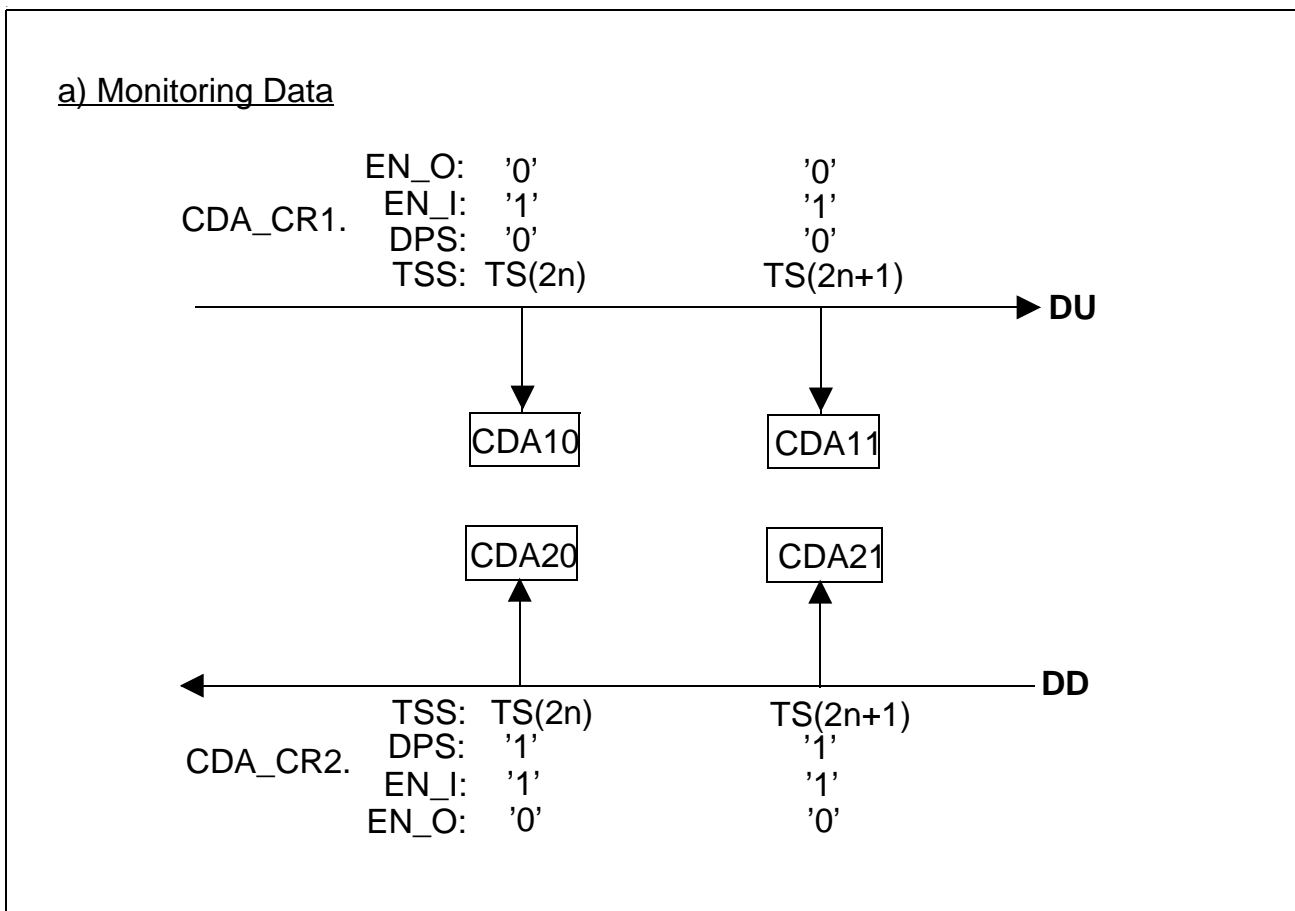

Figure 53 Example for Monitoring Data

Monitoring TIC Bus

Monitoring the TIC bus (TS11) is handled as a special case. The TIC bus can be monitored with the registers CDAX0 by setting the EN_TBM (Enable TIC Bus Monitoring) bit in the control registers CRx. In this special case the TSDPx0 must be set to 08_h for monitoring from DU or 88_h for monitoring from DD respectively. By this it is possible to monitor the TIC bus (TS11) and the odd numbered D-channel (TS3) simultaneously on DU and DD.

Description of Functional Blocks**Synchronous Transfer**

While looping, shifting and switching the data can be accessed by the controller between the synchronous transfer interrupt (STI) and the status overflow interrupt (STOV).

The microcontroller access to the CDA_{xy} registers can be synchronized by means of four programmable synchronous transfer interrupts (STI_{xy})¹⁾ and synchronous transfer overflow interrupts (STOV_{xy})²⁾ in the STI register.

Depending on the DPS bit in the corresponding CDA_TSDP_{xy} register the STI_{xy} is generated two (for DPS='0') or one (for DPS='1') BCL clock after the selected time slot (CDA_TSDP_{xy}.TSS). One BCL clock is equivalent to two DCL clocks.

In the following description the index xy_0 and xy_1 are used to refer to two different interrupt pairs (STI/STOV) out of the four CDA interrupt pairs (STI10/STOV10, STI11/STOV11, STI20/STOV20, STI21/STOV21).

An STOV_{xy₀} is related to its STI_{xy₀} and is only generated if STI_{xy₀} is enabled and not acknowledged. However, if STI_{xy₀} is masked, the STOV_{xy₀} is generated for any other STI_{xy₁} which is enabled and not acknowledged.

Table 10 gives some examples for that. It is assumed that an STOV interrupt is only generated because an STI interrupt was not acknowledged before.

In example 1 only the STI_{xy₀} is enabled and thus STI_{xy₀} is only generated. If no STI is enabled, no interrupt will be generated even if STOV is enabled (example 2).

In example 3 STI_{xy₀} is enabled and generated and the corresponding STOV_{xy₀} is disabled. STI_{xy₁} is disabled but its STOV_{xy₁} is enabled, and therefore STOV_{xy₁} is generated due to STI_{xy₀}. In example 4 additionally the corresponding STOV_{xy₀} is enabled, so STOV_{xy₀} and STOV_{xy₁} are both generated due to STI_{xy₀}.

In example 5 additionally the STI_{xy₁} is enabled with the result that STOV_{xy₀} is only generated due to STI_{xy₀} and STOV_{xy₁} is only generated due to STI_{xy₁}.

Compared to the previous example STOV_{xy₀} is disabled in example 6, so STOV_{xy₀} is not generated and STOV_{xy₁} is only generated for STI_{xy₁} but not for STI_{xy₀}.

Compared to example 5 in example 7 a third STOV_{xy₂} is enabled and thus STOV_{xy₂} is generated additionally for both STI_{xy₀} and STI_{xy₁}.

1) In order to enable the STI interrupts the input of the corresponding CDA register has to be enabled. This is also valid if only a synchronous write access is wanted. The enabling of the output alone does not effect an STI interrupt.

2) In order to enable the STOV interrupts the output of the corresponding CDA register has to be enabled. This is also valid if only a synchronous read access is wanted. The enabling of the input alone does not effect an interrupt.

Description of Functional Blocks

Table 10 Examples for Synchronous Transfer Interrupts

Enabled Interrupts (Register MSTI)		Generated Interrupts (Register STI)		
STI	STOV	STI	STOV	
xy ₀	-	xy ₀	-	Example 1
-	xy ₀	-	-	Example 2
xy ₀	xy ₁	xy ₀	xy ₁	Example 3
xy ₀	xy ₀ ; xy ₁	xy ₀	xy ₀ ; xy ₁	Example 4
xy ₀ ; xy ₁	xy ₀ ; xy ₁	xy ₀ xy ₁	xy ₀ xy ₁	Example 5
xy ₀ ; xy ₁	xy ₁	xy ₀ xy ₁	- xy ₁	Example 6
xy ₀ ; xy ₁	xy ₀ ; xy ₁ ; xy ₂	xy ₀ xy ₁	xy ₀ ; xy ₂ xy ₁ ; xy ₂	Example 7

An STOV interrupt is not generated if all stimulating STI interrupts are acknowledged.

An STI_{xy} must be acknowledged by setting the ACK_{xy} bit in the ASTI register until two BCL clocks (for DPS='0') or one BCL clocks (for DPS='1') before the time slot which is selected for the appropriate STI_{xy}.

The interrupt structure of the synchronous transfer is shown in [Figure 54](#).

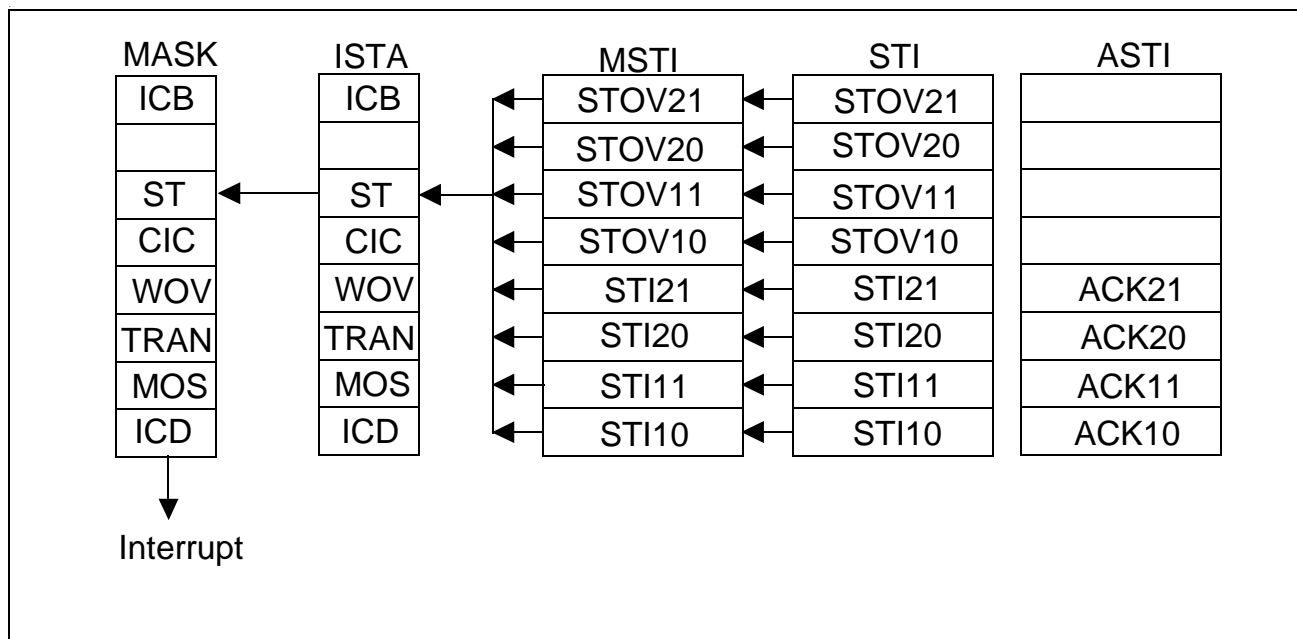

Figure 54 Interrupt Structure of the Synchronous Data Transfer

Description of Functional Blocks

Figure 55 shows some examples based on the timeslot structure. Figure a) shows at which point in time an STI and STOV interrupt is generated for a specific timeslot. Figure b) is identical to example 3 above, figure c) corresponds to example 5 and figure d) shows example 4.

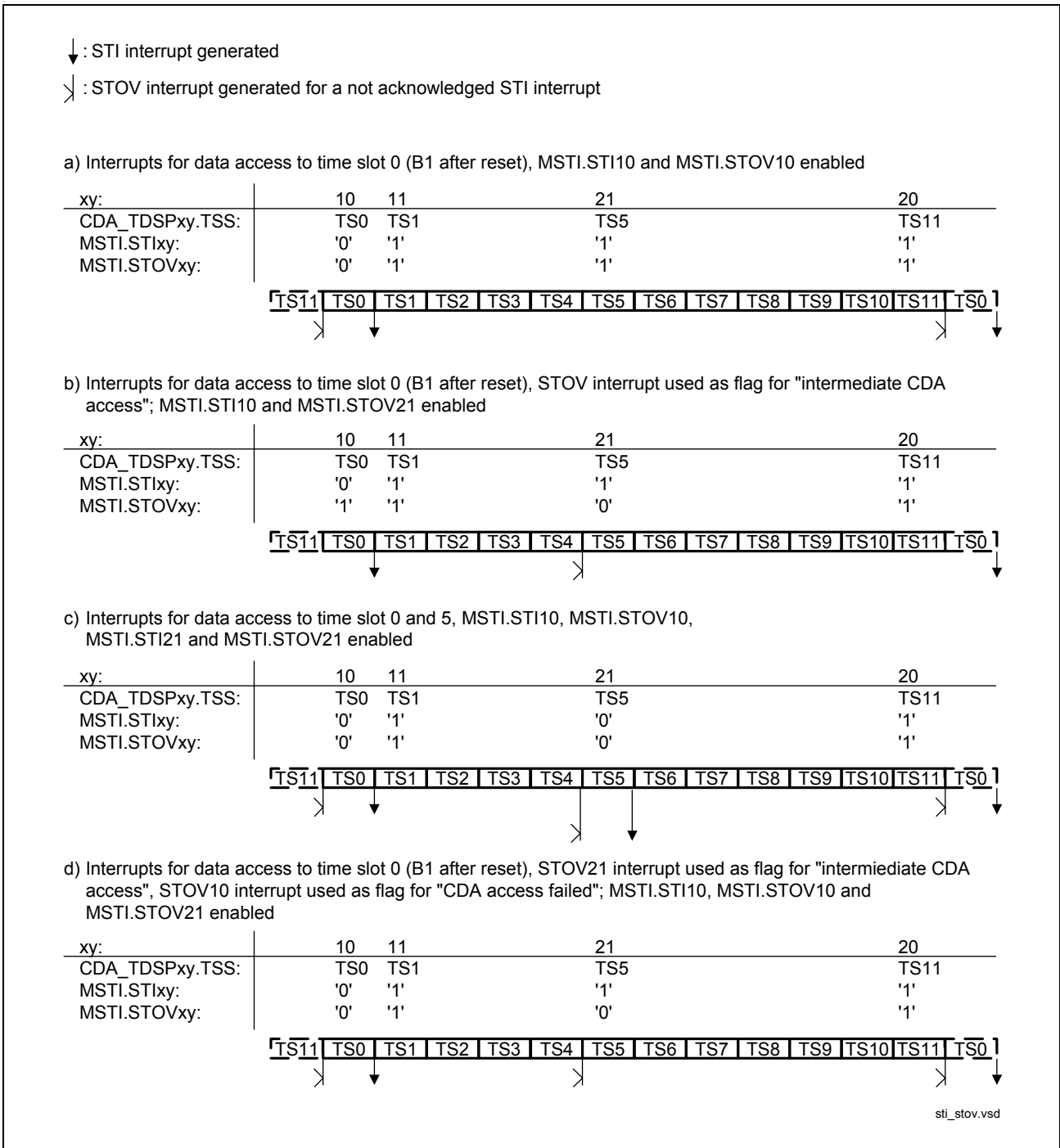

Figure 55 Examples for the Synchronous Transfer Interrupt Control with one enabled STIxy

Description of Functional Blocks

Restrictions Concerning Monitoring and Shifting Data

Due to the hardware design, there are some restrictions for the CDA shifting data function and for the CDA monitoring data function. The selection of the CDA registers is restricted if other functional blocks of the ISAC-SX (transceiver cores, HDLC controllers, CI handler, Monitor handler, TIC bus etc.) access the corresponding timeslot.

If no functional block is assigned to a certain timeslot, any CDA register can be used for monitoring or shifting it.

If a timeslot is already occupied by a functional block in a certain transmission direction, only CDA registers with odd numbers (CDA11/21) can be assigned to odd timeslots and CDA registers with even numbers (CDA10/20) can be assigned to even timeslots in the same transmission direction. For the other transmission direction every CDA register can be used. (Example: If TS 5 is already occupied in DD direction, only CDA11 and 21 can be used for monitoring it. For monitoring TS 5 in DU direction, also CDA10 or CDA20 could be used.)

If above guideline is not considered, data can be overwritten in corresponding timeslots. In this context no general rules can be derived in which way the data are overwritten.

The usage of the looping data and switching data functions are unrestricted.

Restrictions Concerning Read/Write Access

If data shall be read out from a certain transmission direction and other data shall be written in the opposite transmission direction in the same timeslot, only special CDA register combinations can be used. The correct behavior can be achieved with the following CDA register combinations:

Table 11 CDA Register Combinations with Correct Read/Write Access

CDA Register Combination	1	2	3	4
Data of the downstream timeslot is read by	CDA10	CDA11	CDA20	CDA21
Data is written to the upstream timeslot from	CDA20	CDA21	CDA10	CDA11

With other register combinations unintended loops or erroneous monitorings can occur or wrong data is written to the IOM interface.

Unexpected Write/Read Behavior of CDA Registers

If inputs and outputs are disabled, the programmed values of CDA10/11/20/21 registers cannot be read back. Instead of the expected value the content of the previous programming can be read out. The programmed value (5A_H in the following example) will be fetched if the output is enabled.

Example:

w CDA1_CR = 00_H (inputs and outputs are disabled)
w CDA10 = 5A_H (example)
r CDA10 = FF_H (old value of previous programming)
w CDA1_CR = 02_H (output of CDA10 is enabled)
r CDA10 = 5A_H (the programmed value can be read back)

3.7.2 Serial Data Strobe Signal and Strobed Data Clock

For time slot oriented standard devices connected to the IOM-2 interface the ISAC-SX provides two independent data strobe signals SDS1 and SDS2. Instead of a data strobe signal a strobed IOM-2 bit clock can be provided on pin SDS1 and SDS2.

3.7.2.1 Serial Data Strobe Signal

The two strobe signals can be generated with every 8-kHz frame and are controlled by the registers SDS1/2_CR. By programming the TSS bits and three enable bits (ENS_TSS, ENS_TSS+1, ENS_TSS+3) a data strobe can be generated for the IOM-2 time slots TS, TS+1 and TS+3 and any combination of them.

The data strobes for TS and TS+1 are always 8 bits long (bit7 to bit0) whereas the data strobe for TS+3 is always 2 bits long (bit7, bit6).

Figure 56 shows three examples for the generation of a strobe signal. In example 1 the SDS is active during channel B2 on IOM-2 whereas in the second example during IC2 and MON1. The third example shows a strobe signal for 2B+D channels which can be used e.g. for an IDSL (144kbit/s) transmission.

Description of Functional Blocks

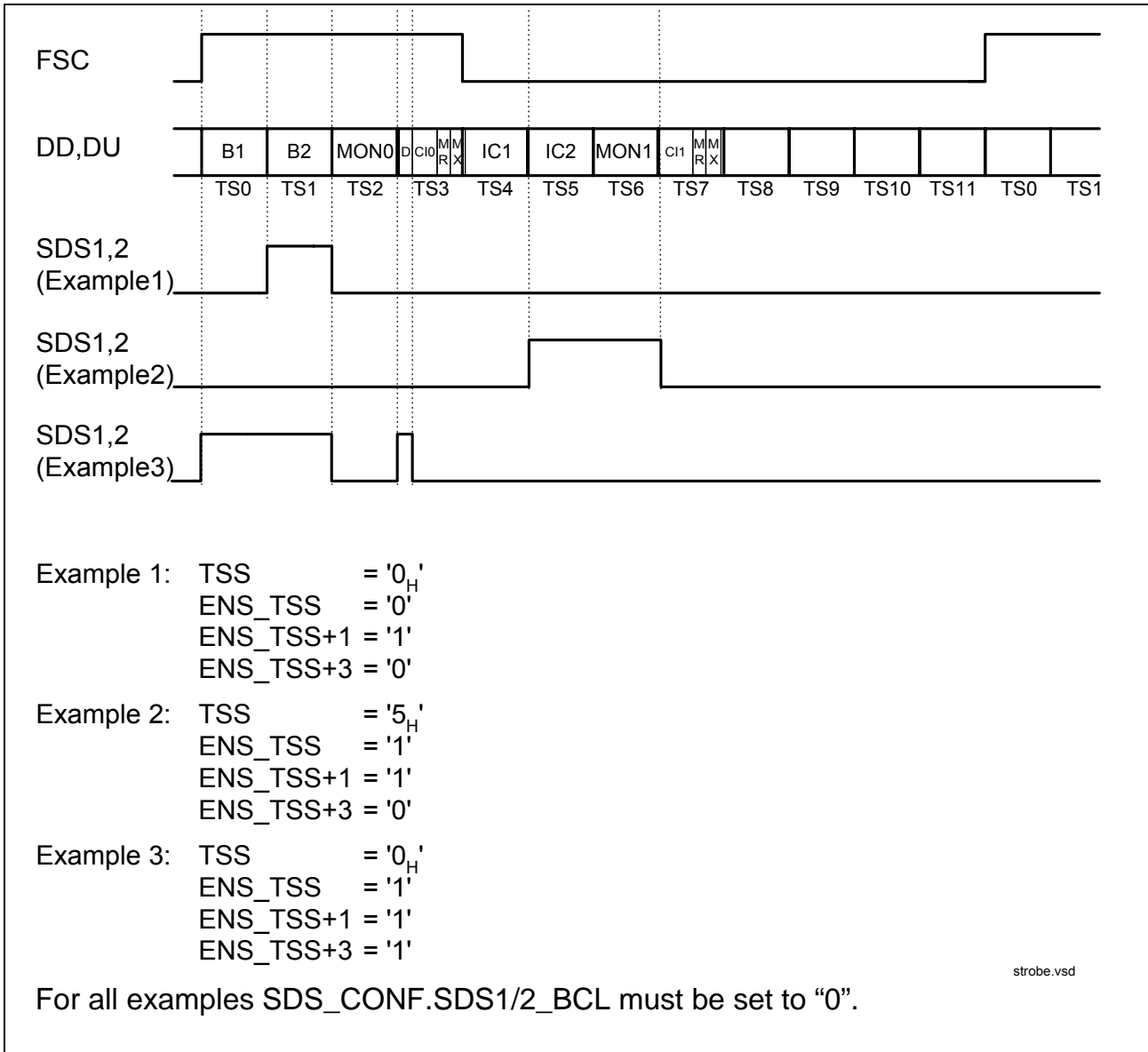

Figure 56 Data Strobe Signal

3.7.2.2 Strobed IOM-2 Bit Clock

The strobed IOM-2 bit clock is active during the programmed window. Outside the programmed window a '0' is driven. Two examples are shown in [Figure 57](#).

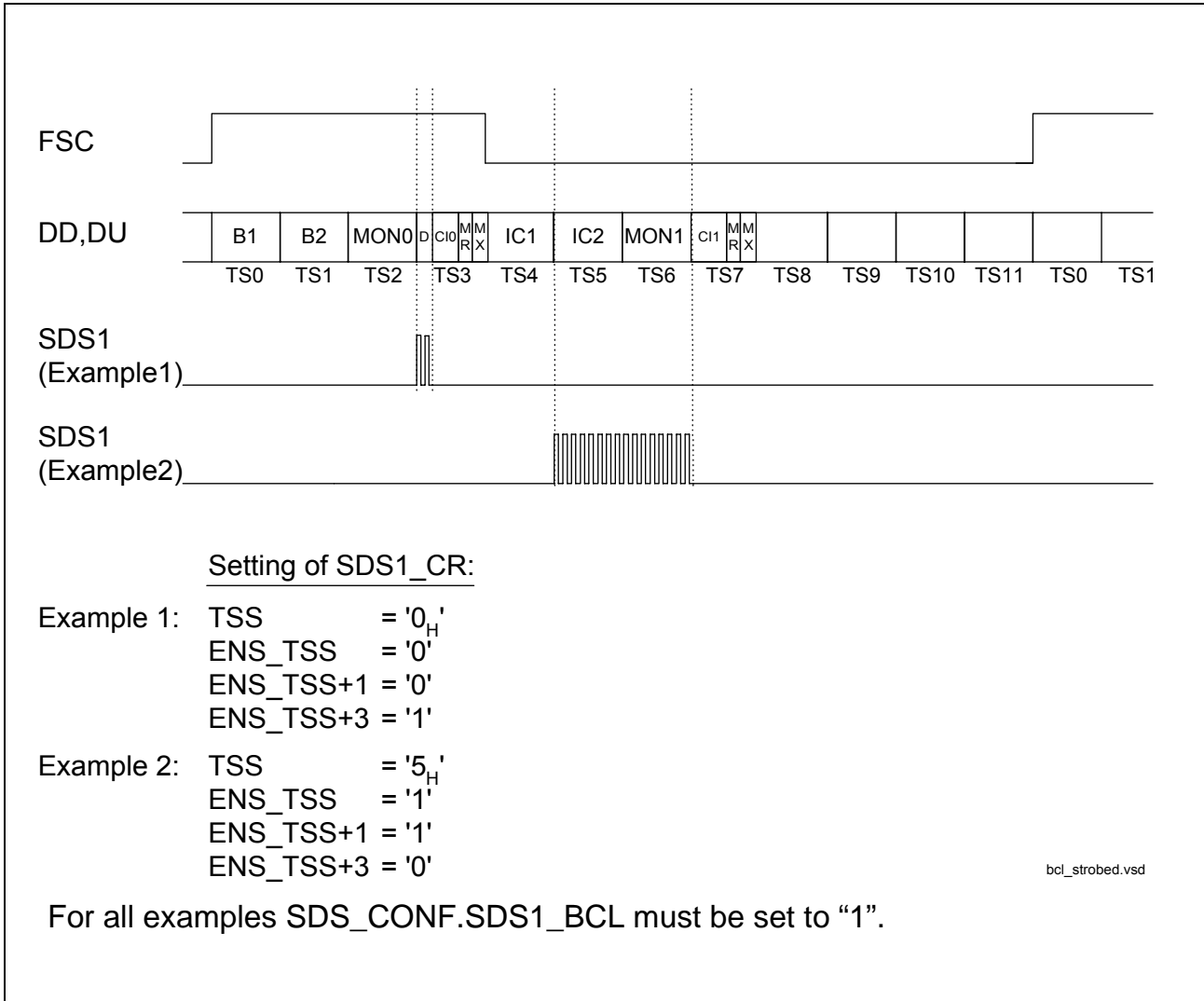

Figure 57 Strobed IOM-2 Bit Clock. Register SDS_CONF Programmed to 01_H

The strobed bit clock can be enabled in SDS_CONF.SDS1/2_BCL.

3.7.3 IOM-2 Monitor Channel

The IOM-2 MONITOR channel (see [Figure 58](#)) is utilized for information exchange in the MONITOR channel between a master mode device and a slave mode device.

The MONITOR channel data can be controlled by the bits in the MONITOR control register (MON_CR). For the transmission of the MONITOR data one of the IOM-2 channels (3 IOM-2 channels in TE mode, 8 channels in non TE mode) can be selected by setting the MONITOR channel selection bits (MCS) in the MONITOR control register (MON_CR).

The DPS bit in the same register selects between an output on DU or DD respectively and with EN_MON the MONITOR data can be enabled/disabled. The default value is MONITOR channel 0 (MON0) enabled and transmission on DD.

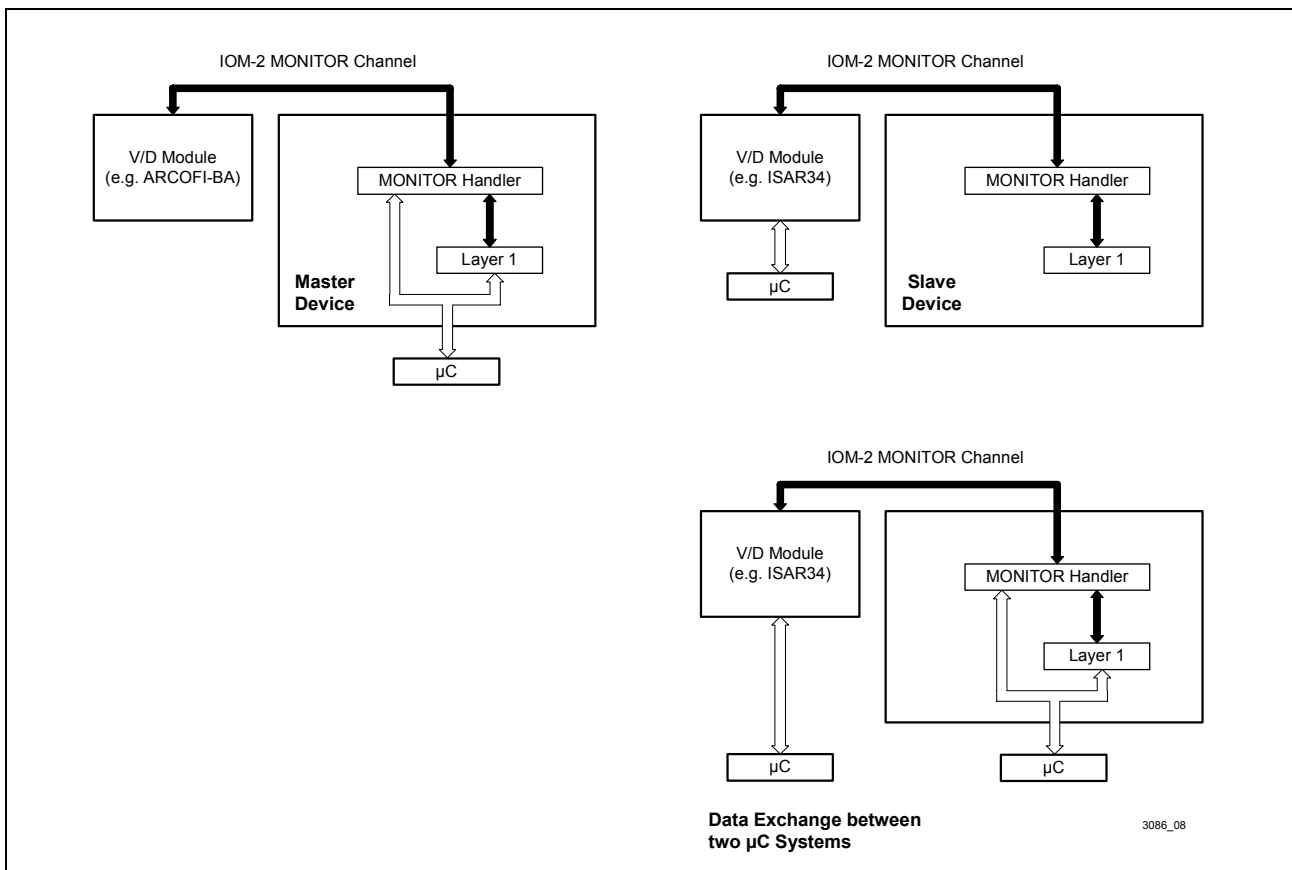

Figure 58 Examples of MONITOR Channel Applications in IOM -2 TE Mode

The MONITOR channel of the ISAC-SX can be used in following applications which are illustrated in [Figure 58](#):

- As a **master device** the ISAC-SX can program and control other devices attached to the IOM-2 which do not need a parallel microcontroller interface e.g. ARCOFI-BA PSB 2161. This facilitates redesigning existing terminal designs in which e.g. an interface of an expansion slot is realized with IOM-2 interface and monitor programming.

Description of Functional Blocks

- As a **slave device** the transceiver part of the ISAC-SX is programmed and controlled from a master device on IOM-2 (e.g. ISAR 34 PSB 7115). This is used in applications where no microcontroller is connected directly to the ISAC-SX in order to simplify host interface connection. The HDLC controlling is processed by the master device therefore the HDLC data is transferred via IOM-2 interface directly to the master device.
- For **data exchange** between two microcontroller systems attached to two different devices on one IOM-2 backplane. Use of the MONITOR channel avoids the necessity of a dedicated serial communication path between the two systems. This simplifies the system design of terminal equipment.

3.7.3.1 Handshake Procedure

The MONITOR channel operates on an asynchronous basis. While data transfers on the bus take place synchronized to frame sync, the flow of data is controlled by a handshake procedure using the MONITOR Channel Receive (MR) and MONITOR Channel Transmit (MX) bits. Data is placed onto the MONITOR channel and the MX bit is activated. This data will be transmitted once per 8-kHz frame until the transfer is acknowledged via the MR bit.

The MONITOR channel protocol is described in the following section and [Figure 59](#) illustrates this. The relevant control and status bits for transmission and reception are listed in [Table 12](#) and [Table 13](#).

Table 12 Transmit Direction

Control/ Status Bit	Register	Bit	Function
Control	MOCR	MXC	MX Bit Control
		MIE	Transmit Interrupt Enable
Status	MOSR	MDA	Data Acknowledged
		MAB	Data Abort
	MSTA	MAC	Transmission Active

Table 13 Receive Direction

Control/ Status Bit	Register	Bit	Function
Control	MOCR	MRC	MR Bit Control
		MRE	Receive Interrupt Enable
Status	MOSR	MDR	Data Received
		MER	End of Reception

Description of Functional Blocks

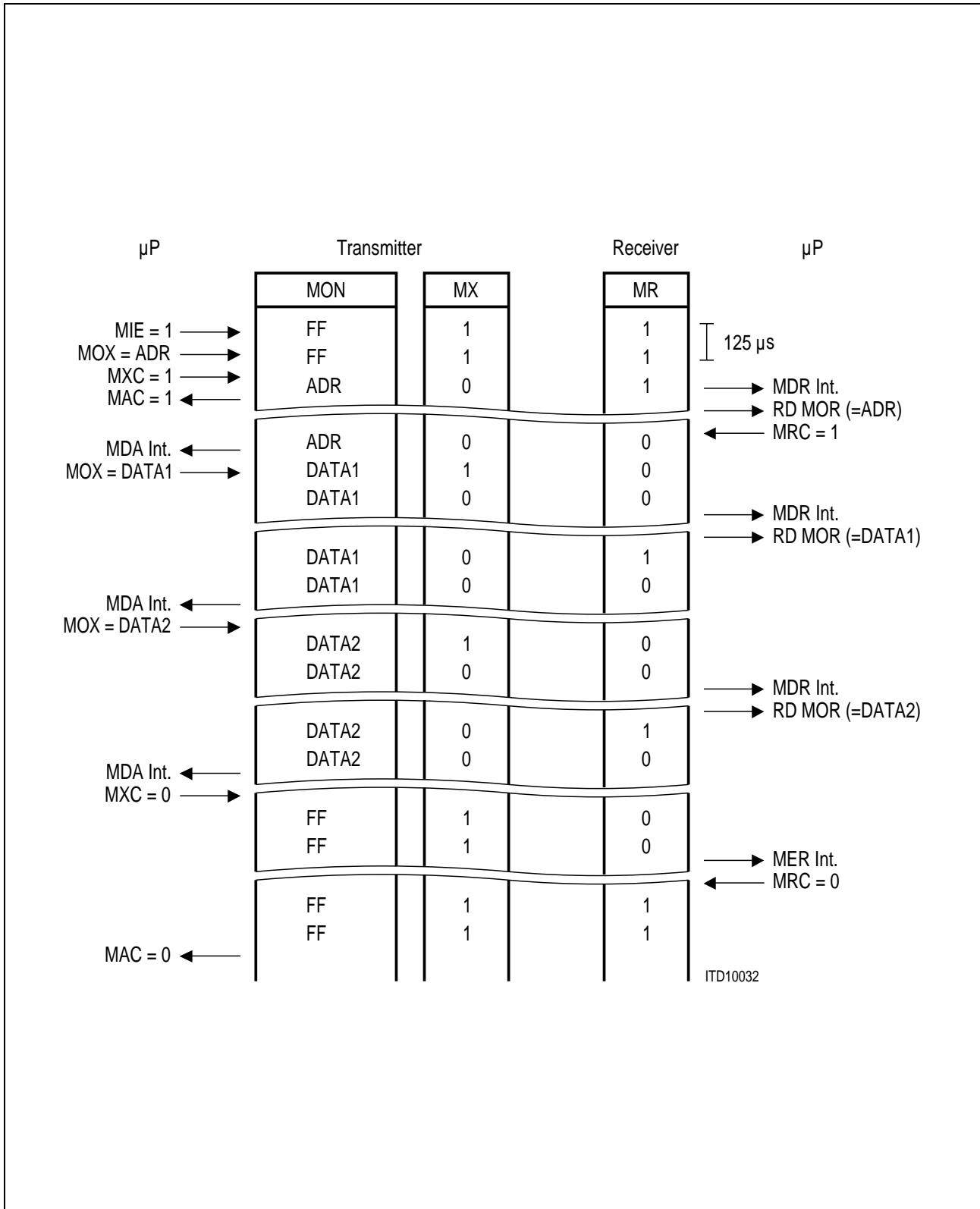

Figure 59 MONITOR Channel Protocol (IOM-2)

Description of Functional Blocks

Before starting a transmission, the microprocessor should verify that the transmitter is inactive, i.e. that a possible previous transmission has been terminated. This is indicated by a '0' in the MONITOR Channel Active MAC status bit.

After having written the MONITOR Data Transmit (MOX) register, the microprocessor sets the MONITOR Transmit Control bit MXC to '1'. This enables the MX bit to go active (0), indicating the presence of valid MONITOR data (contents of MOX) in the corresponding frame. As a result, the receiving device stores the MONITOR byte in its MONITOR Receive MOR register and generates an MDR interrupt status.

Alerted by the MDR interrupt, the microprocessor reads the MONITOR Receive (MOR) register. When it is ready to accept data (e.g. based on the value in MOR, which in a point-to-multipoint application might be the address of the destination device), it sets the MR control bit MRC to '1' to enable the receiver to store succeeding MONITOR channel bytes and acknowledge them according to the MONITOR channel protocol. In addition, it enables other MONITOR channel interrupts by setting MONITOR Interrupt Enable (MIE) to '1'.

As a result, the first MONITOR byte is acknowledged by the receiving device setting the MR bit to '0'. This causes a MONITOR Data Acknowledge MDA interrupt status at the transmitter.

A new MONITOR data byte can now be written by the microprocessor in MOX. The MX bit is still in the active (0) state. The transmitter indicates a new byte in the MONITOR channel by returning the MX bit active after sending it once in the inactive state. As a result, the receiver stores the MONITOR byte in MOR and generates a new MDR interrupt status. When the microprocessor has read the MOR register, the receiver acknowledges the data by returning the MR bit active after sending it once in the inactive state. This in turn causes the transmitter to generate an MDA interrupt status.

This "MDA interrupt – write data – MDR interrupt – read data – MDA interrupt" handshake is repeated as long as the transmitter has data to send. Note that the MONITOR channel protocol imposes no maximum reaction times to the microprocessor.

When the last byte has been acknowledged by the receiver (MDA interrupt status), the microprocessor sets the MONITOR Transmit Control bit MXC to '0'. This enforces an inactive ('1') state in the MX bit. Two frames of MX inactive signifies the end of a message. Thus, a MONITOR Channel End of Reception MER interrupt status is generated by the receiver when the MX bit is received in the inactive state in two consecutive frames. As a result, the microprocessor sets the MR control bit MRC to 0, which in turn enforces an inactive state in the MR bit. This marks the end of the transmission, making the MONITOR Channel Active MAC bit return to '0'.

During a transmission process, it is possible for the receiver to ask a transmission to be aborted by sending an inactive MR bit value in two consecutive frames. This is effected by the microprocessor writing the MR control bit MRC to '0'. An aborted transmission is indicated by a MONITOR Channel Data Abort MAB interrupt status at the transmitter.

The MONITOR transfer protocol rules are summarized in the following section:

Description of Functional Blocks

- A pair of MX and MR in the inactive state for two or more consecutive frames indicates an **idle state** or an **end of transmission**.
- A **start of a transmission** is initiated by the transmitter by setting the MXC bit to '1' enabling the internal MX control. The receiver acknowledges the received first byte by setting the MR control bit to '1' enabling the internal MR control.
- The internal MX,MR control indicates or acknowledges a new byte in the MON slot by toggling MX,MR from the active to the inactive state for one frame.
- Two frames with the MX-bit in the inactive state indicate the **end of transmission**.
- Two frames with the MR-bit set to inactive indicate a receiver request for **abort**.
- The transmitter can **delay a transmission** sequence by sending the same byte continuously. In that case the MX-bit remains active in the IOM-2 frame following the first byte occurrence. Delaying a transmission sequence is only possible while the receiver MR-bit and the transmitter MX-bit are active.
- Since a **double last-look criterion** is implemented the receiver is able to receive the MON slot data at least twice (in two consecutive frames), the receiver waits for the acknowledge of the reception of two identical bytes in two successive frames.
- To control this handshake procedure a collision detection mechanism is implemented in the transmitter. This is done by making a **collision check** per bit on the transmitted MONITOR data and the MX bit.
- Monitor data will be transmitted repeatedly until its reception is acknowledged or the transmission time-out timer expires.
- Two frames with the MX bit in the inactive state indicates the **end of a message** (EOM).
- Transmission and reception of monitor messages can be performed simultaneously. This feature is used by the ISAC-SX to send back the response before the transmission from the controller is completed (the ISAC-SX does not wait for EOM from controller).

3.7.3.2 Error Treatment

In case the ISAC-SX does not detect identical monitor messages in two successive frames, transmission is not aborted. Instead the ISAC-SX will wait until two identical bytes are received in succession.

A transmission is aborted of the ISAC-SX if

- an error in the MR handshaking occurs
- a collision on the IOM-2 bus of the MONITOR data or MX bit occurs
- the transmission time-out timer expires

A reception is aborted by the device if

- an error in the MX handshaking occurs or
- an abort request from the opposite device occurs

MX/MR Treatment in Error Case

In the master mode the MX/MR bits are under control of the microcontroller through MXC or MRC, respectively. An abort is indicated by an MAB interrupt or MER interrupt, respectively.

In the slave mode the MX/MR bits are under control of the device. An abort is always indicated by setting the MX/MR bit inactive for two or more IOM-2 frames. The controller must react with EOM.

Figure 60 shows an example for an abort requested by the receiver, **Figure 61** shows an example for an abort requested by the transmitter and **Figure 62** shows an example for a successful transmission.

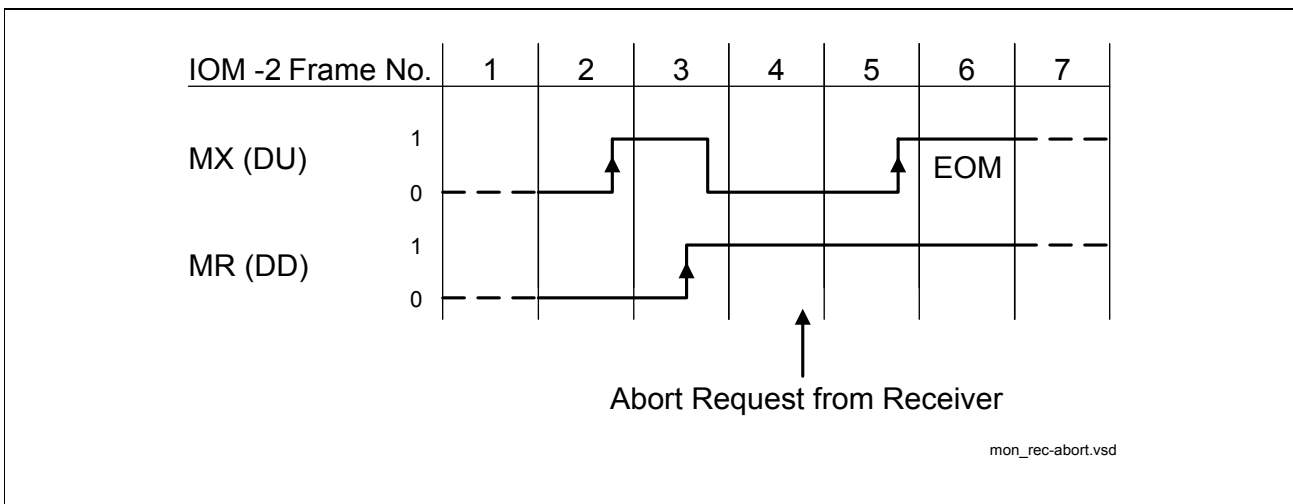

Figure 60 Monitor Channel, Transmission Abort requested by the Receiver

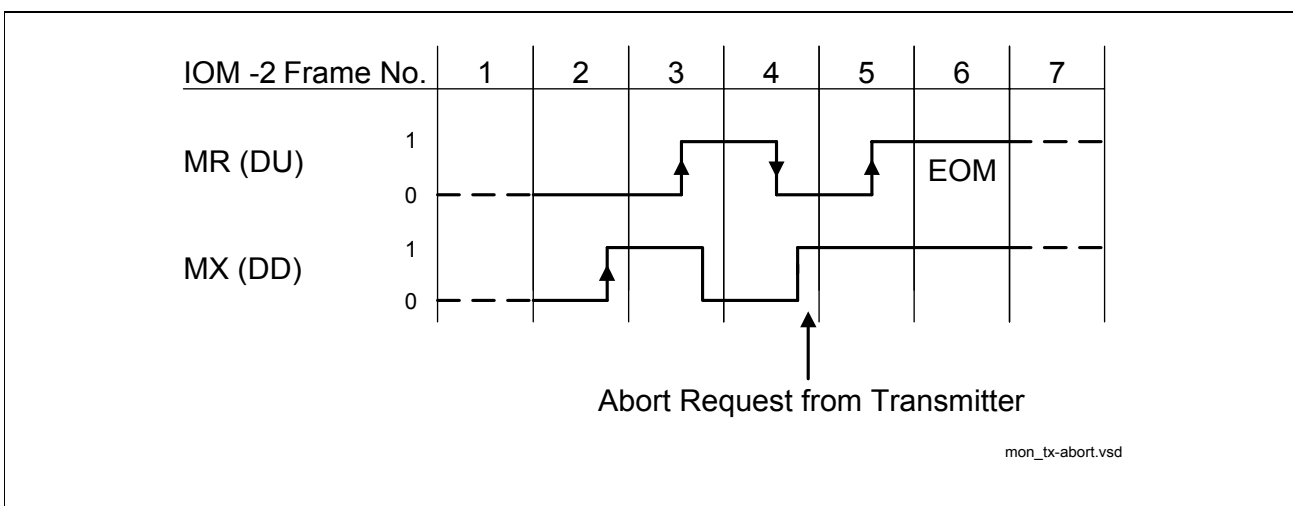

Figure 61 Monitor Channel, Transmission Abort requested by the Transmitter

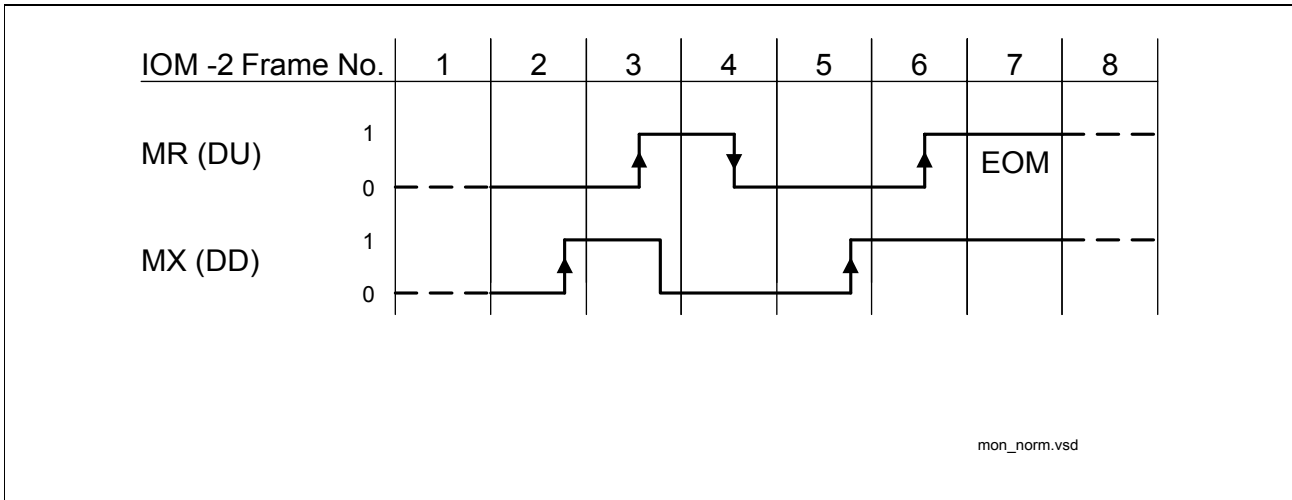

Figure 62 Monitor Channel, Normal End of Transmission

3.7.3.3 MONITOR Channel Programming as a Master Device

As a master device the ISAC-SX can program and control other devices attached to the IOM-2 interface. The master mode is selected by default if one of the possible microcontroller interfaces are selected. The monitor data is written by the microprocessor in the MOX register and transmitted via IOM-2 DD (DU) line to the programmed/controlled device e.g. ARCOFI-BA PSB 2161 or IEC-Q TE PSB 21911. The transfer of the commands in the MON channel is regulated by the handshake protocol mechanism with MX, MR which is described in the previous chapter [Chapter 3.7.3.1](#).

If the transmitted command was a read command the slave device responds by sending the requested data.

The data structure of the transmitted monitor message depends on the device which is programmed. Therefore the first byte of the message is a specific address code which contains in the higher nibble a MONITOR channel address to identify different devices. The length of the messages depends on the accessed device and the type of MONITOR command.

3.7.3.4 MONITOR Channel Programming as a Slave Device

In applications without direct host controller connection the ISAC-SX must operate in the MONITOR slave mode which can be selected by pinstrapping the microcontroller interface pins according **Table 3** respectively in **Chapter 3.2**. As a slave device the transceiver part of the ISAC-SX is programmed and controlled by a master device at the IOM-2 interface. All programming data required by the ISAC-SX is received in the MONITOR time slot on the IOM-2 and is transferred in the MOR register. The transfer of the commands in the MON channel is regulated by the handshake protocol mechanism with MX, MR which is described in the previous **Chapter 3.7.3.1**.

The first byte of the MONITOR message must contain in the higher nibble the MONITOR channel address code which is '1010' for the ISAC-SX. The lower nibble distinguishes between a programming command or an identification command.

Identification Command

In order to be able to identify unambiguously different hardware designs of the ISAC-SX by software, the following identification command is used:

DD 1st byte value	1	0	1	0	0	0	0	0
DD 2nd byte value	0	0	0	0	0	0	0	0

The ISAC-SX responds to this DD identification sequence by sending a DU identification sequence:

DU 1st byte value	1	0	1	0	0	0	0	0
DU 2nd byte value	0	1	DESIGN				<IDENT>	

DESIGN:six bit code, specific for each device in order to identify differences in operation
e.g. 000001: ISAC-SX PEB 3086 V 1.4

This identification sequence is usually done once, when the terminal is connected for the first time. This function is used so that the software can distinguish between different possible hardware configurations. However this sequence is not compulsory.

Programming Sequence

The programming sequence is characterized by a '1' being sent in the lower nibble of the received address code. The data structure after this first byte and the principle of a read/write access to a register is similar to the structure of the serial control interface described in [Chapter 3.2.1.1](#). For write access the header 43_H/47_H can be used and for read access the header 40_H/44_H.

DD 1st byte value	1	0	1	0	0	0	0	1
DD 2nd byte value	Header Byte							
DD 3rd byte value	R/W	Register Address						
DD 4th byte value	Data 1							
DD (nth + 3) byte value	Data n							

All registers can be read back when setting the R/W bit in the byte for the command/register address. The ISAC-SX responds by sending its IOM-2 specific address byte (A1_H) followed by the requested data.

Note: Application Hint:

It is not allowed to disable the MX- and MR-control in the programming device at the same time! First, the MX-control must be disabled, then the μ C has to wait for an End of Reception before the MR-control may be disabled. Otherwise, the ISAC-SX does not recognize an End of Reception.

3.7.3.5 Monitor Time-Out Procedure

To prevent lock-up situations in a MONITOR transmission a time-out procedure can be enabled by setting the time-out bit (TOUT) in the MONITOR configuration register (MCONF). An internal timer is always started when the transmitter must wait for the reply of the addressed device. After 5 ms without reply the timer expires and the transmission will be aborted with a EOM (End of Message) command by setting the MX bit to '1' for two consecutive IOM-2 frames.

3.7.3.6 MONITOR Interrupt Logic

Figure 63 shows the MONITOR interrupt structure of the ISAC-SX. The MONITOR Data Receive interrupt status **MDR** has two enable bits, MONITOR Receive interrupt Enable (**MRE**) and MR bit Control (**MRC**). The MONITOR channel End of Reception **MER**, MONITOR channel Data Acknowledged **MDA** and MONITOR channel Data Abort **MAB** interrupt status bits have a common enable bit MONITOR Interrupt Enable **MIE**.

MRE prevents the occurrence of **MDR** status, including when the first byte of a packet is received. When **MRE** is active (1) but **MRC** is inactive, the **MDR** interrupt status is generated only for the first byte of a receive packet. When both **MRE** and **MRC** are active, **MDR** is always generated and all received MONITOR bytes - marked by a 1-to-0 transition in MX bit - are stored. (Additionally, an active **MRC** enables the control of the MR handshake bit according to the MONITOR channel protocol.)

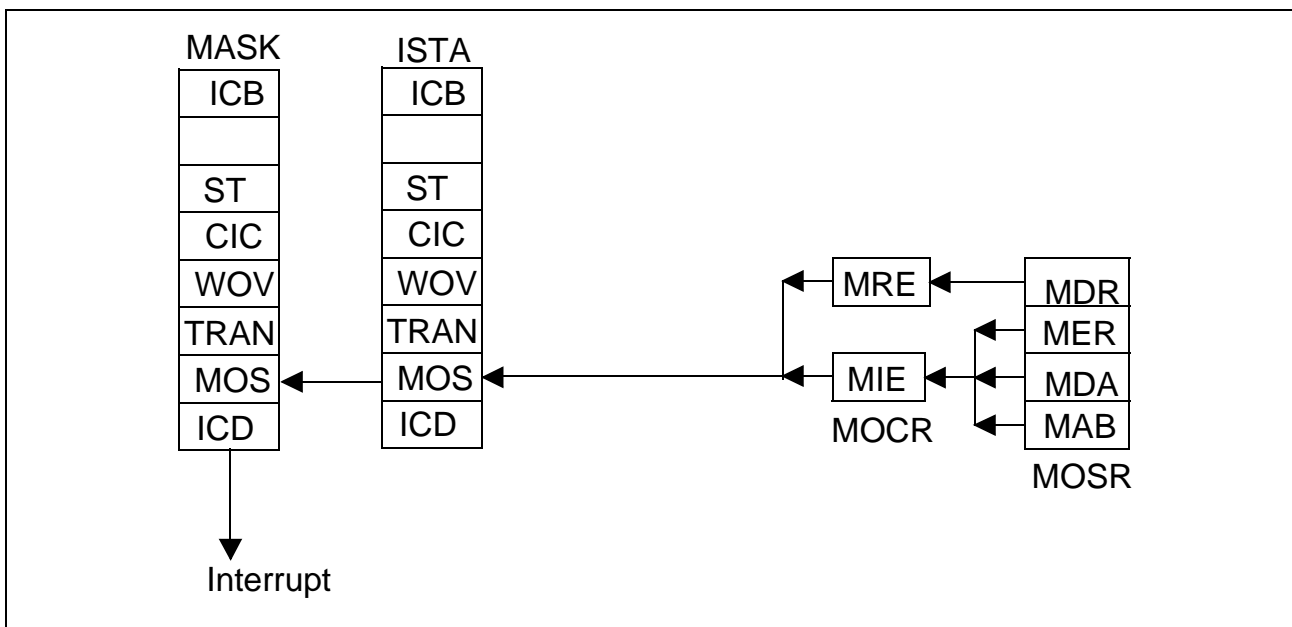

Figure 63 MONITOR Interrupt Structure

3.7.4 C/I Channel Handling

The Command/Indication channel carries real-time status information between the ISAC-SX and another device connected to the IOM-2 interface.

1. One C/I channel (called C/I0) conveys the commands and indications between the layer-1 and the layer-2 parts of the ISAC-SX. It can be accessed by an external layer-2 device e.g. to control the layer-1 activation/deactivation procedures. C/I0 channel access may be arbitrated via the TIC bus access protocol. In this case the arbitration is done in IOM-2 channel 2 (see **Figure 46**).

The C/I0 channel is accessed via register CIR0 (in receive direction, layer-1 to layer-2) and register CIX0 (in transmit direction, layer-2 to layer-1). The C/I0 code is four bits long. A listing and explanation of the layer-1 C/I codes can be found in **Chapter 3.5.4**.

Description of Functional Blocks

In the receive direction, the code from layer-1 is continuously monitored, with an interrupt being generated anytime a change occurs (ISTA.CIC). A new code must be found in two consecutive IOM-2 frames to be considered valid and to trigger a C/I code change interrupt status (double last look criterion).

In the transmit direction, the code written in CIX0 is continuously transmitted in C/I0.

2. A second C/I channel (called C/I1) can be used to convey real time status information between the ISAC-SX and various non-layer-1 peripheral devices e.g. PSB 2161 ARCOFI-BA. The C/I1 channel consists of four or six bits in each direction. The width can be changed from 4bit to 6bit by setting bit CIX1.CICW.

In 4-bit mode 6-bits are written whereby the higher 2 bits must be set to "1" and 6-bits are read whereby only the 4 LSBs are used for comparison and interrupt generation (i.e. the higher two bits are ignored).

The C/I1 channel is accessed via registers CIR1 and CIX1. A change in the received C/I1 code is indicated by an interrupt status without double last look criterion.

CIC Interrupt Logic

Figure 64 shows the CIC interrupt structure.

A CIC interrupt may originate

- from a change in received C/I channel 0 code (CIC0)

or

- from a change in received C/I channel 1 code (CIC 1).

The two corresponding status bits CIC0 and CIC1 are read in CIR0 register. CIC1 can be individually disabled by clearing the enable bit CI1E in the CIX1 register. In this case the occurrence of a code change in CIR1 will not be displayed by CIC1 until the corresponding enable bit has been set to one.

Bits CIC0 and CIC1 are cleared by a read of CIR0.

An interrupt status is indicated every time a valid new code is loaded in CIR0 or CIR1. The CIR0 is buffered with a FIFO size of two. If a second code change occurs in the received C/I channel 0 before the first one has been read, immediately after reading of CIR0 a new interrupt will be generated and the new code will be stored in CIR0. If several consecutive codes are detected, only the first and the last code is obtained at the first and second register read, respectively.

For CIR1 no FIFO is available. The actual code of the received C/I channel 1 is always stored in CIR1.

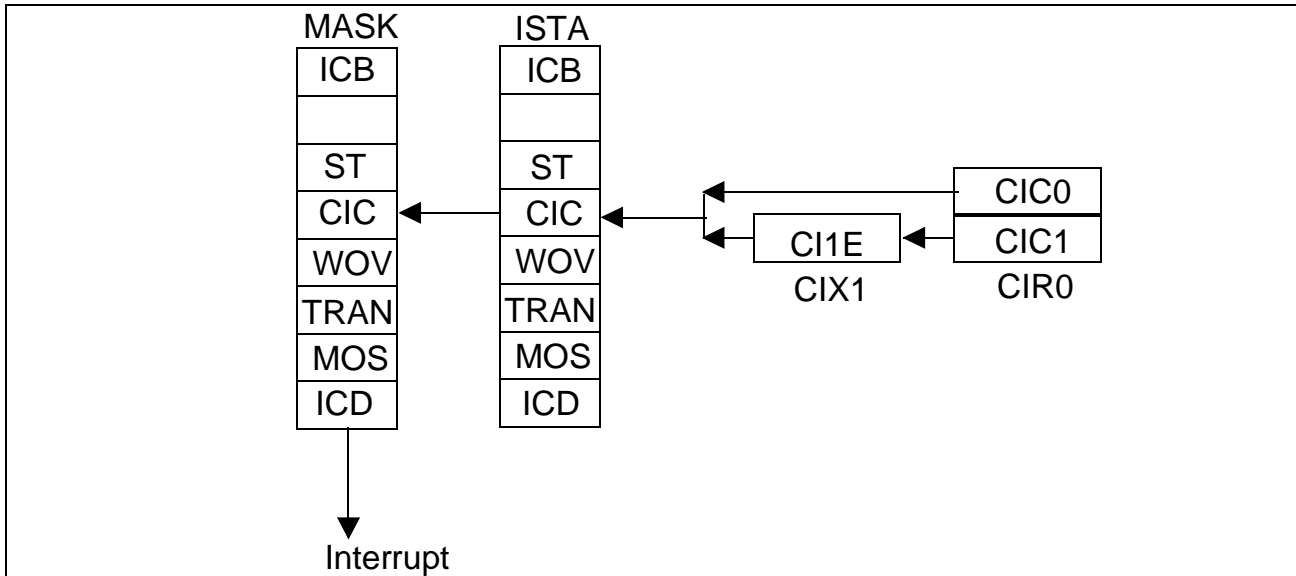

Figure 64 CIC Interrupt Structure

3.7.5 D-Channel Access Control

D-channel access control is defined to guarantee all connected TEs and HDLC controllers a fair chance to transmit data in the D-channel. Collisions are possible

- on the IOM-2 interface if there is more than one HDLC controller connected or
- on the S-interface when there is more than one terminal connected in a point to multipoint configuration (NT → TE1 ... TE8).

Both arbitration mechanisms are implemented in the ISAC-SX and will be described in the following two chapters.

3.7.5.1 TIC Bus D-Channel Access Control

The TIC bus is implemented to organize the access to the layer-1 functions provided in the ISAC-SX (C/I-channel) and to the D-channel from up to 7 external communication controllers (see [Figure 65](#)).

Note: The TIC Bus can be used in TE/iNT mode only. In other modes it has to be switched off in order not to disturb the layer-1 control and the HDLC controller. This is done by setting bit DIM 1 in register Mode D and bit 4 in register IOM_CR. For more details please refer to the application note "Reconfigurable PBX".

To this effect the outputs of the D-channel controllers (e.g. ICC - ISDN Communication Controller PEB 2070) are wired-or (negative logic, i.e. a "0" wins) and connected to pin DU. The inputs of the ICCs are connected to pin DD. External pull-up resistors on DU/DD are required. The arbitration mechanism must be activated by setting MODED.DIM2-0=00x.

Description of Functional Blocks

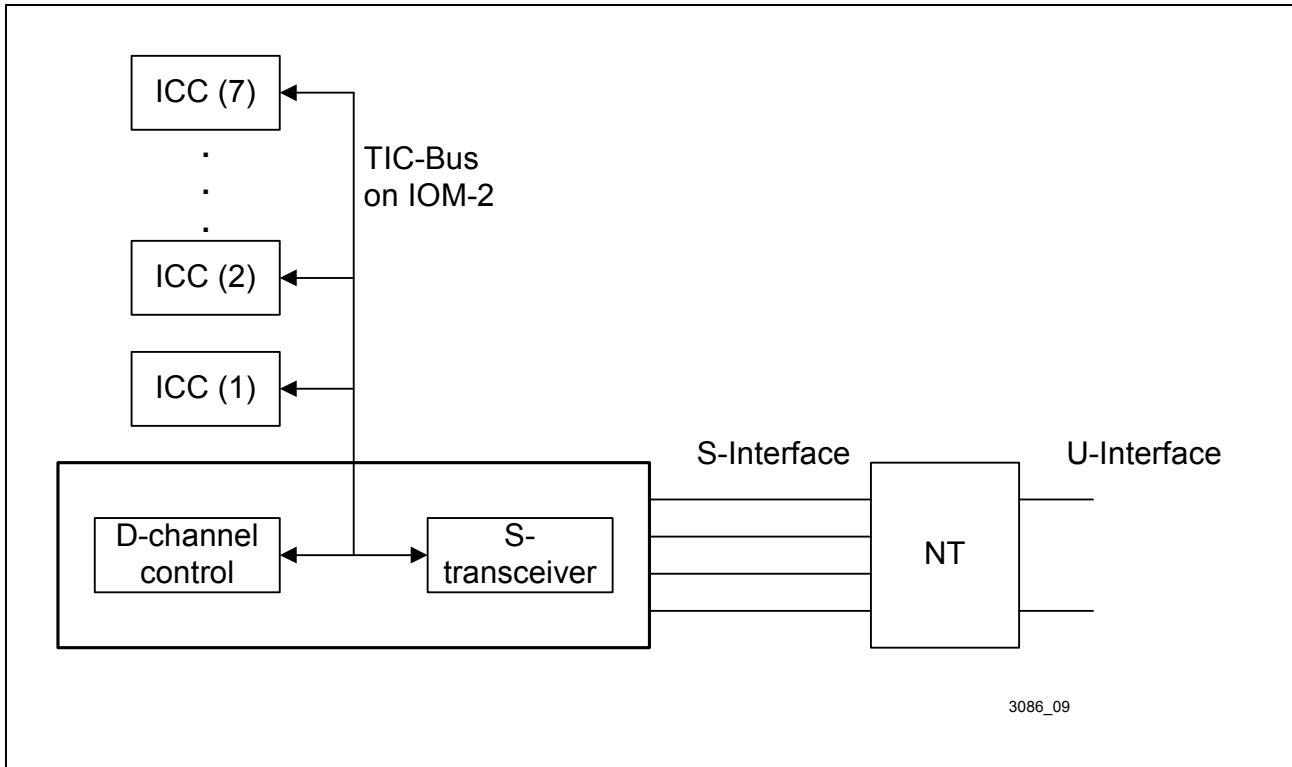

Figure 65 Applications of TIC Bus in IOM-2 Bus Configuration

The arbitration mechanism is implemented in the last octet in IOM-2 channel 2 of the IOM-2 interface (see [Figure 66](#)). An access request to the TIC bus may either be generated by software (μ P access to the C/I channel) or by the ISAC-SX itself (transmission of an HDLC frame in the D-channel). A software access request to the bus is effected by setting the BAC bit (CIX0 register) to '1'.

In the case of an access request, the ISAC-SX checks the Bus Accessed-bit BAC (bit 5 of last octet of CH2 on DU, see [Figure 66](#)) for the status "bus free", which is indicated by a logical '1'. If the bus is free, the ISAC-SX transmits its individual TIC bus address TAD programmed in the CIX0 register (CIX0.TBA2-0). The ISAC-SX sends its TIC bus address TAD and compares it bit by bit with the value on DU. If a sent bit set to '1' is read back as '0' because of the access of another D-channel source with a lower TAD, the ISAC-SX withdraws immediately from the TIC bus, i.e. the remaining TAD bits are not transmitted. The TIC bus is occupied by the device which sends its address error-free. If more than one device attempt to seize the bus simultaneously, the one with the lowest address values wins. This one will set BAC=0 on TIC bus and starts D-channel transmission in the same frame.

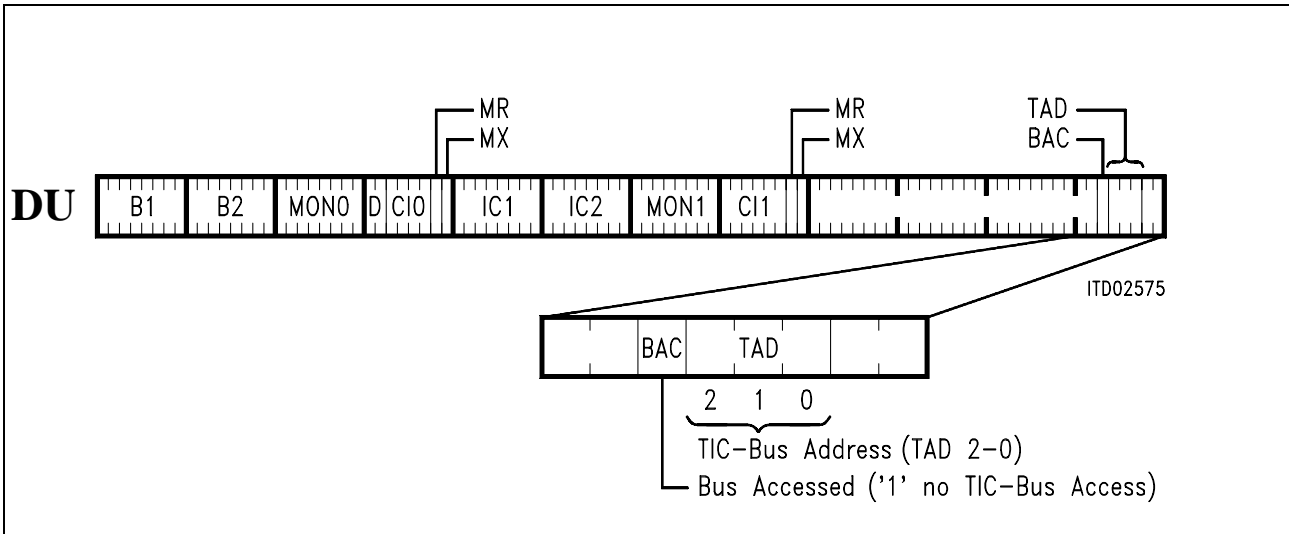

Figure 66 Structure of Last Octet of Ch2 on DU

When the TIC bus is seized by the ISAC-SX, the bus is identified to other devices as occupied via the DU Ch2 Bus Accessed-bit state '0' until the access request is withdrawn. After a successful bus access, the ISAC-SX is automatically set into a lower priority class, that is, a new bus access cannot be performed until the status "bus free" is indicated in two successive frames.

If none of the devices connected to the IOM-2 interface request access to the D and C/I channels, the TIC bus address 7 will be present. The device with this address will therefore have access, by default, to the D and C/I channels.

Note: Bit BAC (CIX0 register) should be reset by the μP when access to the C/I channels is no more requested, to grant other devices access to the D and C/I channels.

3.7.5.2 S-Bus Priority Mechanism for D-Channel

The S-bus access procedure specified in ITU I.430 was defined to organize D-channel access with multiple TEs connected to a single S-bus (see [Figure 68](#)).

To implement collision detection the D (channel) and E (echo) bits are used. The D-channel S-bus condition is indicated towards the IOM-2 interface with the S/G bit, i.e. the availability of the S/T interface D channel is indicated in bit 5 "Stop/Go" (S/G) of the DD last octet of Ch2 channel ([Figure 67](#)).

S/G = 1 : stop

S/G = 0 : go

Description of Functional Blocks

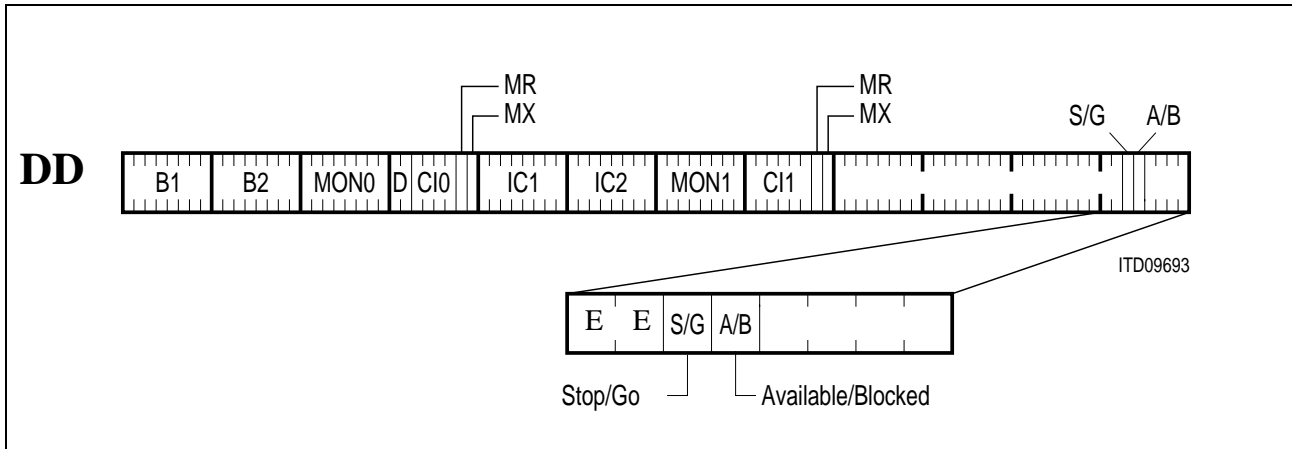

Figure 67 Structure of Last Octet of Ch2 on DD

The Stop/Go bit is available to other layer-2 devices connected to the IOM-2 interface to determine if they can access the S/T bus D channel.

The access to the D-channel is controlled by a priority mechanism which ensures that all competing TEs are given a fair access chance. This priority mechanism discriminates among the kind of information exchanged and information exchange history: Layer-2 frames are transmitted in such a way that signalling information is given priority (priority class 1) over all other types of information exchange (priority class 2). Furthermore, once a TE having successfully completed the transmission of a frame, it is assigned a lower level of priority of that class. The TE is given back its normal level within a priority class when all TEs have had an opportunity to transmit information at the normal level of that priority class.

The priority mechanism is based on a rather simple method: A TE not transmitting layer-2 frames sends binary 1s on the D-channel. As layer-2 frames are delimited by flags consisting of the binary pattern “01111110” and zero bit insertion is used to prevent flag imitation, the D-channel may be considered idle if more than seven consecutive 1s are detected on the D-channel. Hence by monitoring the D echo channel, the TE may determine if the D-channel is currently used by another TE or not.

A TE may start transmission of a layer-2 frame first when a certain number of consecutive 1s has been received on the echo channel. This number is fixed to 8 in priority class 1 and to 10 in priority class 2 for the normal level of priority; for the lower level of priority the number is increased by 1 in each priority class, i.e. 9 for class 1 and 11 for class 2.

A TE, when in the active condition, is monitoring the D echo channel, counting the number of consecutive binary 1s. If a 0 bit is detected, the TE restarts counting the number of consecutive binary 1s. If the required number of 1s according to the actual level of priority has been detected, the TE may start transmission of an HDLC frame. If a collision occurs, the TE immediately shall cease transmission, return to the D-channel monitoring state, and send 1s over the D-channel.

Description of Functional Blocks

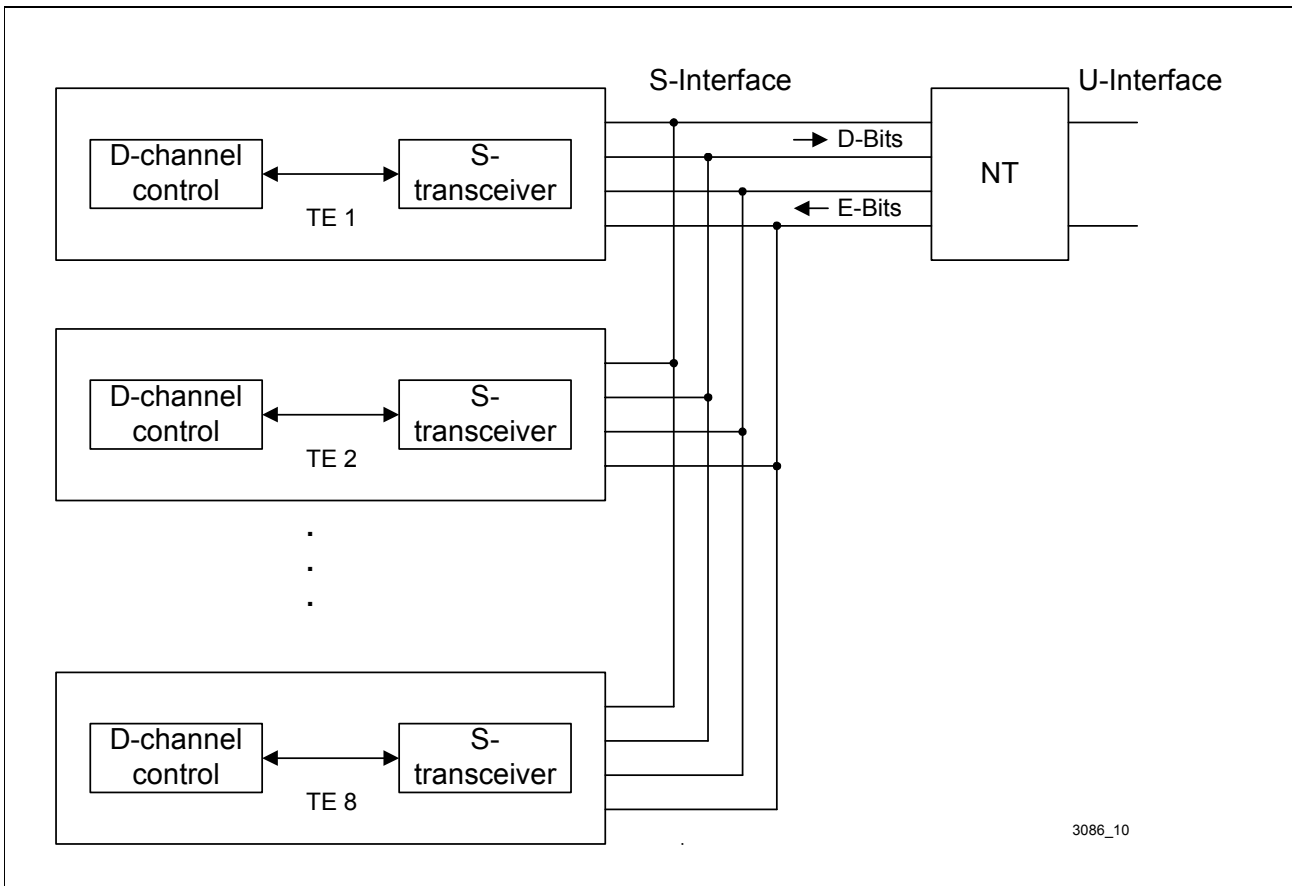

Figure 68 D-Channel Access Control on the S-Interface

S-Bus D-channel Access Control in the ISAC-SX

The above described priority mechanism is fully implemented in the ISAC-SX. For this purpose the D-channel collision detection according to ITU I.430 must be enabled by setting MODED.DIM2-0 to '0x1'. In this case the transceiver continuously compares the received E-echo bits with its own transmitted D data bits.

Depending on the priority class selected, 8 or 10 consecutive ONEs (high priority level, priority 8) need to be detected before the transceiver sends valid D-channel data on the upstream D-bits on S. In low priority level (priority 10) 10 or 11 consecutive ONEs are required.

The priority class (priority 8 or priority 10) is selected by transferring the appropriate activation command via the Command/Indication (C/I) channel of the IOM-2 interface to the transceiver. If the activation is initiated by a TE, the priority class is selected implicitly by the choice of the activation command. If the S-interface is activated from the NT, an activation command selecting the desired priority class should be programmed at the TE on reception of the activation indication (AI8 or AI10). In the activated state the priority class may be changed whenever required by simply programming the desired activation request command (AR8 or AR10).

3.7.5.3 S-Bus D-Channel Control in LT-T

If the TE frame structure on the IOM-2 interface is selected, the same D-channel access procedures as described in [Chapter 3.7.5.2](#) are used in LT-T mode.

For other frame structures used in LT-T mode, D-channel access on S is handled similarly, with the difference that the S/G bit is not available on IOM-2 but only on the S/G bit output pin (SGO).

3.7.5.4 D-Channel Control in the Intelligent NT (TIC- and S-Bus)

In intelligent NT applications (selected via register TR_MODE.MODE2-0) the ISAC-SX has to share the upstream D-channel with one or more D-channel controllers on the IOM-2 interface and with all connected TEs on the S interface.

The transceiver incorporates an elaborate statemachine for D-channel priority handling on IOM-2. For the access to the D-channel a similar arbitration mechanism as on the S interface (writing D-bits, reading back E-bits) is performed for all D-channel sources on IOM-2. Due to this an equal and fair access is guaranteed for all D-channel sources on both the S interface and the IOM-2 interface.

This arbitration mechanism is only available in IOM-2 TE mode (12 PCM timeslots) per frame with enabled TIC bus. The access to the upstream D-channel is handled via the S/G bit for the HDLC controllers and via E-bit for all connected terminals on S (E-bits are inverted to block the terminals on S). Furthermore, if more than one HDLC source is requesting D-channel access on IOM-2 the TIC bus mechanism is used.

The arbiter permanently counts the "1s" in the upstream D-channel on IOM-2. If the necessary number of "1s" is counted and an HDLC controller on IOM-2 requests upstream D-channel access (BAC bit is set to 0), the arbiter allows this D-channel controller immediate access and blocks other TEs on S (E-bits are inverted). Similar as on the S-interface the priority for D-channel access on IOM-2 can be configured to 8 or 10 (TR_CMD.DPRIO).

The upstream device can stop all D-channel sources by setting the A/B-bit to 0. The S/G bit is not evaluated in this mode.

The configuration settings of the ISAC-SX in intelligent NT applications are summarized in [Table 14](#).

Description of Functional Blocks

Table 14 ISAC-SX Configuration Settings in Intelligent NT Applications

Functional Block	Configuration Description	Configuration Setting
Layer 1	Select Intelligent NT mode	Transceiver Mode Register: TR_MODE.MODE0 = 0 (NT state machine) or TR_MODE.MODE0 = 1 (LT-S state machine) TR_MODE.MODE1 = 1 TR_MODE.MODE2 = 1
Layer 2	Enable S/G bit evaluation	D-channel Mode Register: MODED.DIM2-0 = 001

Note: For mode selection in the TR_MODE register the MODE2/1 bits are used to select intelligent NT mode, MODE0 selects NT or LT-S state machine.

With the configuration settings shown above the ISAC-SX in intelligent NT applications provides for equal access to the D-channel for terminals connected to the S-interface and for D-channel sources on IOM-2.

For a detailed understanding the following sections provide a complete description on the procedures used by the D-channel priority handler on IOM-2, although it may not be necessary to study that in order to use this mode.

Description of Functional Blocks

1. NT D-Channel Controller Transmits Upstream

In the initial state ('Ready' state) neither the local D-channel sources nor any of the terminals connected to the S-bus transmit in the D-channel.

The ISAC-SX S-transceiver thus receives BAC = "1" (IOM-2 DU line) and transmits S/G = "1" (IOM-2 DD line). The access will then be established according to the following procedure:

- Local D-channel source verifies that BAC bit is set to ONE (currently no bus access).
- Local D-channel source issues TIC bus address and verifies that no controller with higher priority requests transmission (TIC bus access must always be performed even if no other D-channel sources are connected to IOM-2).
- Local D-channel source issues BAC = "0" to block other sources on IOM-2 and to announce D-channel access.
- ISAC-SX S-transceiver pulls S/G bit to ZERO ('Idle' state) as soon as n D-bits = '1' are counted on IOM-2 (see note) to allow for further D-channel access.
- ISAC-SX S-transceiver transmits inverted echo channel (E bits) on the S-bus to block all connected S-bus terminals ($E = \overline{D}$).
- Local D-channel source commences with D data transmission on IOM-2 as long as it receives S/G = "0".
- After D-channel data transmission is completed the controller sets the BAC bit to ONE.
- ISAC-SX S-transceiver transmits non-inverted echo ($E = D$).
- ISAC-SX S-transceiver pulls S/G bit to ONE ('Ready' state) to block the D-channel controller on IOM-2.

Note: Right after transmission the S/G bit is pulled to '1' until n successive D-bits = '1' occur on the IOM-2 interface. As soon as n D-bits = '1' are seen, the S/G bit is set to '0' and the ISAC-SX D-channel controller may start transmission again (if TIC bus is occupied). This allows an equal access for D-channel sources on IOM-2 and on the S interface.

The number n depends on configuration settings (selected priority 8 or 10) and the condition of the previous transmission, i.e. if an abort was seen ($n = 8$ or 10, respectively) or if the last transmission was successful ($n = 9$ or 11, respectively).

Figure 69 illustrates the signal flow in an intelligent NT and the algorithm of the D-channel priority handler on IOM-2 implemented in the ISAC-SX.

Description of Functional Blocks

2. Terminal Transmits D-Channel Data Upstream

The initial state is identical to that described in the last paragraph. When one of the connected S-bus terminals needs to transmit in the D-channel, access is established according to the following procedure:

- ISAC-SX S-transceiver (in intelligent NT) recognizes that the D-channel on the S-bus is active.
- ISAC-SX S-transceiver transfers S-bus D-channel data transparently through to the upstream IOM-2 bus (IOM-2 channel 0).

For both cases described above the exchange indicates via the A/B bit (controlled by layer 1) that D-channel transmission on this line is permitted (A/B = "1"). Data transmission could temporarily be prohibited by the exchange when only a single D-channel controller handles more lines (A/B = "0", ELIC-concept).

In case the exchange prohibits D data transmission on this line the A/B bit is set to "0" (block). For U_{PN} applications with S extension this forces the intelligent NT ISAC-SX S-transceiver to transmit an inverted echo channel on the S-bus, thus disabling all terminal requests, and switches S/G to $\overline{A/B}$, which blocks the D-channel controller in the intelligent NT.

Note: Although the ISAC-SX S-transceiver operates in LT-S mode and is pinstrapped to IOM-2 channel 0 or 1 it will write into IOM-2 channel 2 at the S/G bit position.

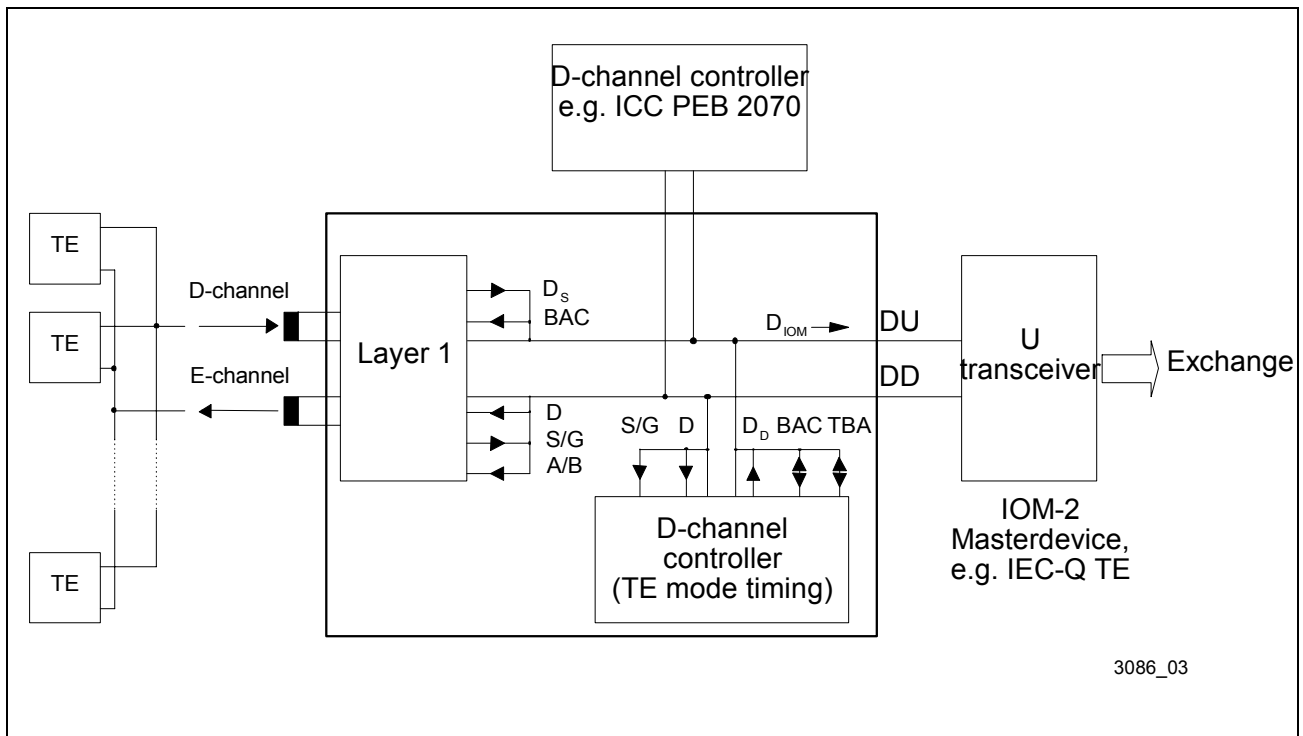

Figure 69 Data Flow for Collision Resolution Procedure in Intelligent NT

3.7.6 Activation/Deactivation of IOM-2 Interface

The IOM-2 interface can be switched off in the inactive state, reducing power consumption to a minimum. In this deactivated state is FSC = '1', DCL and BCL = '0' and the data lines are '1'.

The IOM-2 interface can be kept active while the S interface is deactivated by setting the CFS bit to "0" (MODE1 register). This is the case after a hardware reset. If the IOM-2 interface should be switched off while the S interface is deactivated, the CFS bit should be set to '1'. In this case the internal oscillator is disabled when no signal (info 0) is present on the S bus and the C/I command is '1111' = DIU. If the TE wants to activate the line, it has first to activate the IOM-2 interface either by using the "Software Power Up" function (IOM_CR.SPU bit) or by setting the CFS bit to "0" again.

The deactivation procedure is shown in **Figure 70**. After detecting the code DIU (Deactivate Indication Upstream) the layer 1 of the ISAC-SX responds by transmitting DID (Deactivate Indication Downstream) during subsequent frames and stops the timing signals synchronously with the end of the last C/I (C/I0) channel bit of the fourth frame.

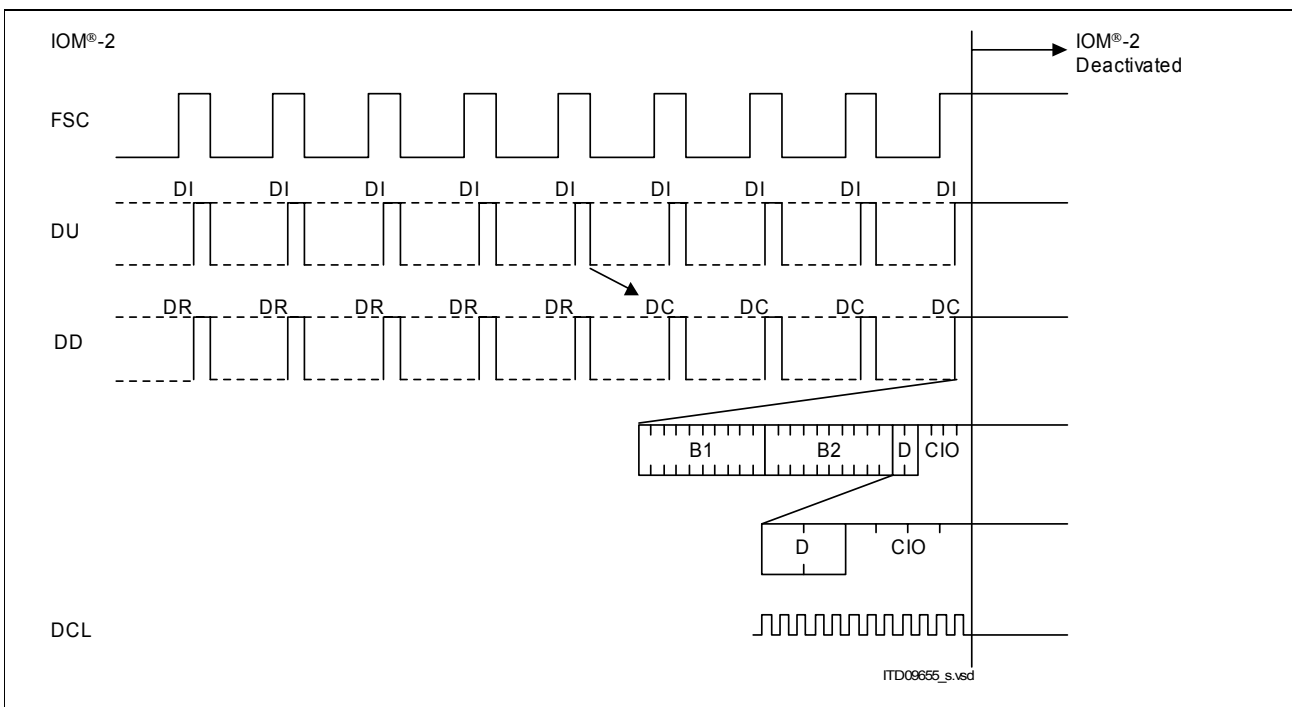

Figure 70 Deactivation of the IOM-2 Interface

The clock pulses will be enabled again when the DU line is pulled low (bit SPU in the IOM_CR register), i.e. the C/I command TIM = "0000" is received by layer 1, or when a non-zero level on the S-line interface is detected (if TR_CONF0.LDD=0). The clocks are turned on after approximately 0.2 to 4 ms depending on the oscillator.

DCL is activated such that its first rising edge occurs with the beginning of the bit following the C/I (C/I0) channel.

Description of Functional Blocks

After the clocks have been enabled this is indicated by the PU code in the C/I channel and, consequently, by a CIC interrupt. The DU line may be released by resetting the Software Power Up bit IOM_CR = '0' and the C/I code written to CIX0 before (e.g. TIM or AR8) is output on DU.

The ISAC-SX supplies IOM-2 timing signals as long as there is no DIU command in the C/I (C/I0) channel. If timing signals are no longer required and activation is not yet requested, this is indicated by programming DIU in the CIX0 register.

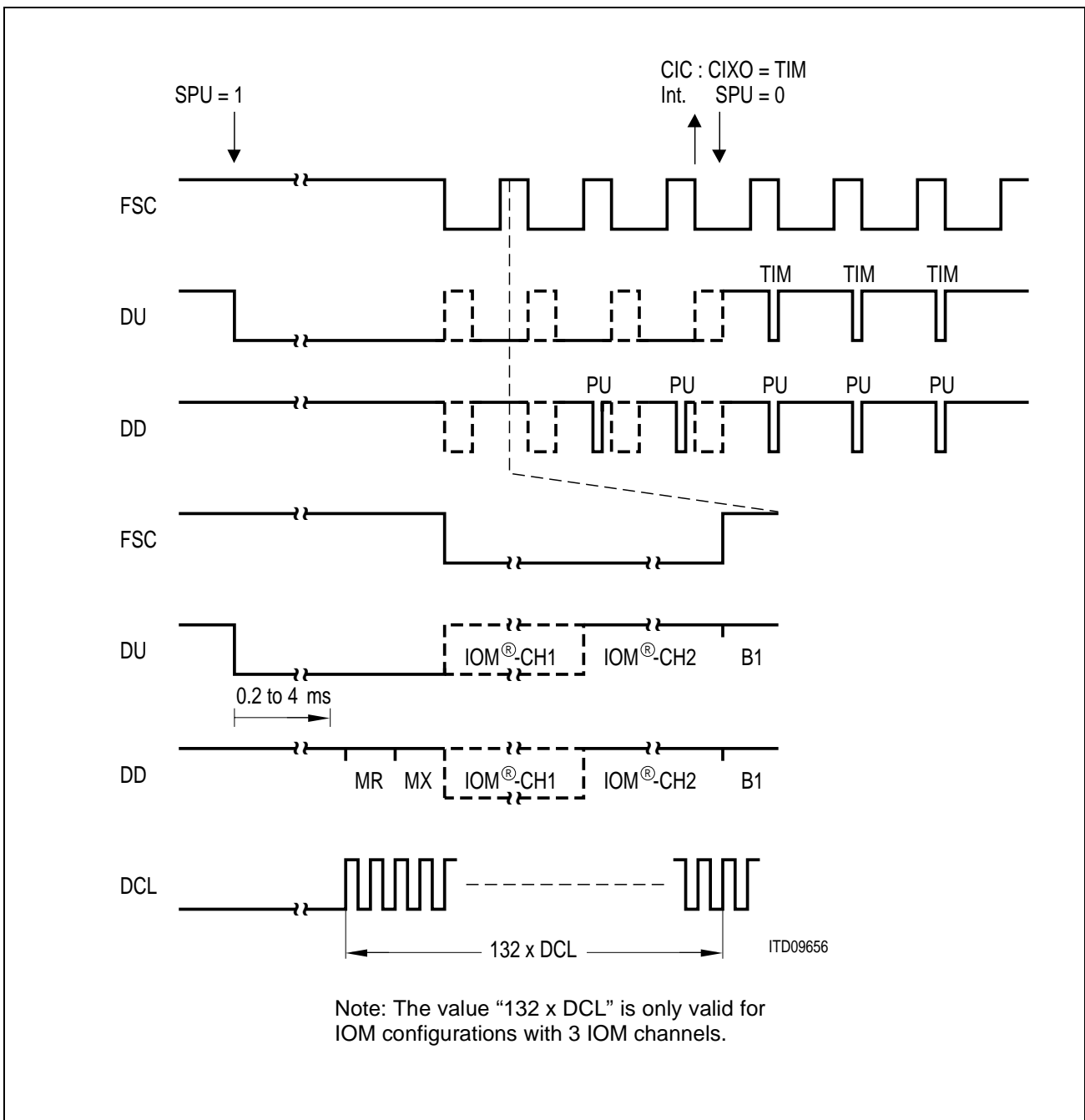

Figure 71 Activation of the IOM-2 interface

Description of Functional Blocks

Asynchronous Awake (LT-S, NT, Int. NT mode)

The transceiver is in power down mode (deactivated state) and MODE1.CFS=1 (TR_CONF0.LDD is don't care in this case). Due to any signal on the line the level detect circuit will asynchronously pull the DU line on IOM-2 to "0" which is deactivated again after 2 ms if the oscillator is fully operational. If the oscillator is just starting up in operational mode, the 2 ms duration is extended correspondingly.

3.8 Auxiliary Interface

3.8.1 Mode Dependent Functions

The AUX interface provides various functions, which depend on the operation mode (TE, LT-T, LT-S, NT or Intelligent NT mode) selected by pins MODE0 and MODE1/ $\overline{\text{EAW}}$ (see [Table 15](#)). After reset the pins are switched as inputs until further configuration is done by the host.

Table 15 AUX Pin Functions

Pin	TE, Int. NT mode	LT-T, LT-S, NT mode
AUX0	AUX0 (i/o)	CH0 (i)
AUX1	AUX1 (i/o)	CH1 (i)
AUX2	AUX2 (i/o)	CH2 (i)
AUX3	AUX3 (i/o)	AUX3 (i/o)
AUX4	AUX4 (i/o) / MBIT	AUX4 (i/o) / MBIT
AUX5	AUX5 (i/o) / FBOUT (o)	AUX5 (i/o) / FBOUT (o)
AUX6	INT0 (i/o)	INT0 (i/o)
AUX7	INT1 (i/o) / SGO (o)	INT1 (i/o) / SGO (o)

AUX0-5 (TE, Int. NT mode), AUX3-5 (LT-T, LT-S, NT mode)

These pins can be used as programmable I/O lines.

As inputs (AOE.OEx=1) the state at the pin is latched in when the host performs read operation to register ARX.

As outputs (AOE.OEx=0) the value in register ATX is driven on the pins with a minimum delay after the write operation to this register is performed. They can be configured as open drain (ACFG1.ODx=0) or push/pull outputs (ACFG1.ODx=1). The status ('1' or '0') at output pins can be read back from register ARX, which may be different from the ATX value, e.g. if another device drives a different level.

FBOUT

AUX5 is multiplexed with the selectable FSC/BCL output FBOUT, i.e. the host can select either standard I/O characteristic (ACFG2.A5SEL=0, default) or FBOUT functionality (ACFG2.A5SEL=1). FBOUT provides either an FSC (ACFG2.FBS=0, default) or BCL signal (ACFG2.FBS=1) which are derived from the DCL clock (also see [Chapter 3.4](#)).

Description of Functional Blocks

INT0, INT1

In all modes two pins can be used as programmable I/O with optional interrupt input capability (default after reset, i.e. both interrupts masked).

The $\overline{\text{INT0/1}}$ pins are general input or output pins like AUX0-5 (see description above). In addition to that, as inputs they can generate an interrupt to the host (AUXI.INT0/1) which is maskable in AUXM.INT0/1. The interrupt input is either edge or level triggered (ACFG2.EL0/1).

As outputs both pins can directly be connected to an LED with preresistor.

For both pins AUX6/7 internal pull-up resistors are provided if the pin is configured as input or as output with open drain characteristic. The internal pull-ups are disabled if output mode with push/pull characteristic is selected.

SGO

AUX7 provides the additional capability to output the S/G bit from the IOM-2 interface by setting ACFG2.A7SEL=1.

MBIT

If ACFG2.A4SEL is set to “1” the pin AUX4 is used for Multiframe Synchronizstion (see [Chapter 3.3.3](#)) and all configuration as general purpose I/O pin is don’t care. In TE and LT-T modes it is used as M-Bit output and in LT-S, NT and Int. NT mode it is used as M-Bit input.

CH0, CH1, CH2

In linecard mode one FSC frame is a multiplex of up to eight IOM-2 channels, each of them consisting of B1-, B2-, MONITOR-, D- and C/I-channel and MR- and MX-bits. So in LT-T and LT-S mode one of eight channels on the IOM-2 interface is selected by CH0-2. These pins must be strapped to VDD or VSS according to [Table 16](#).

Table 16 IOM-2 Channel Selection

CH2	CH1	CH0	Channel on IOM-2
0	0	0	0
0	0	1	1
0	1	0	2
0	1	1	3
1	0	0	4
1	0	1	5
1	1	0	6
1	1	1	7

Description of Functional Blocks

For DCL = 1.536 MHz one of the IOM-2 channels 0 - 2 can be selected, for DCL = 4.096 MHz any of the eight IOM-2 channels can be selected.

The channel select pins have direct effect on the timeslot selection of the following registers:

- TR_TSDP_BC1
- TR_TSDP_BC2
- TR_CR, TRC_CR
- DCI_CR, DCIC_CR
- MON_CR

HDLC Controllers

The ISAC-SX contains two HDLC controllers. The first one is used for the layer-2 functions of the D- channel protocol (LAPD), the second one provides B-channel access with reduced FIFO thresholds which can be used for firmware upgrade via the line for example. By setting the Enable HDLC channel bits (EN_D, EN_B1H) in the DCI_CR/ BCH_CR registers each of the HDLC controllers can access the D or B-channels on IOM-2.

They perform the framing functions used in HDLC based communication: flag generation/recognition, bit stuffing, CRC check and address recognition.

The FIFO has a size of 64 byte per direction for the D-channel and 128 byte per direction for the B-channel. They are implemented as cyclic buffers. The transceiver reads and writes data sequentially with constant data rate whereas the data transfer between FIFO and microcontroller uses a block oriented protocol with variable block sizes.

The configuration, control and status bits related to the HDLC controllers are all assigned to the following address ranges:

Table 17 HDLC Controller Address Range

	FIFO Address	Config/Ctrl/Status Registers
D-channel	00 _H -1F _H	20 _H -29 _H
B-channel	7A _H	70 _H -79 _H

Note: For B-channel data access a single address location is used to read from and write to the FIFO. For D-channel access the address range 00_H-1F_H is used (similar as in ISAC-S PEB 2086), however a single address from this range is sufficient to access the FIFO as the internal FIFO pointer is incremented automatically independent from the external address.

The mechanisms for access to the FIFOs are identical for D- and B-channels, therefore the following description applies to both of them and for simplification specific references

Description of Functional Blocks

like registers are indicated by an “x” (stands for “D” and “B”) to indicate it is relevant for D- and B-channel (e.g. ISTAx means ISTAD/ISTAB).

3.8.2 Message Transfer Modes

The HDLC controllers can be programmed to operate in various modes, which are different in the treatment of the HDLC frame in receive direction. Thus the receive data flow and the address recognition features can be programmed in a flexible way to satisfy different system requirements.

The structure of a D-channel two-byte address (LAPD) is shown below:

High Address Byte		Low Address Byte	
SAPI1, 2, SAPG	C/R 0	TEI 1, 2, TEIG	EA

For address recognition on the D-channel the ISAC-SX contains four programmable registers for individual SAPI and TEI values (SAP1, 2 and TEI1, 2), plus two fixed values for the “group” SAPI (SAPG = 'FE' or 'FC') and TEI (TEIG = 'FF').

The received C/R bit is excluded from the address comparison. EA is the address field extension bit which must be set to '1' according to HDLC LAPD.

The structure of a B-channel two-byte address is as follows:

High Address Byte		Low Address Byte	
RAH1, 2, Group Address	C/R 0	RAL1, 2, Group Address	

For address recognition on the B-channel the ISAC-SX contains four programmable registers for individual Receive Address High and Low values (RAH1, 2 and RAL1, 2), plus two fixed values for the High Address Byte (Group Address = 'FE' or 'FC') and one fixed value for the Low Address Byte (Group Address = 'FF').

The received C/R bit is excluded from the address comparison. EA is the address field extension bit which must be set to '1' according to HDLC LAPD.

Operating Modes

There are 5 different operating modes which can be selected via the mode selection bits MDS2-0 in the MODEx registers:

Non-Auto Mode (MDS2-0 = '01x')

Characteristics: Full address recognition with one-byte (MDS = '010') or two-byte (MDS = '011') address comparison

Description of Functional Blocks

All frames with valid addresses are accepted and the bytes following the address are transferred to the μ P via RFIFOx. Additional information is available in RSTAx.

Transparent mode 0 (MDS2-0 = '110').

Characteristics: no address recognition

Every received frame is stored in RFIFOx (first byte after opening flag to CRC field). Additional information can be read from RSTAx.

Transparent mode 1 (MDS2-0 = '111').

Characteristics: SAPI recognition (D-channel)
High byte address recognition (B-channel)

A comparison is performed on the first byte after the opening flag with SAP1, SAP2 and "group" SAPI (FE_H/FC_H) for D-channel, and with RAH1, RAH2 and group address (FE_H/FC_H) for B-channel. In the case of a match, all the following bytes are stored in RFIFOx. Additional information can be read from RSTAx.

Transparent mode 2 (MDS2-0 = '101').

Characteristics: TEI recognition (D-channel)
Low byte address recognition (B-channel)

A comparison is performed only on the second byte after the opening flag, with TEI1, TEI2 and group TEI (FF_H) for D-channel, and with RAL1 and RAL2 for B-channel. In case of a match the rest of the frame is stored in the RFIFOx. Additional information is available in RSTAx.

Extended transparent mode (MDS2-0 = '100').

Characteristics: fully transparent

In extended transparent mode fully transparent data transmission/reception without HDLC framing is performed i.e. without FLAG generation/recognition, CRC generation/check, bitstuffing mechanism. This allows user specific protocol variations.

Also refer to [Chapter 3.8.6](#).

3.8.3 Data Reception

3.8.3.1 Structure and Control of the Receive FIFO

The cyclic receive FIFO buffers with a length of 64 byte for D-channel and 128 byte for B-channel have variable FIFO block sizes (thresholds) of

- 4, 8, 16 or 32 bytes for D-channel and
- 8 or 16 bytes for B-channel

which can be selected by setting the corresponding RFBS bits in the EXMx registers. The variable block size allows an optimized HDLC processing concerning frame length, I/O throughput and interrupt load.

The transfer protocol between HDLC FIFO and microcontroller is block oriented with the

Description of Functional Blocks

microcontroller as master. The control of the data transfer between the CPU and the ISAC-SX is handled via interrupts (ISAC-SX → Host) and commands (Host → ISAC-SX).

There are three different interrupt indications in the ISTAx registers concerned with the reception of data:

- **RPF (Receive Pool Full)** interrupt, indicating that a data block of the selected length (EXMx.RFBS) can be read from RFIFOx. The message which is currently received exceeds the block size so further blocks will be received to complete the message.
- **RME (Receive Message End)** interrupt, indicating that the reception of one message is completed, i.e. either
 - a short message is received (message length ≤ the defined block size (EXMx.RFBS)) or
 - the last part of a long message is received (message length > the defined block size (EXMx.RFBS)) and is stored in the RFIFOx.
- **RFO (Receive Frame Overflow)** interrupt, indicating that a complete frame could not be stored in RFIFOx and is therefore lost as the RFIFOx is occupied. This occurs if the host fails to respond quickly enough to RPF/RME interrupts since previous data was not read by the host.

There are two control commands that are used with the reception of data:

- **RMC (Receive Message Complete)** command, telling the ISAC-SX that a data block has been read from the RFIFOx and the corresponding FIFO space can be released for new receive data.
- **RRES (Receiver Reset)** command, resetting the HDLC receiver and clearing the receive FIFO of any data (e.g. used before start of reception). It has to be used after a change of the message transfer mode. Pending interrupt indications of the receiver are not cleared by RRES, but have to be cleared by reading these interrupts.

Note: The significant interrupts and commands are underlined as only these are commonly used during a normal reception sequence.

The following description of the receive FIFO operation is illustrated in **Figure 72** for a RFIFOx block size (threshold) of 16 and 32 bytes.

The RFIFOx requests service from the microcontroller by setting a bit in the ISTAx register, which causes an interrupt (RPF, RME, RFO). The microcontroller then reads status information (RBCHx,RBCLx), data from the RFIFOx and then may change the receive FIFO block size (EXMx.RFBS). A block transfer is completed by the microcontroller via a receive message complete (CMDRx.RMC) command. This causes the space of the transferred bytes being released for new data and in case the frame was complete (RME) the reset of the receive byte counter RBC (RBCHx,RBCLx) ¹⁾.

¹⁾ If RMC is omitted, then no new interrupt can be generated.

Description of Functional Blocks

The total length of the frame is contained in the RBCHx and RBCLx registers which contain a 12 bit number (RBC11...0), so frames up to 4095 byte length can be counted. If a frame is longer than 4095 bytes, the RBCH.OV (overflow) bit will be set. The least significant bits of RBCLx contain the number of valid bytes in the last data block indicated by RME_x (length of last data block ≤ selected block size). **Table 18** shows which RBC bits contain the number of bytes in the last data block or number of complete data blocks respectively. If the number of bytes in the last data block is '0' the length of the last received block is equal to the block size.

Table 18 Receive Byte Count with RBC11...0 in the RBCHx/RBCLx Registers

EXMD1.RFBS bits (D-channel)	EXMB.RFBS bit (B-channel)	Selected block size	Number of	
			complete data blocks in	bytes in the last data block in
'00'	--	32 byte	RBC11...5	RBC4...0
'01'	'0'	16 byte	RBC11...4	RBC3...0
'10'	'1'	8 byte	RBC11...3	RBC2...0
'11'	--	4 byte	RBC11...2	RBC1...0

The transfer block size (EXM_x.RFBS) is 32 bytes for D-channel and 16 bytes for B-channel by default. If it is necessary to react to an incoming frame within the first few bytes the microcontroller can set the RFIFO_x block size to a smaller value. Each time a CMDR_x.RMC or CMDR_x.RRES command is issued, the RFIFO_x access controller sets its block size to the value specified in EXMR.RFBS, so the microcontroller has to write the new value for RFBS before the RMC command. When setting an initial value for RFBS before the first HDLC activities, a RRES command must be issued afterwards.

The RFIFO_x can hold any number of frames fitting in the 64 bytes (D-channel)/128 bytes (B-channel). At the end of a frame, the RSTAx byte is always appended.

All generated interrupts are inserted together with all additional information into a wait line to be individually passed to the host. For example if several data blocks have been received to be read by the host and the host acknowledges the current block, a new RPF or RME interrupt from the wait line is immediately generated to indicate new data.

Description of Functional Blocks

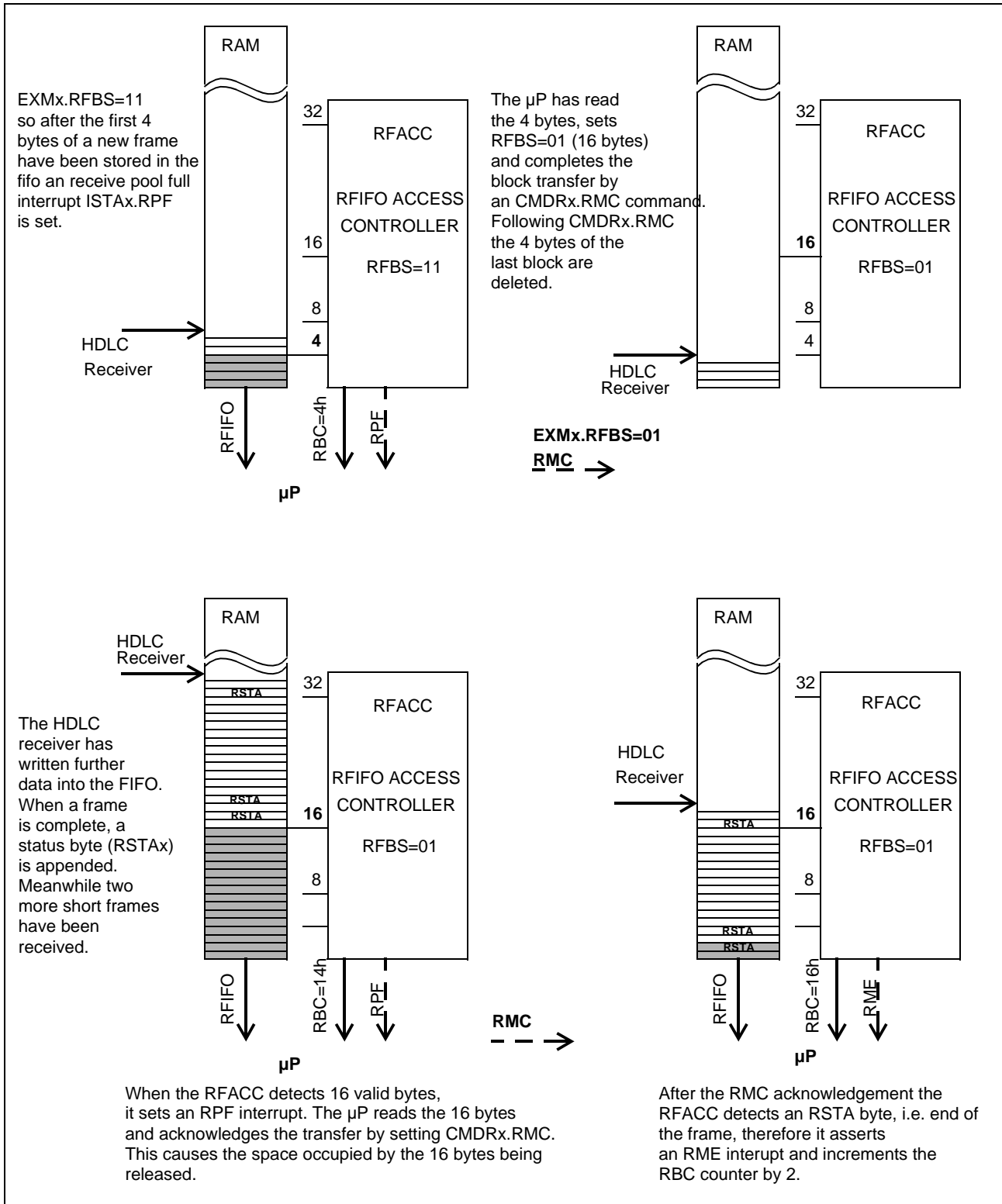

Figure 72 RFIFO Operation

Possible Error Conditions during Reception of Frames

If parts of a frame get lost because the receive FIFO is full, the Receive Data Overflow (RDO) byte in the RSTAx byte will be set. If a complete frame is lost, i.e. if the FIFO is full when a new frame is received, the receiver will assert a Receive Frame Overflow (RFO) interrupt.

The microcontroller sees a cyclic buffer, i.e. if it tries to read more data than available, it reads the same data again and again. On the other hand, if it doesn't read or doesn't want to read all data, they are deleted anyway after the RMC command.

If the microcontroller reads data without a prior RME or RPF interrupt, the content of the RFIFOx would not be corrupted, but new data is only transferred to the host as long as new valid data is available in the RFIFOx, otherwise the last data is read again and again.

The general procedures for a data reception sequence are outlined in the flow diagram in [Figure 73](#).

Description of Functional Blocks

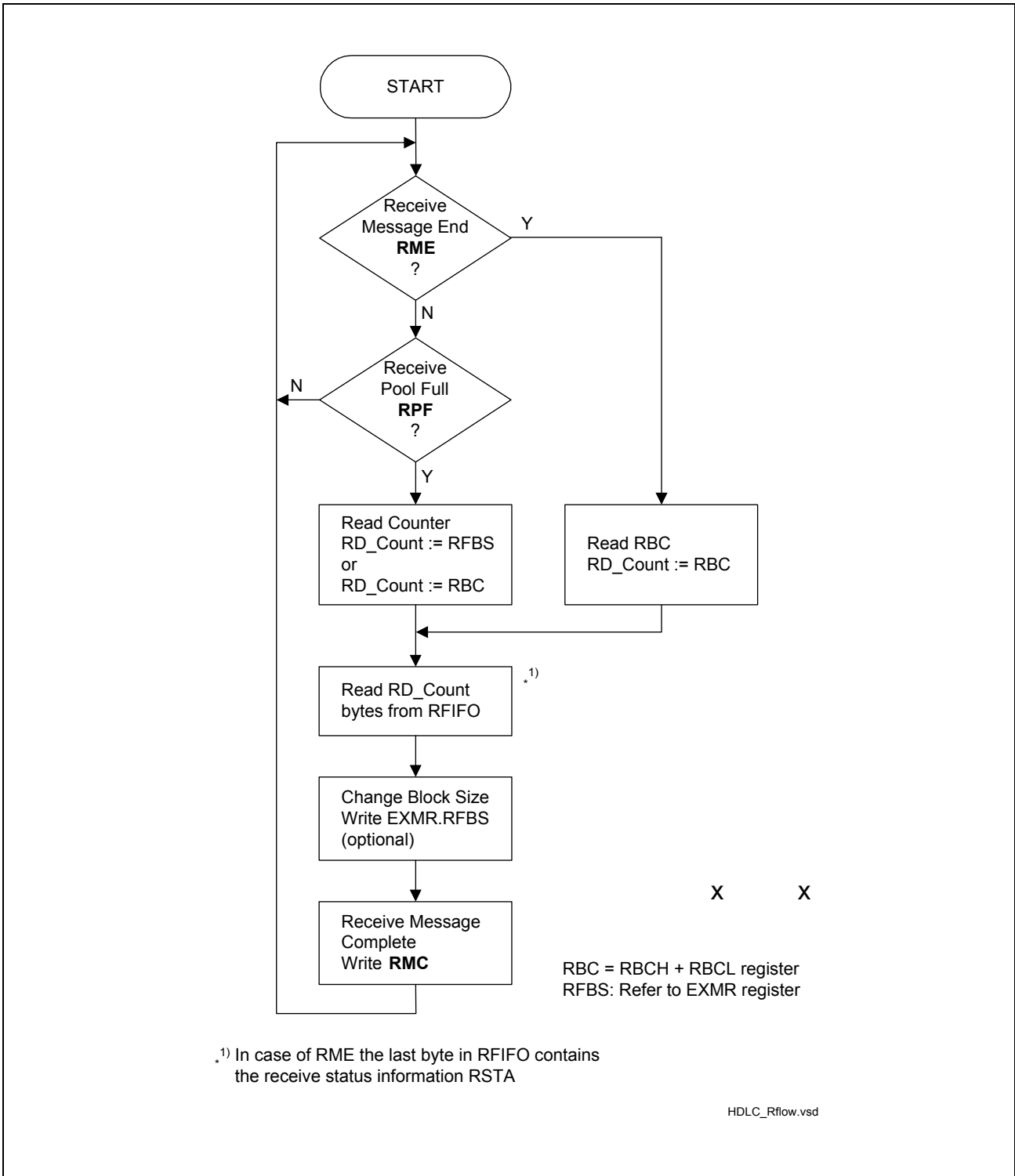

Figure 73 Data Reception Procedures

Description of Functional Blocks

Figure 74 gives an example of an interrupt controlled reception sequence, supposed that a long frame (68 byte) followed by two short frames (12 byte each) are received. The FIFO threshold (block size) is set to 32 byte in this example:

- After 32 byte of frame 1 have been received an RPF interrupt is generated to indicate that a data block can be read from the RFIFOx.
- The host reads the first data block from RFIFOx and acknowledges the reception by RMC. Meanwhile the second data block is received and stored in RFIFOx.
- The second 32 byte block is indicated by RPF which is read and acknowledged by the host as described before.
- The reception of the remaining 4 bytes plus RSTAx are indicated by RME (i.e. the receive status is always appended to the end of the frame).
- The host gets the number of bytes (COUNT = 5) from RBCLx/RBCHx and reads out the RFIFOx and optionally the status register RSTA. The frame is acknowledged by RMC.
- The second frame is received and indicated by RME interrupt.
- The host gets the number of bytes (COUNT = 13) from RBCLx/RBCHx and reads out the RFIFOx and optionally the status register. The RFIFOx is acknowledged by RMC.
- The third frame is transferred in the same way.

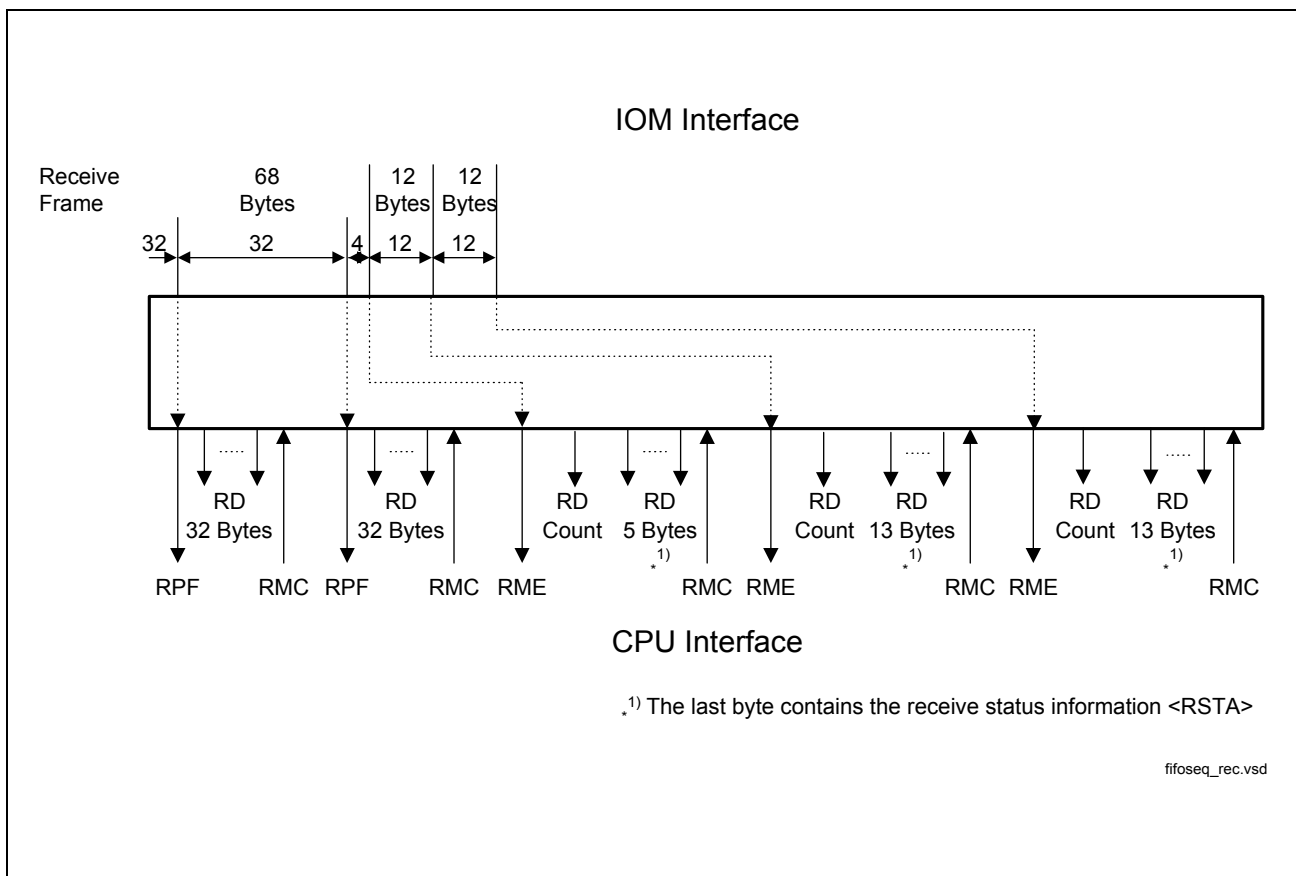

Figure 74 Reception Sequence Example

Description of Functional Blocks

3.8.3.2 Receive Frame Structure

The management of the received HDLC frames as affected by the different operating modes (see Chapter 3.8.2) is shown in Figure 75.

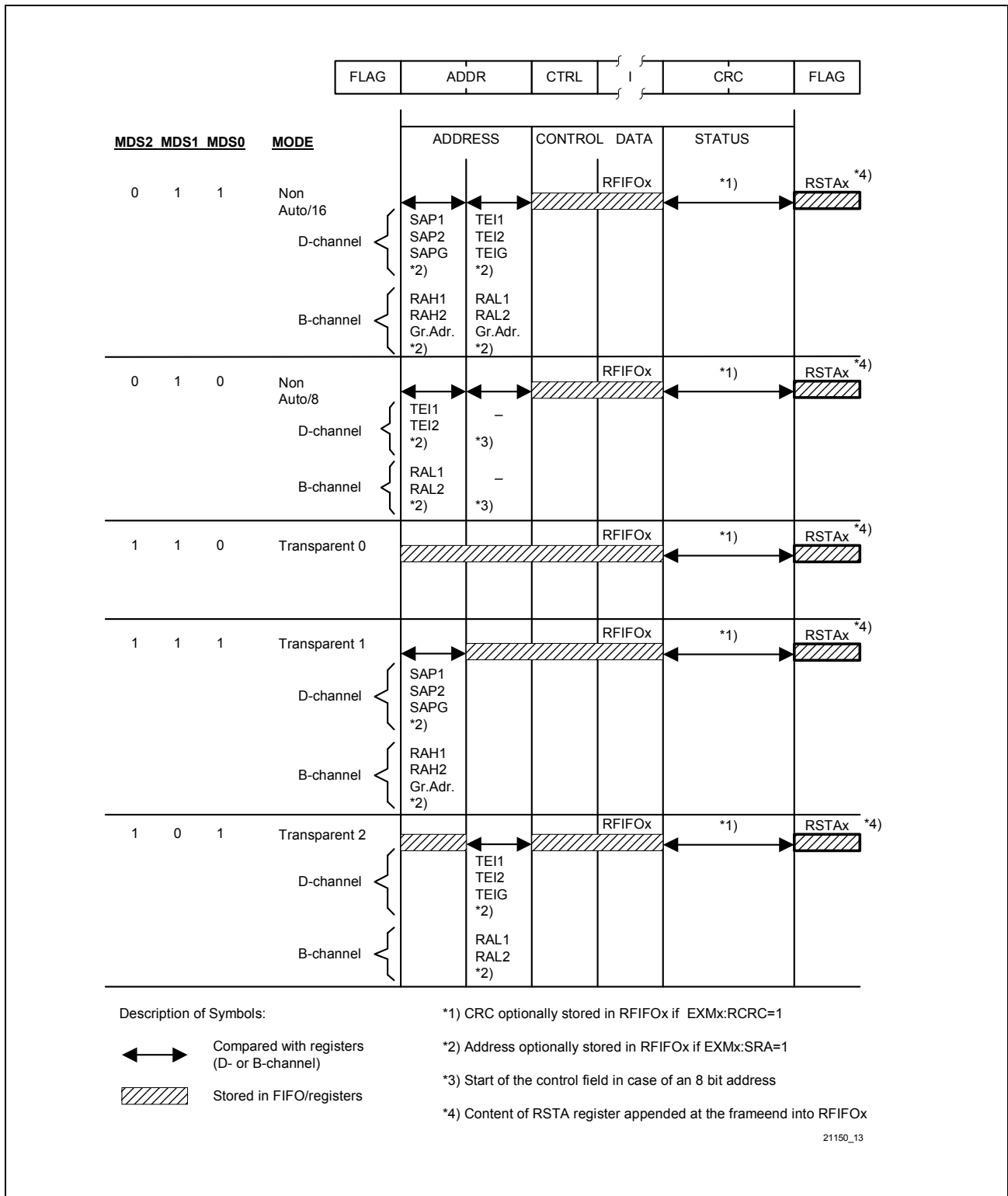

Figure 75 Receive Data Flow

Description of Functional Blocks

The ISAC-SX indicates to the host that a new data block can be read from the RFIFOx by means of an RPF interrupt (see previous chapter). User data is stored in the RFIFOx and information about the received frame is available in the RBCLx and RBCHx registers and the RSTAx bytes which are listed in [Table 19](#).

Table 19 Receive Information at RME Interrupt

Information	Register	Bit	Mode
Type of frame (Command/Response)	RSTAx	C/R	Non-auto mode, 2-byte address field Transparent mode 1
Recognition of SAPI	RSTAD RSTAB	SA1, 0 HA1, 0	Non-auto mode, 2-byte address field Transparent mode 1
Recognition of TEI	RSTAD RSTAB	TA LA	All except transparent mode 0
Result of CRC check (correct/incorrect)	RSTAx	CRC	All
Valid Frame	RSTAx	VFR	All
Abort condition detected (yes/no)	RSTAx	RAB	All
Data overflow during reception of a frame (yes/no)	RSTAx	RDO	All
Number of bytes received in RFIFO	RBCL	RBC4-0	All
Message length	RBCLx RBCHx	RBC11-0	All
RFIFO Overflow	RBCHx	OV	All

The RSTAx register is always appended in the RFIFOx as last byte to the end of a frame.
Note: The number of bytes received in RFIFOx depends on the selected receive FIFO threshold (EXMx.RFBS).

3.8.4 Data Transmission

3.8.4.1 Structure and Control of the Transmit FIFO

The cyclic transmit FIFO buffers with a length of 64 byte for D-channel and 128 byte for B-channel have FIFO block sizes (thresholds) of

- 16 or 32 bytes (programmable) for D-channel and
- 32 bytes for B-channels

which can be selected by setting the corresponding XFBS bits in the EXMx registers. There are three different interrupt indications in the ISTAx registers concerned with the transmission of data:

- **XPR (Transmit Pool Ready)** interrupt, indicating that a data block of up to 16 or 32 byte (D-channel), or 32 byte (B-channel) can be written to the XFIFOx (fixed block size). An XPR interrupt is generated either
 - after an XRES (Transmitter Reset) command (which is issued for example for frame abort) or
 - when a data block from the XFIFOx is transmitted and the corresponding FIFO space is released to accept further data from the host.
- **XDU (Transmit Data Underrun)** interrupt, indicating that the transmission of the current frame has been aborted (seven consecutive '1's are transmitted) as the XFIFOx holds no further transmit data. This occurs if the host fails to respond to an XPR interrupt quickly enough.
- Only valid for D-channel:
 - **XMR (Transmit Message Repeat)** interrupt, indicating that the transmission of the complete last frame has to be repeated as a collision on the S bus has been detected and the XFIFOx does not hold the first data bytes of the frame (collision after the 16th/32nd byte or after the 32nd byte of the frame, respectively).

The occurrence of an XDU or XMR interrupt clears the XFIFOx and an XMR interrupt is issued together with an XDU or XMR interrupt, respectively. Data cannot be written to the XFIFOx as long as an XDU/XMR interrupt is pending.

Three different control commands are used for transmission of data:

- **XTF (Transmit Transparent Frame)** command, telling the ISAC-SX that up to 16 or 32 byte (D-channel) or 32 (B-channel) have been written to the XFIFOx and should be transmitted. A start flag is generated automatically.
- **XME (Transmit Message End)** command, telling the ISAC-SX that the last data block written to the XFIFOx completes the corresponding frame and should be transmitted. This implies that according to the selected mode a frame end (CRC + closing flag) is generated and appended to the frame.
- **XRES (Transmitter Reset)** command, resetting the HDLC transmitter and clearing the transmit FIFO of any data. After an XRES command the transmitter always sends an abort sequence, i.e. this command can be used to abort a transmission. Pending

Description of Functional Blocks

interrupt indications of the transmitter are not cleared by XRES, but have to be cleared by reading these interutps.

Optionally two additional status conditions can be read by the host:

- **XDOV** (**Transmit Data Overflow**), indicating that the data block size has been exceeded, i.e. more than 16 or 32 byte (D-channel) or 32 byte (B-channel) were entered and data was overwritten.
- **XFW** (**Transmit FIFO Write Enable**), indicating that data can be written to the XFIFOx. This status flag may be polled instead of or in addition to XPR.

Note: The significant interrupts and commands are underlined as only these are usually used during a normal transmission sequence.

The XFIFO requests service from the microcontroller by setting a bit in the ISTAx register, which causes an interrupt (XPR, XDU, XMR). The microcontroller can then read the status register STARx (XFW, XDOV), write data in the FIFO and it can change the transmit FIFO block size (EXMD.XFBS, for D-channel only) if required.

The instant of the initiation of a transmit pool ready (XPR) interrupt after different transmit control commands is listed in **Table 20**.

Table 20 XPR Interrupt (availability of XFIFOx) after XTF, XME Commands

CMDRx Register	Transmit pool ready (XPR) interrupt initiated ...
XTF	as soon as the selected buffer size in the FIFOx is available.
XTF & XME	after the successful transmission of the closing flag. The transmitter always sends an abort sequence.
XME	as soon as the selected buffer size in the FIFO is available, two consecutive frames share flags.

When setting XME the transmitter appends the CRC and the endflag at the end of the frame. When XTF & XME has been set, the XFIFOx is locked until successful transmission of the current frame, so a consecutive XPR interrupt also indicates successful transmission of the frame whereas after XME or XTF the XPR interrupt is asserted as soon as there is space for one data block in the XFIFOx.

The transfer block size is 32 bytes for D- and B-channel by default, but sometimes, if the microcontroller has a high computational load, it is useful to increase the maximum reaction time for an XPR interrupt. However, the threshold can only be changed for D-channel. The maximum reaction time is:

$$t_{\max} = (\text{XFIFOx size} - \text{XFBS}) / \text{data transmission rate}$$

With a selected FIFO block size of 16 bytes (D-channel only) an XPR interrupt indicates when a transmit FIFO space of at least 16 bytes is available to accept further data, i.e. there are still a maximum of 48 bytes (64 bytes - 16 bytes) to be transmitted. With a 32 bytes

Description of Functional Blocks

block size (D- or B-channel) the XPR is initiated when a transmit FIFO space of at least 32 bytes is available to accept further data, i.e. there are still a maximum of 32 bytes (D-channel: 64 bytes - 32 bytes) or 96 bytes (B-channel: 128 bytes - 32 bytes) to be transmitted. The maximum reaction time for the smaller block size is 50% higher with the trade-off of a doubled interrupt load. With a selected block size an XPR always indicates the available space in the XFIFOx, so any number of bytes smaller than the selected XFBS may be stored in the FIFO during one "write block" access cycle.

Similar to RFBS for the receive FIFO, a new setting of XFBS takes effect after the next XTF, XME or XRES command. XRES resets the XFIFOx.

The XFIFOx can hold any number of frames fitting in the 64 bytes (D-channel) or 128 bytes (B-channel), respectively.

Possible Error Conditions During Transmission of Frames

If the transmitter sees an empty FIFO, i.e. if the microcontroller doesn't react fast enough to an XPR interrupt, an XDU (transmit data underrun) interrupt will be generated. If the HDLC channel becomes unavailable during transmission the transmitter tries to repeat the current frame as specified in the LAPD protocol. This is impossible after the first data block has been sent (16 or 32 bytes for D-channel; 32 byte for B-channel), in this case an XMR transmit message repeat interrupt is set and the microcontroller has to send the whole frame again.

Both XMR and XDU interrupts cause a reset of the XFIFOx. The XFIFOx is locked while an XMR or XDU interrupt is pending, i.d. all write actions of the microcontroller will be ignored as long as the microcontroller hasn't read the ISTAx register with the set XDU, XMR interrupts.

If the microcontroller writes more data than allowed (block size), then the data in the XFIFOx will be corrupted and the STARx.XDOV bit is set. If this happens, the microcontroller has to abort the transmission by CMDRx.XRES and start new.

The general procedures for a data transmission sequence are outlined in the flow diagram in [Figure 76](#).

Description of Functional Blocks

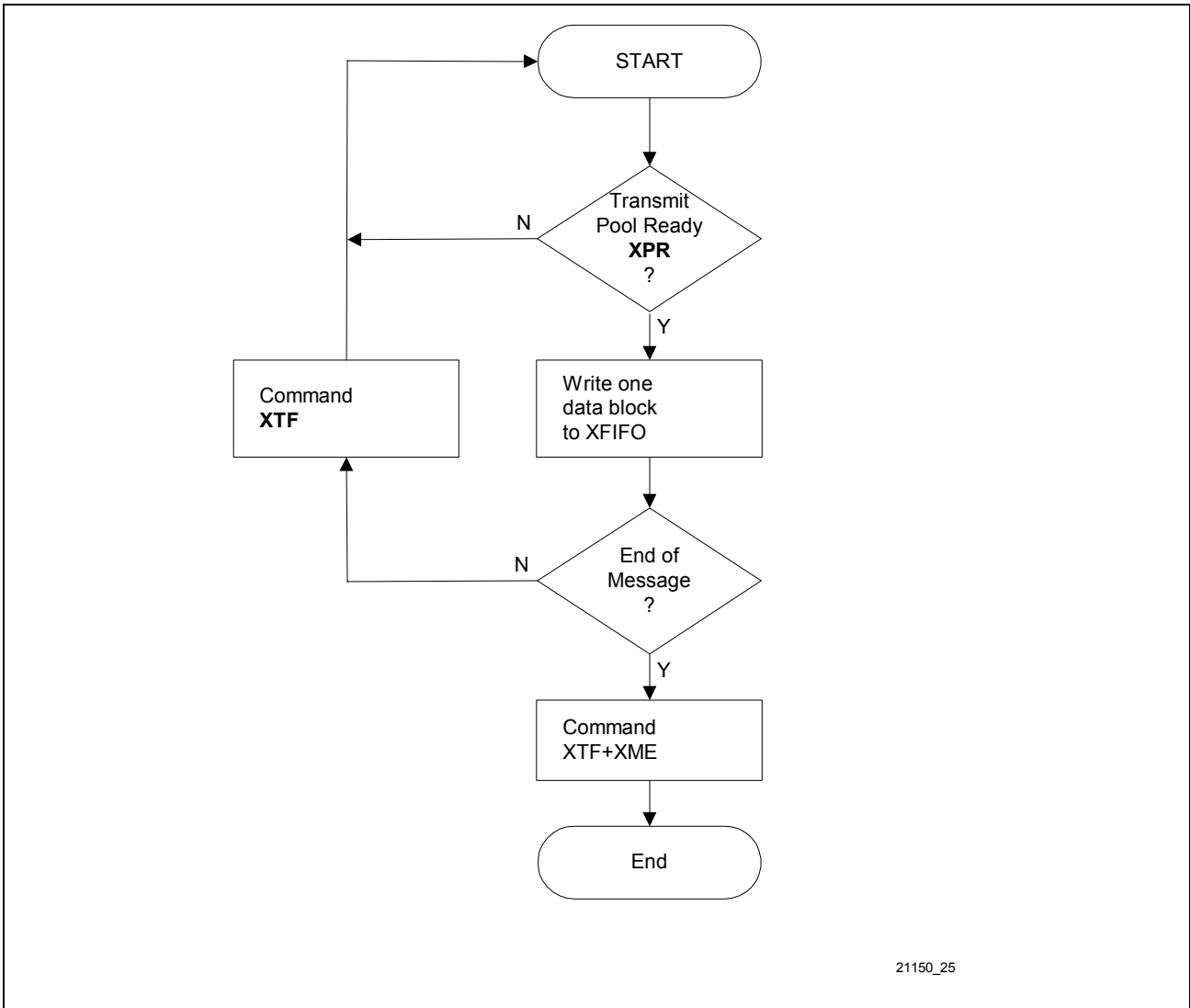

Figure 76 Data Transmission Procedure

Description of Functional Blocks

The following description gives an example for the transmission of a 76 byte frame with a selected block size of 32 byte:

- The host writes 32 bytes to the XFIFOx, issues an XTF command and waits for an XPR interrupt in order to continue with entering data.
- The ISAC-SX immediately issues an XPR interrupt (as remaining XFIFOx space is not used) and starts transmission.
- Due to the XPR interrupt the host writes the next 32 bytes to the XFIFOx, followed by the XTF command, and waits for XPR.
- As soon as the last byte of the first block is transmitted, the ISAC-SX releases an XPR (XFIFOx space of first data block is free again) and continues transmitting the second block.
- The host writes the remaining 12 bytes of the frame to the XFIFOx and issues the XTF command together with XME to indicate that this is the end of frame.
- After the last byte of the frame has been transmitted the ISAC-SX releases an XPR interrupt and the host may proceed with transmission of a new frame.

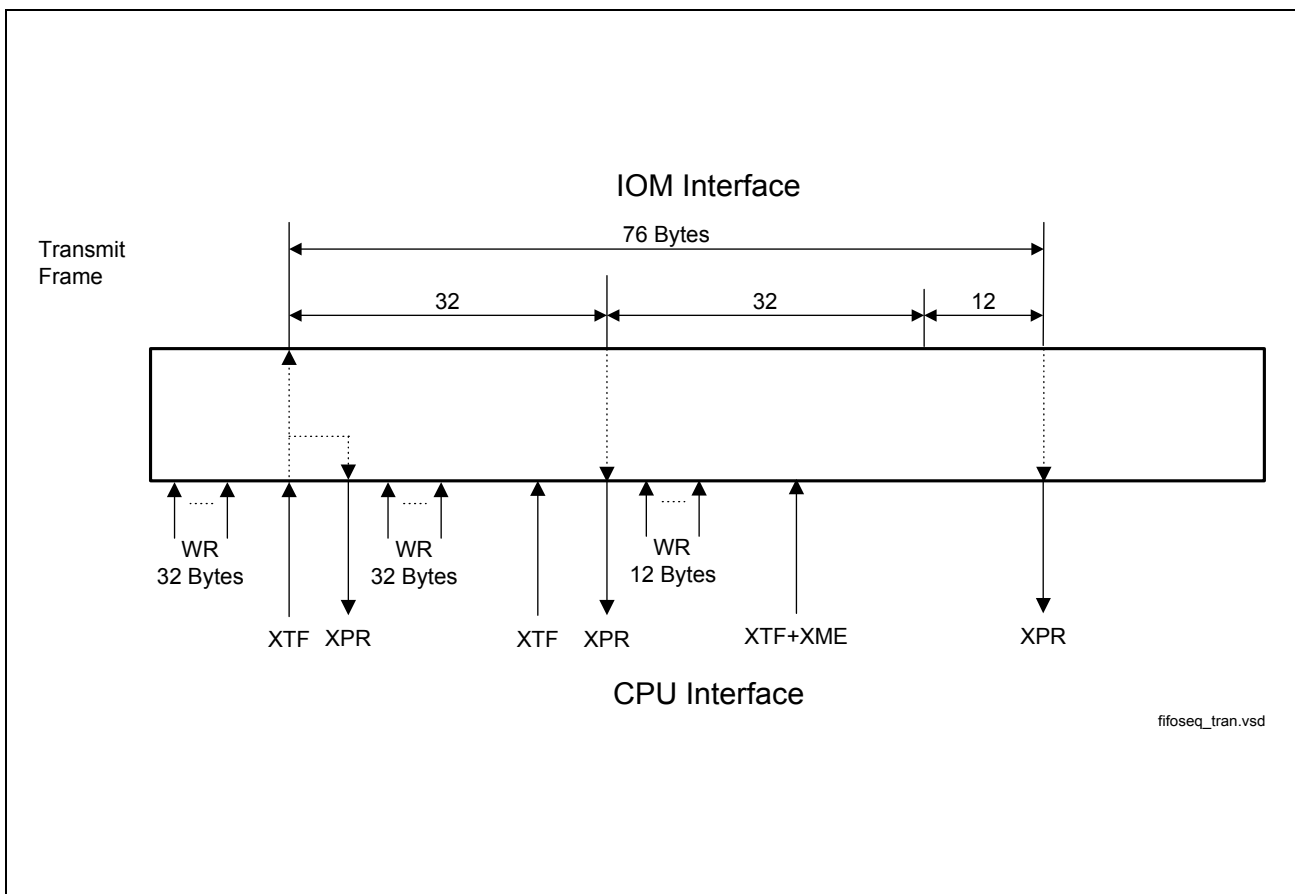

Figure 77 Transmission Sequence Example

3.8.4.2 Transmit Frame Structure

The transmission of transparent frames (XTF command) is shown in [Figure 78](#).

For transparent frames, the whole frame including address and control field must be written to the XFIFOx. The host configures whether the CRC is generated and appended to the frame (default) or not (selected in EXMx.XCRC).

Further, the host selects the interframe time fill signal which is transmitted between HDCL frames (EXMx.ITF). One option is to send continuous flags ('01111110'), however if D-channel access handling (collision resolution on the S bus) is required, the signal must be set to idle (continuous '1's are transmitted). Reprogramming of ITF takes effect only after the transmission of the current frame has been completed or after an XRES command.

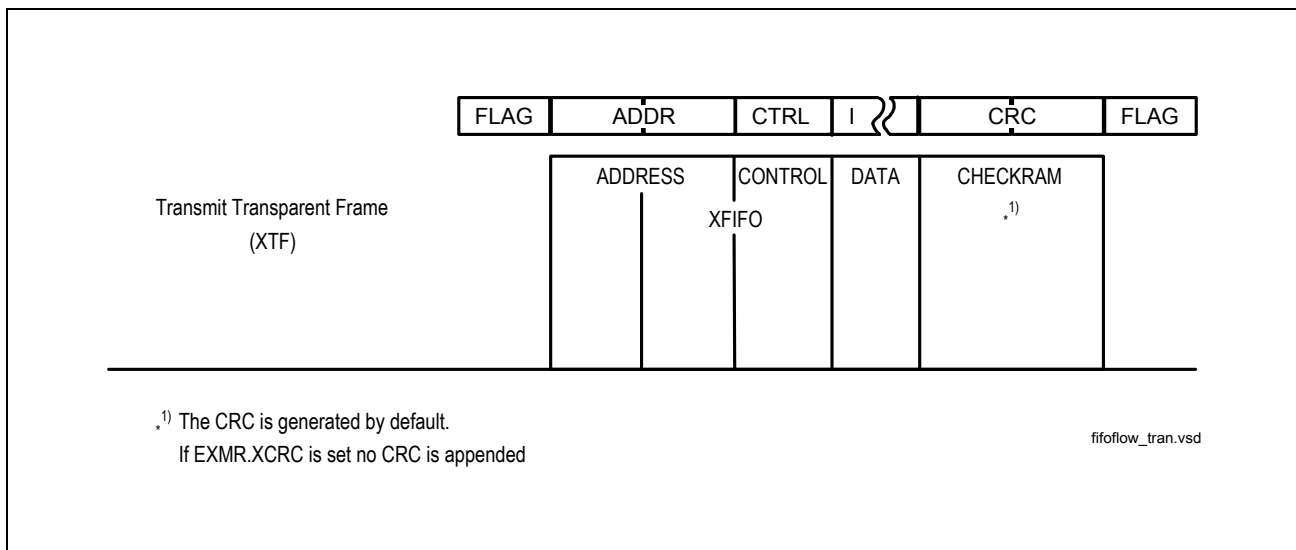

Figure 78 Transmit Data Flow

3.8.5 Access to IOM-2 Channels

By setting the enable HDLC data bits (EN_D, EN_B1H, EN_B2H) in the DCI_CR register (D-channel) and in the BCH_CR register (B-channel) the HDLC controller can access the D, B1 and B2 channels or any combination of them. In all modes (except extended transparent mode) transmission always works frame aligned, i.e. it starts with the first selected channel, whereas reception searches for a flag anywhere in the serial data stream.

3.8.6 Extended Transparent Mode

This non-HDLC mode is selected by setting MODE2...0 to '100'. In extended transparent mode fully transparent data transmission/reception without HDLC framing is performed i.e. without FLAG generation/recognition, CRC generation/check, bitstuffing mechanism. This allows user specific protocol variations.

Description of Functional Blocks

Transmitter

The transmitter sends the data out of the FIFO without manipulation. Transmission is always IOM-2 frame aligned and byte aligned, i.e. transmission starts in the first selected channel (B1, B2, D, according to the setting of register DCI_CR or BCH_CR in the IOM-2 Handler) of the next IOM-2 frame.

The FIFO indications and commands are the same as in other modes.

If the microcontroller sets XTF & XME the transmitter responds with an XPR interrupt after sending the last byte, then it returns to its idle state (sending continuous '1').

If the collision detection is enabled in D-channel (MODE.DIM = '0x1') the stop go bit (S/G) can be used as clear to send indication as in any other mode. If the S/G bit is set to '1' (stop) during transmission the transmitter responds always with an XMR (transmit message repeat) interrupt.

If the microcontroller fails to respond to a XPR interrupt in time and the transmitter runs out of data then it will assert an XDU (transmit data underrun) interrupt.

Receiver

The reception is IOM-2 frame aligned and byte aligned, like transmission, i.e. reception starts in the first selected channel (B1, B2, D, according to the setting of registers DCI_CR and BCH_CR in the IOM-2 Handler) of the next IOM-2 frame. The FIFO indications and commands are the same as in others modes.

All incoming data bytes are stored in the RFIFOx and is additionally made available in RSTAx. If the FIFO is full an RFO interrupt is asserted (EXMx.SRA = '0').

Note: In the extended transparent mode the EXMx register has to be set to 'xxx00000'

3.8.7 HDLC Controller Interrupts

The cause of an interrupt related to the HDLC controllers is indicated in the ISTA register by the ICD bit for D-channel and ICB for B-channel. These bits point to the different interrupt sources of the HDLC controllers in the ISTAD and ISTAB registers. The individual interrupt sources of the HDLC controllers during reception and transmission of data are explained in [Chapter 3.8.3.1](#) or [Chapter 3.8.4.1](#) respectively.

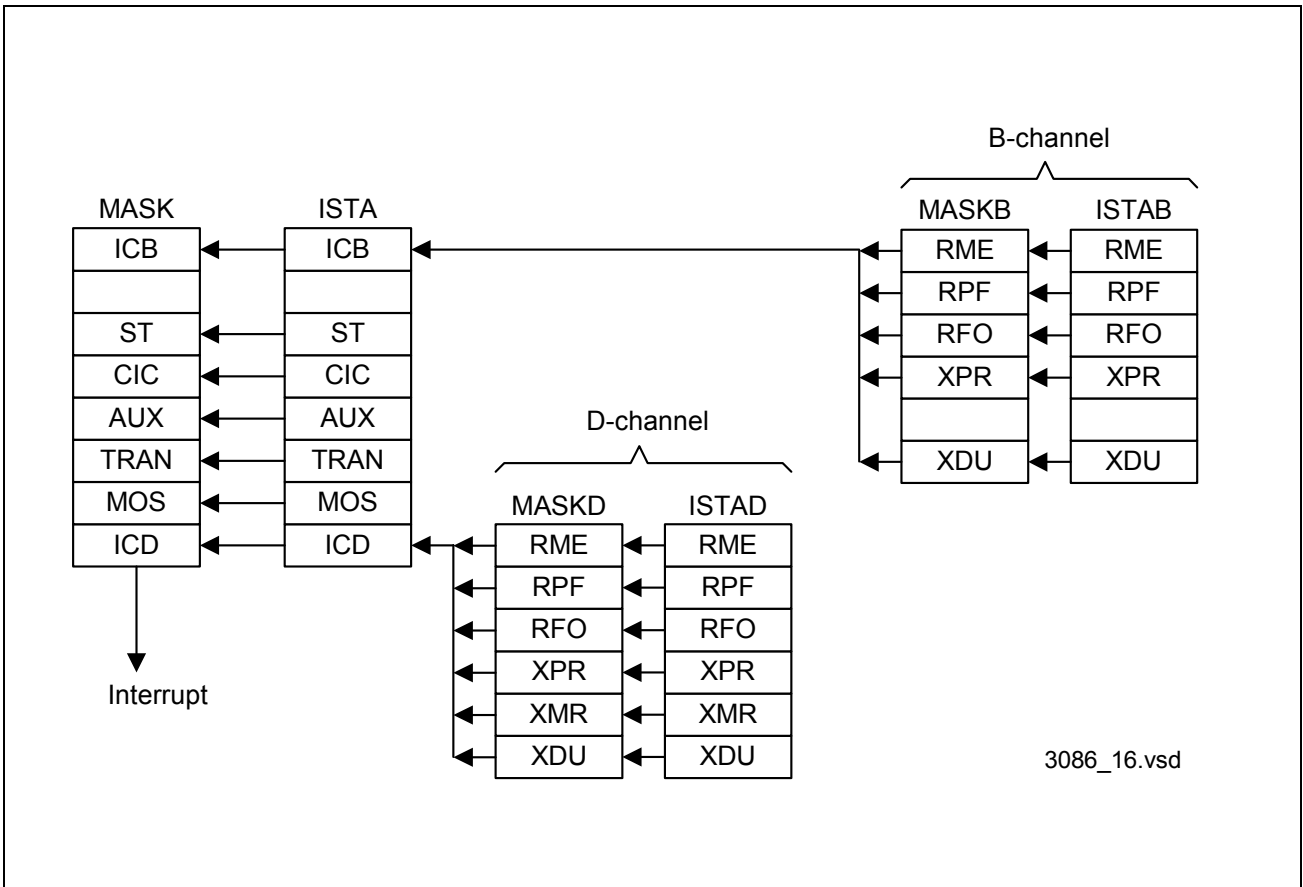

Figure 79 Interrupt Status Registers of the HDLC Controllers

Each interrupt source in the ISTAD and ISTAB registers can selectively be masked by setting the corresponding bit in MASKD/MASKB to “1”.

3.9 Test Functions

The ISAC-SX provides test and diagnostic functions for the S-interface, the D-channel and each of the two B-channels:

- Digital loop via TLP (Test Loop, TMD and TMB registers) command bit (**Figure 80**): The TX path of layer 2 is internally connected with the RX path of layer 2. The output from layer 1 (S/T) on DD is ignored. This is used for testing ISAC-SX functionality excluding layer 1 (loopback between XFIFOx and RFIFOx).

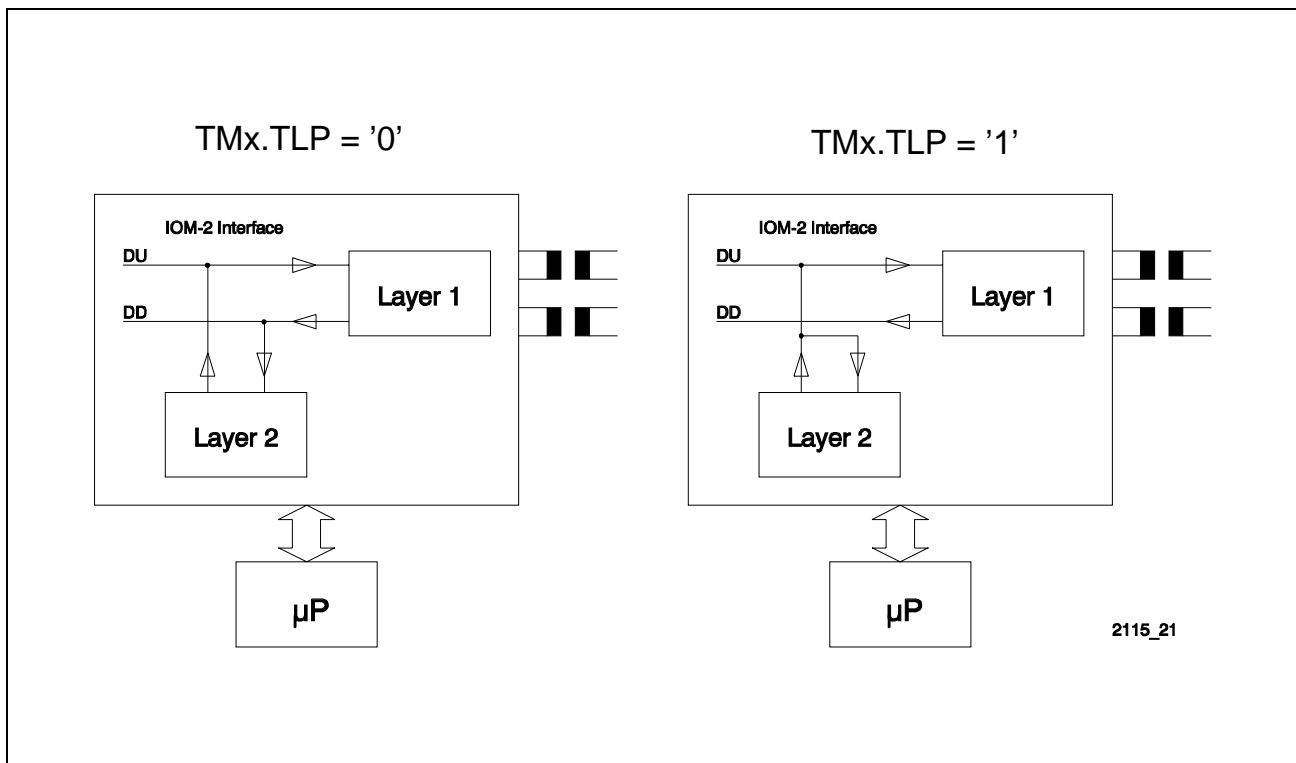

Figure 80 Layer 2 Test Loops

- Test of layer-2 functions while disabling all layer-1 functions and pins associated with them (including clocking) via bit TR_CONF0.DIS_TR. The HDLC controllers can still operate via IOM-2. DCL and FSC pins become input.

Description of Functional Blocks

- loop at the analog end of the S interface;

TE / LT-T mode

Test loop 3 is activated with the C/I channel command Activate Request Loop (ARL). An S interface is not required since INFO3 is looped back internally to the receiver. When the receiver has synchronized itself to this signal, the message "Test Indication" (or "Awake Test Indication") is delivered in the C/I channel. No signal is transmitted over the S interface.

In the test loop mode the S interface awake detector is enabled, i.e. if a level is detected (e.g. Info 2/Info 4) this will be reported by the Resynchronization Indication (RSY). The loop function is not effected by this condition and the internally generated 192-kHz line clock does not depend on the signal received at the S interface.

NT / LT-S mode

Test loop 2 is likewise activated over the IOM-2 interface with Activate Request Loop (ARL). No S line is required. INFO4 is looped back internally to the receiver and also sent to the S interface. When the receiver is synchronized, the message "AIU" is sent in the C/I channel.

- transmission of special test signals on the S/T interface according to the modified AMI code are initiated via a C/I command written in CIX0 register.

Two kinds of test signals may be sent by the ISAC-SX:

- single pulses and
- continuous pulses.

The single pulses are of alternating polarity, one S interface bit period wide, 0.25 ms apart, with a repetition frequency of 2 kHz. Single pulses can be sent in all applications. The corresponding C/I command in TE, LT-S and LT-T applications is TM1.

Continuous pulses are likewise of alternating polarity, one S-interface bit period wide, but they are sent continuously. The repetition frequency is 96 kHz. Continuous pulses may be transmitted in all applications. This test mode is entered in LT-S, LT-T and TE applications with the C/I command TM2.

4 Detailed Register Description

The register mapping of the ISAC-SX is shown in [Figure 81](#).

FFh	(Not used)
80h	
70h	B-channel
60h	Interrupt, General Configuration
40h	IOM-2 and MONITOR Handler
30h	Transceiver, Auxiliary Interface
00h	D- and C/I-channel

3086_04

Figure 81 Register Mapping of the ISAC-SX

The register address range from 00_H-2F_H is assigned to the D-channel HDLC controller and the C/I-channel handler.

The register set ranging from 30_H-3F_H pertains to the transceiver and auxiliary interface registers.

Detailed Register Description

The address range from 40_H-5B_H is assigned to the IOM handler with the registers for timeslot and data port selection (TSDP) and the control registers (CR) for the transceiver data (TR), Monitor data (MON), HDLC/CI data (HCI) and controller access data (CDA), serial data strobe signal (SDS), IOM interface (IOM) and synchronous transfer interrupt (STI).

The address range from 5C_H-5F_H pertains to the MONITOR handler.

General interrupt and configuration registers are contained in the address range 60_H-65_H.

The address range 70_H-7F_H is assigned to the B-channel FIFOs and HDLC controller.

The register summaries of the ISAC-SX are shown in the following tables containing the abbreviation of the register name and the register bits, the register address, the reset values and the register type (Read/Write). A detailed register description follows these register summaries.

The register summaries and the description are sorted in ascending order of the register address.

D-channel HDLC, C/I-channel Handler

Name	7	6	5	4	3	2	1	0	ADDR	R/W	RES
RFIFOD	D-Channel Receive FIFO								00 _H -1F _H	R	
XFIFOD	D-Channel Transmit FIFO								00 _H -1F _H	W	
ISTAD	RME	RPF	RFO	XPR	XMR	XDU	0	0	20 _H	R	10 _H
MASKD	RME	RPF	RFO	XPR	XMR	XDU	1	1	20 _H	W	FF _H
STARD	XDOV	XFW	0	0	RACI	0	XACI	0	21 _H	R	40 _H
CMDRD	RMC	RRES	0	STI	XTF	0	XME	XRES	21 _H	W	00 _H
MODED	MDS2	MDS1	MDS0	0	RAC	DIM2	DIM1	DIM0	22 _H	R/W	C0 _H
EXMD1	XFBS	RFBS		SRA	XCRC	RCRC	0	ITF	23 _H	R/W	00 _H
TIMR1	CNT			VALUE					24 _H	R/W	00 _H
SAP1	SAPI1						0	MHA	25 _H	W	FC _H
SAP2	SAPI2						0	MLA	26 _H	W	FC _H

Detailed Register Description

RBCLD	RBC7							RBC0	26 _H	R	00 _H
RBCHD	0	0	0	OV	RBC11			RBC8	27 _H	R	00 _H
TEI1	TEI1							EA1	27 _H	W	FF _H
TEI2	TEI2							EA2	28 _H	W	FF _H
RSTAD	VFR	RDO	CRC	RAB	SA1	SA0	C/R	TA	28 _H	R	0F _H
TMD	0	0	0	0	0	0	0	TLP	29 _H	R/W	00 _H
	reserved								2A-2D _H		
CIR0	CODR0			CIC0	CIC1	S/G	BAS		2E _H	R	F3 _H
CIX0	CODX0			TBA2	TBA1	TBA0	BAC		2E _H	W	FE _H
CIR1	CODR1					CICW	CI1E		2F _H	R	FE _H
CIX1	CODX1					CICW	CI1E		2F _H	W	FE _H

Transceiver, Auxiliary Interface

NAME	7	6	5	4	3	2	1	0	ADDR	R/W	RES
TR_CONF0	DIS_TR	BUS	EN_ICV	0	L1SW	0	EXLP	LDD	30 _H	R/W	01 _H
TR_CONF1	0	RPLL_ADJ	EN_SFSC	0	0	x	x	x	31 _H	R/W	
TR_CONF2	DIS_TX	PDS	0	RLP	0	0	SGP	SGD	32 _H	R/W	80 _H
TR_STA	RINF		0	ICV	0	FSYN	0	LD	33 _H	R	00 _H
TR_CMD	XINF			DPRIO	TDDIS	PD	LP_A	0	34 _H	R/W	08 _H
SQRR1	MSYN	MFEN	0	0	SQR11	SQR12	SQR13	SQR14	35 _H	R	40 _H
SQXR1	0	MFEN	0	0	SQX11	SQX12	SQX13	SQX14	35 _H	W	4F _H
SQRR2	SQR21	SQR22	SQR23	SQR24	SQR31	SQR32	SQR33	SQR34	36 _H	R	00 _H

Detailed Register Description

Transceiver, Auxiliary Interface

NAME	7	6	5	4	3	2	1	0	ADDR	R/W	RES
SQXR2	SQX21	SQX22	SQX23	SQX24	SQX31	SQX32	SQX33	SQX34	36 _H	W	00 _H
SQRR3	SQR41	SQR42	SQR43	SQR44	SQR51	SQR52	SQR53	SQR54	37 _H	R	00 _H
SQXR3	SQX41	SQX42	SQX43	SQX44	SQX51	SQX52	SQX53	SQX54	37 _H	W	00 _H
ISTATR	0	x	x	x	LD	RIC	SQC	SQW	38 _H	R	00 _H
MASKTR	1	1	1	1	LD	RIC	SQC	SQW	39 _H	R/W	FF _H
TR_ MODE	0	0	0	0	DCH_ INH	MODE 2	MODE 1	MODE 0	3A _H	R/W	00 _H
	reserved								3B _H		
ACFG1	OD7	OD6	OD5	OD4	OD3	OD2	OD1	OD0	3C _H	R/W	00 _H
ACFG2	A7SEL	A5SEL	FBS	A4SEL	ACL	LED	EL1	EL0	3D _H	R/W	00 _H
AOE	OE7	OE6	OE5	OE4	OE3	OE2	OE1	OE0	3E _H	R/W	FF _H
ARX	AR7	AR6	AR5	AR4	AR3	AR2	AR1	AR0	3F _H	R	
ATX	AT7	AT6	AT5	AT4	AT3	AT2	AT1	AT0	3F _H	W	00 _H

IOM Handler (Timeslot , Data Port Selection, CDA Data and CDA Control Register)

Name	7	6	5	4	3	2	1	0	ADDR	R/W	RES
CDA10	Controller Data Access Register (CH10)								40 _H	R/W	FF _H
CDA11	Controller Data Access Register (CH11)								41 _H	R/W	FF _H
CDA20	Controller Data Access Register (CH20)								42 _H	R/W	FF _H
CDA21	Controller Data Access Register (CH21)								43 _H	R/W	FF _H
CDA_ TSDP10	DPS	0	0	TSS					44 _H	R/W	00 _H

Detailed Register Description

CDA_TSDP11	DPS	0	0	TSS				45H	R/W	01H	
CDA_TSDP20	DPS	0	0	TSS				46H	R/W	80H	
CDA_TSDP21	DPS	0	0	TSS				47H	R/W	81H	
BCH_TSDP_BC1	DPS	0	0	TSS				48H	R/W	80H	
BCH_TSDP_BC2	DPS	0	0	TSS				49H	R/W	81H	
reserved							4AH				
reserved							4BH				
TR_TSDP_BC1	DPS	0	0	TSS				4CH	R/W		
TR_TSDP_BC2	DPS	0	0	TSS				4DH	R/W		
CDA1_CR	0	0	EN_TBM	EN_I1	EN_I0	EN_O1	EN_O0	SWAP	4EH	R/W	00H
CDA2_CR	0	0	EN_TBM	EN_I1	EN_I0	EN_O1	EN_O0	SWAP	4FH	R/W	00H

IOM Handler (Control Registers, Synchronous Transfer Interrupt Control), MONITOR Handler

Name	7	6	5	4	3	2	1	0	ADDR	R/W	RES
TR_CR (CI_CS=0)	EN_D	EN_B2R	EN_B1R	EN_B2X	EN_B1X	CS2-0			50H	R/W	

Detailed Register Description

TRC_CR (CI_CS=1)	0	0	0	0	0	CS2-0			50 _H	R/W	
BCH_CR	DPS_D	0	EN_D	EN_BC2	EN_BC1	CS2-0			51 _H	R/W	80 _H
	reserved								52 _H		
DCI_CR (CI_CS=0)	DPS_CI1	EN_CI1	D_EN_D	D_EN_B2	D_EN_B1	CS2-0			53 _H	R/W	
DCIC_CR (CI_CS=1)	0	0	0	0	0	CS2-0			53 _H	R/W	
MON_CR	DPS	EN_MON	0	0	0	CS2-0			54 _H	R/W	
SDS1_CR	ENS_TSS	ENS_TSS+1	ENS_TSS+3	TSS					55 _H	R/W	00 _H
SDS2_CR	ENS_TSS	ENS_TSS+1	ENS_TSS+3	TSS					56 _H	R/W	00 _H
IOM_CR	SPU	DIS_AW	CI_CS	TIC_DIS	EN_BCL	CLKM	DIS_OD	DIS_IOM	57 _H	R/W	08 _H
STI	STOV ₂₁	STOV ₂₀	STOV ₁₁	STOV ₁₀	STI ₂₁	STI ₂₀	STI ₁₁	STI ₁₀	58 _H	R	00 _H
ASTI	0	0	0	0	ACK ₂₁	ACK ₂₀	ACK ₁₁	ACK ₁₀	58 _H	W	00 _H
MSTI	STOV ₂₁	STOV ₂₀	STOV ₁₁	STOV ₁₀	STI ₂₁	STI ₂₀	STI ₁₁	STI ₁₀	59 _H	R/W	FF _H
SDS_CONF	0	0	0	0	DIOM_INV	DIOM_SDS	SDS2_BCL	SDS1_BCL	5A _H	R/W	00 _H
MCDA	MCDA21		MCDA20		MCDA11		MCDA10		5B _H	R	FF _H
MOR	MONITOR Receive Data								5C _H	R	FF _H
MOX	MONITOR Transmit Data								5C _H	W	FF _H
MOSR	MDR	MER	MDA	MAB	0	0	0	0	5D _H	R	00 _H

Detailed Register Description

MOCR	MRE	MRC	MIE	MXC	0	0	0	0	5E _H	R/W	00 _H
MSTA	0	0	0	0	0	MAC	0	TOUT	5F _H	R	00 _H
MCONF	0	0	0	0	0	0	0	TOUT	5F _H	W	00 _H

Interrupt, General Configuration Registers

NAME	7	6	5	4	3	2	1	0	ADDR	R/W	RES
ISTA	ICB	0	ST	CIC	AUX	TRAN	MOS	ICD	60 _H	R	00 _H
MASK	ICB	1	ST	CIC	AUX	TRAN	MOS	ICD	60 _H	W	FF _H
AUXI	0	0	EAW	WOV	TIN2	TIN1	INT1	INT0	61 _H	R	00 _H
AUXM	1	1	EAW	WOV	TIN2	TIN1	INT1	INT0	61 _H	W	FF _H
MODE1	0	0	0	WTC1	WTC2	CFS	RSS2	RSS1	62 _H	R/W	00 _H
MODE2	0	0	0	0	INT_ POL	0	0	PPSDX	63 _H	R/W	00 _H
ID	0	0	DESIGN						64 _H	R	01 _H
SRES	RES_ CI	RES_ BCH	0	RES_ MON	RES_ DCH	RES_ IOM	RES_ TR	RES_ RSTO	64 _H	W	00 _H
TIMR2	TMD	0	CNT						65 _H	R/W	00 _H
	reserved								66 _H - 6F _H		

B-channel HDLC Control Registers

Name	7	6	5	4	3	2	1	0	ADDR	R/W	RES
ISTAB	RME	RPF	RFO	XPR	0	XDU	0	0	70 _H	R	10 _H
MASKB	RME	RPF	RFO	XPR	1	XDU	1	1	70 _H	W	FF _H
STARB	XDOV	XFW	0	0	RACI	0	XACI	0	71 _H	R	40 _H

Detailed Register Description

CMDRB	RMC	RRES	0	0	XTF	0	XME	XRES	71 _H	W	00 _H
MODEB	MDS2	MDS1	MDS0	0	RAC	0	0	0	72 _H	R/W	C0 _H
EXMB	1	1	RFBS	SRA	XCRC	RCRC	0	ITF	73 _H	R/W	C0 _H
	reserved								74 _H		
RAH1	RAH1						0	MHA	75 _H	W	00 _H
RAH2	RAH2						0	MLA	76 _H	W	00 _H
RBCLB	RBC7							RBC0	76 _H	R	00 _H
RBCHB	0	0	0	OV	RBC11			RBC8	77 _H	R	00 _H
RAL1	RAL1								77 _H	W	00 _H
RAL2	RAL2								78 _H	W	00 _H
RSTAB	VFR	RDO	CRC	RAB	HA1	HA0	C/R	LA	78 _H	R	0E _H
TMB	0	0	0	0	0	0	0	TLP	79 _H	R/W	00 _H
RFIFOB	B-Channel Receive FIFO								7A _H	R	
XFIFOB	B-Channel Transmit FIFO								7A _H	W	
	reserved								7B _H - 7F _H		

4.1 D-channel HDLC Control and C/I Registers

4.1.1 RFIFOD - Receive FIFO D-Channel

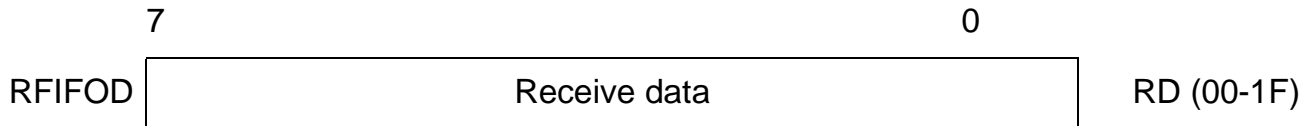

A read access to any address within the range 00h-1Fh gives access to the “current” FIFO location selected by an internal pointer which is automatically incremented after each read access. This allows for the use of efficient “move string” type commands by the microcontroller.

The RFIFOD contains up to 32 bytes of received data.

After an ISTAD.RPF interrupt, a complete data block is available. The block size can be 4, 8, 16 or 32 bytes depending on the EXMD2.RFBS setting.

After an ISTAD.RME interrupt, the number of received bytes can be obtained by reading the RBCLD register.

4.1.2 XFIFOD - Transmit FIFO D-Channel

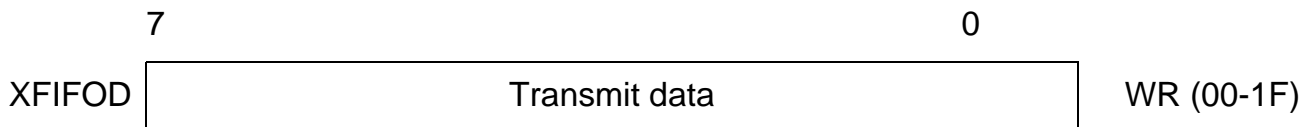

A write access to any address within the range 00-1F_H gives access to the “current” FIFO location selected by an internal pointer which is automatically incremented after each write access. This allows the use of efficient “move string” type commands by the microcontroller.

Depending on EXMD2.XFBS up to 16 or 32 bytes of transmit data can be written to the XFIFOD following an ISTAD.XPR interrupt.

4.1.3 ISTAD - Interrupt Status Register D-Channel

Value after reset: 10_H

	7							0	
ISTAD	RME	RPF	RFO	XPR	XMR	XDU	0	0	RD (20)

RME ... Receive Message End

One complete frame of length less than or equal to the defined block size (EXMD1.RFBS) or the last part of a frame of length greater than the defined block size has been received. The contents are available in the RFIFOD. The message length and additional information may be obtained from RBCHD and RBCLD and the RSTAD register.

RPF ... Receive Pool Full

A data block of a frame longer than the defined block size (EXMD1.RFBS) has been received and is available in the RFIFOD. The frame is not yet complete.

RFO ... Receive Frame Overflow

The received data of a frame could not be stored, because the RFIFOD is occupied. The whole message is lost.

This interrupt can be used for statistical purposes and indicates that the microcontroller does not respond quickly enough to an RPF or RME interrupt (ISTAD).

XPR ... Transmit Pool Ready

A data block of up to the defined block size 16 or 32 (EXMD1.XFBS) can be written to the XFIFOD.

An XPR interrupt will be generated in the following cases:

- after an XTF or XME command as soon as the 16 or 32 bytes in the XFIFO are available and the frame is not yet complete
- after an XTF together with an XME command is issued, when the whole frame has been transmitted
- after a reset of the transmitter (XRES)
- after a device reset

XMR ... Transmit Message Repeat

The transmission of the last frame has to be repeated because a collision on the S bus has been detected after the 16th/32nd data byte of a transmit frame.

Detailed Register Description

If an XMR interrupt occurs the transmit FIFO is locked until the XMR interrupt is read by the host (interrupt cannot be read if masked in MASKD).

XDU ... Transmit Data Underrun

The current transmission of a frame is aborted by transmitting seven '1's because the XFIFOD holds no further data. This interrupt occurs whenever the microcontroller has failed to respond to an XPR interrupt (ISTAD register) quickly enough, after having initiated a transmission and the message to be transmitted is not yet complete.

If an XDU interrupt occurs the transmit FIFO is locked until the XDU interrupt is read by the host (interrupt cannot be read if masked in MASKD).

4.1.4 MASKD - Mask Register D-Channel

Value after reset: FF_H

	7							0	
MASKD	RME	RPF	RFO	XPR	XMR	XDU	1	1	WR (20)

Each interrupt source in the ISTAD register can selectively be masked by setting the corresponding bit in MASKD to '1'. Masked interrupt status bits are not indicated when ISTAD is read. Instead, they remain internally stored and pending until the mask bit is reset to '0'.

4.1.5 STARD - Status Register D-Channel

Value after reset: 40_H

	7							0	
STARD	XDOV	XFW	0	0	RACI	0	XACI	0	RD (21)

XDOV ... Transmit Data Overflow

More than 16 or 32 bytes (according to selected block size) have been written to the XFIFOD, i.e. data has been overwritten.

XFW ... Transmit FIFO Write Enable

Data can be written to the XFIFOD. This bit may be polled instead of (or in addition to) using the XPR interrupt.

RACI ... Receiver Active Indication

The D-channel HDLC receiver is active when RACI = '1'. This bit may be polled. The RACI bit is set active after a begin flag has been received and is reset after receiving an abort sequence.

XACI ... Transmitter Active Indication

The D-channel HDLC-transmitter is active when XACI = '1'. This bit may be polled. The XACI-bit is active when an XTF-command is issued and the frame has not been completely transmitted

4.1.6 CMDRD - Command Register D-Channel

Value after reset: 00_H

	7							0	
CMDRD	RMC	RRES	0	STI	XTF	0	XME	XRES	WR (21)

RMC ... Receive Message Complete

Reaction to RPF (Receive Pool Full) or RME (Receive Message End) interrupt. By setting this bit, the microcontroller confirms that it has fetched the data, and indicates that the corresponding space in the RFIFOD may be released.

RRES ... Receiver Reset

HDLC receiver is reset, the RFIFOD is cleared of any data.

STI ... Start Timer 1

The ISAC-SX timer 1 is started when STI is set to one. The timer is stopped by writing to the TIMR1 register.

Note: Timer 2 is controlled by the TIMR2 register only.

XTF ... Transmit Transparent Frame

After having written up to 16 or 32 bytes (EXMD1.XFBS) to the XFIFOD, the microcontroller initiates the transmission of a transparent frame by setting this bit to '1'. The opening flag is automatically added to the message by the ISAC-SX (except in the extended transparent mode where no flags are used).

XME ... Transmit Message End

By setting this bit to '1' the microcontroller indicates that the data block written last to the XFIFOD completes the corresponding frame. The ISAC-SX terminates the transmission by appending the CRC (if EXMD1.XCRC=0) and the closing flag sequence to the data (except in the extended transparent mode where no such framing is used).

XRES ... Transmitter Reset

The D-channel HDLC transmitter is reset and the XFIFOD is cleared of any data. This command can be used by the microcontroller to abort a frame currently in transmission.

Note: After an XPR interrupt further data has to be written to the XFIFOD and the appropriate Transmit Command (XTF) has to be written to the CMDRD register again to continue transmission, when the current frame is not yet complete (see also XPR in ISTAD).

During frame transmission, the 0-bit insertion according to the HDLC bit-stuffing mechanism is done automatically.

4.1.7 MODED - Mode Register

Value after reset: C0_H

	7							0	
MODED	MDS2	MDS1	MDS0	0	RAC	DIM2	DIM1	DIM0	RD/WR (22)

Detailed Register Description

MDS2-0 ... Mode Select

Determines the message transfer mode of the HDLC controller, as follows:

MDS2-0	Mode	Number of Address Bytes	Address Comparison		Remark
			1.Byte	2.Byte	
0 0 0	Reserved				
0 0 1	Reserved				
0 1 0	Non-Auto mode	1	TEI1,TEI2	–	One-byte address compare.
0 1 1	Non-Auto mode	2	SAP1,SAP2,SAPG	TEI1,TEI2,TEIG	Two-byte address compare.
1 0 0	Extended transparent mode				
1 1 0	Transparent mode 0	–	–	–	No address compare. All frames accepted.
1 1 1	Transparent mode 1	> 1	SAP1,SAP2,SAPG	–	High-byte address compare.
1 0 1	Transparent mode 2	> 1	–	TEI1,TEI2,TEIG	Low-byte address compare.

Note: SAP1, SAP2: two programmable address values for the first received address byte (in the case of an address field longer than 1 byte);

SAPG = fixed value FC / FE_H.

TEI1, TEI2: two programmable address values for the second (or the only, in the case of a one-byte address) received address byte; TEIG = fixed value FF_H

Two different methods of the high byte and/or low byte address comparison can be selected by setting SAP1.MHA and/or SAP2.MLA.

Detailed Register Description

RAC ... Receiver Active

The D-channel HDLC receiver is activated when this bit is set to '1'. If set to '0' the HDLC data is not evaluated in the receiver.

DIM2-0 ... Digital Interface Modes

These bits define the characteristics of the IOM Data Ports (DU, DD). The DIM0 bit enables/disables the collision detection. The DIM1 bit enables/disables the TIC bus access. The effect of the individual DIM bits is summarized in the table below.

DIM2	DIM1	DIM0	Characteristics
0		0	Transparent D-channel, the collision detection is disabled
0		1	Stop/go bit evaluated for D-channel access handling
0	0		Last octet of IOM channel 2 used for TIC bus access
0	1		TIC bus access is disabled
1	x	x	Reserved

4.1.8 EXMD1- Extended Mode Register D-Channel 1

Value after reset: 00_H

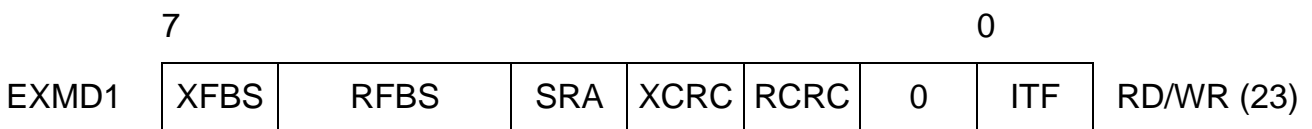

XFBS ... Transmit FIFO Block Size

0 ... Block size for the transmit FIFO data is 32 byte

1 ... Block size for the transmit FIFO data is 16 byte

Note: A change of XFBS will take effect after a receiver command (CMDRD.XME, CMDRD.XRES, CMDRD.XTF) has been written.

Detailed Register Description

RFBS ... Receive FIFO Block Size

RFBS		Block Size Receive FIFO
Bit 6	Bit5	
0	0	32 byte
0	1	16 byte
1	0	8 byte
1	1	4 byte

Note: A change of RFBS will take effect after a transmitter command (CMDR.RMC, CMDR.RRES,) has been written

SRA ... Store Receive Address

- 0 ... Receive Address isn't stored in the RFIFOD
- 1 ... Receive Address is stored in the RFIFOD

XCRC ... Transmit CRC

- 0 ... CRC is transmitted
- 1 ... CRC isn't transmitted

RCRC... Receive CRC

- 0 ... CRC isn't stored in the RFIFOD
- 1 ... CRC is stored in the RFIFOD

ITF... Interframe Time Fill

Selects the inter-frame time fill signal which is transmitted between HDLC-frames.

- 0 ... idle (continuous '1')
- 1 ... flags (sequence of patterns: '0111 1110')

Note: ITF must be set to '0' for power down mode.

In applications with D-channel access handling (collision resolution), the only possible inter-frame time fill is idle (continuous '1'). Otherwise the D-channel on the S/T-bus cannot be accessed

4.1.9 TIMR1 - Timer 1 Register

Value after reset: 00_H

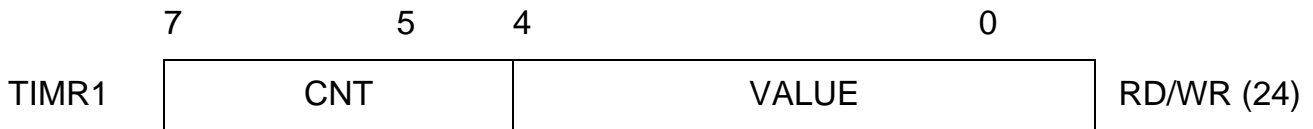

CNT ... Timer Counter

CNT together with VALUE determines the time period T after which a AUXI.TIN1 interrupt will be generated:

CNT=0...6: $T = CNT \times 2.048 \text{ sec} + T1$ with $T1 = (VALUE+1) \times 0.064 \text{ sec}$

CNT=7: $T = T1 = (VALUE+1) \times 0.064 \text{ sec}$ (generated periodically)

The timer can be started by setting the STI-bit in CMDRD and will be stopped when a TIN1 interrupt is generated or the TIMR1 register is written.

Note: If CNT is set to 7, a TIN interrupt is indefinitely generated after every expiration of T1 (i.e. $T = T1$).

VALUE ... Timer Value

Determines the value of the timer value $T1 = (VALUE + 1) \times 0.064 \text{ sec}$.

4.1.10 SAP1 - SAPI1 Register

Value after reset: FC_H

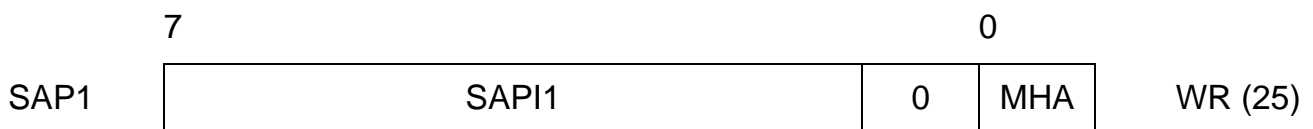

SAPI1 ... SAPI1 value

Value of the first programmable Service Access Point Identifier (SAPI) according to the ISDN LAPD protocol.

MHA... Mask High Address

0 ... The SAPI address of an incoming frame is compared with SAP1, SAP2, SAPG.

1 ... The SAPI address of an incoming frame is compared with SAP1 and SAPG.
SAP1 can be masked with SAP2 thereby bit positions of SAP1 are not compared if they are set to '1' in SAP2.

4.1.11 SAP2 - SAPI2 Register

Value after reset: FC_H

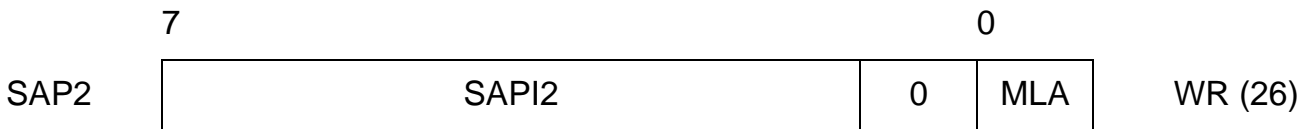

SAPI2 ... SAPI2 value

Value of the second programmable Service Access Point Identifier (SAPI) according to the ISDN LAPD-protocol.

MLA... Mask Low Address

0 ...The TEI address of an incoming frame is compared with TEI1, TEI2 and TEIG.

1 ...The TEI address of an incoming frame is compared with TEI1 and TEIG.

TEI1 can be masked with TEI2 thereby bit positions of TEI1 are not compared if they are set to '1' in TEI2.

4.1.12 RBCLD - Receive Frame Byte Count Low D-Channel

Value after reset: 00_H

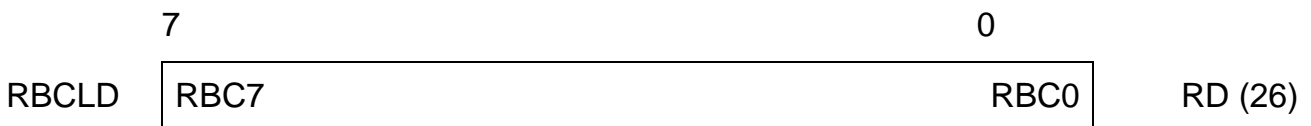

RBC7-0 ... Receive Byte Count

Eight least significant bits of the total number of bytes in a received message (see RBCHD register).

4.1.13 RBCHD - Receive Frame Byte Count High D-Channel

Value after reset: 00_H.

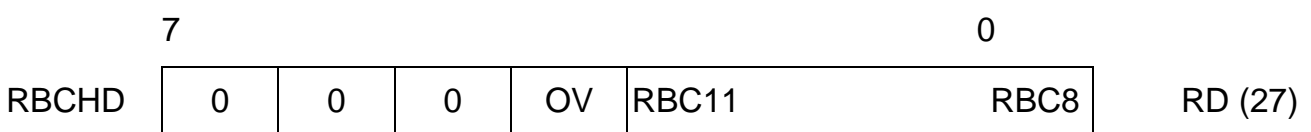

OV ... Overflow

A '1' in this bit position indicates a message longer than $(2^{12} - 1) = 4095$ bytes .

Detailed Register Description

RBC8-11 ... Receive Byte Count

Four most significant bits of the total number of bytes in a received message (see RBCLD register).

Note: Normally RBCHD and RBCLD should be read by the microcontroller after an RME-interrupt in order to determine the number of bytes to be read from the RFIFOD, and the total message length. The contents of the registers are valid only after an RME or RPF interrupt, and remain so until the frame is acknowledged via the RMC bit or RRES.

4.1.14 TEI1 - TEI1 Register 1

Value after reset: FF_H

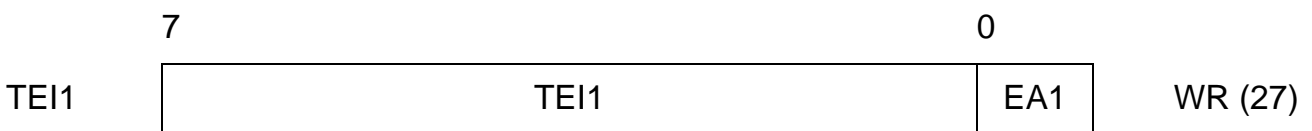

TEI1 ... Terminal Endpoint Identifier

In all message transfer modes except in transparent modes 0, 1 and extended transparent mode, TEI1 is used by the ISAC-SX for address recognition. In the case of a two-byte address field, it contains the value of the first programmable Terminal Endpoint Identifier according to the ISDN LAPD-protocol.

In non-automodes with one-byte address field, TEI1 is a command address, according to X.25 LAPB.

EA1 ... Address field Extension bit

This bit is set to '1' according to HDLC/LAPD.

4.1.15 TEI2 - TEI2 Register

Value after reset: FF_H

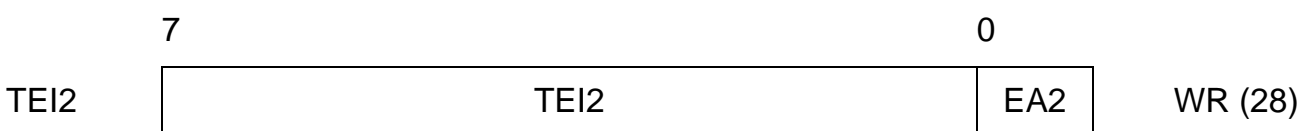

TEI2 ... Terminal Endpoint Identifier

In all message transfer modes except in transparent modes 0, 1 and extended transparent mode, TEI2 is used by the ISAC-SX for address recognition. In the case of

Detailed Register Description

a two-byte address field, it contains the value of the second programmable Terminal Endpoint Identifier according of the ISDN LAPD-protocol.

In non-auto-modes with one-byte address field, TEI2 is a response address, according to X.25 LAPD.

EA2 ... Address field Extension bit

This bit is to be set to '1' according to HDLC/LAPD.

4.1.16 RSTAD - Receive Status Register D-Channel

Value after reset: 0F_H

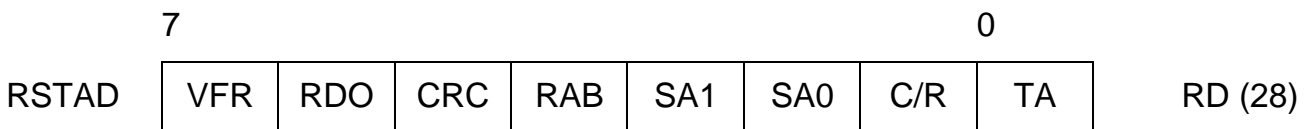

For general information please refer to [Figure](#) .

VFR... Valid Frame

Determines whether a valid frame has been received.

The frame is valid (1) or invalid (0).

A frame is invalid when there is not a multiple of 8 bits between flag and frame end (flag, abort).

RDO ... Receive Data Overflow

If RDO=1, at least one byte of the frame has been lost, because it could not be stored in RFIFOD. As opposed to the ISTAD.RFO an RDO indicates that the beginning of a frame has been received but not all bytes could be stored as the RFIFOD was temporarily full.

CRC ... CRC Check

The CRC is correct (1) or incorrect (0).

RAB ... Receive Message Aborted

The receive message was aborted by the remote station (1), i.e. a sequence of seven 1's was detected before a closing flag.

Detailed Register Description

SA1-0 ... SAPI Address Identification

TA ... TEI Address Identification

SA1-0 are significant in non-automode with a two-byte address field, as well as in transparent mode 3. TA is significant in all modes except in transparent modes 0 and 1.

Two programmable SAPI values (SAP1, SAP2) plus a fixed group SAPI (SAPG of value FC_H/FE_H), and two programmable TEI values (TEI1, TEI2) plus a fixed group TEI (TEIG of value FF_H), are available for address comparison.

The result of the address comparison is given by SA1-0 and TA, as follows:

MDS2-0	SA1	SA0	TA	Address Match with	
				1 st Byte	2 nd Byte
010 (Non-Auto/8 Mode)	x	x	0	TEI2	-
	x	x	1	TEI1	-
011 (Non-Auto/16 Mode)	0	0	0	SAP2	TEIG
	0	0	1	SAP2	TEI2
	0	1	0	SAPG	TEIG
	0	1	1	SAPG	TEI1 or TEI2
	1	0	0	SAP1	TEIG
111 (Transparent Mode1)	1	0	1	SAP1	TEI1
	0	0	x	SAP2	-
	0	1	x	SAPG	-
101 (Transparent Mode 2)	1	0	x	SAP1	-
	-	-	0	-	TEIG
	-	-	1	-	TEI1 or TEI2
	1	1	x	reserved	

Note: If SAP1 and SAP2 contain identical values, the combination SAP1,2-TEIG will only be indicated by SA1,0 = '10' (i.e. the value '00' will not occur in this case).

C/R ... Command/Response

The C/R bit contains the C/R bit of the received frame (Bit1 in the SAPI address)

Note: The contents of RSTAD corresponds to the last received HDLC frame; it is duplicated into RFIFOD for every frame (last byte of frame)

4.1.17 TMD -Test Mode Register D-Channel

Value after reset: 00_H

	7							0	
TMD	0	0	0	0	0	0	0	TLP	RD/WR (29)

For general information please refer to [Chapter 3.9](#).

TLP ... Test Loop

The TX path of layer-2 is internally connected with the RX path of layer-2. Data coming from the layer 1 controller will not be forwarded to the layer 2 controller.

The setting of TLP is only valid if the IOM interface is active.

4.1.18 CIR0 - Command/Indication Receive 0

Value after reset: F3_H

	7					0		
CIR0	CODR0			CIC0	CIC1	S/G	BAS	RD (2E)

CODR0 ... C/I Code 0 Receive

Value of the received Command/Indication code. A C/I-code is loaded in CODR0 only after being the same in two consecutive IOM-frames and the previous code has been read from CIR0.

CIC0 ... C/I Code 0 Change

A change in the received Command/Indication code has been recognized. This bit is set only when a new code is detected in two consecutive IOM-frames. It is reset by a read of CIR0.

CIC1 ... C/I Code 1 Change

A change in the received Command/Indication code in IOM-channel 1 has been recognized. This bit is set when a new code is detected in one IOM-frame. It is reset by a read of CIR0.

S/G ... Stop/Go Bit Monitoring

Indicates the availability of the upstream D-channel on the S/T interface.

- 1: Stop
- 0: Go

BAS ... Bus Access Status

Indicates the state of the TIC-bus:

- 0: the ISAC-SX itself occupies the D- and C/I-channel
- 1: another device occupies the D- and C/I-channel

Note: The CODR0 bits are updated every time a new C/I-code is detected in two consecutive IOM-frames. If several consecutive valid new codes are detected and CIR0 is not read, only the first and the last C/I code is made available in CIR0 at the first and second read of that register, respectively.

4.1.19 CIX0 - Command/Indication Transmit 0

Value after reset: FE_H

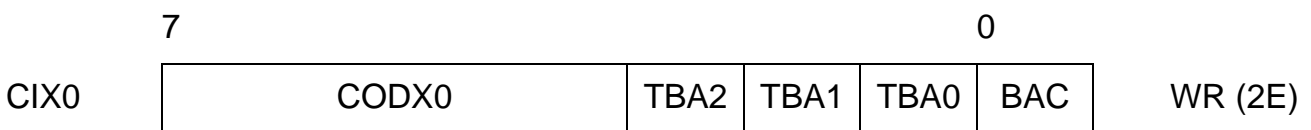

CODX0 ... C/I-Code 0 Transmit

Code to be transmitted in the C/I-channel 0.

The code is only transmitted if the TIC bus is occupied. If TIC bus is enabled but occupied by another device, only “1s” are transmitted.

TBA2-0 ... TIC Bus Address

Defines the individual address for the ISAC-SX on the IOM bus.

This address is used to access the C/I- and D-channel on the IOM interface.

Note: If only one device is liable to transmit in the C/I- and D-channels of the IOM it should always be given the address value '7'.

BAC ... Bus Access Control

Only valid if the TIC-bus feature is enabled (MODED.DIM2-0).

If this bit is set, the ISAC-SX will try to access the TIC-bus to occupy the C/I-channel even if no D-channel frame has to be transmitted. It should be reset when the access has been completed to grant a similar access to other devices transmitting in that IOM-channel.

Detailed Register Description

Note: Access is always granted by default to the ISAC-SX with TIC-Bus Address (TBA2-0, STCR register) '7', which has the lowest priority in a bus configuration.

4.1.20 CIR1 - Command/Indication Receive 1

Value after reset: FE_H

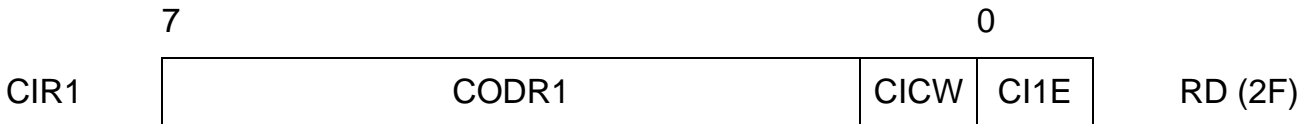

CODR1 ... C/I-Code 1 Receive

CICW, CI1E ... C/I-Channel Width, C/I-Channel 1 Interrupt Enable

These two bits contain the read back values from CIX1 register (see below).

4.1.21 CIX1 - Command/Indication Transmit 1

Value after reset: FE_H

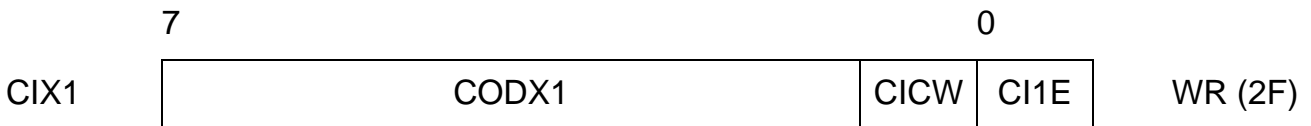

CODX1 ... C/I-Code 1 Transmit

Bits 7-2 of C/I-channel 1.

CICW... C/I-Channel Width

CICW selects between a 4 bit ('0') and 6 bit ('1') C/I1 channel width.

The C/I1 handler always reads and writes 6-bit values but if 4-bit is selected, the higher two bits are ignored for interrupt generation. However in write direction the full CODX1 code is transmitted, i.e. the host must write the higher two bits to "1".

CI1E ... C/I-Channel 1 Interrupt Enable

Interrupt generation ISTA.CIC of CIR0.CIC1 is enabled (1) or masked (0).

4.2 Transceiver Registers

4.2.1 TR_CONF0 - Transceiver Configuration Register 0

Value after reset: 01_H

	7						0		
TR_CONF0	DIS_TR	BUS	EN_ICV	0	L1SW	0	EXLP	LDD	RD/WR (30)

DIS_TR ... Disable Transceiver

Setting DIS_TR to “1” disables the transceiver. In order to reenale the transceiver again, a transceiver reset must be issued (SRES.RES_TR = 1). The transceiver must not be reenaled by setting DIS_TR from “1” to “0”.

For general information please refer to [Chapter 3.3.10](#).

BUS ... Point-to-Point / Bus Selection (NT, LT-S and Int. NT mode only)

0: Adaptive Timing (Point-t-Point, extended passive bus).

1: Fixed Timing (Short passive bus).

EN_ICV ... Enable Illegal Code Violation

0:normal operation

1:ICV enabled. The receipt of at least one illegal code violation within one multi-frame is indicated by the C/I indication '1011' (CVR) in two consecutive IOM frames.

L1SW ... Enable Layer 1 State Machine in Software

0:Layer 1 state machine of the ISAC-SX is used

1:Layer 1 state machine is disabled. The functionality can be realized in software. The commands can be written to register TR_CMD and the status can be read from TR_STA.

For general information please refer to [Chapter 3.5](#).

EXLP ... External loop

In case the analog loopback is activated with C/I = ARL or with the LP_A bit in the TR_CMD register the loop is a

0: internal loop next to the line pins

1: external loop which has to be closed between SR1/2 and SX1/SX2

Note: The external loop is only useful if bit DIS_TX of register TR_CONF2 is set to '0'.

Detailed Register Description

For general information please refer to [Chapter 3.3.11](#).

LDD ... Level Detection Discard

0: Automatic clock generation after detection of any signal on the line in power down state

1: No clock generation after detection of any signal on the line in power down state

Note: If an interrupt by the level detect circuitry is generated, the microcontroller has to set this bit to '0' for an activation of the S/T interface.

For general information please refer to [Chapter 3.3.9](#) and [Chapter 3.7.6](#).

4.2.2 TR_CONF1 - Transceiver Configuration Register 1

Value after reset: 0x_H

	7							0	
TR_CONF1	0	RPLL_ADJ	EN_SFSC	0	0	x	x	x	RD/WR (31)

RPLL_ADJ ... Receive PLL Adjustment

0: DPLL tracking step is 0.5 XTAL period per S-frame

1: DPLL tracking step is 1 XTAL period per S-frame

EN_SFSC ... Enable Short FSC

0: No short FSC is generated

1: A short FSC is generated once per multi-frame (every 40th IOM frame)

x ... Undefined

The value of these bits depends on the selected mode. It is important to note that these bits must not be overwritten to a different value when accessing this register.

4.2.3 TR_CONF2 - Transmitter Configuration Register 2

Value after reset: 80_H

	7							0	
TR_CONF2	DIS_TX	PDS	0	RLP	0	0	SGP	SGD	RD/WR (32)

DIS_TX ... Disable Line Driver

0: Transmitter is enabled

1: Transmitter is disabled

For general information please refer to [Chapter 3.3.10](#).

PDS ... Phase Deviation Select

Defines the phase deviation of the S-transmitter.

0: The phase deviation is 2 S-bits minus 7 oscillator periods plus analog delay plus delay of the external circuitry.

1: The phase deviation is 2 S-bits minus 9 oscillator periods plus analog delay plus delay of the external circuitry.

For general information please refer to [Chapter 3.3.8](#).

RLP ... Remote Line Loop

0: Remote Loop open

1: Remote Loop closed

For general information please refer to [Chapter 3.3.11](#).

SGP ... Stop/Go Bit Polarity

Defines the polarity of the S/G bit output on pin SGO.

0: low active (SGO=0 means "go"; SGO=1 means "stop")

1: high active (SGO=1 means "go"; SGO=0 means "stop")

SGD ... Stop/Go Bit Duration

Defines the duration of the S/G bit output on pin SGO.

0: active during the D-channel timeslot

1: active during the whole corresponding IOM frame (starts and ends with the beginning of the D-channel timeslot)

Note: Outside the active window of SGO (defined in SGD) the level on pin SGO remains in the "stop"-state depending on the selected polarity (SGP), i.e. SGO=1 (if SGP=0) or SGO=0 (if SGP=1) outside the active window.

4.2.4 TR_STA - Transceiver Status Register

Value after reset: 00_H

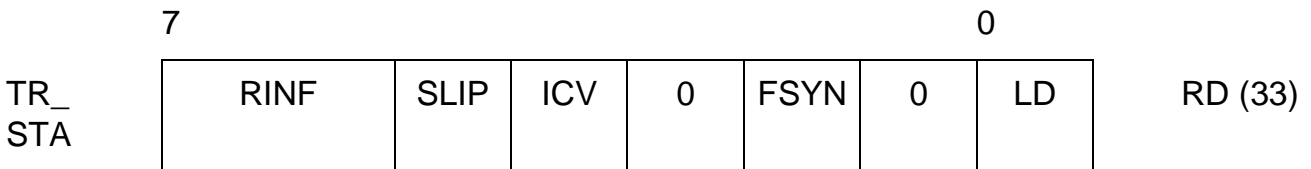

Important: This register is used only if the Layer 1 state machine of the ISAC-SX is disabled (TR_CONF0.L1SW = 1) and implemented in software! With the IPAC layer 1 state machine enabled, the signals from this register are automatically evaluated.

For general information please refer to [Chapter 3.5](#).

RINF ... Receiver INFO

00: Received INFO 0

01: Received any signal except INFO 0,2,3,4

10: Reserved (NT mode) or INFO 2 (TE mode)

11: Received INFO 3 (NT mode) or INFO 4 (TE mode)

SLIP ... SLIP Detected

A '1' in this bit position indicates that a SLIP is detected in the receive or transmit path.

ICV ... Illegal Code Violation

0: No illegal code violation is detected

1: Illegal code violation (ANSI T1.605) in data stream is detected

FSYN ... Frame Synchronization State

0: The S/T receiver is not synchronized

1: The S/T receiver has synchronized to the framing bit F

LD ... Level Detection

0: No receive signal has been detected on the line.

1: Any receive signal has been detected on the line.

4.2.5 TR_CMD - Transceiver Command Register

Value after reset: 08_H

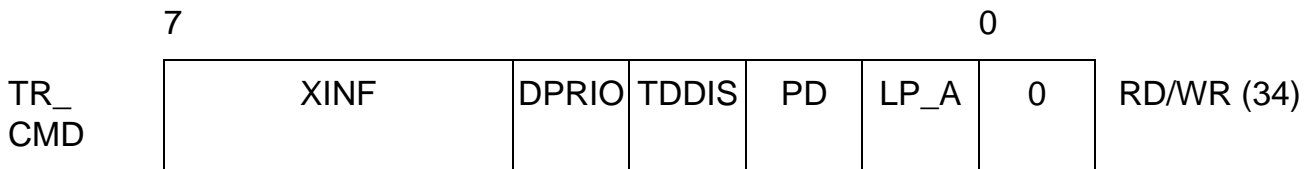

Important: This register is only writable if the Layer 1 state machine of the ISAC-SX is disabled (TR_CONF0.L1SW = 1)! With the ISAC-SX layer 1 state machine enabled, the signals from this register are automatically generated, but nevertheless this register can always be read. DPRIO can also be written in Intelligent NT mode.

XINF ... Transmit INFO

000: Transmit INFO 0

001: reserved

010: Transmit INFO 1 (TE mode) or INFO 2 (NT mode)

011: Transmit INFO 3 (TE mode) or INFO 4 (NT mode)

100: Send continuous pulses at 192 kbit/s alternating or 96 kHz rectangular, respectively (SCP)

101: Send single pulses at 4 kbit/s with alternating polarity corresponding to 2 kHz fundamental mode (SSP)

11x: reserved

DPRIO ... D-Channel Priority (always writable in Int. NT mode)

0: Priority Class 1 for D channel access on IOM (Int. NT) or on S interface (TE/LT-T)

1: Priority Class 2 for D channel access on IOM (Int. NT) or on S interface (TE/LT-T)

TDDIS ... Transmit Data Disabled (TE mode)

0: The B and D channel data are transparently transmitted on the S/T interface if INFO 3 is being transmitted

1: The B and D channel data are set to logical '1' on the S/T interface if INFO 3 is being transmitted

PD ... Power Down

0: The transceiver is set to operational mode

1: The transceiver is set to power down mode

For general information please refer to [Chapter 3.5.1.2](#).

LP_A ... Loop Analog

The setting of this bit corresponds to the C/I command ARL.

0: Analog loop is open

1: Analog loop is closed internally or externally according to the EXLP bit in the TR_CONF0 register

For general information please refer to [Chapter 3.3.11](#).

4.2.6 SQRR1 - S/Q-Channel Receive Register 1

Value after reset: 40_H

	7						0		
SQRR	MSYN	MFEN	0	0	SQR1	SQR2	SQR3	SQR4	RD (35)

For general information please refer to [Chapter 3.3.2](#).

MSYN ... Multi-frame Synchronization State

0: The S/T receiver has not synchronized to the received F_A and M bits

1: The S/T receiver has synchronized to the received F_A and M bits

MFEN ... Multiframe Enable

Read-back of the MFEN bit of the SQXR register

SQR11-14 ... Received S Bits

Received S bits in frames 1, 6, 11 and 16 (TE mode)

received Q bits in frames 1, 6, 11 and 16 (NT mode).

4.2.7 SQXR1- S/Q-Channel TX Register 1

Value after reset: 4F_H

	7								0	
SQXR1	0	MFEN	0	0	SQX1	SQX2	SQX3	SQX4	WR (35)	

MFEN ... Multiframe Enable

Used to enable or disable the multiframe structure (see [Chapter 3.3.2](#))

0: S/T multiframe is disabled

1: S/T multiframe is enabled

Readback value in SQRR1.

SQX1-4 ... Transmitted S/Q Bits

Transmitted Q bits (F_A bit position) in frames 1, 6, 11 and 16 (TE mode),
transmitted S bits (F_A bit position) in frames 1, 6, 11 and 16 (NT mode).

4.2.8 SQRR2 - S/Q-Channel Receive Register 2

Value after reset: 00_H

	7								0	
SQRR2	SQR21	SQR22	SQR23	SQR24	SQR31	SQR32	SQR33	SQR34	RD (36)	

SQR21-24, SQR31-34... Received S Bits (TE mode only)

Received S bits in frames 2, 7, 12 and 17 (SQR21-24, subchannel 2),
and in frames 3, 8, 13 and 18 (SQR31-34, subchannel 3).

4.2.9 SQXR2 - S/Q-Channel TX Register 2

Value after reset: 00_H

	7								0	
SQXR2	SQX21	SQX22	SQX23	SQX24	SQX31	SQX32	SQX33	SQX34	WR (36)	

SQX21-24, SQX31-34... Transmitted S Bits (NT mode only)

Transmitted S bits in frames 2, 7, 12 and 17 (SQX21-24, subchannel 2), and in frames 3, 8, 13 and 18 (SQX31-34, subchannel 3).

4.2.10 SQRR3 - S/Q-Channel Receive Register 3

Value after reset: 00_H

	7								0	
SQRR3		SQR41	SQR42	SQR43	SQR44	SQR51	SQR52	SQR53	SQR54	RD (37)

SQR41-44, SQR51-54... Received S Bits (TE mode only)

Received S bits in frames 4, 9, 14 and 19 (SQR41-44, subchannel 4), and in frames 5, 10, 15 and 20 (SQR51-54, subchannel 5).

4.2.11 SQXR3 - S/Q-Channel TX Register 3

Value after reset: 00_H

	7								0	
SQXR3		SQX41	SQX42	SQX43	SQX44	SQX51	SQX52	SQX53	SQX54	WR (37)

SQX41-44, SQX51-54... Transmitted S Bits (NT mode only)

Transmitted S bits in frames 4, 9, 14 and 19 (SQX41-44, subchannel 4), and in frames 5, 10, 15 and 20 (SQX51-54, subchannel 5).

4.2.12 ISTATR - Interrupt Status Register Transceiver

Value after reset: 00_H

	7								0	
ISTATR		x	x	x	x	LD	RIC	SQC	SQW	RD (38)

For all interrupts in the ISTATR register the following logical states are defined:

- 0: Interrupt is not acitvated
- 1: Interrupt is acitvated

x ... Reserved

Bits set to “1” in this bit position must be ignored.

LD ... Level Detection

Any receive signal has been detected on the line. This bit is set to “1” (i.e. an interrupt is generated if not masked) as long as any receiver signal is detected on the line.

RIC ... Receiver INFO Change

RIC is activated if one of the TR_STA bits RINF or ICV has changed. This bit is reset by reading the register TR_STA.

SQC ... S/Q-Channel Change

A change in the received S-channel (TE) or Q-channel (NT) has been detected. The new code can be read from the SQRxx bits of registers SQRR1-3 within the next multiframe (5 ms). This bit is reset by a read access to the corresponding SQRRx register.

SQW ... S/Q-Channel Writable

The S/Q channel data for the next multiframe is writable. The register for the Q (S) bits to be transmitted (received) has to be written (read) within the next multiframes (5 ms). This bit is reset by writing register SQXRx.

4.2.13 MASKTR - Mask Transceiver Interrupt

Value after reset: FF_H

7		0	
MASKTR	1	1	1
	1	LD	RIC
	SQC	SQW	RD/WR (39)

The transceiver interrupts LD, RIC, SQC and SQW are enabled (0) or disabled (1).

4.2.14 TR_MODE - Transceiver Mode Register 1

Value after reset: 000000xx_B

7		0	
TR_	0	0	0
MODE	0	DCH_	MODE
	MODE	2	1
	INH	0	RD/WR (3A)

For general information please refer also to [Chapter 3.7.5.4](#).

DCH_INH ... D-Channel Inhibit

Setting this bit to '1' has the effect that the S-transceiver blocks the access to the D-channel on S by inverting the E-bits.

MODE2-0 ... Transceiver Mode

- 000: TE mode
- 001: LT-T mode
- 010: NT mode (without D-channel handler)
- 011: LT-S mode (without D-channel handler)
- 110: Intelligent NT mode (with NT state machine and with D-channel handler)
- 111: Intelligent NT mode (with LT-S state machine and with D-channel handler)
- 100: reserved
- 101: reserved

Note: The three modes TE, LT-T and LT-S can be selected by pin strapping (reset values for bits TR_MODE.MODE0,1 loaded from pins MODE0,1), all other modes are programmable only.

4.3 Auxiliary Interface Registers

4.3.1 ACFG1 - Auxiliary Configuration Register 1

Value after reset: 00_H

	7							0	
ACFG1	OD7	OD6	OD5	OD4	OD3	OD2	OD1	OD0	RD/WR (3C)

For general information please refer to [Chapter 3.8.1](#).

OD7-0 ... Output Driver Select for AUX7 - AUX0

0: output is open drain

1: output is push/pull

Note: The ODx configuration is only valid if the corresponding output is enabled in the AOE register.

AUX0-2 are only available in TE and Int. NT mode and not in all other modes (used as channel select).

AUX7 and AUX6 provide internal pull up resistors which are only available as inputs and in output/open drain mode, but disabled in output / push/pull mode.

4.3.2 ACFG2 - Auxiliary Configuration Register 2

Value after reset: 00_H

	7						0		
ACFG2	A7SEL	A5SEL	FBS	A4SEL	ACL	LED	EL1	EL0	RD/WR (3D)

A7SEL ... AUX7 Function Select

0: pin AUX7 provides normal I/O functionality.

1: pin AUX7 provides the S/G bit output (SGO) from the IOM DD-line. Bit AOE.OE7 is don't care, the output characteristic (push pull or open drain) can be selected via ACFG1.OD7.

A5SEL ... AUX5 Function Select

0: pin AUX5 provides normal I/O functionality.

1: pin AUX5 provides an FSC or BCL signal output (FBOUT) which is selected in ACFG2.FBS. Bit AOE.OE5 is don't care, the output characteristic (push pull or open drain) can be selected via ACFG1.OD5.

For general information please refer to [Chapter 3.4](#).

FBS ... FSC/BCL Output Select

0: FSC is output on pin AUX5.

1: BCL (single bit clock) is output on pin AUX5.

Note: This selection has only effect on pin AUX5 if FBOUT is enabled (A5SEL=1).

In LT-T mode pin SCLK provides an 1.536 MHz output clock which can be used as DCL input. This is necessary for BCL generation.

For general information please refer to [Chapter 3.4](#).

A4SEL ... AUX4 Function Select

0: pin AUX4 provides normal I/O functionality.

1: pin AUX4 supports multiframe synchronization and is used as M-bit input in Int. NT/NT/LT-S modes or as M-bit output in TE/LT-T modes (input/output is automatically selected with the mode). Bit AOE.OE4 is don't care, the output characteristic (push pull or open drain) can be selected via ACFG1.OD4.

For general information please refer to [Chapter 3.3.3](#).

ACL ... ACL Function Select

0: Pin \overline{ACL} automatically indicates the S-bus activation status by a LOW level.

1: The output state of \overline{ACL} is programmable by the host in bit LED.

Note: An LED with preresistance may directly be connected to \overline{ACL} .

LED ... LED Control

If enabled (ACL=1) the LED with preresistance connected between VDD and \overline{ACL} is switched ...

0: Off (high level on pin \overline{ACL})

1: On (low level on pin \overline{ACL})

EL0, 1 ... Edge/Level Triggered Interrupt Input for $\overline{INT0}$, $\overline{INT1}$

0: A negative level ...

1: A negative edge ... on $\overline{INT0/1}$ (pins AUX6/7) generates an interrupt to the ISAC-SX.

Detailed Register Description

Note: An interrupt is only generated if the corresponding mask bit in AUXM is reset. This configuration is only valid if the corresponding output enable bit in AOE is disabled.

For general information please refer to [Chapter 3.8.1](#).

4.3.3 AOE - Auxiliary Output Enable Register

Value after reset: FF_H

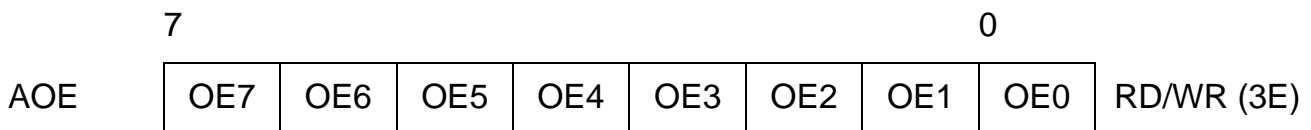

For general information please refer to [Chapter 3.8.1](#).

OE7-0 ... Output Enable for AUX7 - AUX0

0: Pin AUX7-0 is configured as output. The value of the corresponding bit in the ATX register is driven on AUX7-0.

1: Pin AUX7-0 is configured as input. The value of the corresponding bit can be read from the ARX register.

Note: In NT and LT modes the pins AUX0-2 are not available as I/O pins. If pins AUX7, AUX6 are to be used as interrupt input, OE7, OE6 must be set to 1. If pins AUX7, AUX5 and AUX4 are not used as I/O pins (see ACFG2), the corresponding OEx bit cannot be set, but delivers the mode dependent direction (input/output) in that function upon a read access. If the secondary function is disabled, the direction of the pin as I/O pin is valid again.

4.3.4 ARX - Auxiliary Interface Receive Register

Value after reset: (not defined)

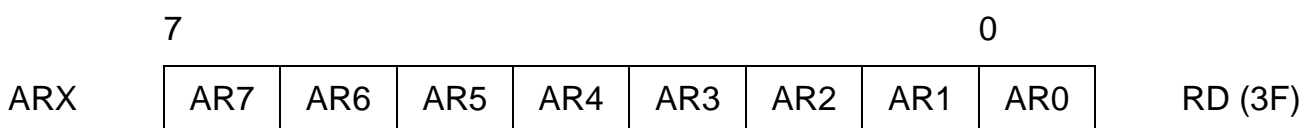

AR7-0 ... Auxiliary Receive

The value of AR7-0 always reflects the level at pin AUX7-0 at the time when ARX is read by the host even if a pin is configured as output. If the mask bit for AUX7, 6 is set in the MASKA register, no interrupt is generated to the ISAC-SX, however, the current state at pin AUX7,6 can be read from AR7,6

Detailed Register Description

Note: In NT and LT modes the pins AUX0-2 are not available as I/O pins.

4.3.5 ATX - Auxiliary Interface Transmit Register

Value after reset: 00_H

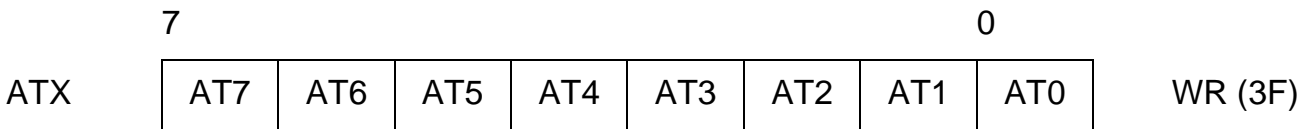

AT7-0 ... Auxiliary Transmit

A '0' or '1' in AT7-0 will drive a low or a high level at pin AUX7-0 if the corresponding output is enabled in the AOE register.

Note: In NT and LT modes the pins AUX0-2 are not available as I/O pins.

4.4 IOM-2 and MONITOR Handler

4.4.1 CDAXy - Controller Data Access Register xy



Data registers CDAXy which can be accessed from the controller.

Register	Register Address	Value after Reset
CDA10	40 _H	FF _H
CDA11	41 _H	FF _H
CDA20	42 _H	FF _H
CDA21	43 _H	FF _H

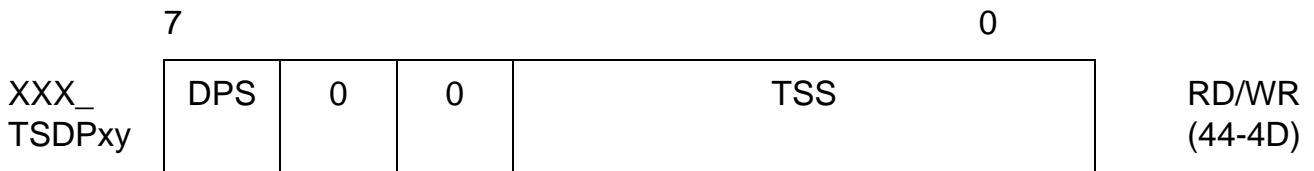
Detailed Register Description
4.4.2 XXX_TSDPxy - Time Slot and Data Port Selection for CHxy

Register	Register Address	Value after Reset
CDA_TSDP10	44 _H	00 _H (= output on B1-DD)
CDA_TSDP11	45 _H	01 _H (= output on B2-DD)
CDA_TSDP20	46 _H	80 _H (= output on B1-DU)
CDA_TSDP21	47 _H	81 _H (= output on B2-DU)
BCH_TSDP_BC1	48 _H	80 _H (= output on B1-DU)
BCH_TSDP_BC2	49 _H	81 _H (= output on B2-DU)
TR_TSDP_BC1	4C _H	00 _H (= transceiver output on B1-DD), see note
TR_TSDP_BC2	4D _H	01 _H (= transceiver output on B2-DD), see note

This register determines the time slots and the data ports on the IOM-2 interface for the data channels 'xy' of the functional units 'XXX' which are Controller Data Access (CDA), B-channel controller (BCH) and Transceiver (TR).

The B-channel controller (BCH) can access any combination of two 8-bit timeslots and one 2-bit timeslot (e.g. 16-bit access to B1+B2 or 18-bit IDSL in 2B+D). The position of the two 8-bit timeslots is programmed in BCH_TSDP_BC1 and BCH_TSDP_BC2. The position of the 2-bit timeslot is programmed in BCH_CR. In the same registers each of the three timeslots is enabled/disabled.

The position of B-channel data from the S-interface is programmed in TR_TSDP_BC1 and TR_TSDP_BC2.

Note: The reset values for TR_TSDP_BC1/2 are depending on the mode selection (MODE0/1) and channel selection (CH0-2).

DPS ... Data Port Selection

0: The data channel xy of the functional unit XXX is output on DD.
The data channel xy of the functional unit XXX is input from DU.
1: The data channel xy of the functional unit XXX is output on DU.
The data channel xy of the functional unit XXX is input from DD.

Note: For the CDA (controller data access) data the input is determined by the CDA_CRx.SWAP bit. If SWAP = '0' the input for the CDAxy data is vice versa to the output setting for CDAxy. If the SWAP = '1' the input from CDAx0 is vice versa to the output setting of CDAx1 and the input from CDAx1 is vice versa to the output setting of CDAx0. See controller data access description in [Chapter 3.7.1.1](#).

TSS ... Timeslot Selection

Selects one of 32 timeslots (0...31) on the IOM-2 interface for the data channels.

Note: The TSS reset values for TR_TSDP_BC1/2 are determined by the channel select pins CH2-0 which are mapped to the corresponding bits TSS4-2.

4.4.3 CDAx_CR - Control Register Controller Data Access CH1x

	7						0		
CDAx_CR	0	0	EN_TBM	EN_I1	EN_I0	EN_O1	EN_O0	SWAP	RD/WR (4E-4F)

Register	Register Address	Value after Reset
CDA1_CR	4E _H	00 _H
CDA2_CR	4F _H	00 _H

For general information please refer to [Chapter 3.7.1.1](#).

EN_TBM ... Enable TIC Bus Monitoring

0: The TIC bus monitoring is disabled
1: The TIC bus monitoring with the CDAx0 register is enabled. The TSDPx0 register must be set to 08_H for monitoring from DU or 88_H for monitoring from DD, respectively (This selection is only valid if IOM_CR.TIC_DIS = 0).

EN_I1, EN_I0 ... Enable Input CDAX0, CDAX1

- 0: The input of the CDAX0, CDAX1 register is disabled
- 1: The input of the CDAX0, CDAX1 register is enabled

EN_O1, EN_O0 ... Enable Output CDAX0, CDAX1

- 0: The output of the CDAX0, CDAX1 register is disabled
- 1: The output of the CDAX0, CDAX1 register is enabled

SWAP ... Swap Inputs

- 0: The time slot and data port for the input of the CDAXy register is defined by its own TSDPxy register. The data port for the CDAXy input is vice versa to the output setting for CDAXy.
- 1: The input (time slot and data port) of the CDAX0 is defined by the TSDP register of CDAX1 and the input of CDAX1 is defined by the TSDP register of CDAX0. The data port for the CDAX0 input is vice versa to the output setting for CDAX1. The data port for the CDAX1 input is vice versa to the output setting for CDAX0. The input definition for time slot and data port CDAX0 are thus swapped to CDAX1 and for CDAX1 to CDAX0. The outputs are not affected by the SWAP bit.

4.4.4 TR_CR - Control Register Transceiver Data (IOM_CR.CI_CS=0)

Value after reset: F8_H

	7		0				
TR_CR	EN_D	EN_B2R	EN_B1R	EN_B2X	EN_B1X	CS2-0	RD/WR (50)

Read and write access to this register is only possible if IOM_CR.CI_CS = 0.

EN_D ... Enable Transceiver D-Channel Data

EN_B2R ... Enable Transceiver B2 Receive Data

EN_B1R ... Enable Transceiver B1 Receive Data

EN_B2X ... Enable Transceiver B2 Transmit Data

EN_B1X ... Enable Transceiver B1 Transmit Data

This register is used to individually enable/disable the D-channel (both RX and TX direction) and the receive/transmit paths for the B-channel of the S-transceiver.

- 0: The corresponding data path to the transceiver is disabled.
- 1: The corresponding data path to the transceiver is enabled.

Detailed Register Description

Note: Receive data corresponds to downstream direction, and transmit data corresponds to upstream direction.

CS2-0 ... Channel Select for Transceiver D-channel

This register is used to select one of eight IOM channels to which the transceiver D-channel data is related to.

Note: The reset value is determined by the channel select pins CH2-0 which are directly mapped to CS2-0. It should be noted that writing TR_CR.CS2-0 will also write to TRC_CR.CS2-0 and therefore modify the channel selection for the transceiver C/I/O data.

4.4.4.1 TRC_CR - Control Register Transceiver C/I/O (IOM_CR.CI_CS=1)

Value after reset: 00_H

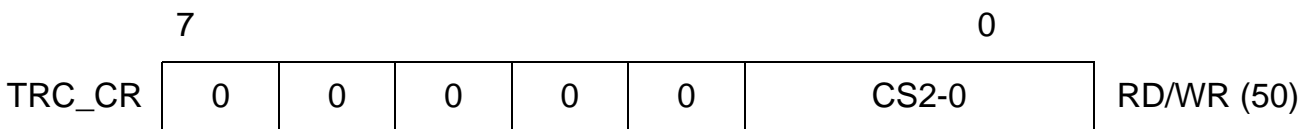

Write access to this register is possible if IOM_CR.CI_CS = 0 or IOM_CR.CI_CS = 1.
Read access to this register is possible only if IOM_CR.CI_CS = 1.

CS2-0 ... Channel Select for the Transceiver C/I/O Channel

This register is used to select one of eight IOM channels to which the transceiver C/I/O channel data is related to. The reset value is determined by the MODE2-bit and the channel select pins CH2-0 which are mapped to CS2-0.

4.4.5 BCH_CR - Control Register B-Channel Controller Data

Value after reset: 08_H

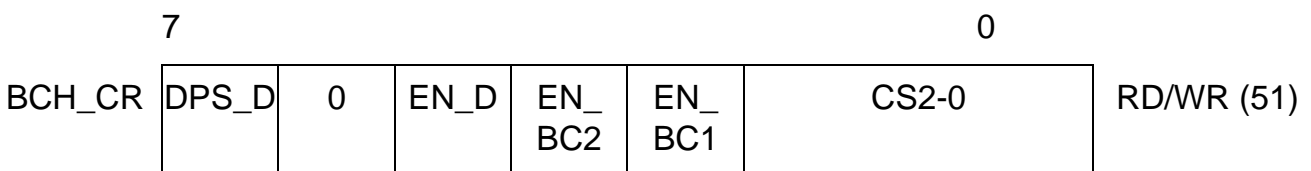

The registers BCH_TSDP_BC1/2 (see above) select the IOM-2 timeslots for B-channel controller access. For the B-channel controller two 8-bit timeslots can be selected (position and direction).

This register BCH_CR is used to select the position (CS2-0) and direction (DPS_D) of the 2-bit timeslot for the B-channel controller, and each of the three selected timeslots (2 x 8-bit and 2-bit) is individually enabled/disabled (EN_BC1, EN_BC2, EN_D).

DPS_D ... Data Port Selection for D-Channel Timeslot access

- 0: The B-channel controller data is output on DD.
The B-channel controller data is input from DU.
- 1: The B-channel controller data is output on DU.
The B-channel controller data is input from DD.

EN_D ... Enable D-Channel Timeslot (2-bit) for B-Channel controller access

EN_BC2 ... Enable B2-Channel Timeslot (8-bit) for B-Channel controller access

EN_BC1 ... Enable B1-Channel Timeslot (8-bit) for B-Channel controller access

These bits individually enable/disable the B-channel access to the 2-bit and the two 8-bit timeslots.

- 0: B-channel B/A does not access timeslot data B1, B2 or D, respectively.
- 1: B-channel B/A does access timeslot data B1, B2 or D, respectively.

Note: The terms B1/B2 should not imply that the 8-bit timeslots must be located in the first/second IOM-2 timeslots, it's simply a placeholder for the 8-bit timeslot position selected in the registers BCH_TSDP_BC1/2.

CS2-0 ... Channel Select for D-Channel Timeslot access

This register is used to select one of eight IOM channels. If enabled (EN_D=1), the B-channel controller is connected to the 2-bit D-channel timeslot of that IOM channel.

Note: The reset value is determined by the channel select pins CH2-0 which are directly mapped to CS2-0.

4.4.6 DCI_CR - Control Register for D and CI1 Handler (IOM_CR.CI_CS=0)

Value after reset: A0_H

	7					0		
DCI_CR	DPS_C11	EN_C11	D_EN_D	D_EN_B2	D_EN_B1	CS2-0		RD/WR (53)

Read and write access to this register is only possible if IOM_CR.CI_CS = 0.

DPS_CI1 ... Data Port Selection CI1 Handler Data

- 0: The CI1 handler data is output on DD and input from DU
- 1: The CI1 handler data is output on DU and input from DD

Detailed Register Description

EN_CI1 ... Enable CI1 Handler Data

0: CI1 handler data access is disabled

1: CI1 handler data access is enabled

Note: The timeslot for the C/I1 handler cannot be programmed but is fixed to IOM channel 1.

D_EN_D ... Enable D-timeslot for D-channel controller

D_EN_B2 ... Enable B2-timeslot for D-channel controller

D_EN_B1 ... Enable B1-timeslot for D-channel controller

These bits are used to select the timeslot length for the D-channel HDLC controller access as it is capable to access not only the D-channel timeslot. The host can individually enable two 8-bit timeslots B1- and B2-channel (D_EN_B1, D_EN_B2) and one 2-bit timeslot D-channel (D_EN_D) on IOM-2. The position is selected via CS2-0.

0: D-channel controller does not access timeslot data B1, B2 or D, respectively

1: D-channel controller does access timeslot data B1, B2 or D, respectively

CS2-0 ... Channel Select for D-channel controller

This register is used to select one of eight IOM channels. If enabled, the D-channel data is connected to the corresponding timeslots of that IOM channel.

Note: The reset value is determined by the channel select pins CH2-0 which are directly mapped to CS2-0. It should be noted that writing DCI_CR.CS2-0 will also write to DCIC_CR.CS2-0 and therefore modify the channel selection for the data of the C/I0 handler.

4.4.6.1 DCIC_CR - Control Register for CI0 Handler (IOM_CR.CI_CS=1)

Value after reset: 00_H

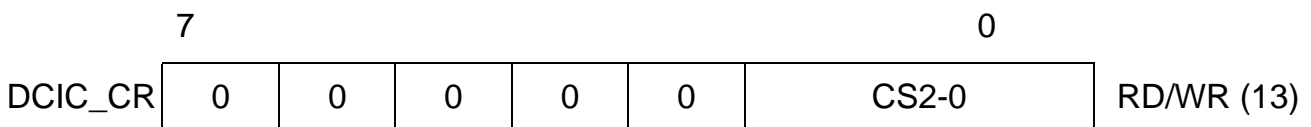

Write access to this register is possible if IOM_CR.CI_CS = 0 or IOM_CR.CI_CS = 1.

Read access to this register is possible only if IOM_CR.CI_CS = 1.

CS2-0 ... Channel Select for C/I0 Handler

This register is used to select one of eight IOM channels. If enabled, the data of the C/I0 handler is connected to the corresponding C/I0 timeslot of that IOM channel. The reset value is determined by the channel select pins CH2-0 which are mapped to CS2-0.

4.4.7 MON_CR - Control Register Monitor Data

Value after reset: 40_H

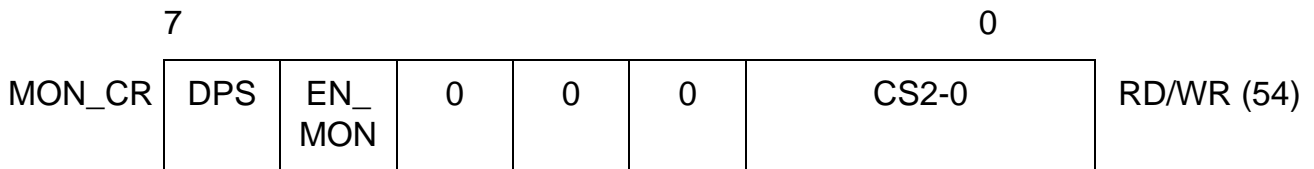

For general information please refer to [Chapter 3.7.3](#).

DPS ... Data Port Selection

0: The Monitor data is output on DD and input from DU

1: The Monitor data is output on DU and input from DD

EN_MON ... Enable Output

0: The Monitor data input and output is disabled

1: The Monitor data input and output is enabled

CS2-0 ... MONITOR Channel Selection

000: The MONITOR data is input/output on MON0 (3rd timeslot on IOM-2)

001: The MONITOR data is input/output on MON1 (7th timeslot on IOM-2)

010: The MONITOR data is input/output on MON2 (11th timeslot on IOM-2)

:

111: The MONITOR data is input/output on MON7 (31st timeslot on IOM-2)

Note: The reset value is determined by the channel select pins CH2-0 which are directly mapped to CS2-0.

4.4.8 SDSx_CR - Control Register Serial Data Strobe x

Value after reset: 00_H

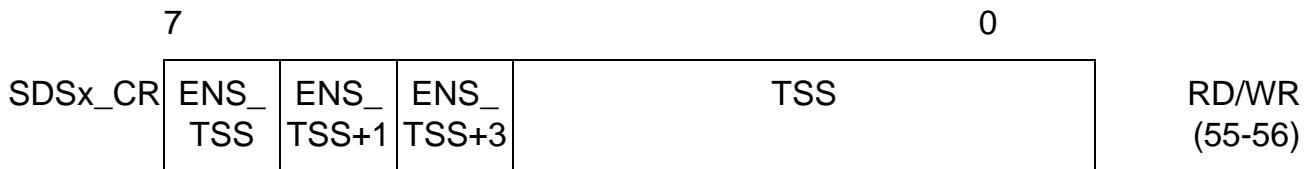

Register	Register Address	Value after Reset
SDS1_CR	55 _H	00 _H
SDS2_CR	56 _H	00 _H

This register is used to select position and length of the strobe signals. The length can be any combination of two 8-bit timeslot (ENS_TSS, ENS_TSS+1) and one 2-bit timeslot (ENS_TSS+3).

For general information please refer to [Chapter 3.7.2](#) and [Chapter 3.7.2.2](#).

ENS_TSS ... Enable Serial Data Strobe of timeslot TSS

ENS_TSS+1 ... Enable Serial Data Strobe of timeslot TSS+1

0: The serial data strobe signal SDSx is inactive during TSS, TSS+1

1: The serial data strobe signal SDSx is active during TSS, TSS+1

ENS_TSS+3 ... Enable Serial Data Strobe of timeslot TSS+3 (D-Channel)

0: The serial data strobe signal SDSx is inactive during the D-channel (bit7, 6) of TSS+3

1: The serial data strobe signal SDSx is active during the D-channel (bit7, 6) of TSS+3

TSS ... Timeslot Selection

Selects one of 32 timeslots on the IOM-2 interface (with respect to FSC) during which SDSx is active high or provides a strobed BCL clock output (see SDS_CONF.SDS1/2_BCL). The data strobe signal allows standard data devices to access a programmable channel.

4.4.9 IOM_CR - Control Register IOM Data

Value after reset: 08_H

	7							0	
IOM_CR	SPU	DIS_ AW	CI_CS	TIC_ DIS	EN_ BCL	CLKM	DIS_ OD	DIS_ IOM	RD/WR (57)

SPU ... Software Power Up

0: The DU line is normally used for transmitting data

1: Setting this bit to '1' will pull the DU line to low. This will enforce connected layer 1 devices to deliver IOM-clocking.

After a subsequent ISTA.CIC-interrupt (C/I-code change) and reception of the C/I-code "PU" (Power Up indication in TE-mode) the microcontroller writes an AR or TIM command as C/I-code in the CIX0-register, resets the SPU bit and waits for the following CIC-interrupt.

For general information please refer to [Chapter 3.7.6](#).

DIS_AW ... Disable Asynchronous Awake (NT, LT-S, Int. NT mode only)

Setting this bit to "1" disables the Asynchronous Awake function of the transceiver.

CI_CS ... C/I Channel Selection

The channel selection for D-channel and C/I-channel is done in the channel select bits CH2-0 of register TR_CR (for the transceiver) and DCI_CR (for the D-channel controller and C/I-channel controller).

0: A write access to CS2-0 has effect on the configuration of D- and C/I-channel, whereas a read access delivers the D-channel configuration only.

1: A write access to CS2-0 has effect on the configuration of the C/I-channel only, whereas a read access delivers the C/I-channel configuration only.

TIC_DIS ... TIC Bus Disable

0: The last octet of IOM channel 2 (12th timeslot) is used as TIC bus (in a frame timing with 12 timeslots only).

1: The TIC bus is disabled. The last octet of the last IOM time slot (TS 11) can be used as every time slot.

EN_BCL ... Enable Bit Clock BCL/SCLK

0: The BCL/SCLK clock is disabled

1: The BCL/SCLK clock is enabled.

CLKM ... Clock Mode

If the transceiver is disabled ($DIS_TR = '1'$) or in NT, LT-S and Int. NT mode the DCL from the IOM-2 interface is an input.

0: A double bit clock is connected to DCL

1: A single bit clock is connected to DCL

For general information please refer to [Chapter 3.7](#).

DIS_OD ... Disable Open Drain Drivers

0: DU/DD are open drain drivers

1: DU/DD are push pull drivers

DIS_IOM ... Disable IOM

DIS_IOM should be set to '1' if external devices connected to the IOM interface should be "disconnected" e.g. for power saving purposes or for not disturbing the internal IOM connection between layer 1 and layer 2. However, the ISAC-SX internal operation between S-transceiver, B-channel and D-channel controller is independent of the DIS_IOM bit.

0: The IOM interface is enabled

1: The IOM interface is disabled. The FSC, DCL clock outputs have high impedance; clock inputs are active; DU, DD data line inputs are switched off and outputs have high impedance; except in TE/LT-T mode the DU line is input ('0'-level causes activation), so the DU pin must be terminated (pull up resistor).

4.4.10 STI - Synchronous Transfer Interrupt

Value after reset: 00_H

	7						0		
STI	STOV 21	STOV 20	STOV 11	STOV 10	STI 21	STI 20	STI 11	STI 10	RD (58)

For all interrupts in the STI register the following logical states are applied:

0: Interrupt is not activated

1: Interrupt is activated

The interrupts are automatically reset by reading the STI register. For general information please refer to [Chapter 3.7.1.1](#).

STOVxy ... Synchronous Transfer Overflow Interrupt

Enabled STOV interrupts for a certain STI_{xy} interrupt are generated when the STI_{xy} has not been acknowledged in time via the ACK_{xy} bit in the ASTI register. This must be one (for DPS='0') or zero (for DPS='1') BCL clocks before the time slot which is selected for the STOV.

STI_{xy} ... Synchronous Transfer Interrupt

Depending on the DPS bit in the corresponding TSDP_{xy} register the Synchronous Transfer Interrupt STI_{xy} is generated two (for DPS='0') or one (for DPS='1') BCL clock after the selected time slot (TSDP_{xy}.TSS).

Note: STOV_{xy} and ACK_{xy} are useful for synchronizing microcontroller accesses and receive/transmit operations. One BCL clock is equivalent to two DCL clock cycles.

4.4.11 ASTI - Acknowledge Synchronous Transfer Interrupt

Value after reset: 00_H

	7							0	
ASTI	0	0	0	0	ACK 21	ACK 20	ACK 11	ACK 10	WR (58)

For general information please refer to [Chapter 3.7.1.1](#).

ACKxy ... Acknowledge Synchronous Transfer Interrupt

After an STI_{xy} interrupt the microcontroller has to acknowledge the interrupt by setting the corresponding ACK_{xy} bit to "1".

4.4.12 MSTI - Mask Synchronous Transfer Interrupt

Value after reset: FF_H

	7							0	
MSTI	STOV 21	STOV 20	STOV 11	STOV 10	STI 21	STI 20	STI 11	STI 10	RD/WR (59)

For the MSTI register the following logical states are applied:

0: Interrupt is not masked

1: Interrupt is masked

For general information please refer to [Chapter 3.7.1.1](#).

STOVxy ... Synchronous Transfer Overflow for STI_{xy}

Mask bits for the corresponding STOV_{xy} interrupt bits.

STI_{xy} ... Synchronous Transfer Interrupt xy

Mask bits for the corresponding STI_{xy} interrupt bits.

Detailed Register Description

4.4.13 SDS_CONF - Configuration Register for Serial Data Strobes

Value after reset: 00_H

	7						0		
SDS_CONF	0	0	0	0	DIOM_INV	DIOM_SDS	SDS2_BCL	SDS1_BCL	RD/WR (5A)

For general information on SDS1/2_BCL please refer to [Chapter 3.7.2](#).

DIOM_INV ... DU/DD on IOM Timeslot Inverted

0: DU/DD are active during SDS1 HIGH phase and inactive during the LOW phase.
 1: DU/DD are active during SDS1 LOW phase and inactive during the HIGH phase.
 This bit has only effect if DIOM_SDS is set to '1' otherwise DIOM_INV is don't care.

DIOM_SDS ... DU/DD on IOM Controlled via SDS1

0: The pin SDS1 and its configuration settings are used for serial data strobe only. The IOM-2 data lines are not affected.
 1: The DU/DD lines are deactivated during the during High/Low phase (selected via DIOM_INV) of the SDS1 signal. The SDS1 timeslot is selected in SDS1_CR.

SDSx_BCL ... Enable IOM Bit Clock for SDSx

0: The serial data strobe is generated in the programmed timeslot.
 1: The IOM bit clock is generated in the programmed timeslot.

4.4.14 MCDA - Monitoring CDA Bits

Value after reset: FF_H

	7						0		
MCDA	MCDA21		MCDA20		MCDA11		MCDA10		RD (5B)
	Bit7	Bit6	Bit7	Bit6	Bit7	Bit6	Bit7	Bit6	

MCDAxy ... Monitoring CDAxy Bits

Bit 7 and Bit 6 of the CDAxy registers are mapped into the MCDA register.
 This can be used for monitoring the D-channel bits on DU and DD and the 'Echo bits' on the TIC bus with the same register

Detailed Register Description

4.4.15 MOR - MONITOR Receive Channel

Value after reset: FF_H

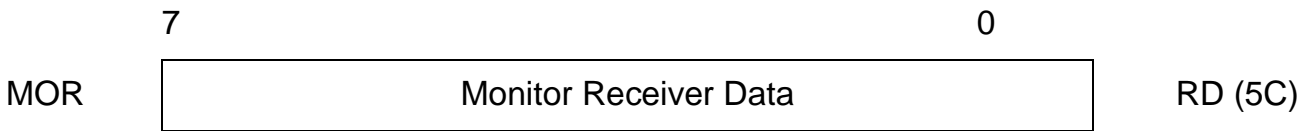

Contains the MONITOR data received in the IOM-2 MONITOR channel according to the MONITOR channel protocol. The MONITOR channel (0-7) can be selected by setting the monitor channel select bit MON_CR.MCS.

4.4.16 MOX - MONITOR Transmit Channel

Value after reset: FF_H

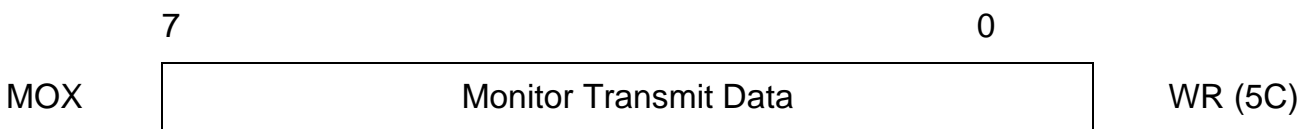

Contains the MONITOR data to be transmitted in IOM-2 MONITOR channel according to the MONITOR channel protocol. The MONITOR channel (0-7) can be selected by setting the monitor channel select bit MON_CR.MCS

4.4.17 MOSR - MONITOR Interrupt Status Register

Value after reset: 00_H

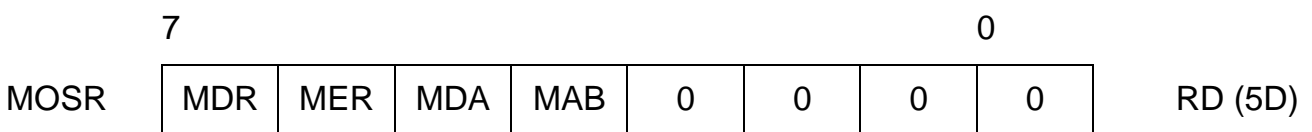

MDR ... MONITOR channel Data Received

MER ... MONITOR channel End of Reception

MDA ... MONITOR channel Data Acknowledged

The remote end has acknowledged the MONITOR byte being transmitted.

MAB ... MONITOR channel Data Abort

4.4.18 MOCR - MONITOR Control Register

Value after reset: 00_H

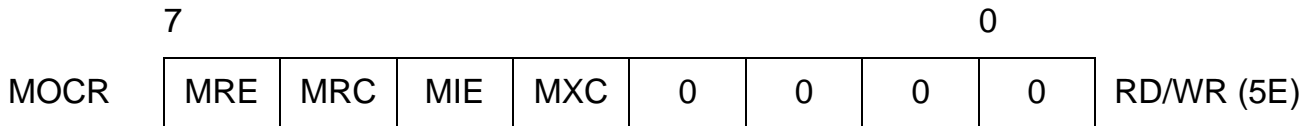

MRE ... MONITOR Receive Interrupt Enable

- 0: MONITOR interrupt status MDR generation is masked
- 1: MONITOR interrupt status MDR generation is enabled

MRC ... MR Bit Control

Determines the value of the MR bit:

- 0: MR is always '1'. In addition, the MDR interrupt is blocked, except for the first byte of a packet (if MRE = 1).
- 1: MR is internally controlled by the ISAC-SX according to MONITOR channel protocol. In addition, the MDR interrupt is enabled for all received bytes according to the MONITOR channel protocol (if MRE = 1).

MIE ... MONITOR Interrupt Enable

MONITOR interrupt status MER, MDA, MAB generation is enabled (1) or masked (0).

MXC ... MX Bit Control

Determines the value of the MX bit:

- 0: The MX bit is always '1'.
- 1: The MX bit is internally controlled by the ISAC-SX according to MONITOR channel protocol.

4.4.19 MSTA - MONITOR Status Register

Value after reset: 00_H

MSTA	0	0	0	0	0	MAC	0	TOUT	RD (5F)
------	---	---	---	---	---	-----	---	------	---------

MAC ... MONITOR Transmit Channel Active

The data transmission in the MONITOR channel is in progress.

TOUT ... Time-Out

Read-back value of the TOUT bit.

4.4.20 MCONF - MONITOR Configuration Register

Value after reset: 00_H

MCONF	0	0	0	0	0	0	0	TOUT	WR (5F)
-------	---	---	---	---	---	---	---	------	---------

TOUT... Time-Out

0: The monitor time-out function is disabled

1: The monitor time-out function is enabled

4.5 Interrupt and General Configuration

4.5.1 ISTA - Interrupt Status Register

Value after reset: 00_H

	7							0	
ISTA	ICB	0	ST	CIC	AUX	TRAN	MOS	ICD	RD (60)

For all interrupts in the ISTA register following logical states are applied:

0: Interrupt is not activated

1: Interrupt is activated

ICB, ICD ... HDLC Interrupt from B-channel or D-channel

An interrupt originated from the HDLC controllers of the B-channel or D-channel has been recognized.

ST ... Synchronous Transfer

This interrupt is generated to enable the microcontroller to lock on to the IOM timing for synchronous transfers. The source can be read from the STI register.

CIC ... C/I Channel Change

A change in C/I channel 0 or C/I channel 1 has been recognized. The actual value can be read from CIR0 or CIR1.

AUX ... Auxiliary Interrupts

Signals an interrupt generated from external awake (pin \overline{EAW}), watchdog timer overflow, timer1, timer2 or from one of the interrupt input pins ($\overline{INT0}$, $\overline{INT1}$). The source can be read from the auxiliary interrupt register AUXI.

TRAN ... Transceiver Interrupt

An interrupt originated in the transceiver interrupt status register (ISTATR) has been recognized.

MOS ... MONITOR Status

A change in the MONITOR Status Register (MOSR) has occurred.

Note: A read of the ISTA register clears none of the interrupts. They are only cleared by reading the corresponding status register.

4.5.2 MASK - Mask Register

Value after reset: FF_H

	7								0	
MASK	ICB	1	ST	CIC	AUX	TRAN	MOS	ICD	WR (60)	

For the MASK register following logical states are applied:

- 0: Interrupt is enabled
- 1: Interrupt is disabled

Each interrupt source in the ISTA register can selectively be masked/disabled by setting the corresponding bit in MASK to '1'. Masked interrupt status bits are not indicated when ISTA is read. Instead, they remain internally stored and pending, until the mask bit is reset to '0'.

Note: In the event of a C/I channel change, CIC is set in ISTA even if the corresponding mask bit in MASK is set, but no interrupt is generated.

4.5.3 AUXI - Auxiliary Interrupt Status Register

Value after reset: 00_H

	7							0	
AUXI	0	0	EAW	WOV	TIN2	TIN1	INT1	INT0	RD (61)

For all interrupts in the ISTA register following logical states are applied:

- 0: Interrupt is not activated
- 1: Interrupt is activated

EAW ... External Awake Interrupt

An interrupt from the $\overline{\text{EAW}}$ pin has been detected.

WOV ... Watchdog Timer Overflow

Signals the expiration of the watchdog timer, which means that the microcontroller has failed to set the watchdog timer control bits WTC1 and WTC2 (MODE1 register) in the correct manner. A reset pulse has been generated by the ISAC-SX.

TIN2, 1 ... Timer Interrupt 1, 2

An interrupt originated from timer 1 or timer 2 is recognized, i.e the timer has expired.

Detailed Register Description

INT1, 0 ... Auxiliary Interrupt from external devices 1, 0

A low level or a negative state transition (programmable in ACFG2.EL1/0) is detected at pin AUX7 or AUX6, respectively.

4.5.4 AUXM - Auxiliary Mask Register

Value after reset: FF_H

	7							0	
AUXM	1	1	EAW	WOV	TIN2	TIN1	INT1	INT0	WR (61)

For the MASK register following logical states are applied:

- 0: Interrupt is enabled
- 1: Interrupt is disabled

Each interrupt source in the AUXI register can selectively be masked/disabled by setting the corresponding bit in AUXM to '1'. Masked interrupt status bits are not indicated when AUXI is read. Instead, they remain internally stored and pending, until the mask bit is reset to '0'.

4.5.5 MODE1 - Mode1 Register

Value after reset: 00_H

	7						0		
MODE1	0	0	0	WTC1	WTC2	CFS	RSS2	RSS1	RD/WR (62)

WTC1, 2 ... Watchdog Timer Control 1, 2

After the watchdog timer mode has been selected (RSS = '11') the watchdog timer is started. During every time period of 128 ms the microcontroller has to program the WTC1 and WTC2 bit in the following sequence

	WTC1	WTC2
1.	1	0
2.	0	1

to reset and restart the watchdog timer.

If WTC1/2 is not written fast enough in this way, the timer expires and a WOV-interrupt (AUXI register) together with a reset pulse is generated.

Detailed Register Description

CFS ... Configuration Select

This bit determines clock relations and recovery on S/T and IOM interfaces.

0: The IOM interface clock and frame signals are always active, "Power Down" state included.

The states "Power Down" and "Power Up" are thus functionally identical except for the indication: PD = 1111 and PU = 0111.

With the C/I command Timing (TIM) the microcontroller can enforce the "Power Up" state and with C/I command Deactivation Indication (DI) the "Power Down" state is reached again.

However, it is also possible to activate the S-interface directly with the C/I command Activate Request (AR 8/10/L) without the TIM command.

1: The IOM interface clock and frame signals are normally inactive ("Power Down").

For activating the IOM-2 clocks the "Power Up" state can be induced by software (IOM_CR.SPU) or by resetting CFS again.

After that the S-interface can be activated with the C/I command Activate Request (AR 8/10/L). The "Power Down" state can be reached again with the C/I command Deactivation Indication (DI).

Note: After reset the IOM interface is always active. To reach the "Power Down" state the CFS-bit has to be set.

For general information please refer to [Chapter 3.3.9](#).

RSS2, RSS1... Reset Source Selection 2,1

The ISAC-SX reset sources for the \overline{RSTO} output pin can be selected according to the table below.

RSS		C/I Code Change	EAW	Watchdog Timer
Bit 1	Bit 0			
0	0	--	--	--
0	1	(reserved)		
1	0	x	x	--
1	1	--	--	x

- If RSS = '00' no above listed reset source is selected and therefore no reset is generated at \overline{RSTO} .
- **Watchdog Timer**
After the selection of the watchdog timer (RSS = '11') the timer is reset and started. During every time period of 128 ms the microcontroller has to program the WTC1 and WTC2 bits in two consecutive bit pattern (see description of the WTC1, 2 bits)

Detailed Register Description

otherwise the watchdog timer expires and a reset pulse of $125 \mu\text{s} \leq t \leq 250 \mu\text{s}$ is generated. Deactivation of the watchdog timer is only possible with a hardware reset.

- If $\text{RSS} = '10'$ is selected the following two reset sources generate a reset pulse of $125 \mu\text{s} \leq t \leq 250 \mu\text{s}$ at the $\overline{\text{RSTO}}$ pin:

- External (Subscriber) Awake (EAW)

The **EAW** input pin serves as a request signal from the subscriber to initiate the awake function in a terminal and generates a reset pulse (in TE mode only).

- Exchange Awake (C/I Code)

A C/I Code change generates a reset pulse.

After a reset pulse generated by the ISAC-SX and the corresponding interrupt (WOV or CIC) the actual reset source can be read from the ISTA.

4.5.6 MODE2 - Mode2 Register

Value after reset: 00_H

	7							0	
MODE2	0	0	0	0	INT_ POL	0	0	PPSDX	RD/WR (63)

INT_POL ... Interrupt Polarity

Selects the polarity of the interrupt pin $\overline{\text{INT}}$.

0: low active with open drain characteristic (default)

1: high active with push pull characteristic

PPSDX ... Push/Pull Output for SDX (SCI Interface)

0: The SDX pin has open drain characteristic

1: The SDX pin has push/pull characteristic

4.5.7 ID - Identification Register

Value after reset: 01_H



DESIGN ... Design Number

The design number allows to identify different hardware designs of the ISAC-SX by software.

01_H: V 1.4

(all other codes reserved)

4.5.8 SRES - Software Reset Register

Value after reset: 00_H

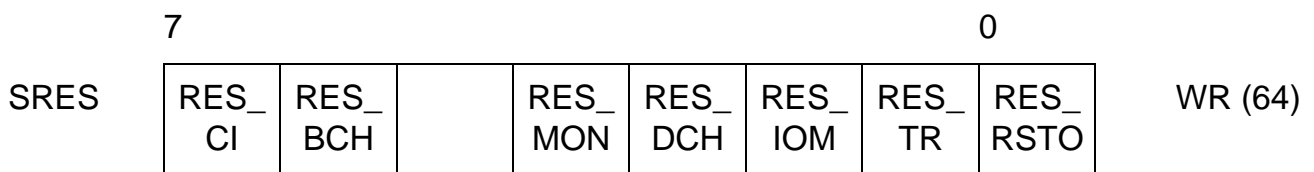

RES_xx ... Reset Functional Block xx

A reset can be activated on the functional block C/I-handler, B-channel, Monitor channel, D-channel, IOM handler, S-transceiver and to pin \overline{RSTO} .

Setting one of these bits to "1" causes the corresponding block to be reset for a duration of 4 BCL clock cycles, except RES_RSTO which is activated for a duration of 125 ... 250 μ s. The bits are automatically reset to "0" again.

4.5.9 TIMR2 - Timer 2 Register

Value after reset: 00_H

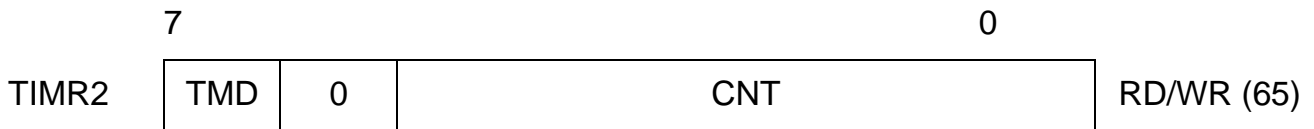

TMD ... Timer Mode

Timer 2 can be used in two different modes of operation.

0:Count Down Timer.

An interrupt is generated only once after a time period of 1 ... 63 ms.

1:Periodic Timer.

An interrupt is periodically generated every 1 ... 63 ms (see CNT).

CNT ... Timer Counter

0:Timer off.

1 ... 63:Timer period = 1 ... 63 ms

By writing '0' to CNT the timer is immediately stopped. A value different from that determines the time period after which an interrupt will be generated.

If the timer is already started with a certain CNT value and is written again before an interrupt has been released, the timer will be reset to the new value and restarted again. An interrupt is indicated to the host in AUXI.TIN2.

Note: Reading back this value delivers back the current counter value which may differ from the programmed value if the counter is running.

4.6 B-Channel Registers

4.6.1 ISTAB - Interrupt Status Register B-Channel

Value after reset: 10_H

	7							0	
ISTAB	RME	RPF	RFO	XPR	0	XDU	0	0	RD (70)

For general information please refer to [Chapter 3.8.7](#).

RME ... Receive Message End

One complete frame of length less than or equal to the defined block size (EXMB.RFBS) or the last part of a frame of length greater than the defined block size has been received. The contents are available in the RFIFOB. The message length and additional information may be obtained from RBCHB and RBCLB and the RSTAB register.

RPF ... Receive Pool Full

A data block of a frame longer than the defined block size (EXMB.RFBS) has been received and is available in the RFIFOB. The frame is not yet complete.

RFO ... Receive Frame Overflow

The received data of a frame could not be stored, because the RFIFOB is occupied. The whole message is lost.

This interrupt can be used for statistical purposes and indicates that the microcontroller does not respond quickly enough to an RPF or RME interrupt (ISTAB).

XPR ... Transmit Pool Ready

A data block of up to the block size 32 bytes can be written to the XFIFOB.

An XPR interrupt will be generated in the following cases:

- after an XTF or XME command as soon as the 32 bytes in the XFIFOB are available and the frame is not yet complete
- after an XTF together with an XME command is issued, when the whole frame has been transmitted
- after a reset of the transmitter (XRES)
- after a device reset

XDU ... Transmit Data Underrun

The current transmission of a frame is aborted by transmitting seven '1's because the XFIFOB holds no further data. This interrupt occurs whenever the microcontroller has failed to respond to an XPR interrupt (ISTAB register) quickly enough, after having initiated a transmission and the message to be transmitted is not yet complete.

4.6.2 MASKB - Mask Register B-Channel

Value after reset: FF_H

	7						0		
MASKB	RME	RPF	RFO	XPR	1	XDU	1	1	WR (70)

Each interrupt source in the ISTAB register can selectively be masked by setting the corresponding bit in MASKB to '1'. Masked interrupt status bits are not indicated when ISTAB is read. Instead, they remain internally stored and pending until the mask bit is reset to '0'.

For general information please refer to [Chapter 3.8.7](#).

4.6.3 STARB - Status Register B-Channel

Value after reset: 40_H

	7						0		
STARB	XDOV	XFW	0	0	RACI	0	XACI	0	RD (71)

XDOV ... Transmit Data Overflow

More than 32 bytes have been written to the XFIFOB, i.e. data has been overwritten.

XFW ... Transmit FIFO Write Enable

Data can be written to the XFIFOB. This bit may be polled instead of (or in addition to) using the XPR interrupt.

RACI ... Receiver Active Indication

The B-channel HDLC receiver is active when RACI = '1'. This bit may be polled. The RACI bit is set active after a begin flag has been received and is reset after receiving an abort sequence.

XACI ... Transmitter Active Indication

The B-channel HDLC-transmitter is active when XACI = '1'. This bit may be polled. The XACI-bit is active when an XTF-command is issued and the frame has not been completely transmitted

4.6.4 CMDRB - Command Register B-channel

Value after reset: 00_H

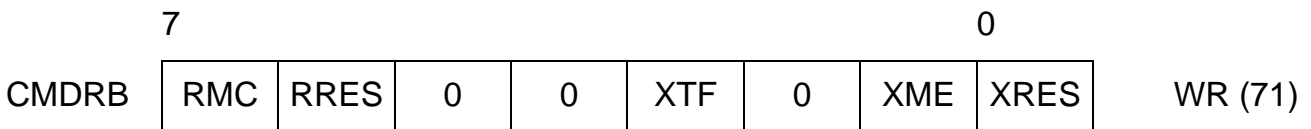

RMC ... Receive Message Complete

Reaction to RPF (Receive Pool Full) or RME (Receive Message End) interrupt. By setting this bit, the microcontroller confirms that it has fetched the data, and indicates that the corresponding space in the RFIFOB may be released.

RRES ... Receiver Reset

HDLC receiver is reset, the RFIFOB is cleared of any data.

XTF ... Transmit Transparent Frame

After having written up to 32 bytes to the XFIFOB, the microcontroller initiates the transmission of a transparent frame by setting this bit to '1'. The opening flag is automatically added to the message by the ISAC-SX.

XME ... Transmit Message End

By setting this bit to '1' the microcontroller indicates that the data block written last to the XFIFOB completes the corresponding frame. The ISAC-SX terminates the transmission by appending the CRC and the closing flag sequence to the data.

XRES ... Transmitter Reset

The B-channel HDLC transmitter is reset and the XFIFOB is cleared of any data. This command can be used by the microcontroller to abort a frame currently in transmission.

Note: After an XPR interrupt further data has to be written to the XFIFOB and the appropriate Transmit Command (XTF) has to be written to the CMDRB register again to continue transmission, when the current frame is not yet complete (see also XPR in ISTAB).

During frame transmission, the 0-bit insertion according to the HDLC bit-stuffing mechanism is done automatically.

Detailed Register Description

4.6.5 MODEB - Mode Register

Value after reset: C0_H

	7						0	
MODEB	MDS2	MDS1	MDS0	0	RAC	0	0	0
								RD/WR (72)

MDS2-0 ... Mode Select

Determines the message transfer mode of the HDLC controller, as follows:

MDS2-0	Mode	Number of Address Bytes	Address Comparison		Remark
			1.Byte	2.Byte	
0 0 0	Reserved				
0 0 1	Reserved				
0 1 0	Non-Auto mode	1	RAL1,RAL2	–	One-byte address compare.
0 1 1	Non-Auto mode	2	RAH1,RAH2, Group Address	RAL1,RAL2, Group Address	Two-byte address compare.
1 0 0	Extended transparent mode				
1 1 0	Transparent mode 0	–	–	–	No address compare. All frames accepted.
1 1 1	Transparent mode 1	> 1	RAH1,RAH2, Group Address	–	High-byte address compare.
1 0 1	Transparent mode 2	> 1	–	RAL1,RAL2, Group Address	Low-byte address compare.

Note: - RAH1, RAH2: two programmable address values for the first received address byte (in the case of an address field longer than 1 byte);
Group Address= fixed value FC / FE_H.
- RAL1, RAL2: two programmable address values for the second (or the only, in the case of a one-byte address) received address byte;
Group Address= fixed value FF_H.

RAC ... Receiver Active

The B-channel HDLC receiver is activated when this bit is set to '1'. If set to '0' the HDLC data is not evaluated in the receiver.

4.6.6 EXMB - Extended Mode Register B-Channel

Value after reset: C0_H

	7						0		
EXMB	1	1	RFBS	SRA	XCRC	RCRC	0	ITF	RD/WR (73)

RFBS ... Receive FIFO Block Size

0 ... Block size is 16 byte

1 ... Block size is 8 byte

*Note: A change of RFBS will take effect after a transmitter command (CMDRB.RMC, CMDRB.RRES,) has been written
The transmit FIFO block size is fixed to 32 byte and cannot be configured.*

SRA ... Store Receive Address

0 ... Receive Address is not stored in the RFIFOB

1 ... Receive Address is stored in the RFIFOB

XCRC ... Transmit CRC

0 ... CRC is transmitted

1 ... CRC is not transmitted

RCRC... Receive CRC

0 ... CRC is not stored in the RFIFOB

1 ... CRC is stored in the RFIFOB

ITF... Interframe Time Fill

Selects the inter-frame time fill signal which is transmitted between HDLC-frames.

0 ... idle (continuous '1')

1 ... flags (sequence of patterns: '0111 1110')

4.6.7 RAH1 - RAH1 Register

Value after reset: 00_H

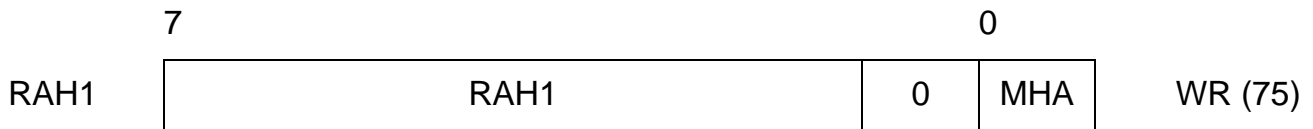

RAH1 ... Value of the first individual programmable high address byte

In operating modes that provide high byte address recognition, the high byte of the received address is compared with the individual programmable values in RAH1, RAH2 or group address FC_H/FE_H.

MHA ... Mask High Address

0: The RAH1 address of an incoming frame is compared with RAH1, RAH2 and Group Address.

1: The RAH1 address of an incoming frame is compared with RAH1 and Group Address. RAH1 can be masked with RAH2 thereby bitpositions of RAH1 are not compared if they are set to '1' in RAH2.

4.6.8 RAH2 - RAH2 Register

Value after reset: 00_H

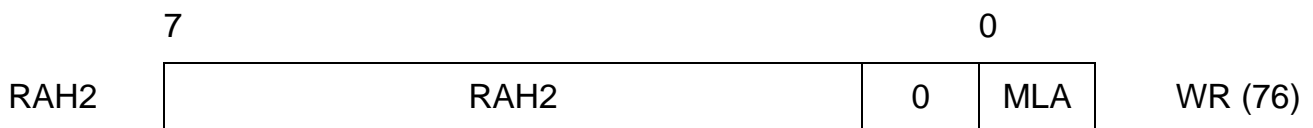

RAH2 ... Value of the second individual programmable high address byte

See RAH1 register above. RAH1 and RAH2 are used in non-auto mode when a 2-byte address field has been selected and in the transparent mode 1.

MLA ... Mask Low Address

0: The address of an incoming frame is compared with RAL1, RAL2 and Group Address.

1: The address of an incoming frame is compared with RAL1 and Group Address. RAL1 can be masked with RAL2 thereby bitpositions of RAL1 are not compared if they are set to '1' in RAL2.

4.6.9 RBCLB - Receive Frame Byte Count Low B-Channel

Value after reset: 00_H

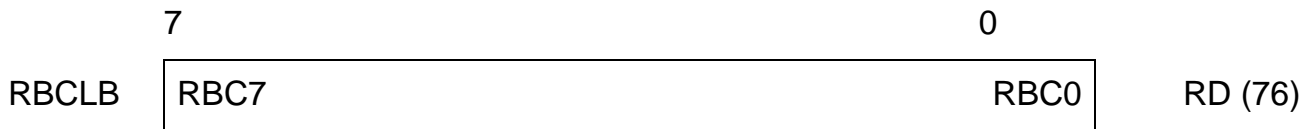

RBC7-0 ... Receive Byte Count

Eight least significant bits of the total number of bytes in a received message (see RBCHB register).

4.6.10 RBCHB - Receive Frame Byte Count High B-Channel

Value after reset: 00_H.

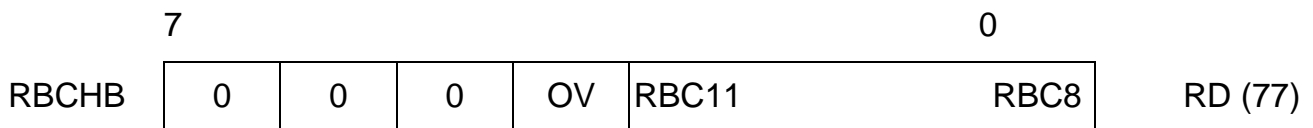

OV ... Overflow

A '1' in this bit position indicates a message longer than $(2^{12} - 1) = 4095$ bytes .

RBC8-11 ... Receive Byte Count

Four most significant bits of the total number of bytes in a received message (see RBCLB register).

Note: Normally RBCHB and RBCLB should be read by the microcontroller after an RME-interrupt in order to determine the number of bytes to be read from the RFIFOB, and the total message length. The contents of the registers are valid only after an RME or RPF interrupt, and remain so until the frame is acknowledged via the RMC bit or RRES.

4.6.11 RAL1 - RAL1 Register 1

Value after reset: 00_H

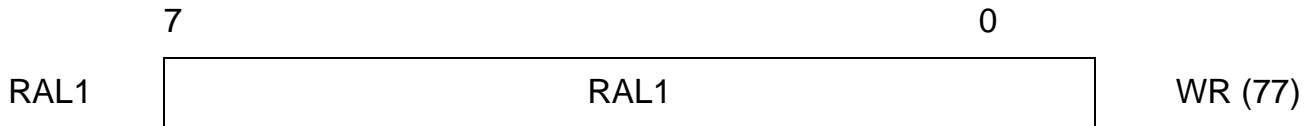

RAL1 ... Receive Address Byte Low Register 1

The general function (READ/WRITE) and the meaning or contents of this register depends on the selected operating mode:

- Non-auto mode (16-bit address):
RAL1 can be programmed with the value of the first individual low address byte.
- Non-auto mode (8-bit address):
According to X.25 LAPB protocol, the address in RAL1 is recognized as COMMAND address.

4.6.12 RAL2 - RAL2 Register

Value after reset: 00_H

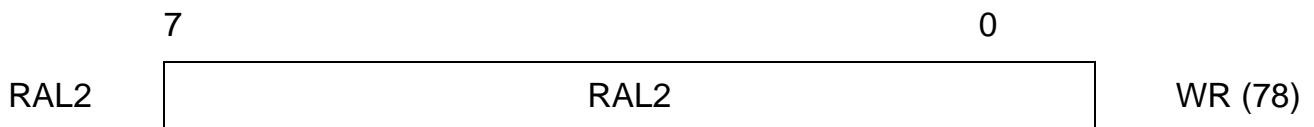

RAL2 ... Receive Address Byte Low Register 2

Value of the second individual programmable low address byte. If a one byte address field is selected, RAL2 is recognized as RESPONSE according to X.25 LAPB protocol.

4.6.13 RSTAB - Receive Status Register B-Channel

Value after reset: 0E_H

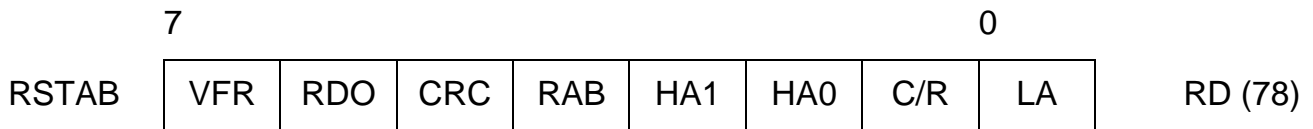

VFR... Valid Frame

Determines whether a valid frame has been received.

The frame is valid (1) or invalid (0).

A frame is invalid when there is not a multiple of 8 bits between flag and frame end (flag, abort).

RDO ... Receive Data Overflow

If RDO=1, at least one byte of the frame has been lost, because it could not be stored in RFIFOB. As opposed to ISTAB.RFO an RDO indicates that the beginning of a frame has been received but not all bytes could be stored as the RFIFOB was temporarily full.

CRC ... CRC Check

The CRC is correct (1) or incorrect (0).

RAB ... Receive Message Aborted

The receive message was aborted by the remote station (1), i.e. a sequence of seven 1's was detected before a closing flag.

HA1, HA0 ... High Byte Address Compare; significant only in non automode 16 and in transparent mode 1

In operating modes which provide high byte address recognition, the ISAC-SX compares the high byte of a 2-bytes address with the contents of two individual programmable registers (RAH1, RAH2) and the fixed values FE_H and FC_H (group address).

Depending on the result of this comparison, the following bit combinations are possible:

10 ... RAH1 has been recognized

00 ... RAH2 has been recognized

01 ... group address has been recognized

C/R ... Command/Response

The C/R bit contains the C/R bit of the received frame (Bit1 in the SAPI address, LAPD)

Detailed Register Description

LA ... Low Byte Address Compare; significant only in non automodes 8 and 16 and in transparent mode 2

The low byte address of a 2-byte address field, or the single address byte of a 1-byte address field is compared with two programmable registers (RAL1, RAL2) and with the group address (fixed value FF_H)

0 ... Group address has been recognized

1 ... RAL1 or RAL2 has been recognized

Note: RSTAB corresponds to the last received HDLC frame; it is duplicated into RFIFOB for every frame (last byte of frame).

If several frames are contained in the RFIFOB the corresponding status information for each frame should be evaluated from the FIFO contents (last byte) as RSTAB only refers to last frame in the FIFO.

4.6.14 TMB -Test Mode Register B-Channel

Value after reset: 00_H

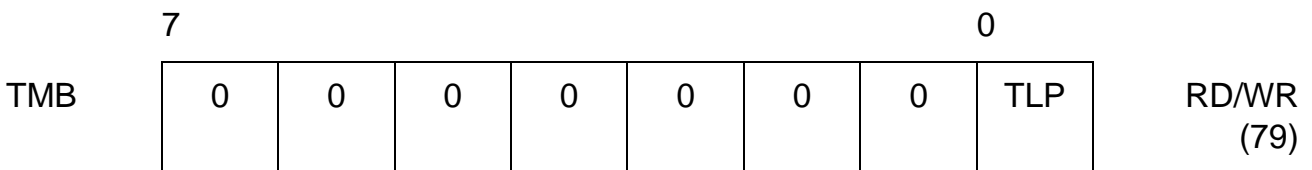

TLP ... Test Loop

The TX path of layer-2 is internally connected with the RX path of layer-2. Data coming from the layer 1 controller will not be forwarded to the layer 2 controller.

4.6.15 RFIFOB - Receive FIFO B-Channel

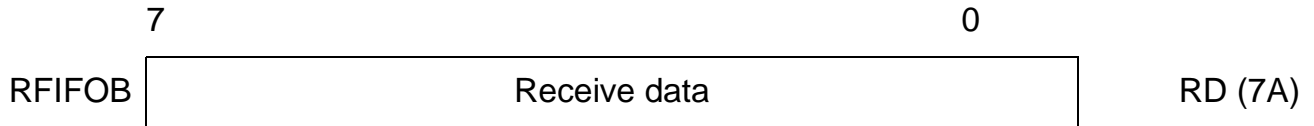

A read access to this register gives access to the “current” FIFO location selected by an internal pointer which is automatically incremented after each read access.

The RFIFOB contains up to 128 bytes of received data.

After an ISTAB.RPF interrupt, a complete data block is available. The block size can be 8 or 16 bytes depending on the EXMB.RFBS setting.

After an ISTAB.RME interrupt, the number of received bytes can be obtained by reading the RBCLB register.

4.6.16 XFIFOB - Transmit FIFO B-Channel

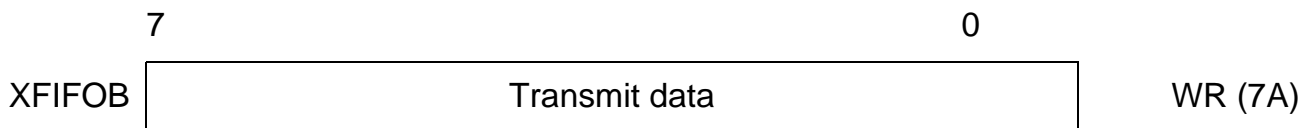

A write access to this register gives access to the “current” FIFO location selected by an internal pointer which is automatically incremented after each write access.

The total XFIFO size is 128 byte and data blocks with up to 32 bytes of transmit data can be written to the XFIFOB following an ISTAB.XPR interrupt.

5 Electrical Characteristics

5.1 Absolute Maximum Ratings

Parameter	Symbol	Limit Values		Unit
		min.	max.	
Ambient temperature under bias	T_A	0	+70	°C
Storage temperature	T_{STG}	- 55	150	°C
Input/output voltage on any pin with respect to ground	V_S	- 0.3	5.25	V
Maximum voltage on any pin with respect to ground	V_{max}		5.5	V

Note: Stresses above those listed here may cause permanent damage to the device. Exposure to absolute maximum rating conditions for extended periods may affect device reliability.

Maximum ratings are absolute ratings; exceeding only one of these values may cause irreversible damage to the integrated circuit.

The supply voltage must show a monotonic rise.

5.2 DC Characteristics
 $V_{DD}/V_{SS} = 3.3 \text{ V} \pm 5\%$; $T_A = 0 \text{ to } 70 \text{ }^\circ\text{C}$

Parameter	Symbol	Limit Values			Unit	Test Condition
		min.	typ.	max.		
H-input level (except pin SR1/2)	V_{IH}	2.0		5.5	V	
L-input level (except pin SR1/2)	V_{IL}	- 0.3		0.8	V	
H-output level (except pin XTAL2, SX1/2)	V_{OH}	2.4			V	$I_{OH} = - 4.5 \text{ mA}$ (AD0-7) $I_{OH} = - 400 \text{ } \mu\text{A}$ (all others)
L-output level (except pin XTAL2, SX1/2)	V_{OL}			0.45	V	$I_{OL} = 6 \text{ mA}$ (DU, DD, C768) $I_{OL} = 4.5 \text{ mA}$ (\overline{ACL} , AUX7, AUX6, AD0-7) $I_{OL} = 2 \text{ mA}$ (all others)
Input leakage current Output leakage current (all pins except SX1/2,SR1/2,XTAL1/2, AUX7/6)	I_{LI} I_{LO}			± 1 ± 1	μA μA	$0\text{V} < V_{IN} < V_{DD}$ $0\text{V} < V_{OUT} < V_{DD}$
Input leakage current Output leakage current (AUX7/6)	I_{LI} I_{LO}	50 50		200 200	μA μA	$0\text{V} < V_{IN} < V_{DD}$ $0\text{V} < V_{OUT} < V_{DD}$ (only if AUX7/6 is input or output/open- drain; not relevant if output/push-pull)
Power supply current- Power Down - Clocks Off	I_{PD1}			300	μA	Inputs at V_{SS} / V_{DD} No output loads except SX1,2 (50 Ω)
- Clocks On	I_{PD2}			3	mA	
Power supply current - S operational (96 kHz)	I_{OP1} I_{OP2}			30 30	mA mA	DCL= 1536 kHz DCL= 4096 kHz
- B1= 00 _H , B2= FF _H , D= 0	I_{OP3}			25	mA	DCL= 1536 kHz

5.3 Capacitances

$T_A = 25\text{ }^\circ\text{C}$, $V_{DD} = 3.3\text{ V} \pm 5\%$, $V_{SSA} = 0\text{ V}$, $V_{SS} = 0\text{ V}$, $f_c = 1\text{ MHz}$, unmeasured pins grounded.

Parameter	Symbol	Limit Values		Unit	Remarks
		min.	max.		
Input Capacitance	C_{IN}		7	pF	All pins except SX1,2 and XTAL1,2
I/O Capacitance	$C_{I/O}$		7	pF	
Output Capacitance against V_{SS}	C_{OUT}		10	pF	pins SX1,2

5.4 Oscillator Specification

Recommended Oscillator Circuits

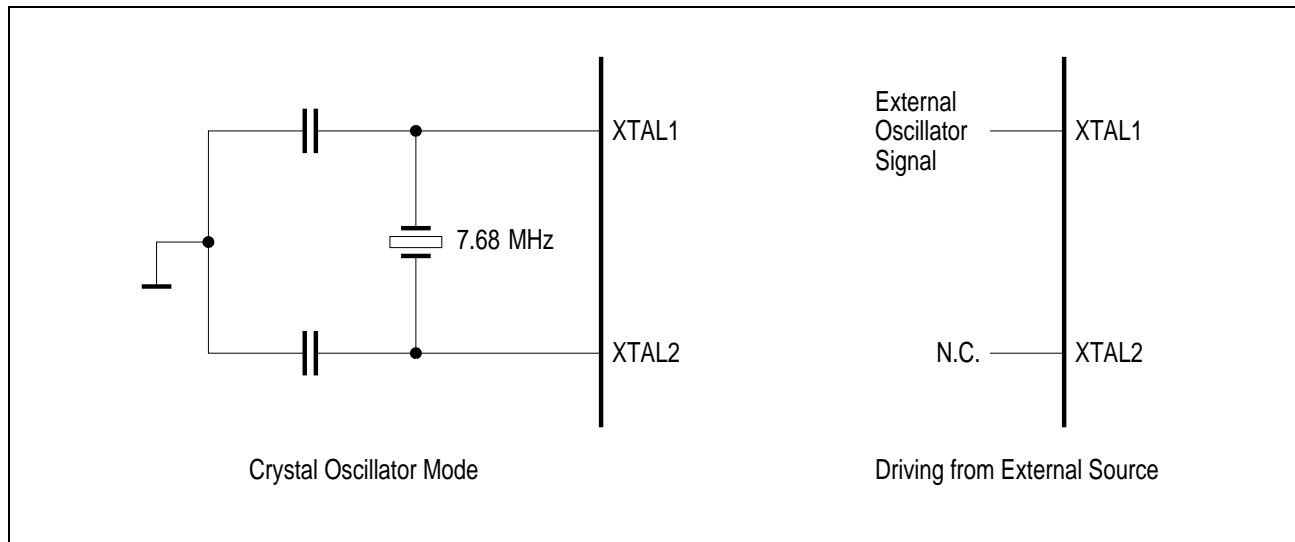

Figure 82 Oscillator Circuits

Parameter	Symbol	Limit Values	Unit
Frequency	f	7.680	MHz
Frequency calibration tolerance		max. 100	ppm
Load capacitance	C_L	max. 40	pF
Oscillator mode		fundamental	

Note: It is important to note that the load capacitance depends on the recommendation of the crystal specification. Typical values are 22 ... 33 pF.

XTAL1 Clock Characteristics (external oscillator input)

Parameter	Limit Values	
	min.	max.
Duty cycle	1:2	2:1

5.5 AC Characteristics

$T_A = 0$ to 70 °C, $V_{DD} = 3.3$ V \pm 5 %

Inputs are driven to 2.4 V for a logical "1" and to 0.45 V for a logical "0". Timing measurements are made at 2.0 V for a logical "1" and 0.8 V for a logical "0". The AC testing input/output waveforms are shown in **figure 83**.

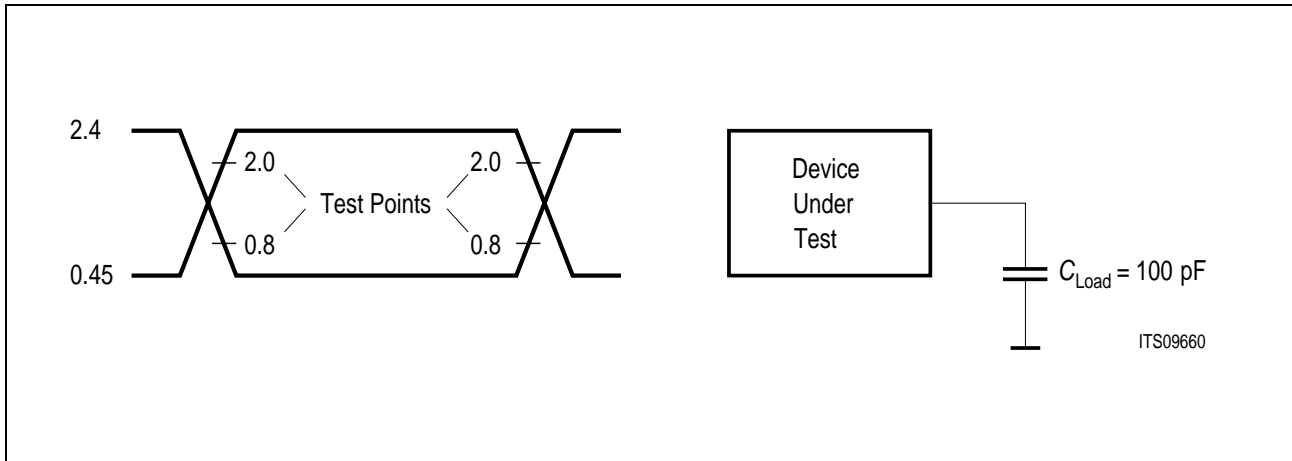

Figure 83 Input/Output Waveform for AC Tests

5.6 IOM-2 Interface Timing

Data is transmitted with the rising edge of DCL and sampled with its falling edge. Below figure shows double clock mode timing (the length of a timeslot is 2 DCL cycles), however, the timing parameters are valid both in single and double clock mode. For the direction of DU,DD (input or output) please refer to [Chapter 3.4](#).

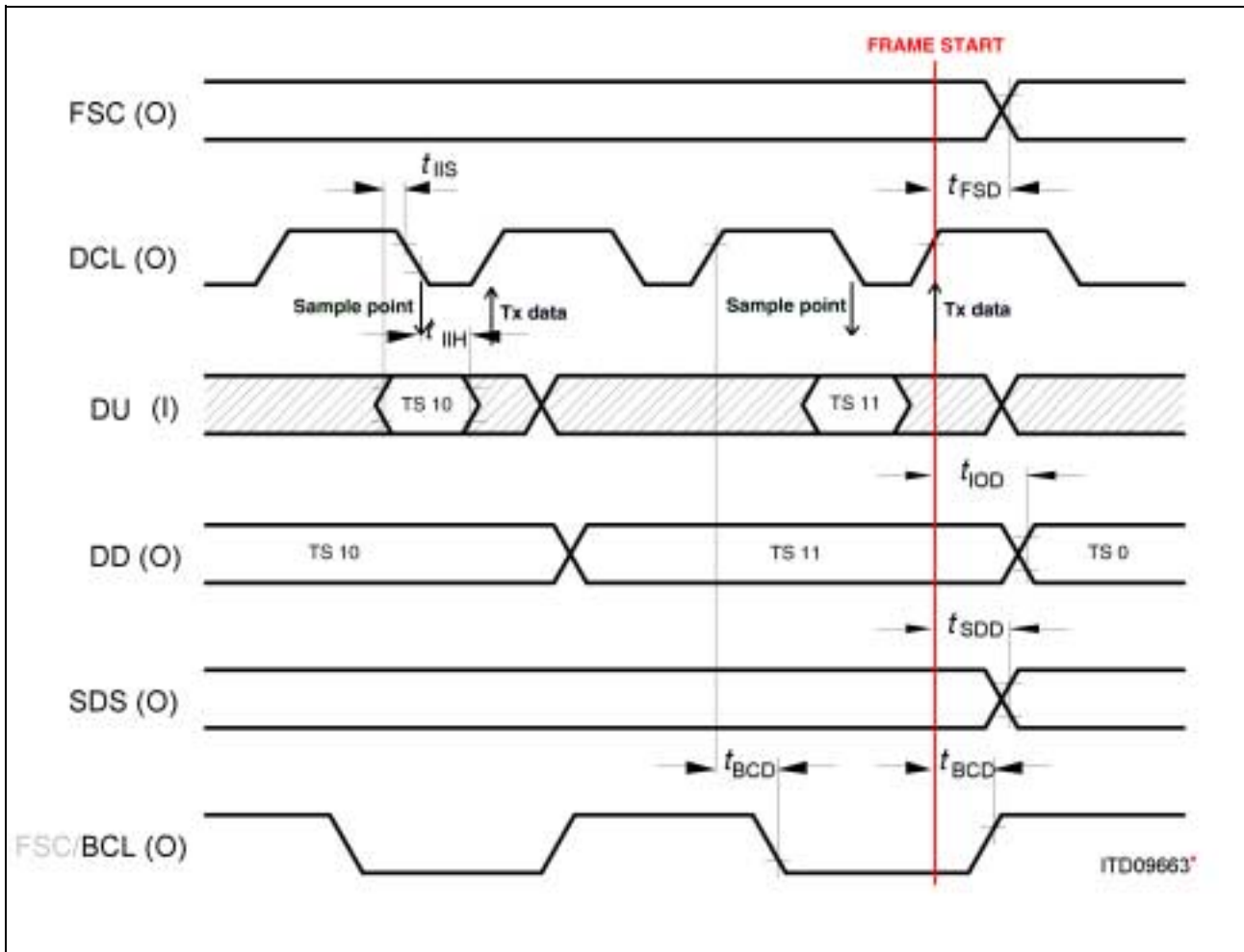

Figure 84 IOM-2 Timing (TE mode)

Electrical Characteristics

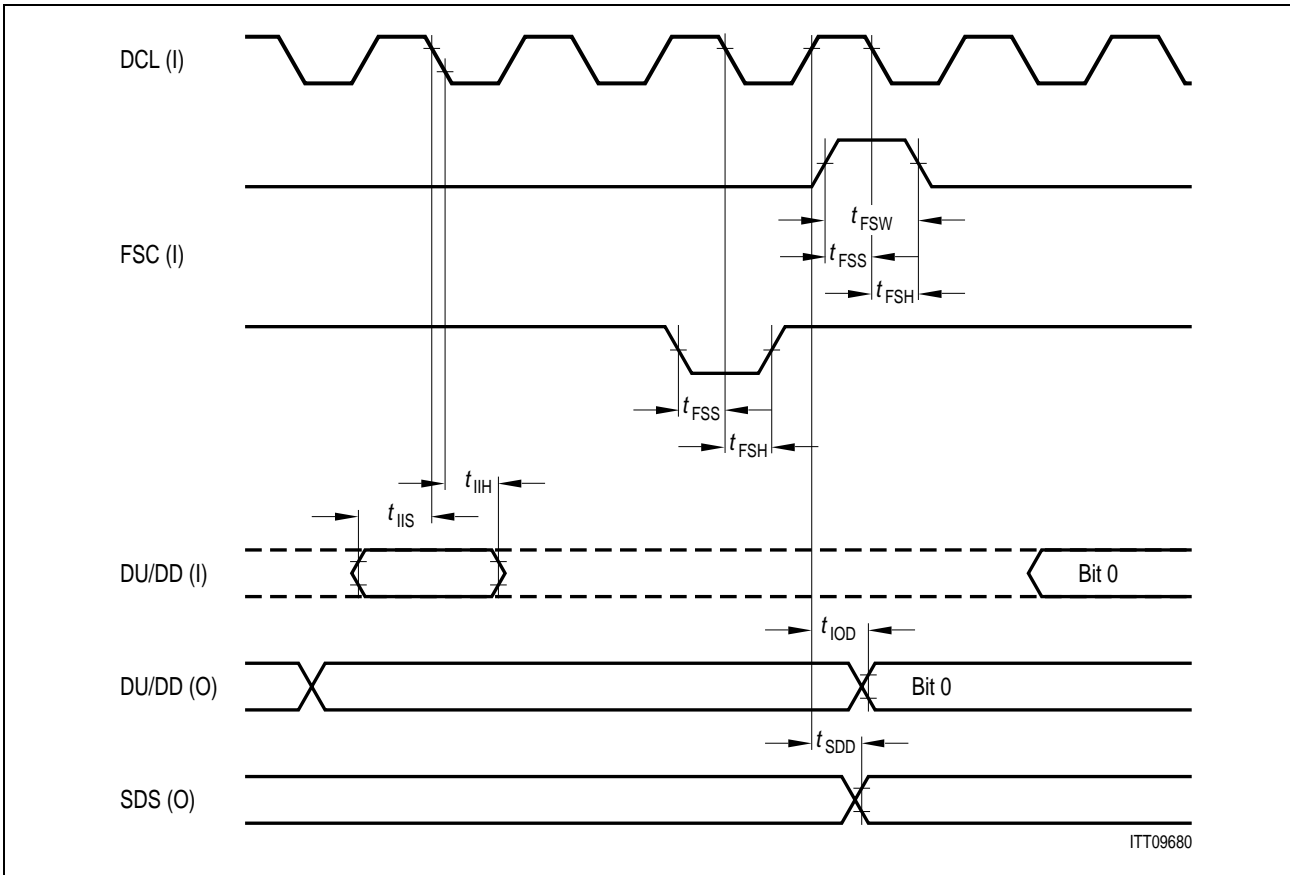

Figure 85 IOM-2 Timing (LT-S, LT-T, NT mode)

Parameter	Symbol	Limit Values		Unit
		min.	max.	
IOM output data delay	t_{IOD}		60	ns
IOM input data setup	t_{IIS}	4		ns
IOM input data hold	t_{IIH}	3		ns
FSC strobe delay	t_{FSD}	-135	15	ns
Strobe signal delay	t_{SDD}		50	ns
BCL / FSC delay	t_{BCD}		30	ns
Frame sync setup	t_{FSS}	20		ns
Frame sync hold	t_{FSH}	30		ns
Frame sync width	t_{FSW}	40		ns

Note: Min. value in synchronous state, max. value in non-synchronous state. This results in a phase shift of FSC when the S-Bus gets activated, this is the FSC signal is shifted by 135 ns. This applies only to TE mode.

DCL Clock Output Characteristics

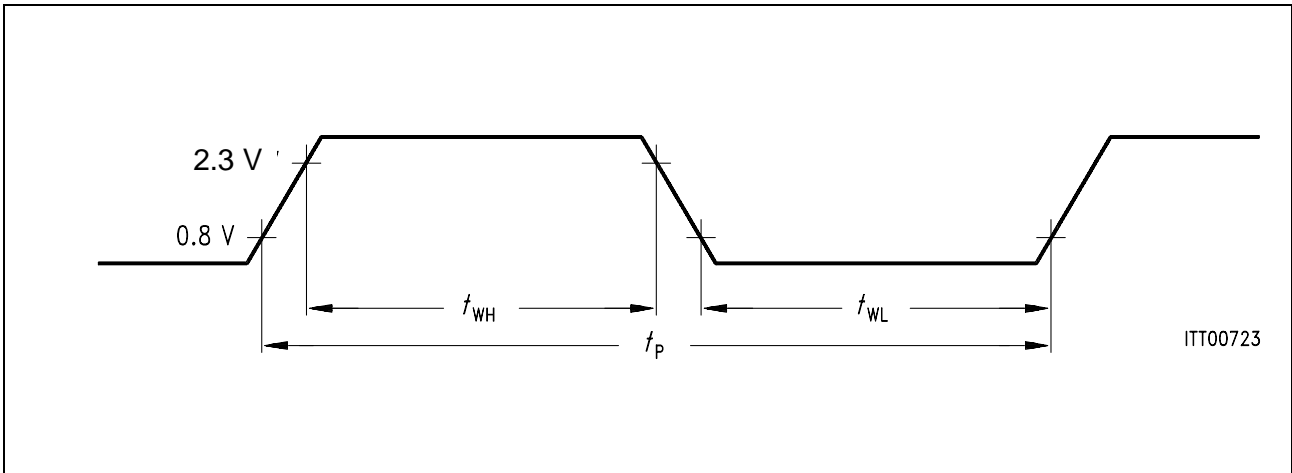

Figure 86 Definition of Clock Period and Width

Symbol	Limit Values			Unit	Test Condition
	min.	typ.	max.		
t_p	585	651	717	ns	osc \pm 100 ppm
t_{WH}	260	325	391	ns	osc \pm 100 ppm
t_{WL}	260	325	391	ns	osc \pm 100 ppm

DCL Clock Input Characteristics

Parameter	Limit Values		Unit
	min.	max.	
Duty cycle	40	60	%

5.7 Microcontroller Interface Timing

5.7.1 Serial Control Interface (SCI) Timing

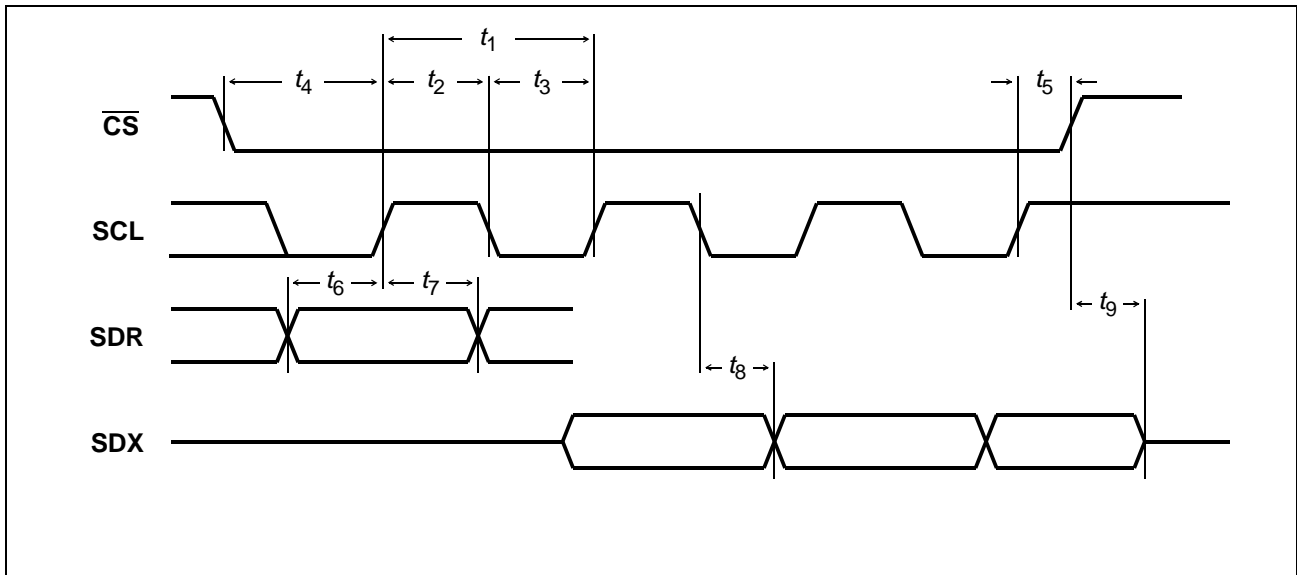

Figure 87 SCI Interface

Parameter SCI Interface	Symbol	Limit values		Unit
		min.	max.	
SCL cycle time	t_1	200		ns
SCL high time	t_2	100		ns
SCL low time	t_3	100		ns
\overline{CS} setup time	t_4	2		ns
\overline{CS} hold time	t_5	10		ns
SDR setup time	t_6	10		ns
SDR hold time	t_7	6		ns
SDX data out delay	t_8		30	ns
\overline{CS} high to SDX tristate	t_9		40	ns

5.7.2 Parallel Microcontroller Interface Timing

Siemens/Intel Bus Mode

The data read and write timing is the same for multiplexed and non multiplexed bus operation (**Figure 88** and **Figure 89**). **Figure 90** shows the corresponding address timing in multiplexed mode and **Figure 91** in non multiplexed mode.

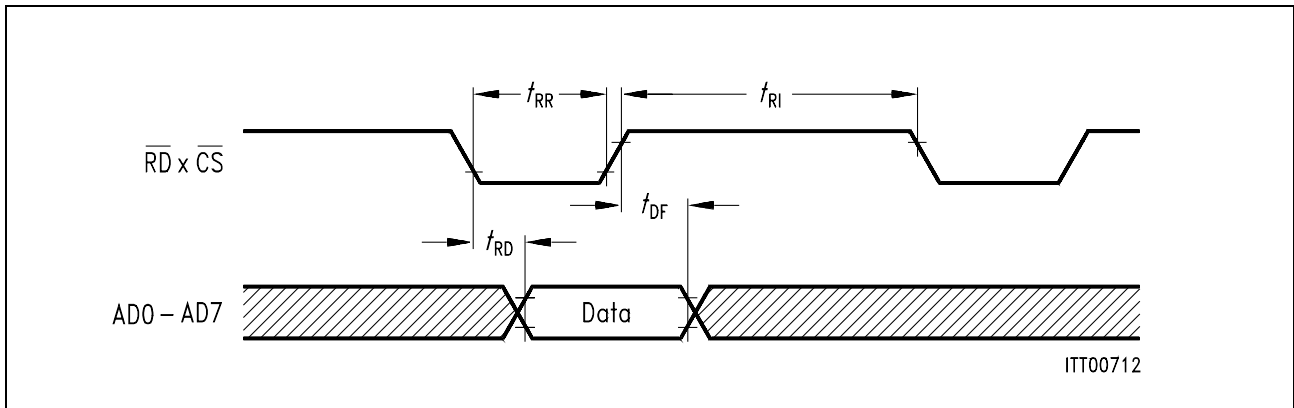

Figure 88 Microprocessor Read Cycle

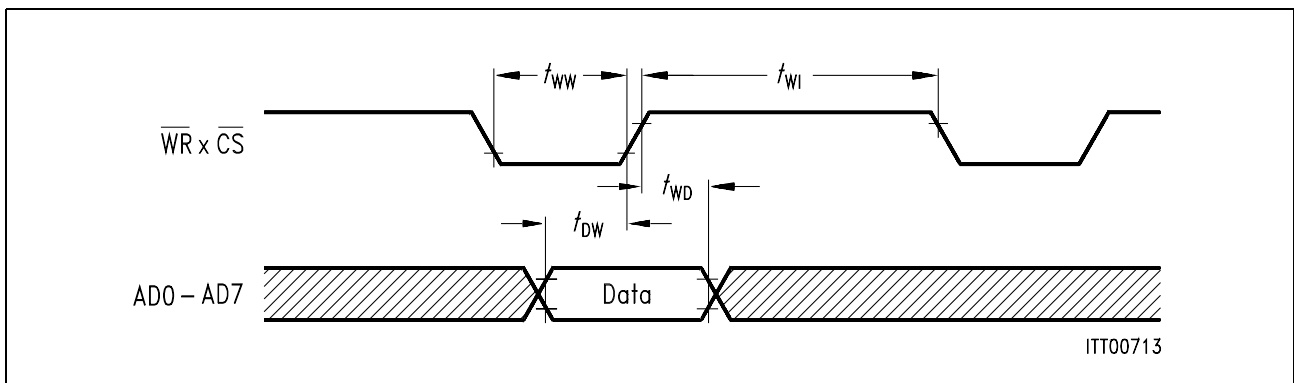

Figure 89 Microprocessor Write Cycle

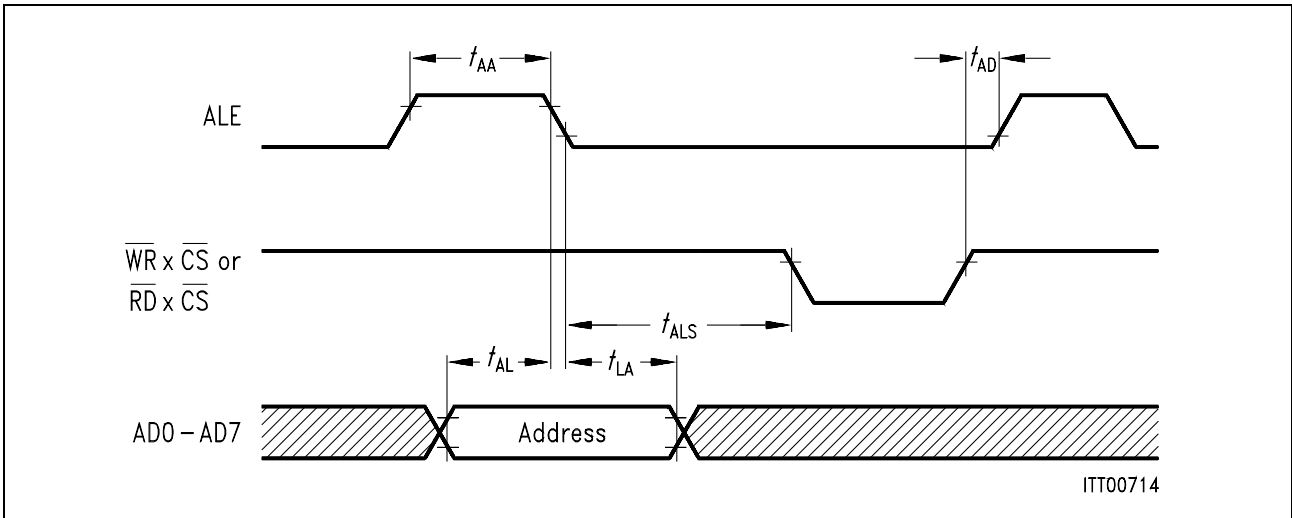

Figure 90 Multiplexed Address Timing

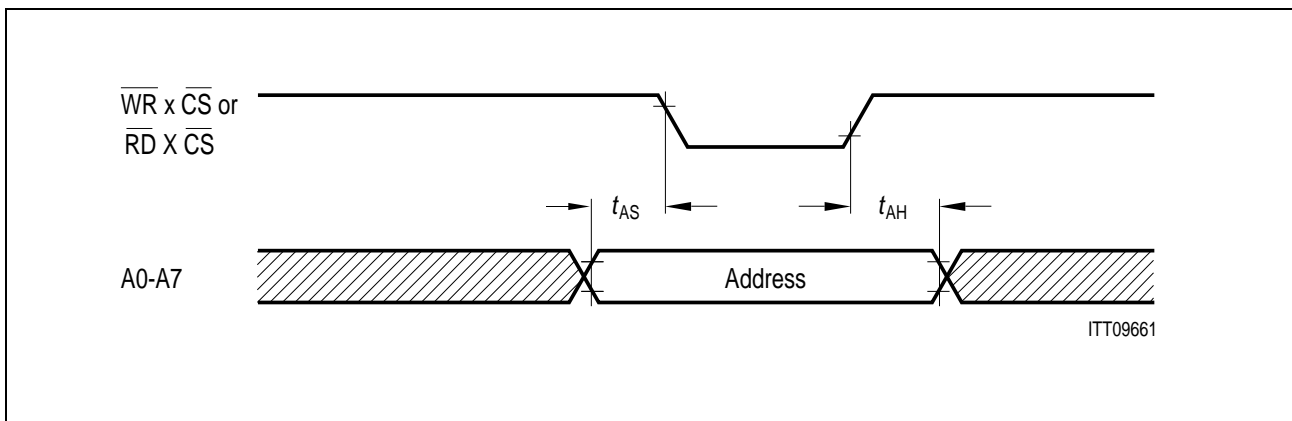

Figure 91 Non-Multiplexed Address Timing

Motorola Bus Mode

The Motorola Bus is non multiplexed. The data timing is shown in [Figure 92](#) (read) and [Figure 93](#) (write). The corresponding address timing (for both read and write) is shown in [Figure 94](#).

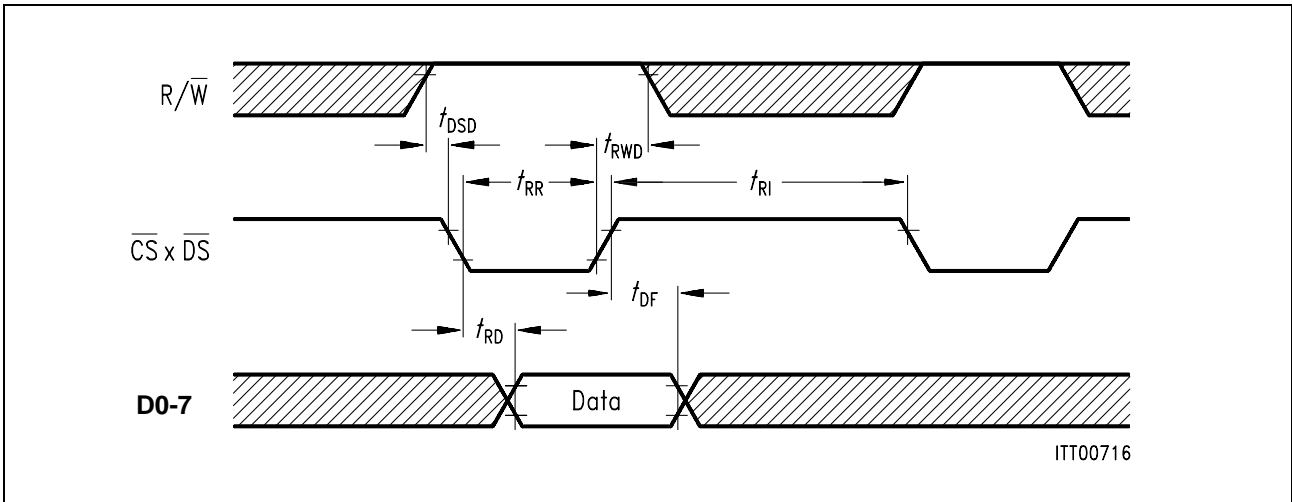

Figure 92 Microprocessor Read Timing

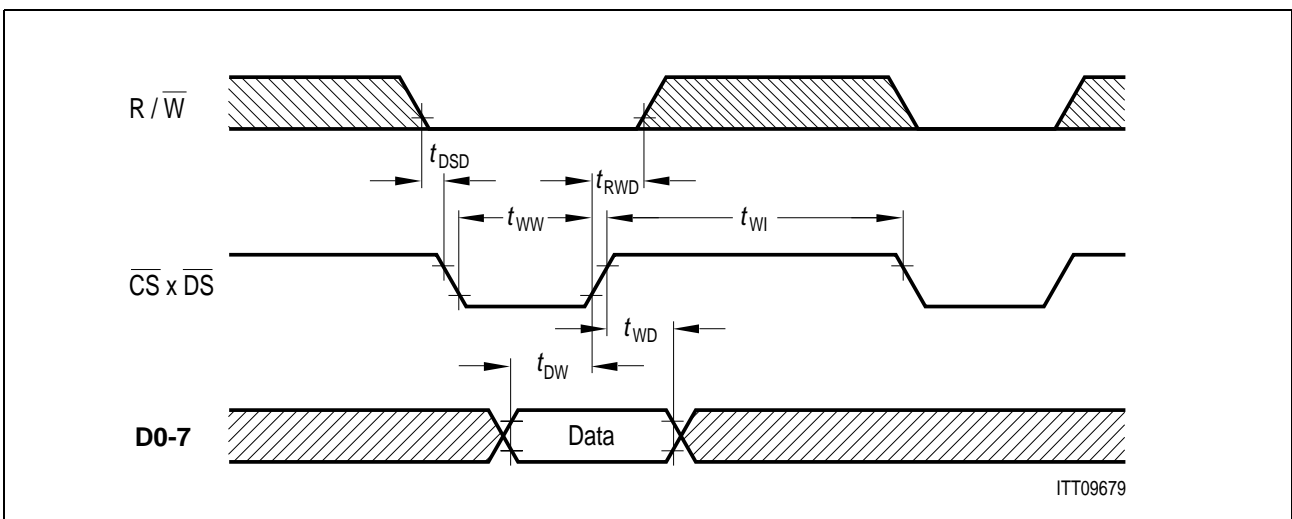

Figure 93 Microprocessor Write Cycle

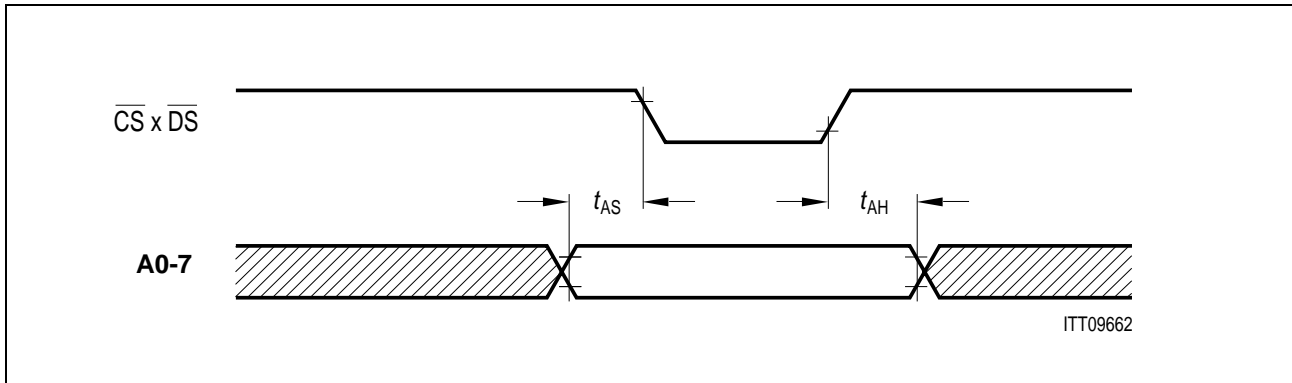

Figure 94 Non-Multiplexed Address Timing

Microprocessor Interface Timing

Parameter	Symbol	Limit Values		Unit
		min.	max.	
ALE pulse width	t_{AA}	20		ns
Address setup time to ALE	t_{AL}	5		ns
Address hold time from ALE	t_{LA}	3		ns
Address latch setup time to \overline{WR} , \overline{RD}	t_{ALS}	10		ns
Address setup time	t_{AS}	10		ns
Address hold time	t_{AH}	3		ns
ALE guard time	t_{AD}	15		ns
\overline{DS} delay after R/\overline{W} setup	t_{DSD}	3		ns
\overline{RD} pulse width	t_{RR}	100		ns
Data output delay from \overline{RD}	t_{RD}		80	ns
Data float from \overline{RD}	t_{DF}		25	ns
\overline{RD} control interval	t_{RI}	70		ns
\overline{W} pulse width	t_{WW}	10		ns
Data setup time to $\overline{W} \times \overline{CS}$	t_{DW}	10		ns
Data hold time $\overline{W} \times \overline{CS}$	t_{WD}	2		ns
\overline{W} control interval	t_{WI}	70		ns
R/\overline{W} hold from $\overline{CS} \times \overline{DS}$ inactive	t_{RWD}	2		ns

5.8 Multiframe Synchronisation Timing

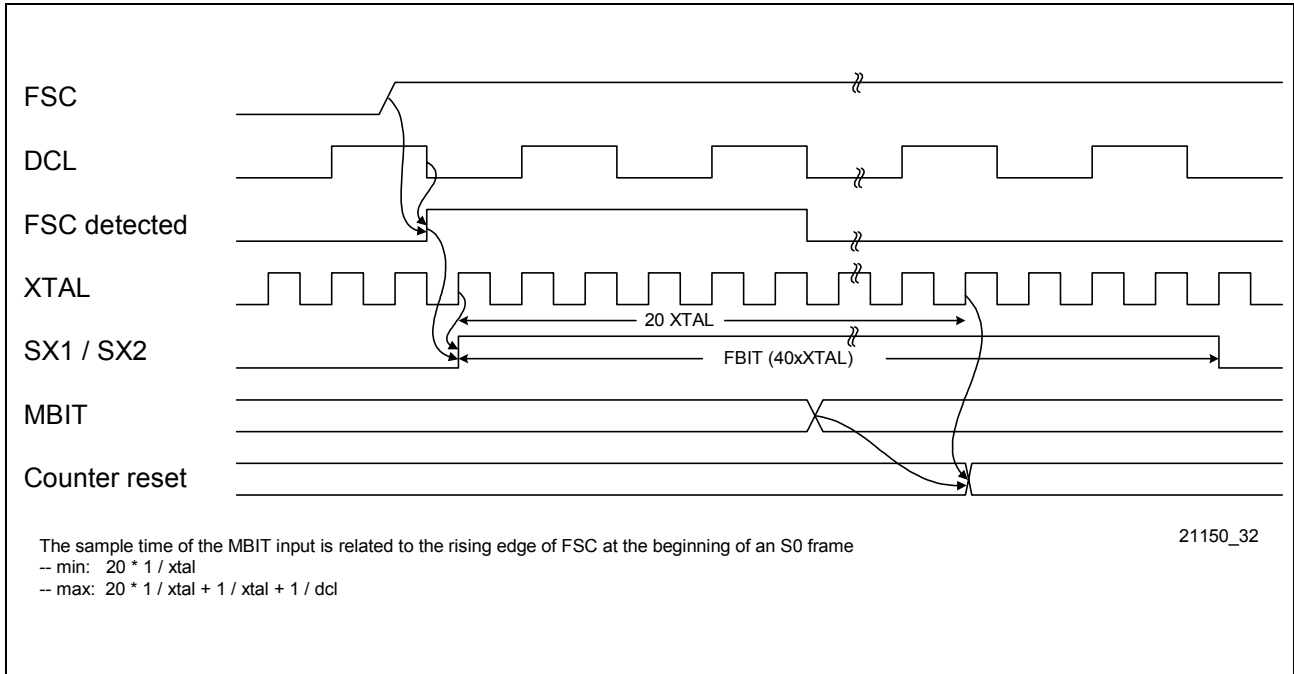

Figure 95 Sampling Time in LT-S/NT Mode (M-Bit Input)

5.9 Reset

Parameter	Symbol	Limit Values	Unit	Test Conditions
		min.		
Length of active low state	t_{RES}	4	ms	Power On/Power Down to Power Up (Standby)
		2 x DCL clock cycles		During Power Up (Standby)

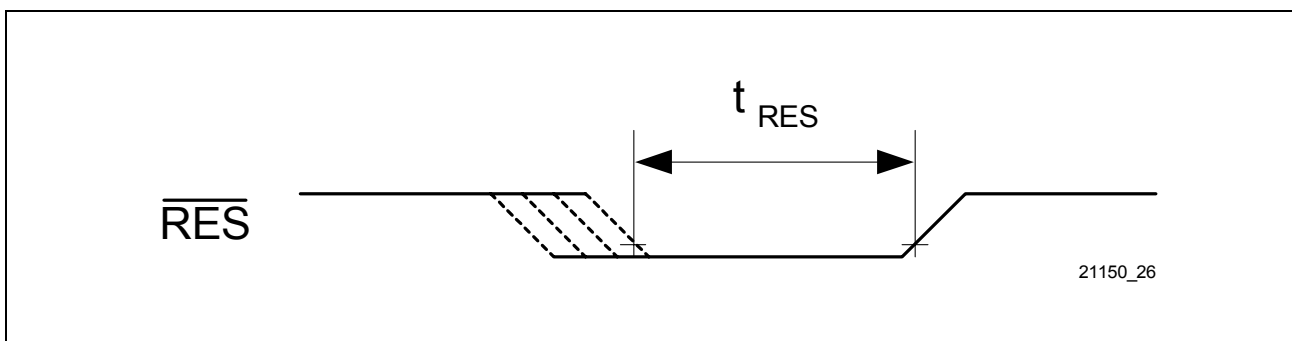

Figure 96 Reset Signal \overline{RES}

5.10 S-Transceiver

Parameter	Symbol	Limit Values			Unit	Test Condition
		min.	typ.	max.		
V _{DD} = 3.3 V ± 5%; V _{SS} = 0 V; T _A = 0 to 70 °C						
Absolute value of output pulse amplitude V _{SX2} – V _{SX1}	V _X			1.17	V	R _L = ∞
Transmitter output current	I _X			26	mA	R _L = 5.6 Ω
Transmitter output impedance (S _{X1,2})	Z _X	10			kΩ	Inactive or during binary one; during binary zero R _L = 50 Ω
		0			Ω	
Receiver Input impedance (S _{R1,2})	Z _R	30			kΩ	V _{DD} = 3.3 V

5.11 Recommended Transformer Specification

Parameter	Symbol	Limit Values			Unit	Test Condition
		min.	typ.	max.		
Transformer ratio			1:1			
Main inductance	L	25			mH	no DC current, 10 kHz
		20			mH	2.5 mA DC current, 10 kHz
Leakage inductance	L _L			8	μH	NT/LT-S mode, 10 kHz
				6	μH	TE/LT-T mode, 10 kHz
Capacitance between primary and secondary side	C			80	pF	1 kHz
Copper resistance	R	1.7	2.0	2.3	W	

Note: In TE/LT-T mode, at the pulse shape measurement with a load of 400 Ω (e.g. K 1403 approval test "Pulse shape") overshots might occur with a leakage inductance greater than 6 μH.

5.12 Line Overload Protection

The maximum input current for the S-transceiver lines (under overvoltage conditions) is given as a function of the width of a rectangular input current pulse. The destruction limits are shown in **Figure 97**.

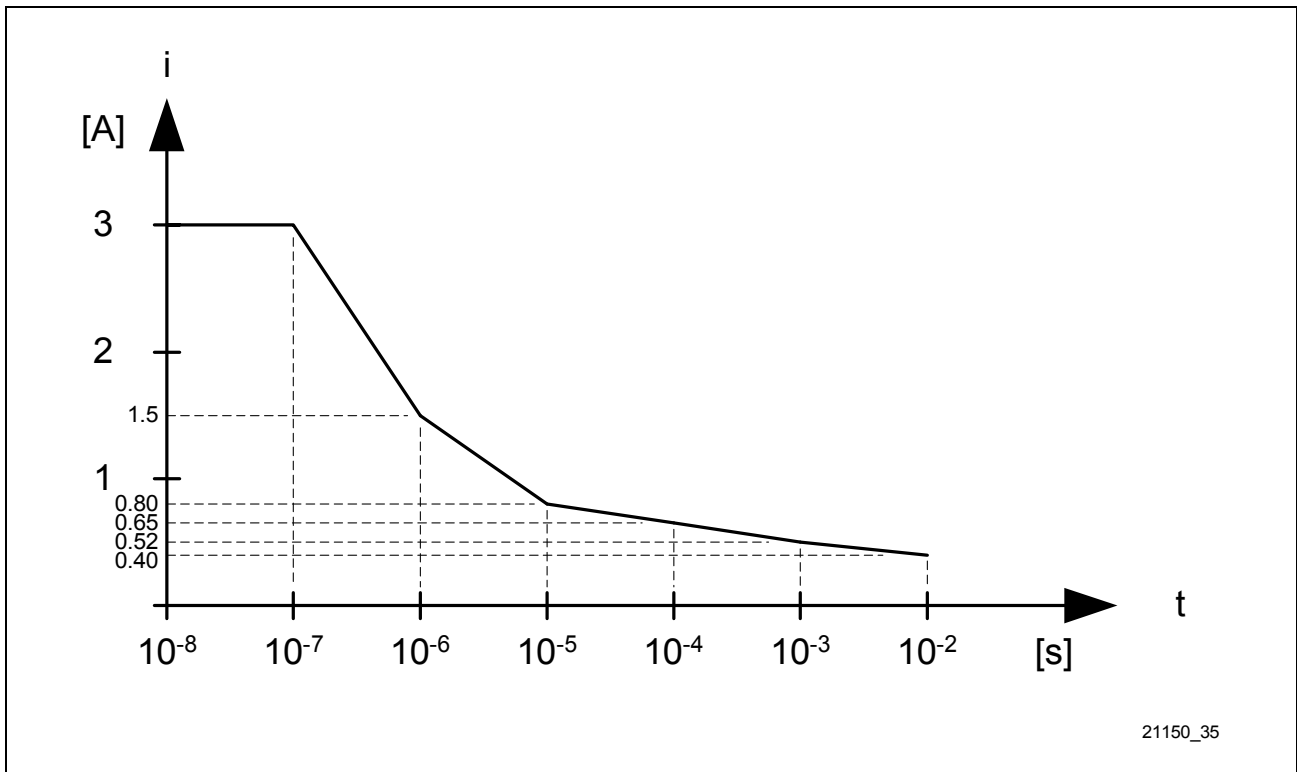

Figure 97 Maximum Line Input Current

5.13 EMC / ESD Aspects

To improve performance with respect to EMC and ESD requirements it is recommended to provide additional capacitors in the middle tap of the transformers (see [Figure 98](#) below). The values for C1 and C2 should be in the range 1 ... 10 nF. They can be located either on the chip side of the transformer (option 1) or on the S bus side (option 2), but not on both sides.

This improves EMC immunity according to EN55024 which is mandatory since 2001-07-01.

Note: The figure does not show any other components required for protection circuit in receive and transmit direction as this is not affected by including C1 and C2.

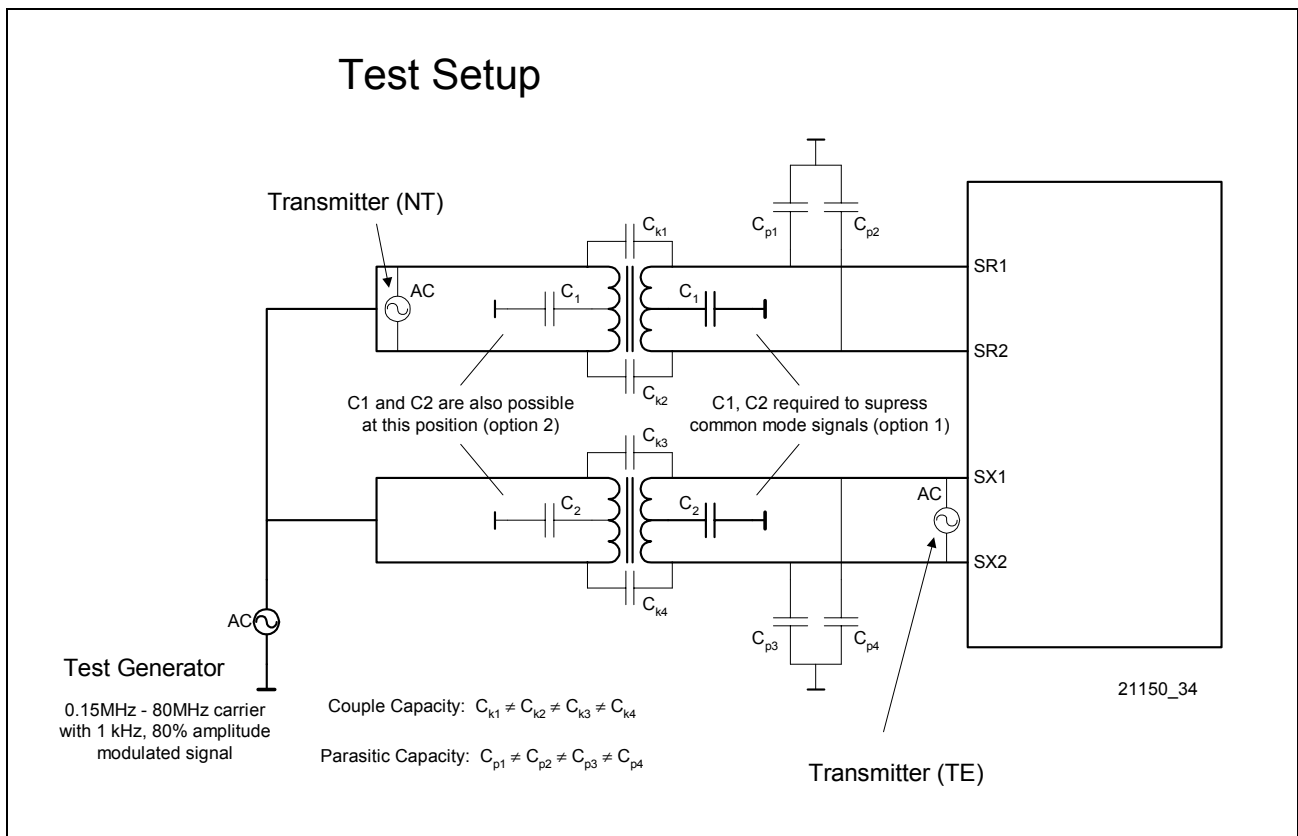
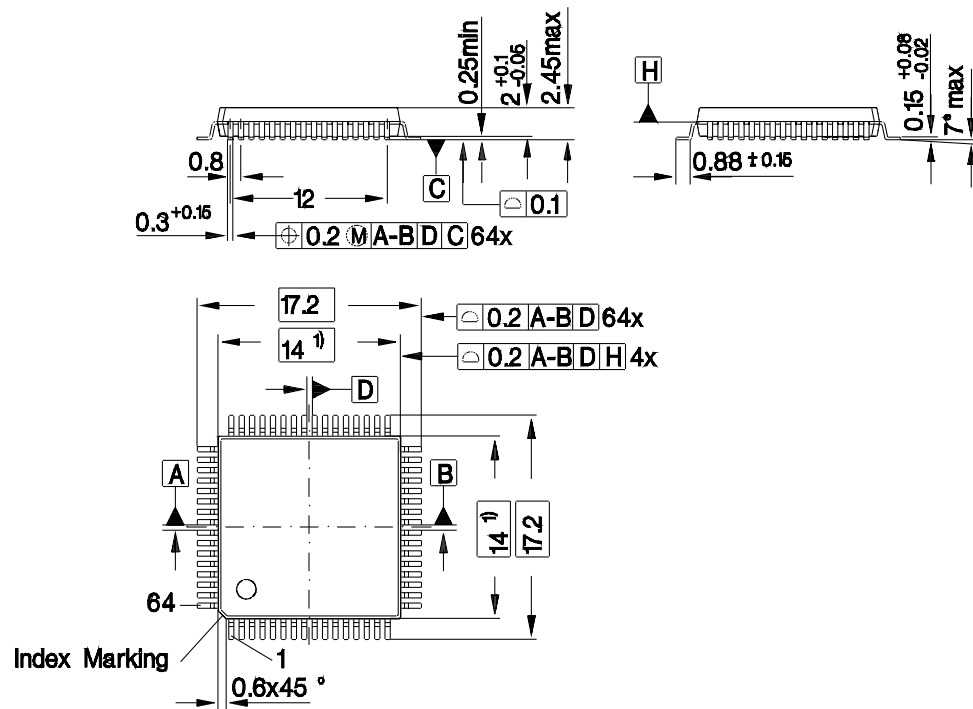

Figure 98 Transformer Circuitry

6 Package Outlines

P-MQFP-64-1 (Plastic Metric Quad Flat Package)



1) Does not include plastic or metal protrusion of 0.25 max. per side

GPM05220

You can find all of the current packages, types of packing, and others on the Infineon Internet Page "Products": <http://www.infineon.com/products>.

SMD = Surface Mounted Device

Dimensions in mm

7 Appendix

D-channel HDLC, C/I-channel Handler

Name	7	6	5	4	3	2	1	0	ADDR	R/W	RES
RFIFOD	D-Channel Receive FIFO								00 _H -1F _H	R	
XFIFOD	D-Channel Transmit FIFO								00 _H -1F _H	W	
ISTAD	RME	RPF	RFO	XPR	XMR	XDU	0	0	20 _H	R	10 _H
MASKD	RME	RPF	RFO	XPR	XMR	XDU	1	1	20 _H	W	FF _H
STARD	XDOV	XFW	0	0	RACI	0	XACI	0	21 _H	R	40 _H
CMDRD	RMC	RRES	0	STI	XTF	0	XME	XRES	21 _H	W	00 _H
MODED	MDS2	MDS1	MDS0	0	RAC	DIM2	DIM1	DIM0	22 _H	R/W	C0 _H
EXMD1	XFBS	RFBS		SRA	XCRC	RCRC	0	ITF	23 _H	R/W	00 _H
TIMR1	CNT			VALUE					24 _H	R/W	00 _H
SAP1	SAPI1						0	MHA	25 _H	W	FC _H
SAP2	SAPI2						0	MLA	26 _H	W	FC _H
RBCLD	RBC7							RBC0	26 _H	R	00 _H
RBCHD	0	0	0	OV	RBC11			RBC8	27 _H	R	00 _H
TEI1	TEI1							EA1	27 _H	W	FF _H
TEI2	TEI2							EA2	28 _H	W	FF _H
RSTAD	VFR	RDO	CRC	RAB	SA1	SA0	C/R	TA	28 _H	R	0F _H
TMD	0	0	0	0	0	0	0	TLP	29 _H	R/W	00 _H
	reserved								2A-2D _H		
CIR0	CODR0				CIC0	CIC1	S/G	BAS	2E _H	R	F3 _H
CIX0	CODX0				TBA2	TBA1	TBA0	BAC	2E _H	W	FE _H

CIR1	CODR1	CICW	CI1E	2F _H	R	FE _H
CIX1	CODX1	CICW	CI1E	2F _H	W	FE _H

Transceiver, Auxiliary Interface

NAME	7	6	5	4	3	2	1	0	ADDR	R/W	RES
TR_CONF0	DIS_TR	BUS	EN_ICV	0	L1SW	0	EXLP	LDD	30 _H	R/W	01 _H
TR_CONF1	0	RPLL_ADJ	EN_SFSC	0	0	x	x	x	31 _H	R/W	
TR_CONF2	DIS_TX	PDS	0	RLP	0	0	SGP	SGD	32 _H	R/W	80 _H
TR_STA	RINF		0	ICV	0	FSYN	0	LD	33 _H	R	00 _H
TR_CMD	XINF			DPRIO	TDDIS	PD	LP_A	0	34 _H	R/W	08 _H
SQRR1	MSYN	MFEN	0	0	SQR11	SQR12	SQR13	SQR14	35 _H	R	40 _H
SQXR1	0	MFEN	0	0	SQX11	SQX12	SQX13	SQX14	35 _H	W	4F _H
SQRR2	SQR21	SQR22	SQR23	SQR24	SQR31	SQR32	SQR33	SQR34	36 _H	R	00 _H
SQXR2	SQX21	SQX22	SQX23	SQX24	SQX31	SQX32	SQX33	SQX34	36 _H	W	00 _H
SQRR3	SQR41	SQR42	SQR43	SQR44	SQR51	SQR52	SQR53	SQR54	37 _H	R	00 _H
SQXR3	SQX41	SQX42	SQX43	SQX44	SQX51	SQX52	SQX53	SQX54	37 _H	W	00 _H
ISTATR	0	x	x	x	LD	RIC	SQC	SQW	38 _H	R	00 _H
MASKTR	1	1	1	1	LD	RIC	SQC	SQW	39 _H	R/W	FF _H
TR_MODE	0	0	0	0	DCH_INH	MODE 2	MODE 1	MODE 0	3A _H	R/W	00 _H
	reserved								3B _H		
ACFG1	OD7	OD6	OD5	OD4	OD3	OD2	OD1	OD0	3C _H	R/W	00 _H
ACFG2	A7SEL	A5SEL	FBS	A4SEL	ACL	LED	EL1	EL0	3D _H	R/W	00 _H

Transceiver, Auxiliary Interface

NAME	7	6	5	4	3	2	1	0	ADDR	R/W	RES
AOE	OE7	OE6	OE5	OE4	OE3	OE2	OE1	OE0	3E _H	R/W	FF _H
ARX	AR7	AR6	AR5	AR4	AR3	AR2	AR1	AR0	3F _H	R	
ATX	AT7	AT6	AT5	AT4	AT3	AT2	AT1	AT0	3F _H	W	00 _H

**IOM Handler (Timeslot , Data Port Selection,
CDA Data and CDA Control Register)**

Name	7	6	5	4	3	2	1	0	ADDR	R/W	RES
CDA10	Controller Data Access Register (CH10)								40 _H	R/W	FF _H
CDA11	Controller Data Access Register (CH11)								41 _H	R/W	FF _H
CDA20	Controller Data Access Register (CH20)								42 _H	R/W	FF _H
CDA21	Controller Data Access Register (CH21)								43 _H	R/W	FF _H
CDA_ TSDP10	DPS	0	0	TSS					44 _H	R/W	00 _H
CDA_ TSDP11	DPS	0	0	TSS					45 _H	R/W	01 _H
CDA_ TSDP20	DPS	0	0	TSS					46 _H	R/W	80 _H
CDA_ TSDP21	DPS	0	0	TSS					47 _H	R/W	81 _H
BCH_ TSDP_ BC1	DPS	0	0	TSS					48 _H	R/W	80 _H
BCH_ TSDP_ BC2	DPS	0	0	TSS					49 _H	R/W	81 _H
reserved									4A _H		
reserved									4B _H		

TR_TSDP_BC1	DPS	0	0	TSS				4C _H	R/W		
TR_TSDP_BC2	DPS	0	0	TSS				4D _H	R/W		
CDA1_CR	0	0	EN_TBM	EN_I1	EN_I0	EN_O1	EN_O0	SWAP	4E _H	R/W	00 _H
CDA2_CR	0	0	EN_TBM	EN_I1	EN_I0	EN_O1	EN_O0	SWAP	4F _H	R/W	00 _H

IOM Handler (Control Registers, Synchronous Transfer Interrupt Control), MONITOR Handler

Name	7	6	5	4	3	2	1	0	ADDR	R/W	RES
TR_CR (CI_CS=0)	EN_D	EN_B2R	EN_B1R	EN_B2X	EN_B1X	CS2-0			50 _H	R/W	
TRC_CR (CI_CS=1)	0	0	0	0	0	CS2-0			50 _H	R/W	
BCH_CR	DPS_D	0	EN_D	EN_BC2	EN_BC1	CS2-0			51 _H	R/W	80 _H
	reserved								52 _H		
DCI_CR (CI_CS=0)	DPS_CI1	EN_CI1	D_EN_D	D_EN_B2	D_EN_B1	CS2-0			53 _H	R/W	
DCIC_CR (CI_CS=1)	0	0	0	0	0	CS2-0			53 _H	R/W	
MON_CR	DPS	EN_MON	0	0	0	CS2-0			54 _H	R/W	
SDS1_CR	ENS_TSS	ENS_TSS+1	ENS_TSS+3	TSS				55 _H	R/W	00 _H	

SDS2_CR	ENS_TSS	ENS_TSS+1	ENS_TSS+3	TSS					56 _H	R/W	00 _H
IOM_CR	SPU	DIS_AW	CI_CS	TIC_DIS	EN_BCL	CLKM	DIS_OD	DIS_IOM	57 _H	R/W	08 _H
STI	STOV ₂₁	STOV ₂₀	STOV ₁₁	STOV ₁₀	STI ₂₁	STI ₂₀	STI ₁₁	STI ₁₀	58 _H	R	00 _H
ASTI	0	0	0	0	ACK ₂₁	ACK ₂₀	ACK ₁₁	ACK ₁₀	58 _H	W	00 _H
MSTI	STOV ₂₁	STOV ₂₀	STOV ₁₁	STOV ₁₀	STI ₂₁	STI ₂₀	STI ₁₁	STI ₁₀	59 _H	R/W	FF _H
SDS_CONF	0	0	0	0	DIOM_INV	DIOM_SDS	SDS2_BCL	SDS1_BCL	5A _H	R/W	00 _H
MCDA	MCDA21		MCDA20		MCDA11		MCDA10		5B _H	R	FF _H
MOR	MONITOR Receive Data								5C _H	R	FF _H
MOX	MONITOR Transmit Data								5C _H	W	FF _H
MOSR	MDR	MER	MDA	MAB	0	0	0	0	5D _H	R	00 _H
MOCR	MRE	MRC	MIE	MXC	0	0	0	0	5E _H	R/W	00 _H
MSTA	0	0	0	0	0	MAC	0	TOUT	5F _H	R	00 _H
MCONF	0	0	0	0	0	0	0	TOUT	5F _H	W	00 _H

Interrupt, General Configuration Registers

NAME	7	6	5	4	3	2	1	0	ADDR	R/W	RES
ISTA	ICB	0	ST	CIC	AUX	TRAN	MOS	ICD	60 _H	R	00 _H
MASK	ICB	1	ST	CIC	AUX	TRAN	MOS	ICD	60 _H	W	FF _H
AUXI	0	0	EAW	WOV	TIN2	TIN1	INT1	INT0	61 _H	R	00 _H
AUXM	1	1	EAW	WOV	TIN2	TIN1	INT1	INT0	61 _H	W	FF _H
MODE1	0	0	0	WTC1	WTC2	CFS	RSS2	RSS1	62 _H	R/W	00 _H

Interrupt, General Configuration Registers

NAME	7	6	5	4	3	2	1	0	ADDR	R/W	RES	
MODE2	0	0	0	0	INT_ POL	0	0	PPSDX	63 _H	R/W	00 _H	
ID	0	0	DESIGN							64 _H	R	01 _H
SRES	RES_ CI	RES_ BCH	0	RES_ MON	RES_ DCH	RES_ IOM	RES_ TR	RES_ RSTO	64 _H	W	00 _H	
TIMR2	TMD	0	CNT							65 _H	R/W	00 _H
	reserved								66 _H - 6F _H			

B-channel HDLC Control Registers

Name	7	6	5	4	3	2	1	0	ADDR	R/W	RES
ISTAB	RME	RPF	RFO	XPR	0	XDU	0	0	70 _H	R	10 _H
MASKB	RME	RPF	RFO	XPR	1	XDU	1	1	70 _H	W	FF _H
STARB	XDOV	XFW	0	0	RACI	0	XACI	0	71 _H	R	40 _H
CMDRB	RMC	RRES	0	0	XTF	0	XME	XRES	71 _H	W	00 _H
MODEB	MDS2	MDS1	MDS0	0	RAC	0	0	0	72 _H	R/W	C0 _H
EXMB	1	1	RFBS	SRA	XCRC	RCRC	0	ITF	73 _H	R/W	C0 _H
	reserved								74 _H		
RAH1	RAH1						0	MHA	75 _H	W	00 _H
RAH2	RAH2						0	MLA	76 _H	W	00 _H
RBCLB	RBC7							RBC0	76 _H	R	00 _H
RBCHB	0	0	0	OV	RBC11			RBC8	77 _H	R	00 _H
RAL1	RAL1								77 _H	W	00 _H

RAL2	RAL2								78 _H	W	00 _H
RSTAB	VFR	RDO	CRC	RAB	HA1	HA0	C/R	LA	78 _H	R	0E _H
TMB	0	0	0	0	0	0	0	TLP	79 _H	R/W	00 _H
RFIFOB	B-Channel Receive FIFO								7A _H	R	
XFIFOB	B-Channel Transmit FIFO								7A _H	W	
	reserved								7B _H 7F _H		

Index
A

A4SEL bit 190
 A5SEL bit 190
 A7SEL bit 190
 Absolute maximum ratings 229
 AC characteristics 233
 ACFG1 register 190
 ACFG2 register 190
 ACKxy bits 206
 ACL bit 190
 Activation 89
 Activation indication - pin ACL 45
 Activation LED 45
 Activation/deactivation of IOM-2 interface
 130
 AOE register 192
 Appendix 250
 Applications 20
 AR7-0 bits 192
 Architecture 30
 ARX register 192
 ASTI register 206
 Asynchronous awake 132
 AT7-0 bits 193
 ATX register 193
 AUX bit 211
 AUXI register 212
 Auxiliary interface 133
 AUXM register 213

B

BAC bit 178
 BAS bit 177
 BCH_CR registers 198
 BCH_TSDP_BC1/2 registers 195
 BUS bit 180
 Bus operation modes 37

C

C/I channel 119
 C/R bit 175, 226
 Capacitances 231

CDA_TSDPxy registers 195
 CDAX_CR register 196
 CDAXy registers 194
 CFS bit 213
 CI_CS bit 203
 CI1E bit 179
 CIC bit 211
 CIC1/0 bits 177
 CICW bit 179
 CIR0 register 177
 CIR1 register 179
 CIX0 register 178
 CIX1 register 179
 CLKM bit 203
 Clock generation 66
 CMDR register 167
 CMDRB register 220
 CNT bits 172, 217
 CODR0 bits 177
 CODR1 bits 179
 CODX0 bits 178
 CODX1 bits 179
 Control of layer-1 71
 Controller data access 97
 CRC bit 175, 226

D

D_EN_B2/1 bits 199
 D_EN_D bit 199
 DC characteristics 230
 DCH_INH bit 188
 D-channel access control
 Intelligent NT 126
 S-bus D-channel control in LT-T 126
 S-bus priority mechanism 123
 TIC bus 121
 DCI_CR register 199
 Deactivation 89
 Delay between IOM-2 and S 55
 DESIGN bits 216
 Device architecture 30
 DIM2-0 bits 168
 Direct address mode 37

Index

DIS_AW bit 203
DIS_IOM bit 203
DIS_OD bit 203
DIS_TR bit 180
DIS_TX bit 181
DPRIO bit 184
DPS bit 195, 201
DPS_CI1 bit 199
DPS_D bit 198

E

EA1 bit 174
EA2 bit 174
EAW bit 212
EL1/0 bits 190
Electrical characteristics 229
EN_B2/1R bits 197
EN_B2/1X bits 197
EN_BC2/1 bits 198
EN_BCL bit 203
EN_CI1 bit 199
EN_D bit 197, 198
EN_I0 bit 196
EN_I1 bit 196
EN_ICV bit 180
EN_MON bit 201
EN_O0 bit 196
EN_O1 bit 196
EN_SFSC bit 181
EN_TBM bit 196
ENS_TSSx bits 202
Exchange awake 42
EXLP bit 180
EXMB register 222
EXMD1 register 170
Extended transparent mode 151
External reset input 42

F

FBS bit 190
Features 17
FSYN bit 183
Functional blocks 30

H

HA1/0 bits 226
HDLC controllers
 Access to IOM channels 151
 Data reception 137
 Data transmission 146
 Extended transparent mode 151
 Interrupts 153
 Receive frame structure 144
 Test functions 154
 Transmit frame structure 151

I

I/O lines 133
ICB bit 211
ICD bit 211
ICV bit 183
ID register 216
Indirect address mode 37
INT_POL bit 215
INT1/0 bits 212
Intelligent NT 126
Interrupt input 134
Interrupt structure 39
IOM_CR register 203
IOM-2 92
 Frame structure (LT) 94
 Frame structure (NT) 94
 Frame structure (TE) 93
 Handler 95
 Interface Timing 234
 LT-S, LT-T, NT modes 92
 Monitor channel 110
 TE mode 92
ISTA register 211
ISTAB register 218
ISTAD register 165
ISTATR register 187
ITF bit 170, 222

J

Jitter 69

Index

L

L1SW bit 180
LA bit 226
LD bit 183, 187
LDD bit 180
LED bit 190
LED output 45
Level detection 63
Logic symbol 19
Looping data 98
LP_A bit 184
LT-T mode 126

M

MAB bit 208
MAC bit 210
MASK register 212
MASKB register 219
MASKD register 166
MASKTR register 188
M-Bit synchronisation 52
MCDA register 207
MCDAXy bits 207
MCONF register 210
MDA bit 208
MDR bit 208
MDS2-0 bits 168, 221
MER bit 208
MFEN bit 185, 186
MHA bit 172, 223
Microcontroller interface timing 237
Microcontroller interfaces 32
MIE bit 209
MLA bit 173, 223
MOCR register 209
MODE1 register 213
MODE2 register 215
MODE2-0 bits 188
MODEB register 221
MODED register 168
MON_CR register 201
Monitor channel

Error treatment 114
Handshake procedure 111
Interrupt logic 119
Master device 116
Slave device 117
Time-out procedure 118

Monitoring data 102
Monitoring TIC bus 102
MOR register 208
MOS bit 211
MOSR register 208
MOX register 208
MRC bit 209
MRE bit 209
MSTA register 210
MSTI register 206
MSYN bit 185
Multiframe sync timing 242
Multiframe synchronization 52
Multiframing 50
MXC bit 209

O

OD7-0 bits 190
OE7-0 bits 192
Oscillator 232
Oscillator clock output 70
OV bit 173, 224
Overview 13

P

Package Outlines 248
Parallel microcontroller interface 37
PD bit 184
PDS bit 181
Pin configuration 21
PPSDX bit 215

R

RAB bit 175, 226
RAC bit 168, 221
RACI bit 167, 219
RAH1 register 223

Index

- RAH2 register 223
- RAL1 register 225
- RAL2 register 225
- RBC11-8 bits 173, 224
- RBC7-0 bits 173, 224
- RBCHB register 224
- RBCHD register 173
- RBCLB register 224
- RBCLD register 173
- RCRC bit 170, 222
- RDO bit 175, 226
- Receive PLL 69
- Register description 156
- RES_xxx bits 216
- Reset generation 41
- Reset source selection 41
- Reset timing 243
- RFBS bits 170, 222
- RFIFOB register 228
- RFIFOD register 164
- RFO bit 165, 218
- RIC bit 187
- RINF bits 183
- RLP bit 181
- RMC bit 167, 220
- RME bit 165, 218
- RPF bit 165, 218
- RPLL_ADJ bit 181
- RRES bit 167, 220
- RSS2/1 bits 213
- RSTAB register 226
- RSTAD register 175

- S**
- S/G bit 128, 177
- S/T-Interface 46
 - Circuitry 60
 - Coding 48
 - Delay compensation 63
 - External protection circuitry 60
 - Multiframe synchronization 52
 - Multiframe 50
 - Receiver characteristics 59
 - Transceiver enable/disable 64
 - Transmitter characteristics 58
- SA1/0 bits 175
- SAP1 register 172
- SAP2 register 173
- S-bus priority mechanism 123
- SCI - serial control interface 33
- SCI interface timing 237
- SDS 107
- SDS_CONF register 207
- SDS2/1_BCL bits 207
- SDSx_CR registers 202
- Serial data strobe 107
- SGD bit 181
- SGP bit 181
- Shifting data 98
- SLIP bit 183
- Software reset 42
- SPU bit 203
- SQC bit 187
- SQR1-4 bits 185
- SQR21-24 bits 186
- SQR31-34 bits 186
- SQR41-44 bits 187
- SQR51-54 bits 187
- SQRR1 register 185
- SQRR2 register 186
- SQRR3 register 187
- SQW bit 187
- SQX1-4 bits 186
- SQX21-24 186
- SQX31-34 bits 186
- SQX41-44 bits 187
- SQX51-54 bits 187
- SQXR1 register 186
- SQXR2 register 186
- SQXR3 register 187
- SRA bit 170, 222
- SRES register 216
- ST bit 211
- STARB register 219
- STARD register 167
- State machine

Index

LT-S mode 80
NT mode 84
TE and LT-T mode 73
STI bit 167
STI register 205
STIxy bits 205, 206
Stop/Go bit 128, 177
STOVxy bits 205, 206
Strobed data clock 107
Subscriber awake 42
SWAP bit 196
Synchronous transfer 103

T

TA bit 175
TBA2-0 bits 178
TDDIS bit 184
TEI1 register 174
TEI2 register 174
Test functions 64
Test signals 155
TIC bus 121
TIC_DIS bit 203
Timer 43
Timer 1 44
Timer 2 44
TIMR1 register 172
TIMR2 register 217
TIN2/1 bits 212
TLP bit 177, 227
TMB register 227
TMD bit 217
TMD register 177
TOUT bit 210
TR_CMD register 184
TR_CONF0 register 180
TR_CONF1 register 181
TR_CONF2 register 181
TR_CR register 197
TR_MODE register 188
TR_STA register 183
TR_TSDP_BC1/2 registers 195
TRAN bit 211

Transceiver enable/disable 64
Transformer specification 245
TSS bits 195, 202
Typical applications 20

V

VALUE bits 172
VFR bit 175, 226

W

Watchdog timer 42
WOV bit 212
WTC1/2 bits 213

X

XACI bit 167, 219
XCRC bit 170, 222
XDOV bit 167, 219
XDU bit 165, 218
XFBS bit 170, 222
XFIFOB register 228
XFIFOD register 164
XFW bit 167, 219
XINF bits 184
XME bit 167, 220
XMR bit 165
XPR bit 165, 218
XRES bit 167, 220
XTF bit 167, 220

<http://www.infineon.com>

Published by Infineon Technologies AG

Looking for pricing, stock, or lifecycle information?

Click below to explore more details on WIN SOURCE:

- ⊖ [View PEB3086FV1.4 on WIN SOURCE](#)
- ⊖ [Infineon Technologies Information](#)

Optimize Your Supply Chain with WIN SOURCE Solutions

- ✓ Global Sourcing Solution
- ✓ Obsolete Management
- ✓ Cost Control Management
- ✓ Shortage Management
- ✓ Alternative Solution
- ✓ Excess Inventory Management