



**THE DATASHEET OF
PE-68280NL**



SMT Current Sense Transforms

PE-68XXXNL Series



- ⌚ **Height:** 7.1mm Max
- ⌚ **Footprint:** 14.6mm x 12.6mm Max
- ⌚ **Current Rating:** up to 15A
- ⌚ **Frequency Range:** 50kHz to 500kHz

Electrical Specifications @ 25°C - Operating Temperature -40°C to +130°C

Part ^{5,6} Number	Turns Ratio	Current ² Rating	Secondary Inductance (mH MIN)	DCR (mΩ MAX)		Hipot (V _{RMS})
				Primary (1,3-2,4)	Secondary (5-6)	
PE-68210NL	1:1:50	15	3.8	1.15	380	500
PE-68280NL	1:1:100	15	14.8	1.15	930	500
PE-68383NL	1:1:200	15	59.2	1.15	3900	500

- Notes:**
- The temperature of the component (ambient temperature plus temperature rise) must be within the specified operating temperature range.
 - The maximum current rating is based upon temperature rise of the component and represents the DC current which will cause a typical temperature rise of 40°C with no airflow when both one turn windings connected in parallel.
 - To calculate the value of the terminating resistor (R_t) use the following formula:

$$R_t (\Omega) = V_{REF} * N / (I_{peak_primary})$$
 - The peak flux density of the device must remain below 2000 Gauss. To calculate the peak flux density for uni-polar current use following formula:

$$BPK = 14.29 * V_{REF} * (Duty_Cycle_Max) * 10^5 / (N * Freq_kHz)$$
* for bi-polar current applications divide BPK (as calculated above) by 2.
 - Optional Tape & Packaging can be ordered by adding a "T" suffix to the part number (i.e. PE-68210NL becomes PE-68210NLT). Pulse complies to the industry standard tape and reel specification EIA481.
 - The "NL" suffix indicates an RoHS-compliant part number. Non-NL suffixed parts are not necessarily RoHS compliant, but are electrically and mechanically equivalent to NL versions. If a part number does not have the "NL" suffix, but an RoHS compliant version is required, please contact Pulse for availability.

Mechanical

Schematic

PE-XXXXNL

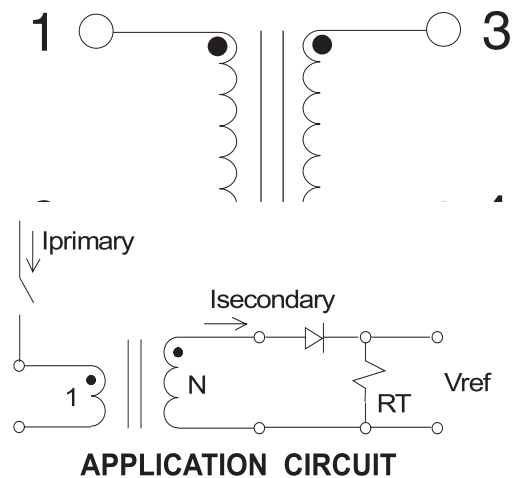
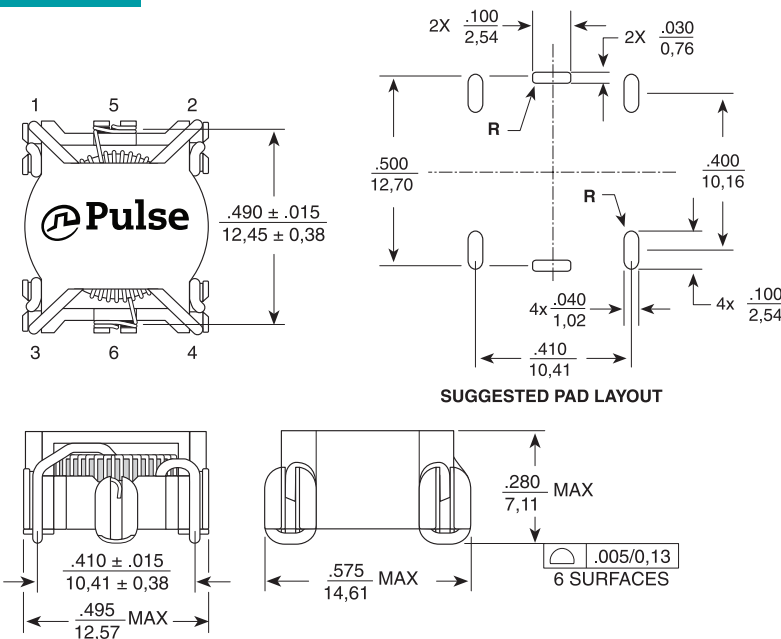

Dimensions: Inches / mm
 Unless otherwise specified,
 all tolerances are: ±0.010 / 0.25

SMT Current Sense Transforms

PE-68XXXNL Series



For More Information

Pulse Worldwide Headquarters

15255 Innovation Drive Ste 100
San Diego, CA 92128
U.S.A.

Tel: 858 674 8100
Fax: 858 674 8262

Pulse Europe

Pulse Electronics GmbH
Am Rottland 12
58540 Meinerzhagen
Germany

Tel: 49 2354 777 100
Fax: 49 2354 777 168

Pulse China Headquarters

Pulse Electronics (ShenZhen) CO., LTD
D708, Shenzhen Academy of
Aerospace Technology,
The 10th Keji South Road,
Nanshan District, Shenzhen,
P.R. China 518057

Tel: 86 755 33966678
Fax: 86 755 33966700

Pulse North China

Room 2704/2705
Super Ocean Finance Ctr.
2067 Yan An Road West
Shanghai 200336
China

Tel: 86 21 62787060
Fax: 86 2162786973

Pulse South Asia

3 Fraser Street 0428
DUO Tower
Singapore 189352

Tel: 65 6287 8998
Fax: 65 6280 0080

Pulse North Asia

1F., No.111 Xiyuan Road
Zhongli District
Taoyuan City 32057
Taiwan (R.O.C)

Tel: 886 3 4356768
Fax: 886 3 4356820

Performance warranty of products offered on this data sheet is limited to the parameters specified. Data is subject to change without notice. Other brand and product names mentioned herein may be trademarks or registered trademarks of their respective owners. © Copyright, 2019. Pulse Electronics, Inc. All rights reserved.

Looking for pricing, stock, or lifecycle information?

Click below to explore more details on WIN SOURCE:

 [View PE-68280NL on WIN SOURCE](#)

 [Pulse Information](#)

Optimize Your Supply Chain with WIN SOURCE Solutions

-  Global Sourcing Solution
-  Obsolete Management
-  Cost Control Management
-  Shortage Management
-  Alternative Solution
-  Excess Inventory Management