

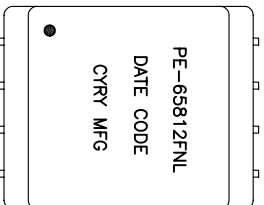

# THE DATASHEET OF PE-65812FNL





ILITY

) +125°C

ITY AT 245°C REFLOW PROFILE

O MOISTURE SENSITIVE

MAXIMUM THROUGH REFLOW SOLDER

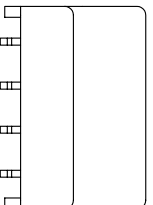

NG ADD A "T" SUFFIX

12FNL BECOMES PE-65812FNLT).

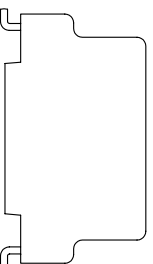

FINAL OUTLINE

All rights reserved. Pulse confidential & proprietary. (06/30/14)

TLA DRAWING	PS DRAWING	SHEET	PART NO.	DATASHEET REV.
PE-65812FNL-10	PS-2752.001-B	1 OF 3	PE-65812FNL	A

ELECTRICAL CHARACTERISTICS AT +25°C UNLESS OTHER SPECIFIED

PARAMETER	SPECIFICATIONS					
OPERATING TEMP	0°C - 70 °C					
POLARITY	PER SCHEMATIC					
TURNS RATIO @10 KHZ, 0.2 VRMS	$\frac{(1-4)}{(8-5)} = 1.00 \pm 2\%$					
INDUCTANCE @100 KHZ, 0.02 VRMS	(1-4) = 2.5 mH $\pm 20\%$					
LEAKAGE INDUCTANCE (L <sub>L</sub> ) @100 KHZ, 0.02 VRMS	(1-4) WITH (8-5) SHORTED = 0.35 uH MAXIMUM					
CWV @100 KHZ, 0.02 VRMS	(1-4) TO (8-5) = 40 pF MAXIMUM					
INSERTION LOSS	100 KHz TO 55 MHz					
	-3 dB MAXIMUM					
RETURN LOSS	100 KHz			10 MHz		
	-22 dB MINIMUM			-20 dB MINIMUM		
COMMON MODE REJECTION	100 KHZ	1 MHZ	3 MHZ	6 MHZ	10 MHZ	30 MHZ
	-75 dB	-70 dB	-60 dB	-50 dB	-40 dB	-25 dB
HIPOT:	2000 VAC FOR 60 SECONDS					

All rights reserved. Pulse confidential & proprietary. (06/30/14)

TLA DRAWING	PS DRAWING	SHEET	PART NO.	DATASHEET REV.
PE-65812FNL-10	PS-2752.001-B	2 OF 3	PE-65812FNL	A

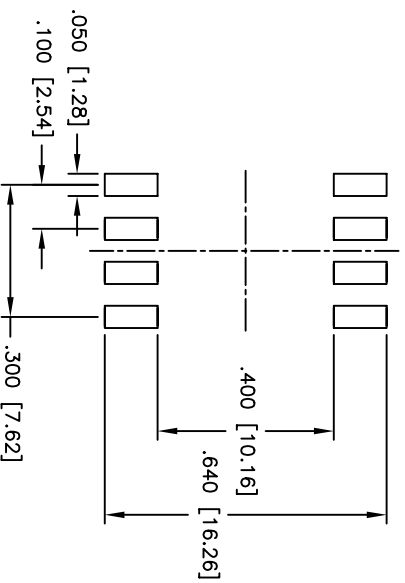
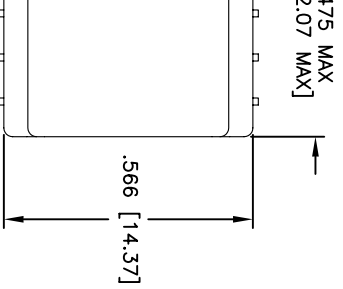

SUGGESTED LAND PATTERN

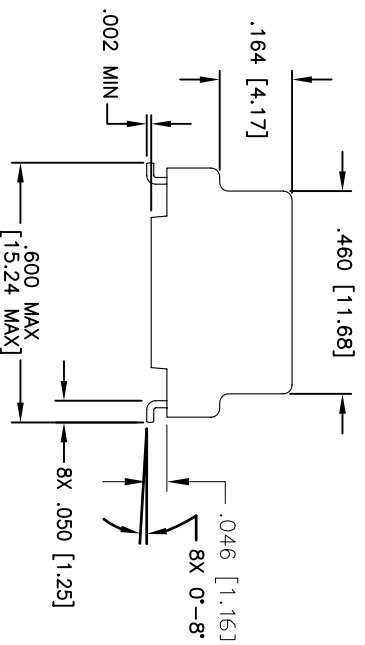
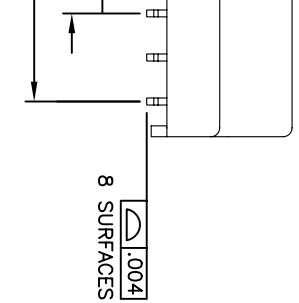

WITH THE FOLLOWING  
REFERENCE ONLY.

All rights reserved. Pulse confidential & proprietary. (06/30/14)

ITLA DRAWING E-65812FNL-10	PS DRAWING PS-2752.001-B	SHEET 3 OF 3	PART NO. PE-65812FNL	DATASHEET REV. A
-------------------------------	-----------------------------	-----------------	-------------------------	---------------------

## Looking for pricing, stock, or lifecycle information?

Click below to explore more details on WIN SOURCE:

- ⊖ [View PE-65812FNL on WIN SOURCE](#)
- ⊖ [Pulse Information](#)

## Optimize Your Supply Chain with WIN SOURCE Solutions

- ✓ Global Sourcing Solution
- ✓ Obsolete Management
- ✓ Cost Control Management
- ✓ Shortage Management
- ✓ Alternative Solution
- ✓ Excess Inventory Management