



**THE DATASHEET OF
PCS3P8504AG**



PCS3P8504A

General Purpose Peak EMI Reduction IC

Functional Description

PCS3P8504A is a versatile, 3.3 V Timing-Safe™ Peak EMI reduction IC. PCS3P8504A accepts an input clock either from a fundamental Crystal or from an external reference (AC or DC coupled to XIN/CLKIN) and locks on to it delivering a 1x modulated clock output. PCS3P8504A has a SSON pin for enabling and disabling Spread Spectrum function.

PCS3P8504A has an SSEXTR pin to select different deviations depending upon the value of an external resistor connected between SSEXTR and GND. Modulation Rate (MR) control selects one of the two different Modulation Rates.

PCS3P8504A operates from a 3.3 V supply, and is available in an 8-pin, WDFN(2 mm x 2 mm) package.

General Features

- 1x, LVCMOS Peak EMI Reduction
- Input frequency:
 - ◆ 15 MHz - 50 MHz
- Output frequency:
 - ◆ 15 MHz - 50 MHz
- Analog Deviation Selection
- ModRate selection option
- Spread Spectrum Enable/Disable
- Supply Voltage: 3.3 V ± 0.3 V
- 8-pin, WDFN 2 mm x 2 mm (TDFN) Package
- These Devices are Pb-Free, Halogen Free/BFR Free and are RoHS Compliant

Application

- PCS3P8504A is targeted for consumer electronics application like DPF, MFP.



ON Semiconductor®

<http://onsemi.com>

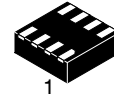

WDFN8
CASE 511AQ

MARKING DIAGRAMS

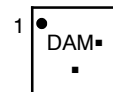

DA = Specific Device Code
M = Date Code
▪ = Pb-Free Device

PIN CONFIGURATION

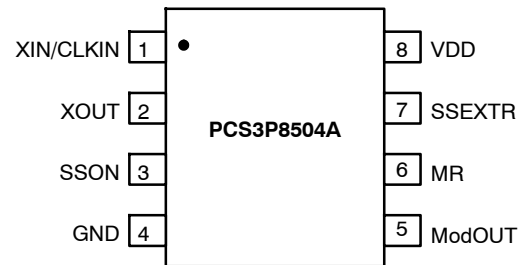

ORDERING INFORMATION

See detailed ordering and shipping information in the package dimensions section on page 5 of this data sheet.

PCS3P8504A

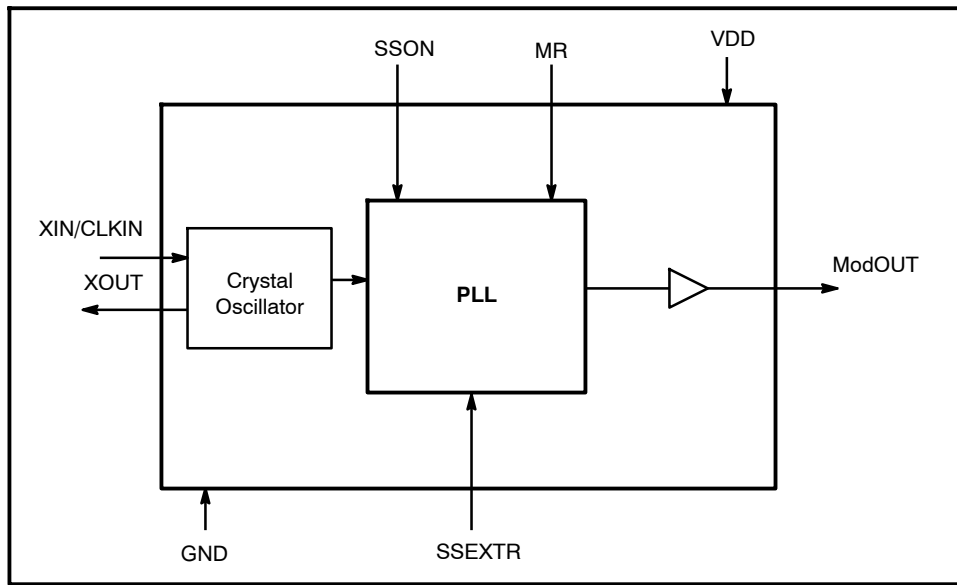

Figure 1. Block Diagram

Table 1. PIN DESCRIPTION

Pin#	Pin Name	Type	Description
1	XIN / CLKIN	I	Crystal connection or External reference clock input.
2	XOUT	O	Crystal connection. If using an external reference, this pin should be left open.
3	SSON	I	Spread Spectrum ON/OFF. Spread Spectrum function enabled when HIGH, disabled when LOW. Has an internal pull-up resistor.
4	GND	P	Ground
5	ModOUT	O	Modulated clock output
6	MR	I	Modulation Rate Select. When LOW selects Low Modulation Rate. Selects High Modulation Rate when pulled HIGH. Has an internal pull-up resistor.
7	SSEXTR	I	Analog Deviation Selection through external resistor to GND.
8	V _{DD}	P	3.3 V supply Voltage.

Table 2. OPERATING CONDITIONS

Symbol	Parameter	Min	Max	Unit
V _{DD}	Supply Voltage	3	3.6	V
T _A	Operating Temperature	0	70	°C
C _L	Load Capacitance		10	pF
C _{IN}	Input Capacitance		7	pF

Table 3. ABSOLUTE MAXIMUM RATING

Symbol	Parameter	Rating	Unit
V _{DD} , V _{IN}	Voltage on any input pin with respect to Ground	-0.5 to +4.6	V
T _{STG}	Storage temperature	-65 to +125	°C
T _s	Max. Soldering Temperature (10 sec)	260	°C

Stresses exceeding Maximum Ratings may damage the device. Maximum Ratings are stress ratings only. Functional operation above the Recommended Operating Conditions is not implied. Extended exposure to stresses above the Recommended Operating Conditions may affect device reliability.

PCS3P8504A

Table 3. ABSOLUTE MAXIMUM RATING

Symbol	Parameter	Rating	Unit
T _J	Junction Temperature	150	°C
T _{DV}	Static Discharge Voltage (As per JEDEC STD22- A114-B)	2	kV

Stresses exceeding Maximum Ratings may damage the device. Maximum Ratings are stress ratings only. Functional operation above the Recommended Operating Conditions is not implied. Extended exposure to stresses above the Recommended Operating Conditions may affect device reliability.

Table 4. DC ELECTRICAL CHARACTERISTICS

Symbol	Parameter	Test Conditions	Min	Typ	Max	Unit
V _{DD}	Supply Voltage		3.0	3.3	3.6	V
V _{IL}	Input LOW Voltage				0.8	V
V _{IH}	Input HIGH Voltage		2.0			V
I _{IL}	Input LOW Current	V _{IN} = 0 V			25	μA
I _{IH}	Input HIGH Current	V _{IN} = V _{DD}			25	μA
V _{OL}	Output LOW Voltage	I _{OL} = 8 mA			0.4	V
V _{OH}	Output HIGH Voltage	I _{OH} = -8 mA	2.4			V
I _{CC}	Static Supply Current	XIN / CLKIN pulled low			50	μA
I _{DD}	Dynamic Supply Current	Unloaded Output			20	mA
Z _o	Output Impedance			30		Ω

Table 5. SWITCHING CHARACTERISTICS

Parameter	Test Conditions	Min	Typ	Max	Unit
Input Frequency* / ModOUT		15		50	MHz
Duty Cycle (Notes 1 and 2)	Measured at V _{DD} / 2	45	50	55	%
Output Rise Time (Notes 1 and 2)	Measured between 20% to 80%			1.8	ns
Output Fall Time (Notes 1 and 2)	Measured between 80% to 20%			1.6	ns
Cycle-to-Cycle Jitter (Note 2)	Unloaded output with SSEXTR OPEN @ 27 MHz		± 150	± 250	ps
PLL Lock Time (Note 2)	Stable power supply, valid clock presented on XIN / CLKIN			3	ms

*Functionality with Crystal is guaranteed by design and characterization. Not 100% tested in production.

1. All parameters are specified with 10 pF loaded outputs.

2. Parameter is guaranteed by design and characterization. Not 100% tested in production.

PCS3P8504A

TYPICAL CRYSTAL SPECIFICATIONS

FUNDAMENTAL AT CUT PARALLEL RESONANT CRYSTAL

Nominal frequency	27 MHz
Frequency tolerance	± 50 ppm or better at 25°C
Operating temperature range	-25°C to +85°C
Storage temperature	-40°C to +85°C
Load capacitance (C_P)	18 pF
Shunt capacitance	7 pF maximum
ESR	25 Ω

NOTE: C_L is the Load Capacitance and R_x is used to prevent oscillations at overtone frequency of the Fundamental frequency.

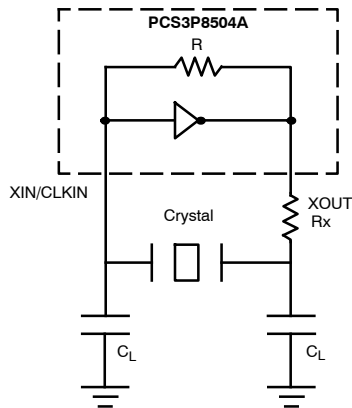

$$C_L = 2 * (C_P - C_S),$$

Where C_P = Load capacitance of crystal from crystal vendor datasheet

C_S = Stray capacitance due to C_{IN} , PCB, Trace etc.

Figure 2. Typical Crystal Interface Circuit

SWITCHING WAVEFORMS

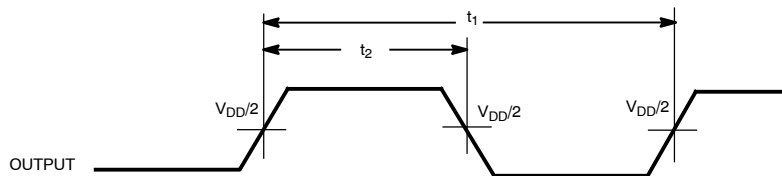

Figure 3. Duty Cycle Timing

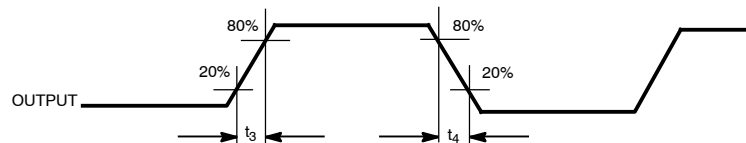
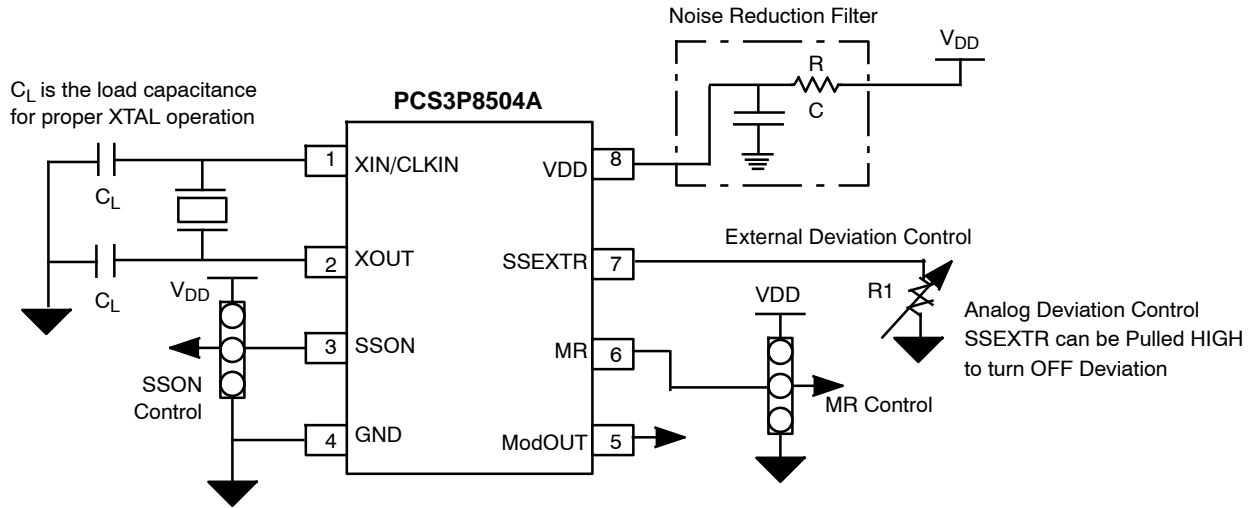

Figure 4. Output Rise/Fall Time

PCS3P8504A



NOTE: SSON (Pin#3) MR (Pin#6): Connect to V_{DD} or GND
Refer to Pin Description table for Functionality details

Figure 5. Application Schematic

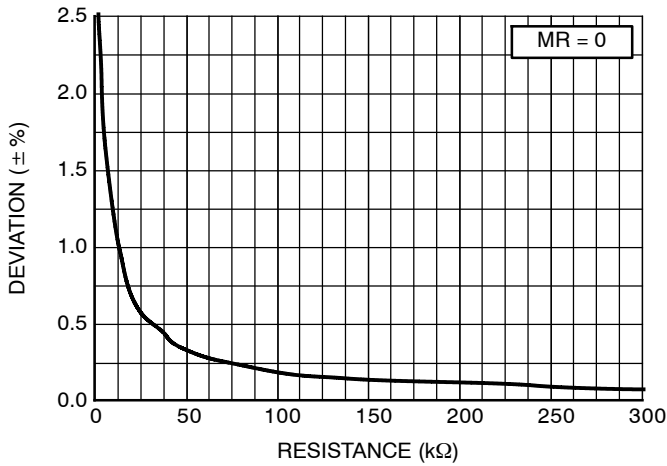

Figure 6. Deviation vs SSEXTR Resistance Chart at 27 MHz

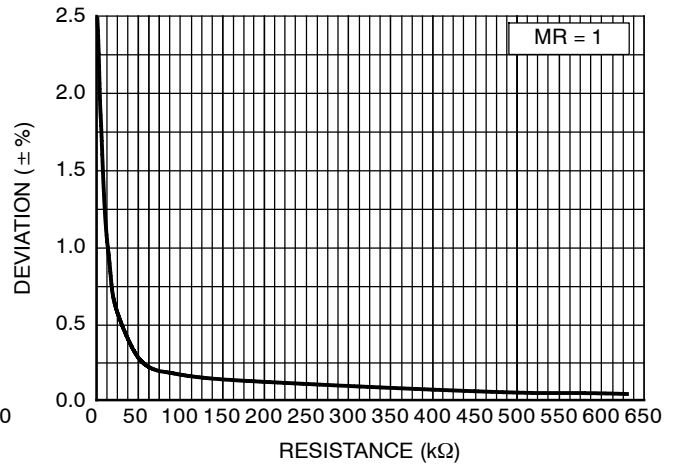

Figure 7. Deviation vs SSEXTR Resistance Chart at 27 MHz

NOTE: Device to Device variation of Deviation is $\pm 10\%$

ORDERING INFORMATION

Part Number	Top Marking	Temperature	Package Type	Shipping [†]
PCS3P8504AG-08CR	DA	0°C to +70°C	8-Pin (2 mm x 2 mm) WDFN(TDFN) (Pb-Free)	Tape & Reel

[†]For information on tape and reel specifications, including part orientation and tape sizes, please refer to our Tape and Reel Packaging Specifications Brochure, BRD8011/D.

*A "microdot" placed at the end of last row of marking or just below the last row toward the center of package indicates Pb-Free.

PCS3P8504A

PACKAGE DIMENSIONS

WDFN8 2x2, 0.5P
CASE 511AQ-01
ISSUE A

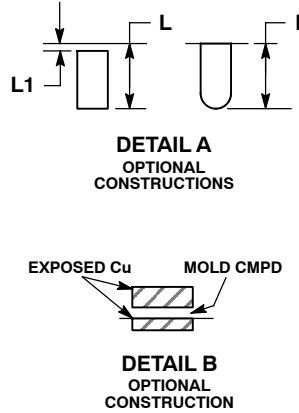
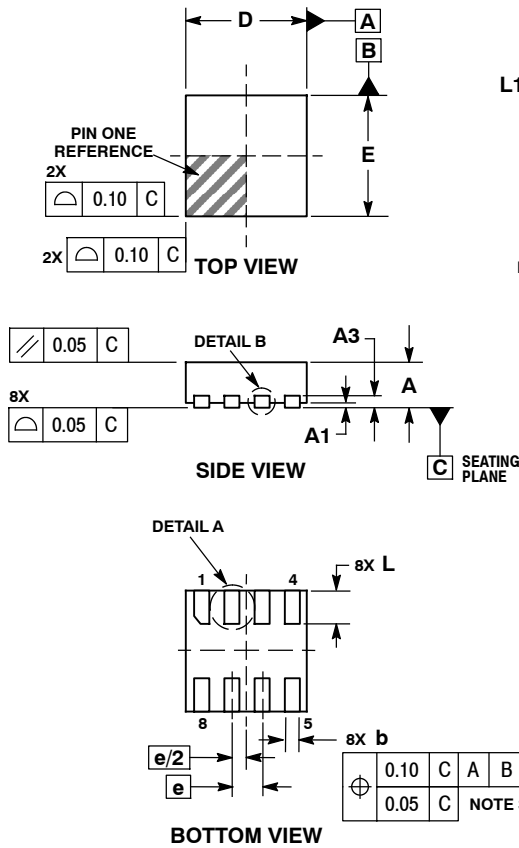

NOTES:

1. DIMENSIONING AND TOLERANCING PER ASME Y14.5M, 1994.
2. CONTROLLING DIMENSION: MILLIMETERS.
3. DIMENSION b APPLIES TO PLATED TERMINAL AND IS MEASURED BETWEEN 0.15 AND 0.30mm FROM TERMINAL.

DIM	MILLIMETERS	
	MIN	MAX
A	0.70	0.80
A1	0.00	0.05
A3	0.20 REF	
b	0.20	0.30
D	2.00 BSC	
E	2.00 BSC	
e	0.50 BSC	
L	0.50	0.60
L1	---	0.15

RECOMMENDED SOLDERING FOOTPRINT*

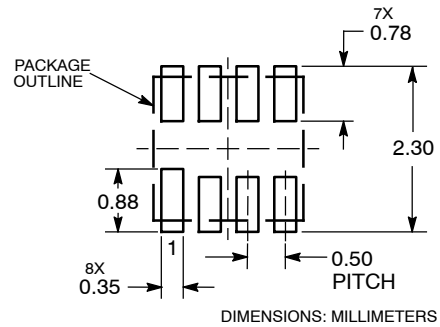

*For additional information on our Pb-Free strategy and soldering details, please download the ON Semiconductor Soldering and Mounting Techniques Reference Manual, SOLDERRM/D.

Timing-Safe is a trademark of Semiconductor Components Industries, LLC (SCILLC).

ON Semiconductor and are registered trademarks of Semiconductor Components Industries, LLC (SCILLC). SCILLC reserves the right to make changes without further notice to any products herein. SCILLC makes no warranty, representation or guarantee regarding the suitability of its products for any particular purpose, nor does SCILLC assume any liability arising out of the application or use of any product or circuit, and specifically disclaims any and all liability, including without limitation special, consequential or incidental damages. "Typical" parameters which may be provided in SCILLC data sheets and/or specifications can and do vary in different applications and actual performance may vary over time. All operating parameters, including "Typicals" must be validated for each customer application by customer's technical experts. SCILLC does not convey any license under its patent rights nor the rights of others. SCILLC products are not designed, intended, or authorized for use as components in systems intended for surgical implant into the body, or other applications intended to support or sustain life, or for any other application in which the failure of the SCILLC product could create a situation where personal injury or death may occur. Should Buyer purchase or use SCILLC products for any such unintended or unauthorized application, Buyer shall indemnify and hold SCILLC and its officers, employees, subsidiaries, affiliates, and distributors harmless against all claims, costs, damages, and expenses, and reasonable attorney fees arising out of, directly or indirectly, any claim of personal injury or death associated with such unintended or unauthorized use, even if such claim alleges that SCILLC was negligent regarding the design or manufacture of the part. SCILLC is an Equal Opportunity/Affirmative Action Employer. This literature is subject to all applicable copyright laws and is not for resale in any manner.

PUBLICATION ORDERING INFORMATION

LITERATURE FULFILLMENT:
Literature Distribution Center for ON Semiconductor
P.O. Box 5163, Denver, Colorado 80217 USA
Phone: 303-675-2175 or 800-344-3860 Toll Free USA/Canada
Fax: 303-675-2176 or 800-344-3867 Toll Free USA/Canada
Email: orderlit@onsemi.com

N. American Technical Support: 800-282-9855 Toll Free
USA/Canada
Europe, Middle East and Africa Technical Support:
Phone: 421 33 790 2910
Japan Customer Focus Center
Phone: 81-3-5773-3850

ON Semiconductor Website: www.onsemi.com
Order Literature: <http://www.onsemi.com/orderlit>

For additional information, please contact your local Sales Representative

Looking for pricing, stock, or lifecycle information?

Click below to explore more details on WIN SOURCE:

 [View PCS3P8504AG](#) on WIN SOURCE

 [ON Semiconductor](#) Information

Optimize Your Supply Chain with WIN SOURCE Solutions

-  Global Sourcing Solution
-  Obsolete Management
-  Cost Control Management
-  Shortage Management
-  Alternative Solution
-  Excess Inventory Management