



**THE DATASHEET OF
PCS3P2537AG-08-CR**





Peak EMI Reduction IC

Features

- 1x Peak EMI Reduction IC
- Input Frequency: 18MHz-36MHz
- Output Frequency: 18MHz-36MHz
- Frequency Deviation @ 27MHz: -0.25%
- Modulation Rate @ 27MHz: 30.1KHz
- Supply Voltage: 3.3V \pm 0.3V
- Operating current less than 8mA @ 27MHz
- Spread Spectrum Enable Control
- CMOS design
- 8L-WDFN (8L-TDFN) package

Product Description

PCS3P2537A is a 1x spread spectrum frequency modulator designed to reduce electromagnetic interference (EMI) at the clock source, allowing system wide reduction of EMI of down stream clock and data dependent signals. The device allows significant system cost savings by reducing the number of circuit board layers, ferrite beads and shielding and other passive components that are traditionally required to pass EMI regulations.

PCS3P2537A modulates the output of a single PLL in order to “spread” the bandwidth of a synthesized clock, and more importantly, decreases the peak amplitudes of its harmonics. This result in significantly lower system EMI compared to the typical narrow band signal produced by oscillators and most frequency generators. Lowering EMI by increasing a signal’s bandwidth is called ‘spread spectrum clock generation.’

PCS3P2537A has a frequency range of 18MHz-36MHz, and accepts input clock either from a Crystal or from an external reference and locks on to it delivering a 1x spread spectrum clock output. It has an SSON control for enabling and disabling Spread Spectrum function.

PCS3P2537A operates with a supply voltage of 3.3V, and is available in 8 L-WDFN package.

Application

PCS3P2537A is targeted towards PC peripheral devices and embedded systems.

Block Diagram

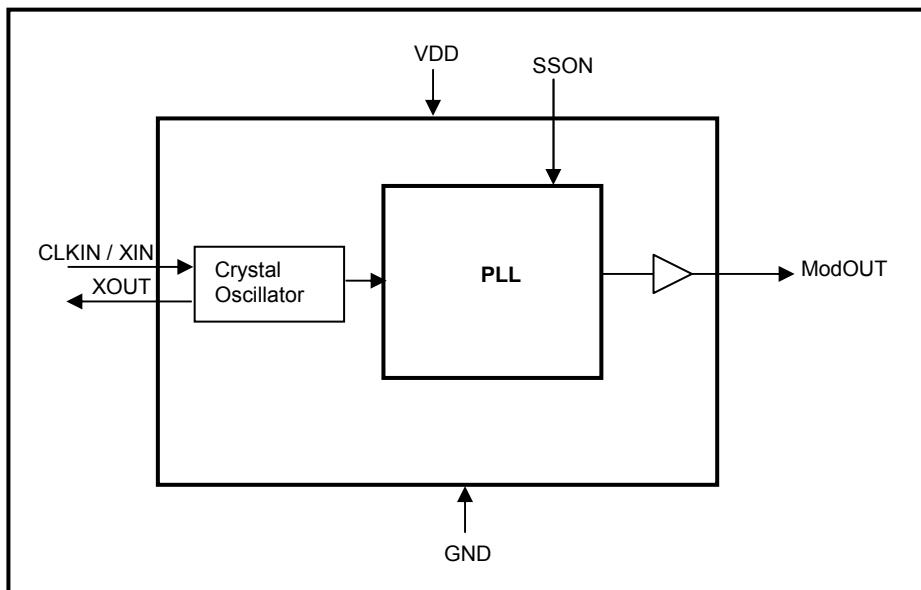

Pin Configuration (8L-WDFN Package)

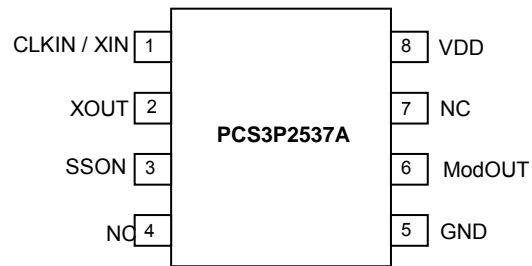

Pin Description

Pin#	Pin Name	Type	Description
1	CLKIN / XIN	I	External reference Clock input or Crystal connection. This pin has dual functions. It can be connected either to an external crystal or an external reference clock.
2	XOUT	O	Crystal connection. If using an external reference, this pin must be left unconnected.
3	SSON	I	When SSON is HIGH, the spread spectrum is enabled and when LOW, it turns off the spread spectrum.
4	NC		No Connect.
5	GND	P	Ground connection.
6	ModOUT	O	Spread Spectrum Clock Output.
7	NC		No Connect.
8	VDD	P	Power supply for the entire chip.

Absolute Maximum Ratings

Symbol	Parameter	Rating	Unit
VDD, VIN	Voltage on any pin with respect to Ground	-0.5 to +4.6	V
T _{STG}	Storage temperature	-65 to +125	°C
T _s	Max. Soldering Temperature (10 sec)	260	°C
T _J	Junction Temperature	150	°C
T _{DV}	Static Discharge Voltage (As per JEDEC STD22- A114-B)	2	KV

Note: These are stress ratings only and are not implied for functional use. Exposure to absolute maximum ratings for prolonged periods of time may affect device reliability.

Operating Conditions

Parameter	Description	Min	Max	Unit
VDD	Supply Voltage	3.0	3.6	V
T _A	Operating Temperature (Ambient Temperature)	0	70	°C
C _L	Load Capacitance		15	pF
C _{IN}	Input Capacitance		7	pF

DC Electrical Characteristics for 3.3V Supply

Symbol	Parameter	Min	Typ	Max	Unit
V _{IL}	Input low voltage	VSS-0.3		0.8	V
V _{IH}	Input high voltage	2.0		VDD+0.3	V
I _{IL}	Input low current			-35	µA
I _{IH}	Input high current			35	µA
V _{OL}	Output low voltage (VDD = 3.3V, I _{OL} = 8mA)			0.4	V
V _{OH}	Output high voltage (VDD = 3.3V, I _{OH} = 8mA)	2.5			V
I _{DD}	Static supply current ¹			2.5	mA
I _{CC}	Dynamic supply current (3.3V, 27MHz and no load)		5	8	mA
VDD	Operating Voltage	3	3.3	3.6	V
t _{ON}	Power-up time (first locked cycle after power-up)			5	mS
Z _{OUT}	Output impedance		36		Ω

Note: 1. CLKIN is pulled to GND.

AC Electrical Characteristics for 3.3V Supply

Symbol	Parameter	Min	Typ	Max	Unit
CLKIN	Input frequency	18	27	36	MHz
ModOUT	Output frequency	18	27	36	MHz
f_d	Frequency Deviation @ 27MHz	-0.2	-0.25	-0.3	%
MR	Modulation Rate @ 27MHz	30		33	KHz
t_{LH}^1	Output rise time (measured from 20% to 80%)			2	nS
t_{HL}^1	Output fall time (measured at 80% to 20%)			1.5	nS
t_{JC}	Cycle-to-Cycle Jitter at 27MHz		±200	±300	pS
t_D	Output duty cycle	45	50	55	%

Note: 1. t_{LH} and t_{HL} are measured into a capacitive load of 15pF.

Typical Application Schematic

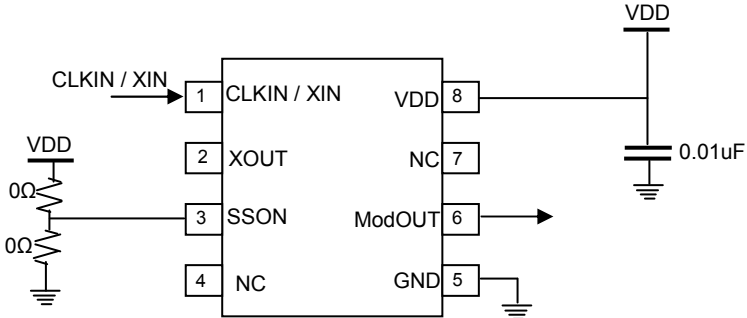

Note: Refer to Pin Description table for Functionality Details.

PCB Layout Recommendation

For optimum device performance, the following guidelines are recommended.

- Dedicated VDD and GND planes.
- The device must be isolated from system power supply noise. A 0.01µF decoupling capacitor should be mounted on the component side of the board as close to the VDD pin as possible. No vias should be

used between the decoupling capacitor and VDD pin. The PCB trace to VDD pin and the ground via should be kept as short as possible. All the VDD pins should have decoupling capacitors.

- In an optimum layout all components are on the same side of the board, minimizing vias through other signal layers.

A typical layout is shown in the figure

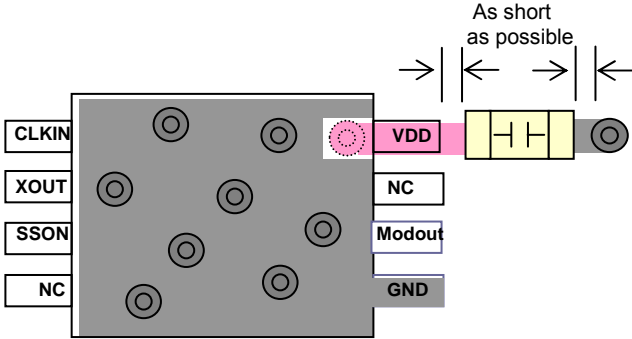

Package Information

8L-WDFN package

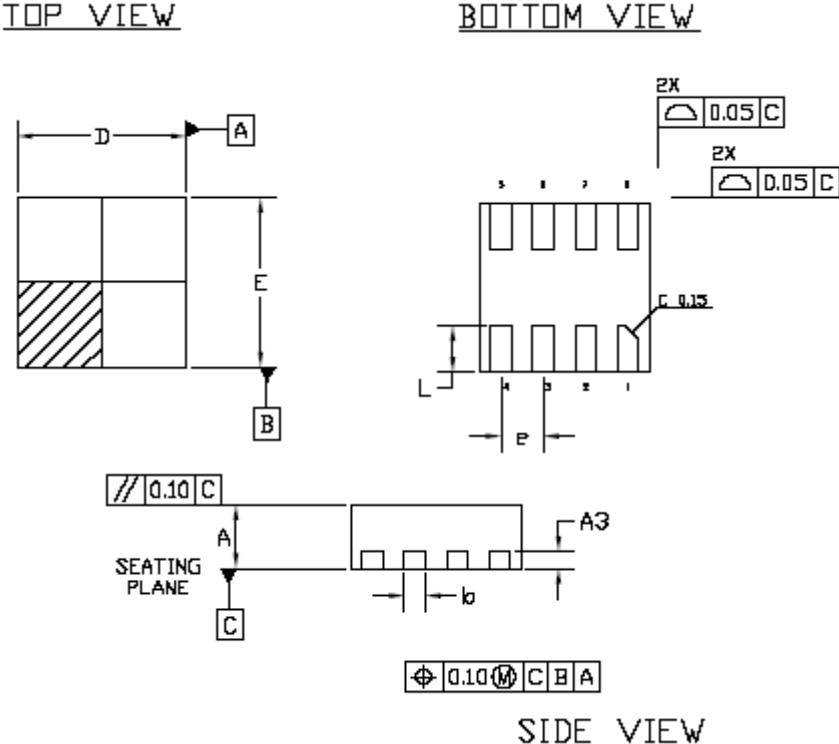

Symbol	Dimensions			
	Inches		Millimeters	
	Min	Max	Min	Max
A	0.027	0.0315	0.70	0.80
A3	0.008 BSC		0.203 BSC	
b	0.008	0.012	0.20	0.30
D	0.077	0.080	1.95	2.05
E	0.077	0.080	1.95	2.05
e	0.020 BSC		0.50 BSC	
L	0.020	0.024	0.50	0.60

Ordering Code

Part Number	Top Marking	Package	Temperature
PCS3P2537AG-08CR	AM	8L-WDFN (8L-TDFN) - TAPE & REEL, Green	0°C to +70°C

A "microdot" placed at the end of last row of marking or just below the last row toward the center of package indicates Pb-free.

ON Semiconductor and  are registered trademarks of Semiconductor Components Industries, LLC (SCILLC). SCILLC reserves the right to make changes without further notice to any products herein. SCILLC makes no warranty, representation or guarantee regarding the suitability of its products for any particular purpose, nor does SCILLC assume any liability arising out of the application or use of any product or circuit, and specifically disclaims any and all liability, including without limitation special, consequential or incidental damages. "Typical" parameters which may be provided in SCILLC data sheets and/or specifications can and do vary in different applications and actual performance may vary over time. All operating parameters, including "Typicals" must be validated for each customer application by customer's technical experts. SCILLC does not convey any license under its patent rights nor the rights of others. SCILLC products are not designed, intended, or authorized for use as components in systems intended for surgical implant into the body, or other applications intended to support or sustain life, or for any other application in which the failure of the SCILLC product could create a situation where personal injury or death may occur. Should Buyer purchase or use SCILLC products for any such unintended or unauthorized application, Buyer shall indemnify and hold SCILLC and its officers, employees, subsidiaries, affiliates, and distributors harmless against all claims, costs, damages, and expenses, and reasonable attorney fees arising out of, directly or indirectly, any claim of personal injury or death associated with such unintended or unauthorized use, even if such claim alleges that SCILLC was negligent regarding the design or manufacture of the part. SCILLC is an Equal Opportunity/Affirmative Action Employer. U.S Patent Pending; Timing-Safe and Active Bead are trademarks of PulseCore Semiconductor, a wholly owned subsidiary of ON Semiconductor. This literature is subject to all applicable copyright laws and is not for resale in any manner.

PUBLICATION ORDERING INFORMATION

LITERATURE FULFILLMENT:

Literature Distribution Center for ON Semiconductor
P.O. Box 5163, Denver, Colorado 80217 USA
Phone: 303-675-2175 or 800-344-3860 Toll Free USA/Canada
Fax: 303-675-2176 or 800-344-3867 Toll Free USA/Canada
Email: orderlit@onsemi.com

N. American Technical Support: 800-282-9855
Toll Free USA/Canada
Europe, Middle East and Africa Technical Support:
Phone: 421 33 790 2910
Japan Customer Focus Center
Phone: 81-3-5773-3850

ON Semiconductor Website:
www.onsemi.com

Order Literature: <http://www.onsemi.com/orderlit>

For additional information, please contact your local Sales Representative

Looking for pricing, stock, or lifecycle information?

Click below to explore more details on WIN SOURCE:

 [View PCS3P2537AG-08-CR on WIN SOURCE](#)

 [Pericom Information](#)

Optimize Your Supply Chain with WIN SOURCE Solutions

-  Global Sourcing Solution
-  Obsolete Management
-  Cost Control Management
-  Shortage Management
-  Alternative Solution
-  Excess Inventory Management