



# THE DATASHEET OF PCM2904DB





## STEREO AUDIO CODEC WITH USB INTERFACE, SINGLE-ENDED ANALOG INPUT/OUTPUT AND S/PDIF

### FEATURES

- PCM2904: Without S/PDIF
- PCM2906: With S/PDIF
- On-Chip USB Interface:
  - With Full-Speed Transceivers
  - Fully Compliant With USB 1.1 Specification
  - Certified by USB-IF
  - Partially Programmable Descriptors <sup>(1)</sup>
  - USB Adaptive Mode for Playback
  - USB Asynchronous Mode for Record
  - Bus Powered
- 16-Bit Delta-Sigma ADC and DAC
- Sampling Rate:
  - DAC: 32, 44.1, 48 kHz
  - ADC: 8, 11.025, 16, 22.05, 32, 44.1, 48 kHz
- On-Chip Clock Generator With Single 12-MHz Clock Source
- Single Power Supply: 5 V Typical ( $V_{BUS}$ )
- Stereo ADC
  - Analog Performance at  $V_{BUS} = 5$  V
    - THD+N = 0.01%
    - SNR = 89 dB
    - Dynamic Range = 89 dB
  - Decimation Digital Filter
    - Pass-Band Ripple =  $\pm 0.05$  dB
    - Stop-Band Attenuation =  $-65$  dB
  - Single-Ended Voltage Input
  - Antialiasing Filter Included
  - Digital LCF Included
- Stereo DAC:
  - Analog Performance at  $V_{BUS} = 5$  V
    - THD+N = 0.005%
    - SNR = 96 dB
    - Dynamic Range = 93 dB
  - Oversampling Digital Filter

(1) The descriptor can be modified by changing a mask.

- Pass-Band Ripple =  $\pm 0.1$  dB
- Stop-Band Attenuation =  $-43$  dB
- Single-Ended Voltage Output
- Analog LPF Included
- Multifunctions:
  - Human Interface Device (HID) Volume  $\pm$  Control and Mute Control
  - Suspend Flag
- Package: 28-Pin SSOP

### APPLICATIONS

- USB Audio Speaker
- USB Headset
- USB Monitor
- USB Audio Interface Box

### DESCRIPTION

The PCM2904/2906 is Texas Instruments single-chip USB stereo audio codec with USB-compliant full-speed protocol controller and S/PDIF (PCM2906 only). The USB protocol controller works with no software code, but the USB descriptors can be modified in some areas (for example, vendor ID/product ID). The PCM2904/2906 employs SpAct™ architecture, TI's unique system that recovers the audio clock from USB packet data. On-chip analog PLLs with SpAct enable playback and record with low clock jitter and with independent playback and record sampling rates.



Please be aware that an important notice concerning availability, standard warranty, and use in critical applications of Texas Instruments semiconductor products and disclaimers thereto appears at the end of this data sheet.

SpAct is a trademark of Texas Instruments.

System Two, Audio Precision are trademarks of Audio Precision, Inc.



This integrated circuit can be damaged by ESD. Texas Instruments recommends that all integrated circuits be handled with appropriate precautions. Failure to observe proper handling and installation procedures can cause damage.

ESD damage can range from subtle performance degradation to complete device failure. Precision integrated circuits may be more susceptible to damage because very small parametric changes could cause the device not to meet its published specifications.

### PACKAGING ORDERING INFORMATION

PRODUCT	PACKAGE-LEAD	PACKAGE DESIGNATOR	SPECIFIED TEMPERATURE RANGE	PACKAGE MARKING	ORDERING NUMBER	TRANSPORT MEDIA
PCM2904DB	28-lead SSOP	28DB	–25°C to 85°C	PCM2904	PCM2904DB	Rails
					PCM2904DBR	Tape and reel
PCM2906DB	28-lead SSOP	28DB	–25°C to 85°C	PCM2906	PCM2906DB	Rails
					PCM2906DBR	Tape and reel

### ABSOLUTE MAXIMUM RATINGS

over operating free-air temperature range (unless otherwise noted)<sup>(1)</sup>

		PCM2904/PCM2906	UNIT
Supply voltage, $V_{BUS}$		–0.3 to 6.5	V
Ground voltage differences, AGNDC, AGNDP, AGNDX, DGND, DGNDU		±0.1	V
Digital input voltage	SEL0, SEL1, TEST0 (DIN) <sup>(2)</sup>	–0.3 to 6.5	V
	D+, D–, HID0, HID1, HID2, XTI, XTO, TEST1 (DOUT) <sup>(2)</sup> , $\overline{SSPND}$	–0.3 to $(V_{DDI} + 0.3) < 4$	
Analog input voltage	$V_{INL}$ , $V_{INR}$ , $V_{COM}$ , $V_{OUTR}$ , $V_{OUTL}$	–0.3 to $(V_{CCCI} + 0.3) < 4$	V
	$V_{CCCI}$ , $V_{CCP1I}$ , $V_{CCP2I}$ , $V_{CCXI}$ , $V_{DDI}$	–0.3 to 4	
Input current (any pins except supplies)		±10	mA
Ambient temperature under bias		–40 to 125	°C
Storage temperature, $T_{stg}$		–55 to 150	°C
Junction temperature, $T_J$		150	°C
Lead temperature (soldering)		260	°C, 5 s
Package temperature (IR reflow, peak)		250	°C

(1) Stresses beyond those listed under *absolute maximum ratings* may cause permanent damage to the device. These are stress ratings only, and functional operation of the device at these or any other conditions beyond those indicated under *recommended operating conditions* is not implied. Exposure to absolute-maximum-rated conditions for extended periods may affect device reliability.

(2) ( ): PCM2906

## ELECTRICAL CHARACTERISTICS

All specifications at  $T_A = 25^\circ\text{C}$ ,  $V_{\text{BUS}} = 5\text{ V}$ ,  $f_s = 44.1\text{ kHz}$ ,  $f_{\text{IN}} = 1\text{ kHz}$ , 16-bit data (unless otherwise noted)

PARAMETER		TEST CONDITIONS	PCM2904DB, PCM2906DB			UNIT	
			MIN	TYP	MAX		
<b>DIGITAL INPUT/OUTPUT</b>							
Host interface		Apply USB Revision 1.1, full speed					
Audio data format		USB isochronous data format					
<b>INPUT LOGIC</b>							
$V_{\text{IH}}^{(1)}$	Input logic level		2		3.3	Vdc	
$V_{\text{IL}}^{(1)}$					0.8		
$V_{\text{IH}}^{(2)(3)}$			2.52				3.3
$V_{\text{IL}}^{(2)(3)}$							0.9
$V_{\text{IH}}^{(4)}$				2			5.25
$V_{\text{IL}}^{(4)}$							0.8
$V_{\text{IH}}^{(5)}$				2.52			5.25
$V_{\text{IL}}^{(5)}$							0.9
$I_{\text{IH}}^{(1)(2)(4)}$	Input logic current	$V_{\text{IN}} = 3.3\text{ V}$				$\pm 10$	
$I_{\text{IL}}^{(1)(2)(4)}$		$V_{\text{IN}} = 0\text{ V}$					$\pm 10$
$I_{\text{IH}}^{(3)}$		$V_{\text{IN}} = 3.3\text{ V}$		50		80	$\mu\text{A}$
$I_{\text{IL}}^{(3)}$		$V_{\text{IN}} = 0\text{ V}$				$\pm 10$	
$I_{\text{IH}}^{(5)}$		$V_{\text{IN}} = 3.3\text{ V}$		65		100	
$I_{\text{IL}}^{(5)}$		$V_{\text{IN}} = 0\text{ V}$				$\pm 10$	
<b>OUTPUT LOGIC</b>							
$V_{\text{OH}}^{(1)}$	Output logic level		2.8			Vdc	
$V_{\text{OL}}^{(1)}$							0.3
$V_{\text{OH}}^{(6)}$		$I_{\text{OH}} = -4\text{ mA}$		2.8			
$V_{\text{OL}}^{(6)}$		$I_{\text{OL}} = 4\text{ mA}$					0.5
$V_{\text{OH}}^{(7)}$		$I_{\text{OH}} = -2\text{ mA}$		2.8			
$V_{\text{OL}}^{(7)}$		$I_{\text{OL}} = 2\text{ mA}$					0.5
<b>CLOCK FREQUENCY</b>							
Input clock frequency, XTI			11.994	12	12.006	MHz	
<b>ADC CHARACTERISTICS</b>							
Resolution			8, 16			bits	
Audio data channel			1, 2			channel	
<b>CLOCK FREQUENCY</b>							
$f_s$	Sampling frequency		8, 11.025, 16, 22.05, 32, 44.1, 48			kHz	
<b>DC ACCURACY</b>							
Gain mismatch, channel-to-channel			$\pm 1$	$\pm 5$		% of FSR	
Gain error			$\pm 2$	$\pm 10$		% of FSR	
Bipolar zero error			$\pm 0$			% of FSR	

- (1) Pins 1, 2: D+, D–  
(2) Pin 21: XTI  
(3) Pins 5, 6, 7: HID0, HID1, HID2  
(4) Pins 8, 9: SEL0, SEL1  
(5) Pin 24: DIN  
(6) Pin 25: DOUT  
(7) Pin 28:  $\overline{\text{SSPND}}$

## ELECTRICAL CHARACTERISTICS (Continued)

All specifications at  $T_A = 25^\circ\text{C}$ ,  $V_{\text{BUS}} = 5\text{ V}$ ,  $f_s = 44.1\text{ kHz}$ ,  $f_{\text{IN}} = 1\text{ kHz}$ , 16-bit data (unless otherwise noted)

PARAMETER		TEST CONDITIONS	PCM2904DB, PCM2906DB			UNIT
			MIN	TYP	MAX	
<b>DYNAMIC PERFORMANCE<sup>(1)</sup></b>						
THD+N	Total harmonic distortion plus noise	$V_{\text{IN}} = -0.5\text{ dB}^{(2)}$ , $V_{\text{CCCI}} = 3.67\text{ V}$		0.01%	0.02%	
		$V_{\text{IN}} = -0.5\text{ dB}^{(3)}$		0.1%		
		$V_{\text{IN}} = -60\text{ dB}$		5%		
	Dynamic range	A-weighted	81	89		dB
	S/N ratio	A-weighted	81	89		dB
	Channel separation		80	85		dB
<b>ANALOG INPUT</b>						
	Input voltage			$0.6 V_{\text{CCCI}}$		Vp-p
	Center voltage			$0.5 V_{\text{CCCI}}$		V
	Input impedance			30		k $\Omega$
	Antialiasing filter frequency response	-3 dB		150		kHz
		$f_{\text{IN}} = 20\text{ kHz}$		-0.08		dB
<b>DIGITAL FILTER PERFORMANCE</b>						
	Pass band				$0.454 f_s$	Hz
	Stop band		$0.583 f_s$			Hz
	Pass-band ripple				$\pm 0.05$	dB
	Stop-band attenuation		-65			dB
$t_d$	Delay time			$17.4/f_s$		s
	LCF frequency response	-3 dB		$0.078 f_s$		MHz
<b>DAC CHARACTERISTICS</b>						
	Resolution			8, 16		bits
	Audio data channel			1, 2		channel
<b>CLOCK FREQUENCY</b>						
$f_s$	Sampling frequency			32, 44.1, 48		kHz
<b>DC ACCURACY</b>						
	Gain mismatch, channel-to-channel			$\pm 1$	$\pm 5$	% of FSR
	Gain error			$\pm 2$	$\pm 10$	% of FSR
	Bipolar zero error			$\pm 2$		% of FSR
<b>DYNAMIC PERFORMANCE<sup>(4)</sup></b>						
THD+N	Total harmonic distortion plus noise	$V_{\text{OUT}} = 0\text{ dB}$		0.005%	0.016%	
		$V_{\text{OUT}} = -60\text{ dB}$		3%		
	Dynamic range	EIAJ, A-weighted	87	93		dB
SNR	Signal-to-noise ratio	EIAJ, A-weighted	90	96		dB
	Channel separation		86	92		dB

(1)  $f_{\text{IN}} = 1\text{ kHz}$ , using the System Two™ audio measurement system by Audio Precision™ in RMS mode with 20-kHz LPF, 400-Hz HPF in calculation.

(2) Using external voltage regulator for  $V_{\text{CCCI}}$  (as shown in Figure 36 and Figure 37, using REG103xA-A)

(3) Using internal voltage regulator for  $V_{\text{CCCI}}$  (as shown in Figure 38 and Figure 39)

(4)  $f_{\text{OUT}} = 1\text{ kHz}$ , using the System Two audio measurement system by Audio Precision in RMS mode with 20-kHz LPF, 400-Hz HPF.

## ELECTRICAL CHARACTERISTICS (Continued)

All specifications at  $T_A = 25^\circ\text{C}$ ,  $V_{\text{BUS}} = 5\text{ V}$ ,  $f_s = 44.1\text{ kHz}$ ,  $f_{\text{IN}} = 1\text{ kHz}$ , 16-bit data (unless otherwise noted)

PARAMETER		TEST CONDITIONS	PCM2904DB, PCM2906DB			UNIT	
			MIN	TYP	MAX		
<b>ANALOG OUTPUT</b>							
$V_O$	Output voltage		0.6 $V_{\text{CCCI}}$			Vp-p	
	Center voltage		0.5 $V_{\text{CCCI}}$			V	
	Load impedance	AC coupling	10			k $\Omega$	
	LPF frequency response	–3 dB	250			kHz	
		$f = 20\text{ kHz}$	–0.03			dB	
<b>DIGITAL FILTER PERFORMANCE</b>							
	Pass band		0.445 $f_s$			Hz	
	Stop band		0.555 $f_s$			Hz	
	Pass-band ripple		$\pm 0.1$			dB	
	Stop-band attenuation		–43			dB	
$t_d$	Delay time		14.3 $f_s$			s	
<b>POWER SUPPLY REQUIREMENTS</b>							
$V_{\text{BUS}}$	Voltage range		4.36	5	5.25	VDC	
	Supply current	ADC, DAC operation	56			mA	
		Suspend mode <sup>(1)</sup>	210			$\mu\text{A}$	
$P_D$	Power dissipation	ADC, DAC operation	280			mW	
		Suspend mode <sup>(1)</sup>	1.05				
	Internal power supply voltage <sup>(2)</sup>		3.25	3.35	3.5	VDC	
<b>TEMPERATURE RANGE</b>							
	Operating temperature		–25			85	$^\circ\text{C}$
$\theta_{\text{JA}}$	Thermal resistance	28-pin SSOP	100			$^\circ\text{C/W}$	

(1) In USB suspend state

(2) Pins 10, 17, 19, 23, 27:  $V_{\text{CCCI}}$ ,  $V_{\text{CCP11}}$ ,  $V_{\text{CCP21}}$ ,  $V_{\text{CCX1}}$ ,  $V_{\text{DD1}}$

## PIN ASSIGNMENTS

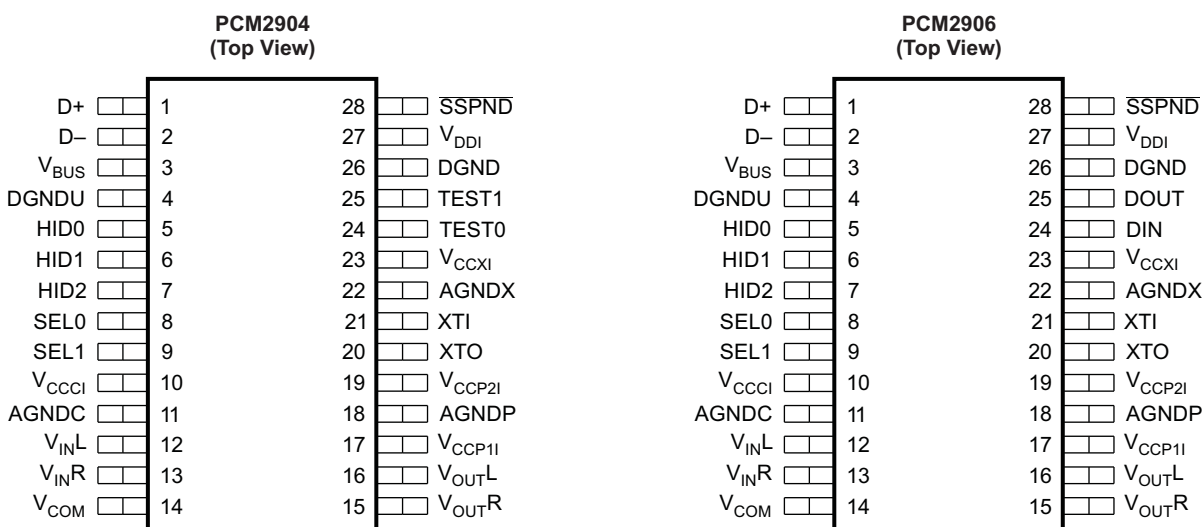

P0007-05

**Table 1. PCM2904 TERMINAL FUNCTIONS**

TERMINAL		I/O	DESCRIPTION
NAME	NO.		
AGNDC	11	–	Analog ground for codec
AGNDP	18	–	Analog ground for PLL
AGNDX	22	–	Analog ground for oscillator
D–	2	I/O	USB differential input/output minus <sup>(1)</sup>
D+	1	I/O	USB differential input/output plus <sup>(1)</sup>
DGND	26	–	Digital ground
DGNDU	4	–	Digital ground for USB transceiver
HID0	5	I	HID key state input (mute), active-high <sup>(2)</sup>
HID1	6	I	HID key state input (volume up), active-high <sup>(2)</sup>
HID2	7	I	HID key state input (volume down), active-high <sup>(2)</sup>
SEL0	8	I	Must be set to high <sup>(3)</sup>
SEL1	9	I	Must be set to high <sup>(3)</sup>
SSPND	28	O	Suspend flag, active-low (Low: suspend, High: operational)
TEST0	24	I	Test pin, must be connected to GND
TEST1	25	O	Test pin, must be left open
V <sub>BUS</sub>	3	–	Connect to USB power (V <sub>BUS</sub> )
V <sub>CCCI</sub>	10	–	Internal analog power supply for codec <sup>(4)</sup>
V <sub>CCP1I</sub>	17	–	Internal analog power supply for PLL <sup>(4)</sup>
V <sub>CCP2I</sub>	19	–	Internal analog power supply for PLL <sup>(4)</sup>
V <sub>CCXI</sub>	23	–	Internal analog power supply for oscillator <sup>(4)</sup>
V <sub>COM</sub>	14	–	Common for ADC/DAC (V <sub>CCCI</sub> /2) <sup>(4)</sup>
V <sub>DDI</sub>	27	–	Internal digital power supply <sup>(4)</sup>
V <sub>INL</sub>	12	I	ADC analog input for L-channel
V <sub>INR</sub>	13	I	ADC analog input for R-channel
V <sub>OUTL</sub>	16	O	DAC analog output for L-channel
V <sub>OUTR</sub>	15	O	DAC analog output for R-channel
XTI	21	I	Crystal oscillator input <sup>(5)</sup>
XTO	20	O	Crystal oscillator output

- (1) LV-TTL level
- (2) 3.3-V CMOS-level input with internal pulldown. This pin informs the PC of serviceable control signals such as mute, volume up, or volume down, which have no direct connection with the internal DAC or ADC. See the *Interface #3* and *End-Points* sections.
- (3) TTL Schmitt trigger, 5-V tolerant
- (4) Connect a decoupling capacitor to GND.
- (5) 3.3-V CMOS-level input

**Table 2. PCM2906 TERMINAL FUNCTIONS**

TERMINAL		I/O	DESCRIPTION
NAME	NO.		
AGNDC	11	–	Analog ground for codec
AGNDP	18	–	Analog ground for PLL
AGNDX	22	–	Analog ground for oscillator
D–	2	I/O	USB differential input/output minus <sup>(1)</sup>
D+	1	I/O	USB differential input/output plus <sup>(1)</sup>
DGND	26	–	Digital ground
DGNDU	4	–	Digital ground for USB transceiver
DIN	24	I	S/PDIF input <sup>(2)</sup>
DOUT	25	O	S/PDIF output
HID0	5	I	HID key state input (mute), active-high <sup>(3)</sup>
HID1	6	I	HID key state input (volume up), active-high <sup>(3)</sup>
HID2	7	I	HID key state input (volume down), active-high <sup>(3)</sup>
SEL0	8	I	Must be set to high <sup>(4)</sup>
SEL1	9	I	Must be set to high <sup>(4)</sup>
$\overline{\text{SSPND}}$	28	O	Suspend flag, active-low (Low: suspend, High: operational)
V <sub>BUS</sub>	3	–	Connect to USB power (V <sub>BUS</sub> )
V <sub>CCCI</sub>	10	–	Internal analog power supply for codec <sup>(5)</sup>
V <sub>CCP1I</sub>	17	–	Internal analog power supply for PLL <sup>(5)</sup>
V <sub>CCP2I</sub>	19	–	Internal analog power supply for PLL <sup>(5)</sup>
V <sub>CCXI</sub>	23	–	Internal analog power supply for oscillator <sup>(5)</sup>
V <sub>COM</sub>	14	–	Common for ADC/DAC (V <sub>CCCI</sub> /2) <sup>(5)</sup>
V <sub>DDI</sub>	27	–	Internal digital power supply <sup>(5)</sup>
V <sub>INL</sub>	12	I	ADC analog input for L-channel
V <sub>INR</sub>	13	I	ADC analog input for R-channel
V <sub>OUTL</sub>	16	O	DAC analog output for L-channel
V <sub>OUTR</sub>	15	O	DAC analog output for R-channel
XTI	21	I	Crystal oscillator input <sup>(6)</sup>
XTO	20	O	Crystal oscillator output

(1) LV-TTL level

(2) 3.3-V CMOS-level input with internal pulldown, 5-V tolerant

(3) 3.3-V CMOS-level input with internal pulldown. This pin informs the PC of serviceable control signals such as mute, volume up, or volume down, which have no direct connection with the internal DAC or ADC. See the *Interface #3* and *End-Points* sections.

(4) TTL Schmitt trigger, 5-V tolerant

(5) Connect a decoupling capacitor to GND.

(6) 3.3-V CMOS-level input

PCM2904 FUNCTIONAL BLOCK DIAGRAM

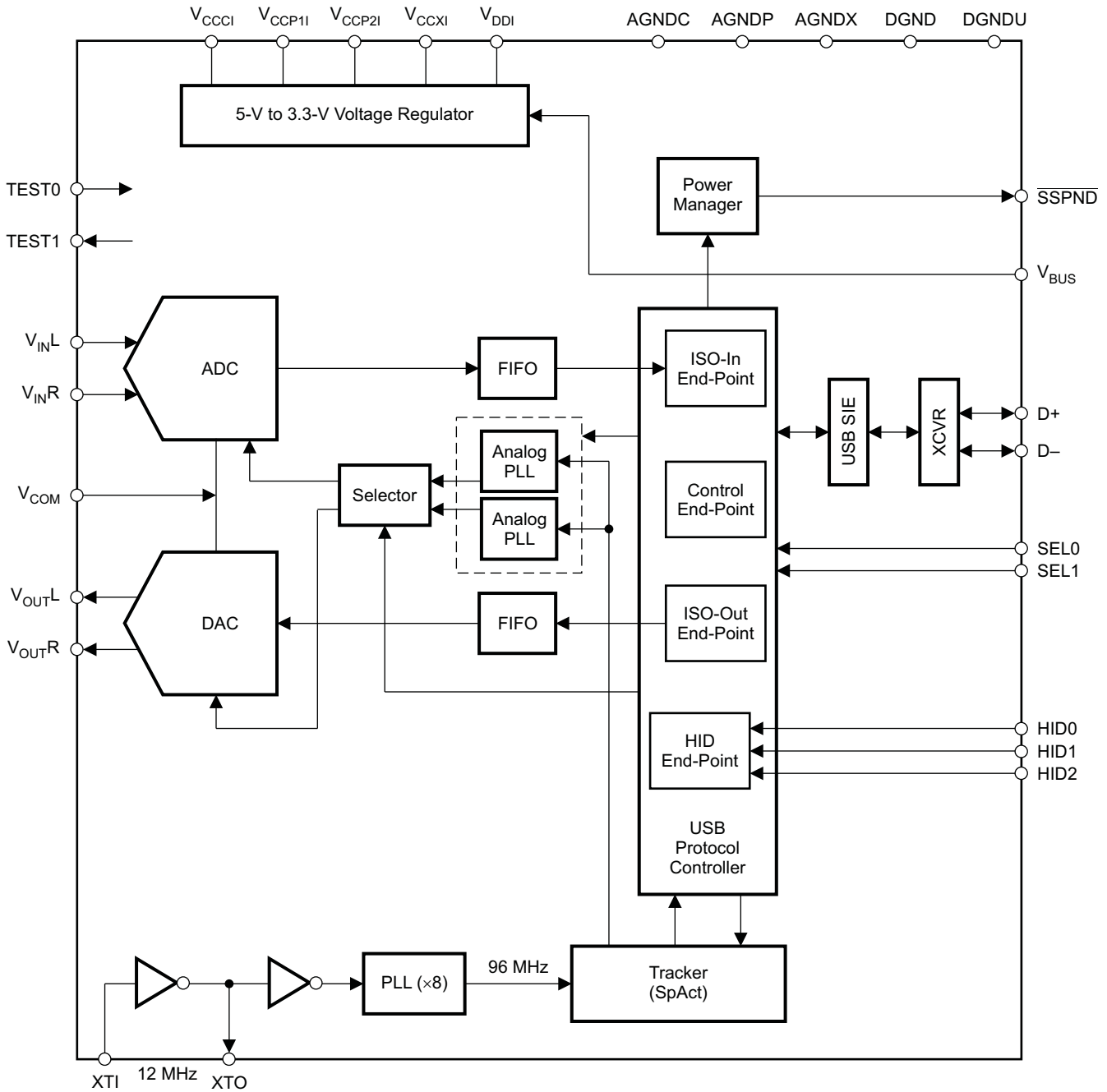

B0238-01

PCM2906 FUNCTIONAL BLOCK DIAGRAM

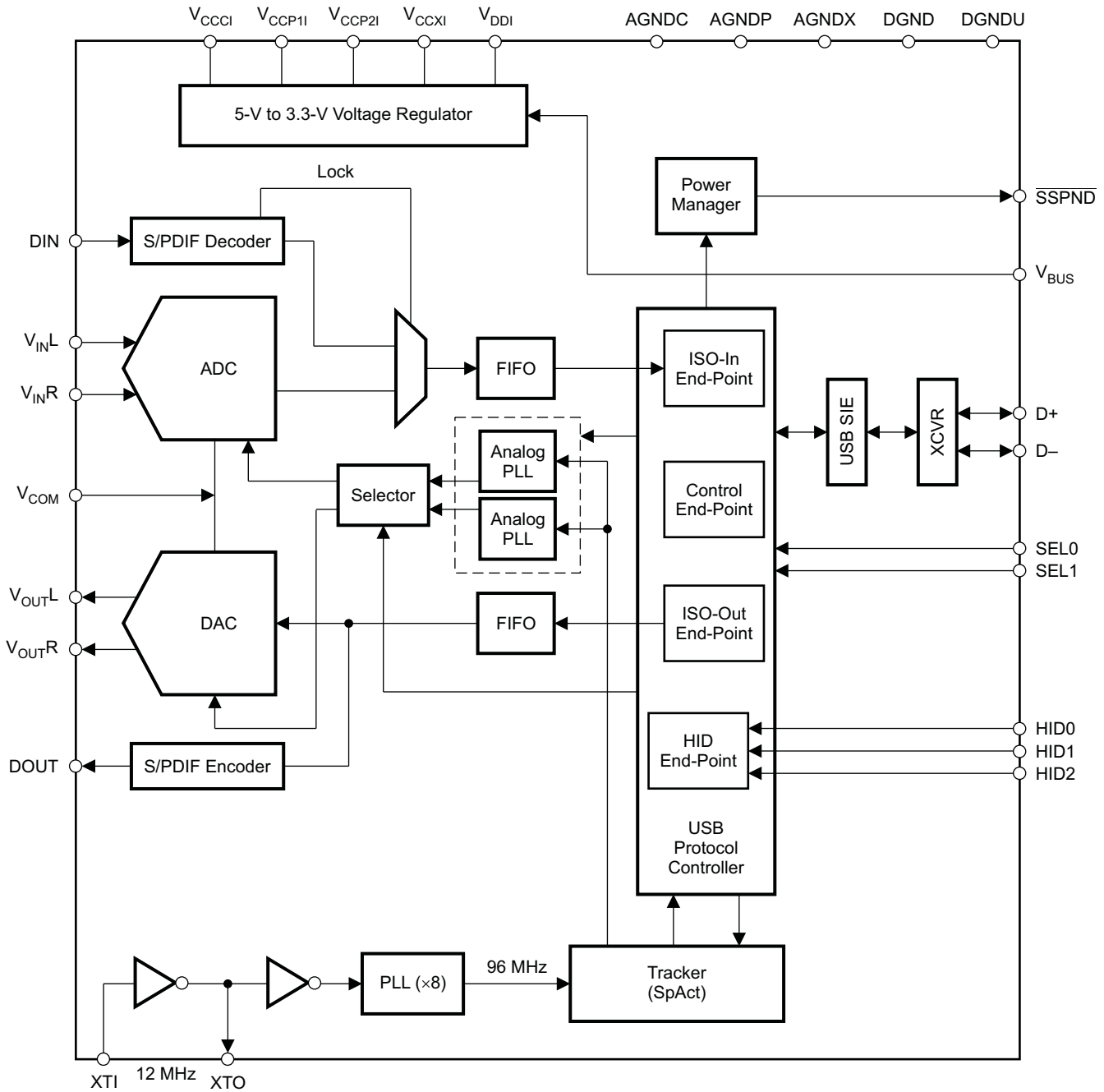

B0239-01

### BLOCK DIAGRAM OF ANALOG FRONT-END (RIGHT CHANNEL)

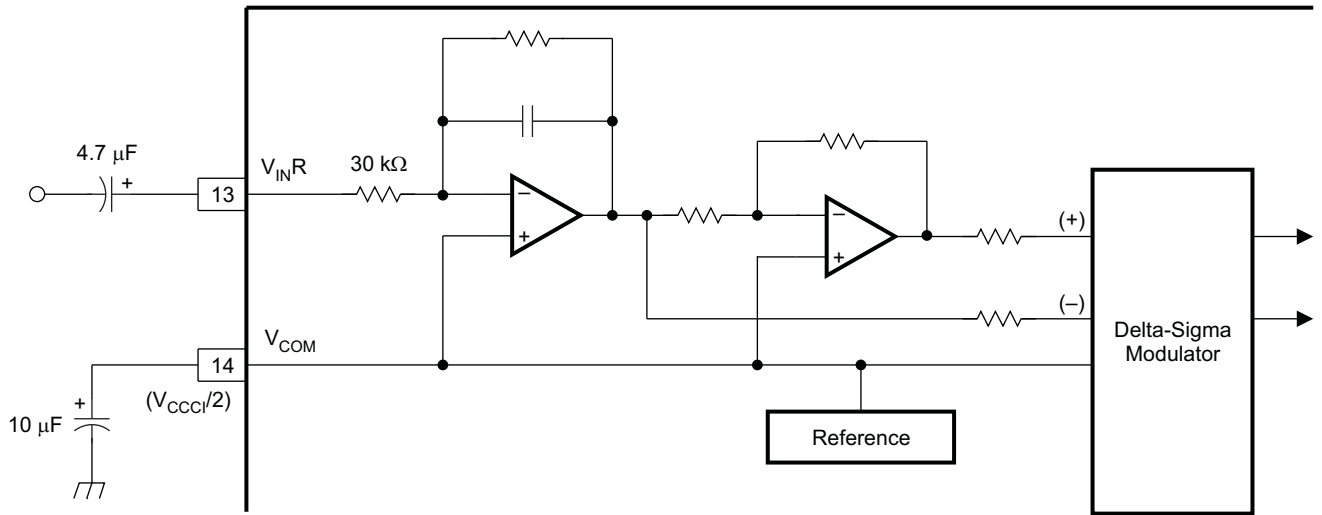

S0011-06

## TYPICAL CHARACTERISTICS

All specifications at  $T_A = 25^\circ\text{C}$ ,  $V_{\text{BUS}} = 5\text{ V}$ ,  $f_s = 44.1\text{ kHz}$ ,  $f_{\text{IN}} = 1\text{ kHz}$ , 16-bit data, using REG103xA-A, unless otherwise noted.

### ADC

TOTAL HARMONIC DISTORTION + NOISE  
vs  
FREE-AIR TEMPERATURE

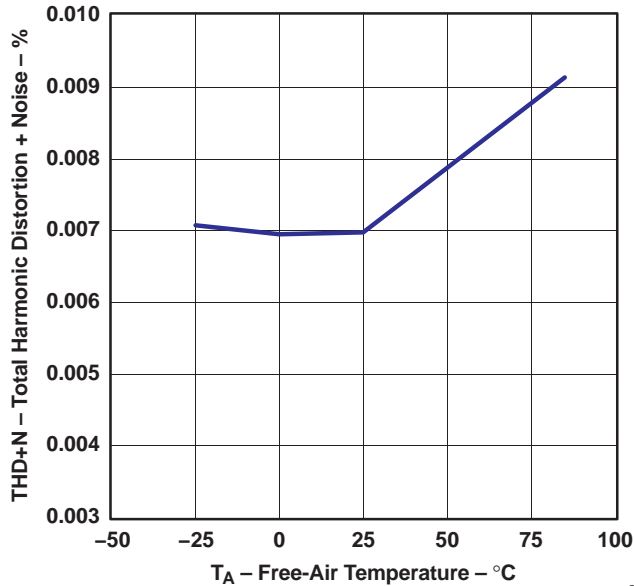

Figure 1. THD+N at  $-0.5\text{ dB}$  vs Temperature

DYNAMIC RANGE and SNR  
vs  
FREE-AIR TEMPERATURE

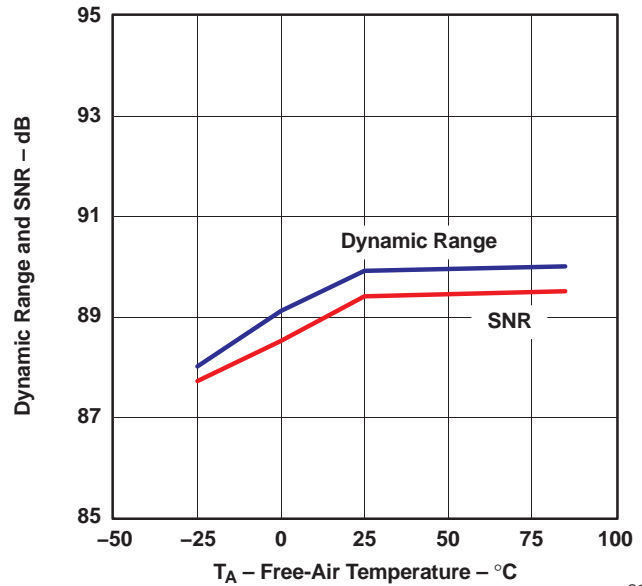

Figure 2.

TOTAL HARMONIC DISTORTION + NOISE  
vs  
SUPPLY VOLTAGE

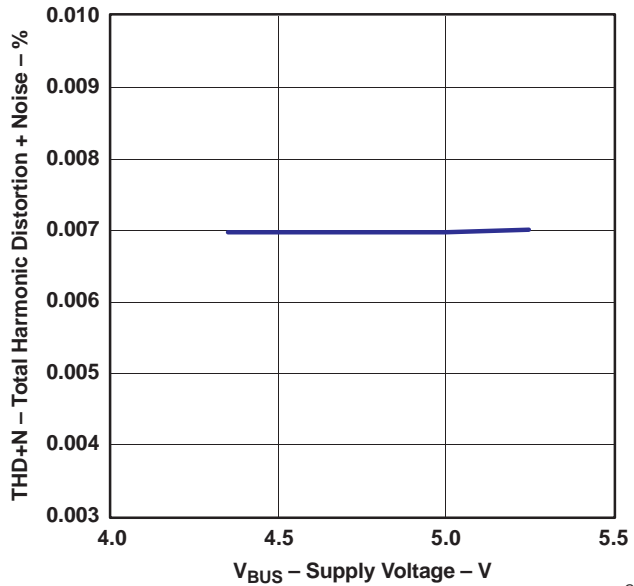

Figure 3. THD+N at  $-0.5\text{ dB}$  vs Supply Voltage

DYNAMIC RANGE and SNR  
vs  
SUPPLY VOLTAGE

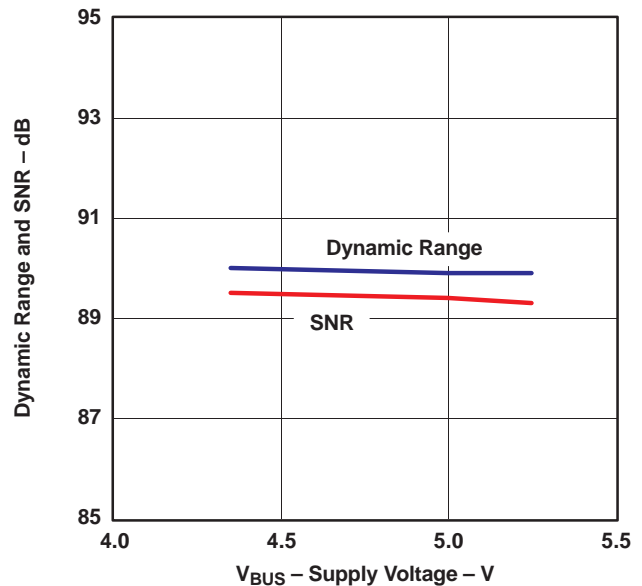

Figure 4.

**TYPICAL CHARACTERISTICS (continued)**

All specifications at  $T_A = 25^\circ\text{C}$ ,  $V_{\text{BUS}} = 5\text{ V}$ ,  $f_s = 44.1\text{ kHz}$ ,  $f_{\text{IN}} = 1\text{ kHz}$ , 16-bit data, using REG103xA-A, unless otherwise noted.

**TOTAL HARMONIC DISTORTION + NOISE  
vs  
SAMPLING FREQUENCY**

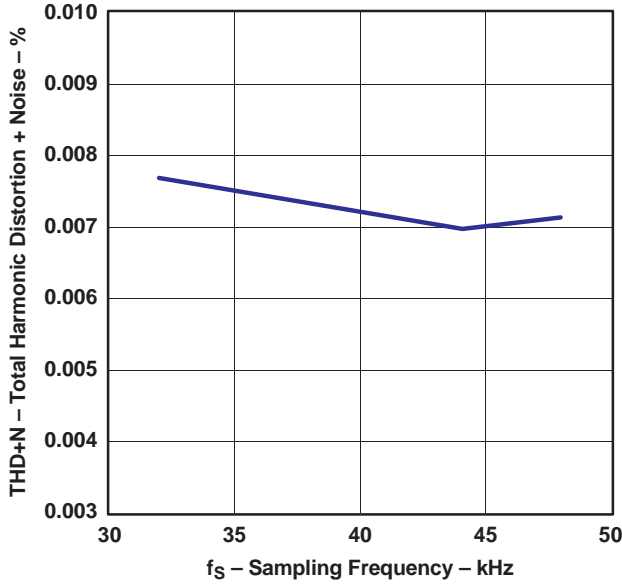

Figure 5. THD+N at -0.5 dB vs Sampling Frequency

**DYNAMIC RANGE and SNR  
vs  
SAMPLING FREQUENCY**

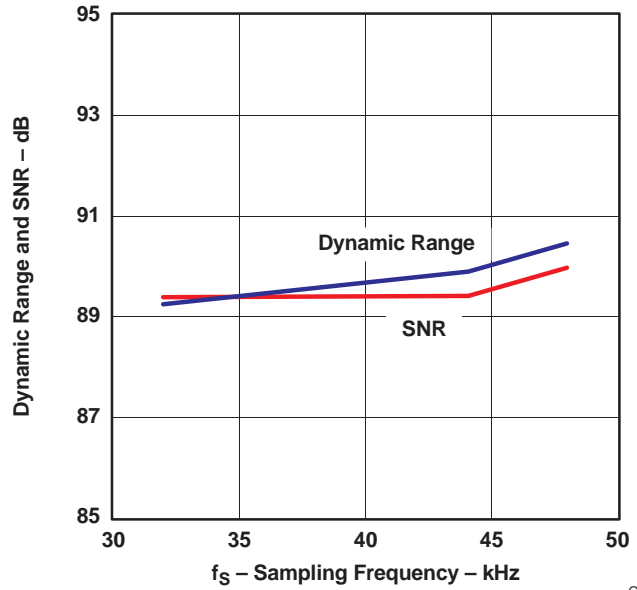

Figure 6.

**DAC**

**TOTAL HARMONIC DISTORTION + NOISE  
vs  
FREE-AIR TEMPERATURE**

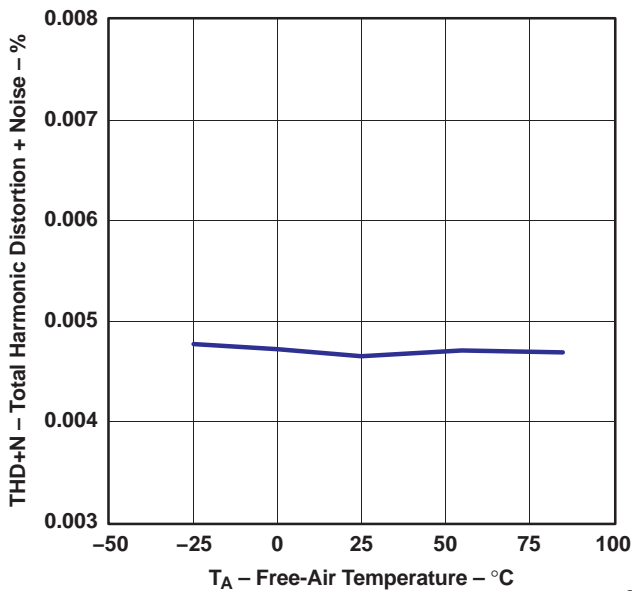

Figure 7. THD+N at 0 dB vs Temperature

**DYNAMIC RANGE and SNR  
vs  
FREE-AIR TEMPERATURE**

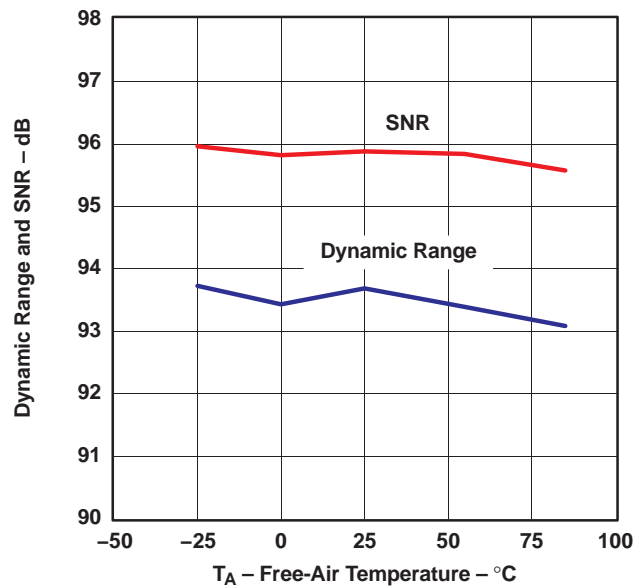

Figure 8.

### TYPICAL CHARACTERISTICS (continued)

All specifications at  $T_A = 25^\circ\text{C}$ ,  $V_{\text{BUS}} = 5\text{ V}$ ,  $f_s = 44.1\text{ kHz}$ ,  $f_{\text{IN}} = 1\text{ kHz}$ , 16-bit data, using REG103xA-A, unless otherwise noted.

**TOTAL HARMONIC DISTORTION + NOISE  
vs  
SUPPLY VOLTAGE**

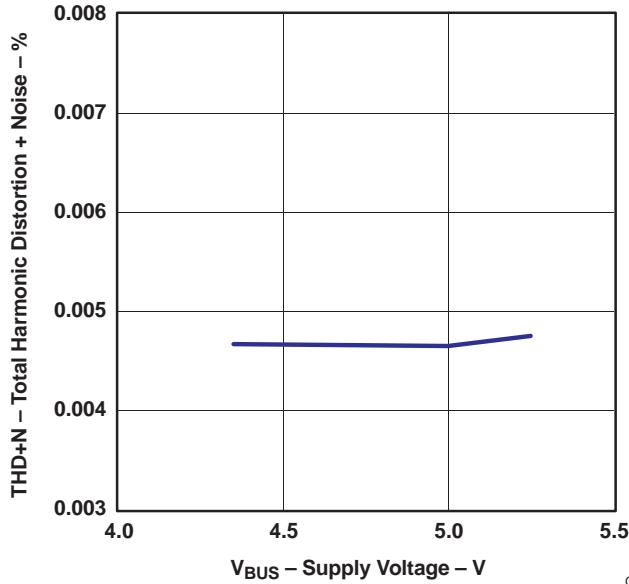

Figure 9. THD+N at 0 dB vs Supply Voltage

**DYNAMIC RANGE and SNR  
vs  
SUPPLY VOLTAGE**

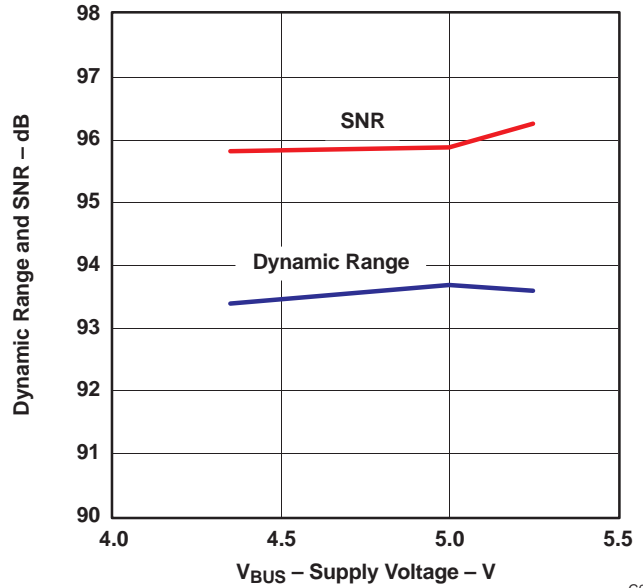

Figure 10.

**TOTAL HARMONIC DISTORTION + NOISE  
vs  
SAMPLING FREQUENCY**

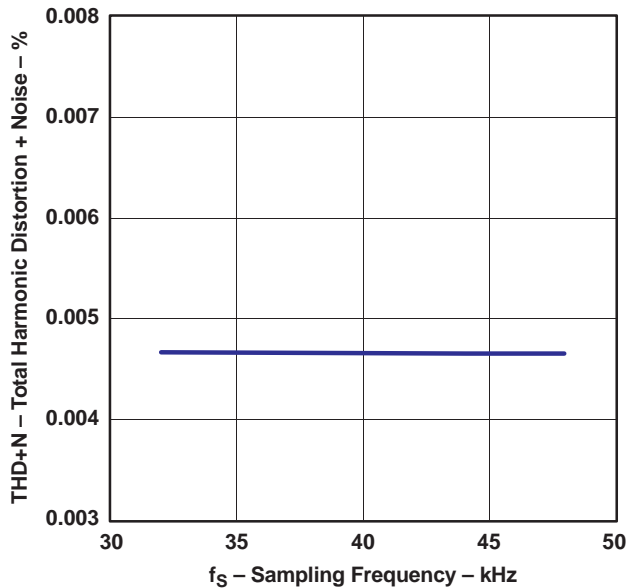

Figure 11. THD+N at 0 dB vs Sampling Frequency

**DYNAMIC RANGE and SNR  
vs  
SAMPLING FREQUENCY**

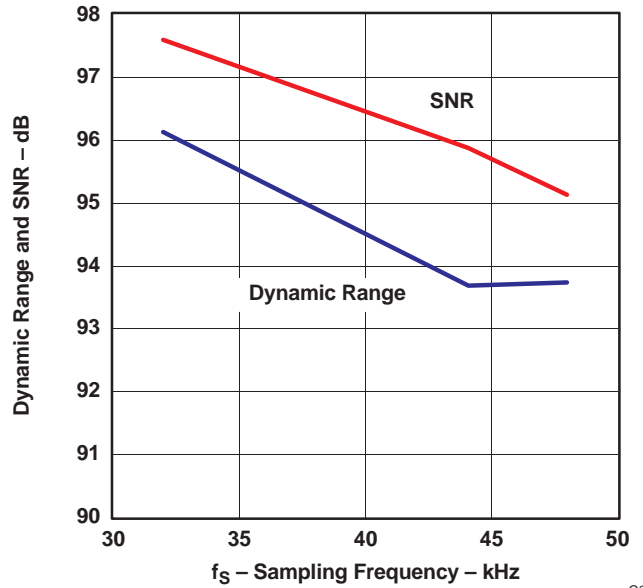

Figure 12.

**TYPICAL CHARACTERISTICS (continued)**

All specifications at  $T_A = 25^\circ\text{C}$ ,  $V_{\text{BUS}} = 5\text{ V}$ ,  $f_s = 44.1\text{ kHz}$ ,  $f_{\text{IN}} = 1\text{ kHz}$ , 16-bit data, using REG103xA-A, unless otherwise noted.

**SUPPLY CURRENT**

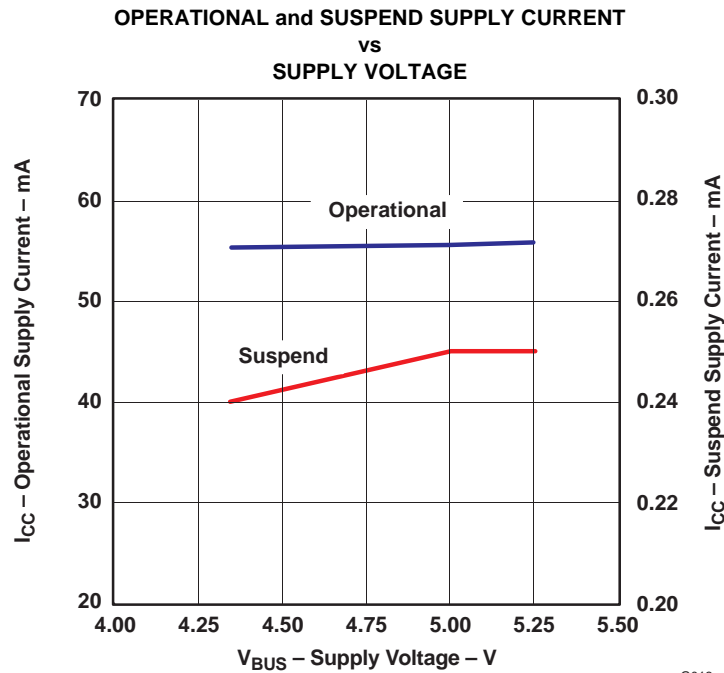

Figure 13.

G013

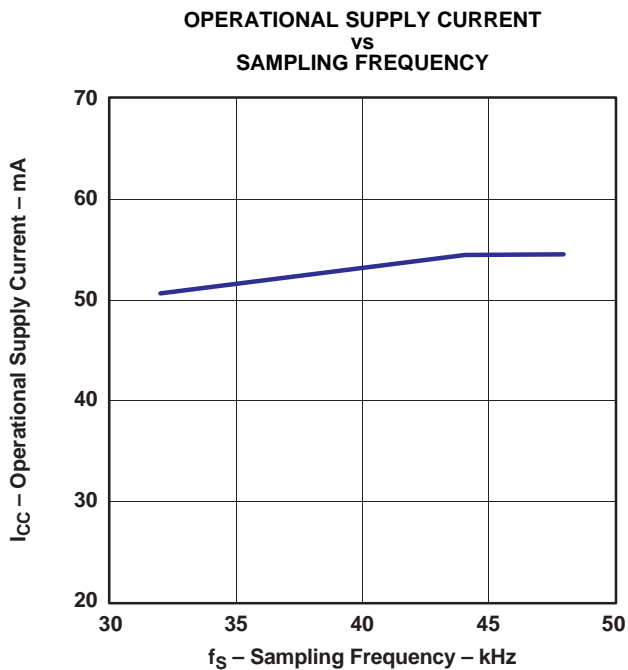

Figure 14. Supply Current vs Sampling Frequency, ADC and DAC at Same  $f_s$

G014

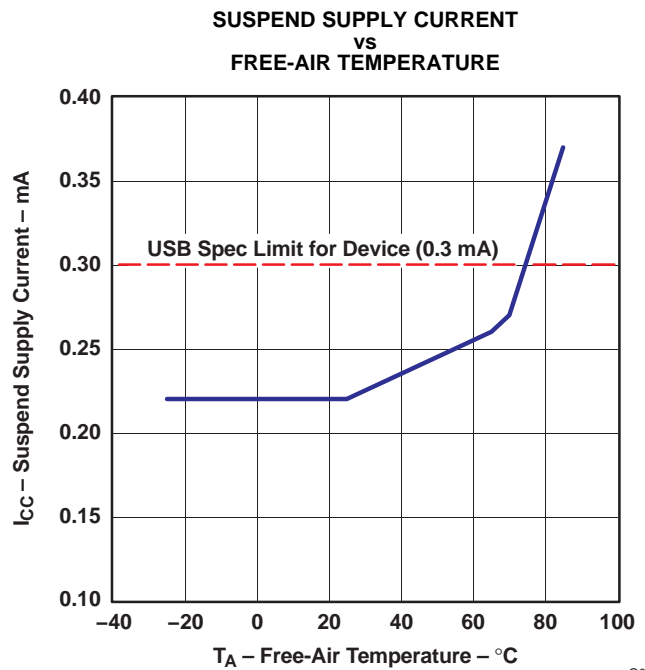

Figure 15. Supply Current vs Temperature in Suspend Mode

G015

### TYPICAL CHARACTERISTICS (continued)

All specifications at  $T_A = 25^\circ\text{C}$ ,  $V_{\text{BUS}} = 5\text{ V}$ ,  $f_s = 44.1\text{ kHz}$ ,  $f_{\text{IN}} = 1\text{ kHz}$ , 16-bit data, unless otherwise noted.

#### ADC DIGITAL DECIMATION FILTER FREQUENCY RESPONSE

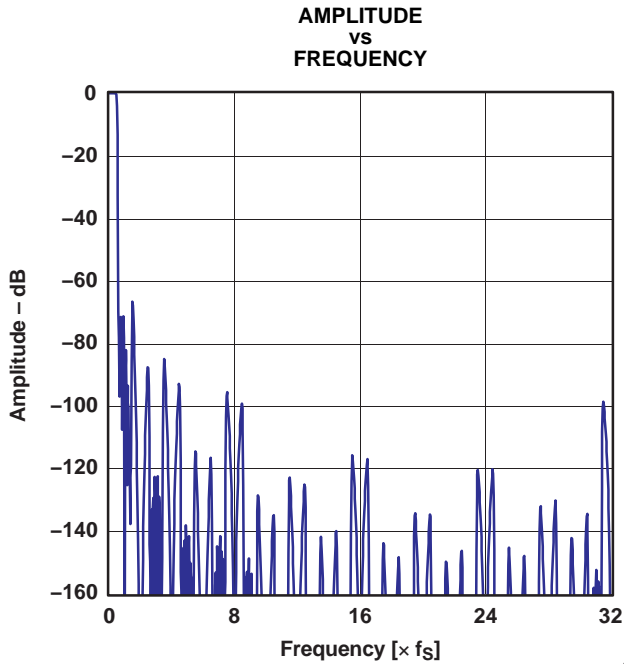

Figure 16. Overall Characteristic

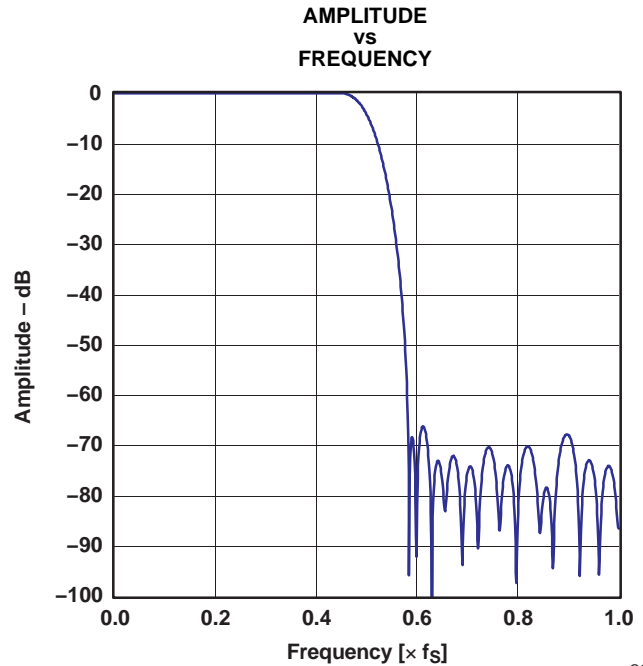

Figure 17. Stop-Band Attenuation

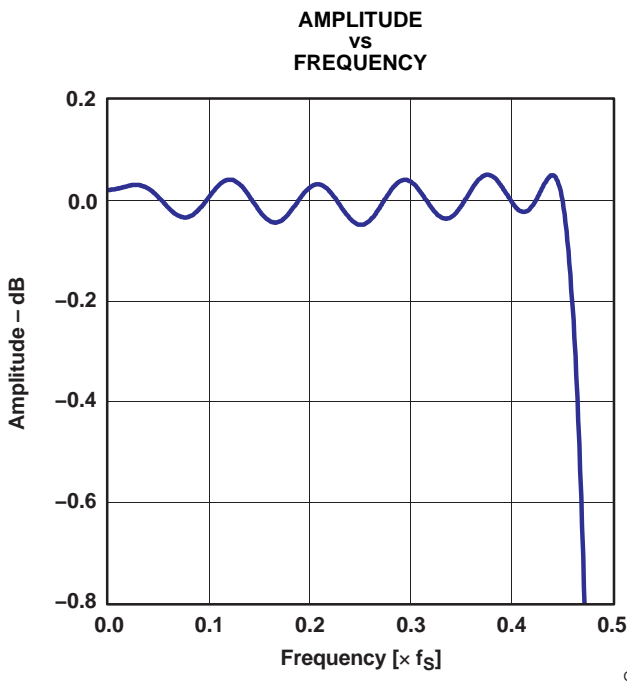

Figure 18. Pass-Band Ripple

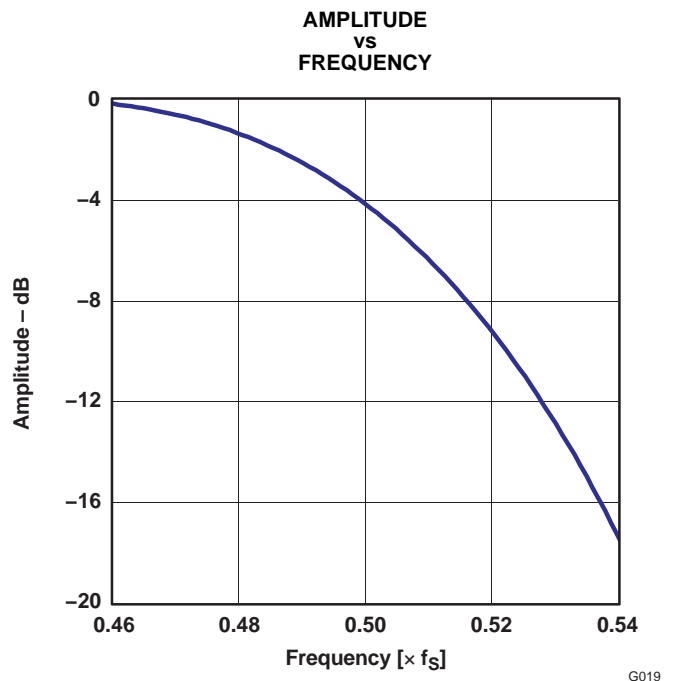

Figure 19. Transition-Band Response

**TYPICAL CHARACTERISTICS (continued)**

All specifications at  $T_A = 25^\circ\text{C}$ ,  $V_{\text{BUS}} = 5\text{ V}$ ,  $f_s = 44.1\text{ kHz}$ ,  $f_{\text{IN}} = 1\text{ kHz}$ , 16-bit data, unless otherwise noted.

**ADC DIGITAL HIGH-PASS FILTER FREQUENCY RESPONSE**

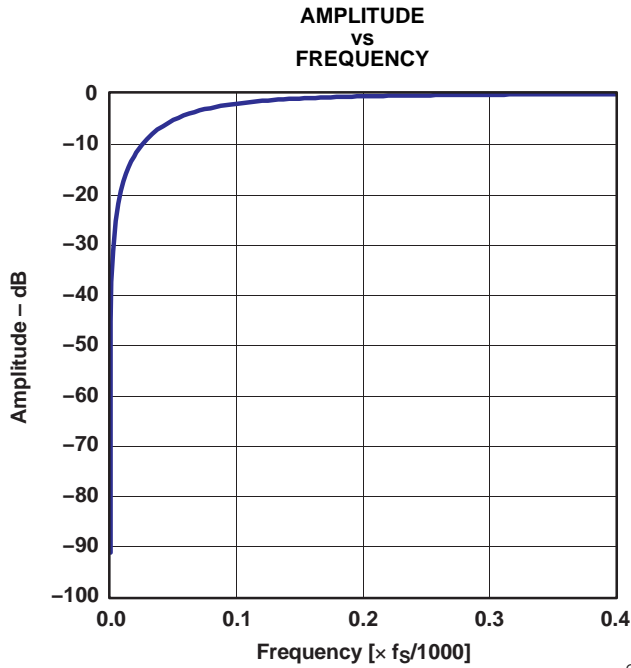

Figure 20. Stop-Band Characteristic

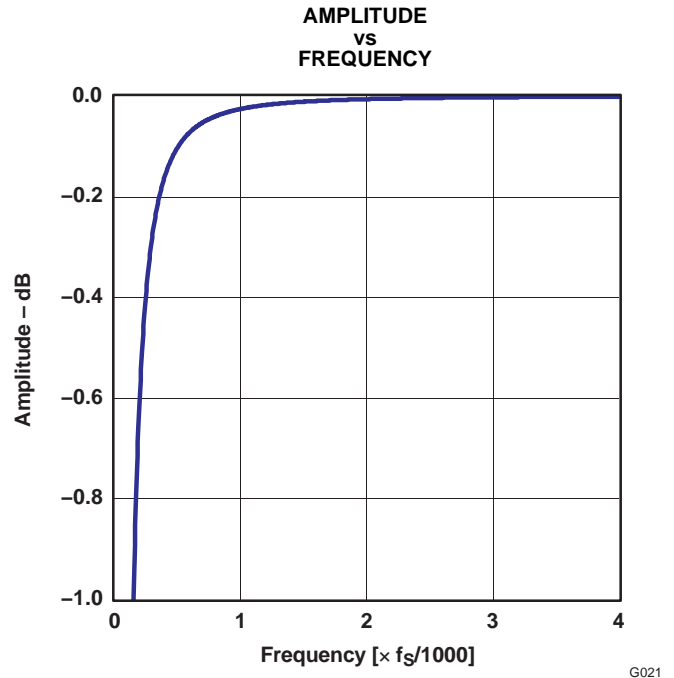

Figure 21. Pass-Band Characteristic

**ADC ANALOG ANTIALIASING FILTER FREQUENCY RESPONSE**

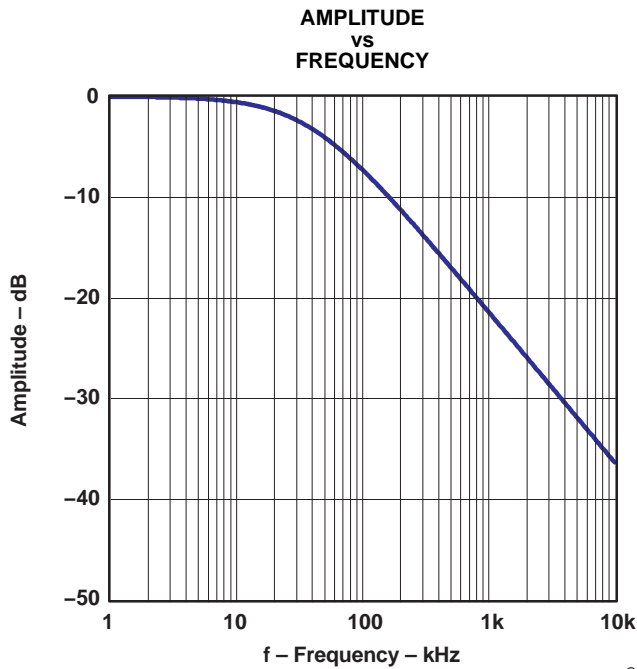

Figure 22. Stop-Band Characteristic

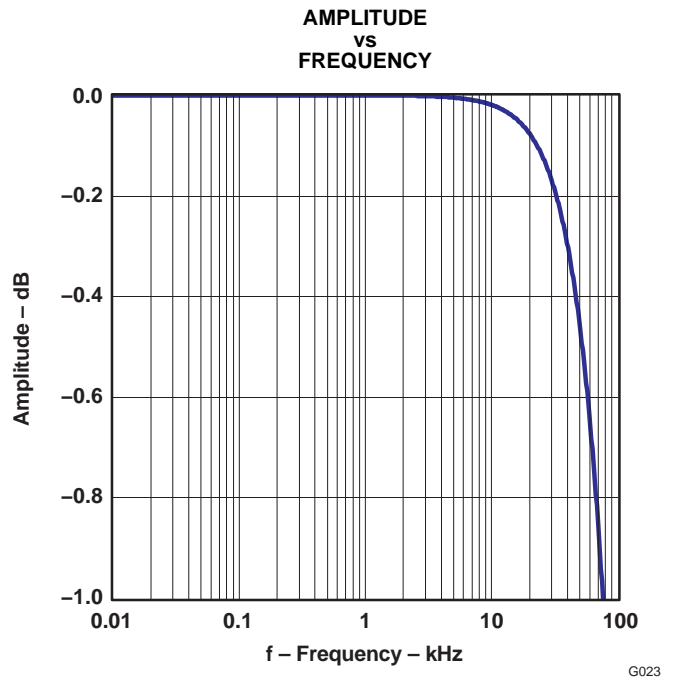

Figure 23. Pass-Band characteristic

**TYPICAL CHARACTERISTICS (continued)**

All specifications at  $T_A = 25^\circ\text{C}$ ,  $V_{\text{BUS}} = 5\text{ V}$ ,  $f_s = 44.1\text{ kHz}$ ,  $f_{\text{IN}} = 1\text{ kHz}$ , 16-bit data, unless otherwise noted.

**DAC DIGITAL INTERPOLATION AND DE-EMPHASIS FILTER FREQUENCY RESPONSE**

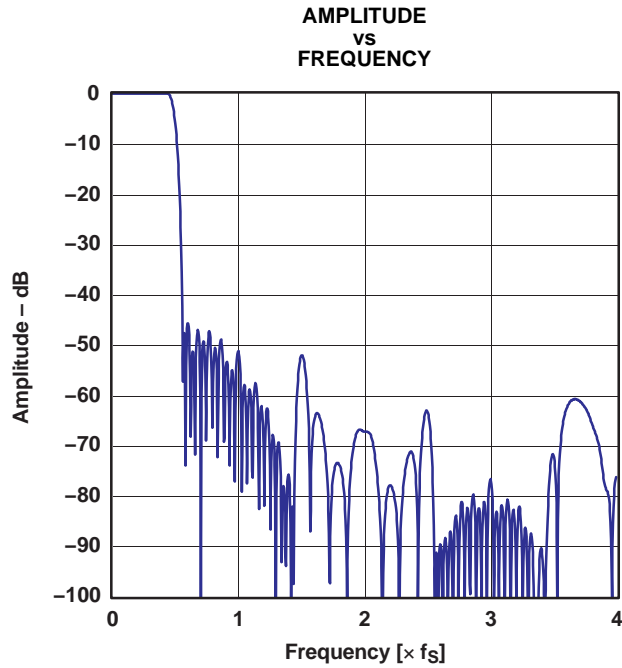

Figure 24. Stop-Band Attenuation

G024

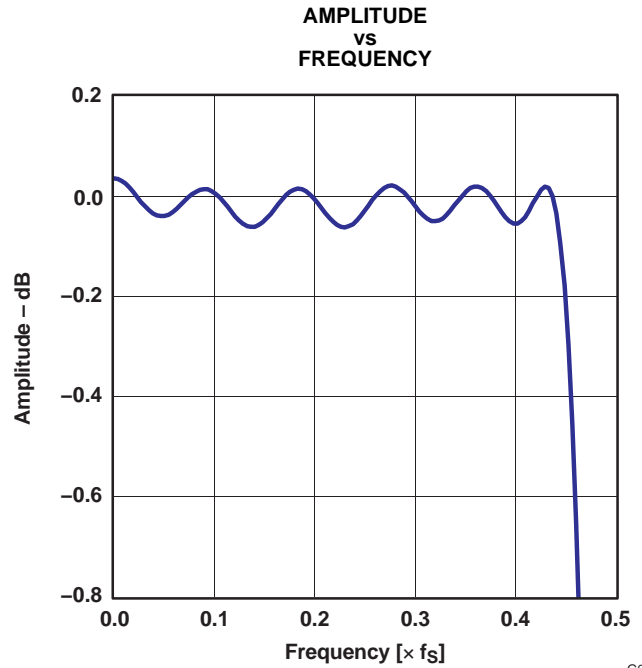

Figure 25. Pass-Band Ripple

G025

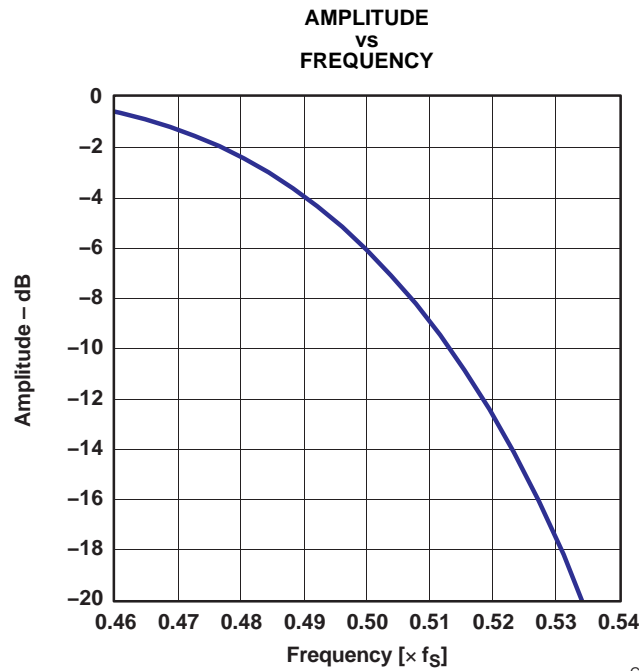

Figure 26. Transition-Band Response

G026

**TYPICAL CHARACTERISTICS (continued)**

All specifications at  $T_A = 25^\circ\text{C}$ ,  $V_{\text{BUS}} = 5\text{ V}$ ,  $f_s = 44.1\text{ kHz}$ ,  $f_{\text{IN}} = 1\text{ kHz}$ , 16-bit data, unless otherwise noted.

**DAC ANALOG FIR FILTER FREQUENCY RESPONSE**

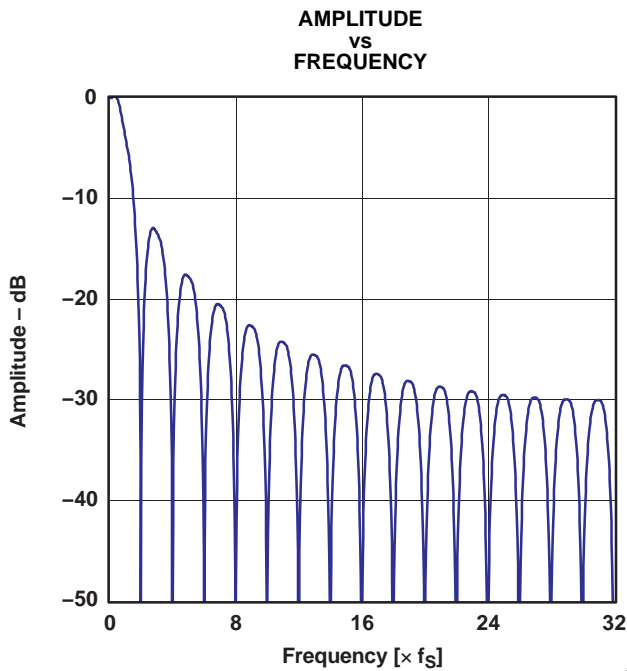

Figure 27. Stop-Band Characteristic

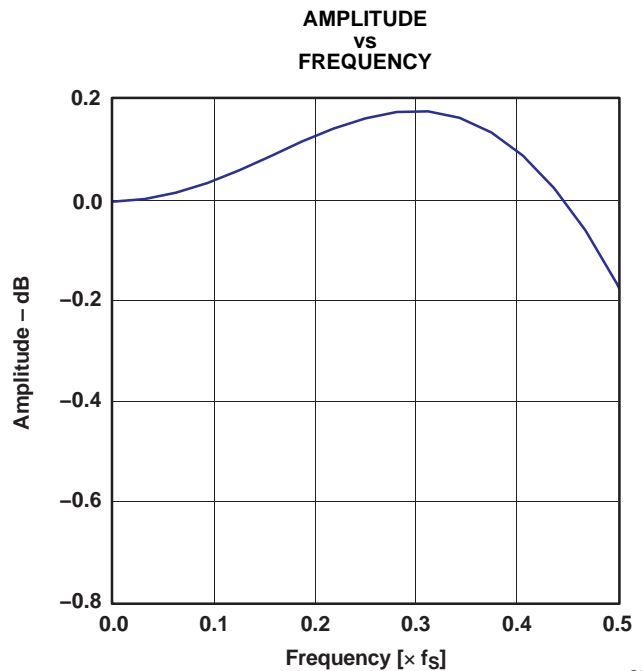

Figure 28. Pass-Band Characteristic

**DAC ANALOG LOW-PASS FILTER FREQUENCY RESPONSE**

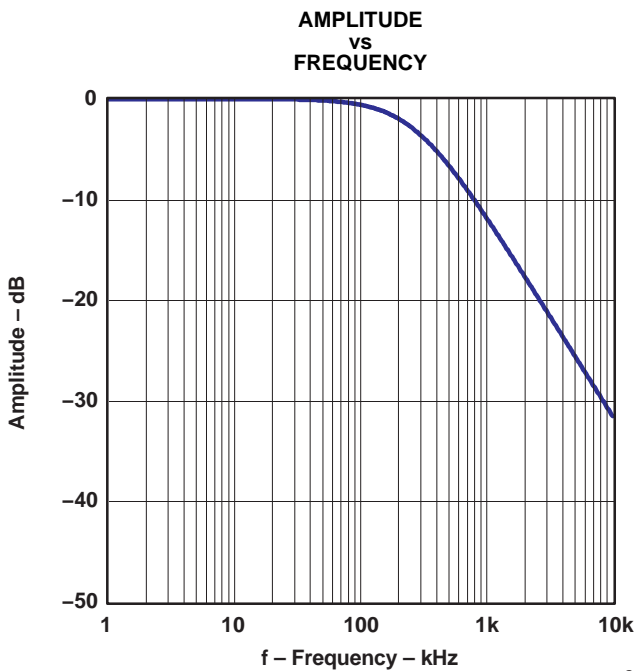

Figure 29. Stop-Band Characteristic

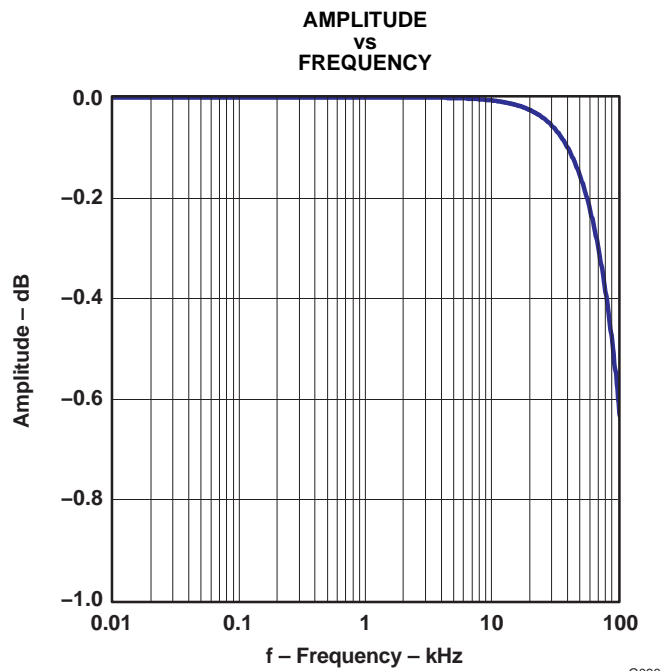

Figure 30. Pass-Band Characteristic

## USB INTERFACE

Control data and audio data are transferred to the PCM2904/2906 via D+ (pin 1) and D– (pin 2). All data to/from the PCM2904/2906 is transferred at full speed. The device descriptor contains the information described in [Table 3](#). The device descriptor can be modified on request; contact a Texas Instruments representative about the details.

**Table 3. Device Descriptor**

USB revision	1.1 compliant
Device class	0x00 (device defined interface level)
Device sub class	0x00 (not specified)
Device protocol	0x00 (not specified)
Max packet size for end-point 0	8 byte
Vendor ID	0x08BB (default value, can be modified)
Product ID	0x2904/0x2906 (default value, can be modified)
Device release number	1.0 (0x0100)
Number of configurations	1
Vendor string	String #1 (see <a href="#">Table 5</a> )
Product string	String #2 (see <a href="#">Table 5</a> )
Serial number	Not supported

The configuration descriptor contains the information described in [Table 4](#). The configuration descriptor can be modified on request; contact a Texas Instruments representative about the details.

**Table 4. Configuration Descriptor**

Interface	Four interfaces
Power attribute	0x80 (Bus powered, no remote wakeup)
Max power	0xFA (500 mA. Default value, can be modified)

The string descriptor contains the information described in [Table 5](#). The string descriptor can be modified on request; contact a Texas Instruments representative about the details.

**Table 5. String Descriptor**

#0	0x0409
#1	Burr-Brown from TI (default value, can be modified)
#2	USB audio codec (default value, can be modified)

**DEVICE CONFIGURATION**

Figure 31 illustrates the USB audio function topology. The PCM2904/2906 has four interfaces. Each interface is constructed by alternative settings.

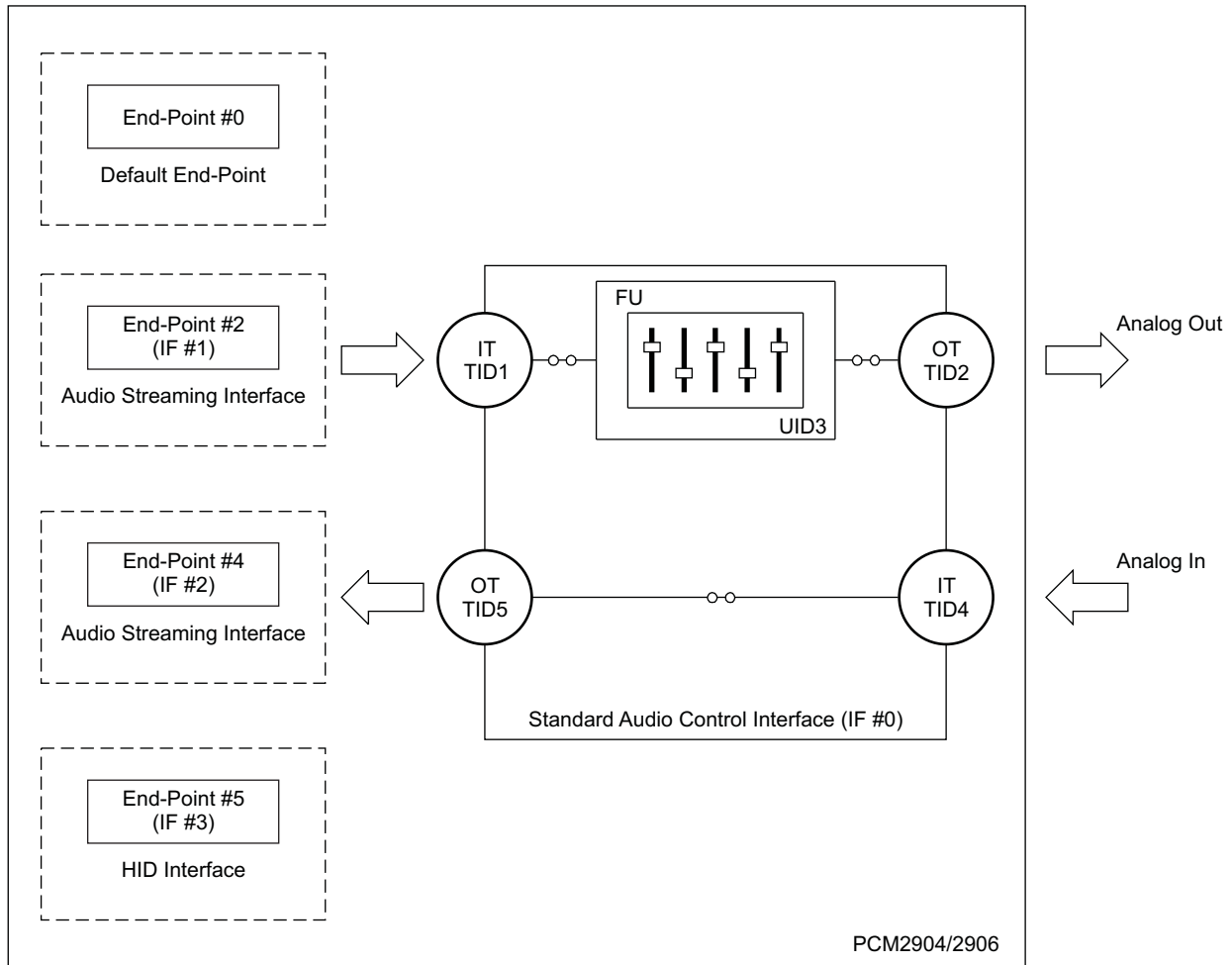

M0024-02

**Figure 31. USB Audio Function Topology**

## Interface #0

Interface #0 is the control interface. Alternative setting #0 is the only possible setting for interface #0. Alternative setting #0 describes the standard audio control interface. The audio control interface is constructed by a terminal. The PCM2904/2906 has the following five terminals.

- Input terminal (IT #1) for isochronous-out stream
- Output terminal (OT #2) for audio analog output
- Feature unit (FU #3) for DAC digital attenuator
- Input terminal (IT #4) for audio analog input
- Output terminal (OT #5) for isochronous-in stream

Input terminal #1 is defined as a *USB stream* (terminal type 0x0101). Input terminal #1 can accept 2-channel audio streams consisting of left and right channels. Output terminal #2 is defined as a *speaker* (terminal type 0x0301). Input terminal #4 is defined as a *microphone* (terminal type 0x0201). Output terminal #5 is defined as a *USB stream* (terminal type 0x0101). Output terminal #5 can generate 2-channel audio streams consisting of left and right channels. Feature unit #3 supports the following sound control features.

- Volume control
- Mute control

The built-in digital volume controller can be manipulated by an audio-class-specific request from 0 dB to –64 dB in steps of 1 dB. Each channel can be set for different values. The master volume control is not supported. A request to the master volume is stalled and ignored. The built-in digital mute controller can be manipulated by audio-class-specific request. A master mute control request is acceptable. A request to an individual channel is stalled and ignored.

## Interface #1

Interface #1 is the audio streaming data-out interface. Interface #1 has the following seven alternative settings. Alternative setting #0 is the zero-bandwidth setting. All other alternative settings are operational settings.

ALTERNATIVE SETTING	DATA FORMAT			TRANSFER MODE	SAMPLING RATE (kHz)
00	Zero bandwidth				
01	16 bit	Stereo	2s complement (PCM)	Adaptive	32, 44.1, 48
02	16 bit	Mono	2s complement (PCM)	Adaptive	32, 44.1, 48
03	8 bit	Stereo	2s complement (PCM)	Adaptive	32, 44.1, 48
04	8 bit	Mono	2s complement (PCM)	Adaptive	32, 44.1, 48
05	8 bit	Stereo	Offset binary (PCM8)	Adaptive	32, 44.1, 48
06	8 bit	Mono	Offset binary (PCM8)	Adaptive	32, 44.1, 48

## Interface #2

Interface #2 is the audio streaming data-in interface. Interface #2 has the following 19 alternative settings. Alternative setting #0 is the zero-bandwidth setting. All other alternative settings are operational settings.

ALTERNATIVE SETTING	DATA FORMAT			TRANSFER MODE	SAMPLING RATE (kHz)
00	ZERO BANDWIDTH				
01	16 bit	Stereo	2s complement (PCM)	Asynchronous	48
02	16 bit	Mono	2s complement (PCM)	Asynchronous	48
03	16 bit	Stereo	2s complement (PCM)	Asynchronous	44.1
04	16 bit	Mono	2s complement (PCM)	Asynchronous	44.1
05	16 bit	Stereo	2s complement (PCM)	Asynchronous	32
06	16 bit	Mono	2s complement (PCM)	Asynchronous	32
07	16 bit	Stereo	2s complement (PCM)	Asynchronous	22.05
08	16 bit	Mono	2s complement (PCM)	Asynchronous	22.05
09	16 bit	Stereo	2s complement (PCM)	Asynchronous	16
0A	16 bit	Mono	2s complement (PCM)	Asynchronous	16
0B	8 bit	Stereo	2s complement (PCM)	Asynchronous	16
0C	8 bit	Mono	2s complement (PCM)	Asynchronous	16
0D	8 bit	Stereo	2s complement (PCM)	Asynchronous	8
0E	8 bit	Mono	2s complement (PCM)	Asynchronous	8
0F	16 bit	Stereo	2s complement (PCM)	Synchronous	11.025
10	16 bit	Mono	2s complement (PCM)	Synchronous	11.025
11	8 bit	Stereo	2s complement (PCM)	Synchronous	11.025
12	8 bit	Mono	2s complement (PCM)	Synchronous	11.025

## Interface #3

Interface #3 is the interrupt data-in interface. Alternative setting #0 is the only possible setting for interface #3. Interface #3 constructs the HID consumer control device. Interface #3 reports the following three key statuses.

- Mute (0xE209)
- Volume up (0xE909)
- Volume down (0xEA09)

## End-Points

The PCM2904/2906 has the following four end-points.

- Control end-point (EP #0)
- Isochronous-out audio data stream end-point (EP #2)
- Isochronous-in audio data stream end-point (EP #4)
- HID end-point (EP #5)

The control end-point is a default end-point. The control end-point is used to control all functions of the PCM2904/2906 by the standard USB request and USB audio class specific request from the host. The isochronous-out audio data stream end-point is an audio sink end-point, which receives the PCM audio data. The isochronous-out audio data stream end-point accepts the adaptive transfer mode. The isochronous-in audio data stream end-point is an audio source end-point that transmits the PCM audio data. The isochronous-in audio data stream end-point uses the asynchronous transfer mode. The HID end-point is an interrupt-in end-point. The HID end-point reports HID0, HID1, and HID2 pin status every 32 ms.

The human interface device (HID) pins are defined as consumer control devices. The HID function is designed as an independent end-point from both isochronous-in and -out end-points. This means that the result obtained from the HID operation depends on the host software. Typically, the HID function is used as a primary audio-out device.

## Clock and Reset

The PCM2904/2906 requires a 12-MHz ( $\pm 500$  ppm) clock for the USB and audio functions. The clock can be generated by a built-in oscillator with a 12-MHz crystal resonator. The 12-MHz crystal resonator must be connected to XTI (pin 21) and XTO (pin 20) with one high-value (1-M $\Omega$ ) resistor and two small capacitors, the capacitance of which depends on the load capacitance of the crystal resonator. An external clock can be supplied to XTI (pin 21). If an external clock is used, XTO (pin 20) must be left open. Because there is no clock disabling signal, use of the external clock supply is not recommended.  $\overline{\text{SSPND}}$  (pin 28) is unable to use clock disabling.

The PCM2904/2906 has an internal power-on reset circuit, which is triggered automatically when  $V_{\text{BUS}}$  (pin 3) exceeds 2.5 V typical (2.7 V to 2.2 V). About 700  $\mu\text{s}$  is required until internal reset release.

## Digital Audio Interface (PCM2906)

The PCM2906 employs S/PDIF for both input and output. Isochronous-out data from the host is encoded to the S/PDIF output and the DAC analog output. Input data is selected from either the S/PDIF or ADC analog input. When the device detects S/PDIF input and successfully locks the received data, the isochronous-in transfer data source automatically selected is S/PDIF; otherwise, the data source selected is the ADC analog input.

## Supported Input Data (PCM2906)

The following data formats are accepted by S/PDIF for input and output. All other data formats are unusable as S/PDIF.

- 48-kHz 16-bit stereo
- 44.1-kHz 16-bit stereo
- 32-kHz 16-bit stereo

Mismatch between the input data format and the host command may cause unexpected results, with the following exceptions:

- Recording in monaural format from stereo data input at the same data rate
- Recording in 8-bit format from 16-bit data input at the same data rate

A combination of the two foregoing conditions is not accepted.

For playback, all possible data-rate sources are converted to the 16-bit stereo format at the same source data rate.

## Channel Status Information (PCM2906)

The channel status information is fixed as consumer application, PCM mode, copyright, and digital/digital converter. All other bits are fixed as 0s except for the sample frequency, which is set automatically according to the data received through the USB.

## Copyright Management (PCM2906)

Isochronous-in data is affected by the serial copy management system (SCMS). When the control bit indicates that the received digital audio data is original, the input digital audio data is transferred to the host. If the data is indicated as first generation or higher, the transferred data is routed to the analog input.

Digital audio data output is always encoded as original with SCMS control.

The implementation of this feature is optional. It is the designer's responsibility to determine whether to implement this feature in a product or not.

## INTERFACE SEQUENCE

### Power-On, Attach, and Playback Sequence

The PCM2904/2906 is ready for setup when the reset sequence has finished and the USB device is attached. After a connection has been established by setup, the PCM2904/PCM2906 is ready to accept USB audio data. While waiting for the audio data (idle state), the analog output is set to bipolar zero (BPZ).

When receiving the audio data, the PCM2904/2906 stores the first audio packet, which contained 1-ms audio data, into the internal storage buffer. The PCM2904/2906 starts playing the audio data when detecting the following start-of-frame (SOF) packet.

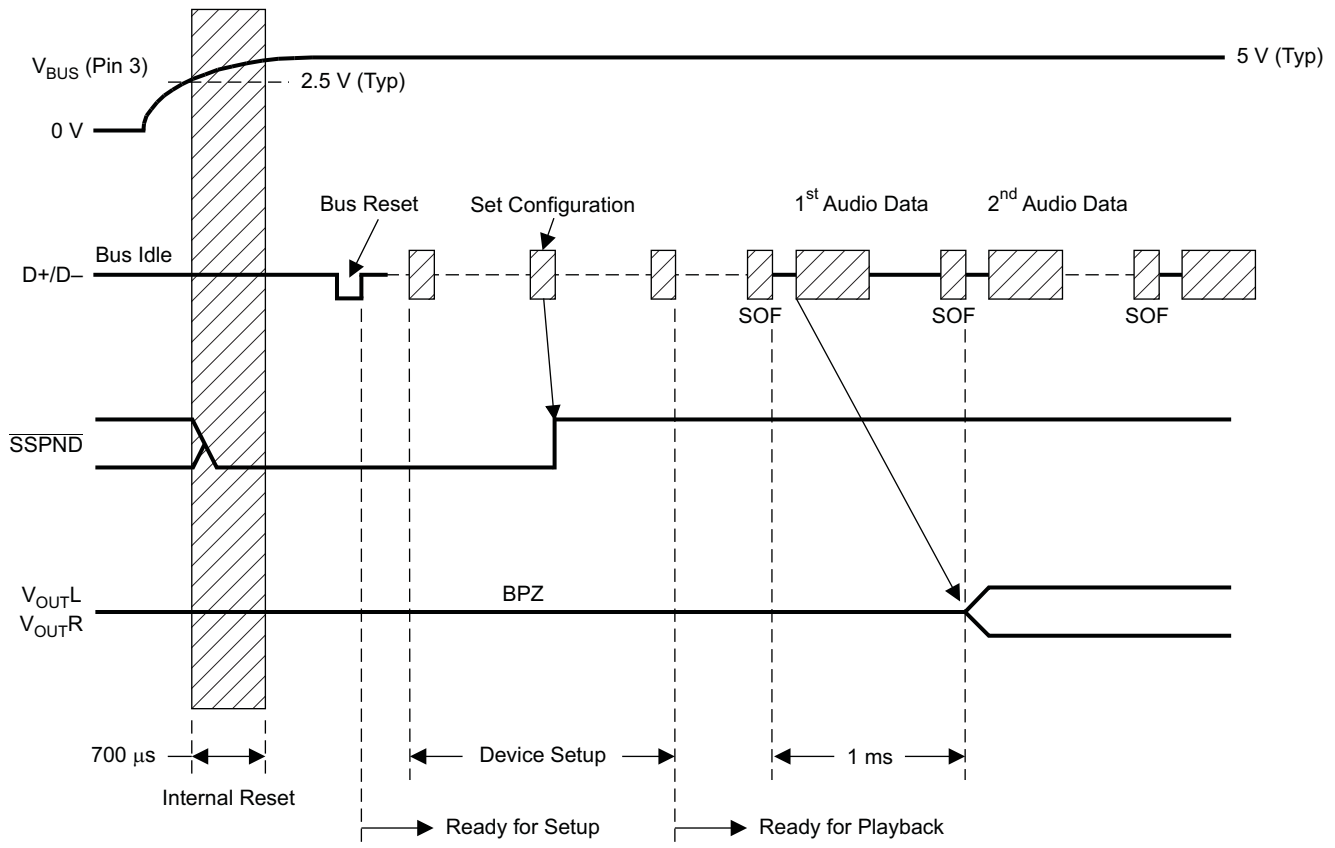

T0055-02

Figure 32. Initial Sequence

### Play, Stop, and Detach Sequence

When the host finishes or aborts the playback, the PCM2904/2906 stops playing after the last audio data has played.

### Record Sequence

The PCM2904/2906 starts audio capture into the internal memory after receiving the SET\_INTERFACE command.

### Suspend and Resume Sequence

The PCM2904/2906 enters the suspend state after a constant idle state on the USB bus, approximately 5 ms. While the PCM2904/2906 enters the suspend state, the SSPND flag (pin 28) is asserted. The PCM2904/2906 wakes up immediately on detecting a non-idle state on the USB.

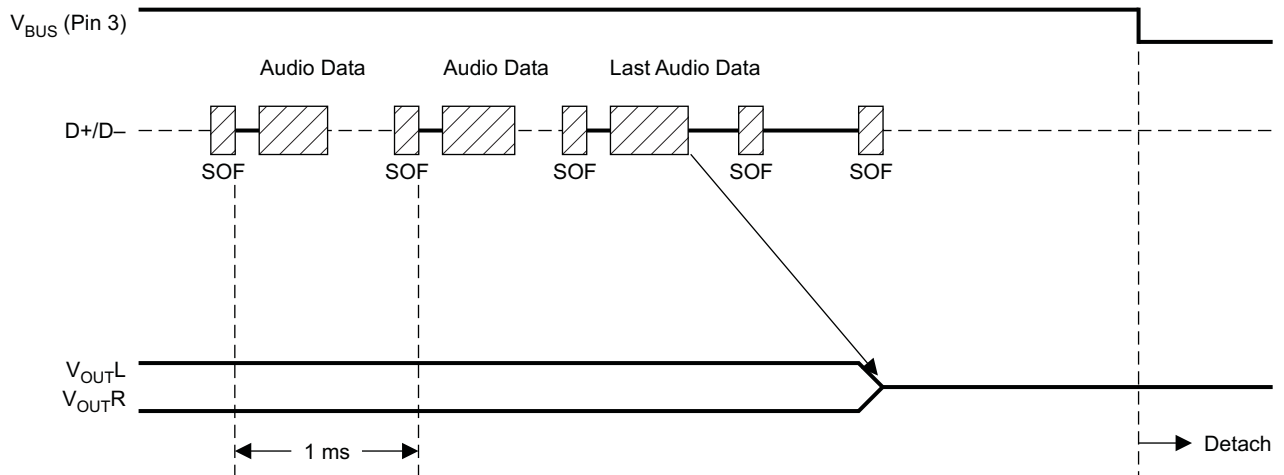

T0056-02

Figure 33. Play, Stop, and Detach

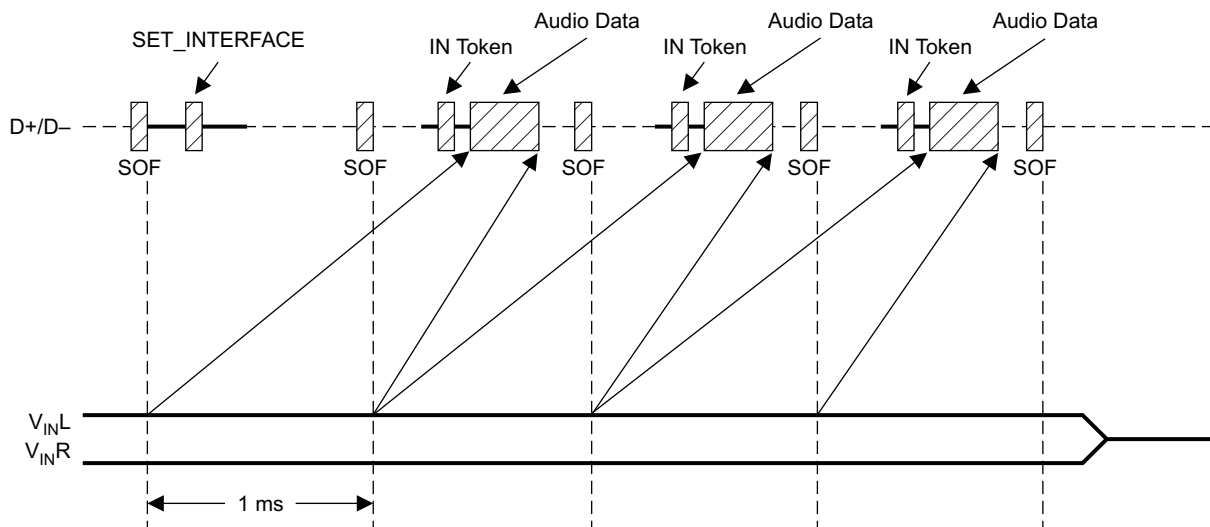

T0259-01

Figure 34. Record Sequence

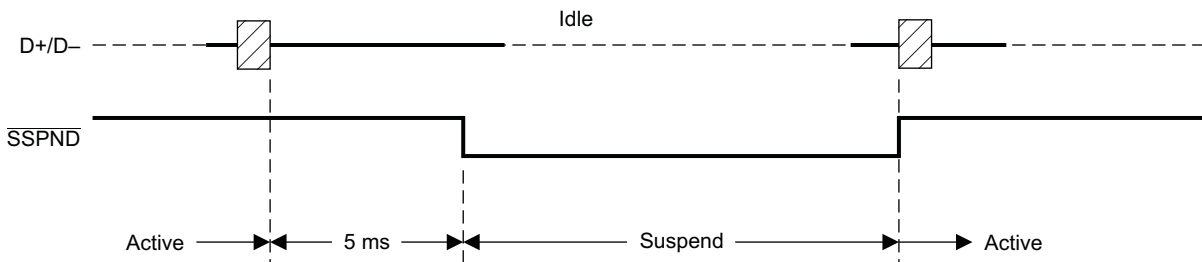

T0057-02

Figure 35. Suspend and Resume

## PCM2904 TYPICAL CIRCUIT CONNECTION 1

Figure 36 illustrates a typical circuit connection for a simple application. The circuit illustrated is for information only. The whole board design should be considered to meet the USB specification as a USB compliant product.

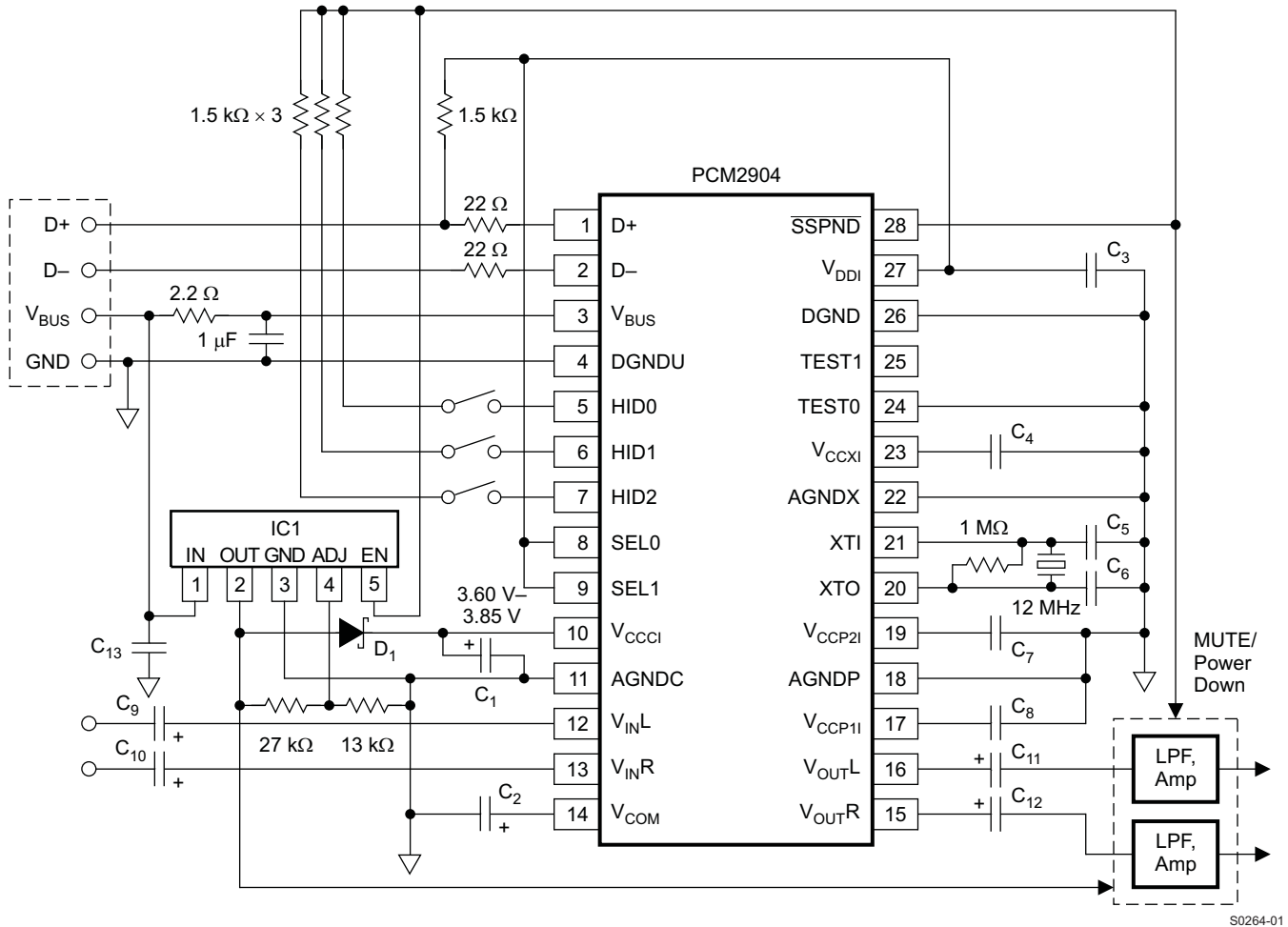

S0264-01

NOTE: C<sub>1</sub>, C<sub>2</sub>: 10 μF  
 C<sub>3</sub>, C<sub>4</sub>, C<sub>7</sub>, C<sub>8</sub>, C<sub>13</sub>: 1 μF (These capacitors must be less than 2 μF.)  
 C<sub>5</sub>, C<sub>6</sub>: 10 pF to 33 pF (depending on crystal resonator)  
 C<sub>9</sub>, C<sub>10</sub>, C<sub>11</sub>, C<sub>12</sub>: The capacitance may vary depending on design.  
 IC1: REG103xA-A (TI) or equivalent. Analog performance may vary depending on IC1.  
 D<sub>1</sub>: Schottky barrier diode (V<sub>F</sub> ≤ 350 mV at 10 mA, I<sub>R</sub> ≤ 2 μA at 4 V)

Figure 36. Bus-Powered Configuration for High-Performance PCM2904 Application

## PCM2906 TYPICAL CIRCUIT CONNECTION 1

Figure 37 illustrates a typical circuit connection for a simple application. The circuit illustrated is for information only. The whole board design should be considered to meet the USB specification as a USB compliant product.

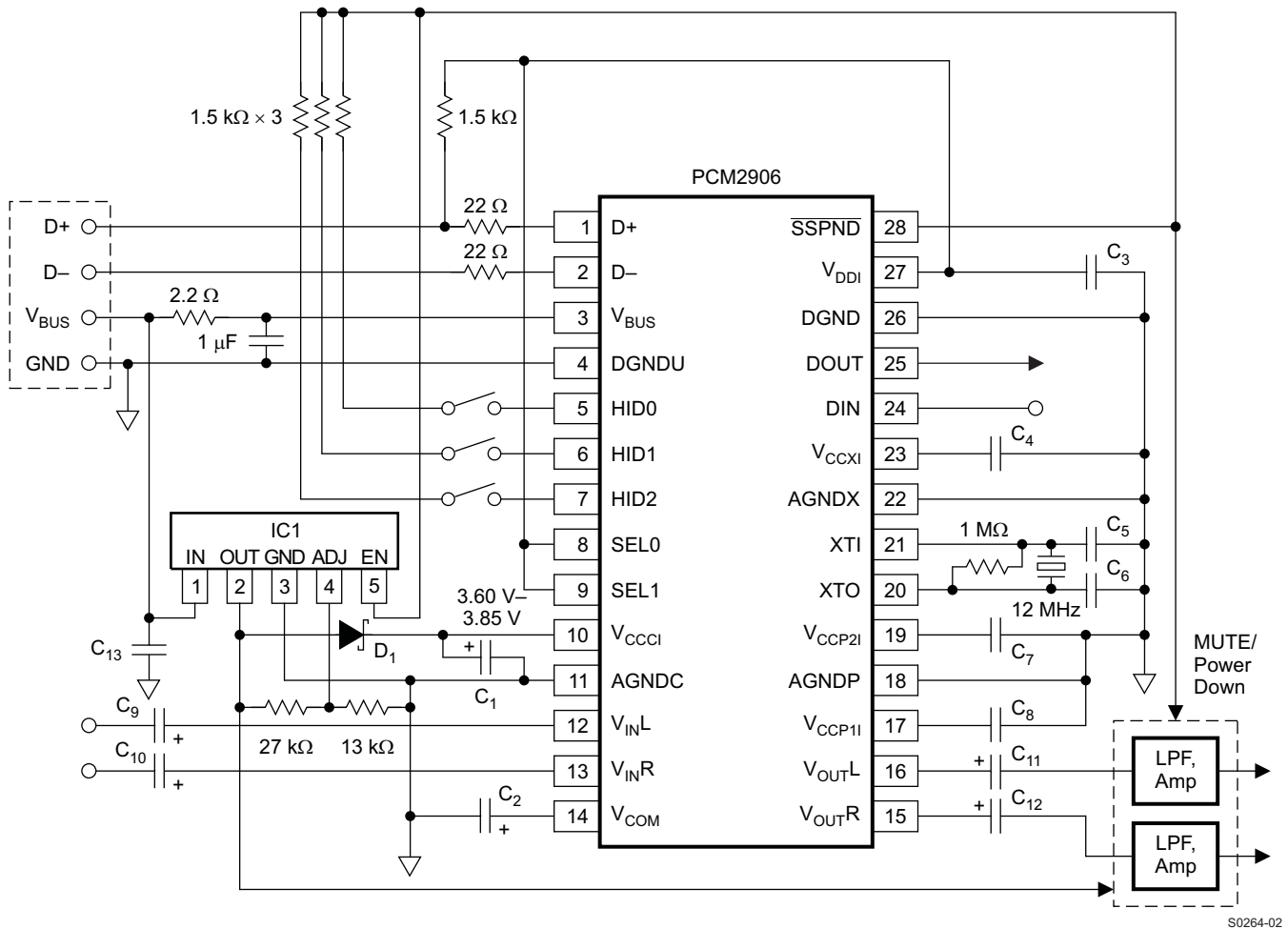

NOTE: C<sub>1</sub>, C<sub>2</sub>: 10 μF  
 C<sub>3</sub>, C<sub>4</sub>, C<sub>7</sub>, C<sub>8</sub>, C<sub>13</sub>: 1 μF (These capacitors must be less than 2 μF.)  
 C<sub>5</sub>, C<sub>6</sub>: 10 pF to 33 pF (depending on crystal resonator)  
 C<sub>9</sub>, C<sub>10</sub>, C<sub>11</sub>, C<sub>12</sub>: The capacitance may vary depending on design.  
 IC1: REG103xA-A (TI) or equivalent. Analog performance may vary depending on IC1.  
 D<sub>1</sub>: Schottky barrier diode (V<sub>F</sub> ≤ 350 mV at 10 mA, I<sub>R</sub> ≤ 2 μA at 4 V)

Figure 37. Bus-Powered Configuration for High-Performance PCM2906 Application

S0264-02

## PCM2904 TYPICAL CIRCUIT CONNECTION 2

Figure 38 illustrates a typical circuit connection for a simple application. The circuit illustrated is for information only. The whole board design should be considered to meet the USB specification as a USB compliant product.

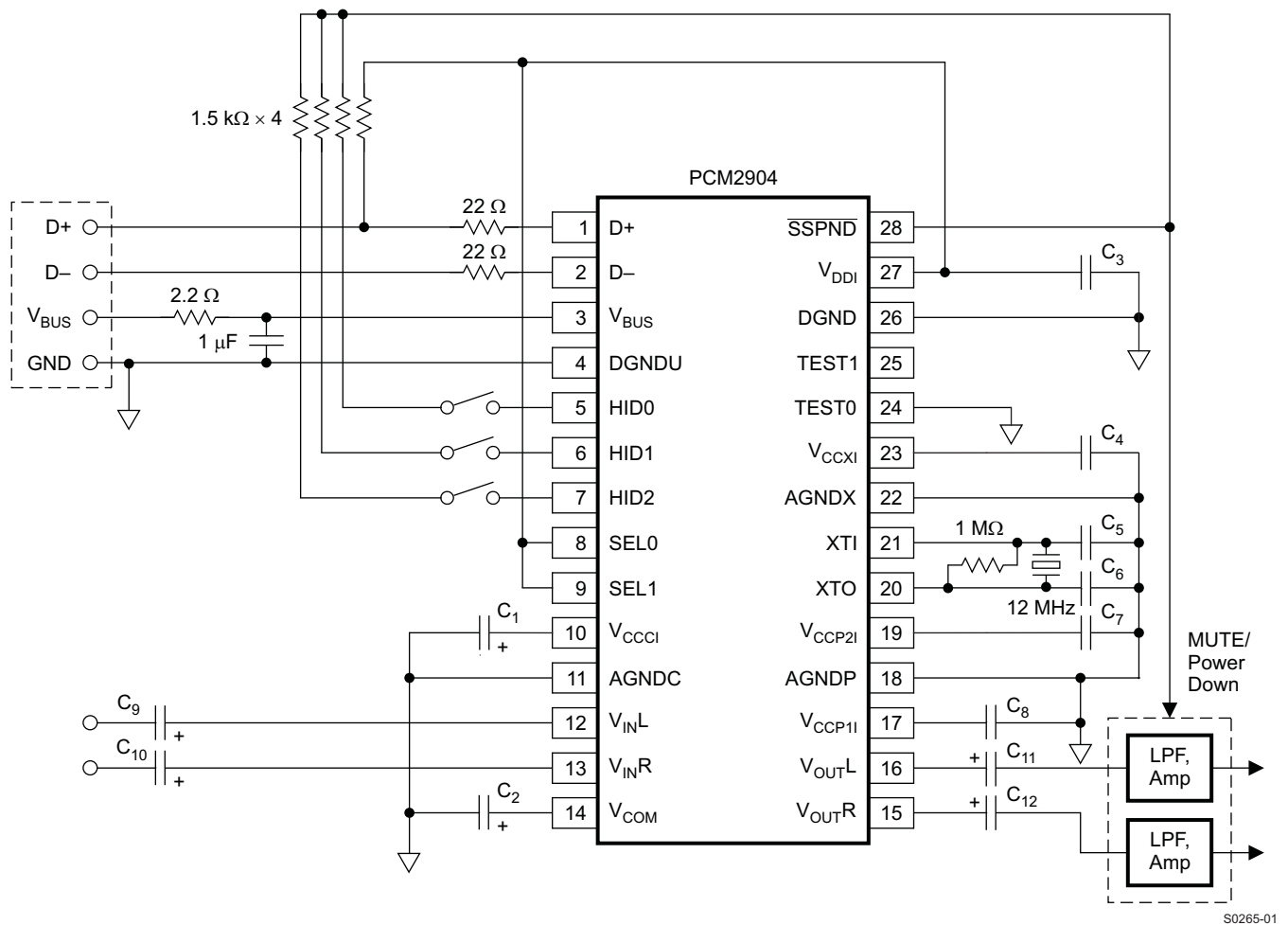

NOTE: C<sub>1</sub>, C<sub>2</sub>: 10 μF  
 C<sub>3</sub>, C<sub>4</sub>, C<sub>7</sub>, C<sub>8</sub>: 1 μF (These capacitors must be less than 2 μF.)  
 C<sub>5</sub>, C<sub>6</sub>: 10 pF to 33 pF (depending on crystal resonator)  
 C<sub>9</sub>, C<sub>10</sub>, C<sub>11</sub>, C<sub>12</sub>: The capacitance may vary depending on design.  
 In this case, the analog performance of the A/D converter may be degraded.

Figure 38. PCM2904 Bus-Powered Configuration

S0265-01

## PCM2906 TYPICAL CIRCUIT CONNECTION 2

Figure 39 illustrates a typical circuit connection for a simple application. The circuit illustrated is for information only. The whole board design should be considered to meet the USB specification as a USB compliant product.

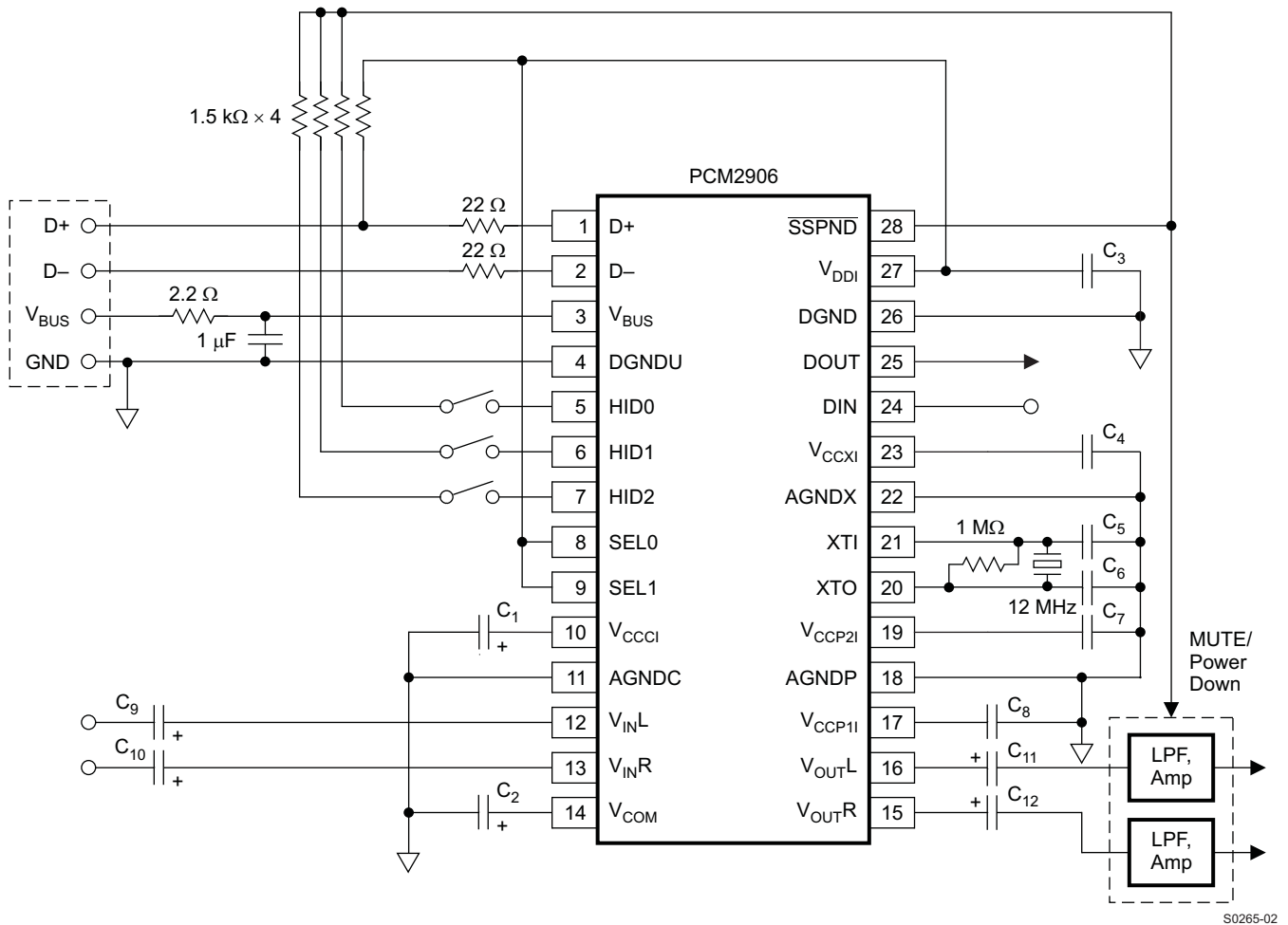

NOTE: C<sub>1</sub>, C<sub>2</sub>: 10 μF  
 C<sub>3</sub>, C<sub>4</sub>, C<sub>7</sub>, C<sub>8</sub>: 1 μF (These capacitors must be less than 2 μF.)  
 C<sub>5</sub>, C<sub>6</sub>: 10 pF to 33 pF (depending on crystal resonator)  
 C<sub>9</sub>, C<sub>10</sub>, C<sub>11</sub>, C<sub>12</sub>: The capacitance may vary depending on design.  
 In this case, the analog performance of the A/D converter may be degraded.

Figure 39. PCM2906 Bus-Powered Configuration

S0265-02

## APPLICATION INFORMATION

### OPERATING ENVIRONMENT

For current information on the PCM2904/2906 operating environment, see the *Updated Operating Environments for PCM270X, PCM290X Applications* application report, [SLAA374](#).

---

## REVISION HISTORY

Changes from Revision B (March 2007) to Revision C	Page
• Deleted operating environment information from data sheet and added reference to application report .....	30

---

DB (R-PDSO-G\*\*)

PLASTIC SMALL-OUTLINE

28 PINS SHOWN



- NOTES: A. All linear dimensions are in millimeters.  
 B. This drawing is subject to change without notice.  
 C. Body dimensions do not include mold flash or protrusion not to exceed 0,15.  
 D. Falls within JEDEC MO-150

## IMPORTANT NOTICE

Texas Instruments Incorporated and its subsidiaries (TI) reserve the right to make corrections, modifications, enhancements, improvements, and other changes to its products and services at any time and to discontinue any product or service without notice. Customers should obtain the latest relevant information before placing orders and should verify that such information is current and complete. All products are sold subject to TI's terms and conditions of sale supplied at the time of order acknowledgment.

TI warrants performance of its hardware products to the specifications applicable at the time of sale in accordance with TI's standard warranty. Testing and other quality control techniques are used to the extent TI deems necessary to support this warranty. Except where mandated by government requirements, testing of all parameters of each product is not necessarily performed.

TI assumes no liability for applications assistance or customer product design. Customers are responsible for their products and applications using TI components. To minimize the risks associated with customer products and applications, customers should provide adequate design and operating safeguards.

TI does not warrant or represent that any license, either express or implied, is granted under any TI patent right, copyright, mask work right, or other TI intellectual property right relating to any combination, machine, or process in which TI products or services are used. Information published by TI regarding third-party products or services does not constitute a license from TI to use such products or services or a warranty or endorsement thereof. Use of such information may require a license from a third party under the patents or other intellectual property of the third party, or a license from TI under the patents or other intellectual property of TI.

Reproduction of TI information in TI data books or data sheets is permissible only if reproduction is without alteration and is accompanied by all associated warranties, conditions, limitations, and notices. Reproduction of this information with alteration is an unfair and deceptive business practice. TI is not responsible or liable for such altered documentation. Information of third parties may be subject to additional restrictions.

Resale of TI products or services with statements different from or beyond the parameters stated by TI for that product or service voids all express and any implied warranties for the associated TI product or service and is an unfair and deceptive business practice. TI is not responsible or liable for any such statements.

TI products are not authorized for use in safety-critical applications (such as life support) where a failure of the TI product would reasonably be expected to cause severe personal injury or death, unless officers of the parties have executed an agreement specifically governing such use. Buyers represent that they have all necessary expertise in the safety and regulatory ramifications of their applications, and acknowledge and agree that they are solely responsible for all legal, regulatory and safety-related requirements concerning their products and any use of TI products in such safety-critical applications, notwithstanding any applications-related information or support that may be provided by TI. Further, Buyers must fully indemnify TI and its representatives against any damages arising out of the use of TI products in such safety-critical applications.

TI products are neither designed nor intended for use in military/aerospace applications or environments unless the TI products are specifically designated by TI as military-grade or "enhanced plastic." Only products designated by TI as military-grade meet military specifications. Buyers acknowledge and agree that any such use of TI products which TI has not designated as military-grade is solely at the Buyer's risk, and that they are solely responsible for compliance with all legal and regulatory requirements in connection with such use.

TI products are neither designed nor intended for use in automotive applications or environments unless the specific TI products are designated by TI as compliant with ISO/TS 16949 requirements. Buyers acknowledge and agree that, if they use any non-designated products in automotive applications, TI will not be responsible for any failure to meet such requirements.

Following are URLs where you can obtain information on other Texas Instruments products and application solutions:

### Products

Amplifiers	<a href="http://amplifier.ti.com">amplifier.ti.com</a>
Data Converters	<a href="http://dataconverter.ti.com">dataconverter.ti.com</a>
DLP® Products	<a href="http://www.dlp.com">www.dlp.com</a>
DSP	<a href="http://dsp.ti.com">dsp.ti.com</a>
Clocks and Timers	<a href="http://www.ti.com/clocks">www.ti.com/clocks</a>
Interface	<a href="http://interface.ti.com">interface.ti.com</a>
Logic	<a href="http://logic.ti.com">logic.ti.com</a>
Power Mgmt	<a href="http://power.ti.com">power.ti.com</a>
Microcontrollers	<a href="http://microcontroller.ti.com">microcontroller.ti.com</a>
RFID	<a href="http://www.ti-rfid.com">www.ti-rfid.com</a>
RF/IF and ZigBee® Solutions	<a href="http://www.ti.com/lprf">www.ti.com/lprf</a>

### Applications

Audio	<a href="http://www.ti.com/audio">www.ti.com/audio</a>
Automotive	<a href="http://www.ti.com/automotive">www.ti.com/automotive</a>
Broadband	<a href="http://www.ti.com/broadband">www.ti.com/broadband</a>
Digital Control	<a href="http://www.ti.com/digitalcontrol">www.ti.com/digitalcontrol</a>
Medical	<a href="http://www.ti.com/medical">www.ti.com/medical</a>
Military	<a href="http://www.ti.com/military">www.ti.com/military</a>
Optical Networking	<a href="http://www.ti.com/opticalnetwork">www.ti.com/opticalnetwork</a>
Security	<a href="http://www.ti.com/security">www.ti.com/security</a>
Telephony	<a href="http://www.ti.com/telephony">www.ti.com/telephony</a>
Video & Imaging	<a href="http://www.ti.com/video">www.ti.com/video</a>
Wireless	<a href="http://www.ti.com/wireless">www.ti.com/wireless</a>

Mailing Address: Texas Instruments, Post Office Box 655303, Dallas, Texas 75265  
Copyright © 2009, Texas Instruments Incorporated

## Looking for pricing, stock, or lifecycle information?

Click below to explore more details on WIN SOURCE:

 [View PCM2904DB](#) on WIN SOURCE

 [Texas Instruments](#) Information

## Optimize Your Supply Chain with WIN SOURCE Solutions

-  Global Sourcing Solution
-  Obsolete Management
-  Cost Control Management
-  Shortage Management
-  Alternative Solution
-  Excess Inventory Management