



# THE DATASHEET OF PCM2704DBR



## STEREO AUDIO DAC WITH USB INTERFACE, SINGLE-ENDED HEADPHONE OUTPUT AND S/PDIF OUTPUT

### FEATURES

- **On-Chip USB Interface:**
  - No Need of Dedicated Device Driver
  - With Full-Speed Transceivers
  - Fully Compliant With USB 1.1 Specification
  - Certified by USB-IF
  - Partially Programmable Descriptors
  - Adaptive Isochronous Transfer for Playback
  - Bus-Powered or Self-Powered Operation
- **Sampling Rate: 32, 44.1, 48 kHz**
- **On-Chip Clock Generator With Single 12-MHz Clock Source**
- **Single Power Supply:**
  - Bus-Powered: 5 V, Typical ( $V_{BUS}$ )
  - Self-Powered: 3.3 V, Typical
- **16-Bit Delta-Sigma Stereo DAC**
  - **Analog Performance at 5 V (Bus-Powered), 3.3 V (Self-Powered):**
    - THD+N: 0.006%  $R_L > 10\ \Omega$ , Self-Powered
    - THD+N: 0.025%  $R_L = 32\ \Omega$
    - SNR = 98 dB
    - Dynamic Range: 98 dB
    - $P_O = 12\ \text{mW}$ ,  $R_L = 32\ \Omega$
  - Oversampling Digital Filter
    - Pass-Band Ripple =  $\pm 0.04\ \text{dB}$
    - Stop-Band Attenuation =  $-50\ \text{dB}$
  - Single-Ended Voltage Output
  - Analog LPF Included
- **Multiple Functions:**
  - Up to Eight Human Interface Device (HID) Interfaces (Depending on Model and Settings)
  - Suspend Flag
  - S/PDIF Out With SCMS

- External ROM Interface (PCM2704/6)
- Serial Programming Interface (PCM2705/7)
- I<sup>2</sup>S Interface (Selectable on PCM2706/7)
- **Package:**
  - 28-Pin SSOP (PCM2704/5)
  - 32-Pin TQFP (PCM2706/7)

### APPLICATIONS

- USB Headphones
- USB Audio Speaker
- USB CRT/LCD Monitor
- USB Audio Interface Box
- USB-Featured Consumer Audio Product

### DESCRIPTION

The PCM2704/5/6/7 is TI's single-chip USB stereo audio DAC with USB-compliant full-speed protocol controller and S/PDIF. The USB-protocol controller works with no software code, but USB descriptors can be modified in some parts (for example, vendor ID/product ID) through the use of an external ROM (PCM2704/6), SPI (PCM2705/7), or on request. <sup>(1)</sup> The PCM2704/5/6/7 employs SpAct™ architecture, TI's unique system that recovers the audio clock from USB packet data. On-chip analog PLLs with SpAct enable playback with low clock jitter.

(1) The modification of the USB descriptor through external ROM or SPI must comply with USB-IF guidelines, and the vendor ID must be your own ID as assigned by the USB-IF. The descriptor also can be modified by changing a mask; contact your representative for details.



Please be aware that an important notice concerning availability, standard warranty, and use in critical applications of Texas Instruments semiconductor products and disclaimers thereto appears at the end of this data sheet.

SpAct is a trademark of Texas Instruments.  
System Two, Audio Precision are trademarks of Audio Precision, Inc.  
I2S is a trademark of NXP Semiconductors.  
All other trademarks are the property of their respective owners.



This integrated circuit can be damaged by ESD. Texas Instruments recommends that all integrated circuits be handled with appropriate precautions. Failure to observe proper handling and installation procedures can cause damage.

ESD damage can range from subtle performance degradation to complete device failure. Precision integrated circuits may be more susceptible to damage because very small parametric changes could cause the device not to meet its published specifications.

## ABSOLUTE MAXIMUM RATINGS

over operating free-air temperature range unless otherwise noted <sup>(1)</sup>

Supply voltage	V <sub>BUS</sub>	–0.3 V to 6.5 V
	V <sub>CCP</sub> , V <sub>CCL</sub> , V <sub>CCR</sub> , V <sub>DD</sub>	–0.3 V to 4 V
Supply voltage differences	V <sub>CCP</sub> , V <sub>CCL</sub> , V <sub>CCR</sub> , V <sub>DD</sub>	±0.1 V
Ground voltage differences	PGND, AGNDL, AGNDR, DGND, ZGND	±0.1 V
Digital input voltage	HOST	–0.3 V to 6.5 V
	D+, D–, HID0/MS, HID1/MC, HID2/MD, XT1, XTO, DOUT, $\overline{\text{SSPND}}$ , CK, DT, PSEL, FSEL, TEST, TEST0, TEST1, FUNC0, FUNC1, FUNC2, FUNC3	–0.3 V to (V <sub>DD</sub> + 0.3) V < 4 V
Analog input voltage	V <sub>COM</sub>	–0.3 V to (V <sub>CCP</sub> + 0.3) V < 4 V
	V <sub>OUTR</sub>	–0.3 V to (V <sub>CCR</sub> + 0.3) V < 4 V
	V <sub>OUTL</sub>	–0.3 V to (V <sub>CCL</sub> + 0.3) V < 4 V
Input current (any pins except supplies)		±10 mA
Ambient temperature under bias		–40°C to 125°C
Storage temperature		–55°C to 150°C
Junction temperature		150°C
Lead temperature (soldering)		260°C, 5 s
Package temperature (IR reflow, peak)		260°C

- (1) Stresses beyond those listed under *Absolute Maximum Ratings* may cause permanent damage to the device. These are stress ratings only, and functional operation of the device at these or any other conditions beyond those indicated under *Recommended Operating Conditions* is not implied. Exposure to absolute-maximum-rated conditions for extended periods may affect device reliability.

## RECOMMENDED OPERATING CONDITIONS

over operating free-air temperature range

		MIN	NOM	MAX	UNIT
Supply voltage	V <sub>BUS</sub>	4.35	5	5.25	V
	V <sub>CCP</sub> , V <sub>CCL</sub> , V <sub>CCR</sub> , V <sub>DD</sub>	3	3.3	3.6	
Digital input logic level		TTL compatible			
Digital input clock frequency		11.994	12	12.006	MHz
Analog output load resistance		16	32		Ω
Analog output load capacitance				100	pF
Digital output load capacitance				20	pF
Operating free-air temperature, T <sub>A</sub>		–25		85	C

## ELECTRICAL CHARACTERISTICS

 all specifications at  $T_A = 25^\circ\text{C}$ ,  $V_{\text{BUS}} = 5\text{ V}$ ,  $f_s = 44.1\text{ kHz}$ ,  $f_{\text{IN}} = 1\text{ kHz}$ , 16-bit data (unless otherwise noted)

PARAMETER		TEST CONDITIONS	PCM2704DB, PCM2705DB, PCM2706PJT, PCM2707PJT			UNIT
			MIN	TYP	MAX	
<b>DIGITAL INPUT/OUTPUT</b>						
Host interface			Apply USB revision 1.1, full-speed			
Audio data format			USB isochronous data format			
<b>INPUT LOGIC</b>						
$V_{\text{IH}}$	Input logic level		2		3.3	Vdc
$V_{\text{IL}}$			-0.3		0.8	
$V_{\text{IH}}^{(1)}$			2		5.5	
$V_{\text{IL}}^{(1)}$			-0.3		0.8	
$I_{\text{IH}}^{(2)}$	Input logic current	$V_{\text{IN}} = 3.3\text{ V}$			$\pm 10$	$\mu\text{A}$
$I_{\text{IL}}^{(2)}$		$V_{\text{IN}} = 0\text{ V}$			$\pm 10$	
$I_{\text{IH}}$		$V_{\text{IN}} = 3.3\text{ V}$		65	100	
$I_{\text{IL}}$		$V_{\text{IN}} = 0\text{ V}$			$\pm 10$	
<b>OUTPUT LOGIC</b>						
$V_{\text{OH}}^{(3)}$	Output logic level	$I_{\text{OH}} = -2\text{ mA}$	2.8			Vdc
$V_{\text{OL}}^{(3)}$		$I_{\text{OL}} = 2\text{ mA}$			0.3	
$V_{\text{OH}}$		$I_{\text{OH}} = -2\text{ mA}$	2.4			
$V_{\text{OL}}$		$I_{\text{OL}} = 2\text{ mA}$			0.4	
<b>CLOCK FREQUENCY</b>						
Input clock frequency, XTI			11.994	12	12.006	MHz
$f_s$	Sampling frequency		32, 44.1, 48			kHz
<b>DAC CHARACTERISTICS</b>						
Resolution			16			Bits
Audio data channel			1, 2			Channel
<b>DC ACCURACY</b>						
Gain mismatch, channel-to-channel			$\pm 2$		$\pm 8$	% of FSR
Gain error			$\pm 2$		$\pm 8$	% of FSR
Bipolar zero error			$\pm 3$		$\pm 6$	% of FSR
<b>DYNAMIC PERFORMANCE <sup>(4)</sup></b>						
THD+N	Total harmonic distortion + noise	Line <sup>(5)</sup>	$R_L > 10\text{ k}\Omega$ , self-powered, $V_{\text{OUT}} = 0\text{ dB}$	0.006%	0.01%	
			$R_L > 10\text{ k}\Omega$ , bus-powered, $V_{\text{OUT}} = 0\text{ dB}$	0.012%	0.02%	
		Headphone	$R_L = 32\ \Omega$ , self-/bus-powered, $V_{\text{OUT}} = 0\text{ dB}$	0.025%		
THD+N	Total harmonic distortion + noise	$V_{\text{OUT}} = -60\text{ dB}$	2%			
Dynamic range		EIAJ, A-weighted	90	98		dB
S/N	Signal-to-noise ratio	EIAJ, A-weighted	90	98		dB
Channel separation			60	70		dB

(1) HOST

(2) D+, D-, HOST, TEST, TEST0, TEST1, DT, PSEL, FSEL, XTI

(3) FUNC0, FUNC1, FUNC2

 (4)  $f_{\text{IN}} = 1\text{ kHz}$ , using the System Two™ Cascade audio measurement system by Audio Precision™ in the RMS mode with a 20-kHz LPF and 400-Hz HPF.

 (5) THD+N performance varies slightly, depending on the effective output load, including dummy load R7, R8 in [Figure 32](#).

## ELECTRICAL CHARACTERISTICS (continued)

all specifications at  $T_A = 25^\circ\text{C}$ ,  $V_{\text{BUS}} = 5\text{ V}$ ,  $f_s = 44.1\text{ kHz}$ ,  $f_{\text{IN}} = 1\text{ kHz}$ , 16-bit data (unless otherwise noted)

PARAMETER		TEST CONDITIONS	PCM2704DB, PCM2705DB, PCM2706PJT, PCM2707PJT			UNIT	
			MIN	TYP	MAX		
<b>ANALOG OUTPUT</b>							
Output voltage			0.55 $V_{\text{CCL}}$ , 0.55 $V_{\text{CCR}}$			Vp-p	
Center voltage			0.5 $V_{\text{CCP}}$			V	
Load impedance	Line	AC coupling	10			k $\Omega$	
	Headphone	AC coupling	16	32		$\Omega$	
LPF frequency response		–3 dB	140			kHz	
		f = 20 kHz	–0.1			dB	
<b>DIGITAL FILTER PERFORMANCE</b>							
Pass band			0.454 $f_s$			Hz	
Stop band			0.546 $f_s$			Hz	
Pass-band ripple			$\pm 0.04$			dB	
Stop-band attenuation			–50			dB	
Delay time			20/ $f_s$			s	
<b>POWER SUPPLY REQUIREMENTS</b>							
Voltage range	$V_{\text{BUS}}$	Bus-powered	4.35	5	5.25	Vdc	
	$V_{\text{CCP}}$ , $V_{\text{CCL}}$ , $V_{\text{CCR}}$ , $V_{\text{DD}}$	Self-powered	3	3.3	3.6		
Supply current	Line	DAC operation	23			mA	
	Headphone	DAC operation $R_L = 32\ \Omega$	35				
	Line/headphone	Suspend mode <sup>(6)</sup>	150			$\mu\text{A}$	
Power dissipation (self-powered)	Line	DAC operation	76			mW	
	Headphone	DAC operation $R_L = 32\ \Omega$	116				
	Line/headphone	Suspend mode <sup>(6)</sup>	495			$\mu\text{W}$	
Power dissipation (bus-powered)	Line	DAC operation	115			mW	
	Headphone	DAC operation $R_L = 32\ \Omega$	175				
	Line/headphone	Suspend mode <sup>(6)</sup>	750			$\mu\text{W}$	
Internal power-supply voltage <sup>(7)</sup>	$V_{\text{CCP}}$ , $V_{\text{CCL}}$ , $V_{\text{CCR}}$ , $V_{\text{DD}}$	Bus-powered	3.2	3.35	3.5	Vdc	
<b>TEMPERATURE RANGE</b>							
Operating temperature			–25			85	$^\circ\text{C}$
$\theta_{\text{JA}}$	Thermal resistance	28-pin SSOP (PCM2704/5)	100			$^\circ\text{C/W}$	
		32-pin TQFP (PCM2706/7)	80				

(6) Under USB suspend state.

(7)  $V_{\text{DD}}$ ,  $V_{\text{CCP}}$ ,  $V_{\text{CCL}}$ ,  $V_{\text{CCR}}$ . These pins work as output pins of internal power supply for bus-powered operation.

**PIN ASSIGNMENTS**

**PCM2704/PCM2705  
DB PACKAGE  
(TOP VIEW)**

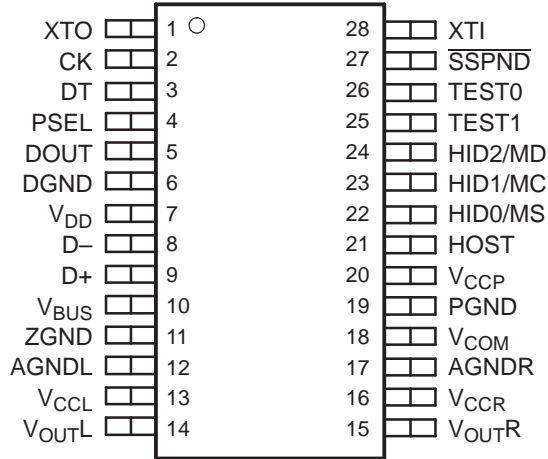

**PCM2706/PCM2707  
PJT PACKAGE  
(TOP VIEW)**

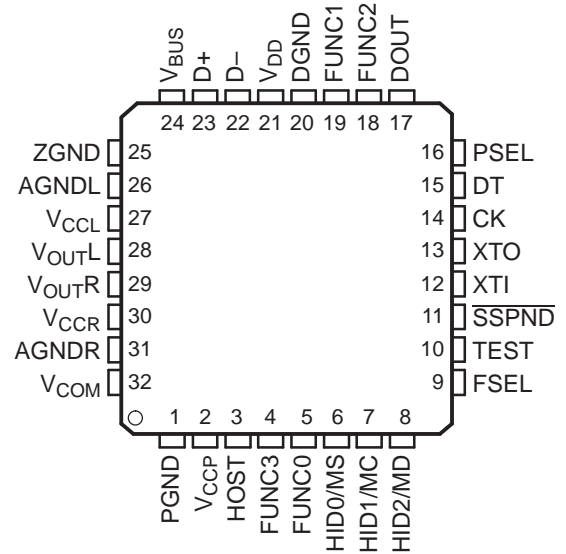

P0020-01

### Terminal Functions (PCM2704DB/PCM2705DB)

TERMINAL NAME	NO.	I/O	DESCRIPTION
AGNDL	12	—	Analog ground for headphone amplifier of L-channel
AGNDR	17	—	Analog ground for headphone amplifier of R-channel
CK	2	O	Clock output for external ROM (PCM2704). Must be left open (PCM2705).
D+	9	I/O	USB differential input/output plus <sup>(1)</sup>
D–	8	I/O	USB differential input/output minus <sup>(1)</sup>
DGND	6	—	Digital ground
DOUT	5	O	S/PDIF output
DT	3	I/O	Data input/output for external ROM (PCM 2704). Must be left open with pullup resistor (PCM2705). <sup>(1)</sup>
HID0/MS	22	I	HID key state input (mute), active HIGH (PCM2704). MS input (PCM2705). <sup>(2)</sup>
HID1/MC	23	I	HID key state input (volume up), active HIGH (PCM2704). MC input (PCM2705). <sup>(2)</sup>
HID2/MD	24	I	HID key state input (volume down), active HIGH (PCM2704). MD input (PCM2705). <sup>(2)</sup>
HOST	21	I	Host detection during self-powered operation (connect to V <sub>BUS</sub> ). Max power select during bus-powered operation (LOW: 100 mA, HIGH: 500 mA). <sup>(3)</sup>
PGND	19	—	Analog ground for DAC, OSC, and PLL
PSEL	4	I	Power source select (LOW: self-power, HIGH: bus-power) <sup>(1)</sup>
SSPND	27	O	Suspend flag, active LOW (LOW: suspend, HIGH: operational)
TEST0	26	I	Test pin. Must be set HIGH <sup>(1)</sup>
TEST1	25	I	Test pin. Must be set HIGH <sup>(1)</sup>
V <sub>BUS</sub>	10	—	Connect to USB power (V <sub>BUS</sub> ) for bus-powered operation. Connect to V <sub>DD</sub> for self-powered operation.
V <sub>CCL</sub>	13	—	Analog power supply for headphone amplifier of L-channel <sup>(4)</sup>
V <sub>CCP</sub>	20	—	Analog power supply for DAC, OSC, and PLL <sup>(4)</sup>
V <sub>CCR</sub>	16	—	Analog power supply for headphone amplifier of R-channel <sup>(4)</sup>
V <sub>COM</sub>	18	—	Common voltage for DAC (V <sub>CCP</sub> /2). Connect decoupling capacitor to PGND.
V <sub>DD</sub>	7	—	Digital power supply <sup>(4)</sup>
V <sub>OUTL</sub>	14	O	DAC analog output for L-channel
V <sub>OUTR</sub>	15	O	DAC analog output for R-channel
XTI	28	I	Crystal oscillator input <sup>(1)</sup>
XTO	1	O	Crystal oscillator output
ZGND	11	—	Ground for internal regulator

(1) LV-TTL level

(2) LV-TTL level with internal pulldown

(3) LV-TTL level, 5-V tolerant

(4) Connect decoupling capacitor to GND. Supply 3.3 V for self-powered applications.

**Terminal Functions (PCM2706PJT/PCM2707PJT)**

TERMINAL NAME	NO.	I/O	DESCRIPTION
AGNDL	26	—	Analog ground for headphone amplifier of L-channel
AGNDR	31	—	Analog ground for headphone amplifier of R-channel
CK	14	O	Clock output for external ROM (PCM2706). Must be left open (PCM2707).
D+	23	I/O	USB differential input/output plus <sup>(1)</sup>
D–	22	I/O	USB differential input/output minus <sup>(1)</sup>
DGND	20	—	Digital ground
DOUT	17	O	S/PDIF output/I <sup>2</sup> S™ data output
DT	15	I/O	Data input/output for external ROM (PCM2706). Must be left open with pullup resistor (PCM2707). <sup>(1)</sup>
FSEL	9	I	Function select (LOW: I <sup>2</sup> S DATA output, HIGH: S/PDIF output) <sup>(1)</sup>
FUNC0	5	I/O	HID key state input (next track), active HIGH (FSEL = 1). I <sup>2</sup> S LR clock output (FSEL = 0). <sup>(2)</sup>
FUNC1	19	I/O	HID key state input (previous track), active HIGH (FSEL = 1). I <sup>2</sup> S bit clock output (FSEL = 0). <sup>(2)</sup>
FUNC2	18	I/O	HID key state input (stop), active HIGH (FSEL = 1). I <sup>2</sup> S system clock output (FSEL = 0). <sup>(2)</sup>
FUNC3	4	I	HID key state input (play/pause), active HIGH (FSEL = 1). I <sup>2</sup> S data input (FSEL = 0). <sup>(2)</sup>
HID0/MS	6	I	HID key state input (mute), active HIGH (PCM2706). MS input (PCM2707) <sup>(2)</sup>
HID1/MC	7	I	HID key state input (volume up), active HIGH (PCM2706). MC input (PCM2707) <sup>(2)</sup>
HID2/MD	8	I	HID key state input (volume down), active HIGH (PCM2706). MD input (PCM2707) <sup>(2)</sup>
HOST	3	I	Host detection during self-powered operation (connect to V <sub>BUS</sub> ). Max power select during bus-powered operation. (LOW: 100 mA, HIGH: 500 mA). <sup>(3)</sup>
PGND	1	—	Analog ground for DAC, OSC, and PLL
PSEL	16	I	Power source select (LOW: self-power, HIGH: bus-power) <sup>(1)</sup>
SSPND	11	O	Suspend flag, active LOW (LOW: suspend, HIGH: operational)
TEST	10	I	Test pin. Must be set HIGH <sup>(1)</sup>
V <sub>BUS</sub>	24	—	Connect to USB power (V <sub>BUS</sub> ) for bus-powered operation. Connect to V <sub>DD</sub> for self-powered operation.
V <sub>CCL</sub>	27	—	Analog power supply for headphone amplifier of L-channel <sup>(4)</sup>
V <sub>CCP</sub>	2	—	Analog power supply for DAC, OSC, and PLL <sup>(4)</sup>
V <sub>CCR</sub>	30	—	Analog power supply for headphone amplifier of R-channel <sup>(4)</sup>
V <sub>COM</sub>	32	—	Common voltage for DAC (V <sub>CCP</sub> /2). Connect decoupling capacitor to PGND.
V <sub>DD</sub>	21	—	Digital power supply <sup>(4)</sup>
V <sub>OUTL</sub>	28	O	DAC analog output for L-channel
V <sub>OUTR</sub>	29	O	DAC analog output for R-channel
XTI	12	I	Crystal oscillator input <sup>(1)</sup>
XTO	13	O	Crystal oscillator output
ZGND	25	—	Ground for internal regulator

- (1) LV-TTL level
- (2) LV-TTL level with internal pulldown
- (3) LV-TTL level, 5-V tolerant
- (4) Connect decoupling capacitor to GND. Supply 3.3 V for self-powered applications.



BLOCK DIAGRAM (PCM2706PJT/PCM2707PJT)

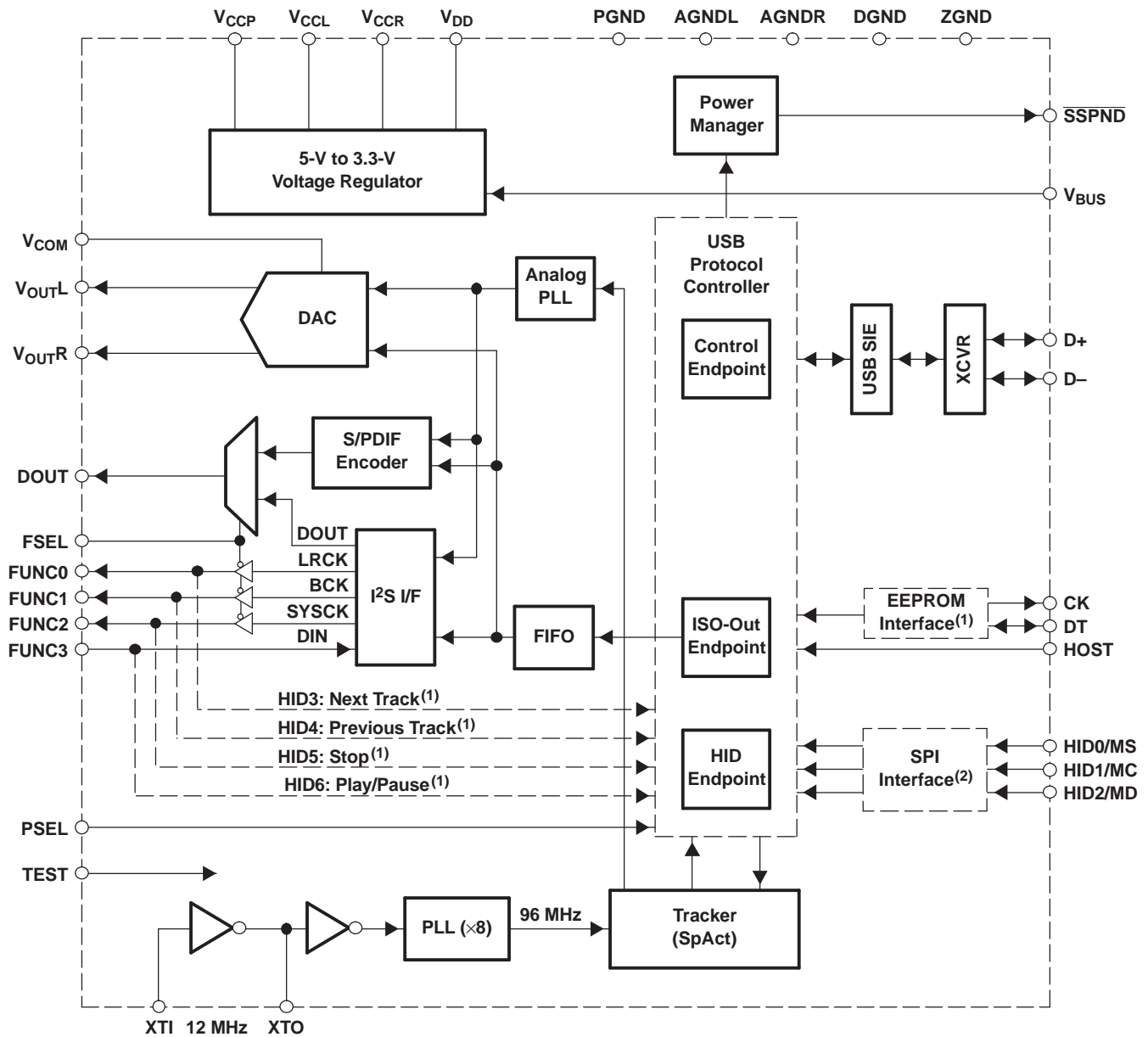

B0055-01

- (1) Applies to PCM2706PJT
- (2) Applies to PCM2707PJT

**TYPICAL PERFORMANCE CURVES OF INTERNAL FILTER**

All specifications at  $T_A = 25^\circ\text{C}$ ,  $V_{\text{BUS}} = 5\text{ V}$ ,  $f_S = 44.1\text{ kHz}$ ,  $f_{\text{IN}} = 1\text{ kHz}$ , 16-bit data (unless otherwise noted).

**DAC Digital Interpolation Filter Frequency Response**

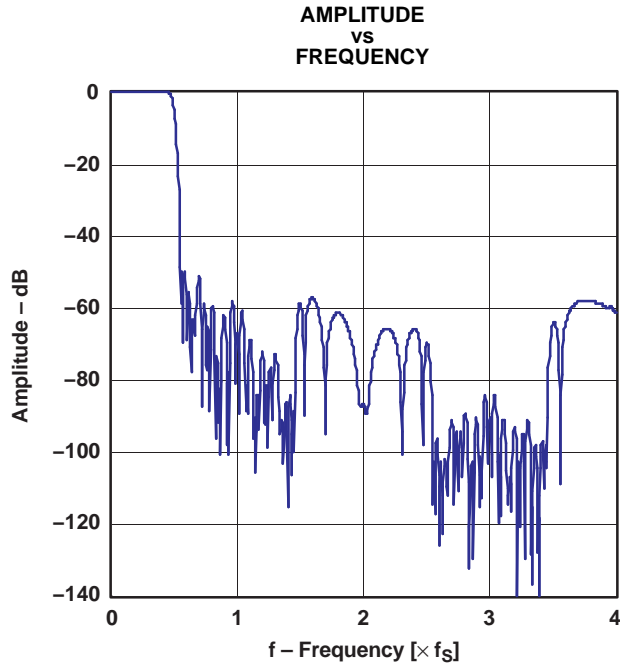

Figure 1. Frequency Response

G001

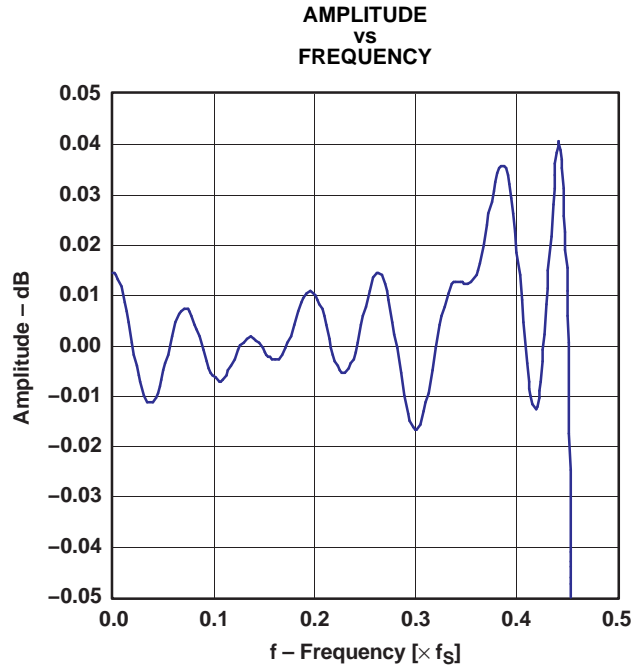

Figure 2. Pass-Band Ripple

G002

**DAC Analog Low-Pass Filter Frequency Response**

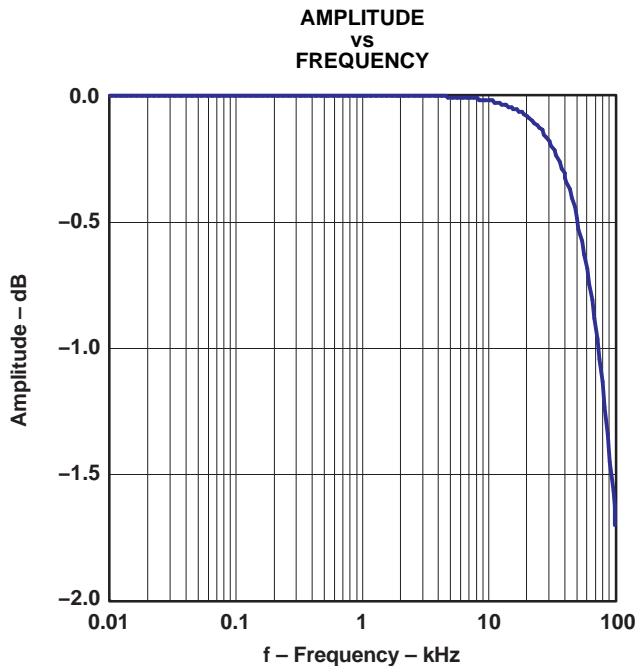

Figure 3. Pass-Band Characteristics

G003

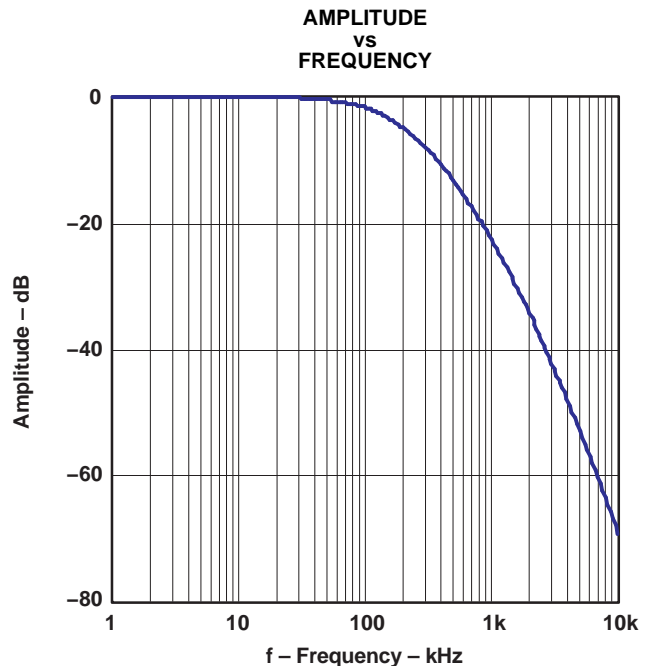

Figure 4. Stop-Band Characteristics

G004

### TYPICAL PERFORMANCE CURVES

All specifications at  $T_A = 25^\circ\text{C}$ ,  $V_{\text{BUS}} = 5\text{ V}$ ,  $f_s = 44.1\text{ kHz}$ ,  $f_{\text{IN}} = 1\text{ kHz}$ , 16-bit data (unless otherwise noted).

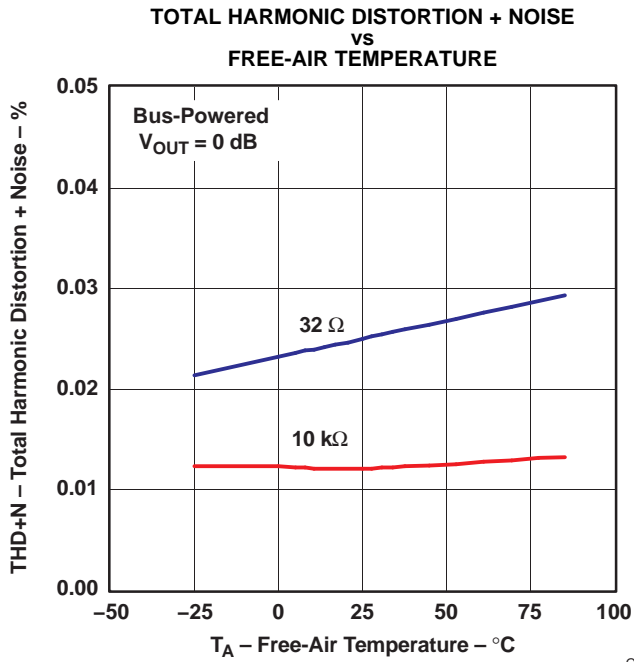

Figure 5.

G005

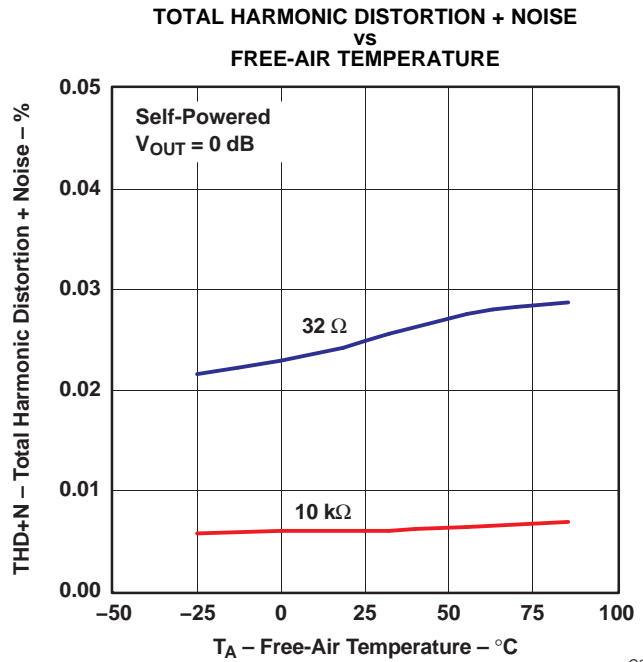

Figure 6.

G006

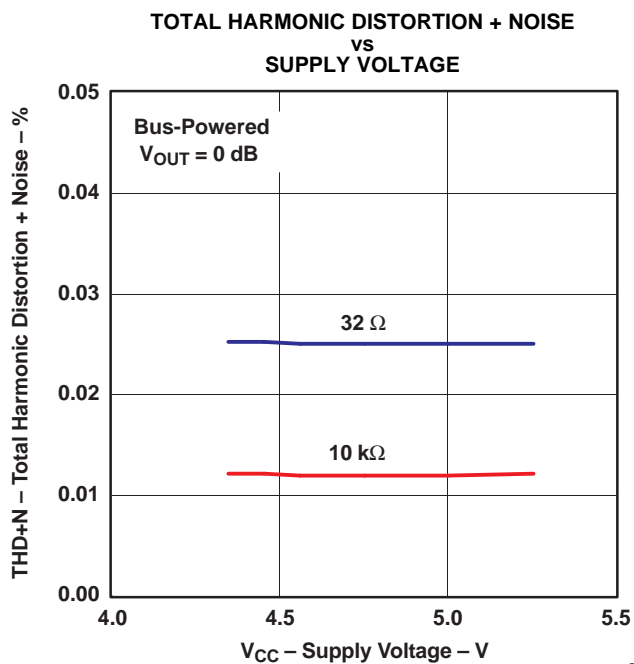

Figure 7.

G007

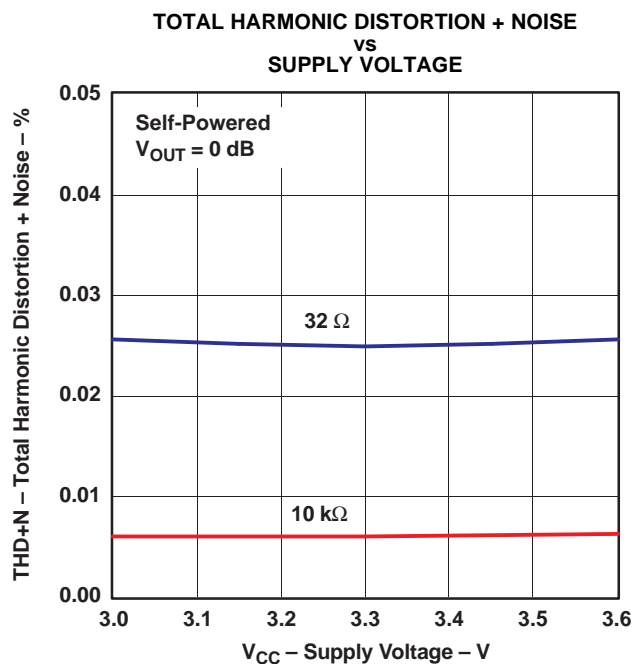

Figure 8.

G008

TYPICAL PERFORMANCE CURVES (continued)

All specifications at  $T_A = 25^\circ\text{C}$ ,  $V_{\text{BUS}} = 5\text{ V}$ ,  $f_S = 44.1\text{ kHz}$ ,  $f_{\text{IN}} = 1\text{ kHz}$ , 16-bit data (unless otherwise noted).

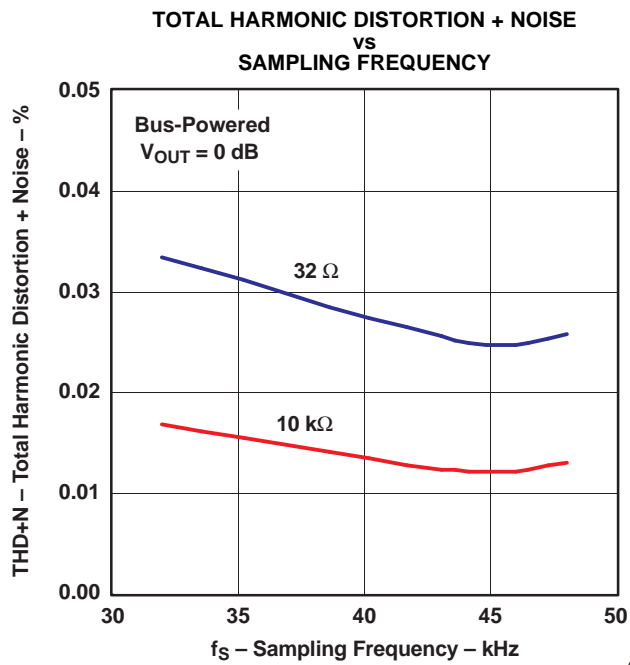

Figure 9.

G009

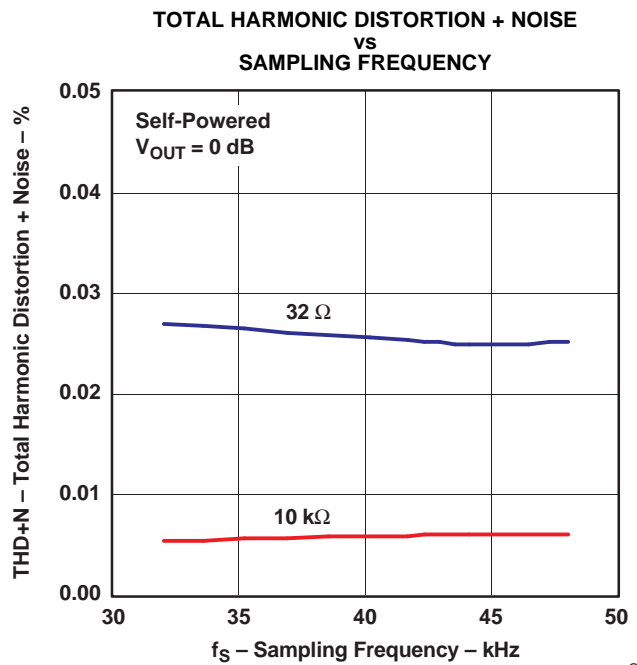

Figure 10.

G010

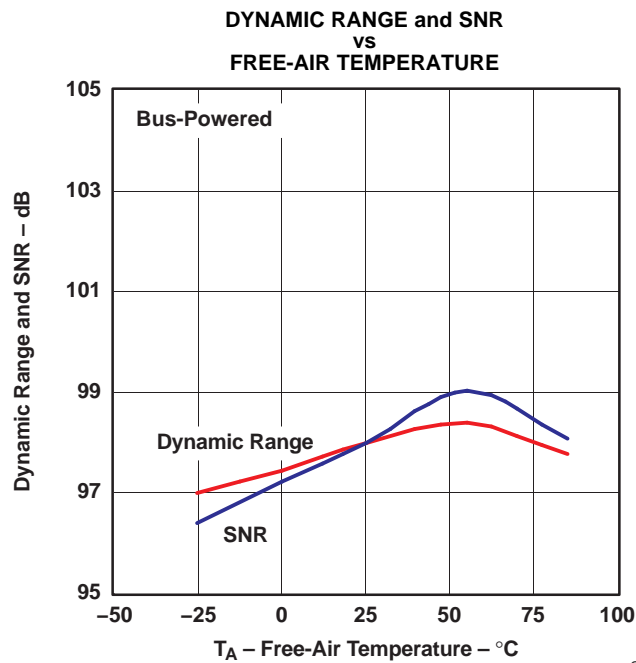

Figure 11.

G011

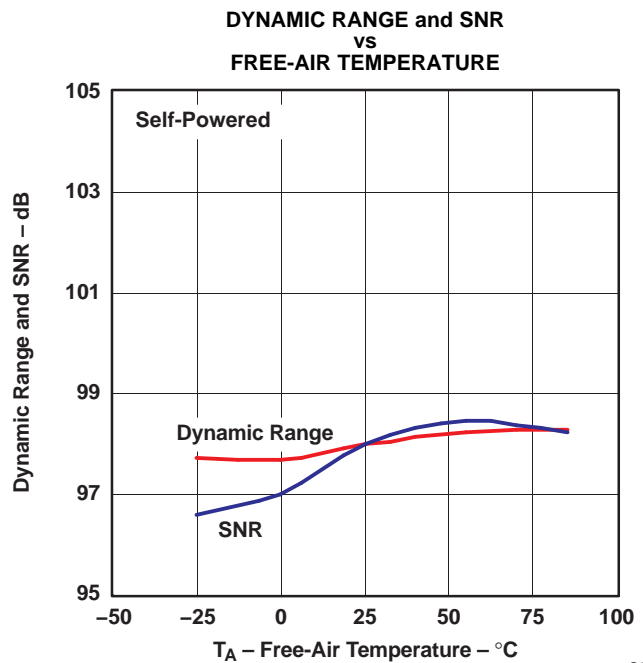

Figure 12.

G012

TYPICAL PERFORMANCE CURVES (continued)

All specifications at  $T_A = 25^\circ\text{C}$ ,  $V_{\text{BUS}} = 5\text{ V}$ ,  $f_S = 44.1\text{ kHz}$ ,  $f_{\text{IN}} = 1\text{ kHz}$ , 16-bit data (unless otherwise noted).

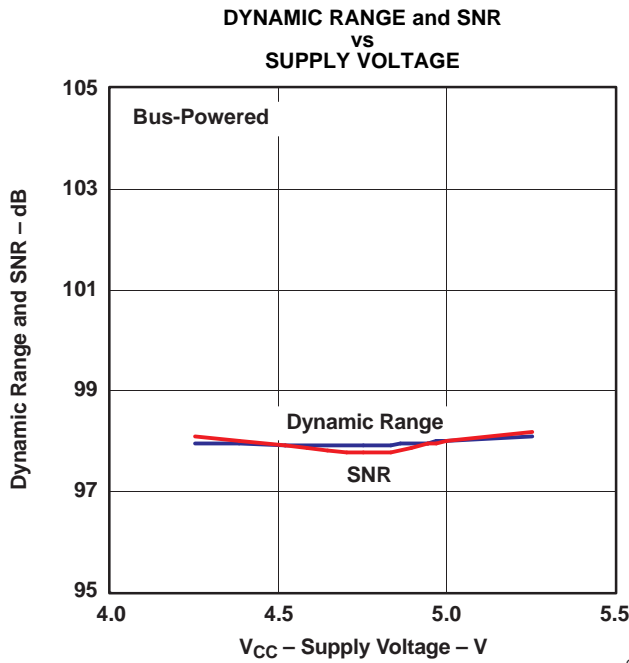

Figure 13.

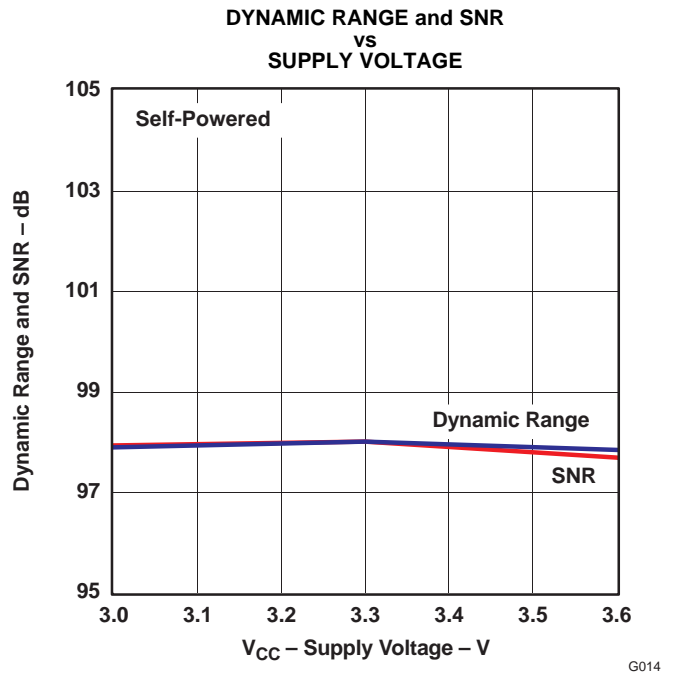

Figure 14.

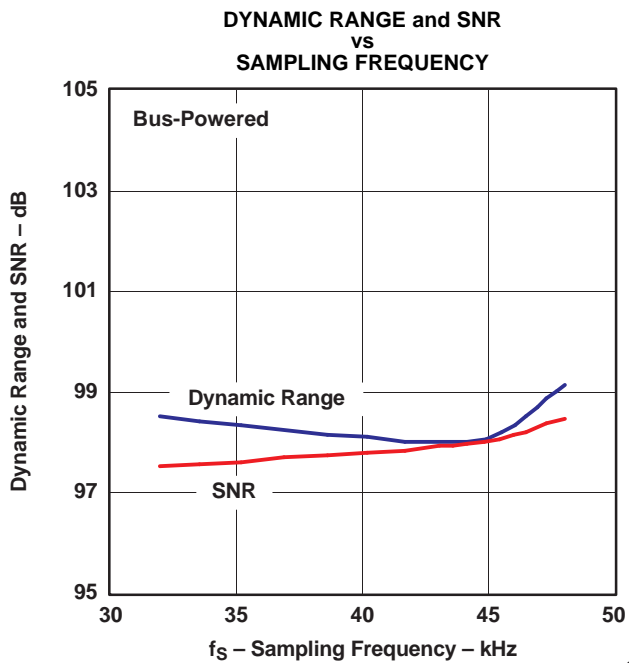

Figure 15.

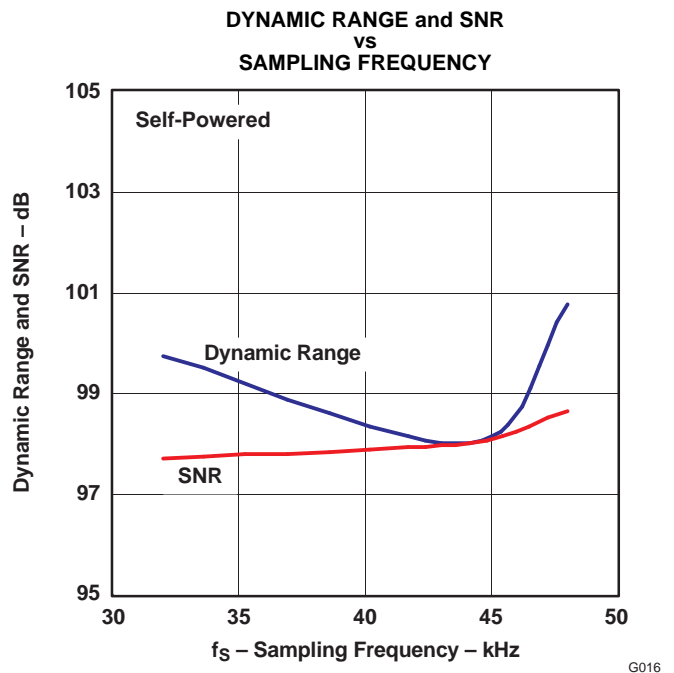

Figure 16.

**TYPICAL PERFORMANCE CURVES (continued)**

All specifications at  $T_A = 25^\circ\text{C}$ ,  $V_{\text{BUS}} = 5\text{ V}$ ,  $f_S = 44.1\text{ kHz}$ ,  $f_{\text{IN}} = 1\text{ kHz}$ , 16-bit data (unless otherwise noted).

**SUSPEND CURRENT  
vs  
SUPPLY VOLTAGE**

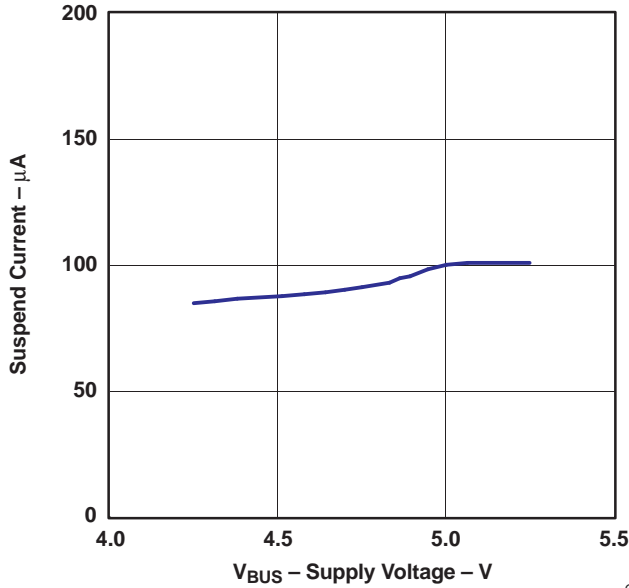

Figure 17.

G017

**SUSPEND CURRENT  
vs  
FREE-AIR TEMPERATURE**

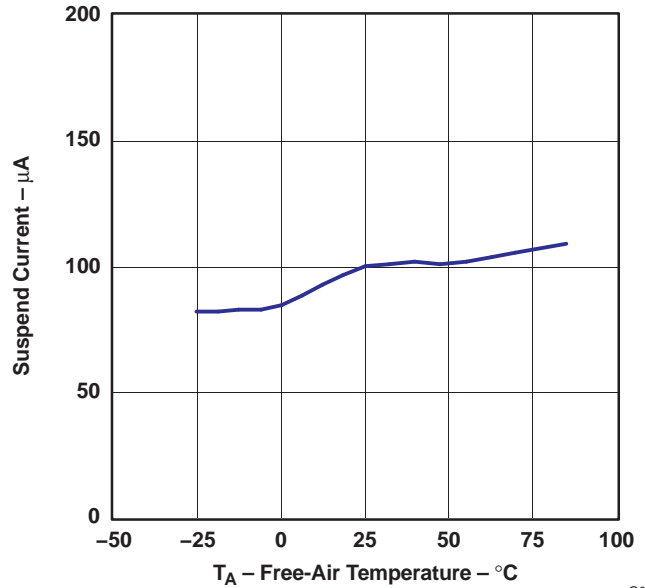

Figure 18.

G018

**AMPLITUDE  
vs  
FREQUENCY**

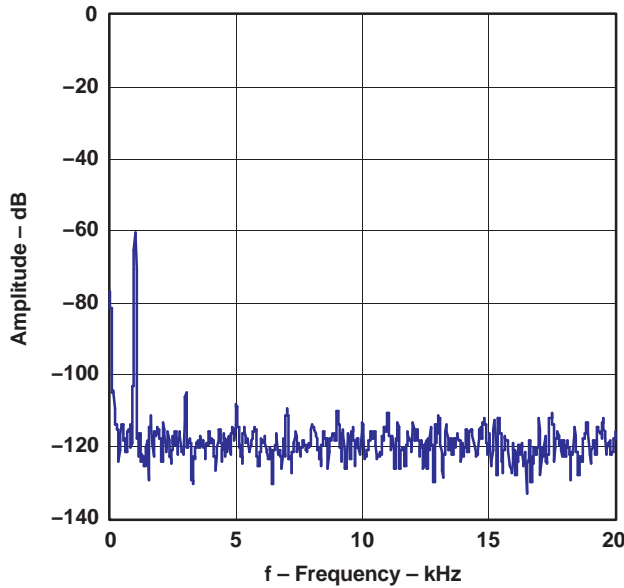

Figure 19. Output Spectrum (-60 dB, N = 8192)

G019

**AMPLITUDE  
vs  
FREQUENCY**

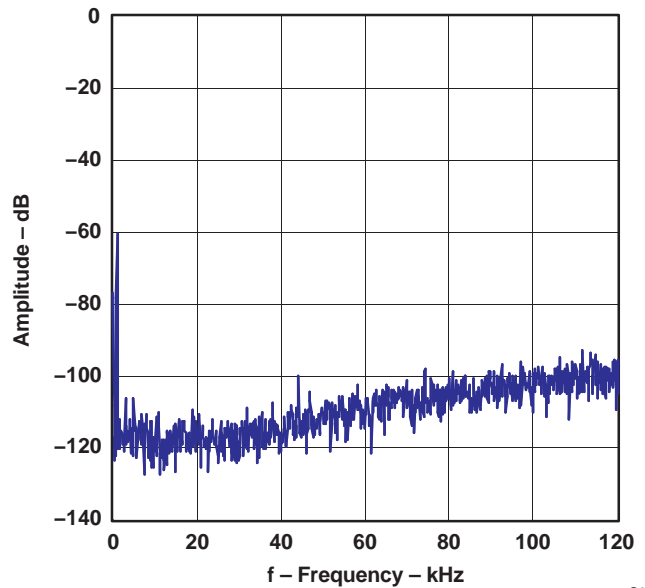

Figure 20. Output Spectrum (-60 dB, N = 8192)

G020

## DETAILED DESCRIPTION

### Clock and Reset

For both USB and audio functions, the PCM2704/5/6/7 requires a 12-MHz ( $\pm 500$  ppm) clock, which can be generated by the built-in oscillator using a 12-MHz crystal resonator. The 12-MHz crystal resonator must be connected to XTI (pin 28 for PCM2704/5, pin 12 for PCM2706/7) and XTO (pin 1 for PCM2704/5, pin 13 for PCM2706/7) with one large (1-M $\Omega$ ) resistor and two small capacitors, the capacitance of which depends on the specified load capacitance of the crystal resonator. An external clock can be supplied from XTI (pin 28 for PCM2704/5, pin 12 for PCM2706/7). If an external clock is supplied, XTO (pin 1 for PCM2704/5, pin 13 for PCM2706/7) must be left open. Because no clock disabling pin is provided, it is not recommended to use the external clock supply.  $\overline{\text{SSPND}}$  (pin 27 for PCM2704/5, pin 11 for PCM2706/7) is unable to use clock disabling.

The PCM2704/5/6/7 has an internal power-on reset circuit, and it works automatically when  $V_{\text{DD}}$  (pin 7 for PCM2704/5, pin 21 for PCM2706/7) exceeds 2 V typical (1.6 V–2.4 V), which is equivalent to  $V_{\text{BUS}}$  (pin 10 for PCM2704/5, pin 24 for PCM2706/7) exceeding 3 V typical for bus-powered applications. Approximately 700  $\mu\text{s}$  is required until internal reset release.

### Operation Mode Selection

The PCM2704/5/6/7 has the following mode-select pins.

#### Power Configuration Select/Host Detection

PSEL (pin 4 for PCM2704/5, pin 16 for PCM2706/7) is dedicated to selecting the power source. This selection affects the configuration descriptor. While in bus-powered operation, maximum power consumption from  $V_{\text{BUS}}$  is determined by HOST (pin 21 for PCM2704/5, pin 3 for PCM2706/7). For self-powered operation, HOST must be connected to  $V_{\text{BUS}}$  of the USB bus with a pulldown resistor to detect attach and detach. (To avoid excessive suspend current, the pulldown should be a high-value resistor.)

**Table 1. Power Configuration Select**

PSEL	DESCRIPTION
0	Self-powered
1	Bus-powered
HOST	DESCRIPTION
0	Detached from USB (self-powered)/100 mA (bus-powered)
1	Attached to USB (self-powered)/500 mA (bus-powered)

### Function Select (PCM2706/7)

FSEL (pin 9) determines the function of FUNC0–FUNC3 (pins 4, 5, 18, and 19) and DOUT (pin 17). When the I<sup>2</sup>S interface is required, FSEL must be set to LOW. Otherwise, FSEL must be set to HIGH.

**Table 2. Function Select**

FSEL	DOUT	FUNC0	FUNC1	FUNC2	FUNC3
0	Data out (I <sup>2</sup> S)	LRCK (I <sup>2</sup> S)	BCK (I <sup>2</sup> S)	SYSCK (I <sup>2</sup> S)	Data in (I <sup>2</sup> S)
1	S/PDIF data	Next track (HID) <sup>(1)</sup>	Previous track (HID) <sup>(1)</sup>	Stop (HID) <sup>(1)</sup>	Play/pause (HID) <sup>(1)</sup>

(1) Valid on the PCM2706; no function assigned on the PCM2707.

## USB Interface

Control data and audio data are transferred to the PCM2704/5/6/7 via D+ (pin 9 for PCM2704/5, pin 23 for PCM2706/7) and D– (pin 8 for PCM2704/5, pin 22 for PCM2706/7). D+ should be pulled up with a 1.5-kΩ (±5%) resistor. To avoid back voltage in self-powered operation, the device must not provide power to the pullup resistor on D+ while  $V_{BUS}$  of the USB port is inactive.

All data to/from the PCM2704/5/6/7 are transferred at full speed. The following information is provided in the device descriptor. Some parts of the device descriptor can be modified through external ROM (PCM2704/6), SPI (PCM2705/7), or internal mask ROM on request.

**Table 3. Device Descriptor**

DEVICE DESCRIPTOR	DESCRIPTION
USB revision	1.1 compliant
Device class	0x00 (device defined interface level)
Device subclass	0x00 (not specified)
Device protocol	0x00 (not specified)
Max packet size for endpoint 0	8 bytes
Vendor ID	0x08BB (default value, can be modified)
Product ID	0x2704/0x2705/0x2706/0x2707 (These values correspond to the model number, and the value can be modified.)
Device release number	1.0 (0x0100)
Number of configurations	1
Vendor strings	Burr-Brown from TI (default value, can be modified)
Product strings	USB Audio DAC (default value, can be modified)
Serial number	Not supported

The following information is contained in the configuration descriptor. Some parts of the configuration descriptor can be modified through external ROM (PCM2704/6), SPI (PCM2705/7), or internal mask ROM on request.

**Table 4. Configuration Descriptor**

CONFIGURATION DESCRIPTOR	DESCRIPTION
Interface	Three interfaces
Power attribute	0x80 or 0xC0 (bus-powered or self-powered, depending on PSEL; no remote wake up. This value can be modified.)
Max power	0x0A, 0x32 or 0xFA (20 mA for self-powered, 100 mA or 500 mA for bus-powered, depending on PSEL and HOST. This value can be modified.)

The following information is contained in the string descriptor. Some parts of the string descriptor can be modified through external ROM (PCM2704/6), SPI (PCM2705/7), or internal mask ROM on request.

**Table 5. String Descriptor**

STRING DESCRIPTOR	DESCRIPTION
#0	0x0409
#1	Burr-Brown from TI (default value, can be modified)
#2	USB Audio DAC (default value, can be modified)

## Device Configuration

Figure 21 illustrates the USB audio function topology. The PCM2704/5/6/7 has three interfaces. Each interface is enabled by some alternative settings.

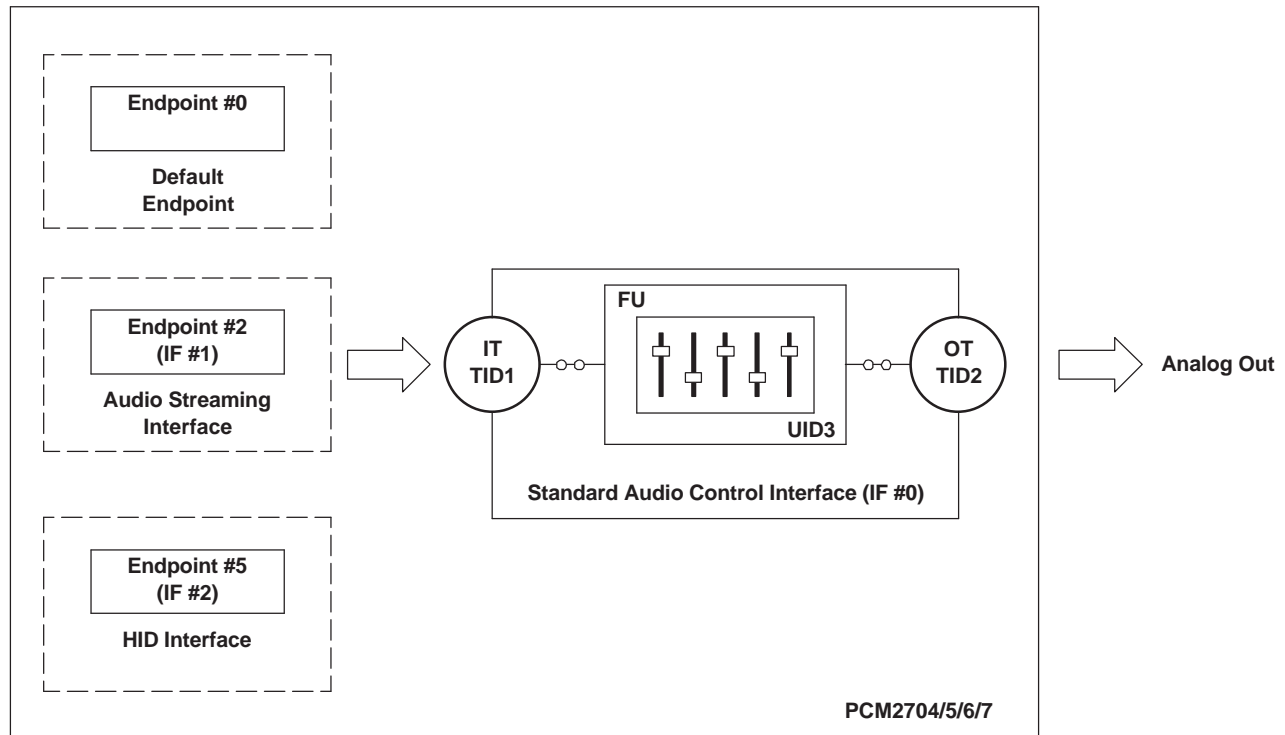

M0024-01

**Figure 21. USB Audio Function Topology**

### Interface #0 (Default/Control Interface)

Interface #0 is the control interface. Setting #0 is the only possible setting for interface #0. Setting #0 describes the standard audio control interface. Audio control interface consists of a terminal. The PCM2704/5/6/7 has three terminals:

- Input terminal (IT #1) for isochronous-out stream
- Output terminal (OT #2) for audio analog output
- Feature unit (FU #3) for DAC digital attenuator

Input terminal #1 is defined as a USB stream (terminal type 0x0101). Input terminal #1 can accept two-channel audio streams constructed of left and right channels. Output terminal #2 is defined as a speaker (terminal type 0x0301). Feature unit #3 supports the following sound control features:

- Volume control
- Mute control

The built-in digital volume controller can be manipulated by an audio-class-specific request from 0 dB to –64 dB in steps of 1 dB. Changes are made by incrementing or decrementing one step (1 dB) for every  $1/f_s$  time interval, until the volume level reaches the requested value. Each channel can be set to a separate value. The master volume control is not supported. A request to the master volume is stalled and ignored. The built-in digital mute controller can be manipulated by an audio-class-specific request. A master mute control request is acceptable. A mute control request to an individual channel is stalled and ignored. The digital volume control does not affect the S/PDIF and I<sup>2</sup>S outputs (PCM2706/7).

### Interface #1 (Isochronous-Out Interface)

Interface #1 is for the audio-streaming data-out interface. Interface #1 has the following three alternative settings. Alternative setting #0 is the zero-bandwidth setting. All other alternative settings are operational settings.

ALTERNATIVE SETTING	DATA FORMAT			TRANSFER MODE	SAMPLING RATE (kHz)
00	Zero bandwidth				
01	16-bit	Stereo	2s complement (PCM)	Adaptive	32, 44.1, 48
02	16-bit	Mono	2s complement (PCM)	Adaptive	32, 44.1, 48

### Interface #2 (HID Interface)

Interface #2 is the interrupt-data-in interface. Interface #2 comprises the HID consumer control device. Alternative setting #0 is the only possible setting for interface #2.

On the HID device descriptor, eight HID items are reported as follows for any model, in any configuration.

#### Basic HID Operation

Interface #2 can report the following three key statuses for any model. These statuses can be set by the HID0–HID2 pins (PCM2704/6) or the SPI port (PCM2705/7).

- Mute (0xE2)
- Volume up (0xE9)
- Volume down (0xEA)

#### Extended HID Operation (PCM2705/6/7)

By using the FUNC0–FUNC3 pins (PCM2706) or the SPI port (PCM2705/7), the following additional conditions can be reported to the host.

- Play/Pause (0xCD)
- Stop (0xB7)
- Previous (0xB6)
- Next (0xB5)

#### Auxiliary HID Status Report (PCM2705/7)

One additional HID status can be reported to the host through the SPI port. This status flag is defined by SPI command or external ROM. This definition must be described as on the report descriptor with a three-byte usage ID. *AL A/V Capture* (0x0193) is assigned as the default for this status flag.

### Endpoints

The PCM2704/5/6/7 has three endpoints:

- Control endpoint (EP #0)
- Isochronous-out audio data-stream endpoint (EP #2)
- HID endpoint (EP #5)

The control endpoint is a default endpoint. The control endpoint is used to control all functions of the PCM2704/5/6/7 by standard USB request and USB audio-class-specific request from the host. The isochronous-out audio data-stream endpoint is an audio sink endpoint that receives the PCM audio data. The isochronous-out audio data-stream endpoint accepts the adaptive transfer mode. The HID endpoint is an interrupt-in endpoint. The HID endpoint reports HID status every 10 ms.

The HID endpoint is defined as a consumer-control device. The HID function is designed as an independent endpoint from the isochronous-out endpoint. This means that the effect of HID operation depends on host software. Typically, the HID function is used to control the primary audio-out device.

## DAC

The PCM2704/5/6/7 has a DAC that uses an oversampling technique with  $128-f_s$  second-order multibit noise shaping. This technique provides extremely low quantization noise in the audio band, and the built-in analog low-pass filter removes the high-frequency components of the noise-shaping signal. DAC outputs through the headphone amplifier  $V_{OUTL}$  and  $V_{OUTR}$  can provide 12 mW at  $32 \Omega$ , as well as  $1.8 V_{PP}$  into a 10-k $\Omega$  load.

## Digital Audio Interface—S/PDIF Output

The PCM2704/5/6/7 employs S/PDIF output. Isochronous-out data from the host are encoded to S/PDIF output DOUT, as well as to DAC analog outputs  $V_{OUTL}$  and  $V_{OUTR}$ . Interface format and timing follow the IEC-60958 standard. Monaural data are converted to the stereo format at the same data rate. S/PDIF output is not supported in the I<sup>2</sup>S I/F enable mode. The implementation of this feature is optional. Note that it is your responsibility to determine whether to implement this feature in your product or not.

## Channel Status Information

The channel status information is fixed as consumer application, PCM mode, copyright, and digital/digital converter. All other bits are fixed as 0s, except for the sample frequency, which is set automatically according to the data received through the USB.

## Copyright Management

Digital audio data output always is encoded as original with SCMS control. Only one generation of digital duplication is allowed.

## Digital Audio Interface—I<sup>2</sup>S Interface Output (PCM2706/7)

The PCM2706 and PCM2707 can support the I<sup>2</sup>S interface, which is enabled by FSEL (pin 9). In the I<sup>2</sup>S interface enabled mode, pins 4, 18, 19, 5, and 17 are assigned as DIN, SYSCK, BCK, LRCK, and DOUT, respectively. They provide digital output/input data in the 16-bit I<sup>2</sup>S format, which also is accepted by the internal DAC. I<sup>2</sup>S interface format and timing are shown in Figure 22, Figure 23, and Figure 24.

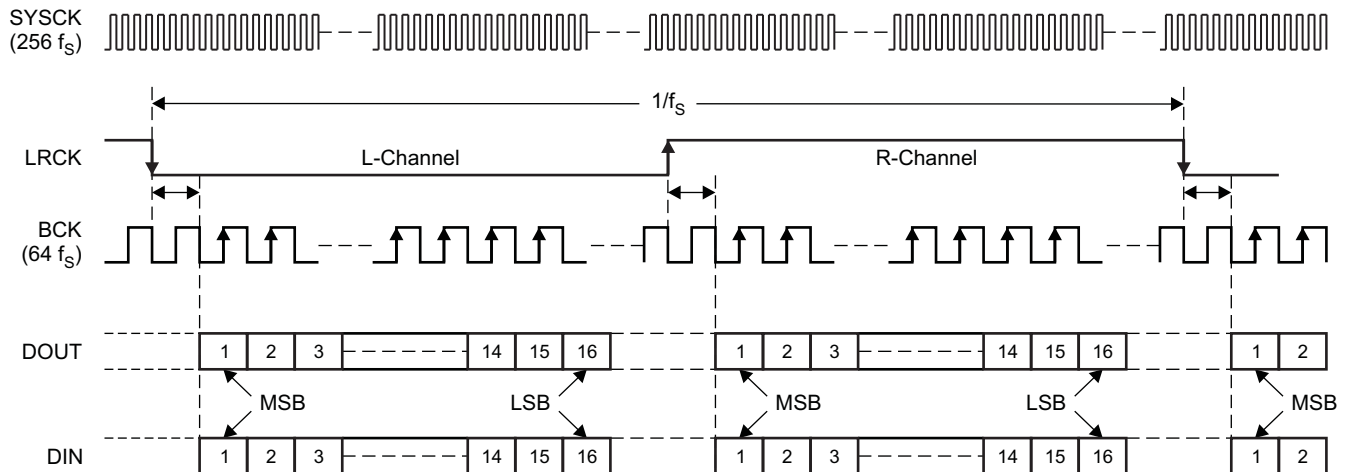

T0009-04

Figure 22. Audio Data Interface Format

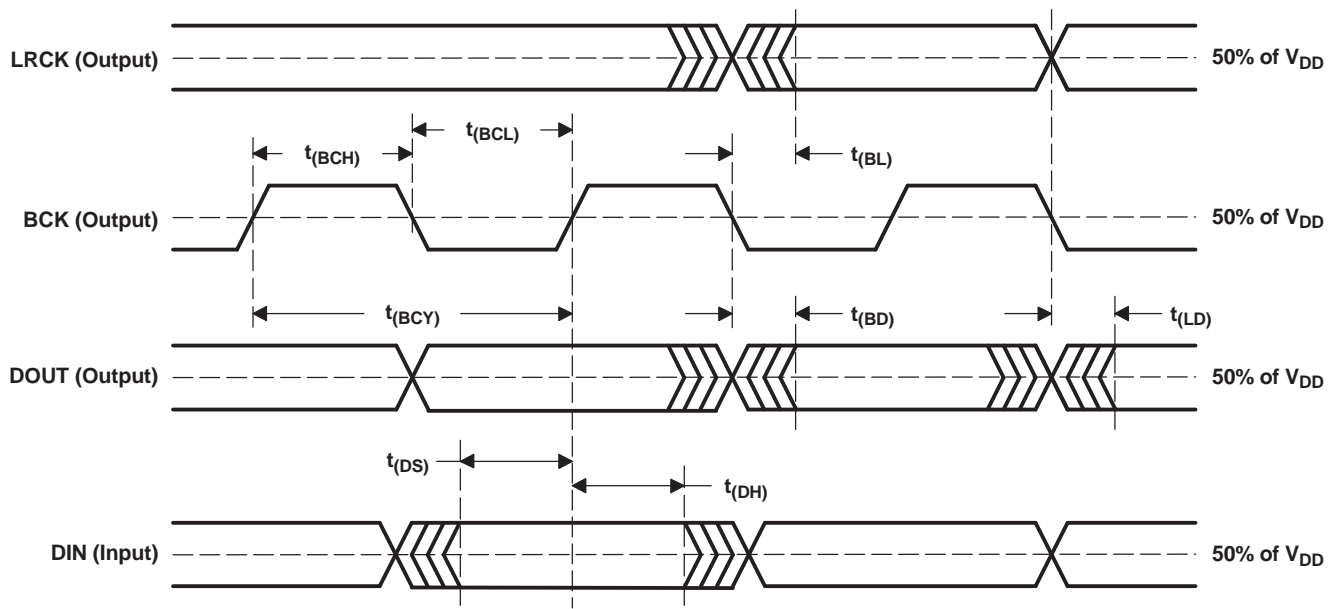

T0010-05

SYMBOL	PARAMETER	MIN	MAX	UNIT
$t_{(BCY)}$	BCK pulse cycle time	300		ns
$t_{(BCH)}$	BCK pulse duration, HIGH	100		ns
$t_{(BCL)}$	BCK pulse duration, LOW	100		ns
$t_{(BL)}$	LRCK delay time from BCK falling edge	-20	40	ns
$t_{(BD)}$	DOUT delay time from BCK falling edge	-20	40	ns
$t_{(LD)}$	DOUT delay time from LRCK edge	-20	40	ns
$t_{(DS)}$	DIN setup time	20		ns
$t_{(DH)}$	DIN hold time	20		ns

NOTE: Load capacitance of LRCK, BCK, and DOUT is 20 pF.

Figure 23. Audio Interface Timing

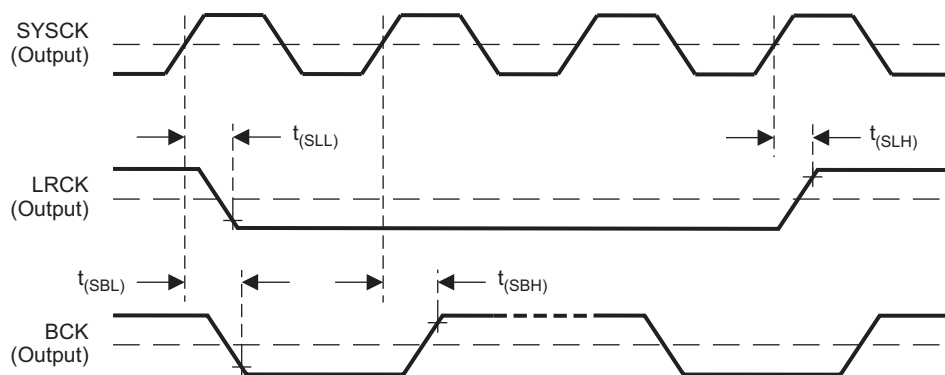

T0196-01

SYMBOL	PARAMETER	MIN	MAX	UNIT
$t_{(SLL)}, t_{(SLH)}$	LRCK delay time from SYSCK rising edge	-5	10	ns
$t_{(SBL)}, t_{(SBH)}$	BCK delay time from SYSCK rising edge	-5	10	ns

NOTE: Load capacitance is 20 pF.

Figure 24. Audio Clock Timing



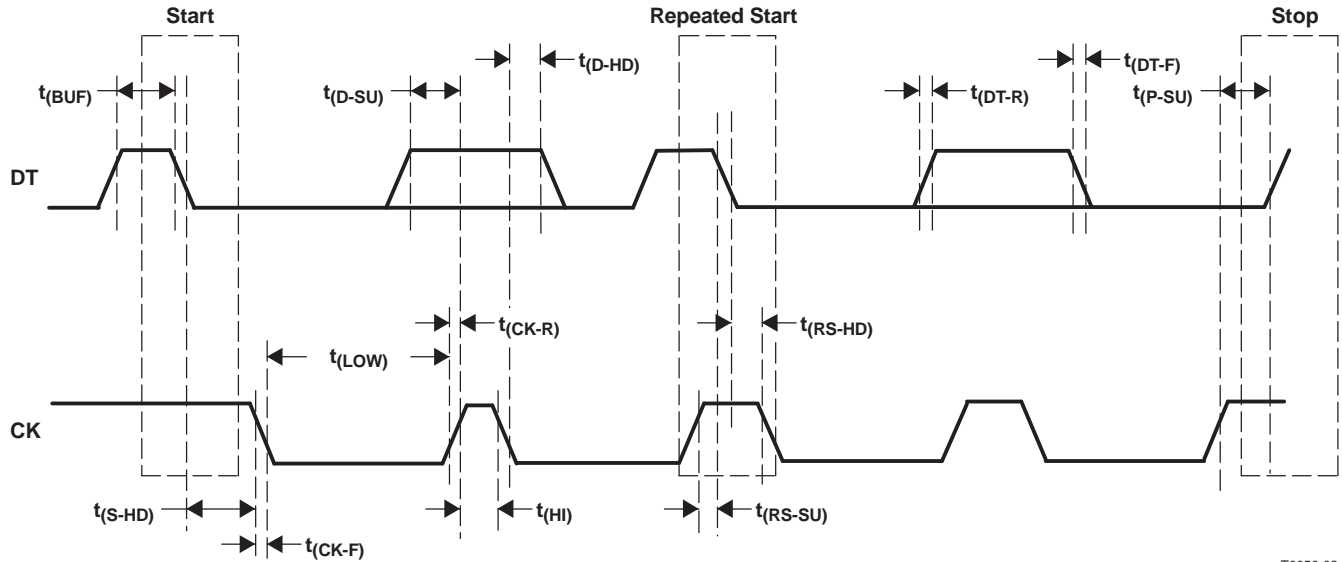

T0050-02

SYMBOL	PARAMETER	MIN	MAX	UNIT
$f_{(CK)}$	CK clock frequency		100	kHz
$t_{(BUF)}$	Bus free time between a STOP and a START condition	4.7		$\mu$ s
$t_{(LOW)}$	Low period of the CK clock	4.7		$\mu$ s
$t_{(HI)}$	High period of the CK clock	4		$\mu$ s
$t_{(RS-SU)}$	Setup time for START/repeated START condition	4.7		$\mu$ s
$t_{(S-HD)}$ $t_{(RS-HD)}$	Hold time for START/repeated START condition	4		$\mu$ s
$t_{(D-SU)}$	Data setup time	250		ns
$t_{(D-HD)}$	Data hold time	0	900	ns
$t_{(CK-R)}$	Rise time of CK signal	$20 + 0.1 C_B$	1000	ns
$t_{(CK-F)}$	Fall time of CK signal	$20 + 0.1 C_B$	1000	ns
$t_{(DT-R)}$	Rise time of DT signal	$20 + 0.1 C_B$	1000	ns
$t_{(DT-F)}$	Fall time of DT signal	$20 + 0.1 C_B$	1000	ns
$t_{(P-SU)}$	Setup time for STOP condition	4		$\mu$ s
$C_B$	Capacitive load for DT and CK lines		400	pF
$V_{NH}$	Noise margin at HIGH level for each connected device (including hysteresis)	$0.2 V_{DD}$		V

Figure 26. External ROM Read Interface Timing Requirements

## External ROM Example

Here is an example of external ROM data, with an explanation of the example following the data.

```
0xBB, 0x08, 0x04, 0x27,  
0x50, 0x72, 0x6F, 0x64, 0x75, 0x63, 0x74, 0x20, 0x73, 0x74, 0x72, 0x69, 0x6E, 0x67, 0x73, 0x2E,  
0x56, 0x65, 0x6E, 0x64, 0x6F, 0x72, 0x20, 0x73, 0x74, 0x72, 0x69, 0x6E, 0x67, 0x73, 0x20, 0x61,  
0x72, 0x65, 0x20, 0x70, 0x6C, 0x61, 0x63, 0x65, 0x64, 0x20, 0x68, 0x65, 0x72, 0x65, 0x2E, 0x20,  
0x80,  
0x7D,  
0x0A, 0x93, 0x01
```

The data are stored beginning at address 0x00.

Vendor ID: 0x08BB

Product ID: 0x2704

Product string: Product strings (16 bytes).

Vendor string: Vendor strings are placed here (32 bytes, 31 visible characters are followed by 1 space).

Power attribute (bmAttribute): 0x80 (Bus-powered).

Max power (maxPower): 0x7D (250 mA).

Auxiliary HID usage ID: 0x0A, 0x93, 0x01 (AL A/V capture).

Note that the data bits must be sent from LSB to MSB on the I<sup>2</sup>C bus. This means that each data byte must be stored with its bits in reverse order.

### Serial Programming Interface (PCM2705/7)

The PCM2705/7 supports the serial programming interface (SPI) to program the descriptor and to set the HID state. Descriptor data are described in the [SubSec 1 8.8 External ROM Descriptor](#) section.

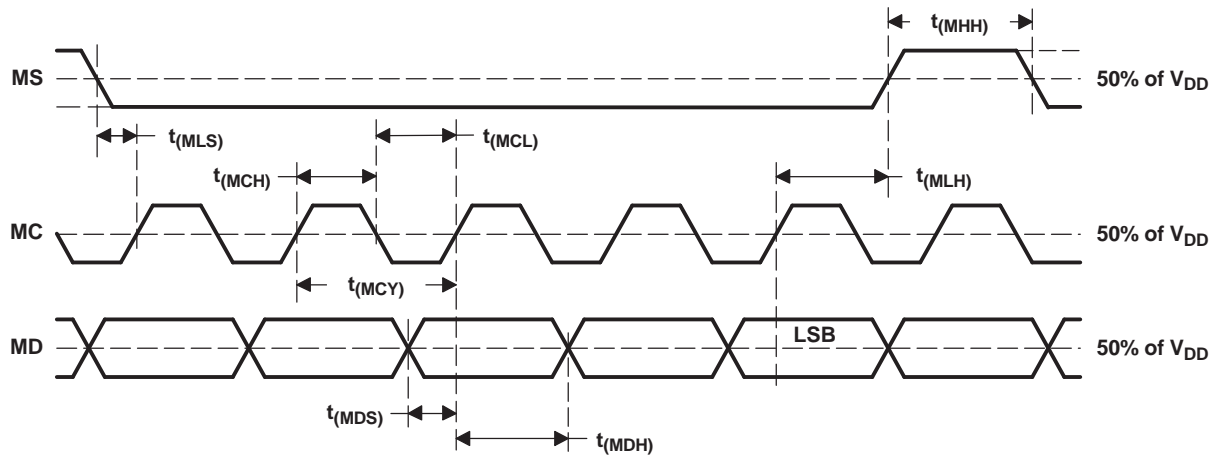

T0013-04

SYMBOL	PARAMETER	MIN	TYP	MAX	UNIT
t <sub>(MCY)</sub>	MC pulse cycle time	100			ns
t <sub>(MCL)</sub>	MC low-level time	50			ns
t <sub>(MCH)</sub>	MC high-level time	50			ns
t <sub>(MHH)</sub>	MS high-level time	100			ns
t <sub>(MLS)</sub>	MS falling edge to MC rising edge	20			ns
t <sub>(MLH)</sub>	MS hold time	20			ns
t <sub>(MDH)</sub>	MD hold time	15			ns
t <sub>(MDS)</sub>	MD setup time	20			ns

Figure 27. SPI Timing Diagram

#### (1) Single Write Operation

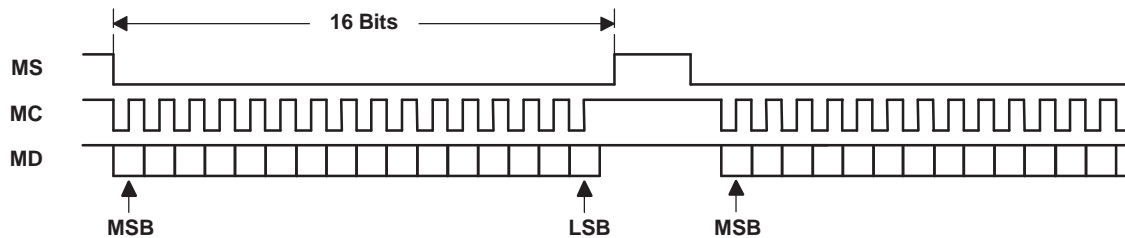

#### (2) Continuous Write Operation

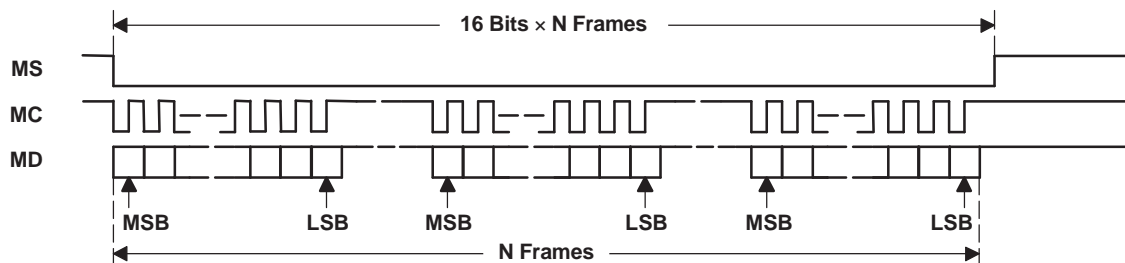

T0012-02

Figure 28. SPI Write Operation

**SPI Register (PCM2705/7)**

B15	B14	B13	B12	B11	B10	B9	B8	B7	B6	B5	B4	B3	B2	B1	B0
0	0	0	0	ST	0	ADDR	0	D0	D1	D2	D3	D4	D5	D6	D7

**D[7:0]**      **Function of the lower 8 bits depends on the value of the ST (B11) bit.**

ST = 0 (HID status write)

- D7 Reports MUTE HID status to the host (active high)
- D6 Reports volume-up HID status to the host (active high)
- D5 Reports volume-down HID status to the host (active high)
- D4 Reports next-track HID status to the host (active high)
- D3 Reports previous-track HID status to the host (active high)
- D2 Reports stop HID status to the host (active high)
- D1 Reports play/pause HID status to the host (active high)
- D0 Reports extended command status to the host (active high)

ST = 1 (ROM data write)

D[7:0] Internal descriptor ROM data, D0:LSB, D7:MSB

The content of power attribute and max power must be consistent with the actual application circuit configuration (PSEL setting and actual power usage from VBUS of USB connector); otherwise, it may cause improper or unexpected PCM2705/7 operation.

**ADDR**      **Starts write operation for internal descriptor reprogramming (active high)**

This bit resets descriptor ROM address counter and indicates following words should be ROM data (described in the *External ROM Example* section). 456 bits of ROM data must be continuously followed after this bit has been asserted. The data bits must be sent from LSB (D0) to MSB (D7).

To set ADDR high, ST must be set low. Note that the lower 8 bits are still active as an HID status write when ST is set low.

**ST**          **Determines the function of the lower 8-bit data as follows:**

- 0: HID status write
- 1: Descriptor ROM data write

**Table 6. Functionality of ST and ADDR Bit Combinations**

ST	ADDR	FUNCTION
0	0	HID status write
0	1	HID status write and descriptor ROM address reset
1	0	Descriptor ROM data write
1	1	Reserved

## USB Host Interface Sequence

### Power-On, Attach, and Playback Sequence

The PCM2704/5/6/7 is ready for setup when the reset sequence has finished and the USB bus is attached. After a connection has been established by setup, the PCM2704/5/6/7 is ready to accept USB audio data. While waiting for the audio data (idle state), the analog output is set to bipolar zero (BPZ).

When receiving the audio data, the PCM2704/5/6/7 stores the first audio packet, which contains 1 ms of audio data, into the internal storage buffer. The PCM2704/5/6/7 starts playing the audio data after detecting the next subsequent start-of-frame (SOF) packet.

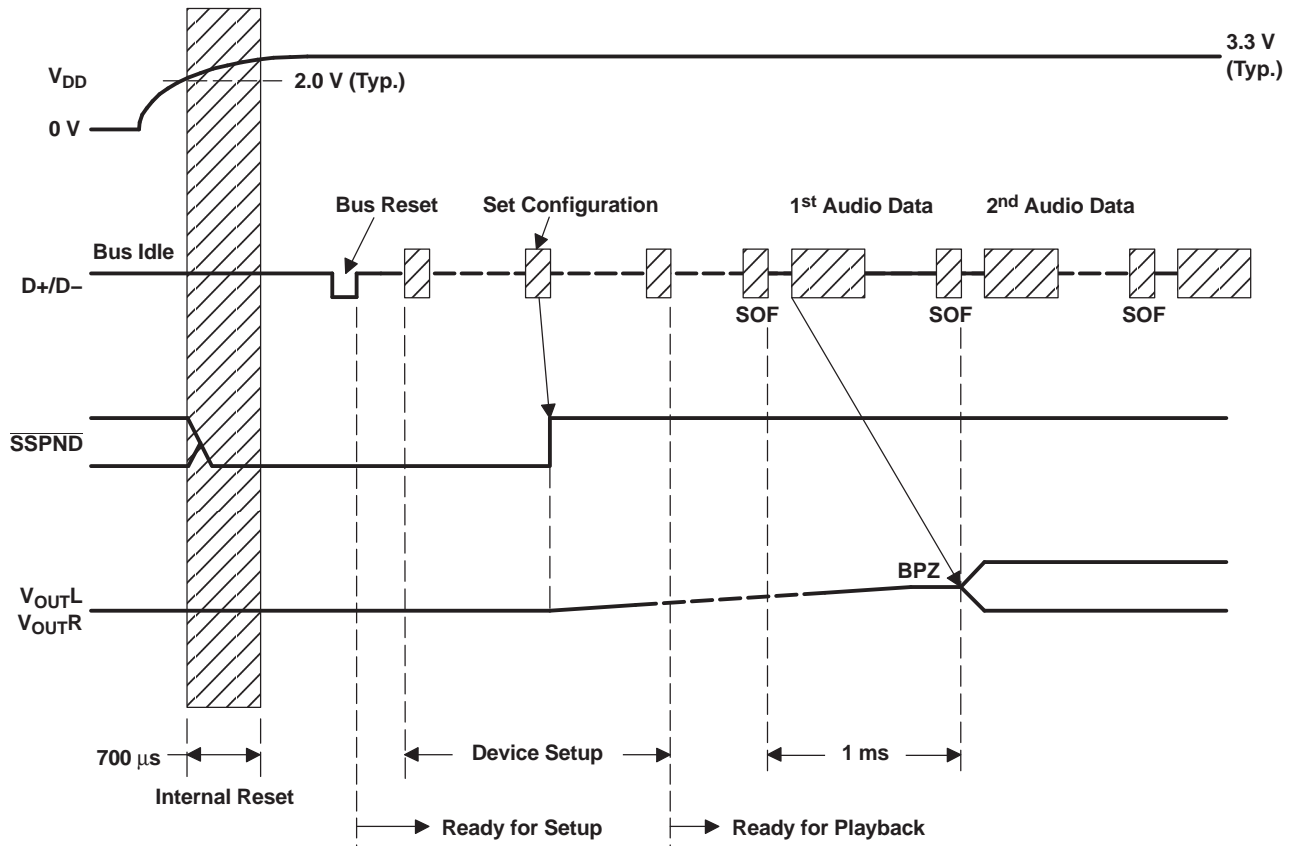

T0055-01

Figure 29. Initial Sequence

### Play, Stop, and Detach Sequence

When the host finishes or aborts the playback, the PCM2704/5/6/7 stops playing after completing the output of the last audio data.

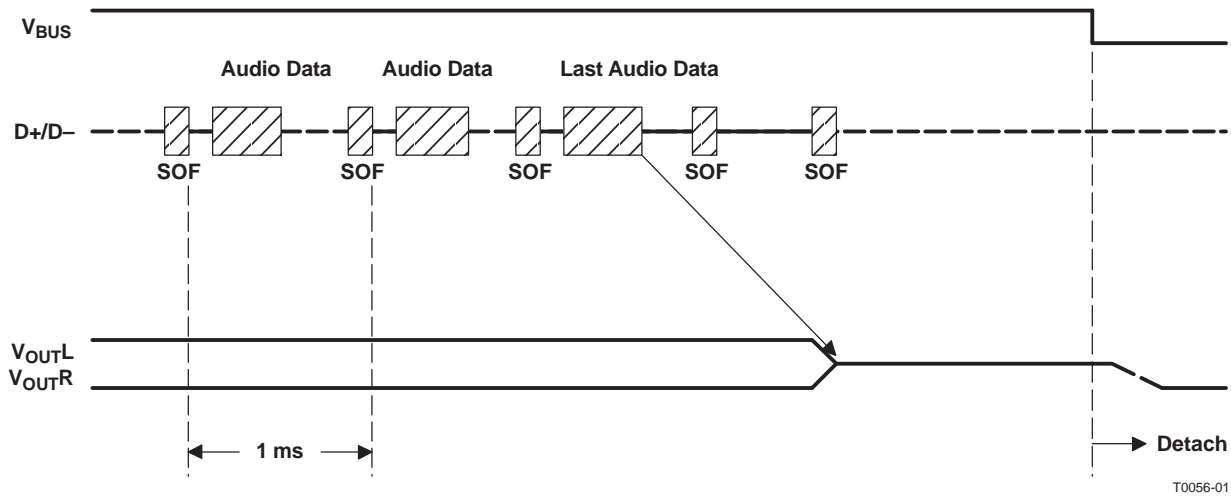

Figure 30. Play, Stop, and Detach

### Suspend and Resume Sequence

The PCM2704/5/6/7 enters the suspend state after the USB bus has been in a constant idle state for approximately 5 ms. While the PCM2704/5/6/7 is in the suspend state,  $\overline{SSPND}$  flag (pin 27 for PCM2704/5, pin 11 for PCM2706/7) is asserted. The PCM2704/5/6/7 wakes up immediately when detecting the non-idle state on the USB bus.

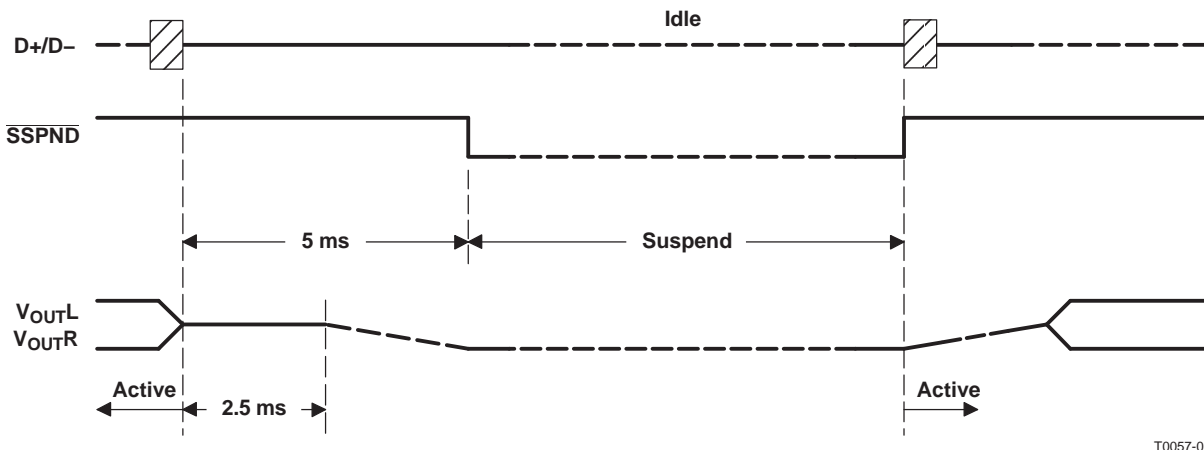
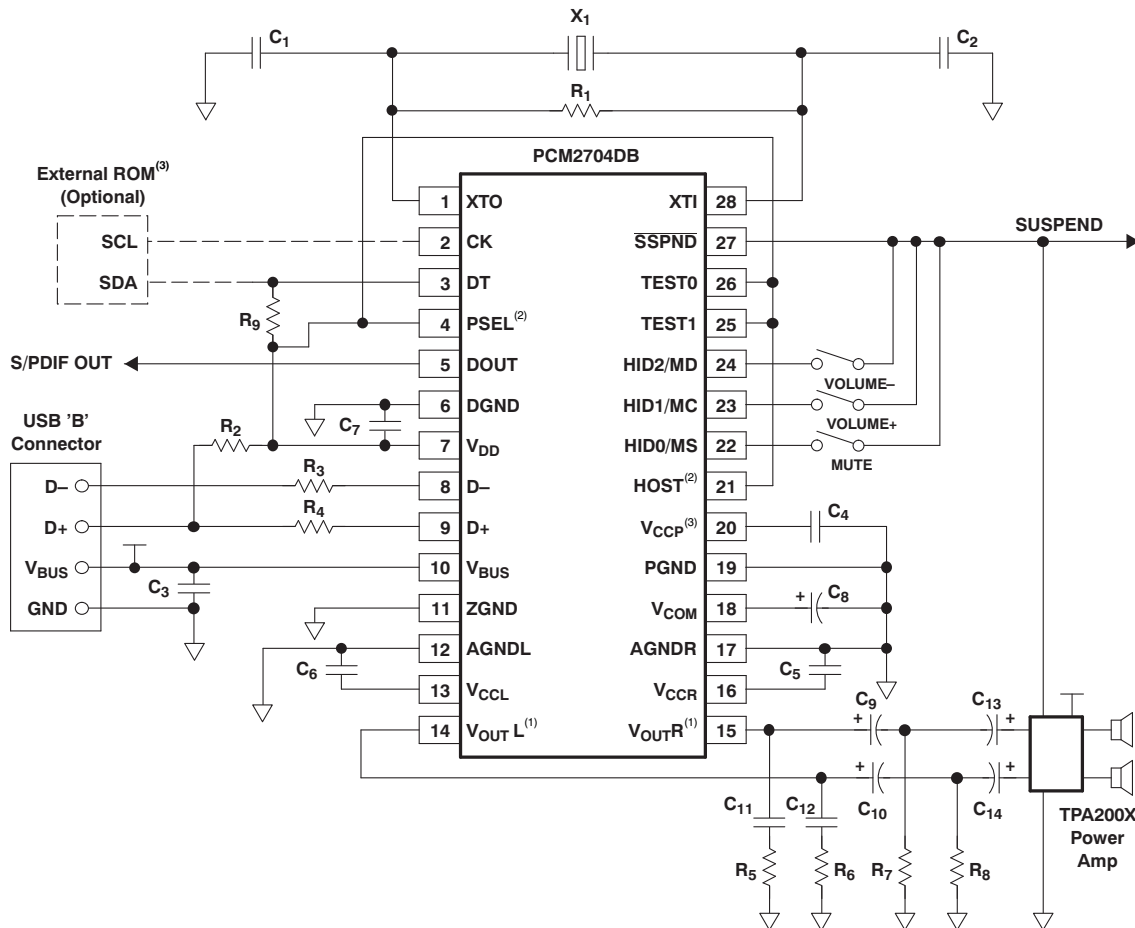

Figure 31. Suspend and Resume

### Typical Circuit Connection 1 (Example of USB Speaker)

Figure 32 illustrates a typical circuit connection for an internal-descriptor, bus-powered, 500-mA application.



NOTE: X<sub>1</sub>: 12-MHz crystal resonator. C<sub>1</sub>, C<sub>2</sub>: 10-pF to 33-pF capacitor (depending on load capacitance of crystal resonator). C<sub>3</sub>-C<sub>7</sub>: 1-μF ceramic capacitor. C<sub>8</sub>: 10-μF electrolytic capacitor. C<sub>9</sub>, C<sub>10</sub>: 100-μF electrolytic capacitor (depending on tradeoff between required frequency response and discharge time for resume). C<sub>11</sub>, C<sub>12</sub>: 0.022-μF ceramic capacitor. C<sub>13</sub>, C<sub>14</sub>: 1-μF electrolytic capacitor. R<sub>1</sub>: 1 MΩ resistor. R<sub>2</sub>, R<sub>9</sub>: 1.5 kΩ resistors. R<sub>3</sub>, R<sub>4</sub>: 22 Ω resistors. R<sub>5</sub>, R<sub>6</sub>: 16 Ω resistors. R<sub>7</sub>, R<sub>8</sub>: 330 Ω resistors (depending on tradeoff between required THD performance and pop-noise level for suspend).

(1) Output impedance of V<sub>OUTL</sub> and V<sub>OUTR</sub> during suspend mode or lack of power supply is 26 kΩ ±20%, which is the discharge path for C<sub>9</sub> and C<sub>10</sub>.

(2) Descriptor programming through external ROM is only available when PSEL and HOST are high.

(3) External ROM power can be supplied from V<sub>CCP</sub>, but any other active component must not use V<sub>CCP</sub>, V<sub>CCCL</sub>, V<sub>CCCR</sub>, or V<sub>DD</sub> as a power source.

Figure 32. Bus-Powered Application

**NOTE:**

The circuit illustrated in Figure 32 is for information only. The entire board design should be considered to meet the USB specification as a USB-compliant product.

### Typical Circuit Connection 2 (Example of Remote Headphone)

Figure 33 illustrates a typical circuit connection for a bus-powered, 100-mA headphone with seven HID.

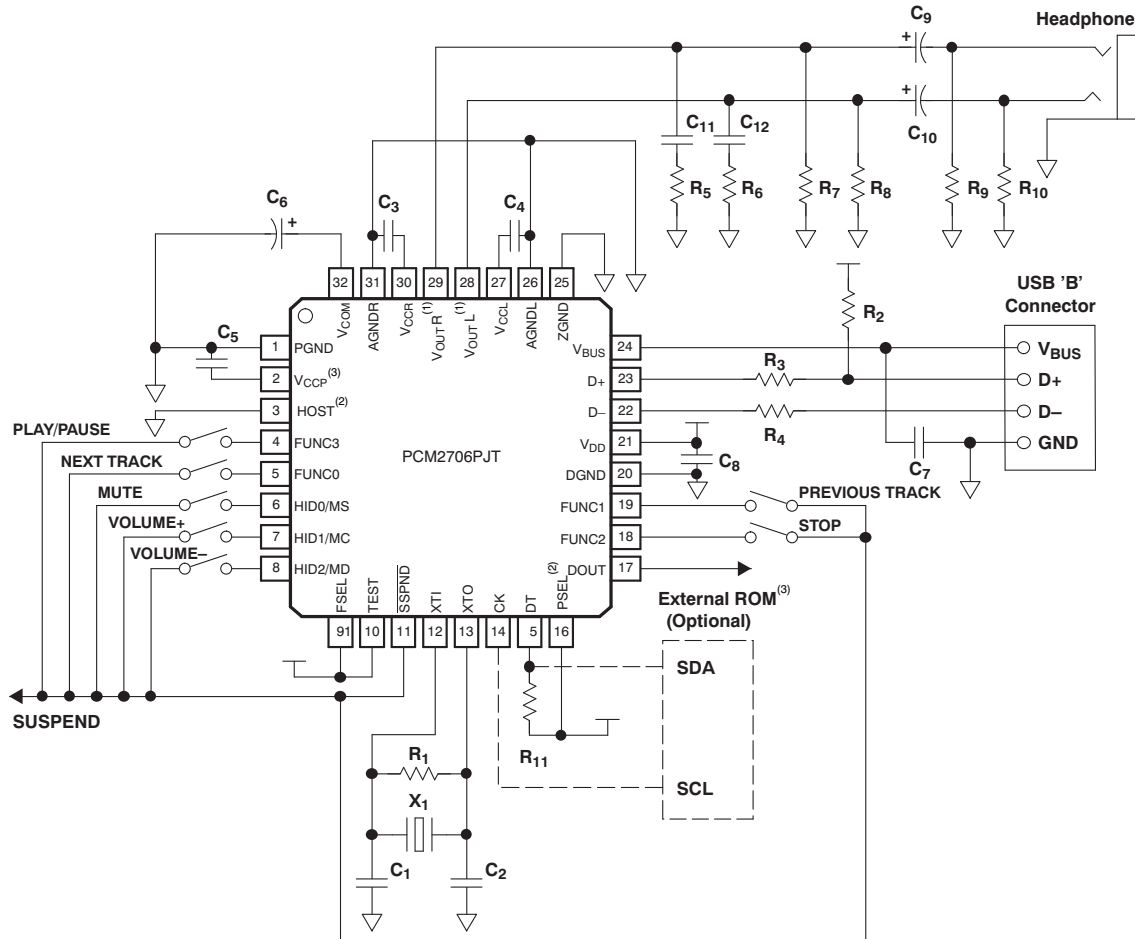

NOTE: X<sub>1</sub>: 12-MHz crystal resonator. C<sub>1</sub>, C<sub>2</sub>: 10-pF to 33-pF capacitors (depending on load capacitance of crystal resonator). C<sub>3</sub>-C<sub>5</sub>, C<sub>7</sub>, C<sub>8</sub>: 1-μF ceramic capacitors. C<sub>6</sub>: 10-μF electrolytic capacitor. C<sub>9</sub>, C<sub>10</sub>: 100-μF electrolytic capacitors (depending on required frequency response). C<sub>11</sub>, C<sub>12</sub>: 0.022-μF ceramic capacitors. R<sub>1</sub>: 1 MΩ resistor. R<sub>2</sub>, R<sub>11</sub>: 1.5 kΩ resistors. R<sub>3</sub>, R<sub>4</sub>: 22 Ω resistors. R<sub>5</sub>, R<sub>6</sub>: 16 Ω resistors. R<sub>7</sub>-R<sub>10</sub>: 3.3 kΩ resistors.

(1) Output impedance of V<sub>OUTL</sub> and V<sub>OUTR</sub> during suspend mode or lack of power supply is 26 kΩ ±20%, which is the discharge path for C<sub>9</sub> and C<sub>10</sub>.

(2) Descriptor programming through external ROM is only available when PSEL and HOST are high.

(3) External ROM power can be supplied from V<sub>CCP</sub>, but any other active component must not use V<sub>CCP</sub>, V<sub>CCCL</sub>, V<sub>CRR</sub>, or V<sub>DD</sub> as a power source.

Figure 33. Bus-Powered Application

**NOTE:**

The circuit illustrated in Figure 33 is for information only. The entire board design should be considered to meet the USB specification as a USB-compliant product.

### Typical Circuit Connection 3 (Example of DSP Surround Processing Amp)

Figure 34 illustrates a typical circuit connection for an I<sup>2</sup>S- and SPI-enabled self-powered application.

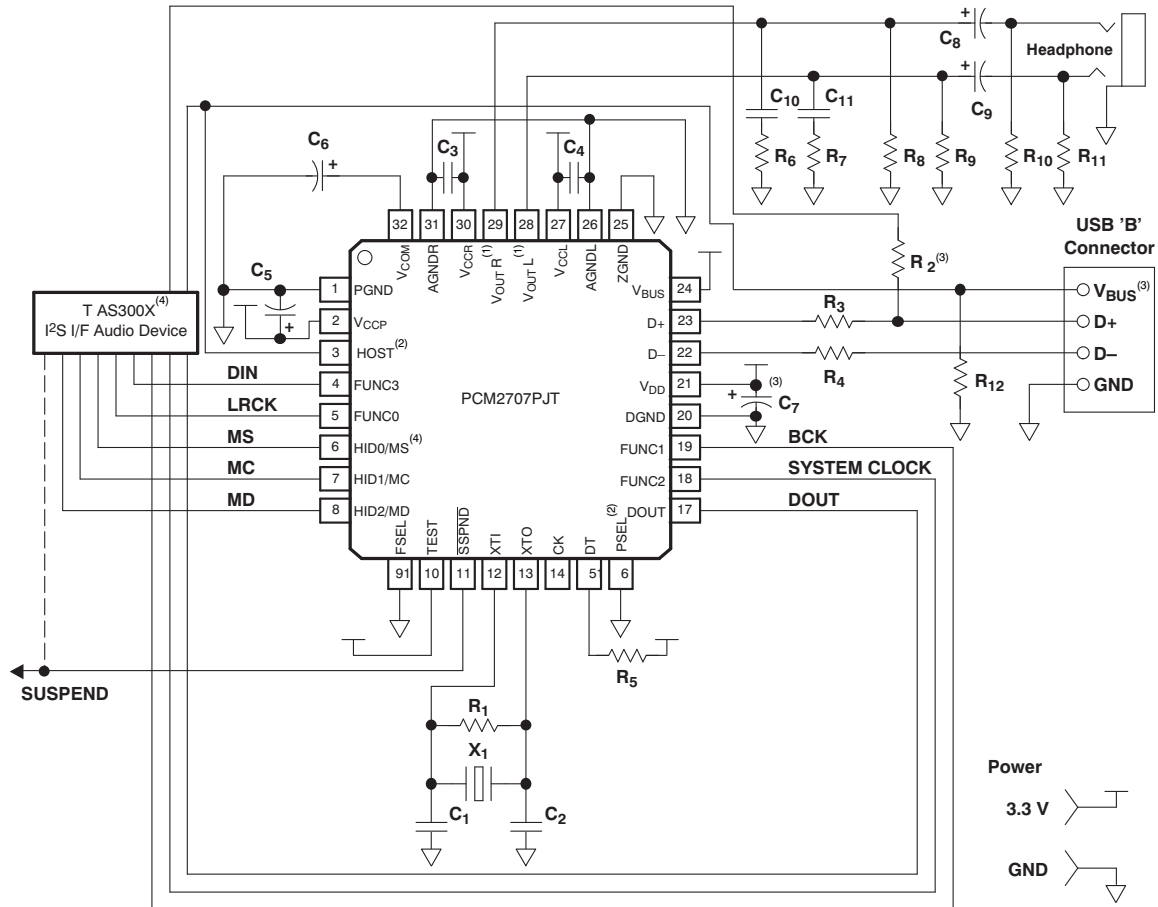

NOTE: X<sub>1</sub>: 12-MHz crystal resonator. C<sub>1</sub>, C<sub>2</sub>: 10-pF to 33-pF capacitors (depending on load capacitance of crystal resonator). C<sub>3</sub>, C<sub>4</sub>: 1-μF ceramic capacitors. C<sub>5</sub>, C<sub>7</sub>: 0.1-μF ceramic capacitor and 10-μF electrolytic capacitor. C<sub>6</sub>: 10-μF electrolytic capacitors. C<sub>8</sub>, C<sub>9</sub>: 100-μF electrolytic capacitors (depending on required frequency response). C<sub>10</sub>, C<sub>11</sub>: 0.022-μF ceramic capacitors. R<sub>1</sub>, R<sub>12</sub>: 1 MΩ resistors. R<sub>2</sub>, R<sub>5</sub>: 1.5 kΩ resistors. R<sub>3</sub>, R<sub>4</sub>: 22 Ω resistors. R<sub>6</sub>, R<sub>7</sub>: 16 Ω resistors. R<sub>8</sub>-R<sub>11</sub>: 3.3 kΩ resistors.

(1) Output impedance of V<sub>OUTL</sub> and V<sub>OUTR</sub> during suspend mode or lack of power supply is 26 kΩ ±20%, which is the discharge path for C<sub>8</sub> and C<sub>9</sub>.

(2) Descriptor programming through SPI is only available when PSEL and HOST are high.

(3) D+ pull-up must not be activated (HIGH: 3.3V) while the device is detached from USB or power supply is not applied on V<sub>DD</sub> and V<sub>CCX</sub>. VBUS of USB (5V) can be used to detect USB power status.

(4) MS must be high until the PCM2707 power supply is ready and the SPI host (DSP) is ready to send data. Also, the SPI host must handle the D+ pull-up if the descriptor is programmed through the SPI. D+ pull-up must not be activated (HIGH = 3.3 V) before programming of the PCM2707 through the SPI is complete.

Figure 34. Self-Powered Application

**NOTE:**

The circuit illustrated in Figure 34 is for information only. The entire board design should be considered to meet the USB specification as a USB-compliant product.

## APPENDIX

### Operating Environment

For current information on the PCM2704/2705/2706/2707 operating environment, see the *Updated Operating Environments for PCM270X, PCM290X Applications* application report, [SLAA374](#), available through the TI web site at [www.ti.com](http://www.ti.com).

## REVISION HISTORY

NOTE: Page numbers for previous revisions may differ from page numbers in the current version.

Changes from Revision E (November 2007) to Revision F	Page
• Added new feature .....	1
• Moved text to end of Digital Audio Interface-S/PDIF Output section.....	19
• Added Descriptor Data Modification paragraph.....	21
• Deleted <i>HOST</i> from list of circuit configuration terms.....	21
• Deleted <i>HOST</i> from list of circuit configuration terms.....	25
• Added notes to Figure 32, Figure 33, and Figure 34 for clarifying requirement of descriptor programing.....	28

Changes from Revision D (December 2006) to Revision E	Page
• Deleted operating environment information from data sheet and added reference to application report .....	31

**PACKAGING INFORMATION**

Orderable Device	Status (1)	Package Type	Package Drawing	Pins	Package Qty	Eco Plan (2)	Lead/Ball Finish (6)	MSL Peak Temp (3)	Op Temp (°C)	Device Marking (4/5)	Samples
PCM2704DB	NRND	SSOP	DB	28	47	Green (RoHS & no Sb/Br)	CU NIPDAU	Level-1-260C-UNLIM	-25 to 85	PCM2704	
PCM2704DBR	NRND	SSOP	DB	28	2000	Green (RoHS & no Sb/Br)	CU NIPDAU	Level-1-260C-UNLIM	-25 to 85	PCM2704	
PCM2704DBRG4	NRND	SSOP	DB	28	2000	Green (RoHS & no Sb/Br)	CU NIPDAU	Level-1-260C-UNLIM	-25 to 85	PCM2704	
PCM2705DB	NRND	SSOP	DB	28	50	Green (RoHS & no Sb/Br)	CU NIPDAU	Level-1-260C-UNLIM	-25 to 85	PCM2705	
PCM2705DBG4	NRND	SSOP	DB	28	50	Green (RoHS & no Sb/Br)	CU NIPDAU	Level-1-260C-UNLIM	-25 to 85	PCM2705	
PCM2705DBR	NRND	SSOP	DB	28	2000	Green (RoHS & no Sb/Br)	CU NIPDAU	Level-1-260C-UNLIM	-25 to 85	PCM2705	
PCM2706PJT	ACTIVE	TQFP	PJT	32	250	Green (RoHS & no Sb/Br)	CU NIPDAU	Level-1-260C-UNLIM	-25 to 85	PCM2706	<a href="#">Samples</a>
PCM2706PJTR	ACTIVE	TQFP	PJT	32	1000	Green (RoHS & no Sb/Br)	CU NIPDAU	Level-1-260C-UNLIM	-25 to 85	PCM2706	<a href="#">Samples</a>
PCM2707PJTG4	OBSOLETE	TQFP	PJT	32		Green (RoHS & no Sb/Br)	CU NIPDAU	Level-1-260C-UNLIM	0 to 0	PCM2707	
PCM2707PJTRG4	OBSOLETE	TQFP	PJT	32		Green (RoHS & no Sb/Br)	CU NIPDAU	Level-1-260C-UNLIM	0 to 0	PCM2707	

(1) The marketing status values are defined as follows:

**ACTIVE:** Product device recommended for new designs.

**LIFEBUY:** TI has announced that the device will be discontinued, and a lifetime-buy period is in effect.

**NRND:** Not recommended for new designs. Device is in production to support existing customers, but TI does not recommend using this part in a new design.

**PREVIEW:** Device has been announced but is not in production. Samples may or may not be available.

**OBSOLETE:** TI has discontinued the production of the device.

(2) **RoHS:** TI defines "RoHS" to mean semiconductor products that are compliant with the current EU RoHS requirements for all 10 RoHS substances, including the requirement that RoHS substance do not exceed 0.1% by weight in homogeneous materials. Where designed to be soldered at high temperatures, "RoHS" products are suitable for use in specified lead-free processes. TI may reference these types of products as "Pb-Free".

**RoHS Exempt:** TI defines "RoHS Exempt" to mean products that contain lead but are compliant with EU RoHS pursuant to a specific EU RoHS exemption.

**Green:** TI defines "Green" to mean the content of Chlorine (Cl) and Bromine (Br) based flame retardants meet JS709B low halogen requirements of <=1000ppm threshold. Antimony trioxide based flame retardants must also meet the <=1000ppm threshold requirement.

(3) MSL, Peak Temp. - The Moisture Sensitivity Level rating according to the JEDEC industry standard classifications, and peak solder temperature.

(4) There may be additional marking, which relates to the logo, the lot trace code information, or the environmental category on the device.

(5) Multiple Device Markings will be inside parentheses. Only one Device Marking contained in parentheses and separated by a "~" will appear on a device. If a line is indented then it is a continuation of the previous line and the two combined represent the entire Device Marking for that device.

(6) Lead/Ball Finish - Orderable Devices may have multiple material finish options. Finish options are separated by a vertical ruled line. Lead/Ball Finish values may wrap to two lines if the finish value exceeds the maximum column width.

**Important Information and Disclaimer:**The information provided on this page represents TI's knowledge and belief as of the date that it is provided. TI bases its knowledge and belief on information provided by third parties, and makes no representation or warranty as to the accuracy of such information. Efforts are underway to better integrate information from third parties. TI has taken and continues to take reasonable steps to provide representative and accurate information but may not have conducted destructive testing or chemical analysis on incoming materials and chemicals. TI and TI suppliers consider certain information to be proprietary, and thus CAS numbers and other limited information may not be available for release.

In no event shall TI's liability arising out of such information exceed the total purchase price of the TI part(s) at issue in this document sold by TI to Customer on an annual basis.

**TAPE AND REEL INFORMATION**

**QUADRANT ASSIGNMENTS FOR PIN 1 ORIENTATION IN TAPE**

\*All dimensions are nominal

Device	Package Type	Package Drawing	Pins	SPQ	Reel Diameter (mm)	Reel Width W1 (mm)	A0 (mm)	B0 (mm)	K0 (mm)	P1 (mm)	W (mm)	Pin1 Quadrant
PCM2704DBR	SSOP	DB	28	2000	330.0	17.4	8.5	10.8	2.4	12.0	16.0	Q1
PCM2705DBR	SSOP	DB	28	2000	330.0	16.4	8.2	10.5	2.5	12.0	16.0	Q1
PCM2706PJTR	TQFP	PJT	32	1000	330.0	16.8	9.6	9.6	1.5	12.0	16.0	Q2

**TAPE AND REEL BOX DIMENSIONS**

\*All dimensions are nominal

Device	Package Type	Package Drawing	Pins	SPQ	Length (mm)	Width (mm)	Height (mm)
PCM2704DBR	SSOP	DB	28	2000	336.6	336.6	28.6
PCM2705DBR	SSOP	DB	28	2000	367.0	367.0	38.0
PCM2706PJTR	TQFP	PJT	32	1000	367.0	367.0	38.0

# DB0028A



# PACKAGE OUTLINE

## SSOP - 2 mm max height

SMALL OUTLINE PACKAGE

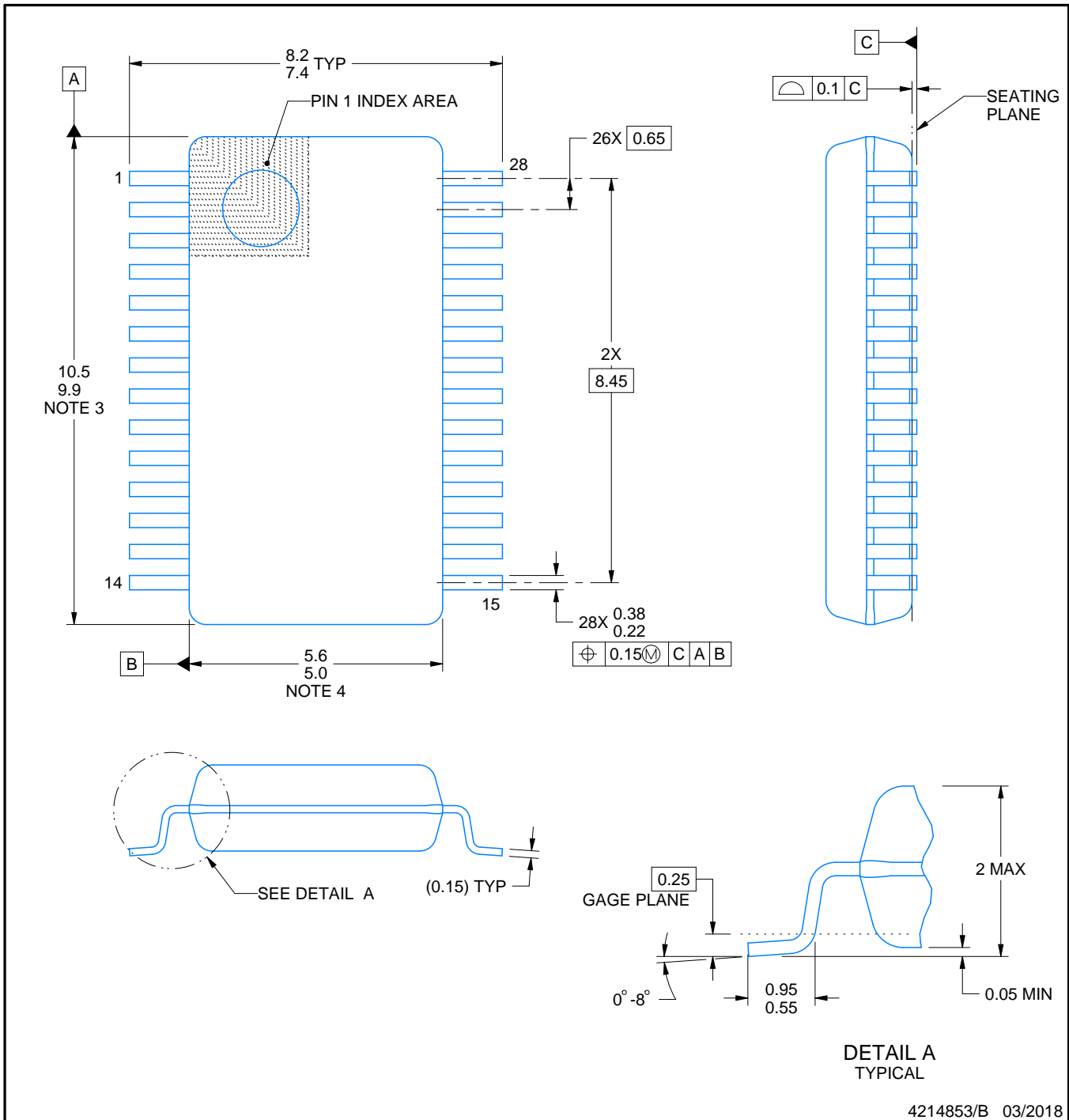

4214853/B 03/2018

### NOTES:

1. All linear dimensions are in millimeters. Any dimensions in parenthesis are for reference only. Dimensioning and tolerancing per ASME Y14.5M.
2. This drawing is subject to change without notice.
3. This dimension does not include mold flash, protrusions, or gate burrs. Mold flash, protrusions, or gate burrs shall not exceed 0.15 mm per side.
4. This dimension does not include interlead flash. Interlead flash shall not exceed 0.25 mm per side.
5. Reference JEDEC registration MO-150.

# EXAMPLE BOARD LAYOUT

DB0028A

SSOP - 2 mm max height

SMALL OUTLINE PACKAGE

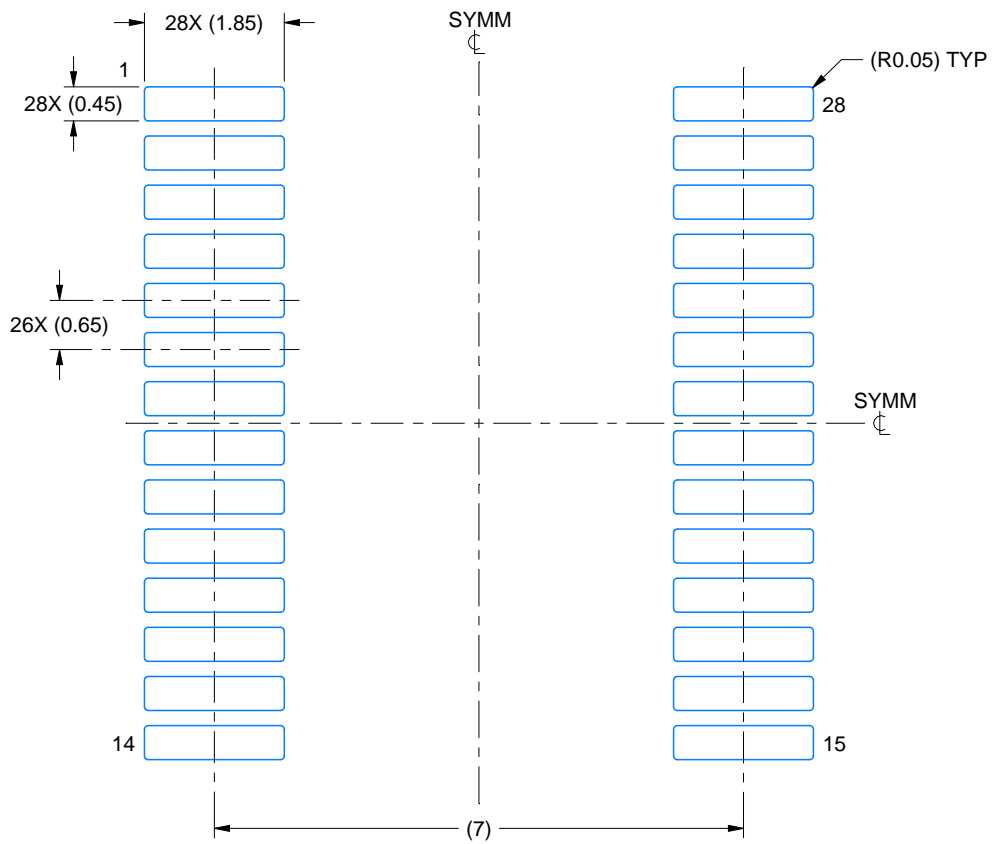

LAND PATTERN EXAMPLE  
EXPOSED METAL SHOWN  
SCALE: 10X

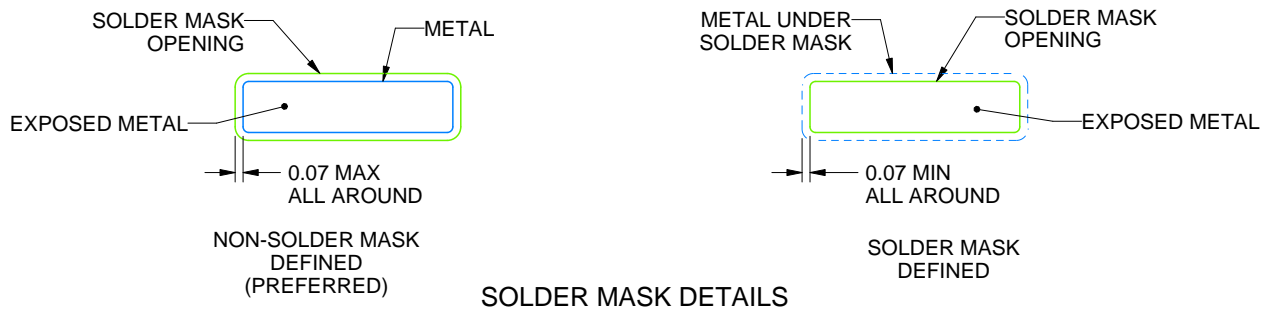

4214853/B 03/2018

NOTES: (continued)

- 6. Publication IPC-7351 may have alternate designs.
- 7. Solder mask tolerances between and around signal pads can vary based on board fabrication site.

# EXAMPLE STENCIL DESIGN

DB0028A

SSOP - 2 mm max height

SMALL OUTLINE PACKAGE

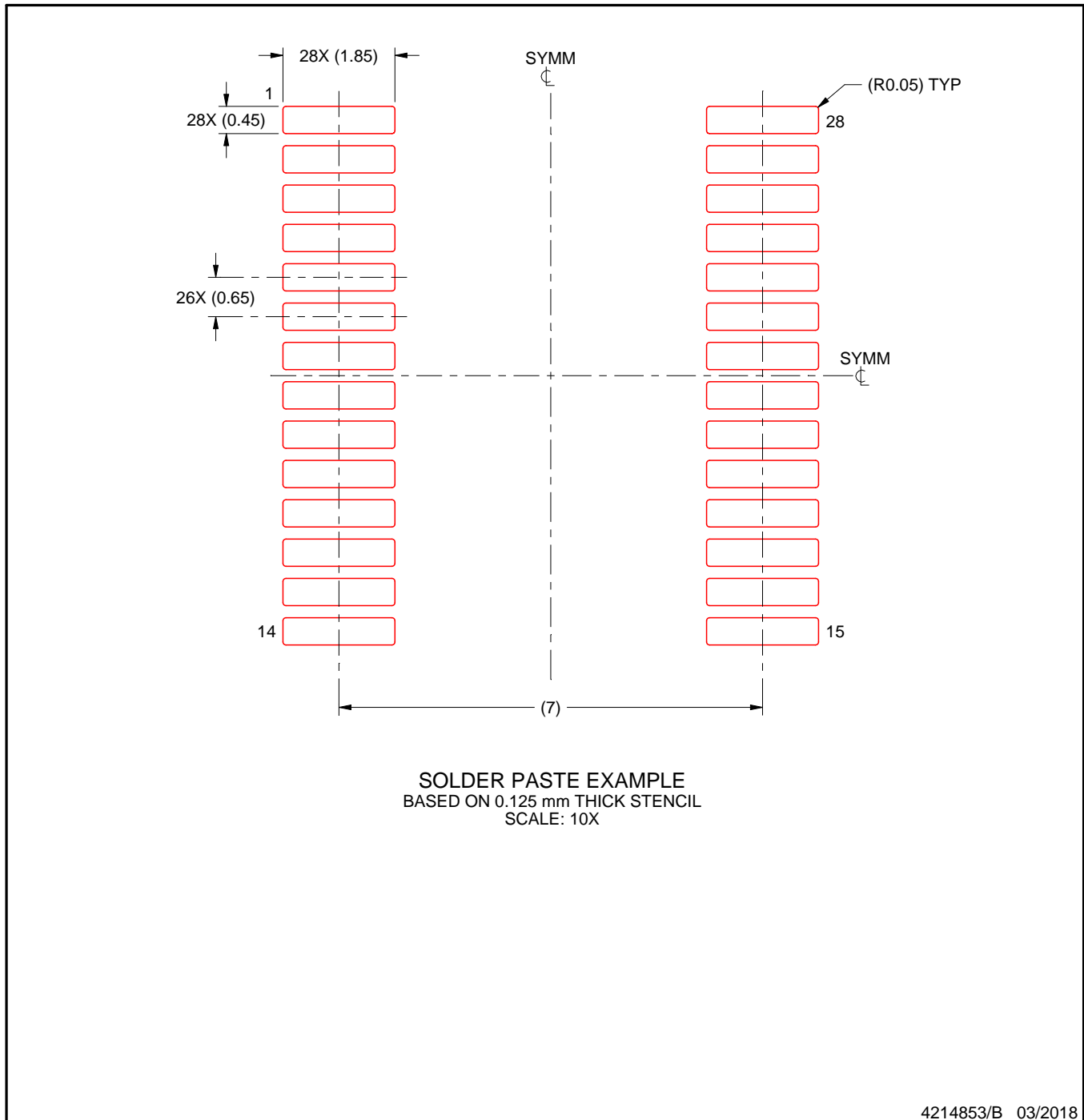

NOTES: (continued)

8. Laser cutting apertures with trapezoidal walls and rounded corners may offer better paste release. IPC-7525 may have alternate design recommendations.
9. Board assembly site may have different recommendations for stencil design.

PJT (S-PQFP-N32)

PLASTIC QUAD FLATPACK

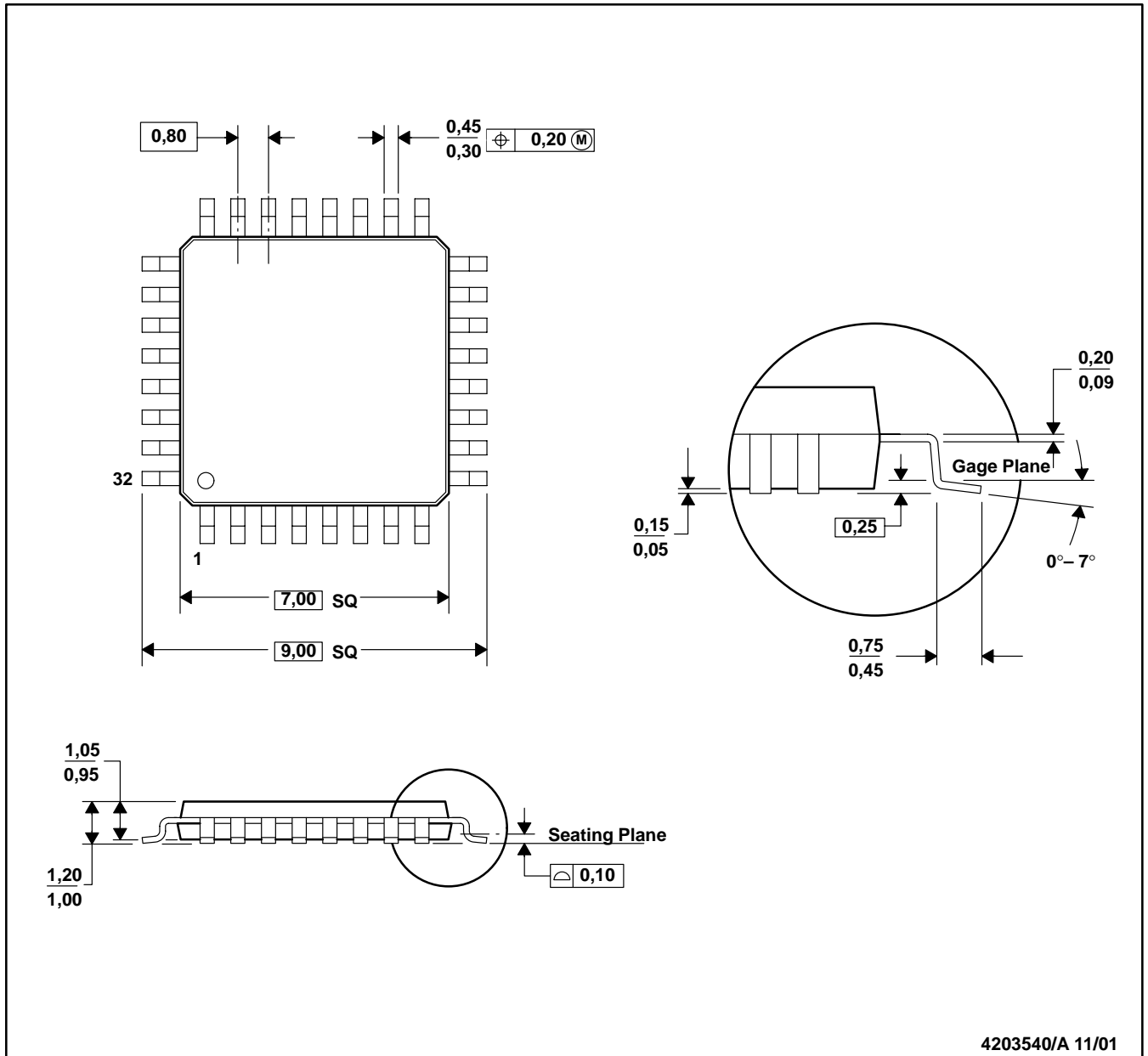

- NOTES: A. All linear dimensions are in millimeters.  
 B. This drawing is subject to change without notice.  
 C. Falls within JEDEC MS-026

## IMPORTANT NOTICE AND DISCLAIMER

TI PROVIDES TECHNICAL AND RELIABILITY DATA (INCLUDING DATASHEETS), DESIGN RESOURCES (INCLUDING REFERENCE DESIGNS), APPLICATION OR OTHER DESIGN ADVICE, WEB TOOLS, SAFETY INFORMATION, AND OTHER RESOURCES "AS IS" AND WITH ALL FAULTS, AND DISCLAIMS ALL WARRANTIES, EXPRESS AND IMPLIED, INCLUDING WITHOUT LIMITATION ANY IMPLIED WARRANTIES OF MERCHANTABILITY, FITNESS FOR A PARTICULAR PURPOSE OR NON-INFRINGEMENT OF THIRD PARTY INTELLECTUAL PROPERTY RIGHTS.

These resources are intended for skilled developers designing with TI products. You are solely responsible for (1) selecting the appropriate TI products for your application, (2) designing, validating and testing your application, and (3) ensuring your application meets applicable standards, and any other safety, security, or other requirements. These resources are subject to change without notice. TI grants you permission to use these resources only for development of an application that uses the TI products described in the resource. Other reproduction and display of these resources is prohibited. No license is granted to any other TI intellectual property right or to any third party intellectual property right. TI disclaims responsibility for, and you will fully indemnify TI and its representatives against, any claims, damages, costs, losses, and liabilities arising out of your use of these resources.

TI's products are provided subject to TI's Terms of Sale ([www.ti.com/legal/termsofsale.html](http://www.ti.com/legal/termsofsale.html)) or other applicable terms available either on [ti.com](http://ti.com) or provided in conjunction with such TI products. TI's provision of these resources does not expand or otherwise alter TI's applicable warranties or warranty disclaimers for TI products.

Mailing Address: Texas Instruments, Post Office Box 655303, Dallas, Texas 75265  
Copyright © 2018, Texas Instruments Incorporated

## Looking for pricing, stock, or lifecycle information?

Click below to explore more details on WIN SOURCE:

 [View PCM2704DBR](#) on WIN SOURCE

 [Texas Instruments](#) Information

## Optimize Your Supply Chain with WIN SOURCE Solutions

-  Global Sourcing Solution
-  Obsolete Management
-  Cost Control Management
-  Shortage Management
-  Alternative Solution
-  Excess Inventory Management