



## PCM1789 24-Bit, 192-kHz Sampling, Enhanced Multi-Level $\Delta\Sigma$ , Stereo, Audio Digital-to-Analog Converter

### 1 Features

- Enhanced Multi-Level Delta-Sigma DAC:
  - High Performance: Differential,  $f_S = 48$  kHz
  - THD+N:  $-94$  dB
  - SNR: 113 dB
  - Dynamic Range: 113 dB
  - Sampling Rate: 8 kHz to 192 kHz
  - System Clock: 128  $f_S$ , 192  $f_S$ , 256  $f_S$ , 384  $f_S$ , 512  $f_S$ , 768  $f_S$ , 1152  $f_S$
  - Differential Voltage Output: 8  $V_{PP}$
  - Analog Low-Pass Filter Included
  - 4x/8x Oversampling Digital Filter:
    - Passband Ripple:  $\pm 0.0018$  dB
    - Stop Band Attenuation:  $-75$  dB
  - Zero Flags (16-, 20-, 24-Bits)
- Flexible Audio Interface:
  - I/F Format: I<sup>2</sup>S, Left-/Right-Justified, DSP
  - Data Length: 16, 20, 24, 32 Bits
- Flexible Mode Control:
  - 3-Wire SPI, 2-Wire I<sup>2</sup>C-Compatible Serial Control Interface, or Hardware Control
  - Connect Up To 4 Devices on One SPI Bus
- Multi Functions via SPI or I<sup>2</sup>C I/F:
  - Audio I/F Format Select: I<sup>2</sup>S, Left-Justified, Right-Justified, DSP
  - Digital Attenuation and Soft Mute
  - Digital De-Emphasis: 32kHz, 44.1kHz, 48kHz
  - Data Polarity Control
  - Power-Save Mode
- Multi Functions via Hardware Control:
  - Audio I/F Format Select: I<sup>2</sup>S, Left-Justified
  - Digital De-Emphasis Filter: 44.1kHz
- Analog Mute by Clock Halt Detection
- External Reset Pin
- Power Supplies:
  - 5 V for Analog and 3.3 V for Digital
- Package: TSSOP-24
- Operating Temperature Range:  $-40^{\circ}\text{C}$  to  $85^{\circ}\text{C}$

### 2 Applications

- Blu-ray Disc™ Players
- DVD Players
- AV Receivers
- Home Theaters
- Car Audio External Amplifiers
- Car Audio AVN Applications

### 3 Description

The PCM1789 is a high-performance, single-chip, 24-bit, stereo, audio digital-to-analog converter (DAC) with differential outputs. The two-channel, 24-bit DAC employs an enhanced multi-level, delta-sigma ( $\Delta\Sigma$ ) modulator, and supports 8 kHz to 192 kHz sampling rates and a 16-, 20-, 24-, 32-bit width digital audio input word on the audio interface. The audio interface of PCM1789 supports a 24-bit, DSP format in addition to I<sup>2</sup>S, left-justified, and right-justified formats.

The PCM1789 can be controlled through a three-wire, SPI-compatible or two-wire, I<sup>2</sup>C-compatible serial interface in software, which provides access to all functions including digital attenuation, soft mute, de-emphasis, and so forth. Also, hardware control mode provides two user-programmable functions through two control pins. The PCM1789 is available in a 24-pin TSSOP package.

#### Device Information<sup>(1)</sup>

PART NUMBER	PACKAGE	BODY SIZE (NOM)
PCM1789	TSSOP (24)	4.40 mm x 7.80 mm

(1) For all available packages, see the orderable addendum at the end of the data sheet.

#### PCM1789 Typical Application

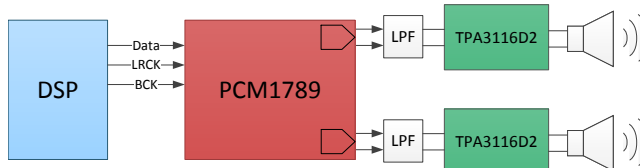

## Table of Contents

<b>1 Features</b> ..... 1 <b>2 Applications</b> ..... 1 <b>3 Description</b> ..... 1 <b>4 Revision History</b> ..... 2 <b>5 Pin Configuration and Functions</b> ..... 3 <b>6 Specifications</b> ..... 4 6.1 Absolute Maximum Ratings ..... 4 6.2 ESD Ratings ..... 4 6.3 Recommended Operating Conditions ..... 4 6.4 Thermal Information ..... 5 6.5 Electrical Characteristics: Digital Input/Output ..... 5 6.6 Electrical Characteristics: DAC ..... 6 6.7 Electrical Characteristics: Power-Supply Requirements ..... 7 6.8 System Clock Timing Requirements ..... 7 6.9 Audio Interface Timing Requirements ..... 7 6.10 Three-Wire Timing Requirements ..... 8 6.11 SCL and SDA Timing Requirements ..... 8 6.12 Typical Characteristics ..... 9 <b>7 Detailed Description</b> ..... 13 7.1 Overview ..... 13	7.2 Functional Block Diagram ..... 13 7.3 Feature Description ..... 13 7.4 Device Functional Modes ..... 18 7.5 Register Maps ..... 23 <b>8 Application and Implementation</b> ..... 29 8.1 Application Information ..... 29 8.2 Typical Application ..... 31 8.3 Application Curve ..... 32 <b>9 Power Supply Recommendations</b> ..... 32 <b>10 Layout</b> ..... 33 10.1 Layout Guidelines ..... 33 10.2 Layout Example ..... 33 <b>11 Device and Documentation Support</b> ..... 34 11.1 Documentation Support ..... 34 11.2 Community Resources ..... 34 11.3 Trademarks ..... 34 11.4 Electrostatic Discharge Caution ..... 34 11.5 Glossary ..... 34 <b>12 Mechanical, Packaging, and Orderable Information</b> ..... 34
---	--

## 4 Revision History

NOTE: Page numbers for previous revisions may differ from page numbers in the current version.

Changes from Revision A (January 2009) to Revision B	Page
<ul style="list-style-type: none"> <li>• Added <i>ESD Ratings</i> table, <i>Feature Description</i> section, <i>Device Functional Modes</i> section, <i>Application and Implementation</i> section, <i>Power Supply Recommendations</i> section, <i>Layout</i> section, <i>Device and Documentation Support</i> section, and <i>Mechanical, Packaging, and Orderable Information</i> section. ....</li> </ul>	1

Changes from Original (October 2008) to Revision A	Page
<ul style="list-style-type: none"> <li>• Changed <a href="#">Figure 39</a> .....</li> </ul>	31

## 5 Pin Configuration and Functions

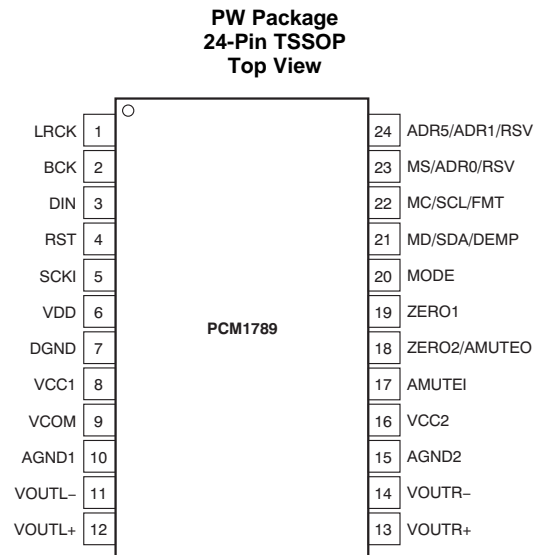

### Pin Functions

PIN		I/O	PULL-DOWN	5-V TOLERANT	DESCRIPTION
NAME	NO.				
LRCK	1	I	Yes	No	Audio data word clock input
BCK	2	I	Yes	No	Audio data bit clock input
DIN	3	I	No	No	Audio data input
RST	4	I	Yes	Yes	Reset and power-down control input with active low
SCKI	5	I	No	Yes	System clock input
VDD	6	—	—	—	Digital power supply, +3.3 V
DGND	7	—	—	—	Digital ground
VCC1	8	—	—	—	Analog power supply 1, +5 V
VCOM	9	—	—	—	Voltage common decoupling
AGND1	10	—	—	—	Analog ground 1
VOU <sub>TL-</sub>	11	O	No	No	Negative analog output from DAC left channel
VOU <sub>TL+</sub>	12	O	No	No	Positive analog output from DAC left channel
VOU <sub>TR+</sub>	13	O	No	No	Positive analog output from DAC right channel
VOU <sub>TR-</sub>	14	O	No	No	Negative analog output from DAC right channel
AGND2	15	—	—	—	Analog ground 2
VCC2	16	—	—	—	Analog power supply 2, +5 V
AMUTEI	17	I	No	Yes	Analog mute control input with active low
ZERO2/AMUTEO	18	O	No	No	Zero detect flag output 2/Analog mute control output <sup>(1)</sup> with active low
ZERO1	19	O	No	No	Zero detect flag output 1
MODE	20	I	No	No	Control port mode selection. Tied to VDD: SPI, ADR6 = 1, pull-up: SPI, ADR6 = 0, pull-down: H/W auto mode, tied to DGND: I <sup>2</sup> C
MD/SDA/DEMP	21	I/O	No	Yes	Input data for SPI, data for I <sup>2</sup> C <sup>(1)</sup> , de-emphasis control for hardware control mode
MC/SCL/FMT	22	I	No	Yes	Clock for SPI, clock for I <sup>2</sup> C, format select for hardware control mode
MS/ADR0/RSV	23	I	Yes	Yes	Chip Select for SPI, address select 0 for I <sup>2</sup> C, reserve (set low) for hardware control mode
ADR5/ADR1/RSV	24	I	No	Yes	Address select 5 for SPI, address select 1 for I <sup>2</sup> C, reserve (set low) for hardware control mode

(1) Open-drain configuration in out mode.

## 6 Specifications

### 6.1 Absolute Maximum Ratings

over operating free-air temperature range (unless otherwise noted)<sup>(1)</sup>

		MIN	MAX	UNIT
Supply voltage	VCC1, VCC2	-0.3	6.5	V
	VDD	-0.3	4.0	
Ground voltage differences	AGND1, AGND2, DGND		±0.1	V
Supply voltage differences	VCC1, VCC2		0.1	V
Digital input voltage	RST, ADR5, MS, MC, MD, SCKI, AMUTEI	-0.3	6.5	V
	BCK, LRCK, DIN, MODE, ZERO1, ZERO2	-0.3	(VDD + 0.3) < +4.0	
Analog input voltage	VCOM, VOUL±, VOUL±	-0.3	(VCC + 0.3) < +6.5	V
Input current (all pins except supplies)			±10	mA
Ambient temperature under bias		-40	125	°C
Junction temperature			150	°C
Package temperature (IR reflow, peak)			260	°C
Storage temperature, T <sub>stg</sub>		-55	150	°C

- (1) Stresses beyond those listed under *Absolute Maximum Ratings* may cause permanent damage to the device. These are stress ratings only, which do not imply functional operation of the device at these or any other conditions beyond those indicated under *Recommended Operating Conditions*. Exposure to absolute-maximum-rated conditions for extended periods may affect device reliability.

### 6.2 ESD Ratings

		VALUE	UNIT
V <sub>(ESD)</sub> Electrostatic discharge	Human-body model (HBM), per ANSI/ESDA/JEDEC JS-001 <sup>(1)</sup>	±1000	V
	Charged-device model (CDM), per JEDEC specification JESD22-C101 <sup>(2)</sup>	±250	

- (1) JEDEC document JEP155 states that 500-V HBM allows safe manufacturing with a standard ESD control process.  
 (2) JEDEC document JEP157 states that 250-V CDM allows safe manufacturing with a standard ESD control process.

### 6.3 Recommended Operating Conditions

over operating free-air temperature range (unless otherwise noted)

		MIN	NOM	MAX	UNIT
Analog supply voltage, VCC		4.5	5.0	5.5	V
Digital supply voltage, VDD		3.0	3.3	3.6	V
Digital Interface		LVTTTL-compatible			
Digital input clock frequency	Sampling frequency, LRCK	8		192	kHz
	System clock frequency, SCKI	2.048		36.864	MHz
Analog output voltage	Differential		8		V <sub>PP</sub>
Analog output load resistance	To ac-coupled GND	5			kΩ
	To dc-coupled GND	15			
Analog output load capacitance				50	pF
Digital output load capacitance				20	pF
Operating free-air temperature	PCM1789 consumer grade	-40	25	85	°C

## 6.4 Thermal Information

THERMAL METRIC <sup>(1)</sup>		PCM1789	UNIT
		PW (TSSOP)	
		24 PINS	
R <sub>θJA</sub>	Junction-to-ambient thermal resistance	87.8	°C/W
R <sub>θJC(top)</sub>	Junction-to-case (top) thermal resistance	19.3	°C/W
R <sub>θJB</sub>	Junction-to-board thermal resistance	42.6	°C/W
ψ <sub>JT</sub>	Junction-to-top characterization parameter	0.5	°C/W
ψ <sub>JB</sub>	Junction-to-board characterization parameter	42.1	°C/W
R <sub>θJC(bot)</sub>	Junction-to-case (bottom) thermal resistance	n/a	°C/W

(1) For more information about traditional and new thermal metrics, see the *Semiconductor and IC Package Thermal Metrics* application report, [SPRA953](#).

## 6.5 Electrical Characteristics: Digital Input/Output

All specifications at T<sub>A</sub> = +25°C, VCC1 = VCC2 = 5 V, VDD = 3.3 V, f<sub>S</sub> = 48 kHz, SCKI = 512 f<sub>S</sub>, 24-bit data, and Sampling mode = Auto, unless otherwise noted.

PARAMETER	TEST CONDITIONS	MIN	TYP	MAX	UNIT
<b>DATA FORMAT</b>					
f <sub>S</sub>	Sampling frequency	8	48	192	kHz
	System clock frequency	128 f <sub>S</sub> , 192 f <sub>S</sub> , 256 f <sub>S</sub> , 384 f <sub>S</sub> , 512 f <sub>S</sub> , 768 f <sub>S</sub> , 1152 f <sub>S</sub>	2.048	36.864	MHz
<b>INPUT LOGIC</b>					
	LOGIC FAMILY				
V <sub>IH</sub>	Input logic level, high (BCK, LRCK, and DIN)	2.0		VDD	VDC
V <sub>IL</sub>	Input logic level, low (BCK, LRCK, and DIN)			0.8	VDC
V <sub>IH</sub>	Input logic current, high (SCKI, ADR5/ADR1/RSV, MC/SCL/FMT, MD/SDA?DEMP, and AMUTEI)	2.0		5.5	VDC
V <sub>IL</sub>	Input logic current, low (SCKI, ADR5/ADR1/RSV, MC/SCL/FMT, MD/SDA/DEMP, and AMUTEI)			0.8	VDC
I <sub>IH</sub>	Input logic current, high (DIN, SCKI, ADR5/ADR1/RSV, MC/SCL/FMT, MD/SDA/DEMP, and AMUTEI)	V <sub>IN</sub> = VDD		±10	μA
I <sub>IL</sub>	Input logic current, low (DIN, SCKI, ADR5/ADR1/RSV, MC/SCL/FMT, MD/SDA/DEMP, and AMUTEI)	V <sub>IN</sub> = 0 V		±10	μA
I <sub>IH</sub>	Input logic current, high (BCK, LRCK, RST, MS/ADR0/RSV)	V <sub>IN</sub> = VDD	+65	+100	μA
	Input logic current, low (BCK, LRCK, RST, MS/ADR0/RSV)	V <sub>IN</sub> = 0 V		±10	μA
<b>OUTPUT LOGIC</b>					
V <sub>OH</sub>	Output logic level, high (ZERO1 and ZERO2)	I <sub>OUT</sub> = -4 mA	2.4		VDC
V <sub>OL</sub>	Output logic level, high (ZERO1 and ZERO2)	I <sub>OUT</sub> = +4 mA		0.4	VDC
<b>REFERENCE OUTPUT</b>					
	VCOM output voltage		0.5 × VCC1		V
	VCOM output impedance		7.5		kΩ
	Allowable VCOM output source/sink current			1	μA

## 6.6 Electrical Characteristics: DAC

All specifications at  $T_A = +25^\circ\text{C}$ ,  $V_{CC1} = V_{CC2} = 5\text{ V}$ ,  $V_{DD} = 3.3\text{ V}$ ,  $f_S = 48\text{ kHz}$ ,  $SCKI = 512 f_S$ , 24-bit data, and Sampling mode = Auto, unless otherwise noted.

PARAMETER		TEST CONDITIONS	MIN	TYP	MAX	UNIT
<b>RESOLUTION</b>			16	24		Bits
<b>DC ACCURACY</b>						
Gain mismatch channel-to-channel			x	$\pm 2.0$	$\pm 6.0$	% of FSR
Gain error				$\pm 2.0$	$\pm 6.0$	% of FSR
Bipolar zero error				$\pm 1.0$		% of FSR
<b>DYNAMIC PERFORMANCE<sup>(1)</sup> <sup>(2)</sup></b>						
THD+N	Total harmonic distortion + noise	$V_{OUT} = 0\text{ dB}$	$f_S = 48\text{ kHz}$	-94	-88	dB
			$f_S = 96\text{ kHz}$	-94		dB
			$f_S = 192\text{ kHz}$	-94		dB
Dynamic range		$f_S = 48\text{ kHz}$ , EIAJ, A-weighted	106	113		dB
		$f_S = 96\text{ kHz}$ , EIAJ, A-weighted		113		dB
		$f_S = 192\text{ kHz}$ , EIAJ, A-weighted		113		dB
SNR	Signal-to-noise ratio	$f_S = 48\text{ kHz}$ , EIAJ, A-weighted	106	113		dB
		$f_S = 96\text{ kHz}$ , EIAJ, A-weighted		113		dB
		$f_S = 192\text{ kHz}$ , EIAJ, A-weighted		113		dB
Channel separation		$f_S = 48\text{ kHz}$	103	109		dB
		$f_S = 96\text{ kHz}$		109		dB
		$f_S = 192\text{ kHz}$		108		dB
<b>ANALOG OUTPUT</b>						
Output voltage	Differential			$1.6 \times V_{CC1}$		$V_{PP}$
Center voltage				$0.5 \times V_{CC1}$		V
Load impedance	To ac-coupled GND <sup>(3)</sup>		5			k $\Omega$
	To dc-coupled GND <sup>(3)</sup>		15			k $\Omega$
LPF frequency response	f = 20 kHz			-0.04		dB
	f = 44 kHz			-0.18		dB
<b>DIGITAL FILTER PERFORMANCE WITH SHARP ROLL-OFF</b>						
Passband (single, dual)	Except $SCKI = 128 f_S$ and $192 f_S$			$0.454 \times f_S$		Hz
	$SCKI = 128 f_S$ and $192 f_S$			$0.432 \times f_S$		Hz
Passband (quad)				$0.432 \times f_S$		Hz
Stop band (single, dual)	Except $SCKI = 128 f_S$ and $192 f_S$		$0.546 \times f_S$			Hz
	$SCKI = 128 f_S$ and $192 f_S$		$0.569 \times f_S$			Hz
Stop band (quad)			$0.569 \times f_S$			Hz
Passband ripple	$< 0.454 \times f_S, 0.432 \times f_S$				$\pm 0.0018$	dB
Stop band attenuation	$> 0.546 \times f_S, 0.569 \times f_S$		-75			dB
<b>DIGITAL FILTER PERFORMANCE WITH SLOW ROLL-OFF</b>						
Passband				$0.328 \times f_S$		Hz
Stop band			$0.673 \times f_S$			Hz
Passband ripple	$< 0.328 \times f_S$				$\pm 0.0013$	dB
Stop band attenuation	$> 0.673 \times f_S$		-75			dB
<b>DIGITAL FILTER PERFORMANCE</b>						
Group delay time (single, dual)	Except $SCKI = 128 f_S$ and $192 f_S$			$28/f_S$		sec
	$SCKI = 128 f_S$ and $192 f_S$			$19/f_S$		sec
Group delay time (quad)				$19/f_S$		sec
De-emphasis error				$\pm 0.1$		dB

(1) In differential mode at  $V_{OUTx\pm}$  pin,  $f_{OUT} = 1\text{ kHz}$ , using Audio Precision System II, Average mode with 20-kHz LPF and 400-Hz HPF.

(2)  $f_S = 48\text{ kHz}$ :  $SCKI = 512 f_S$  (single),  $f_S = 96\text{ kHz}$ :  $SCKI = 256 f_S$  (dual),  $f_S = 192\text{ kHz}$ :  $SCKI = 128 f_S$  (quad).

(3) Allowable minimum input resistance of differential-to-single-ended converter with D-to-S gain = G is calculated as  $(1 + 2G)/(1 + G) \times 5\text{ k}\Omega$  for ac-coupled, and  $(1 + 0.9G)/(1 + G) \times 15\text{ k}\Omega$  for dc-coupled connection; refer to [Figure 37](#) and [Figure 38](#).

## 6.7 Electrical Characteristics: Power-Supply Requirements

All specifications at  $T_A = +25^\circ\text{C}$ ,  $V_{CC1} = V_{CC2} = 5\text{ V}$ ,  $V_{DD} = 3.3\text{ V}$ ,  $f_S = 48\text{ kHz}$ ,  $SCKI = 512 f_S$ , 24-bit data, and Sampling mode = Auto, unless otherwise noted.

PARAMETER		TEST CONDITIONS	MIN	TYP	MAX	UNIT
<b>POWER-SUPPLY REQUIREMENTS</b>						
VCC1/2	Voltage range		4.5	5.0	5.5	VDC
VDD			3.0	3.3	3.6	VDC
I <sub>CC</sub>	Supply current	$f_S = 48\text{ kHz}$		19	28	mA
		$f_S = 192\text{ kHz}$		19		mA
		Full power-down <sup>(1)</sup>		170		μA
I <sub>DD</sub>		$f_S = 48\text{ kHz}$		18	30	mA
		$f_S = 192\text{ kHz}$		22		mA
		Full power-down <sup>(1)</sup>		60		μA
Power dissipation		$f_S = 48\text{ kHz}$		154	239	mW
		$f_S = 192\text{ kHz}$		168		mW
		Full power-down <sup>(1)</sup>		1.05		mW
<b>TEMPERATURE RANGE</b>						
Operating temperature		PCM1789 consumer grade	-40		+85	°C
θ <sub>JA</sub>	Thermal resistance	TSSOP-24		115		°C/W

(1) SCKI, BCK, and LRCK stopped.

## 6.8 System Clock Timing Requirements

(see [Figure 19](#))

		MIN	NOM	MAX	UNIT
t <sub>SCY</sub>	System clock cycle time	27			ns
t <sub>SCH</sub>	System clock width high	10			ns
t <sub>SCL</sub>	System clock width low	10			ns
—	System clock duty cycle	40%	60%		

## 6.9 Audio Interface Timing Requirements

(see [Figure 35](#))

		MIN	NOM	MAX	UNIT
t <sub>BCY</sub>	BCK cycle time	75			ns
t <sub>BCH</sub>	BCK pulse width high	35			ns
t <sub>BCL</sub>	BCK pulse width low	35			ns
t <sub>LRW</sub>	LRCK pulse width high (LJ, RJ and I <sup>2</sup> S formats)	1/(2 × f <sub>S</sub> )		1/(2 × f <sub>S</sub> )	s
	LRCK pulse width high (DSP format)	t <sub>BCY</sub>		t <sub>BCY</sub>	s
t <sub>LRS</sub>	LRCK setup time to BCK rising edge	10			ns
t <sub>LRH</sub>	LRCK hold time to BCK rising edge	10			ns
t <sub>DIS</sub>	DIN setup time to BCK rising edge	10			ns
t <sub>DIH</sub>	DIN hold time to BCK rising edge	10			ns

## 6.10 Three-Wire Timing Requirements

 (See [Figure 24](#))

		MIN	NOM	MAX	UNIT
$t_{MCY}$	MC pulse cycle time	100			ns
$t_{MCL}$	MC low-level time	40			ns
$t_{MCH}$	MC high-level time	40			ns
$t_{HCH}$	MS high-level time	$t_{MCY}$			ns
$t_{MSS}$	MS falling edge to MC rising edge	30			ns
$t_{MHS}$	MS rising edge from MC rising edge for LSB	15			ns
$t_{MDH}$	MS hold time	15			ns
$t_{MDS}$	MD setup time	15			ns

## 6.11 SCL and SDA Timing Requirements

 (See [Figure 1](#))

	STANDARD MODE		FAST MODE		UNIT		
	MIN	MAX	MIN	MAX			
$f_{SCL}$	SCL clock frequency		100		400	kHz	
$t_{BUF}$	Bus free time between STOP and START condition		4.7		1.3	$\mu$ s	
$t_{LOW}$	Low period of the SCL clock		4.7		1.3	$\mu$ s	
$t_{HI}$	High period of the SCL clock		4.0		0.6	$\mu$ s	
$t_{S-SU}$	Setup time for START/Repeated START condition		4.7		0.6	$\mu$ s	
$t_{S-HD}$	Hold time for START/Repeated START condition		4.0		0.6	$\mu$ s	
$t_{D-SU}$	Data setup time		250		100	ns	
$t_{D-HD}$	Data hold time		0	3450	0	900	ns
$t_{SCL-R}$	Rise time of SCL signal		1000		$20 + 0.1 C_B$	300	ns
$t_{SCL-F}$	Fall time of SCL signal		1000		$20 + 0.1 C_B$	300	ns
$t_{SDA-R}$	Rise time of SDA signal		1000		$20 + 0.1 C_B$	300	ns
$t_{SDA-F}$	Fall time of SDA signal		1000		$20 + 0.1 C_B$	300	ns
$t_{P-SU}$	Setup time for STOP condition		4.0		0.6	$\mu$ s	
$t_{GW}$	Allowable glitch width		N/A		50	ns	
$C_B$	Capacitive load for SDA and SCL line		400		100	pF	
$V_{NH}$	Noise margin at high level for each connected device (including hysteresis)		$0.2 \times V_{DD}$		$0.2 \times V_{DD}$	V	
$V_{NL}$	Noise margin at low level for each connected device (including hysteresis)		$0.1 \times V_{DD}$		$0.1 \times V_{DD}$	V	
$V_{HYS}$	Hysteresis of Schmitt trigger input		N/A		$0.05 \times V_{DD}$	V	

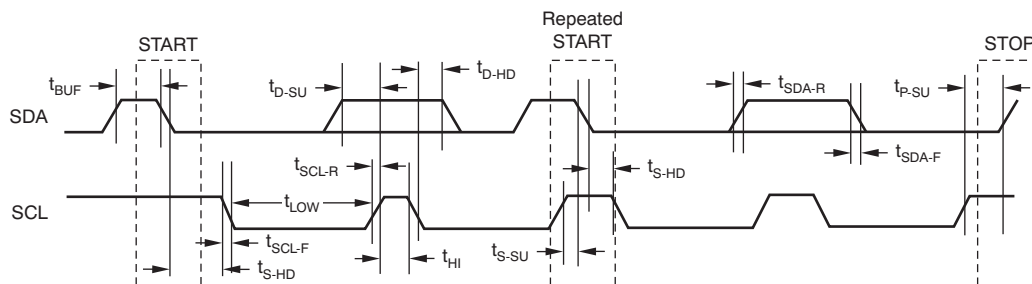
**Figure 1. SCL and SDA Control Interface Timing**

## 6.12 Typical Characteristics

### 6.12.1 Digital Filter

All specifications at  $T_A = 25^\circ\text{C}$ ,  $V_{CC1} = V_{CC2} = 5\text{ V}$ ,  $V_{DD} = 3.3\text{ V}$ ,  $f_S = 48\text{ kHz}$ ,  $SCKI = 512 f_S$ , 24-bit data, and Sampling mode = Auto, unless otherwise noted.

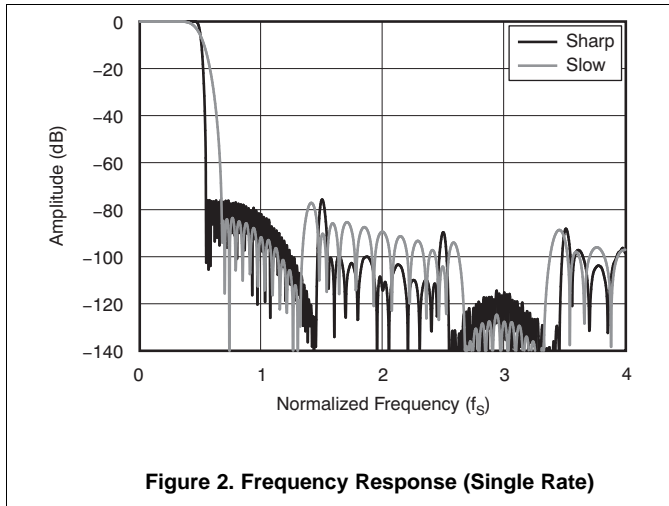

**Figure 2. Frequency Response (Single Rate)**

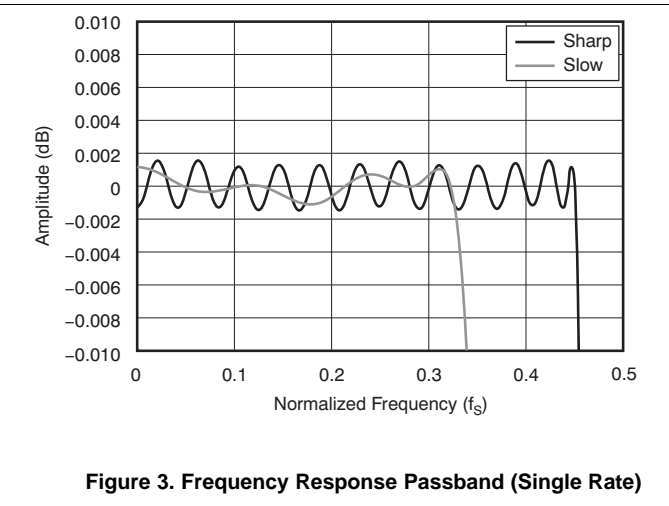

**Figure 3. Frequency Response Passband (Single Rate)**

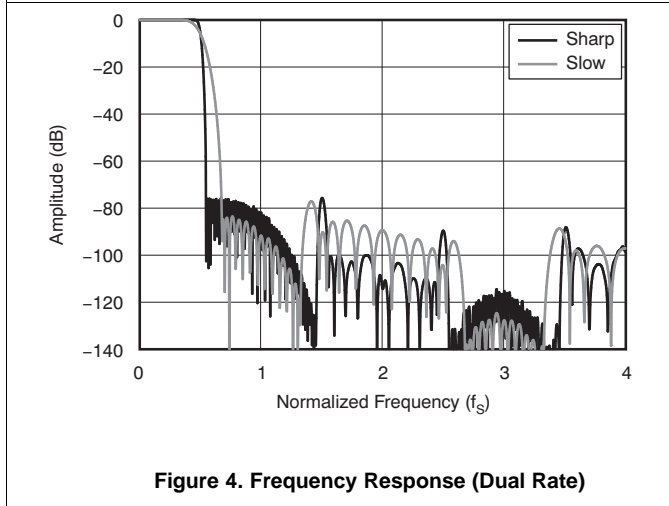

**Figure 4. Frequency Response (Dual Rate)**

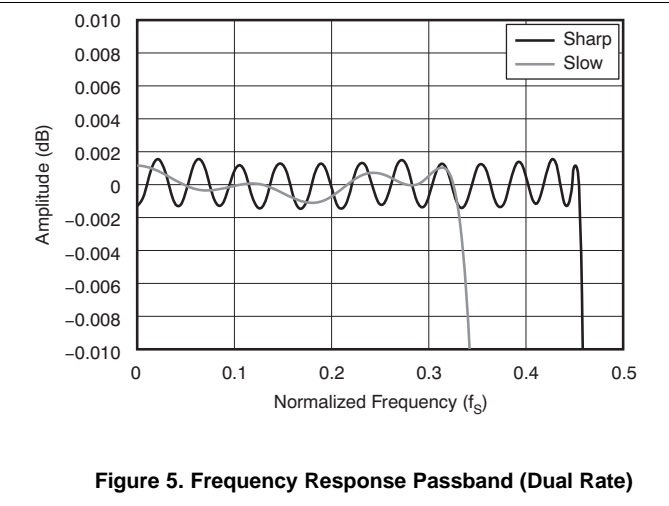

**Figure 5. Frequency Response Passband (Dual Rate)**

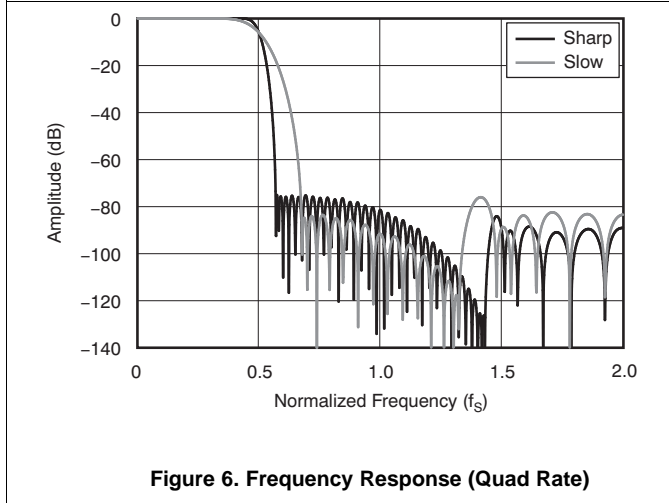

**Figure 6. Frequency Response (Quad Rate)**

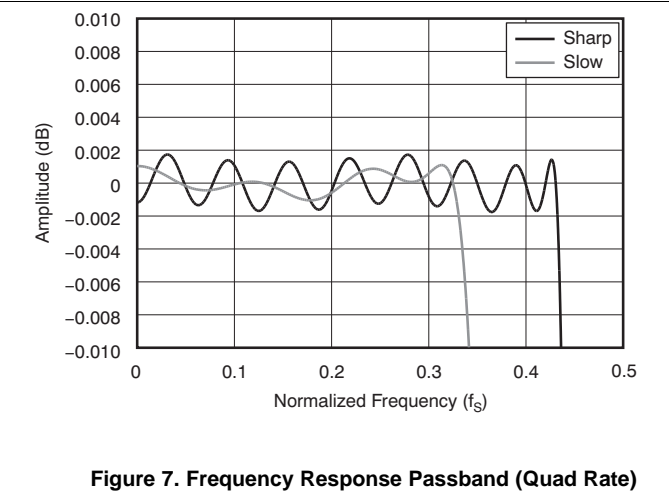

**Figure 7. Frequency Response Passband (Quad Rate)**

### 6.12.2 Digital De-Emphasis Filter

All specifications at  $T_A = +25^\circ\text{C}$ ,  $V_{CC1} = V_{CC2} = 5\text{ V}$ ,  $V_{DD} = 3.3\text{ V}$ ,  $f_S = 48\text{ kHz}$ ,  $SCKI = 512 f_S$ , 24-bit data, and Sampling mode = Auto, unless otherwise noted.

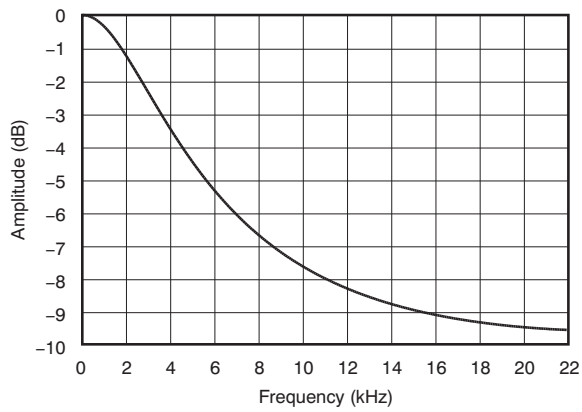

$f_S = 48\text{ kHz}$

Figure 8. De-emphasis Characteristic

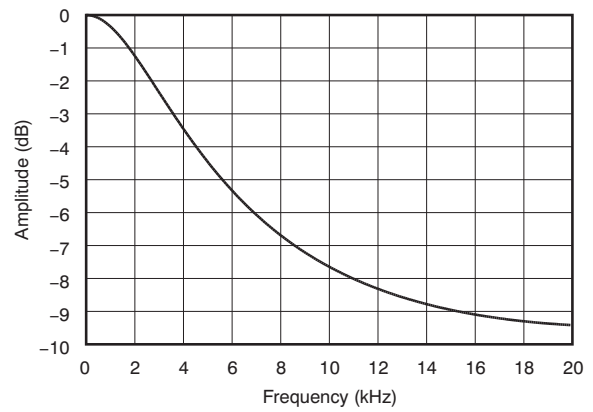

$f_S = 44.1\text{ kHz}$

Figure 9. De-emphasis Characteristic

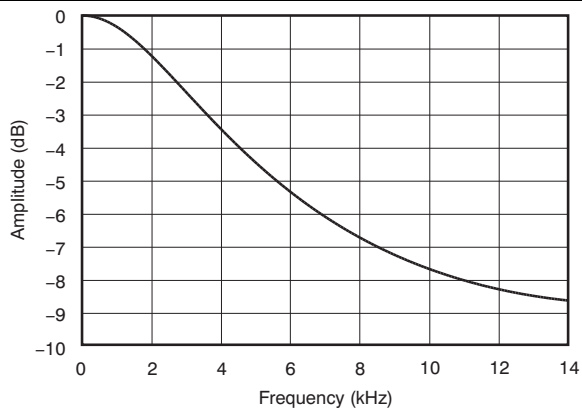

$f_S = 32\text{ kHz}$

Figure 10. De-emphasis Characteristic

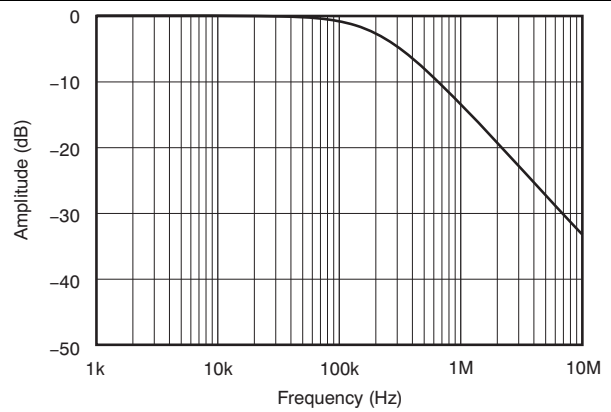

Figure 11. Analog Filter Characteristic

### 6.12.3 Dynamic Performance

All specifications at  $T_A = +25^\circ\text{C}$ ,  $V_{CC1} = V_{CC2} = 5\text{ V}$ ,  $V_{DD} = 3.3\text{ V}$ ,  $f_s = 48\text{ kHz}$ ,  $SCKI = 512 f_s$ , 24-bit data, and Sampling mode = Auto, unless otherwise noted.

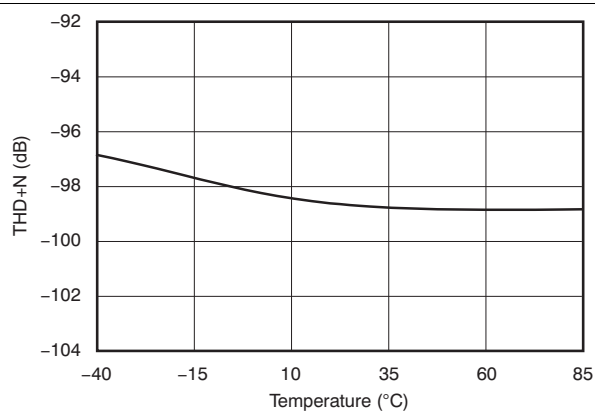

Figure 12. Total Harmonic Distortion + Noise vs Temperature

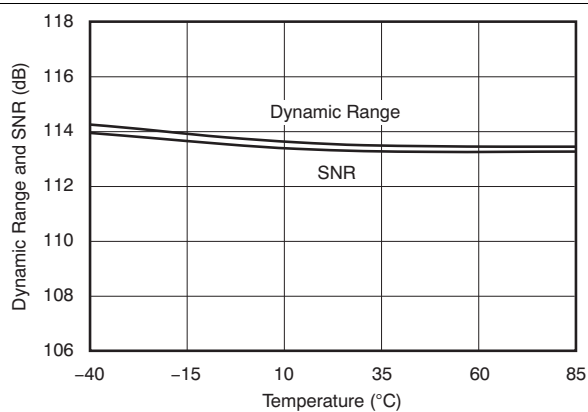

Figure 13. Dynamic Range and Signal-to-Noise Ratio vs Temperature

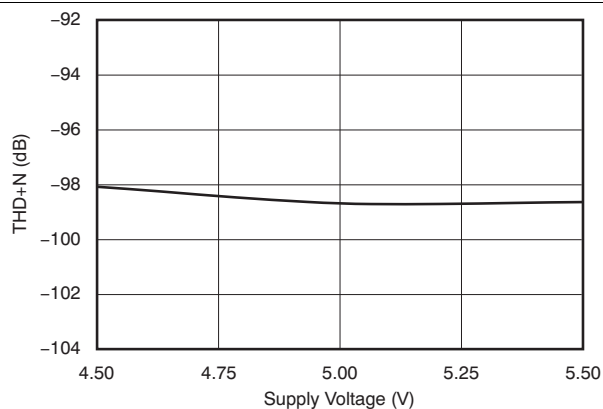

Figure 14. Total Harmonic Distortion + Noise vs Supply Voltage

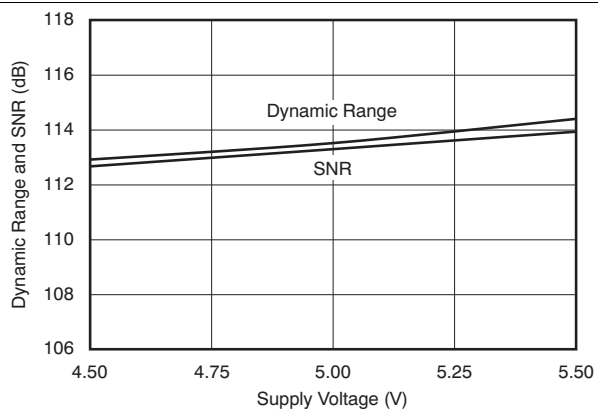
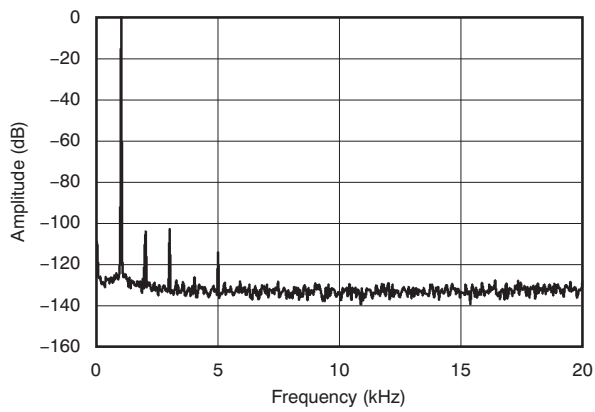

Figure 15. Dynamic Range and Signal-to-Noise Ratio vs Supply Voltage

### 6.12.4 Output Spectrum

All specifications at  $T_A = +25^\circ\text{C}$ ,  $V_{CC1} = V_{CC2} = 5\text{ V}$ ,  $V_{DD} = 3.3\text{ V}$ ,  $f_S = 48\text{ kHz}$ ,  $SCKI = 512 f_S$ , 24-bit data, and Sampling mode = Auto, unless otherwise noted.



0 dB, N = 32768

Figure 16. Output Spectrum

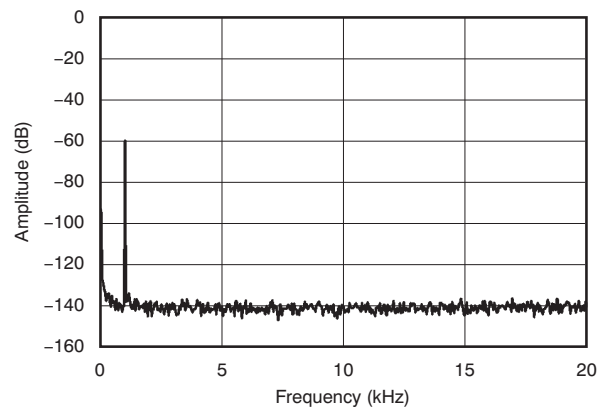

-60 dB, N = 32768

Figure 17. Output Spectrum

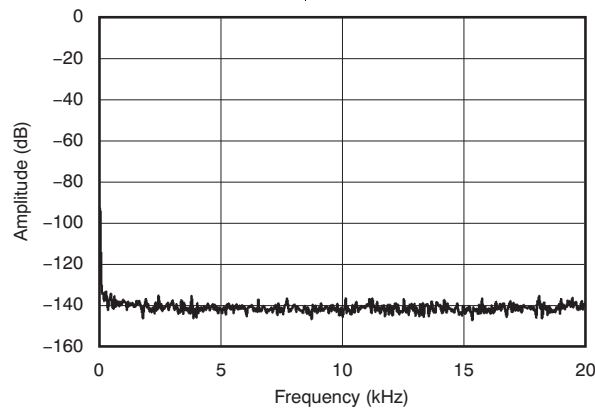

BPZ, N = 32768

Figure 18. Output Spectrum

## 7 Detailed Description

### 7.1 Overview

The PCM1789 is a high-performance stereo DAC targeted for consumer audio applications such as Blu-ray Disc players and DVD players, as well as home multi-channel audio applications (such as home theater and A/V receivers). The PCM1789 consists of a two-channel DAC. The DAC output type is fixed with a differential configuration. The PCM1789 supports 16-, 20-, 24-, 32-bit linear PCM input data in I<sup>2</sup>S and left-justified audio formats, and 24-bit linear PCM input data in right-justified and DSP formats with various sampling frequencies from 8 kHz to 192 kHz. The PCM1789 offers three modes for device control: two-wire I<sup>2</sup>C software, three-wire SPI software, and hardware.

- **Audio data interface formats:** I<sup>2</sup>S, LJ, RJ, DSP
- **Audio data word length:** 16, 20, 24, 32 Bits
- **Audio data format:** MSB first, twos complement

### 7.2 Functional Block Diagram

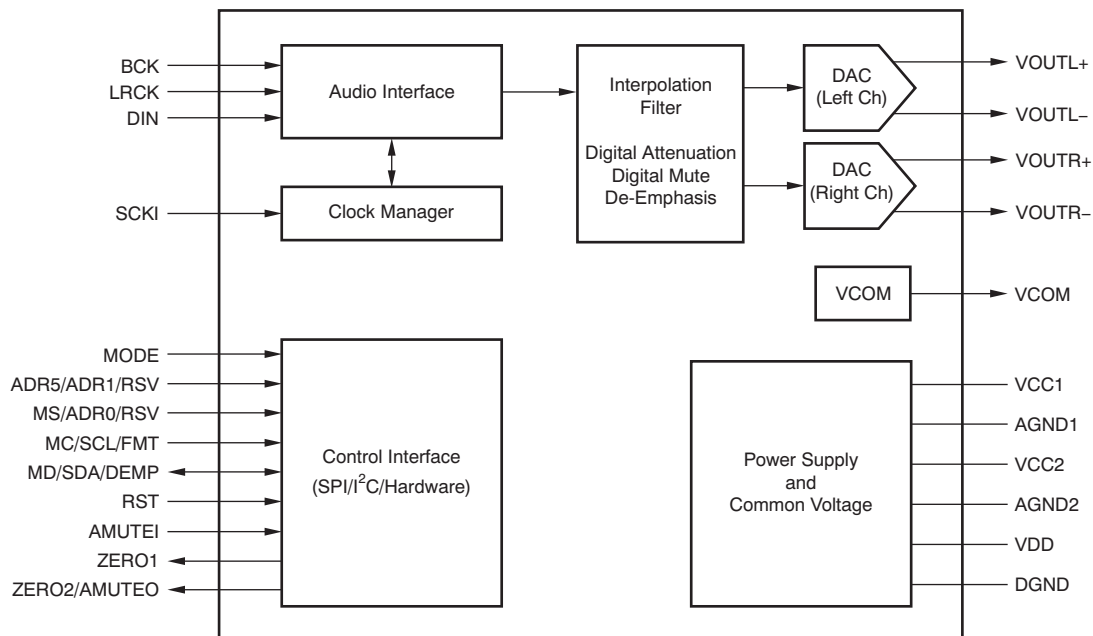

### 7.3 Feature Description

#### 7.3.1 Analog Outputs

The PCM1789 includes a two-channel DAC, with a pair of differential voltage outputs pins. The full-scale output voltage is  $(1.6 \times V_{CC1}) V_{PP}$  in differential output mode. A dc-coupled load is allowed in addition to an ac-coupled load, if the load resistance conforms to the specification. These balanced outputs are each capable of driving 0.8 VCC1 (4 V<sub>PP</sub>) typical into a 5-kΩ ac-coupled or 15-kΩ dc-coupled load with VCC1 = +5 V. The internal output amplifiers for VOUTL and VOUTR are biased to the dc common voltage, equal to 0.5 VCC1.

The output amplifiers include an RC continuous-time filter that helps to reduce the out-of-band noise energy present at the DAC outputs as a result of the noise shaping characteristics of the PCM1789 delta-sigma ( $\Delta\Sigma$ ) DACs. The frequency response of this filter is shown in the *Analog Filter Characteristic* (Figure 11) of the *Typical Characteristics*. By itself, this filter is not enough to attenuate the out-of-band noise to an acceptable level for most applications. An external low-pass filter is required to provide sufficient out-of-band noise rejection. Further discussion of DAC post-filter circuits is provided in the *Application Information* section.

## Feature Description (continued)

### 7.3.2 Voltage Reference VCOM

The PCM1789 includes a pin for the common-mode voltage output, VCOM. This pin should be connected to the analog ground via a decoupling capacitor. This pin can also be used to bias external high-impedance circuits, if they are required.

### 7.3.3 System Clock Input

The PCM1789 requires an external system clock input applied at the SCKI input for DAC operation. The system clock operates at an integer multiple of the sampling frequency, or  $f_S$ . The multiples supported in DAC operation include  $128 f_S$ ,  $192 f_S$ ,  $256 f_S$ ,  $384 f_S$ ,  $512 f_S$ ,  $768 f_S$ , and  $1152 f_S$ . Details for these system clock multiples are shown in [Table 1](#). The [System Clock Timing Requirements](#) table shows the SCKI timing requirements.

**Table 1. System Clock Frequencies for Common Audio Sampling Rates**

DEFAULT SAMPLING MODE	SAMPLING FREQUENCY, $f_S$ (kHz)	SYSTEM CLOCK FREQUENCY (MHz)						
		$128 f_S$	$192 f_S$	$256 f_S$	$384 f_S$	$512 f_S$	$768 f_S$	$1152 f_S$
Single rate	8	N/A	N/A	2.0480	3.0720	4.0960	6.1440	9.2160
	16	2.0480	3.0720	4.0960	6.1440	8.1920	12.2880	18.4320
	32	4.0960	6.1440	8.1920	12.2880	16.3840	24.5760	36.8640
	44.1	5.6448	8.4672	11.2896	16.9344	22.5792	33.8688	N/A
	48	6.1440	9.2160	12.2880	18.4320	24.5760	36.8640	N/A
Dual rate	88.2	11.2896	16.9344	22.5792	33.8688	N/A	N/A	N/A
	96	12.2880	18.4320	24.5760	36.8640	N/A	N/A	N/A
Quad rate	176.4	22.5792	33.8688	N/A	N/A	N/A	N/A	N/A
	192	24.5760	36.8640	N/A	N/A	N/A	N/A	N/A

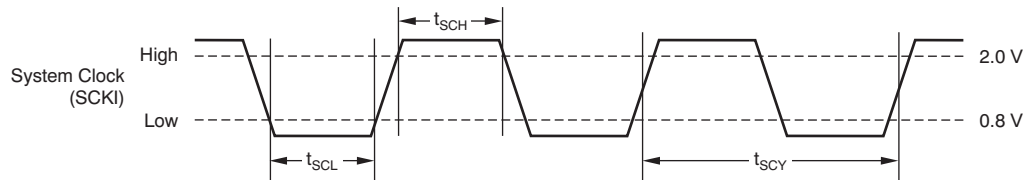

**Figure 19. System Clock Timing Diagram**

### 7.3.4 Reset Operation

The PCM1789 has both an internal power-on reset circuit and an external reset circuit. The sequences for both reset circuits are shown in [Figure 20](#) and [Figure 21](#). [Figure 20](#) illustrates the timing at the internal power-on reset. Initialization is triggered automatically at the point where VDD exceeds 2.2 V typical, and the internal reset is released after 3846 SCKI clock cycles from power-on, if RST is held high and SCKI is provided. VOUTx from the DAC is forced to the VCOM level initially (that is,  $0.5 \times VCC1$ ) and settles at a specified level according to the rising VCC. If synchronization among SCKI, BCK, and LRCK is maintained, VOUT provides an output that corresponds to DIN after 3846 SCKI clocks from power-on. If the synchronization is not held, the internal reset is not released, and both operating modes are maintained at reset and power-down states. After synchronization forms again, the DAC returns to normal operation with the previous sequences.

[Figure 21](#) illustrates a timing diagram at the external reset. RST accepts an externally-forced reset with RST low, and provides a device reset and power-down state that achieves the lowest power dissipation state available in the PCM1789. If RST goes from high to low under synchronization among SCKI, BCK, and LRCK, the internal reset is asserted, all registers and memory are reset, and finally, the PCM1789 enters into all power-down states. At the same time, VOUT is immediately forced into the AGND1 level. To begin normal operation again, toggle RST high; the same power-up sequence is performed as the power-on reset shown in [Figure 20](#).

The PCM1789 does not require particular power-on sequences for VCC and VDD; it allows VDD on and then VCC on, or VCC on and then VDD on. From the viewpoint of the *Absolute Maximum Ratings*, however, simultaneous power-on is recommended for avoiding unexpected responses on VOUTx. Figure 20 illustrates the response for VCC on with VDD on.

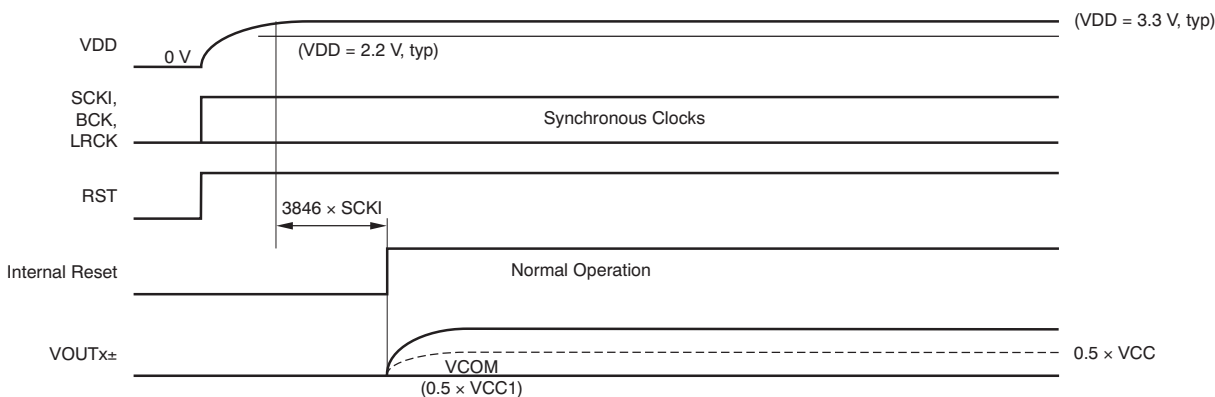

Figure 20. Power-On-Reset Timing Requirements

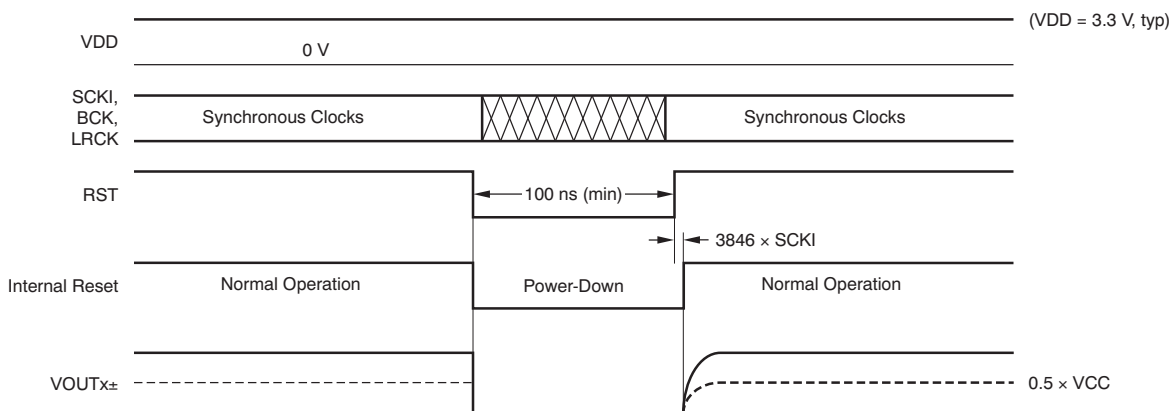

Figure 21. External Reset Timing Requirements

### 7.3.5 ZERO Flag

The PCM1789 has two ZERO flag pins (ZERO1 and ZERO2) that can be assigned to the combinations shown in Table 2. Zero flag combinations are selected through the AZRO bit in control register 22 (16h). If the input data of all the assigned channels remain at '0' for 1024 sampling periods (LRCK clock periods), the ZERO1/2 bits are set to a high level, logic '1' state. Furthermore, if the input data of any of the assigned channels read '1', the ZERO1/2 are set to a low level, logic '0' state, immediately. Zero data detection is supported for 16-/20-/24-bit data width, but is not supported for 32-bit data width.

The active polarity of the zero flag output can be inverted through the ZREV bit in control register 22 (16h). The reset default is active high for zero detection.

In parallel hardware control mode, ZERO1 and ZERO2 are fixed with combination A, shown in Table 2.

Table 2. Zero Flag Outputs Combination

ZERO FLAG COMBINATION	ZERO1	ZERO2
A	Left channel	Right channel
B	Left channel or right channel	Left channel and right channel

Note that the ZERO2 pin is multiplexed with AMUTE0 pin. Selection of ZERO2 or AMUTE0 can be changed through the MZSEL bit in control register 22 (16h). The default setting after reset is the selection of ZERO2.

### 7.3.6 AMUTE Control

The PCM1789 has an AMUTE control input, status output pins, and functionality. AMUTEI is the input control pin of the internal analog mute circuit. An AMUTEI low input causes the DAC output to cut-off from the digital input and forces it to the center level (0.5 VCC1). AMUTE0 is the status output pin of the internal analog mute circuit. AMUTE0 low indicates the analog mute control circuit is active because of a programmed condition (such as an SCKI halt, asynchronous detect, zero detect, or by the DAC disable command) that forces the DAC outputs to a center level. Because AMUTEI is not terminated internally and AMUTE0 is an open-drain output, pull-ups by the appropriate resistors are required for proper operation.

Note that the AMUTE0 pin is multiplexed with the ZERO2 pin. The desired pin is selected through the MZSEL bit in control register 22 (16h). The default setting is the selection of the ZERO2 pin.

Additionally, because the AMUTEI pin control and power-down control in register (OPEDA when high, PSMDA when low) do not function together, AMUTEI takes priority over power-down control. Therefore, power-down control is ignored during AMUTEI low, and AMUTEI low forces the DAC output to a center level (0.5 VCC1) even if power-down control is asserted.

### 7.3.7 Three-Wire (SPI) Serial Control

The PCM1789 includes an SPI-compatible serial port that operates asynchronously with the audio serial interface. The control interface consists of MD/SDA/DEMP, MC/SCL/FMT, and MS/ADR0/RSV. MD is the serial data input used to program the mode control registers. MC is the serial bit clock that shifts the data into the control port. MS is the select input used to enable the mode control port.

### 7.3.8 Control Data Word Format

All single write operations via the serial control port use 16-bit data words. Figure 22 shows the control data word format. The first bit (fixed at '0') is for write operation. After the first bit are seven other bits, labeled ADR[6:0], that set the register address for the write operation. ADR6 is determined by the status of the MODE pin. ADR5 is determined by the state of the ADR5/ADR1/RSV pin. A maximum of four PCM1789s can be connected on the same bus at any one time. Each PCM1789 responds when receiving its own register address. The eight least significant bits (LSBs), D[7:0] on MD, contain the data to be written to the register address specified by ADR[6:0].

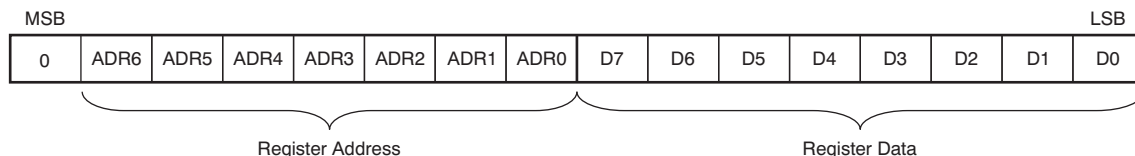
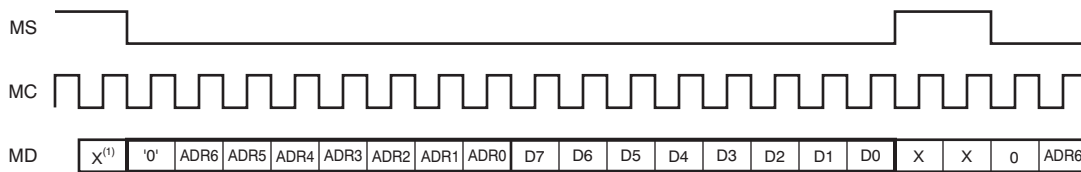

**Figure 22. Control Data Word Format for MD**

### 7.3.9 Register Write Operation

Figure 23 shows the functional timing diagram for single write operations on the serial control port. MS is held at a high state until a register is to be written to. To start the register write cycle, MS is set to a low state. 16 clocks are then provided on MC, corresponding to the 16 bits of the control data word on MD. After the 16th clock cycle has been completed, MS is set high to latch the data into the indexed mode control register.

In addition to single write operations, the PCM1789 also supports multiple write operations, which can be performed by sending the N-bytes (where  $N \leq 9$ ) of the 8-bit register data that follow after the first 16-bit register address and register data, while keeping the MC clocks and MS at a low state. Ending a multiple write operation can be accomplished by setting MS to a high state.



(1) X = don't care.

Figure 23. Register Write Operation

7.3.10 Timing Requirements

Figure 24 shows a detailed timing diagram for the three-wire serial control interface. These timing parameters are critical for proper control port operation.

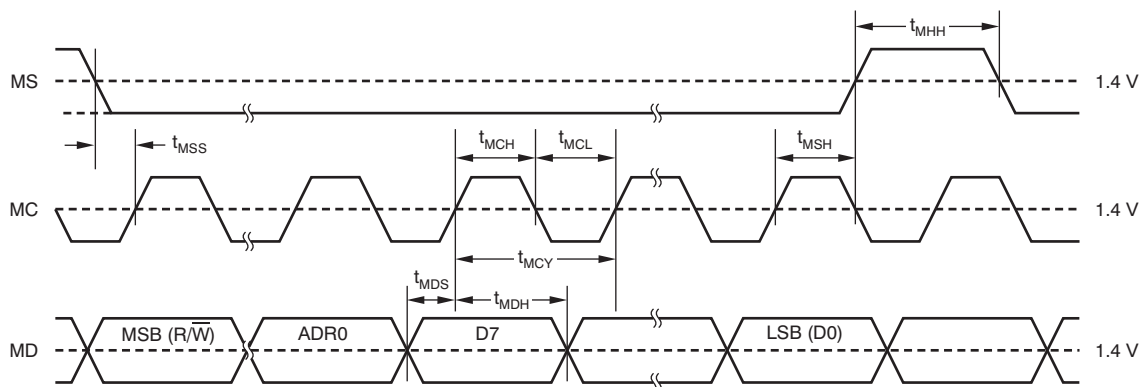

Figure 24. Three-Wire Serial Control Interface Timing

7.3.11 Two-wire (I<sup>2</sup>C) Serial Control

The PCM1789 supports an I<sup>2</sup>C-compatible serial bus and data transmission protocol for fast mode configured as a slave device. This protocol is explained in the I<sup>2</sup>C specification 2.0.

The PCM1789 has a 7-bit slave address, as shown in Figure 25. The first five bits are the most significant bits (MSBs) of the slave address and are factory-preset to 10011. The next two bits of the address byte are selectable bits that can be set by MS/ADR0/RSV and ADR5/ADR1/RSV. A maximum of four PCM1789s can be connected on the same bus at any one time. Each PCM1789 responds when it receives its own slave address.

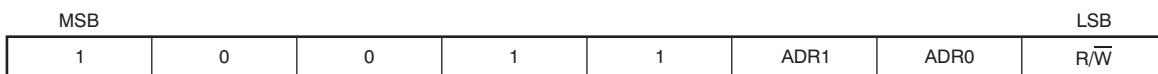
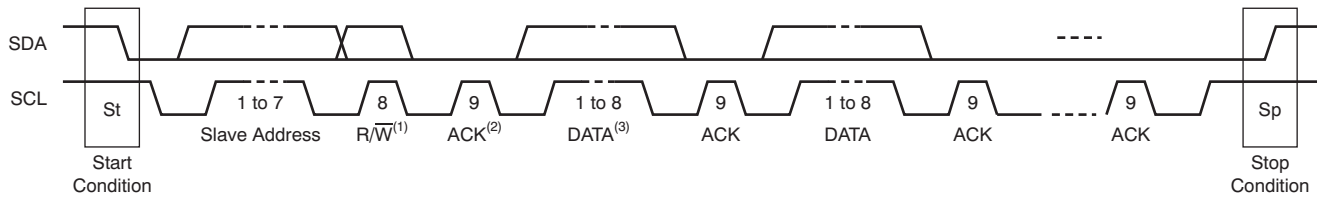

Figure 25. Slave Address

7.3.12 Packet Protocol

A master device must control the packet protocol, which consists of a start condition, a slave address with the read/write bit, data if a write operation is required, an acknowledgment if a read operation is required, and a stop condition. The PCM1789 supports both slave receiver and transmitter functions. Details about DATA for both write and read operations are described in Figure 26.



- (1) R/W: Read operation if 1; write operation otherwise.
- (2) ACK: Acknowledgment of a byte if 0, not Acknowledgment of a byte if 1.
- (3) DATA: Eight bits (byte); details are described in the [Write Operation](#) and [Read Operation](#) sections.

**Figure 26. I<sup>2</sup>C Packet Control Protocol**

### 7.3.13 Write Operation

The PCM1789 supports a receiver function. A master device can write to any PCM1789 register using single or multiple accesses. The master sends a PCM1789 slave address with a write bit, a register address, and the data. If multiple access is required, the address is that of the starting register, followed by the data to be transferred. When valid data are received, the index register automatically increments by one. When the register address reaches &h4F, the next value is &h40. When undefined registers are accessed, the PCM1789 does not send an acknowledgment. [Figure 27](#) illustrates a diagram of the write operation. The register address and write data are in 8-bit, MSB-first format.

Transmitter	M	M	M	S	M	S	M	S	M	S	...	S	M
Data Type	St	Slave Address	$\overline{W}$	ACK	Reg Address	ACK	Write Data 1	ACK	Write Data 2	ACK	...	ACK	Sp

NOTE: M = Master device, S = Slave device, St = Start condition,  $\overline{W}$  = Write, ACK = Acknowledge, and Sp = Stop condition.

**Figure 27. Framework for Write Operation**

### 7.3.14 Read Operation

A master device can read the registers of the PCM1789. The value of the register address is stored in an indirect index register in advance. The master sends the PCM1789 slave address with a read bit after storing the register address. Then the PCM1789 transfers the data that the index register points to. [Figure 28](#) shows a diagram of the read operation.

Transmitter	M	M	M	S	M	S	M	M	M	S	S	M	M
Data Type	St	Slave Address	$\overline{W}$	ACK	Reg Address	ACK	Sr	Slave Address <sup>(1)</sup>	R	ACK	Read Data	NACK	Sp

- (1) The slave address after the repeated start condition must be the same as the previous slave address.
- NOTE: M = Master device, S = Slave device, St = Start condition, Sr = Repeated start condition,  $\overline{W}$  = Write, R = Read, ACK = Acknowledge, NACK = Not acknowledge, and Sp = Stop condition.

**Figure 28. Framework for Read Operation**

## 7.4 Device Functional Modes

### 7.4.1 Sampling Mode

The PCM1789 supports three sampling modes (single rate, dual rate, and quad rate) in DAC operation. In single rate mode, the DAC operates at an oversampling frequency of x128 (except when SCK1 = 128 f<sub>S</sub> and 192 f<sub>S</sub>); this mode is supported for sampling frequencies less than 50 kHz. In dual rate mode, the DAC operates at an oversampling frequency of x64; this mode is supported for sampling frequencies less than 100 kHz. In quad rate mode, the DAC operates at an oversampling frequency of x32. The sampling mode is automatically selected according to the ratio of system clock frequency and sampling frequency by default (that is, single rate for 512 f<sub>S</sub>, 768 f<sub>S</sub>, and 1152 f<sub>S</sub>; dual rate for 256 f<sub>S</sub> and 384 f<sub>S</sub>; and quad rate for 128 f<sub>S</sub> and 192 f<sub>S</sub>), but manual selection is also possible for specified combinations through the serial mode control register.

Device Functional Modes (continued)

Table 3 and Figure 29 show the relationship among the oversampling rate (OSR) of the digital filter and  $\Delta\Sigma$  modulator, the noise-free shaped bandwidth, and each sampling mode setting.

Table 3. Digital Filter OSR, Modulator OSR, and Noise-Free Shaped Bandwidth for Each Sampling Mode

SAMPLING MODE REGISTER SETTING	SYSTEM CLOCK FREQUENCY ( $xf_s$ )	NOISE-FREE SHAPED BANDWIDTH <sup>(1)</sup> (kHz)			DIGITAL FILTER OSR	MODULATOR OSR
		$f_s = 48$ kHz	$f_s = 96$ kHz	$f_s = 192$ kHz		
Auto	512, 768, 1152	40	N/A	N/A	x8	x128
	256, 384	20	40	N/A	x8	x64
	128, 192 <sup>(2)</sup>	10	20	40	x4	x32
Single	512, 768, 1152	40	N/A	N/A	x8	x128
	256, 384	40	N/A	N/A	x8	x128
	128, 192 <sup>(2)</sup>	20	N/A	N/A	x4	x64
Dual	256, 384	20	40	N/A	x8	x64
	128, 192 <sup>(2)</sup>	20	40	N/A	x4	x64
Quad	128, 192 <sup>(2)</sup>	10	20	40	x4	x32

- (1) Bandwidth in which noise is shaped out.
- (2) Quad mode filter characteristic is applied.

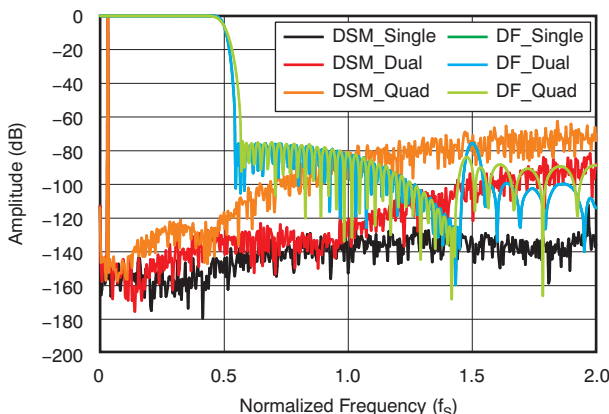

Figure 29.  $\Delta\Sigma$  Modulator and Digital Filter Characteristic

7.4.2 Audio Serial Port Operation

The PCM1789 audio serial port consists of three signals: BCK, LRCK, and DIN. BCK is a bit clock input. LRCK is a left/right word clock or frame synchronization clock input. DIN is the audio data input for VOULT/R.

7.4.3 Audio Data Interface Formats and Timing

The PCM1789 supports six audio data interface formats: 16-/20-/24-/32-bit I<sup>2</sup>S, 16-/20-/24-/32-bit left-justified, 24-bit right-justified, 16-bit right-justified, 24-bit left-justified mode DSP, and 24-bit I<sup>2</sup>S mode DSP. In the case of I<sup>2</sup>S, left-justified, and right-justified data formats, 64 BCKs, 48 BCKs, and 32 BCKs per LRCK period are supported; however, 48 BCKs are limited to 192/384/768  $f_s$  SCKI, and 32 BCKs are limited to 16-bit right-justified only. The audio data formats are selected by MC/SCL/FMT in hardware control mode and by the FMTDA[2:0] bits in control register 17 (11h) in software control mode. All data must be in binary twos complement and MSB first.

Table 4 summarizes the applicable formats and describes the relationships among them and the respective restrictions with mode control. Figure 30 through Figure 34 show six audio interface data formats.

**Table 4. Audio Data Interface Formats and Sampling Rate, Bit Clock, and System Clock Restrictions**

CONTROL MODE	FORMAT	DATA BITS	MAX LRCK FREQUENCY (f <sub>S</sub> )	SCKI RATE (xf <sub>S</sub> )	BCK RATE (xf <sub>S</sub> )
Software control	I <sup>2</sup> S/Left-Justified	16/20/24/32 <sup>(1)</sup>	192 kHz	128 to 1152 <sup>(2)</sup>	64, 48
	Right-Justified	24, 16	192 kHz	128 to 1152 <sup>(2)</sup>	64, 48, 32 (16 bit) <sup>(3)</sup>
	I <sup>2</sup> S/Left-Justified DSP	24	192 kHz	128 to 768	64
Hardware control	I <sup>2</sup> S/Left-Justified	16/20/24/32 <sup>(1)</sup>	192 kHz	128 to 1152 <sup>(2)</sup>	64, 48

- (1) 32-bit data length is acceptable only for BCK = 64 f<sub>S</sub> and when using I<sup>2</sup>S or Left-Justified format.
- (2) 1152 f<sub>S</sub> is acceptable only for f<sub>S</sub> = 32 kHz, BCK = 64 f<sub>S</sub>, and when using I<sup>2</sup>S, Left-Justified, or 24-bit Right-Justified format.
- (3) BCK = 32 f<sub>S</sub> is supported only for 16-bit data length.

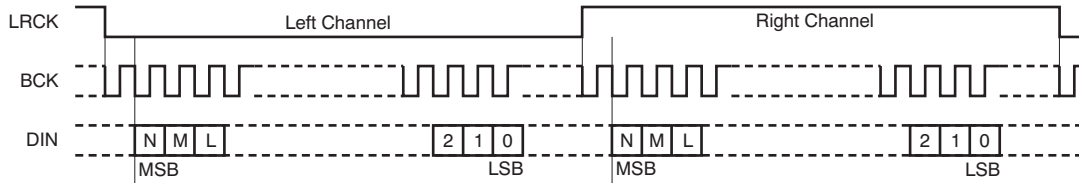

**Figure 30. Audio Data Format: 16-/20-/24-/32-Bit I<sup>2</sup>S**  
(N = 15/19/23/31, M = 14/18/22/30, and L = 13/17/21/29)

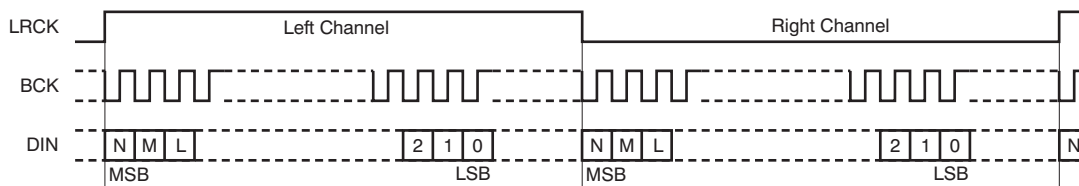

**Figure 31. Audio Data Format: 16-/20-/24-/32-Bit Left-Justified**  
(N = 15/19/23/31, M = 14/18/22/30, and L = 13/17/21/29)

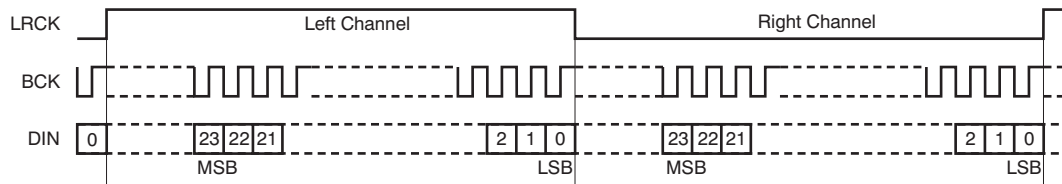

**Figure 32. Audio Data Format: 24-Bit Right-Justified**

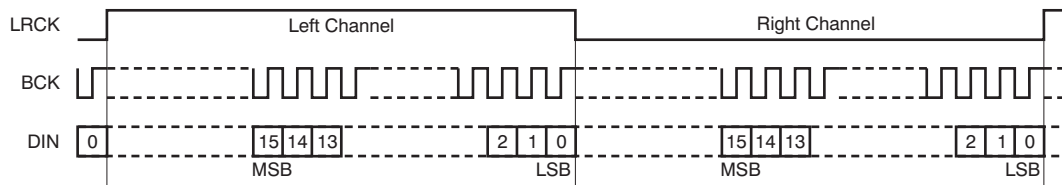

**Figure 33. Audio Data Format: 16-Bit Right-Justified**

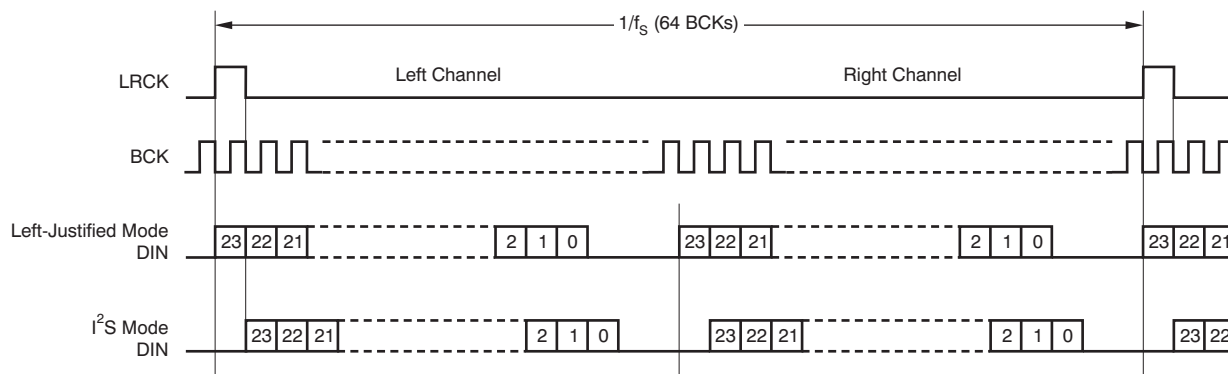

Figure 34. Audio Data Format: 24-Bit DSP Format

#### 7.4.4 Audio Interface Timing

Figure 35 and [Audio Interface Timing Requirements](#) describe the detailed audio interface timing specifications.

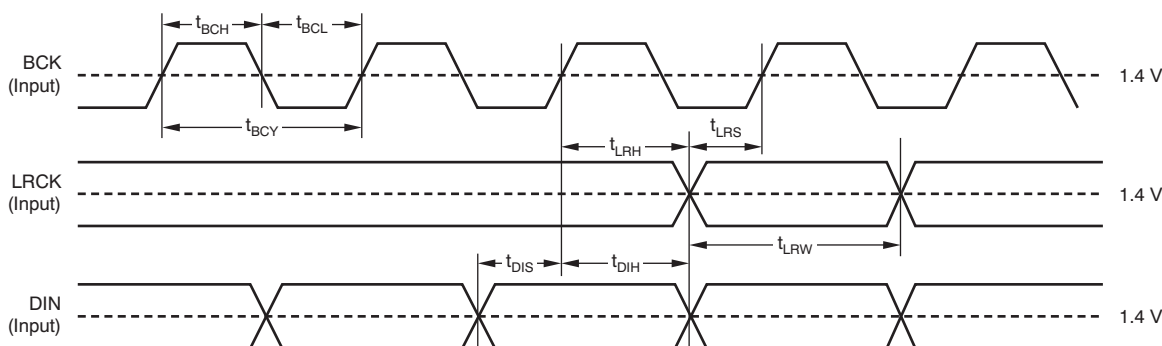

Figure 35. Audio Interface Timing Diagram for Left-Justified, Right-Justified, I²S, and DSP Data Formats

#### 7.4.5 Synchronization with the Digital Audio System

The PCM1789 operates under the system clock (SCKI) and the audio sampling rate (LRCK). Therefore, SCKI and LRCK must have a specific relationship. The PCM1789 does not need a specific phase relationship between the audio interface clocks (LRCK, BCK) and the system clock (SCKI), but does require a specific frequency relationship (ratiometric) between LRCK, BCK, and SCKI.

If the relationship between SCKI and LRCK changes more than  $\pm 2$  BCK clocks because of jitter, sampling frequency change, etc., the DAC internal operation stops within  $1/f_s$ , and the analog output is forced into VCOM (0.5 VCC1) until re-synchronization among SCKI, LRCK, and BCK completes, and then either  $38/f_s$  (single, dual rate) or  $29/f_s$  (quad rate) passes. In the event the change is less than  $\pm 2$  BCKs, re-synchronization does not occur, and this analog output control and discontinuity does not occur.

Figure 36 shows the DAC analog output during loss of synchronization. During undefined data periods, some noise may be generated in the audio signal. Also, the transition of normal to undefined data and undefined (or zero) data to normal data creates a discontinuity of data on the analog outputs, which may then generate some noise in the audio signal.

The DAC outputs (VOUTx) hold the previous state if the system clock halts, but the asynchronous and re-synchronization processes will occur after the system clock resumes.

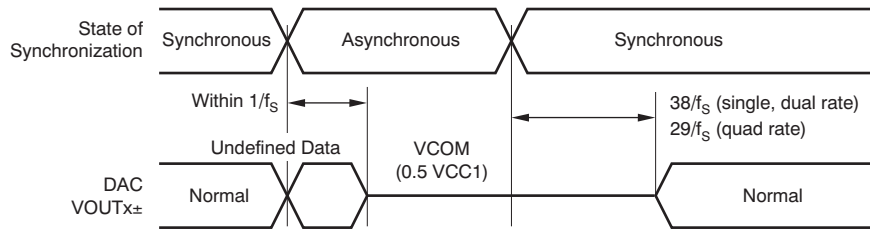

**Figure 36. DAC Outputs During Loss of Synchronization**

**7.4.6 MODE Control**

The PCM1789 includes three mode control interfaces with three oversampling configurations, depending on the input state of the MODE pin, as shown in Table 5. The pull-up and pull-down resistors must be 220 kΩ ±5%.

**Table 5. Interface Mode Control Selection**

MODE	MODE CONTROL INTERFACE
Tied to DGND	Two-wire (I <sup>2</sup> C) serial control, selectable oversampling configuration
Pull-down resistor to DGND	Two-wire parallel control, auto mode oversampling configuration
Pull-up resistor to VDD	Three-wire (SPI) serial control, selectable oversampling configuration, ADR6 = '0'
Tied to VDD	Three-wire (SPI) serial control, selectable oversampling configuration, ADR6 = '1'

The input state of the MODE pin is sampled at the moment of power-on, or during a low-to-high transition of the RST pin, with the system clock input. Therefore, input changes after reset are ignored until the next power-on or reset. From the mode control selection described in Table 5, the functions of four pins are changed, as shown in Table 6.

**Table 6. Pin Functions for Interface Mode**

PIN	PIN ASSIGNMENTS		
	SPI	I <sup>2</sup> C	H/W
21	MD (input)	SDA (input/output)	DEMP (input)
22	MC (input)	SCL (input)	FMT (input)
23	MS (input)	ADR0 (input)	RSV (input, low)
24	ADR5 (input)	ADR1 (input)	RSV (input, low)

In serial mode control, the actual mode control is performed by register writes (and reads) through the SPI- or I<sup>2</sup>C-compatible serial control port. In parallel mode control, two specific functions are controlled directly through the high/low control of two specific pins, as described in the following section.

**7.4.7 Parallel Hardware Control**

The functions shown in Table 7 and Table 8 are controlled by two pins, DEMP and FMT, in parallel hardware control mode. The DEMP pin controls the 44.1-kHz digital de-emphasis function of both channels. The FMT pin controls the audio interface format for both channels.

**Table 7. DEMP Functionality**

DEMP	DESCRIPTION
Low	De-emphasis off
High	44.1 kHz de-emphasis on

**Table 8. FMT Functionality**

FMT	DESCRIPTION
Low	16-/20-/24-/32-bit I <sup>2</sup> S format
High	16-/20-/24-/32-bit left-justified format

## 7.5 Register Maps

### 7.5.1 Control Register Definitions (Software Mode Only)

The PCM1789 has many user-programmable functions that are accessed via control registers, and are programmed through the SPI or I<sup>2</sup>C serial control port. [Table 9](#) shows the available mode control functions along with reset default conditions and associated register addresses. [Table 10](#) lists the register map.

**Table 9. User-Programmable Mode Control Functions**

FUNCTION	RESET DEFAULT	REGISTER <sup>(1)</sup>	LABEL
Mode control register reset	Normal operation	16	MRST
System reset	Normal operation	16	SRST
Analog mute function control	Mute disabled	16	AMUTE[3:0]
Sampling mode selection	Auto	16	SRDA[1:0]
Power-save mode selection	Power save	17	PSMDA
Audio interface format selection	I <sup>2</sup> S	17	FMTDA[2:0]
Operation control	Normal operation	18	OPEDA
Digital filter roll-off control	Sharp roll-off	18	FLT
Output phase selection	Normal	19	REVDA[2:1]
Soft mute control	Mute disabled	20	MUTDA[2:1]
Zero flag	Not detected	21	ZERO[2:1]
Digital attenuation mode	0 dB to –63 dB, 0.5-dB step	22	DAMS
Digital de-emphasis function control	Disabled	22	DEMP[1:0]
AMUTEO/ZERO flag selection	ZERO2	22	MZSEL
Zero flag function selection	ZERO1: left-channel ZERO2: right-channel	22	AZRO
Zero flag polarity selection	High for detection	22	ZREV
Digital attenuation level setting	0 dB, no attenuation	24, 25	ATDAX[7:0]

(1) If ADR6 or ADR5 is high, the register address must be changed to the number shown + offset; offset is 32, 64 and 96 according to state of ADR6, 5 (01, 10 and 11).

**Table 10. Register Map**

ADR[6:0] <sup>(1)</sup>		DATA[7:0]							
DEC	HEX	B7	B6	B5	B4	B3	B2	B1	B0
16	10	MRST	SRST	AMUTE3	AMUTE2	AMUTE1	AMUTE0	SRDA1	SRDA0
17	11	PSMDA	RSV <sup>(2)</sup>	RSV <sup>(2)</sup>	RSV <sup>(2)</sup>	RSV <sup>(2)</sup>	FMTDA2	FMTDA1	FMTDA0
18	12	RSV <sup>(2)</sup>	RSV <sup>(2)</sup>	RSV <sup>(2)</sup>	OPEDA	RSV <sup>(2)</sup>	RSV <sup>(2)</sup>	RSV <sup>(2)</sup>	FLT
19	13	RSV <sup>(2)</sup>	RSV <sup>(2)</sup>	RSV <sup>(2)</sup>	RSV <sup>(2)</sup>	RSV <sup>(2)</sup>	RSV <sup>(2)</sup>	REVDA2	REVDA1
20	14	RSV <sup>(2)</sup>	RSV <sup>(2)</sup>	RSV <sup>(2)</sup>	RSV <sup>(2)</sup>	RSV <sup>(2)</sup>	RSV <sup>(2)</sup>	MUTDA2	MUTDA1
21	15	RSV <sup>(2)</sup>	RSV <sup>(2)</sup>	RSV <sup>(2)</sup>	RSV <sup>(2)</sup>	RSV <sup>(2)</sup>	RSV <sup>(2)</sup>	ZERO2	ZERO1
22	16	DAMS	RSV <sup>(2)</sup>	DEMP1	DEMP0	MZSEL	RSV <sup>(2)</sup>	AZRO	ZREV
23	17	RSV <sup>(2)</sup>	RSV <sup>(2)</sup>	RSV <sup>(2)</sup>	RSV <sup>(2)</sup>	RSV <sup>(2)</sup>	RSV <sup>(2)</sup>	RSV <sup>(2)</sup>	RSV <sup>(2)</sup>
24	18	ATDA17	ATDA16	ATDA15	ATDA14	ATDA13	ATDA12	ATDA11	ATDA10
25	19	ATDA27	ATDA26	ATDA25	ATDA24	ATDA23	ATDA22	ATDA21	ATDA20

(1) If ADR6 or ADR5 is high, the register address must be changed to the number shown + offset; offset is 32, 64 and 96 according to state of ADR6, 5 (01, 10 and 11).

(2) RSV must be set to '0'.

## 7.5.2 Register Definitions

DEC	HEX	B7	B6	B5	B4	B3	B2	B1	B0
16	10	MRST	SRST	AMUTE3	AMUTE2	AMUTE1	AMUTE0	SRDA1	SRDA0
<b>MRST</b>		<b>Mode control register reset</b> This bit sets the mode control register reset to the default value. Pop noise may be generated. Returning the MRST bit to '1' is unnecessary because it is automatically set to '1' after the mode control register is reset. Default value = 1.							
		<b>MRST</b>	<b>Mode control register reset</b>						
		0	Set default value						
		1	Normal operation (default)						
<b>SRST</b>		<b>System reset</b> This bit controls the system reset, which includes the resynchronization between the system clock and sampling clock, and DAC operation restart. The mode control register is not reset and the PCM1789 does not go into a power-down state. Returning the SRST bit to '1' is unnecessary; it is automatically set to '1' after triggering a system reset. Default value = 1.							
		<b>SRST</b>	<b>System reset</b>						
		0	Resynchronization						
		1	Normal operation (default)						
<b>AMUTE[3:0]</b>		<b>Analog mute function control</b> These bits control the enabling/disabling of each source event that triggers the analog mute control circuit. Default value = 0000.							
		<b>AMUTE</b>	<b>Analog mute function control</b>						
		xxx0	Disable analog mute control by SCKI halt						
		xxx1	Enable analog mute control by SCKI halt						
		xx0x	Disable analog mute control by asynchronous detect						
		xx1x	Enable analog mute control by asynchronous detect						
		x0xx	Disable analog mute control by ZERO1 and ZERO2 detect						
		x1xx	Enable analog mute control by ZERO1 and ZERO2 detect						
		0xxx	Disable analog mute control by DAC disable command						
		1xxx	Enable analog mute control by DAC disable command						
<b>SRDA[1:0]</b>		<b>Sampling mode selection</b> These bits control the sampling mode of DAC operation. In Auto mode, the sampling mode is automatically set according to multiples between the system clock and sampling clock: single rate for 512 $f_s$ , 768 $f_s$ , and 1152 $f_s$ , dual rate for 256 $f_s$ or 384 $f_s$ , and quad rate for 128 $f_s$ and 192 $f_s$ . Default value = 00.							
		<b>SRDA</b>	<b>Sampling mode selection</b>						
		00	Auto (default)						
		01	Single rate						
		10	Dual rate						
		11	Quad rate						

DEC	HEX	B7	B6	B5	B4	B3	B2	B1	B0
17	11	PSMDA	RSV	RSV	RSV	RSV	FMTDA2	FMTDA1	FMTDA0
<b>PSMDA</b>		<b>Power-save mode selection</b> This bit selects the power-save mode for the OPEDA function. When PSMDA = 0, OPEDA controls the power-save mode and normal operation. When PSMDA = 1, OPEDA functions controls the DAC disable (not power-save mode) and normal operation. Default value: 0.							
		<b>PSMDA</b>	<b>Power-save mode selection</b>						
		0	Power-save enable mode (default)						
		1	Power-save disable mode						

<b>RSV</b>	<b>Reserved</b> Reserved; do not use.																		
<b>FMTDA[2:0]</b>	<b>Audio interface format selection</b> These bits control the audio interface format for DAC operation. Details of the format and any related restrictions with the system clock are described in the <a href="#">Audio Data Interface Formats and Timing</a> section. Default value: 0000 (16-/20-/24-/32-bit I <sup>2</sup> S format).																		
	<table border="1"> <thead> <tr> <th>FMTDA</th> <th>Audio interface format selection</th> </tr> </thead> <tbody> <tr> <td>000</td> <td>16-/20-/24-/32-bit I<sup>2</sup>S format (default)</td> </tr> <tr> <td>001</td> <td>16-/20-/24-/32-bit left-justified format</td> </tr> <tr> <td>010</td> <td>24-bit right-justified format</td> </tr> <tr> <td>011</td> <td>16-bit right-justified format</td> </tr> <tr> <td>100</td> <td>24-bit I<sup>2</sup>S mode DSP format</td> </tr> <tr> <td>101</td> <td>24-bit left-justified mode DSP format</td> </tr> <tr> <td>110</td> <td>Reserved</td> </tr> <tr> <td>111</td> <td>Reserved</td> </tr> </tbody> </table>	FMTDA	Audio interface format selection	000	16-/20-/24-/32-bit I <sup>2</sup> S format (default)	001	16-/20-/24-/32-bit left-justified format	010	24-bit right-justified format	011	16-bit right-justified format	100	24-bit I <sup>2</sup> S mode DSP format	101	24-bit left-justified mode DSP format	110	Reserved	111	Reserved
FMTDA	Audio interface format selection																		
000	16-/20-/24-/32-bit I <sup>2</sup> S format (default)																		
001	16-/20-/24-/32-bit left-justified format																		
010	24-bit right-justified format																		
011	16-bit right-justified format																		
100	24-bit I <sup>2</sup> S mode DSP format																		
101	24-bit left-justified mode DSP format																		
110	Reserved																		
111	Reserved																		

DEC	HEX	B7	B6	B5	B4	B3	B2	B1	B0
18	12	RSV	RSV	RSV	OPEDA	RSV	RSV	RSV	FLT

<b>RSV</b>	<b>Reserved</b> Reserved; do not use.						
<b>OPEDA</b>	<b>Operation control</b> This bit controls the DAC operation mode. In operation disable mode, the DAC output is cut off from DIN and the internal DAC data are reset. If PSMDA = 1, the DAC output is forced into VCOM. If PSMDA = 0, the DAC output is forced into AGND and the DAC goes into a power-down state. For normal operating mode, this bit must be '0'. The serial mode control is effective during operation disable mode. Default value: 0.						
	<table border="1"> <thead> <tr> <th>OPEDA</th> <th>Operation control</th> </tr> </thead> <tbody> <tr> <td>0</td> <td>Normal operation</td> </tr> <tr> <td>1</td> <td>Operation disable with or without power save</td> </tr> </tbody> </table>	OPEDA	Operation control	0	Normal operation	1	Operation disable with or without power save
OPEDA	Operation control						
0	Normal operation						
1	Operation disable with or without power save						
<b>FLT</b>	<b>Digital filter roll-off control</b> This bit allows users to select the digital filter roll-off that is best suited to their applications. Sharp and slow filter roll-off selections are available. The filter responses for these selections are shown in the <a href="#">Typical Characteristics</a> sections of this data sheet. Default value: 0.						
	<table border="1"> <thead> <tr> <th>FLT</th> <th>Digital filter roll-off control</th> </tr> </thead> <tbody> <tr> <td>0</td> <td>Sharp roll-off</td> </tr> <tr> <td>1</td> <td>Slow roll-off</td> </tr> </tbody> </table>	FLT	Digital filter roll-off control	0	Sharp roll-off	1	Slow roll-off
FLT	Digital filter roll-off control						
0	Sharp roll-off						
1	Slow roll-off						

DEC	HEX	B7	B6	B5	B4	B3	B2	B1	B0
19	13	RSV	RSV	RSV	RSV	RSV	RSV	REVDA2	REVDA1

<b>RSV</b>	<b>Reserved</b> Reserved; do not use.										
<b>REVDA[2:1]</b>	<b>Output phase selection</b> These bits are used to control the phase of the DAC analog signal outputs. Default value: 00.										
	<table border="1"> <thead> <tr> <th>REVDA</th> <th>Output phase selection</th> </tr> </thead> <tbody> <tr> <td>x0</td> <td>Left channel normal output</td> </tr> <tr> <td>x1</td> <td>Left channel inverted output</td> </tr> <tr> <td>0x</td> <td>Right channel normal output</td> </tr> <tr> <td>1x</td> <td>Right channel inverted output</td> </tr> </tbody> </table>	REVDA	Output phase selection	x0	Left channel normal output	x1	Left channel inverted output	0x	Right channel normal output	1x	Right channel inverted output
REVDA	Output phase selection										
x0	Left channel normal output										
x1	Left channel inverted output										
0x	Right channel normal output										
1x	Right channel inverted output										

DEC	HEX	B7	B6	B5	B4	B3	B2	B1	B0
20	14	RSV	RSV	RSV	RSV	RSV	RSV	MUTDA2	MUTDA1
<b>RSV</b>	<b>Reserved</b> Reserved; do not use.								
<b>MUTDA[2:1]</b>	<b>Soft Mute control</b> These bits are used to enable or disable the Soft Mute function for the corresponding DAC outputs, VOUTx. The Soft Mute function is incorporated into the digital attenuators. When mute is disabled (MUTDA[2:1] = 0), the attenuator and DAC operate normally. When mute is enabled by setting MUTDA[2:1] = 1, the digital attenuator for the corresponding output is decreased from the current setting to infinite attenuation. By setting MUTDA[2:1] = 0, the attenuator is increased to the last attenuation level in the same manner as it is for decreasing levels. This configuration reduces <i>pop and zipper noise</i> during muting of the DAC output. This Soft Mute control uses the same resource of digital attenuation level setting. Mute control has priority over the digital attenuation level setting. Default value: 00.								
	<b>MUTDA</b>	<b>Soft Mute control</b>							
	x0	Left channel mute disabled							
	x1	Left channel mute enabled							
	0x	Right channel mute disabled							
	1x	Right channel mute enabled							

DEC	HEX	B7	B6	B5	B4	B3	B2	B1	B0
21	15	RSV	RSV	RSV	RSV	RSV	RSV	ZERO2	ZERO1
<b>RSV</b>	<b>Reserved</b> Reserved; do not use.								
<b>ZERO[2:1]</b>	<b>Zero flag (read-only)</b> These bits indicate the present status of the zero detect circuit for each DAC channel; these bits are read-only.								
	<b>ZERO</b>	<b>Zero flag</b>							
	x0	Left channel zero input not detected							
	x1	Left channel zero input detected							
	0x	Right channel zero input not detected							
	1x	Right channel zero input detected							

DEC	HEX	B7	B6	B5	B4	B3	B2	B1	B0
22	16	DAMS	RSV	DEMP1	DEMP0	MZSEL	RSV	AZRO	ZREV
<b>DAMS</b>	<b>Digital attenuation mode</b> This bit selects the attenuation mode. Default value: 0.								
	<b>DAMS</b>	<b>Digital attenuation mode</b>							
	0	Fine step: 0.5-dB step for 0 dB to –63 dB range (default)							
	1	Wide range: 1-dB step for 0 dB to –100 dB range							
<b>RSV</b>	<b>Reserved</b> Reserved; do not use.								
<b>DEMP[1:0]</b>	<b>Digital de-emphasis function/sampling rate control</b> These bits are used to disable and enable the various sampling frequencies of the digital de-emphasis function. Default value: 00.								
	<b>DEMP</b>	<b>Digital de-emphasis function/sampling rate control</b>							
	00	Disable (default)							
	01	48 kHz enable							
	10	44.1 kHz enable							
	11	32 kHz enable							
<b>MZSEL</b>	<b>AMUTE0/ZERO flag selection</b> This bit is used to select the function of the ZERO2 pin.								

	Default value: 0.	
	<b>MZSEL</b>	<b>AMUTEO/ZERO flag selection</b>
	0	The ZERO2 pin functions as ZERO2 (default).
	1	The ZERO2 pin functions as AMUTEO.
<b>AZRO</b>	<b>Zero flag channel combination selection</b>	
	This bit is used to select the zero flag channel combination for ZERO1 and ZERO2.	
	Default value: 0.	
	<b>AZRO</b>	<b>Zero flag combination selection</b>
	0	Combination A: ZERO1 = left channel, ZERO2 = right channel (default)
	1	Combination B: ZERO1 = left channel or right channel, ZERO2 = left channel and right channel
<b>ZREV</b>	<b>Zero flag polarity selection</b>	
	This bit controls the polarity of the zero flag pin.	
	Default value: 0.	
	<b>ZREV</b>	<b>Zero flag polarity selection</b>
	0	High for zero detect (default)
	1	Low for zero detect

DEC	HEX	B7	B6	B5	B4	B3	B2	B1	B0
23	17	RSV	RSV	RSV	RSV	RSV	RSV	RSV	RSV
24	18	ATDA17	ATDA16	ATDA15	ATDA14	ATDA13	ATDA12	ATDA11	ATDA10
25	19	ATDA27	ATDA26	ATDA25	ATDA24	ATDA23	ATDA22	ATDA21	ATDA20

<b>RSV</b>	<b>Reserved</b> Reserved; do not use.
<b>ATDAx[7:0]</b>	<p><b>Digital attenuation level setting</b></p> <p>Where <math>x = 1</math> to 2, corresponding to the DAC output (VOUT<math>x</math>).</p> <p>Both DAC outputs (VOUTL and VOUTR) have a digital attenuation function. The attenuation level can be set from 0 dB to R dB, in S-dB steps. Changes in attenuator levels are made by incrementing or decrementing one step (S dB) for every <math>8/f_S</math> time interval until the programmed attenuator setting is reached. Alternatively, the attenuation level can be set to infinite attenuation (or mute). R (range) and S (step) is –63 and 0.5 for DAMS = 0, and –100 and 1.0 for DAMS = 1, respectively. The DAMS bit is defined in register 22 (16h). <a href="#">Table 11</a> shows attenuation levels for various settings.</p> <p>The attenuation level for each channel can be set individually using the following formula:</p> $\text{Attenuation level (dB)} = S \times (\text{ATDAx}[7:0]_{\text{DEC}} - 255)$ <p>where <math>\text{ATDAx}[7:0]_{\text{DEC}} = 0</math> through 255.</p> <p>For <math>\text{ATDAx}[7:0]_{\text{DEC}} = 0</math> through 128 with DAMS = 0, or 0 through 154 with DAMS = 1, attenuation is set to infinite attenuation (mute).</p> <p>Default value: 1111 1111.</p>

**Table 11. Attenuation Levels for Various Settings**

ATDAx[7:0]		ATTENUATION LEVEL SETTING	
BINARY	DECIMAL	DAMS = 0	DAMS = 1
1111 1111	255	0 dB, no attenuation (default)	0 dB, no attenuation (default)
1111 1110	254	–0.5 dB	–1 dB
1111 1101	253	–1.0 dB	–2 dB
...	...	...	...
1001 1100	156	–45.9 dB	–99 dB
1001 1011	155	–50.0 dB	–100 dB
1001 1010	154	–50.5 dB	Mute
...	...	...	...
1000 0010	130	–62.5 dB	Mute
1000 0001	129	–63.0 dB	Mute
0000 0000	128	Mute	Mute
...	...	...	...
0000 0000	0	Mute	Mute

## 8 Application and Implementation

### NOTE

Information in the following applications sections is not part of the TI component specification, and TI does not warrant its accuracy or completeness. TI's customers are responsible for determining suitability of components for their purposes. Customers should validate and test their design implementation to confirm system functionality.

### 8.1 Application Information

#### 8.1.1 Connection Diagrams

A basic connection diagram is shown in [Figure 39](#), with the necessary power-supply bypassing and decoupling components. Texas Instruments' [PLL170X](#) is used to generate the system clock input at SCKI, as well as to generate the clock for the audio signal processor. The use of series resistors (22  $\Omega$  to 100  $\Omega$ ) are recommended for SCKI, LRCK, BCK, and DIN for electromagnetic interference (EMI) reduction.

#### 8.1.2 Power Supply and Grounding

The PCM1789 requires +5 V for the analog supply and +3.3 V for the digital supply. The +5-V supply is used to power the DAC analog and output filter circuitry, and the +3.3-V supply is used to power the digital filter and serial interface circuitry. For best performance, it is recommended to use a linear regulator (such as the [REG101-5/33](#), [REG102-5/33](#), or [REG103-5/33](#)) with the +5-V and +3.3-V supplies.

Five capacitors are required for supply bypassing, as shown in [Figure 39](#). These capacitors should be located as close as possible to the PCM1789 package. The 10- $\mu$ F capacitors are aluminum electrolytic, while the three 1- $\mu$ F capacitors are ceramic.

#### 8.1.3 Low-Pass Filter and Differential-to-Single-Ended Converter For DAC Outputs

$\Delta\Sigma$  DACs use noise-shaping techniques to improve in-band signal-to-noise ratio (SNR) performance at the expense of generating increased out-of-band noise above the Nyquist frequency, or  $f_s/2$ . The out-of-band noise must be low-pass filtered in order to provide optimal converter performance. This filtering is accomplished by a combination of on-chip and external low-pass filters.

[Figure 37](#) and [Figure 38](#) show the recommended external differential-to-single-ended converter with low-pass active filter circuits for ac-coupled and dc-coupled applications. These circuits are second-order Butterworth filters using a multiple feedback (MFB) circuit arrangement that reduces sensitivity to passive component variations over frequency and temperature. For more information regarding MFB active filter designs, please refer to Applications Bulletin [SBAA055](#), *Dynamic Performance Testing of Digital Audio D/A Converters*, available from the TI web site ([www.ti.com](http://www.ti.com)) or your local Texas Instruments' sales office.

Because the overall system performance is defined by the quality of the DACs and the associated analog output circuitry, high-quality audio op amps are recommended for the active filters. Texas Instruments' [OPA2134](#), [OPA2353](#), and [NE5532A](#) dual op amps are shown in [Figure 37](#) and [Figure 38](#), and are recommended for use with the PCM1789.

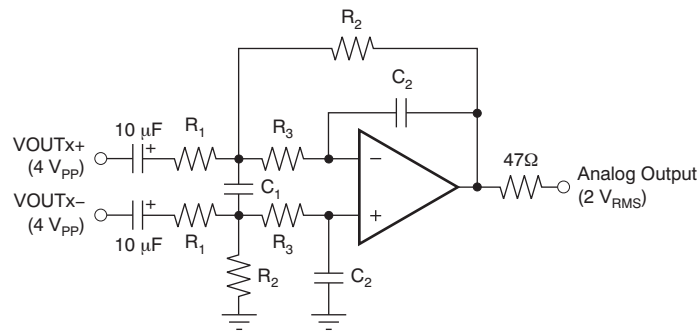
**Application Information (continued)**

NOTE: Amplifier is an NE5532A x 1/2 or OPA2134 x1/2;  $R_1 = 7.5 \text{ k}\Omega$ ;  $R_2 = 5.6 \text{ k}\Omega$ ;  $R_3 = 360 \text{ }\Omega$ ;  $C_1 = 3300 \text{ pF}$ ;  $C_2 = 680 \text{ pF}$ ; Gain = 0.747;  
 $f_{-3 \text{ dB}} = 53 \text{ kHz}$ .

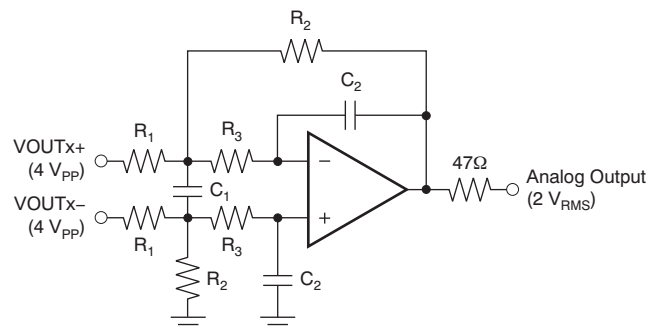
**Figure 37. AC-Coupled, Post-LPF and Differential to Single-Ended Buffer**

NOTE: Amplifier is an NE5532A x 1/2 or OPA2134 x1/2;  $R_1 = 15 \text{ k}\Omega$ ;  $R_2 = 11 \text{ k}\Omega$ ;  $R_3 = 820 \text{ }\Omega$ ;  $C_1 = 1500 \text{ pF}$ ;  $C_2 = 330 \text{ pF}$ ; Gain = 0.733;  
 $f_{-3 \text{ dB}} = 54 \text{ kHz}$ .

**Figure 38. DC-Coupled, Post-LPF and Differential to Single-Ended Buffer**

## 8.2 Typical Application

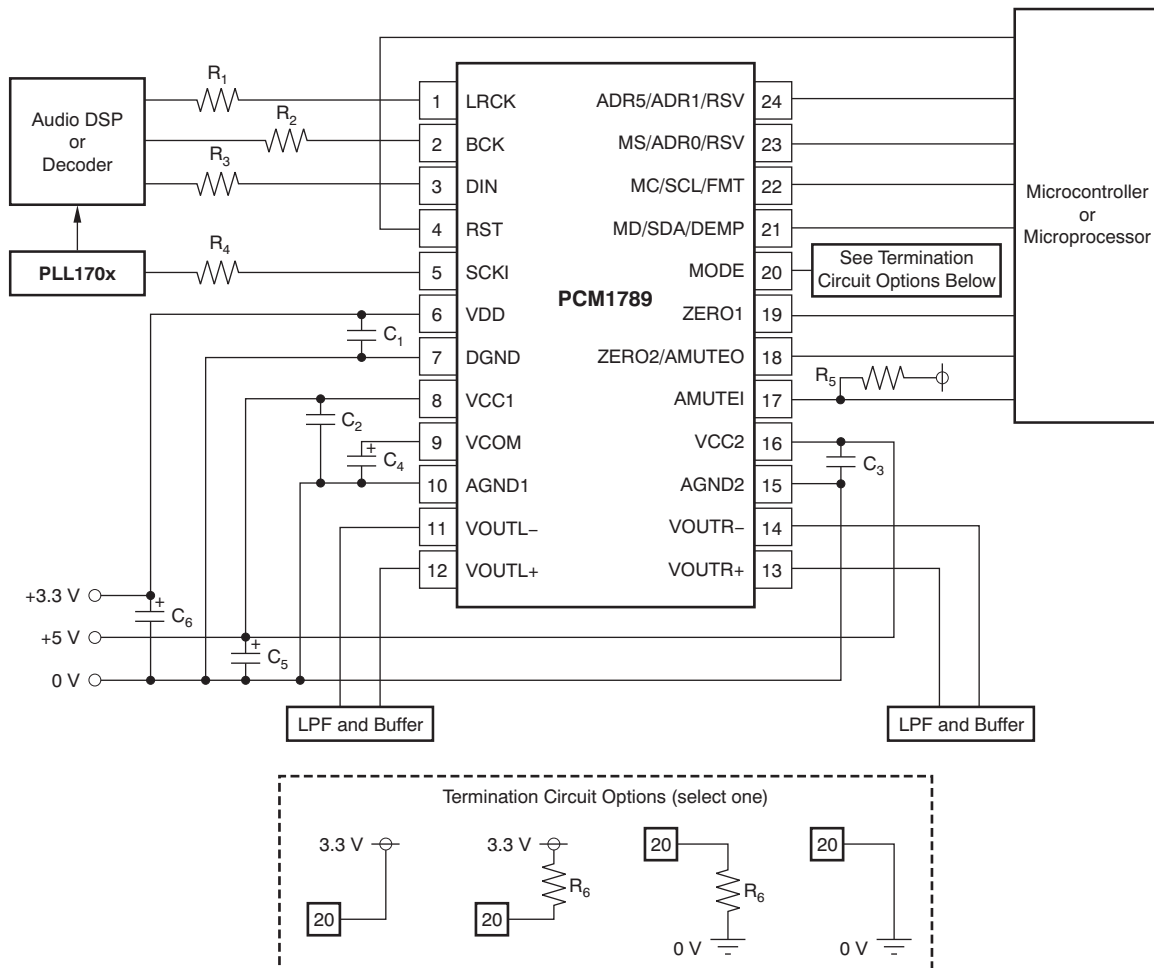

NOTE: C<sub>1</sub> through C<sub>3</sub> are 1- $\mu$ F ceramic capacitors. C<sub>4</sub> through C<sub>6</sub> are 10- $\mu$ F electrolytic capacitors. R<sub>1</sub> through R<sub>4</sub> are 22- $\Omega$  to 100- $\Omega$  resistors. R<sub>5</sub> is a resistor appropriate for pull-up. R<sub>6</sub> is a 220-k $\Omega$  resistor,  $\pm$ 5%. An appropriate resistor is required for pull-up, if ZERO2/AMUTE0 pin is used as AMUTE0.

Figure 39. Basic Connection Diagram

### 8.2.1 Design Requirements

- Control: Hardware, I<sup>2</sup>C, or SPI
- Audio Input: PCM Serial Data, TDM, or DSP
- Audio Output: (1.6  $\times$  VCC1) Vpp Analog Audio Biased to (0.5  $\times$  VCC1) V
- Master Clock: PLL170X IC

### 8.2.2 Detailed Design Procedure

#### 8.2.2.1 Hardware Control Method

There are 3 ways to control the PCM1789, hardware control, SPI, or I<sup>2</sup>C. Hardware control will provide a limited access to control features available in the PCM1789 but can be implemented with pull up and pull downs, or with GPIO of a microcontroller. Control via SPI or I<sup>2</sup>C will provide access to all control registers and features but will require a digital device that can implement SPI or I<sup>2</sup>C.

## Typical Application (continued)

### 8.2.2.2 Audio Input

For Audio Input there are 3 options, PCM serial data, TDM, or DSP. All three will support the same quality of audio data, but having these 3 options to match the audio sources available outputs allows for greater flexibility. This selection is made by configuring the MODE pin which is detailed in [Table 9](#) and shown in .

### 8.2.2.3 Audio Output

The output of the PCM1789 will produce a differential ( $1.6 \times V_{CC1}$ ) Vpp signal at full scale into a 5-k $\Omega$  load, that should be filtered before being sent to an amplifier. Outputs  $V_{OUT1}$  through  $V_{OUT8}$  will be biased at  $(0.5 \times V_{CC1})$  V.

### 8.2.2.4 Master Clock

The master clock can come from wither a dedicated IC such as the PLL170X series, a crystal or the audio source IC. What is important is that the audio source and the PCM1789 are driven from the same source so that the audio clocks will be synchronous.

## 8.3 Application Curve

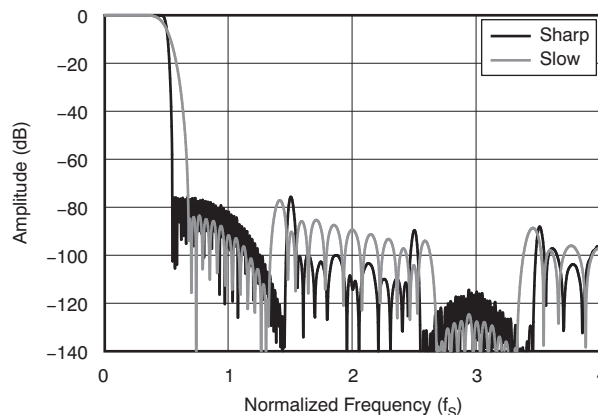

**Figure 40. Frequency Response (Single Rate)**

## 9 Power Supply Recommendations

The PCM1789 requires 5 V for the analog supply and 3.3 V for the digital supply. The +5-V supply is used to power the DAC analog and output filter circuitry, and the +3.3-V supply is used to power the digital filter and serial interface circuitry. For best performance, it is recommended to use a linear regulator (such as the [REG101-5/33](#), [REG102-5/33](#), or [REG103-5/33](#)) with the +5-V and +3.3-V supplies.

Five capacitors are required for supply bypassing, as shown in [Figure 39](#). These capacitors should be located as close as possible to the PCM1789 package. The 10- $\mu$ F capacitors are aluminum electrolytic, while the three 1- $\mu$ F capacitors are ceramic.

## 10 Layout

### 10.1 Layout Guidelines

A typical printed circuit board (PCB) layout for the PCM1789 is shown in Figure 41. A ground plane is recommended, with the analog and digital sections being isolated from one another using a split or cut in the circuit board. The PCM1789 should be oriented with the digital I/O pins facing the ground plane split/cut to allow for short, direct connections to the digital audio interface and control signals originating from the digital section of the board.

Separate power supplies are recommended for the digital and analog sections of the board. This configuration prevents the switching noise present on the digital supply from contaminating the analog power supply and degrading the dynamic performance of the PCM1789.

### 10.2 Layout Example

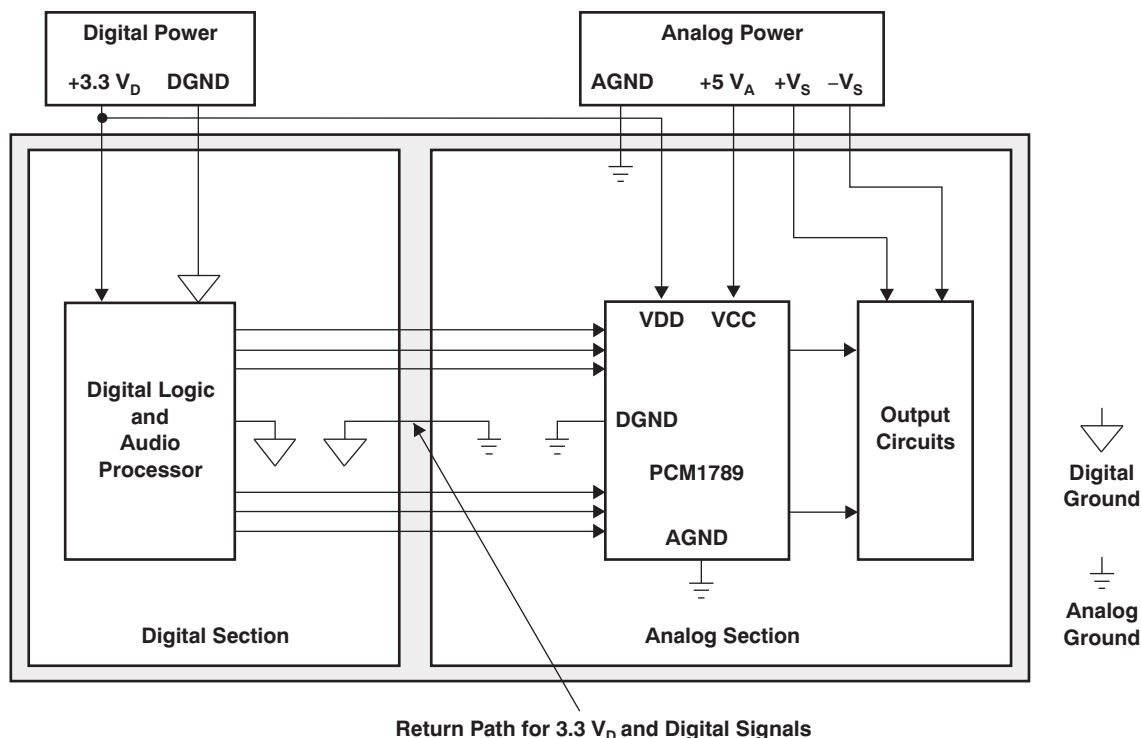

Figure 41. Recommended PCB Layout

## 11 Device and Documentation Support

### 11.1 Documentation Support

#### 11.1.1 Related Documentation

For related documentation, see the following:

- *Dynamic Performance Testing of Digital Audio D/A Converters*, [SBAA055](#)
- *PLL1700 3.3-V Dual-PLL Multiclock Generator*, [SBOS096](#)
- *REG101 DMOS 100 mA Low-Dropout Regulator*, [SBVS026](#)
- *REG102 DMOS 250 mA Low-Dropout Regulator*, [SBVS024](#)
- *REG103 DMOS 500 mA Low-Dropout Regulator*, [SBVS010](#)
- *OPAx134 SoundPlus™ High Performance Audio Operational Amplifiers*, [SBOS058](#)
- *OPAx353 High-Speed, Single-Supply, Rail-to-Rail Op Amps MicroAmplifier™ Series*, [SBOS103](#)
- *NE5532x, SA5532x Dual Low-Noise Operational Amplifiers*, [SLOS075](#)

### 11.2 Community Resources

The following links connect to TI community resources. Linked contents are provided "AS IS" by the respective contributors. They do not constitute TI specifications and do not necessarily reflect TI's views; see TI's [Terms of Use](#).

**TI E2E™ Online Community** *TI's Engineer-to-Engineer (E2E) Community*. Created to foster collaboration among engineers. At [e2e.ti.com](#), you can ask questions, share knowledge, explore ideas and help solve problems with fellow engineers.

**Design Support** *TI's Design Support* Quickly find helpful E2E forums along with design support tools and contact information for technical support.

### 11.3 Trademarks

E2E is a trademark of Texas Instruments.  
 Blu-ray Disc is a trademark of Blu-ray Disc Association.  
 All other trademarks are the property of their respective owners.

### 11.4 Electrostatic Discharge Caution



These devices have limited built-in ESD protection. The leads should be shorted together or the device placed in conductive foam during storage or handling to prevent electrostatic damage to the MOS gates.

### 11.5 Glossary

[SLYZ022](#) — *TI Glossary*.

This glossary lists and explains terms, acronyms, and definitions.

## 12 Mechanical, Packaging, and Orderable Information

The following pages include mechanical, packaging, and orderable information. This information is the most current data available for the designated devices. This data is subject to change without notice and revision of this document. For browser-based versions of this data sheet, refer to the left-hand navigation.

**PACKAGING INFORMATION**

Orderable Device	Status (1)	Package Type	Package Drawing	Pins	Package Qty	Eco Plan (2)	Lead finish/ Ball material (6)	MSL Peak Temp (3)	Op Temp (°C)	Device Marking (4/5)	Samples
PCM1789PW	ACTIVE	TSSOP	PW	24	60	RoHS & Green	NIPDAU	Level-2-260C-1 YEAR	-40 to 85	PCM1789	<a href="#">Samples</a>
PCM1789PWR	ACTIVE	TSSOP	PW	24	2000	RoHS & Green	NIPDAU	Level-2-260C-1 YEAR	-40 to 85	PCM1789	<a href="#">Samples</a>

(1) The marketing status values are defined as follows:

**ACTIVE:** Product device recommended for new designs.

**LIFEBUY:** TI has announced that the device will be discontinued, and a lifetime-buy period is in effect.

**NRND:** Not recommended for new designs. Device is in production to support existing customers, but TI does not recommend using this part in a new design.

**PREVIEW:** Device has been announced but is not in production. Samples may or may not be available.

**OBSOLETE:** TI has discontinued the production of the device.

(2) **RoHS:** TI defines "RoHS" to mean semiconductor products that are compliant with the current EU RoHS requirements for all 10 RoHS substances, including the requirement that RoHS substance do not exceed 0.1% by weight in homogeneous materials. Where designed to be soldered at high temperatures, "RoHS" products are suitable for use in specified lead-free processes. TI may reference these types of products as "Pb-Free".

**RoHS Exempt:** TI defines "RoHS Exempt" to mean products that contain lead but are compliant with EU RoHS pursuant to a specific EU RoHS exemption.

**Green:** TI defines "Green" to mean the content of Chlorine (Cl) and Bromine (Br) based flame retardants meet JS709B low halogen requirements of <=1000ppm threshold. Antimony trioxide based flame retardants must also meet the <=1000ppm threshold requirement.

(3) MSL, Peak Temp. - The Moisture Sensitivity Level rating according to the JEDEC industry standard classifications, and peak solder temperature.

(4) There may be additional marking, which relates to the logo, the lot trace code information, or the environmental category on the device.

(5) Multiple Device Markings will be inside parentheses. Only one Device Marking contained in parentheses and separated by a "~" will appear on a device. If a line is indented then it is a continuation of the previous line and the two combined represent the entire Device Marking for that device.

(6) Lead finish/Ball material - Orderable Devices may have multiple material finish options. Finish options are separated by a vertical ruled line. Lead finish/Ball material values may wrap to two lines if the finish value exceeds the maximum column width.

**Important Information and Disclaimer:**The information provided on this page represents TI's knowledge and belief as of the date that it is provided. TI bases its knowledge and belief on information provided by third parties, and makes no representation or warranty as to the accuracy of such information. Efforts are underway to better integrate information from third parties. TI has taken and continues to take reasonable steps to provide representative and accurate information but may not have conducted destructive testing or chemical analysis on incoming materials and chemicals. TI and TI suppliers consider certain information to be proprietary, and thus CAS numbers and other limited information may not be available for release.

In no event shall TI's liability arising out of such information exceed the total purchase price of the TI part(s) at issue in this document sold by TI to Customer on an annual basis.

**OTHER QUALIFIED VERSIONS OF PCM1789 :**

- Automotive : [PCM1789-Q1](#)

## NOTE: Qualified Version Definitions:

- Automotive - Q100 devices qualified for high-reliability automotive applications targeting zero defects

**TAPE AND REEL INFORMATION**

**QUADRANT ASSIGNMENTS FOR PIN 1 ORIENTATION IN TAPE**



\*All dimensions are nominal

Device	Package Type	Package Drawing	Pins	SPQ	Reel Diameter (mm)	Reel Width W1 (mm)	A0 (mm)	B0 (mm)	K0 (mm)	P1 (mm)	W (mm)	Pin1 Quadrant
PCM1789PWR	TSSOP	PW	24	2000	330.0	16.4	6.95	8.3	1.6	8.0	16.0	Q1

**TAPE AND REEL BOX DIMENSIONS**

\*All dimensions are nominal

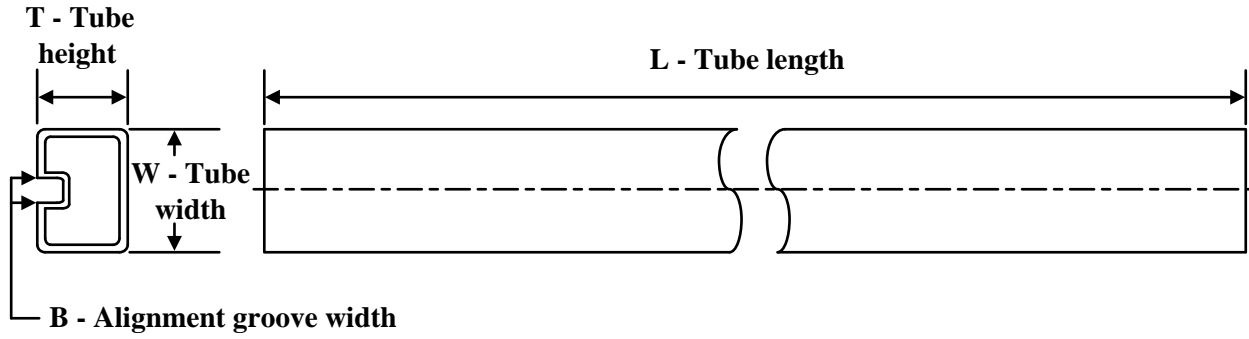
Device	Package Type	Package Drawing	Pins	SPQ	Length (mm)	Width (mm)	Height (mm)
PCM1789PWR	TSSOP	PW	24	2000	350.0	350.0	43.0

**TUBE**

\*All dimensions are nominal

Device	Package Name	Package Type	Pins	SPQ	L (mm)	W (mm)	T (μm)	B (mm)
PCM1789PW	PW	TSSOP	24	60	530	10.2	3600	3.5

PW0024A

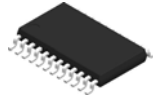

# PACKAGE OUTLINE

## TSSOP - 1.2 mm max height

SMALL OUTLINE PACKAGE

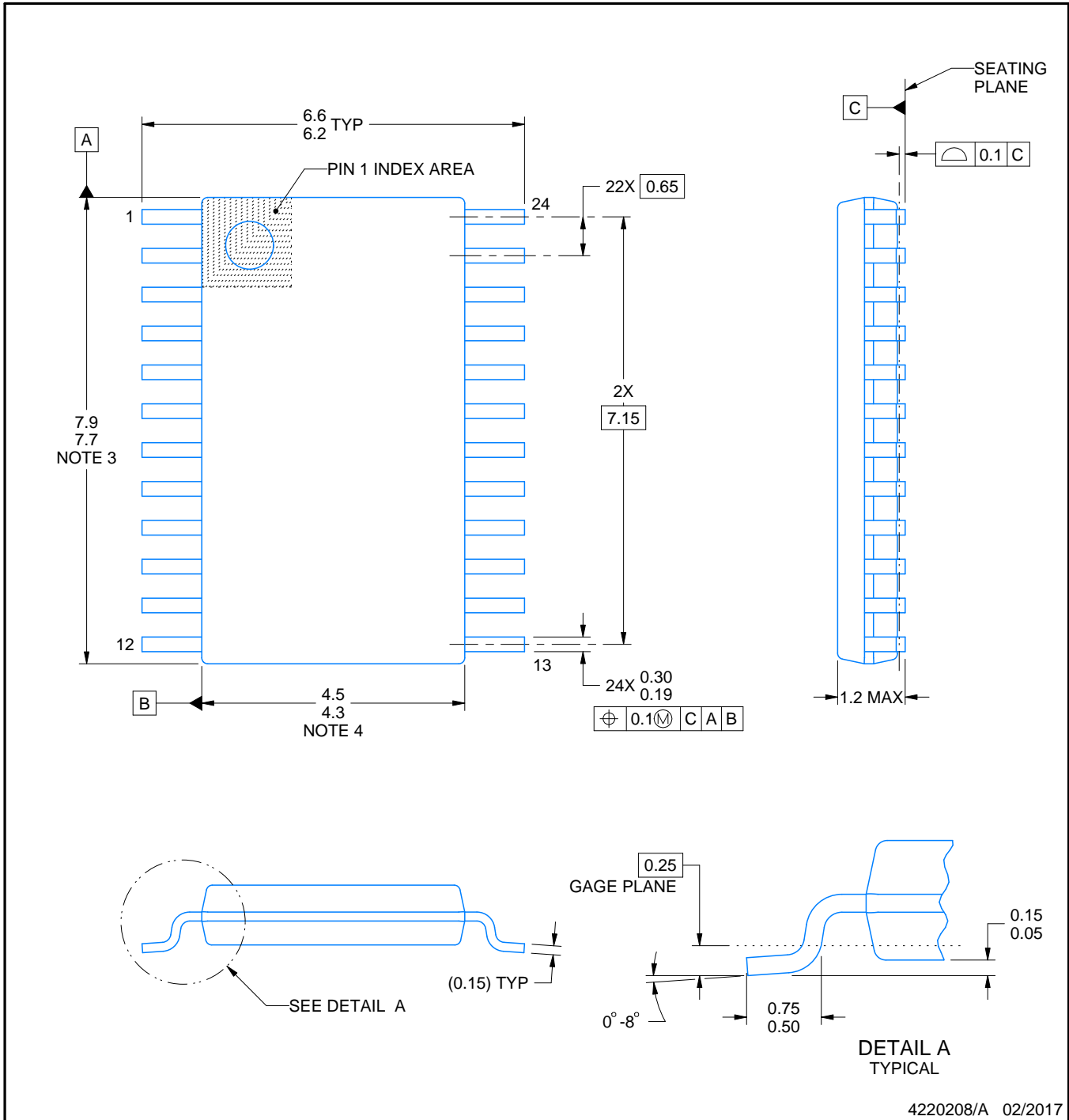

4220208/A 02/2017

### NOTES:

1. All linear dimensions are in millimeters. Any dimensions in parenthesis are for reference only. Dimensioning and tolerancing per ASME Y14.5M.
2. This drawing is subject to change without notice.
3. This dimension does not include mold flash, protrusions, or gate burrs. Mold flash, protrusions, or gate burrs shall not exceed 0.15 mm per side.
4. This dimension does not include interlead flash. Interlead flash shall not exceed 0.25 mm per side.
5. Reference JEDEC registration MO-153.

# EXAMPLE BOARD LAYOUT

PW0024A

TSSOP - 1.2 mm max height

SMALL OUTLINE PACKAGE

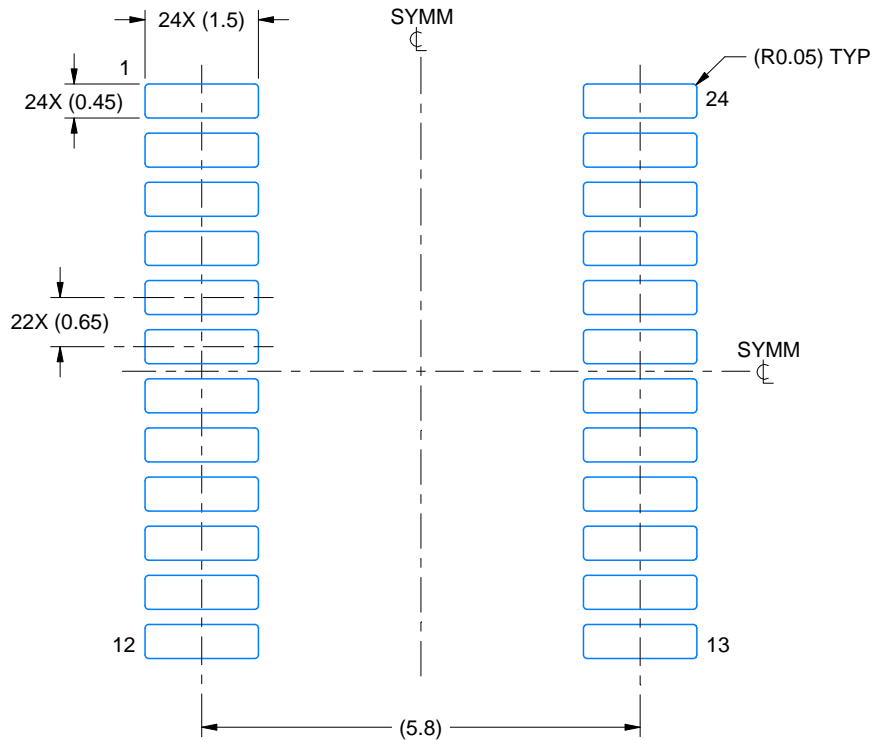

LAND PATTERN EXAMPLE  
EXPOSED METAL SHOWN  
SCALE: 10X

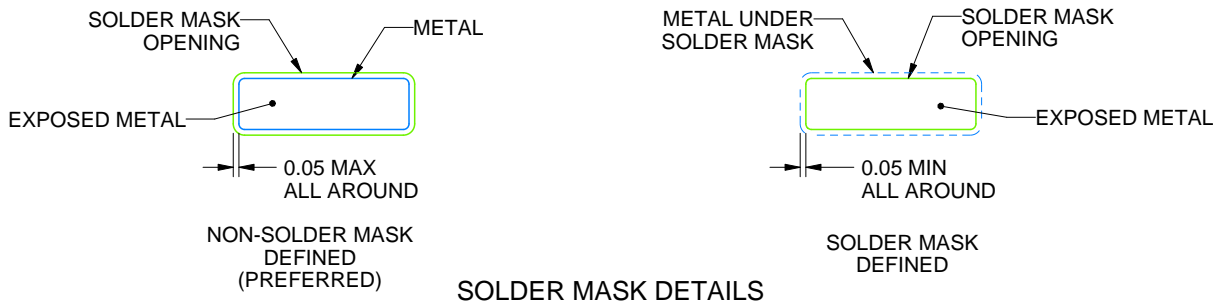

SOLDER MASK DETAILS

4220208/A 02/2017

NOTES: (continued)

- 6. Publication IPC-7351 may have alternate designs.
- 7. Solder mask tolerances between and around signal pads can vary based on board fabrication site.

# EXAMPLE STENCIL DESIGN

PW0024A

TSSOP - 1.2 mm max height

SMALL OUTLINE PACKAGE

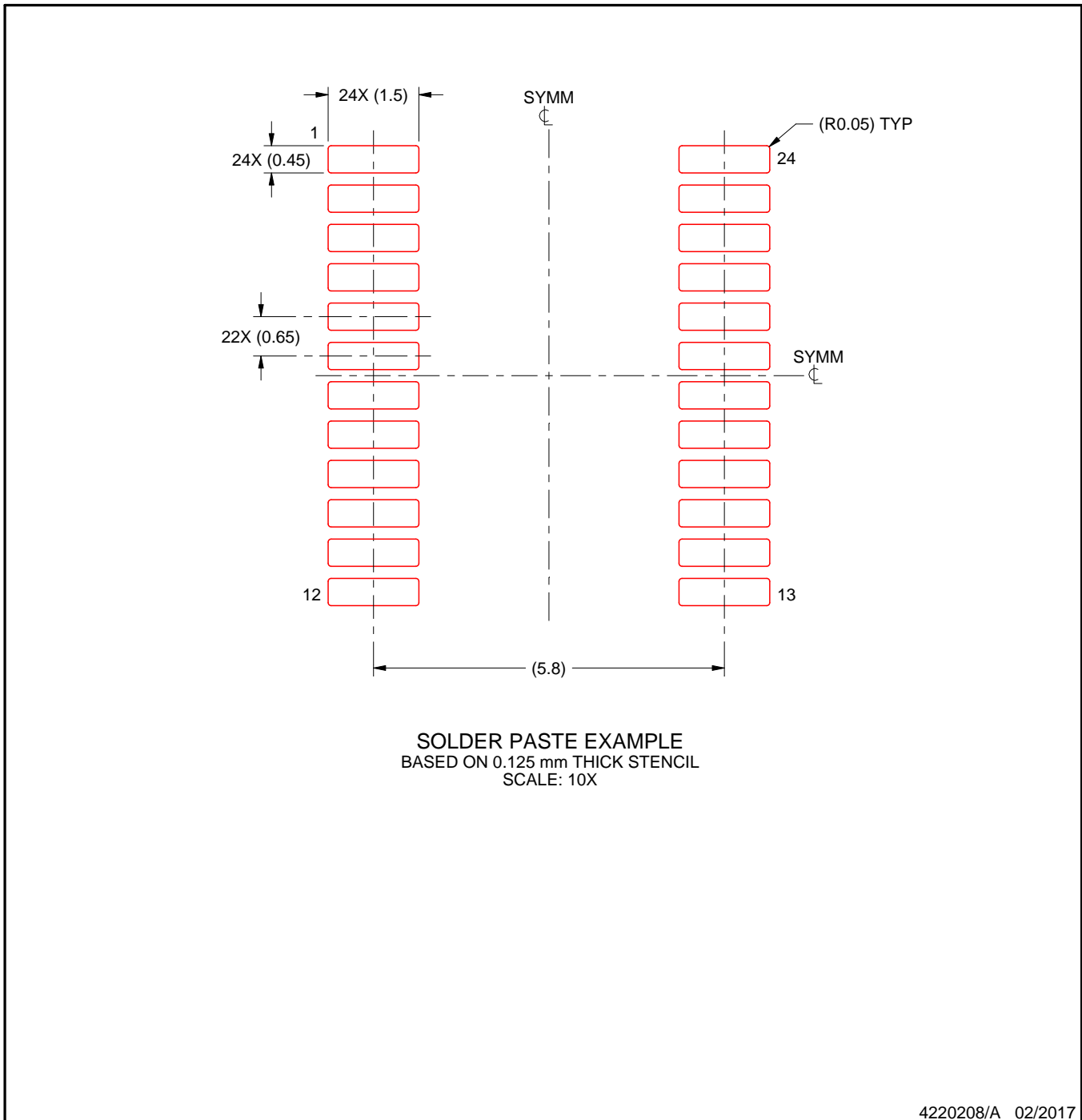

NOTES: (continued)

8. Laser cutting apertures with trapezoidal walls and rounded corners may offer better paste release. IPC-7525 may have alternate design recommendations.
9. Board assembly site may have different recommendations for stencil design.

## IMPORTANT NOTICE AND DISCLAIMER

TI PROVIDES TECHNICAL AND RELIABILITY DATA (INCLUDING DATA SHEETS), DESIGN RESOURCES (INCLUDING REFERENCE DESIGNS), APPLICATION OR OTHER DESIGN ADVICE, WEB TOOLS, SAFETY INFORMATION, AND OTHER RESOURCES "AS IS" AND WITH ALL FAULTS, AND DISCLAIMS ALL WARRANTIES, EXPRESS AND IMPLIED, INCLUDING WITHOUT LIMITATION ANY IMPLIED WARRANTIES OF MERCHANTABILITY, FITNESS FOR A PARTICULAR PURPOSE OR NON-INFRINGEMENT OF THIRD PARTY INTELLECTUAL PROPERTY RIGHTS.

These resources are intended for skilled developers designing with TI products. You are solely responsible for (1) selecting the appropriate TI products for your application, (2) designing, validating and testing your application, and (3) ensuring your application meets applicable standards, and any other safety, security, regulatory or other requirements.

These resources are subject to change without notice. TI grants you permission to use these resources only for development of an application that uses the TI products described in the resource. Other reproduction and display of these resources is prohibited. No license is granted to any other TI intellectual property right or to any third party intellectual property right. TI disclaims responsibility for, and you will fully indemnify TI and its representatives against, any claims, damages, costs, losses, and liabilities arising out of your use of these resources.

TI's products are provided subject to [TI's Terms of Sale](#) or other applicable terms available either on [ti.com](https://www.ti.com) or provided in conjunction with such TI products. TI's provision of these resources does not expand or otherwise alter TI's applicable warranties or warranty disclaimers for TI products.

TI objects to and rejects any additional or different terms you may have proposed.

Mailing Address: Texas Instruments, Post Office Box 655303, Dallas, Texas 75265  
Copyright © 2023, Texas Instruments Incorporated

## Looking for pricing, stock, or lifecycle information?

Click below to explore more details on WIN SOURCE:

 [View PCM1789PWR](#) on WIN SOURCE

 [Texas Instruments](#) Information

## Optimize Your Supply Chain with WIN SOURCE Solutions

-  Global Sourcing Solution
-  Obsolete Management
-  Cost Control Management
-  Shortage Management
-  Alternative Solution
-  Excess Inventory Management