



THE DATASHEET OF PCM1738E





24-Bit, 192-kHz Sampling, Advanced Segment, Audio-Stereo Digital-to-Analog Converter

FEATURES

- 24-Bit Resolution
- Analog Performance ($V_{CC} = 5\text{ V}$):
 - Dynamic Range: 117 dB (typical)
 - SNR: 117 dB (typical)
 - THD+N: 0.0004% (typical)
 - Full-Scale Output: 2.2 V_{rms} (at Postamplifier)
- Differential Current Output: $\pm 2.48\text{ mA}$
- Sampling Frequency: 10 kHz to 200 kHz
- System Clock: 128, 192, 256, 384, 512, or 768 f_s With Autodetect
- Accepts 16-, 20-, and 24-Bit Audio Data
- Data Formats: Standard, I²S, and Left-Justified
- 8× Oversampling Digital Filter:
 - Stop-Band Attenuation: –82 dB
 - Pass-Band Ripple: $\pm 0.002\text{ dB}$
- Optional Interface to External Digital Filter Available
- Optional Interface to DSD Decoder for SACD Playback
- User-Programmable Mode Controls:
 - Digital Attenuation: 0 dB to –120 dB, 0.5 dB/Step
 - Digital De-Emphasis
 - Digital Filter Rolloff: Sharp or Slow
 - Soft Mute
 - Zero-Detect Mute
 - Zero Flags for Each Output
- Dual-Supply Operation:
 - 5-V Analog, 3.3-V Digital
- 5-V Tolerant Digital Inputs
- Small SSOP-28 Package

APPLICATIONS

- AV Receivers
- DVD Movie Players
- SACD Players
- HDTV Receivers
- Car Audio Systems
- Digital Multitrack Recorders
- Other Multichannel Audio Systems

DESCRIPTION

The PCM1738 is a CMOS, monolithic, integrated circuit (IC) that includes stereo digital-to-analog converters (DACs) and support circuitry in a small SSOP-28 package. The data converters use a newly developed advanced segment DAC architecture to achieve excellent dynamic performance and improved tolerance to clock jitter. The PCM1738 provides balanced current outputs, allowing the user to optimize analog performance externally, and accepts industry-standard audio data formats with 16- to 24-bit data, providing easy interfacing to audio DSP and decoder chips. Sampling rates up to 200 kHz are supported. The PCM1738 also has two optional modes of operation: an external digital filter mode (for use with the DF1704, DF1706, and PMD200), and a DSD decoder interface for SACD playback applications. A full set of user-programmable functions is accessible through a 4-wire serial control port that supports register write and read functions.



Please be aware that an important notice concerning availability, standard warranty, and use in critical applications of Texas Instruments semiconductor products and disclaimers thereto appears at the end of this data sheet.

Audio Precision, System Two are trademarks of Audio Precision, Inc.
All other trademarks are the property of their respective owners.



This integrated circuit can be damaged by ESD. Texas Instruments recommends that all integrated circuits be handled with appropriate precautions. Failure to observe proper handling and installation procedures can cause damage.

ESD damage can range from subtle performance degradation to complete device failure. Precision integrated circuits may be more susceptible to damage because very small parametric changes could cause the device not to meet its published specifications.

ABSOLUTE MAXIMUM RATINGS

over operating free-air temperature range (unless otherwise noted)⁽¹⁾

| | | VALUE | UNIT |
|--|---------------------------------------|--------------------------------|---------|
| Power supply voltage | V_{CC1} , V_{CC2} , and V_{CC3} | 6.5 | V |
| | V_{DD} | 4 | V |
| Supply voltage differences among V_{CC1} , V_{CC2} , and V_{CC3} | | ± 0.1 | V |
| Supply voltage differences, V_{CCX} , V_{DD} | | $V_{CCX} - V_{DD} < 3$ | V |
| Ground voltage differences among AGND1, AGND2, and DGND | | ± 0.1 | V |
| Digital input voltage, LRCK, DATA, BCK, SCKI, MDI, MC, \overline{CS} , MUTE, and \overline{RST} | | -0.3 to 6.5 | V |
| Digital input voltage, ZEROL, ZEROR, SCKO, and MDO | | -0.3 to $(V_{DD} + 0.3) < 4$ | V |
| Analog input voltage, I_{OUTR-} , I_{OUTR+} , V_{COM1} , V_{COM2} , V_{COM3} , I_{REF} , I_{OUTL+} , and I_{OUTL-} | | -0.3 to $(V_{CC} + 0.3) < 6.5$ | V |
| Input current (except power supply) | | ± 10 | mA |
| Ambient temperature under bias | | -40 to 125 | °C |
| Storage temperature | | -55 to 150 | °C |
| Junction temperature | | 150 | °C |
| Lead temperature (soldering) | | 260 | °C, 5 s |
| Package temperature (reflow, peak) | | 235 | °C |

(1) Stresses beyond those listed under "absolute maximum ratings" may cause permanent damage to the device. These are stress ratings only, and functional operation of the device at these or any other conditions beyond those indicated under "recommended operating conditions" is not implied. Exposure to absolute-maximum-rated conditions for extended periods may affect device reliability.

ELECTRICAL CHARACTERISTICS

All specifications at $T_A = 25^\circ\text{C}$, $V_{DD} = 3.3\text{ V}$, $V_{CC} = 5\text{ V}$, $SCKI = 256 f_s$ ($f_s = 44.1\text{ kHz}$), and 24-bit input data (unless otherwise noted)

| PARAMETER | TEST CONDITIONS | PCM1738E | | | UNIT |
|------------------------------|-----------------|------------------------------------|-----|-----|------|
| | | MIN | TYP | MAX | |
| RESOLUTION | | 24 | | | Bits |
| DATA FORMAT | | | | | |
| Audio data interface formats | | Standard, I^2S , left-justified | | | |
| Audio data bit length | | 16-, 20-, 24-bit, selectable | | | |
| Audio data format | | MSB-first, 2s-complement | | | |
| Sampling frequency (f_s) | | 10 | | 200 | kHz |
| System clock frequency | | 128, 192, 256, 384, 512, 768 f_s | | | |

ELECTRICAL CHARACTERISTICS (continued)

 All specifications at $T_A = 25^\circ\text{C}$, $V_{DD} = 3.3\text{ V}$, $V_{CC} = 5\text{ V}$, $\text{SCKI} = 256 f_S$ ($f_S = 44.1\text{ kHz}$), and 24-bit input data (unless otherwise noted)

| PARAMETER | | TEST CONDITIONS | PCM1738E | | | UNIT |
|--|--|---|----------------|---------|---------------|---------------|
| | | | MIN | TYP | MAX | |
| DIGITAL INPUT/OUTPUT | | | | | | |
| Logic family | | | TTL compatible | | | |
| V_{IH} | Input logic level | | 2 | | | VDC |
| V_{IL} | | | 0.8 | | | |
| I_{IH} | Input logic current | $V_{IN} = V_{DD}$ | 10 | | | μA |
| I_{IL} | | $V_{IN} = 0\text{ V}$ | -10 | | | |
| V_{OH} | Output logic level | $I_{OH} = -2\text{ mA}$ | 2.4 | | | VDC |
| V_{OL} | | $I_{OL} = 2\text{ mA}$ | 1 | | | |
| I_{OHZ} | High-impedance output logic current ⁽¹⁾ | $V_{OUT} = V_{DD}$ | 5 | | | μA |
| I_{OLZ} | | | 5 | | | |
| DYNAMIC PERFORMANCE⁽²⁾ | | | | | | |
| THD+N | Total harmonic distortion + noise | $f_S = 44.1\text{ kHz}$, $V_{OUT} = 0\text{ dB}$ | 0.0004% | 0.0008% | | |
| | | $f_S = 96\text{ kHz}$, $V_{OUT} = 0\text{ dB}$ | 0.0006% | | | |
| | | $f_S = 192\text{ kHz}$, $V_{OUT} = 0\text{ dB}$ | 0.0012% | | | |
| Dynamic range | | EIAJ, A-weighted, $f_S = 44.1\text{ kHz}$ | 114 | 117 | | dB |
| | | A-weighted, $f_S = 96\text{ kHz}$ | 117 | | | |
| | | A-weighted, $f_S = 192\text{ kHz}$ | 117 | | | |
| SNR | Signal-to-noise ratio | EIAJ, A-weighted, $f_S = 44.1\text{ kHz}$ | 114 | 117 | | dB |
| | | A-weighted, $f_S = 96\text{ kHz}$ | 117 | | | |
| | | A-weighted, $f_S = 192\text{ kHz}$ | 117 | | | |
| Channel separation | | $f_S = 44.1\text{ kHz}$ | 110 | 115 | | dB |
| | | $f_S = 96\text{ kHz}$ | 113 | | | |
| | | $f_S = 192\text{ kHz}$ | 111 | | | |
| Level linearity error | | $V_{OUT} = -110\text{ dB}$ | ± 1 | | dB | |
| DC ACCURACY | | | | | | |
| V_{CCM2} voltage | | | 2.45 | | V | |
| V_{CCM2} output current | | $\Delta V_{COM2} < 5\%$ | 100 | | μA | |
| Gain error | | | ± 2 | | % of FSR | |
| Gain mismatch, channel-to-channel | | | ± 0.5 | | % of FSR | |
| Bipolar zero error | | At bipolar zero | ± 0.5 | | % of FSR | |
| DSD-MODE DYNAMIC PERFORMANCE at 44.1 kHz, 64 f_S⁽³⁾ | | | | | | |
| THD+N | Total harmonic distortion + noise | $\pm 2.48\text{ mAp-p}$, full scale | 0.0004% | | | |
| Dynamic range | | -60 dB, EIAJ, A-weighted | 117 | | dB | |
| SNR | Signal-to-noise ratio | EIAJ, A-weighted | 117 | | dB | |
| ANALOG OUTPUT | | | | | | |
| Output current | | Full scale (0 dB) | ± 2.48 | | mAp-p | |
| DSD mode output current | | 50% output | ± 1.24 | | mAp-p | |
| Center current | | Bipolar zero input | 0 | | mA | |

(1) Pin 11 (MDO)

(2) Analog performance specifications are measured using an Audio Precision™ System Two™ audio measurement system in the averaging mode. At 44.1-kHz operation, bandwidth measurement is limited to 20 kHz. At 96 kHz and 192 kHz, bandwidth measurement is limited to 40 kHz.

(3) Theoretical performance in DSD modulation index of 100%. Performance is equivalent to the PCM mode.

ELECTRICAL CHARACTERISTICS (continued)

All specifications at $T_A = 25^\circ\text{C}$, $V_{DD} = 3.3\text{ V}$, $V_{CC} = 5\text{ V}$, $\text{SCKI} = 256 f_S$ ($f_S = 44.1\text{ kHz}$), and 24-bit input data (unless otherwise noted)

| PARAMETER | TEST CONDITIONS | PCM1738E | | | UNIT | |
|--|-------------------------|---|------|-------------|--------------------|-----|
| | | MIN | TYP | MAX | | |
| DIGITAL-FILTER PERFORMANCE | | | | | | |
| Filter Characteristics 1, Sharp Rolloff | | | | | | |
| Pass band | $\pm 0.002\text{ dB}$ | | | $0.454 f_S$ | Hz | |
| Pass band | -3 dB | | | $0.49 f_S$ | Hz | |
| Stop band | | $0.546 f_S$ | | | Hz | |
| Pass-band ripple | | | | ± 0.002 | dB | |
| Stop-band attenuation | Stop band = $0.546 f_S$ | -75 | | | dB | |
| Stop-band attenuation | Stop band = $0.567 f_S$ | -82 | | | dB | |
| Filter Characteristics 2, Slow Rolloff | | | | | | |
| Pass band | $\pm 0.04\text{ dB}$ | | | $0.274 f_S$ | Hz | |
| Pass band | -3 dB | | | $0.454 f_S$ | Hz | |
| Stop band | | $0.732 f_S$ | | | Hz | |
| Pass-band ripple | | | | ± 0.002 | dB | |
| Stop-band attenuation | Stop band = $0.732 f_S$ | -82 | | | dB | |
| Delay time | | | | $29/f_S$ | sec | |
| De-emphasis error | | | | ± 0.1 | dB | |
| POWER SUPPLY REQUIREMENTS | | | | | | |
| V_{DD} | Voltage range | | 3 | 3.3 | 3.6 | VDC |
| V_{CC} | | | 4.75 | 5 | 5.25 | |
| $I_{DD}^{(4)}$ | Supply current | $V_{DD} = 3.3\text{ V}, f_S = 44.1\text{ kHz}$ | | 7 | 9.8 | mA |
| | | $V_{DD} = 3.3\text{ V}, f_S = 96\text{ kHz}$ | | 15 | | |
| | | $V_{DD} = 3.3\text{ V}, f_S = 192\text{ kHz}$ | | 30 | | |
| I_{CC} | Supply current | $V_{CC} = 5\text{ V}, f_S = 44.1\text{ kHz}$ | | 33 | 46.2 | mA |
| | | $V_{CC} = 5\text{ V}, f_S = 96\text{ kHz}$ | | 34.5 | | |
| | | $V_{CC} = 5\text{ V}, f_S = 192\text{ kHz}$ | | 36.5 | | |
| Power dissipation | | $V_{DD} = 3.3\text{ V}, V_{CC} = 5\text{ V}, f_S = 44.1\text{ kHz}$ | | 188 | 263 | mW |
| | | $V_{DD} = 3.3\text{ V}, V_{CC} = 5\text{ V}, f_S = 96\text{ kHz}$ | | 222 | | |
| | | $V_{DD} = 3.3\text{ V}, V_{CC} = 5\text{ V}, f_S = 192\text{ kHz}$ | | 282 | | |
| TEMPERATURE RANGE | | | | | | |
| Operation temperature | | -25 | | 85 | $^\circ\text{C}$ | |
| θ_{JA} | Thermal resistance | | | 100 | $^\circ\text{C/W}$ | |

(4) SCKO is disabled. Input is bipolar zero data.

BLOCK DIAGRAM

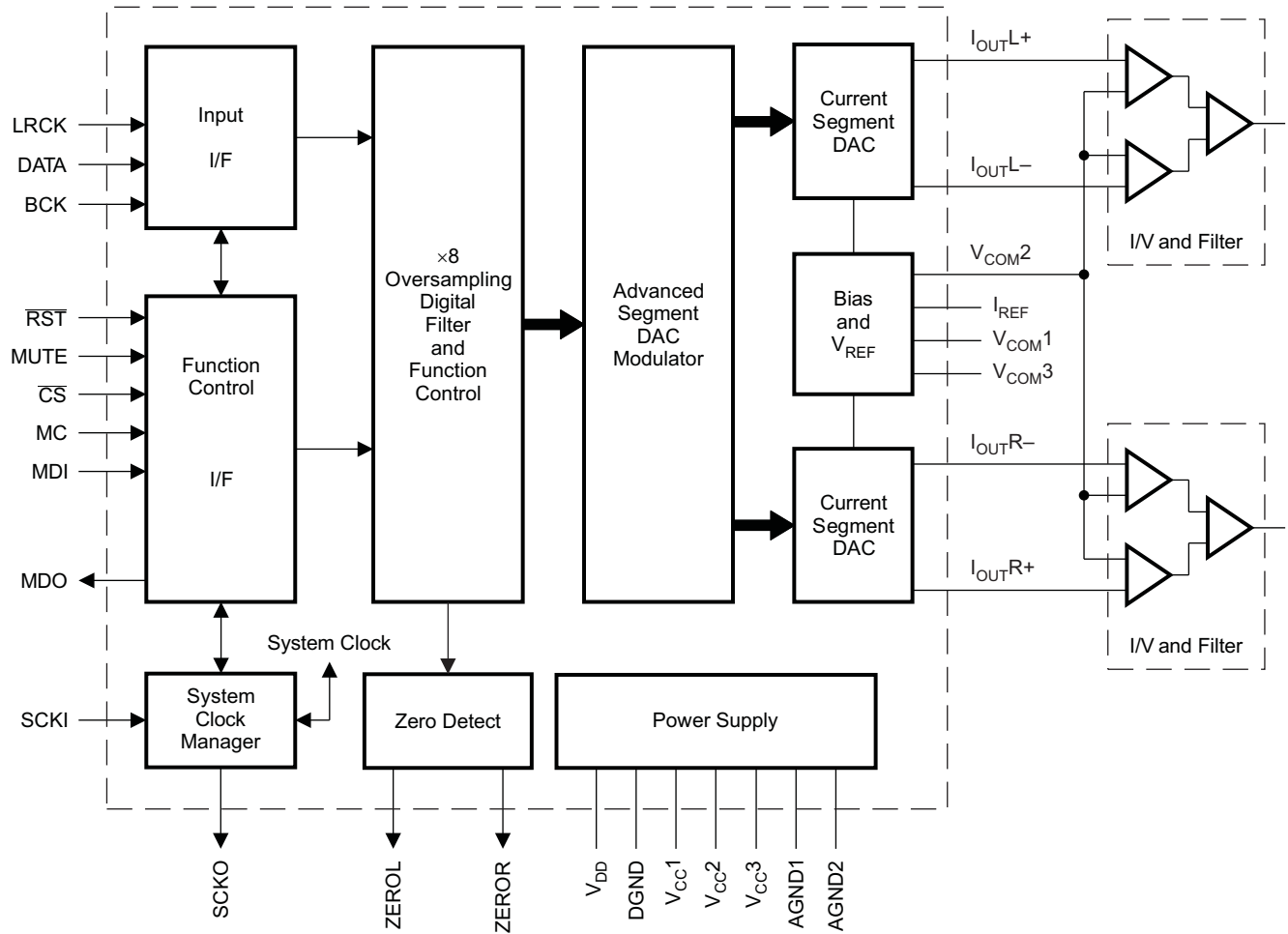

B0200-01

**PCM1738
(TOP VIEW)**

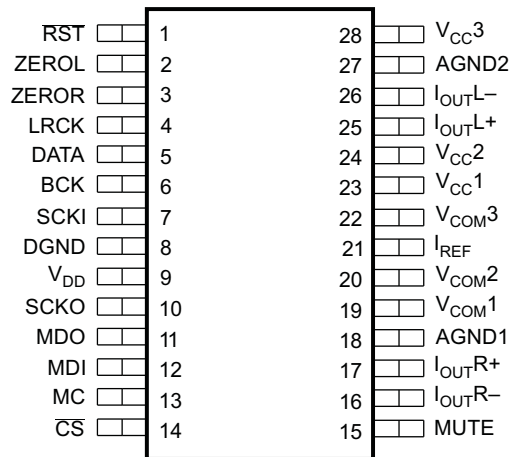

P0007-04

Table 1. TERMINAL FUNCTIONS

| TERMINAL | | TYPE | DESCRIPTION |
|--------------------|-----|------|--|
| NAME | NO. | | |
| AGND1 | 18 | — | Analog ground 1 |
| AGND2 | 27 | — | Analog ground 2 |
| \overline{CS} | 14 | IN | Chip select and latch for mode control ⁽¹⁾ |
| BCK | 6 | IN | Bit-clock input. Connected to GND for DSD mode ⁽¹⁾ |
| DATA | 5 | IN | Serial audio data input for normal operation. L-channel audio data input for external DF and DSD modes ⁽¹⁾ |
| DGND | 8 | — | Digital ground |
| I _{OUTL+} | 25 | OUT | L-channel analog current output + |
| I _{OUTL-} | 26 | OUT | L-channel analog current output – |
| I _{OUTR+} | 17 | OUT | R-channel analog current output + |
| I _{OUTR-} | 16 | OUT | R-channel analog current output – |
| I _{REF} | 21 | — | Output current reference bias pin. Connect 16-k Ω resistor to GND. |
| LRCK | 4 | IN | Left/right clock (f_S) input for normal operation. WDCK clock input in external DF mode. Connected to GND in DSD mode ⁽¹⁾ |
| MC | 13 | IN | Shift clock for mode control ⁽¹⁾ |
| MDI | 12 | IN | Serial data input for mode control ⁽¹⁾ |
| MDO | 11 | OUT | Serial data output for mode control |
| MUTE | 15 | IN | Analog output mute control for normal operation. R-channel audio data input for external DF and DSD modes ⁽¹⁾ |
| \overline{RST} | 1 | IN | Reset ⁽¹⁾ |
| SCKI | 7 | IN | System-clock input for normal operation. BCK (64 f_S) clock input for DSD mode ⁽¹⁾ |
| SCKO | 10 | OUT | System clock output |
| V _{CC1} | 23 | — | Analog power supply 1, 5-V |
| V _{CC2} | 24 | — | Analog power supply 2, 5-V |
| V _{CC3} | 28 | — | Analog power supply 3, 5-V |
| V _{COM1} | 19 | — | Internal bias decoupling 1 |
| V _{COM2} | 20 | — | Internal bias decoupling 2 (common voltage for I/V) |
| V _{COM3} | 22 | — | Internal bias decoupling 3 |
| V _{DD} | 9 | — | Digital supply, 3.3 V |
| ZEROL | 2 | OUT | Zero flag for L-channel |
| ZEROR | 3 | OUT | Zero flag for R-channel |

(1) Schmitt-trigger input, 5-V tolerant.

TYPICAL PERFORMANCE CURVES

All specifications at $T_A = 25^\circ\text{C}$, $V_{DD} = 3.3\text{ V}$, $V_{CC} = 5\text{ V}$, $\text{SCKI} = 256 f_s$ ($f_s = 44.1\text{ kHz}$), and 24-bit input data (unless otherwise noted).

DIGITAL FILTER

De-Emphasis Off, $f_s = 44.1\text{ kHz}$

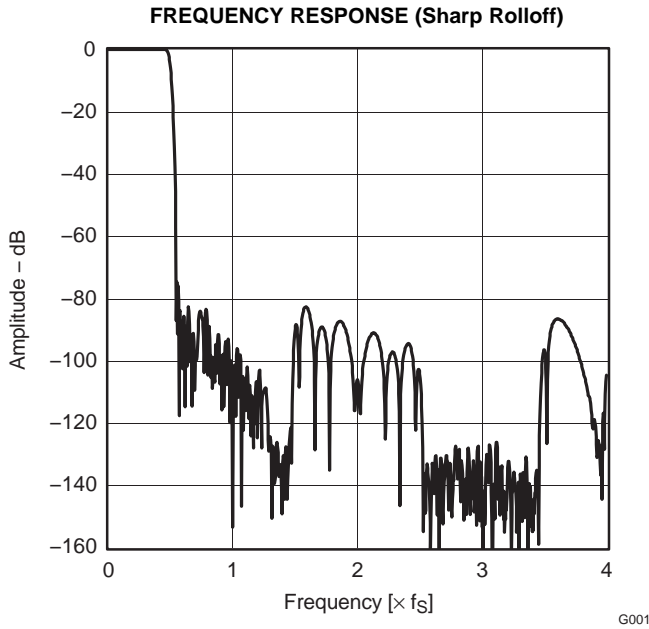

Figure 1.

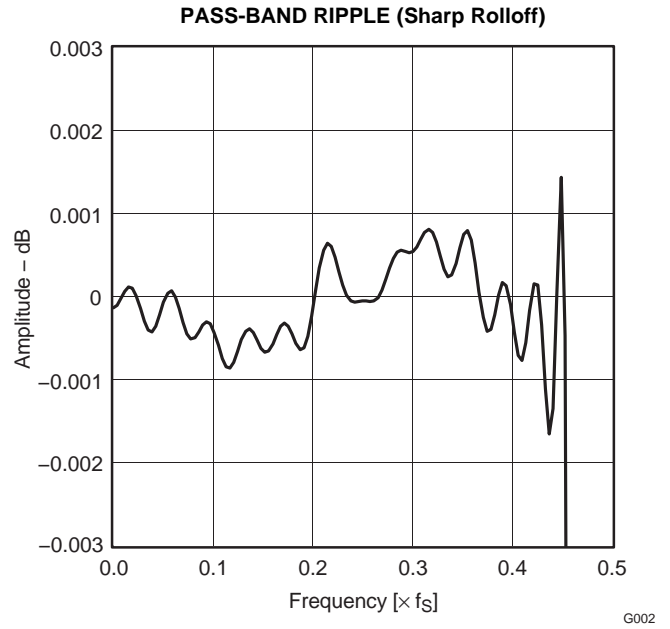

Figure 2.

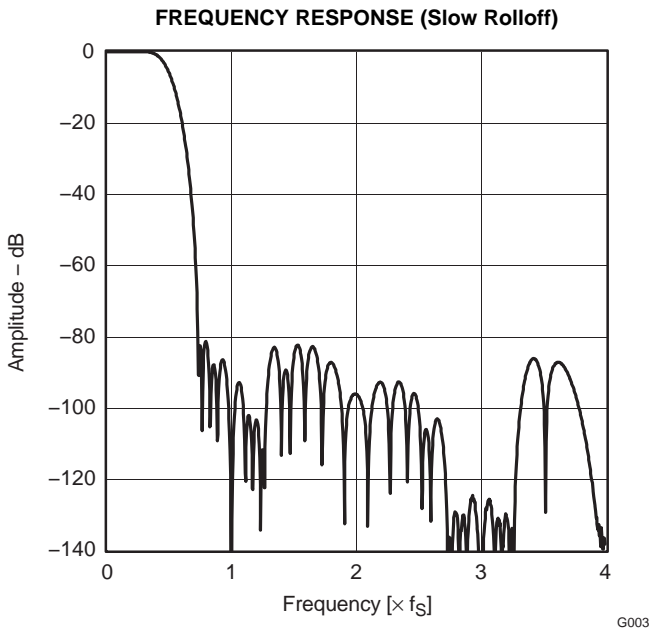

Figure 3.

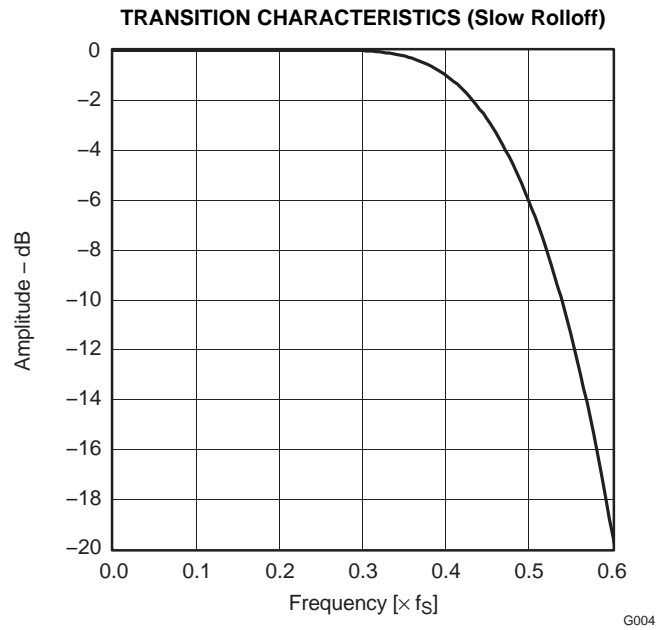

Figure 4.

TYPICAL CHARACTERISTICS (continued)

All specifications at $T_A = 25^\circ\text{C}$, $V_{DD} = 3.3\text{ V}$, $V_{CC} = 5\text{ V}$, $\text{SCKI} = 256 f_S$ ($f_S = 44.1\text{ kHz}$), and 24-bit input data (unless otherwise noted).

De-Emphasis Filter

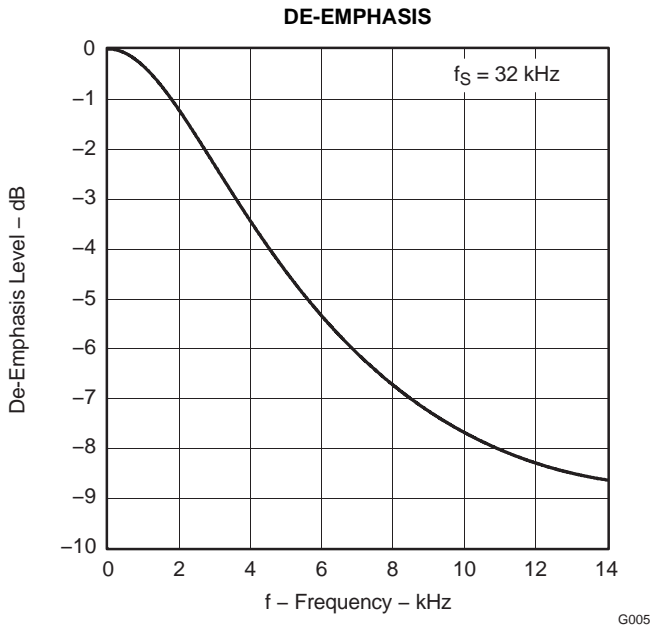

Figure 5.

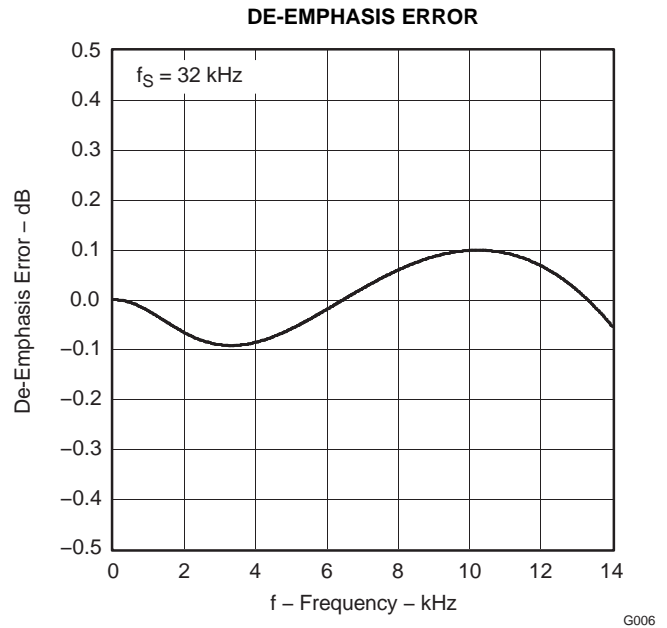

Figure 6.

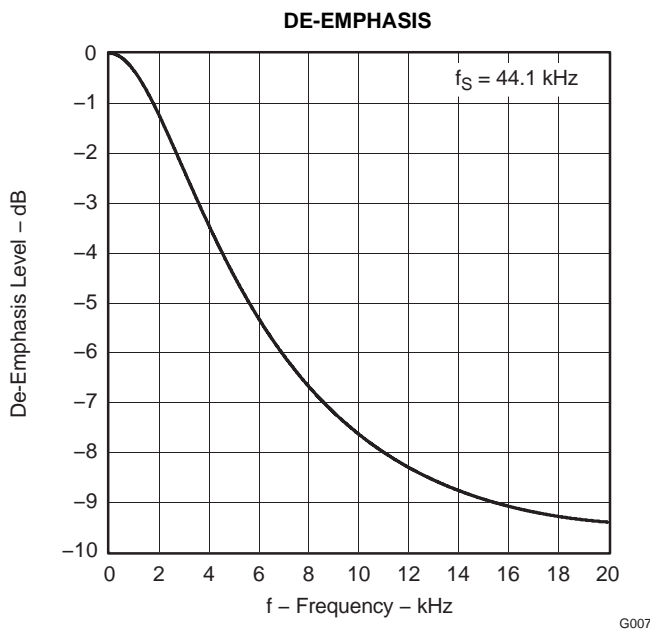

Figure 7.

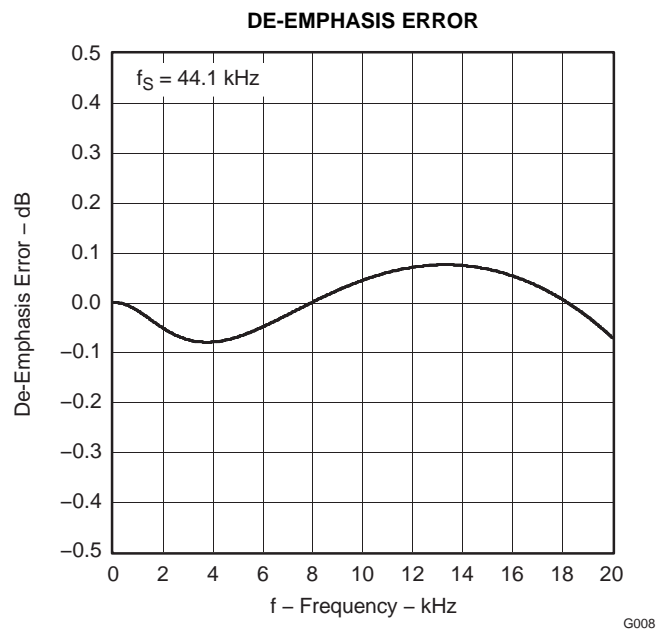

Figure 8.

TYPICAL CHARACTERISTICS (continued)

All specifications at $T_A = 25^\circ\text{C}$, $V_{DD} = 3.3\text{ V}$, $V_{CC} = 5\text{ V}$, $\text{SCKI} = 256 f_S$ ($f_S = 44.1\text{ kHz}$), and 24-bit input data (unless otherwise noted).

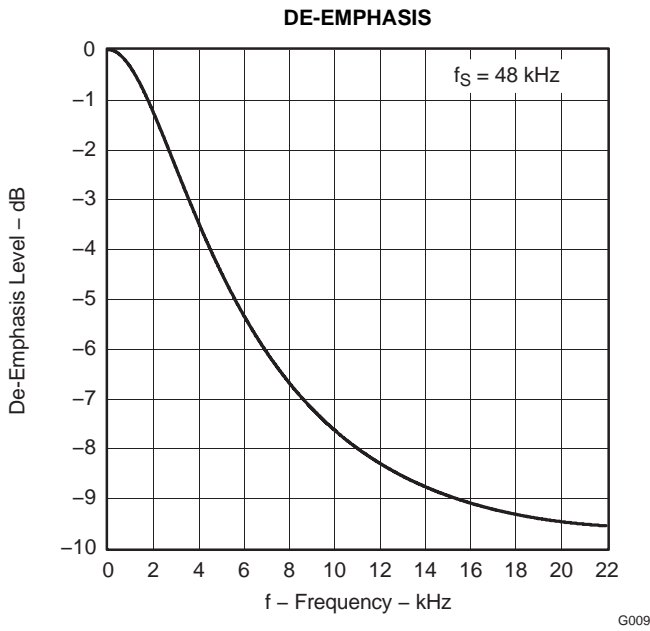

Figure 9.

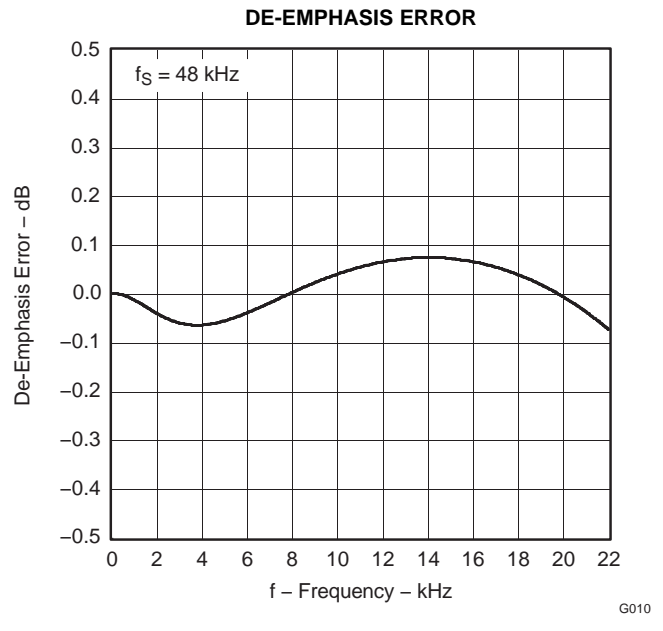

Figure 10.

ANALOG DYNAMIC PERFORMANCE

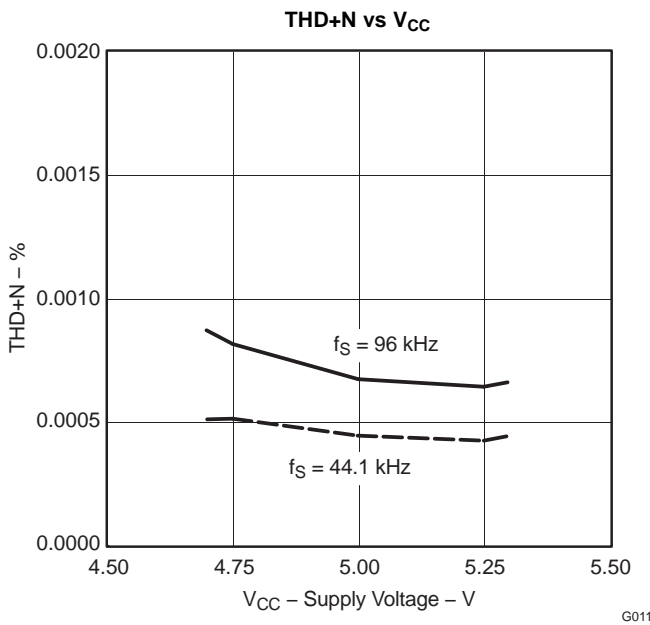

Figure 11.

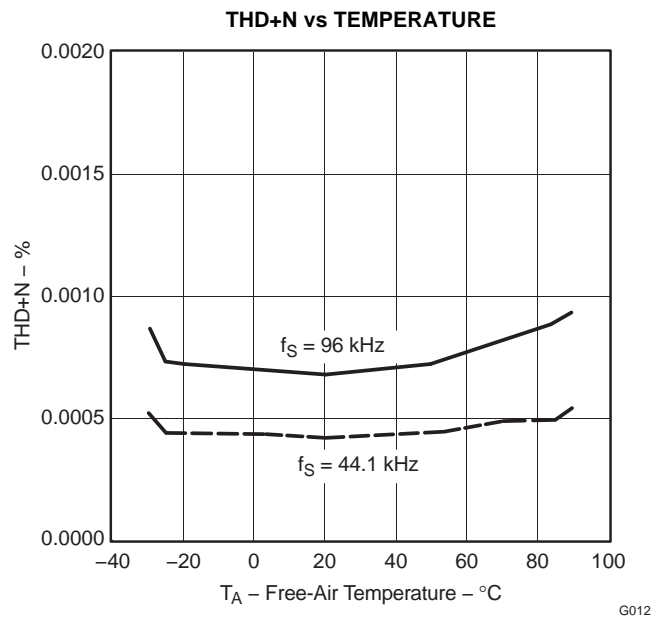

Figure 12.

TYPICAL CHARACTERISTICS (continued)

All specifications at $T_A = 25^\circ\text{C}$, $V_{DD} = 3.3\text{ V}$, $V_{CC} = 5\text{ V}$, $\text{SCKI} = 256 f_S$ ($f_S = 44.1\text{ kHz}$), and 24-bit input data (unless otherwise noted).

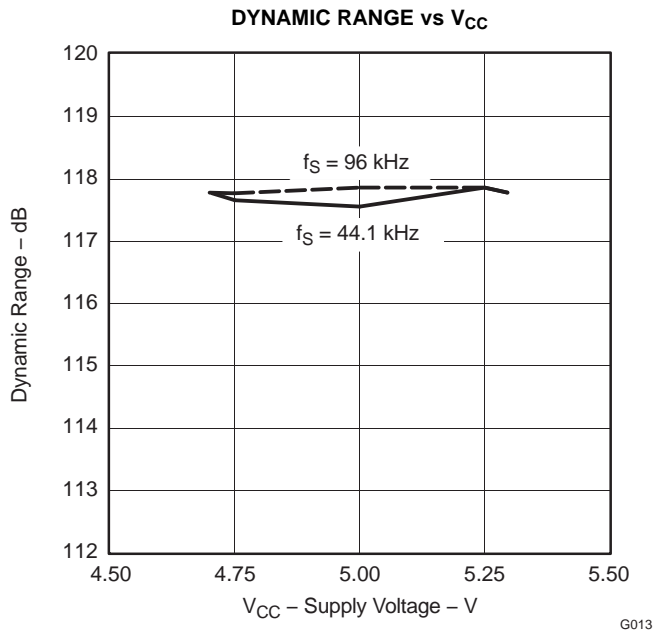

Figure 13.

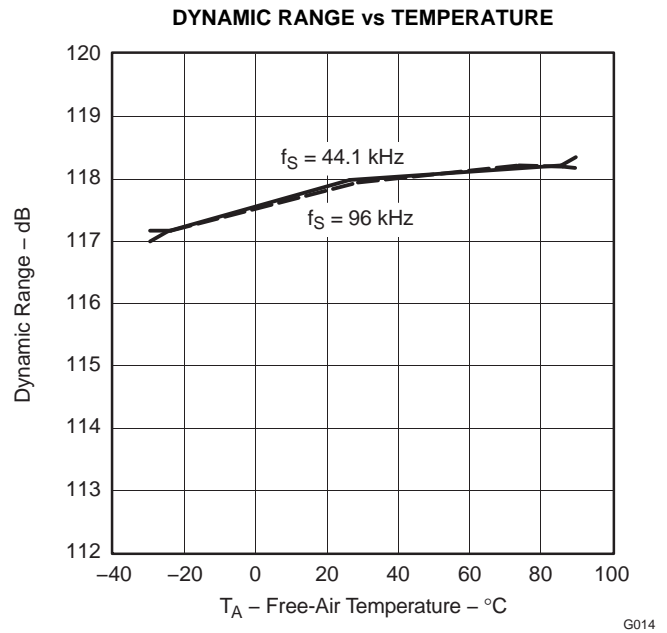

Figure 14.

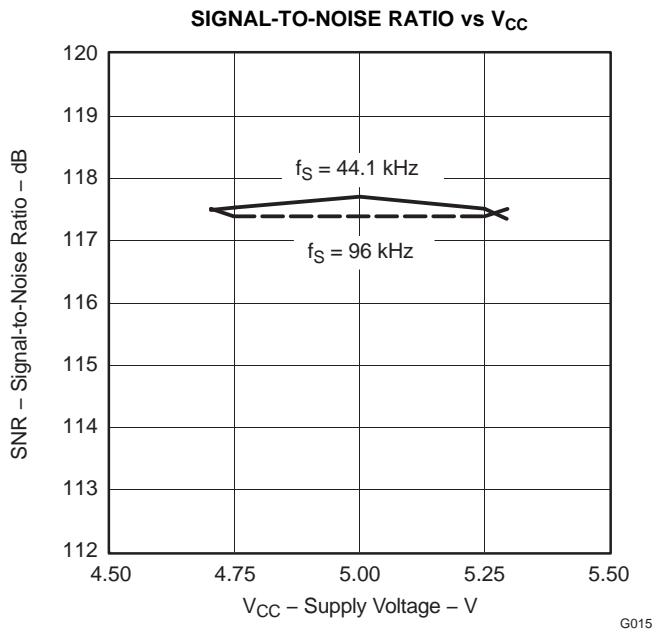

Figure 15.

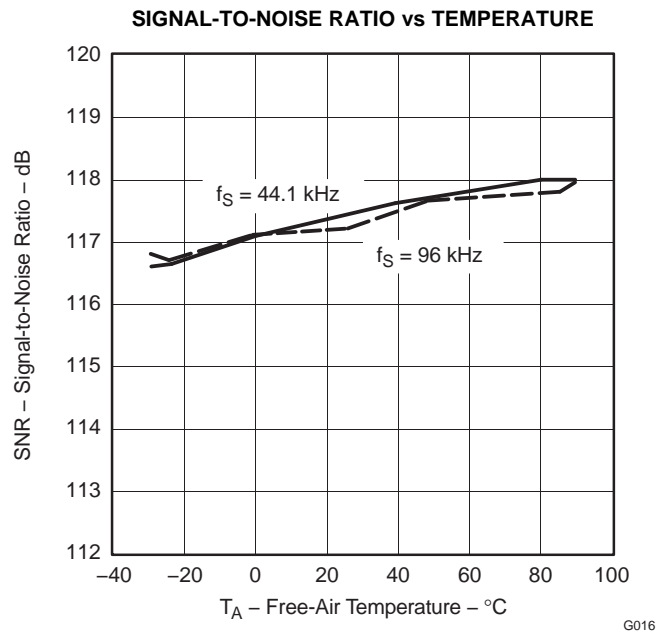

Figure 16.

TYPICAL CHARACTERISTICS (continued)

All specifications at $T_A = 25^\circ\text{C}$, $V_{DD} = 3.3\text{ V}$, $V_{CC} = 5\text{ V}$, $\text{SCKI} = 256 f_S$ ($f_S = 44.1\text{ kHz}$), and 24-bit input data (unless otherwise noted).

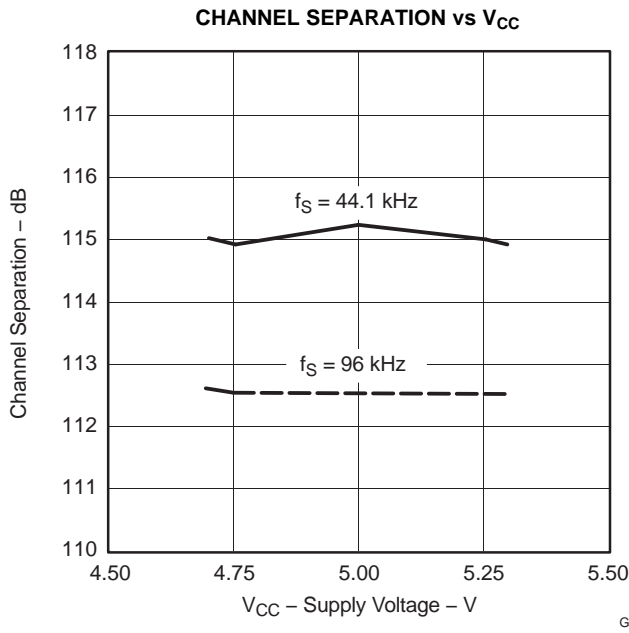

Figure 17.

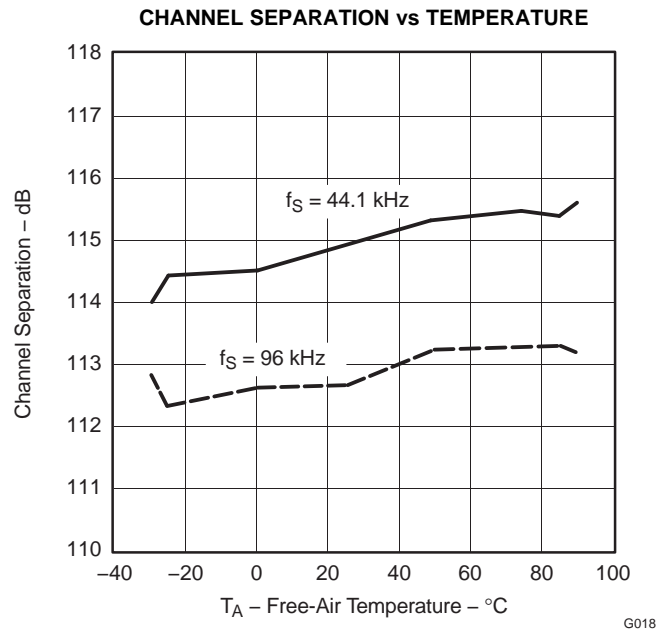

Figure 18.

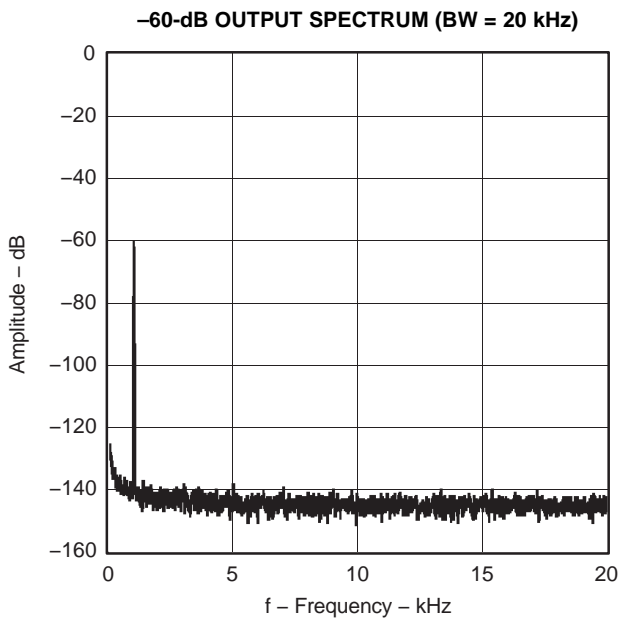

Figure 19.

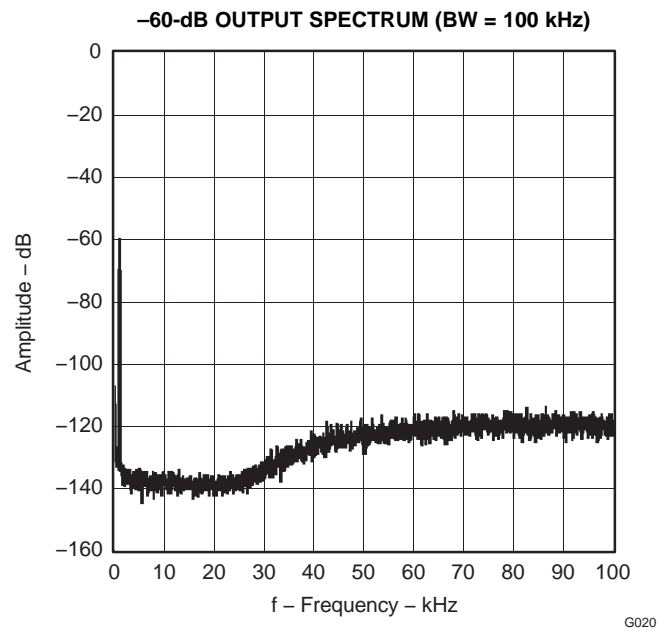

Figure 20.

TYPICAL CHARACTERISTICS (continued)

All specifications at $T_A = 25^\circ\text{C}$, $V_{DD} = 3.3\text{ V}$, $V_{CC} = 5\text{ V}$, $\text{SCKI} = 256 f_s$ ($f_s = 44.1\text{ kHz}$), and 24-bit input data (unless otherwise noted).

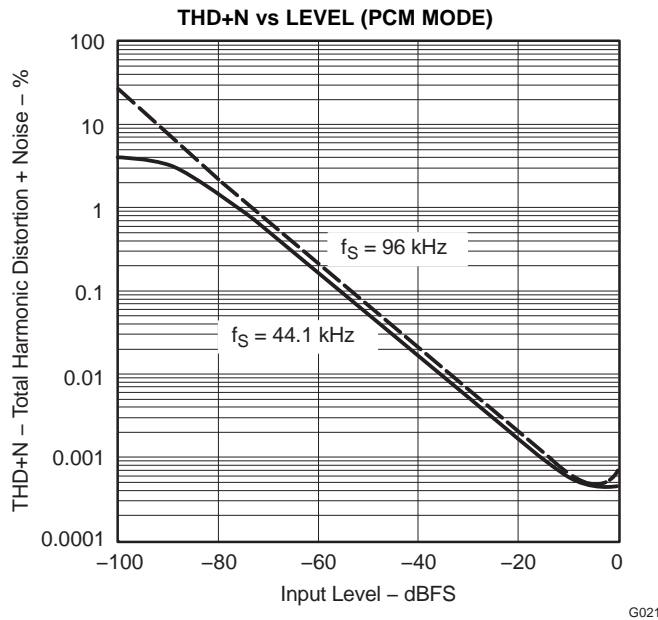

Figure 21.

All specifications at $T_A = 25^\circ\text{C}$, $V_{DD} = 3.3\text{ V}$, $V_{CC} = 5\text{ V}$, $\text{SCKI} = 64 f_s$ ($f_s = 44.1\text{ kHz}$), and DSD input data (44.1 kHz, $64 f_s$, DSD modulator index of 0.5) (unless otherwise noted)

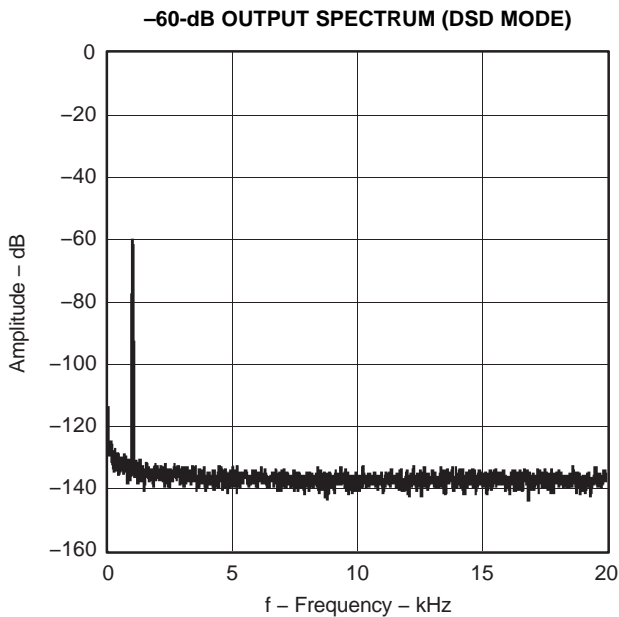

Figure 22.

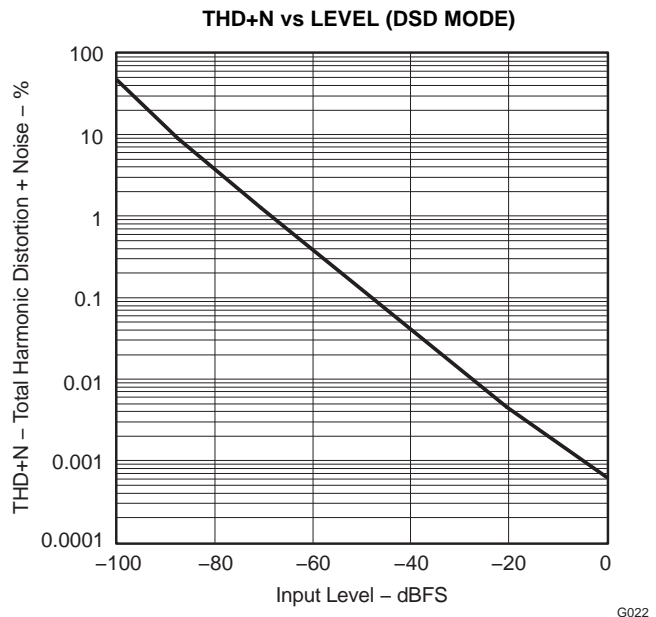

Figure 23.

ANALOG FIR FILTER PERFORMANCE FOR DSD MODE

All specifications at $T_A = 25^\circ\text{C}$, $V_{DD} = 3.3\text{ V}$, $V_{CC} = 5\text{ V}$, $\text{SCKI} = 11.2896\text{ MHz}$ ($44.1\text{ kHz} \times 256 f_s$), and 50% modulation DSD data input (unless otherwise noted)

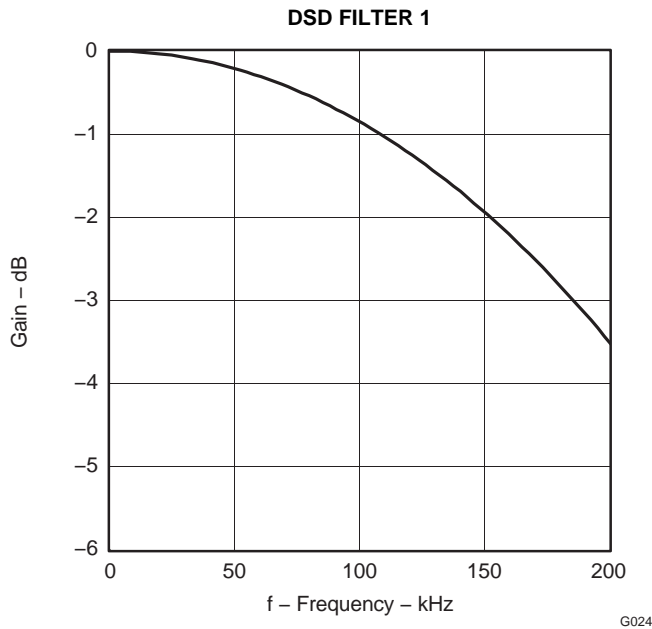

Figure 24.

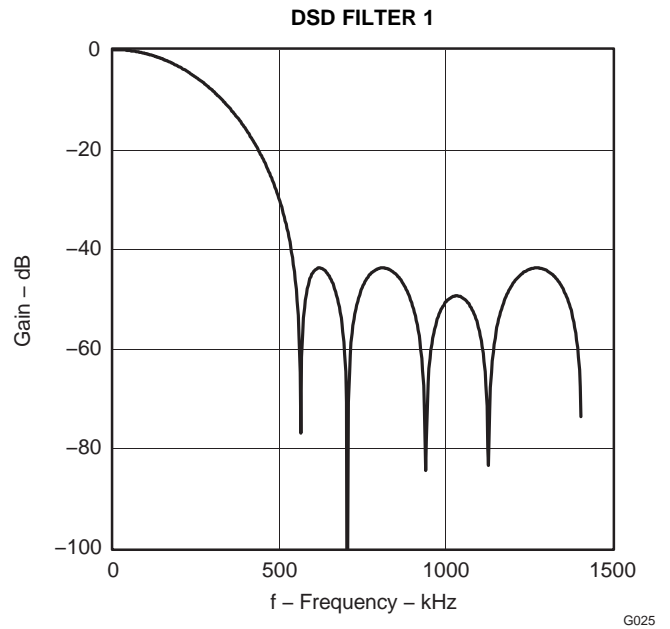

Figure 25.

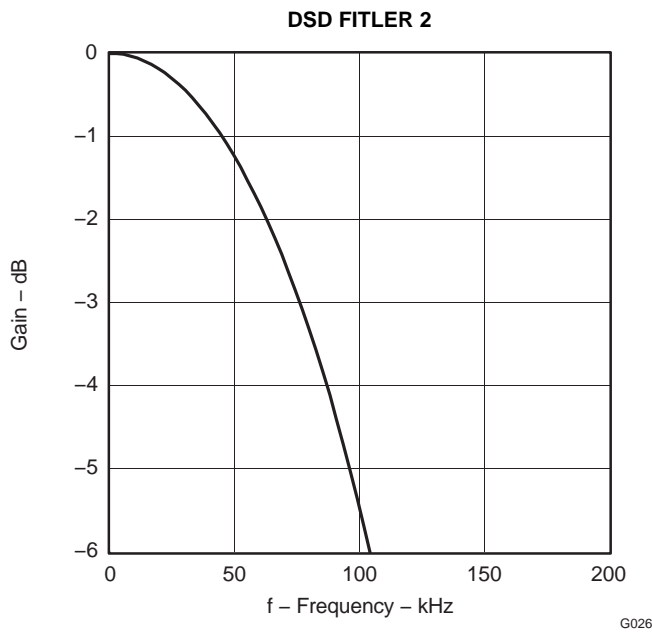

Figure 26.

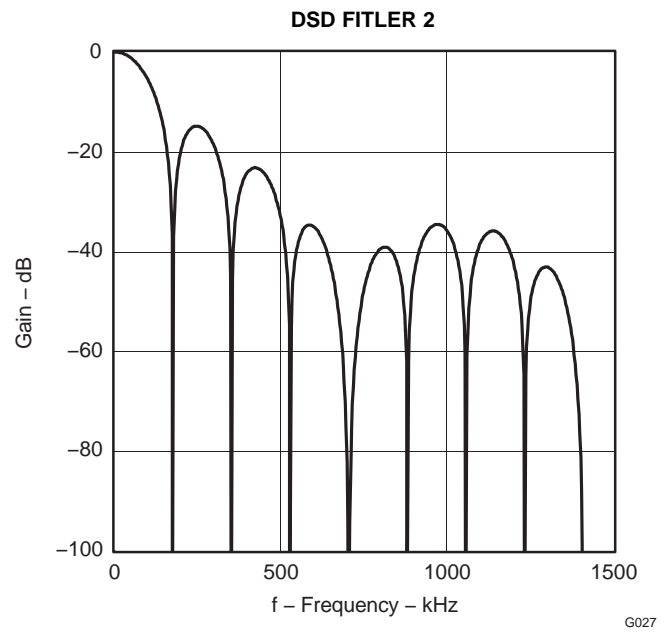

Figure 27.

ANALOG FIR FILTER PERFORMANCE FOR DSD MODE (continued)

All specifications at $T_A = 25^\circ\text{C}$, $V_{DD} = 3.3\text{ V}$, $V_{CC} = 5\text{ V}$, $\text{SCKI} = 11.2896\text{ MHz}$ ($44.1\text{ kHz} \times 256 f_s$), and 50% modulation DSD data input (unless otherwise noted)

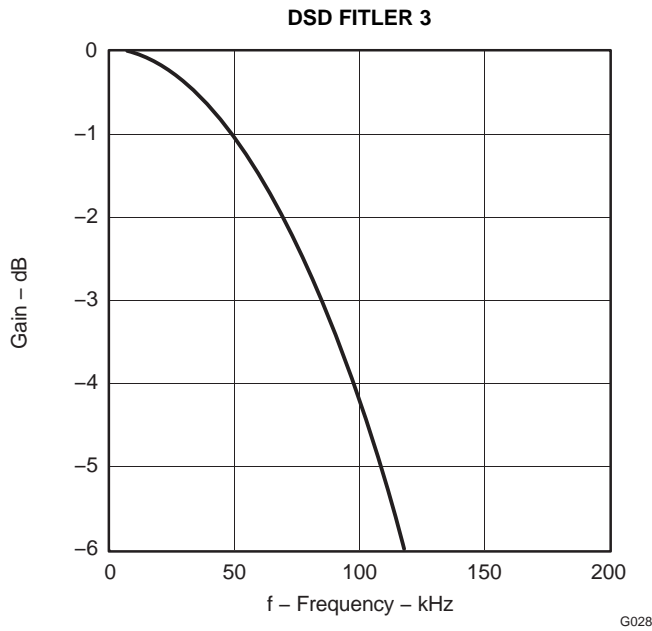

Figure 28.

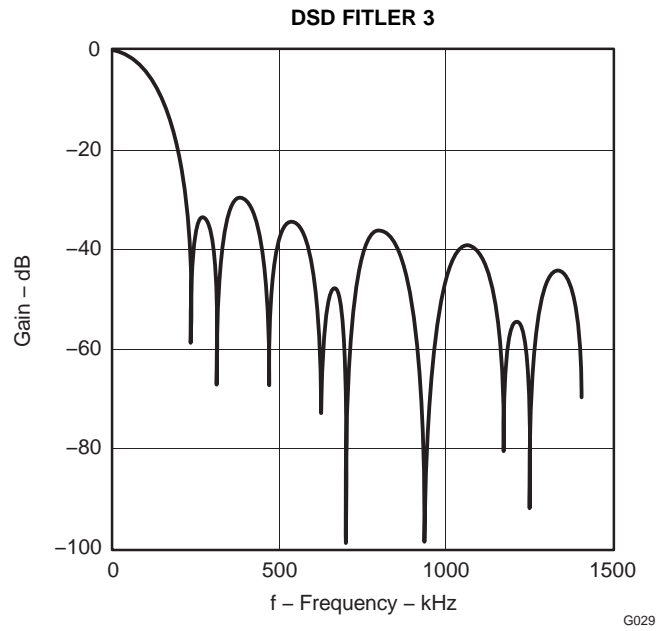

Figure 29.

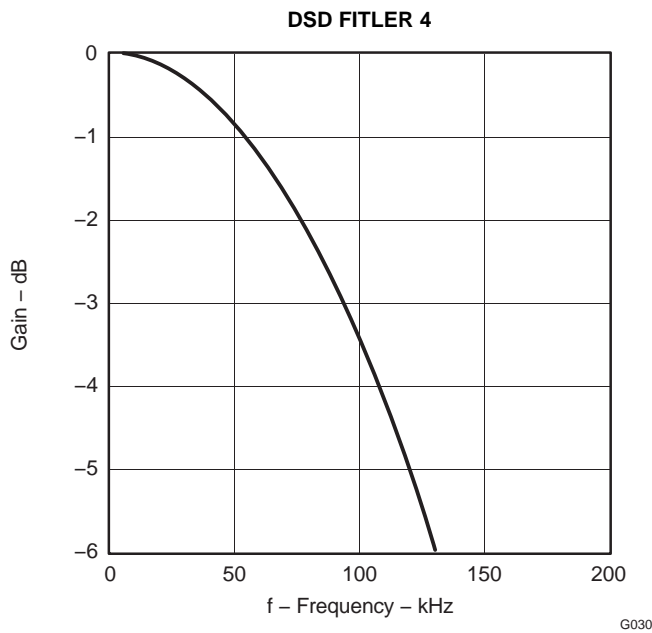

Figure 30.

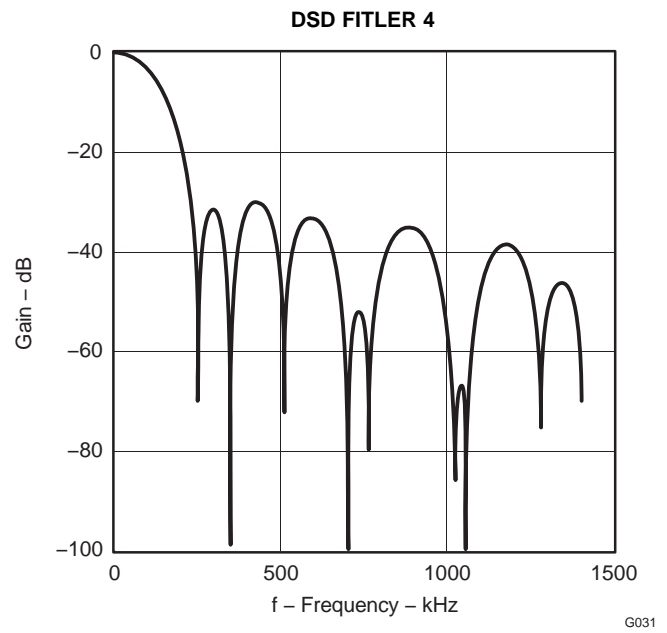

Figure 31.

SYSTEM CLOCK AND RESET FUNCTIONS

SYSTEM CLOCK INPUT

The PCM1738 requires a system clock for operating the digital interpolation filters and advanced segment DAC modulators. The system clock is applied at the SCKI input (pin 7). The PCM1738 has a system-clock detection circuit that automatically senses if the system clock is operating at $128 f_s$ to $768 f_s$. [Table 2](#) shows examples of system-clock frequencies for common audio sampling rates.

[Figure 32](#) shows the timing requirements for the system clock input. For optimal performance, it is important to use a clock source with low phase jitter and noise. The PLL1700 multiclock generator is an excellent choice for providing the PCM1738 system clock.

SYSTEM CLOCK OUTPUT

A buffered version of the system clock input is available at the SCKO output (pin 10). SCKO can operate at either full (f_{SCKI}) or half ($f_{SCKI}/2$) rate. The SCKO output frequency may be programmed using the CLKD bit of mode control register 19. The SCKO output pin can also be enabled or disabled using the CLKE bit of mode control register 19. The default is SCKO enabled.

POWER-ON AND EXTERNAL RESET FUNCTIONS

The PCM1738 includes a power-on-reset function (see [Figure 33](#)). The system clock input at SCKI should be active for at least one clock period prior to $V_{DD} = 2$ V. With the system clock active, and $V_{DD} > 2$ V, the power-on-reset function is enabled. The initialization sequence requires 1024 system clocks from the time $V_{DD} > 2$ V. After the initialization period, the PCM1738 is set to its reset default state, as described in the [Mode Control Registers](#) section of this data sheet.

The PCM1738 also includes an external reset capability using the \overline{RST} input (pin 1). This allows an external controller or master reset circuit to force the PCM1738 to initialize to its reset default state.

See [Figure 34](#) for external reset operation and timing. The \overline{RST} pin is set to a logic 0 for a minimum of 20 ns. The \overline{RST} pin is then set to a logic-1 state that starts the initialization sequence that requires 1024 system clock periods. After the initialization sequence is complete, the PCM1738 is set to its reset default state, as described in the [Mode Control Registers](#) section of this data sheet.

The external reset is especially useful in applications where there is a delay between PCM1738 power up and system-clock activation. In this case, the \overline{RST} pin should be held at a logic-0 level until the system clock has been activated. The \overline{RST} pin may then be set to a logic-1 state to start the initialization sequence.

Table 2. System Clock Rates for Common Audio Sampling Frequencies

| SAMPLING FREQUENCY | SYSTEM CLOCK FREQUENCY (f_{SCLK}) (MHz) | | | | | |
|--------------------|---|-----------|-----------|-----------|-----------|-----------|
| | $128 f_s$ | $192 f_s$ | $256 f_s$ | $384 f_s$ | $512 f_s$ | $768 f_s$ |
| 32 kHz | 4.096 | 6.144 | 8.192 | 12.288 | 16.384 | 24.576 |
| 44.1 kHz | 5.6488 | 8.4672 | 11.2896 | 16.9344 | 22.5792 | 33.8688 |
| 48 kHz | 6.144 | 9.216 | 12.288 | 18.432 | 24.576 | 36.864 |
| 96 kHz | 12.288 | 18.432 | 24.576 | 36.864 | 49.152 | 73.728 |
| 192 kHz | 24.576 | 36.864 | 49.152 | 73.728 | (1) | (1) |

(1) This system clock is not supported for the given sampling frequency.

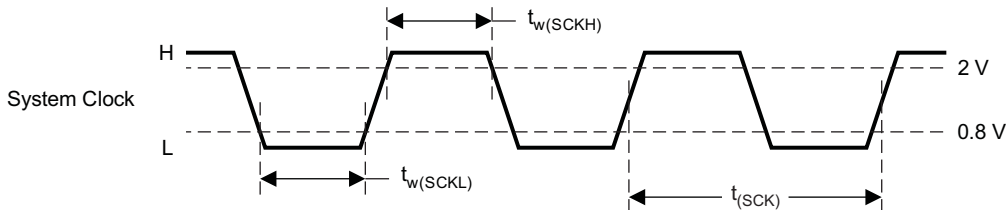

T0005-13

| PARAMETER | MIN | MAX | UNIT |
|---|-----|-----|------|
| $t_{(SCK)}$ System clock cycle time | 13 | | ns |
| $t_{w(SCKH)}$ System clock pulse duration, HIGH | 5 | | ns |
| $t_{w(SCKL)}$ System clock pulse duration, LOW | 5 | | ns |

Figure 32. System Clock Input Timing

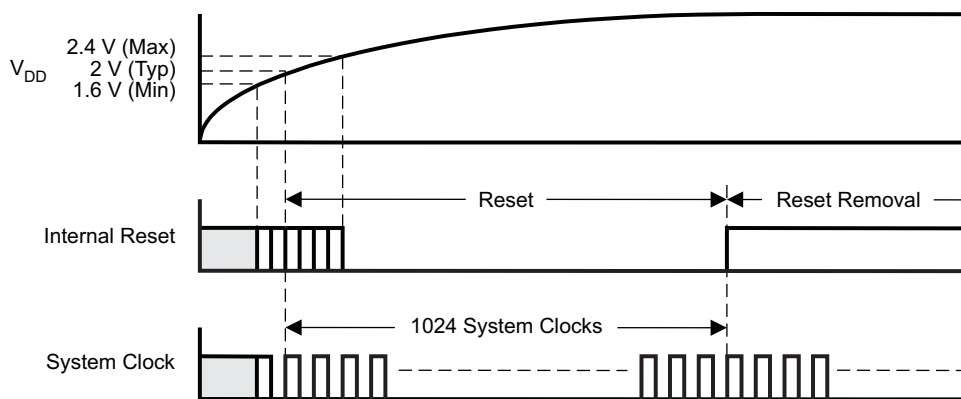

T0014-11

Figure 33. Power-On-Reset Timing

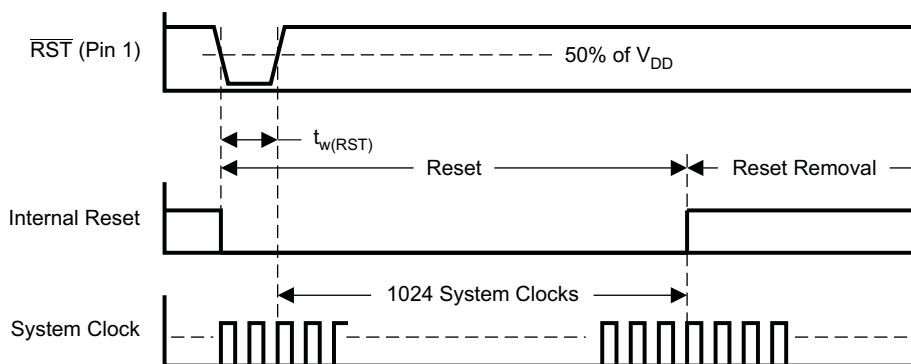

T0015-07

| PARAMETER | MIN | MAX | UNIT |
|--|-----|-----|------|
| $t_{w(RST)}$ Reset pulse duration, LOW | 20 | | ns |

Figure 34. External Reset Timing

AUDIO DATA INTERFACE

AUDIO SERIAL INTERFACE

The audio serial interface for the PCM1738 consists of a 3-wire synchronous serial port. It includes LRCK (pin 4), BCK (pin 6), and DATA (pin 5). BCK is the serial audio bit clock, used to clock the serial data present on DATA into the audio interface serial shift register. Serial data is clocked into the PCM1738 on the rising edge of BCK. LRCK is the serial audio left/right word clock, used to latch serial data into the serial audio interface internal registers.

LRCK should be synchronous to the system clock. In the event these clocks are not synchronized, the PCM1738 can compensate for the phase difference internally. If the phase difference between LRCK and SCKI is greater than six bit clocks (BCK), the synchronization is performed internally. While the synchronization is processing, the analog output is forced to the bipolar zero level. The synchronization typically occurs in less than one cycle of LRCK.

Ideally, it is recommended that LRCK and BCK be derived from the system clock input or output, SCKI or SCKO. The left/right clock (LRCK) is operated at the sampling frequency, f_s .

AUDIO DATA FORMATS AND TIMING

The PCM1738 supports industry-standard audio data formats, including standard right-justified, I²S, and left-justified. The data formats are shown in [Figure 35](#). Data formats are selected using the format bits, FMT [2:0], in mode control register 18. The default data format is 16-bit standard. All formats require binary 2s-complement, MSB-first audio data. [Figure 36](#) shows a detailed timing diagram for the serial audio interface.

(1) Standard Data Format (Right-Justified): L-Channel = HIGH, R-Channel = LOW

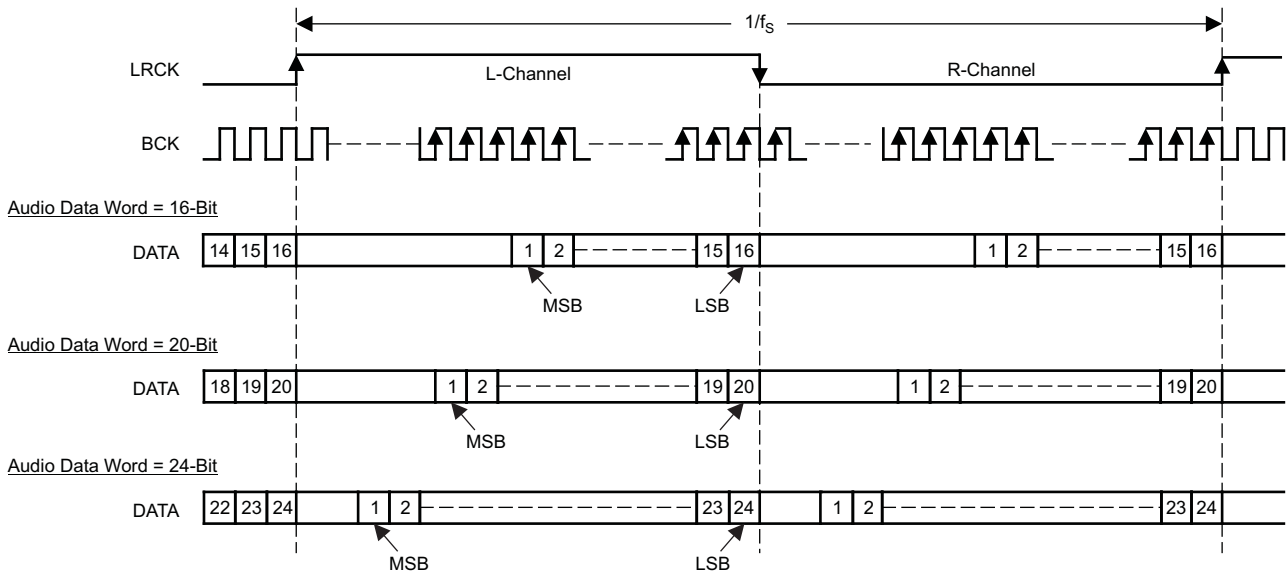

(2) Left-Justified Data Format: L-Channel = HIGH, R-Channel = LOW

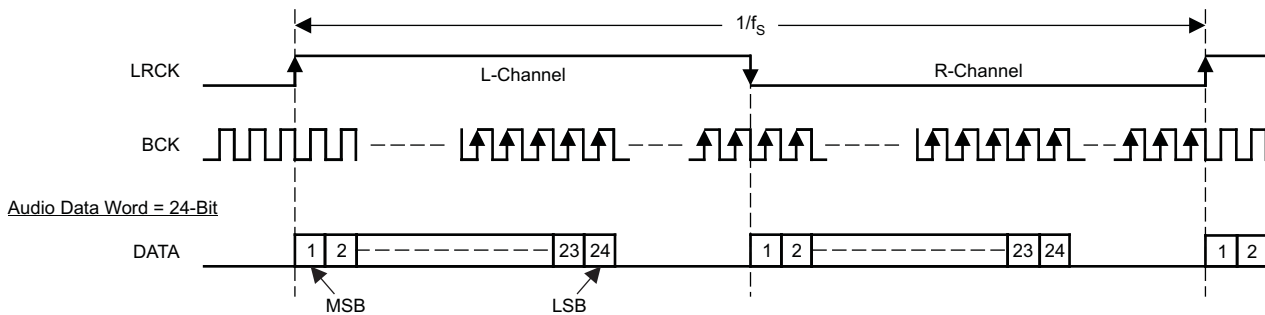

(3) I²S Data Format: L-Channel = LOW, R-Channel = HIGH

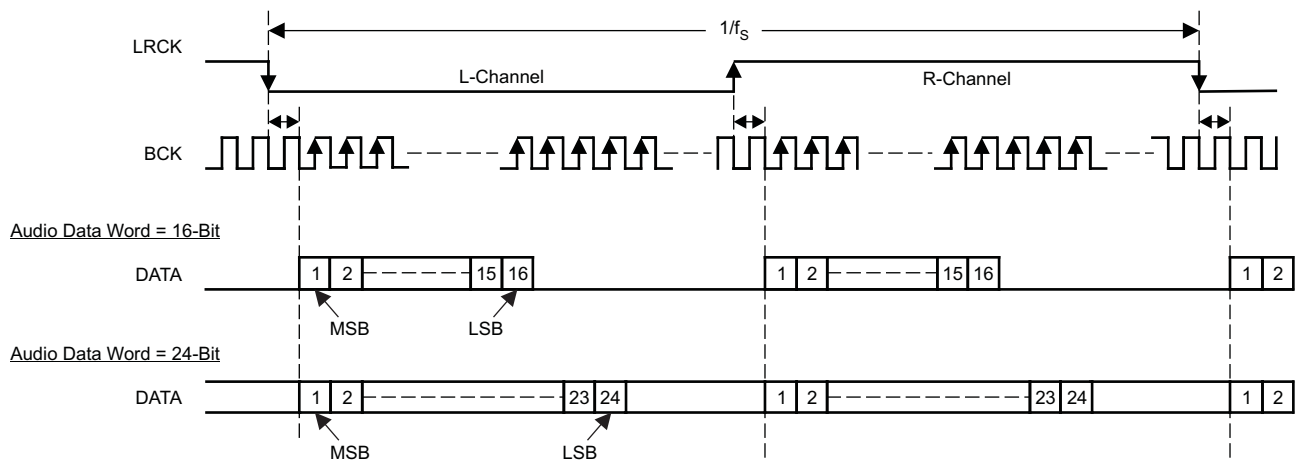

T0009-08

Figure 35. Audio Data Input Formats

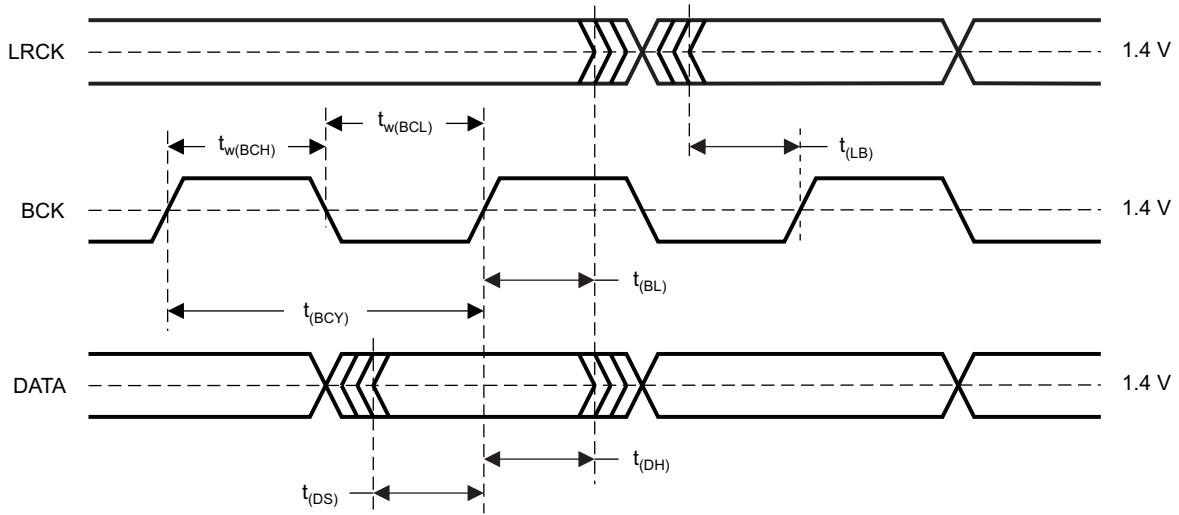

T0010-10

| PARAMETER | | MIN | MAX | UNIT |
|--------------|--------------------------------------|--------------------|--------------------|------|
| $t_{(BCY)}$ | BCK clock cycle time | 70 | | ns |
| $t_{w(BCL)}$ | BCK low-level time | 30 | | ns |
| $t_{w(BCH)}$ | BCK high-level time | 30 | | ns |
| $t_{(BL)}$ | BCK rising edge to LRCK edge | 10 | | ns |
| $t_{(LB)}$ | LRCK falling edge to BCK rising edge | 10 | | ns |
| $t_{(DS)}$ | DATA setup time | 10 | | ns |
| $t_{(DH)}$ | DATA hold time | 10 | | ns |
| — | LRCK clock duty cycle | 50% – 2 bit clocks | 50% + 2 bit clocks | |

Figure 36. Audio Interface Timing

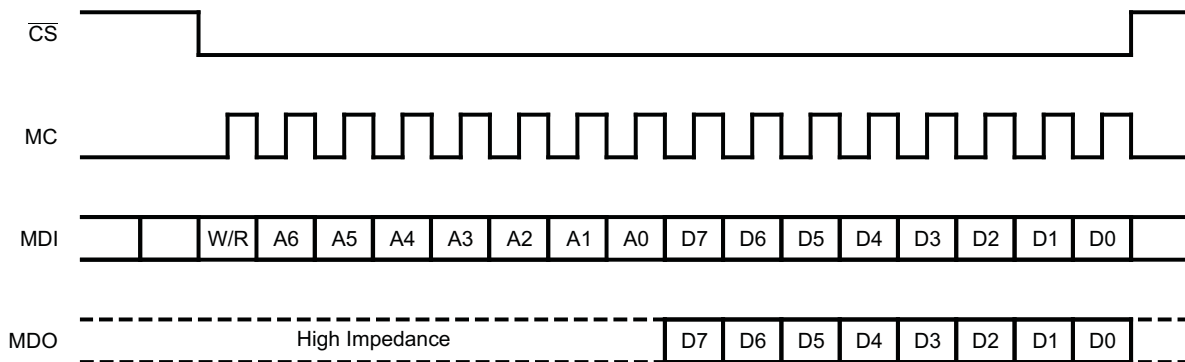

When Read Mode is Instructed

T0048-05

NOTE: B15 is used for the selection of write or read. Setting W/R = 0 indicates a write, while W/R = 1 indicates a read.
B14–B8 are used for the register address.
B7–B0 are used for register data.

Figure 37. Serial Control Format

EXTERNAL DIGITAL FILTER INTERFACE AND TIMING

The PCM1738 supports an external digital-filter interface comprised of a 4-wire synchronous serial port that allows the use of an external digital filter. External filters include the DF1704 and DF1706 from Texas Instruments, the Pacific Microsonics PMD200, or a programmable digital signal processor.

The 4-wire interface includes WDCK as the word clock, BCK as the bit clock, DATAL as the L-channel data, and DATAR as the R-channel data. The external digital-filter interface is selected using the DFTH bit of mode control register 20, which functions to bypass the internal digital-filter portion of the PCM1738. The 4-wire serial port is assigned to WDCK (pin 4), BCK (pin 6), DATAL (pin 5), and DATAR (pin 15).

DSD (DIRECT STREAM DIGITAL) FORMAT INTERFACE AND TIMING

The PCM1738 supports a DSD format interface operation that includes out-of-band noise filtering using an internal analog FIR filter. For DSD operation, pin 7 is redefined as BCK, which operates at 64×44.1 kHz; pin 5 is redefined as DATAL (left-channel audio data), and pin 15 becomes DATAR (right-channel audio data). Pins 4 and 6 must be forced LOW in DSD mode. This configuration allows for direct interface to a DSD decoder for SACD applications. Detailed information for the DSD mode is provided in the [Application for DSD Format \(DSD Mode\) Interface](#) section of this data sheet.

FUNCTIONAL DESCRIPTIONS

ZERO DETECT

When the PCM1738 detects that the audio input data in the L-channel or R-channel is continuously zero for 1024 LRCKs, the PCM1738 sets ZEROL (pin 2) or ZEROR (pin 3) to HIGH. Setting the INZD bit of mode control register 19 can set both analog outputs to the bipolar zero level when the input data of both channels is zero.

SOFT MUTE

The PCM1738 supports mute operation by both hardware and software control. When MUTE (pin 15) is set to HIGH, both analog outputs are turned to the bipolar zero level. When the MUTE bit in mode control register 18 is set to 1, both analog outputs are also turned to the bipolar zero level. The speed to turn to the bipolar zero level is set by the ATS0 and ATS1 bits in mode control register 19.

SERIAL CONTROL INTERFACE

The serial control interface is a 4-wire synchronous serial port that operates asynchronously to the serial audio interface and the system clock (SCKI). The serial control interface is used to program the on-chip mode control registers. The control interface includes MDO (pin 11), MDI (pin 12), MC (pin 13), and \overline{CS} (pin 14). MDO is the serial data output, used to read back the values of the mode control registers; MDI is the serial data input, used to program the mode control registers; MC is the serial bit clock, used to shift data in and out of the control port; and \overline{CS} is the mode control enable, used to enable the internal mode control register access. [Figure 37](#) and [Figure 38](#) show the format and timing for the serial control interface.

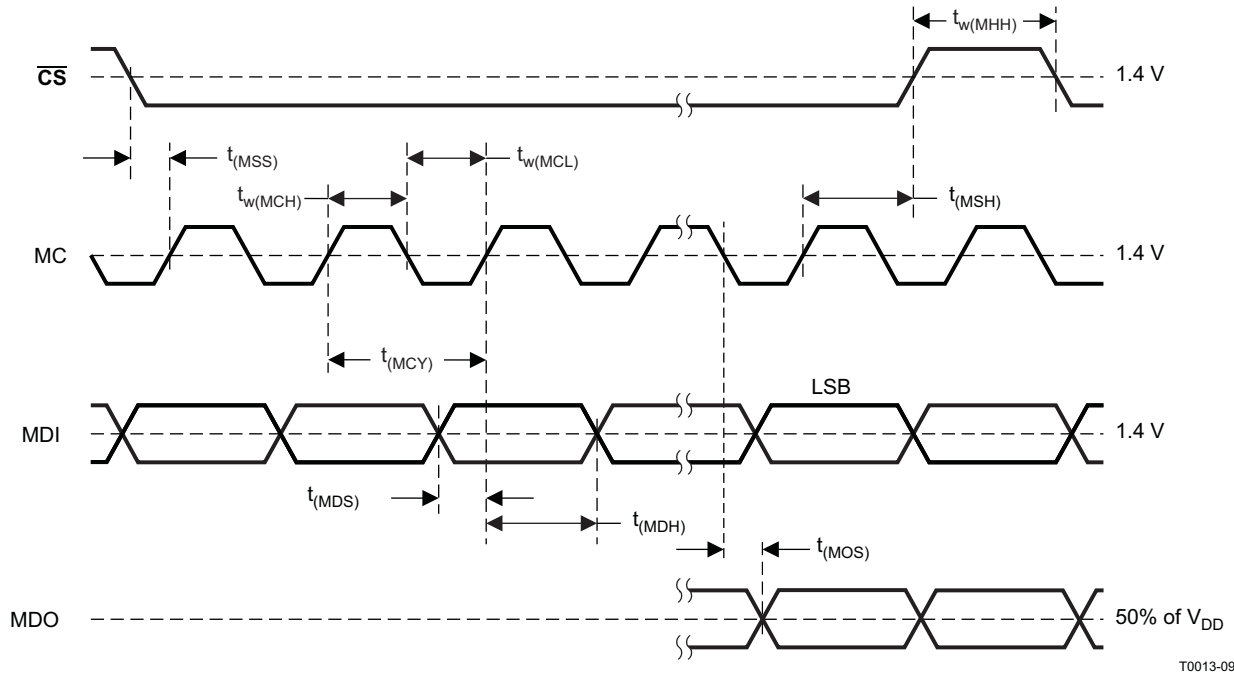

T0013-09

| PARAMETER | | MIN | MAX | UNIT |
|--------------|--|-----|-----|------|
| $t_{(MCY)}$ | MC clock cycle time | 100 | | ns |
| $t_{w(MCL)}$ | MC low-level time | 40 | | ns |
| $t_{w(MCH)}$ | MC high-level time | 40 | | ns |
| $t_{(MHH)}$ | \overline{CS} high-level time | 80 | | ns |
| $t_{(MSS)}$ | \overline{CS} falling edge to MC rising edge | 15 | | ns |
| $t_{(MSH)}$ | \overline{CS} hold time ⁽¹⁾ | 15 | | ns |
| $t_{(MDH)}$ | MDI hold time | 15 | | ns |
| $t_{(MDS)}$ | MDI setup time | 15 | | ns |
| $t_{(MOS)}$ | MC falling edge to MDO stable | | 30 | ns |

(1) MC rising edge for LSB to \overline{CS} rising edge

Figure 38. Control Interface Timing

MODE CONTROL REGISTERS

User-Programmable Mode Controls

The PCM1738 includes a number of user-programmable functions that are accessed via mode control registers. The registers are programmed using the serial control interface that was previously discussed in this data sheet. Table 3 lists the available mode control functions, along with their reset default conditions and associated register index.

Register Map

The mode control register map is shown in Table 4. Each register includes a W/R bit that indicates whether a register read (W/R = 1) or write (W/R = 0) operation is performed.

Table 3. User-Programmable Mode Controls

| FUNCTION | DEFAULT | REGISTER | BIT |
|--|-----------------------------------|--------------------------------------|--|
| FUNCTIONS AVAILABLE FOR BOTH WRITE AND READ | | | |
| Digital attenuation control 0 dB to –120 dB in 0.5-dB steps | 0 dB | 16 for L-channel 17 for R-channel | ATL[7:0] ATR[7:0] |
| Attenuation load control Disabled, enabled | Attenuation disabled | 18 | ATLD |
| Attenuation speed selection $\times 1 f_s$, $\times (1/2) f_s$, $\times (1/4) f_s$, $\times (1/8) f_s$ | $\times 1 f_s$ | 19 | ATS[1:0] |
| Soft mute control Mute disabled, enabled | Mute disabled | 18 | MUTE |
| Infinite zero mute control Disabled, enabled | Disabled | 19 | INZD |
| Input audio data format selection 16-, 20-, 24-bit standard (right-justified) format 24-bit, MSB-first, left-justified format 16-, 24-bit I ² S format | 16-bit standard format | 18 | FMT[2:0] |
| De-emphasis control Disabled, enabled | De-emphasis disabled | 18 | DME |
| Sampling rate selection for de-emphasis Disabled, 44.1 kHz, 48 kHz, 32 kHz | De-emphasis disabled | 18 | DMF[1:0] |
| Digital filter rolloff selection Sharp rolloff, slow rolloff | Sharp rolloff | 19 | FLT |
| Output phase reversal Normal, reversed | Normal | 19 | REV |
| DAC operation control Enabled, disabled | DAC operation enabled | 19 | OPE |
| System clock (SCKO) output control Output Enabled, disabled | Output enabled | 19 | CLKE |
| System clock (SCKO) rate control SCKI, SCKI/2 | SCKI | 19 | CLKD |
| System reset control Reset operation, normal operation | Normal operation | 20 | SRST |
| Mode control register reset control Reset operation, normal operation | Normal operation | 20 | MRST |
| Digital-filter bypass control DF enabled, DF bypassed | DF enabled | 20 | DFTH |
| Delta-sigma oversampling rate selection $\times 64 f_s$, $\times 128 f_s$, $\times 32 f_s$ | $\times 64 f_s$ | 20 | OS[1:0] |
| Monaural mode selection Stereo, monaural | Stereo | 20 | MONO |
| Channel selection for monaural mode data L-channel, R-channel | L-channel | 20 | CHSL |
| FUNCTIONS AVAILABLE ONLY FOR READ | | | |
| Zero detection flag Not zero, zero detected | Not zero = 0 Zero detected = 1 | 21 | ZFGL for L-channel ZFGR for R-channel |

Table 4. Mode Control Register Map

| REGISTER | B15 | B14 | B13 | B12 | B11 | B10 | B9 | B8 | B7 | B6 | B5 | B4 | B3 | B2 | B1 | B0 |
|----------|-----|-----|-----|-----|-----|-----|----|----|--------------------|--------------------|--------------------|--------------------|--------------------|--------------------|------|------|
| 16 | W/R | 0 | 0 | 1 | 0 | 0 | 0 | 0 | ATL7 | ATL6 | ATL5 | ATL4 | ATL3 | ATL2 | ATL1 | ATL0 |
| 17 | W/R | 0 | 0 | 1 | 0 | 0 | 0 | 1 | ATR7 | ATR6 | ATR5 | ATR4 | ATR3 | ATR2 | ATR1 | ATR0 |
| 18 | W/R | 0 | 0 | 1 | 0 | 0 | 1 | 0 | ATLD | FMT2 | FMT1 | FMT0 | DMF1 | DMF0 | DME | MUTE |
| 19 | W/R | 0 | 0 | 1 | 0 | 0 | 1 | 1 | REV | ATS1 | ATS0 | OPE | CLKD | CLKE | FLT | INZD |
| 20 | W/R | 0 | 0 | 1 | 0 | 1 | 0 | 0 | RSV ⁽¹⁾ | SRST | MRST | DFTH | MONO | CHSL | OS1 | OS0 |
| 21 | R | 0 | 0 | 1 | 0 | 1 | 0 | 1 | RSV ⁽¹⁾ | RSV ⁽¹⁾ | RSV ⁽¹⁾ | RSV ⁽¹⁾ | RSV ⁽¹⁾ | RSV ⁽¹⁾ | ZFGR | ZFGL |

(1) RSV is assigned for factory test operation.

REGISTER DEFINITIONS

| | B15 | B14 | B13 | B12 | B11 | B10 | B9 | B8 | B7 | B6 | B5 | B4 | B3 | B2 | B1 | B0 |
|-------------|-----|-----|-----|-----|-----|-----|----|----|------|------|------|------|------|------|------|------|
| REGISTER 16 | W/R | 0 | 0 | 1 | 0 | 0 | 0 | 0 | ATL7 | ATL6 | ATL5 | ATL4 | ATL3 | ATL2 | ATL1 | ATL0 |
| REGISTER 17 | W/R | 0 | 0 | 1 | 0 | 0 | 0 | 1 | ATR7 | ATR6 | ATR5 | ATR4 | ATR3 | ATR2 | ATR1 | ATR0 |

W/R Read/Write Mode Select

When W/R = 0, a write operation is performed.

When W/R = 1, a read operation is performed.

Default value: 0

ATL/R[7:0] Digital Attenuation Level Setting

These bits are read/write.

Default value: 1111 1111b

Each DAC output has a digital attenuator associated with it. The attenuator may be set from 0 db to -120 dB, in 0.5-dB steps. Alternatively, the attenuator may be set to infinite attenuation (or mute).

The attenuation data for each channel can be set individually. However, the data load control (ATLD bit of mode control register 18) is common to both attenuators. ATLD must be set to 1 in order to change an attenuator's setting. The attenuation level may be set using the following formula:

$$\text{Attenuation level (dB)} = 0.5 \text{ dB} \times (\text{ATL/R}[7:0]_{\text{DEC}} - 255)$$

where $\text{ATL/R}[7:0]_{\text{DEC}} = 0$ through 255

For $\text{ATL/R}[7:0]_{\text{DEC}} = 0$ through 14, the attenuator is set to infinite attenuation.

The following table shows attenuator levels for various settings.

| ATL/R[7:0] | Decimal Value | Attenuator Level Setting |
|------------|---------------|--------------------------------|
| 1111 1111b | 255 | 0 dB, no attenuation (default) |
| 1111 1110b | 254 | -0.5 dB |
| 1111 1101b | 253 | -1 dB |
| • | • | • |
| • | • | • |
| 0001 0000b | 16 | 119.5 dB |
| 0000 1111b | 15 | 120 dB |
| 0000 1110b | 14 | Mute |
| • | • | • |
| • | • | • |
| 0000 0000b | 0 | Mute |

| | B15 | B14 | B13 | B12 | B11 | B10 | B9 | B8 | B7 | B6 | B5 | B4 | B3 | B2 | B1 | B0 |
|-------------|-----|-----|-----|-----|-----|-----|----|----|------|------|------|------|------|------|-----|------|
| REGISTER 18 | W/R | 0 | 0 | 1 | 0 | 0 | 1 | 0 | ATLD | FMT2 | FMT1 | FMT0 | DMF1 | DMF0 | DME | MUTE |

W/R Read/Write Mode Control

When W/R = 0, a write operation is performed.

When W/R = 1, a read operation is performed.

Default value: 0

ATLD Attenuation Load Control

This bit is read/write.

Default value: 0

| | |
|----------|--|
| ATLD = 0 | Attenuation control disabled (default) |
| ATLD = 1 | Attenuation control enabled |

The ATLD bit is used to enable loading of attenuation data set by registers 16 through 17. When ATLD = 0, the attenuation settings remain at the previously programmed level, ignoring new data loaded to registers 16 through 17. When ATLD = 1, attenuation data written to registers 16 through 17 is loaded normally.

FMT[2:0] Audio Interface Data Format

These bits are read/write.

Default value: 000

| FMT[2:0] | Audio Data Format Selection |
|----------|---|
| 000 | 16-bit, standard-format, right-justified data (default) |
| 001 | 20-bit, standard-format, right-justified data |
| 010 | 24-bit, standard-format, right-justified data |
| 011 | 24-bit, MSB-first, left-justified format data |
| 100 | 16-bit, I ² S-format data |
| 101 | 24-bit, I ² S-format data |
| 110 | Reserved |
| 111 | Reserved |

The FMT[2:0] bits are used to select the data format for the serial audio interface.

For external digital-filter interface mode (DFTH mode), this register is operated as shown in the [Application for External Digital Filter Interface](#) section of this data sheet.

DMF[1:0] Sampling Frequency Selection for the De-Emphasis Function

These bits are read/write.

Default value: 00

| DMF[1:0] | De-Emphasis Same Rate Selection |
|-----------------|--|
| 00 | Disabled (default) |
| 01 | 48 kHz |
| 10 | 44.1 kHz |
| 11 | 32 kHz |

The DMF[1:0] bits are used to select the sampling frequency used for the digital de-emphasis function when it is enabled by setting the DME bit. The de-emphasis curves are shown in the [Typical Performance Curves](#) section of this data sheet.

For DSD mode, analog FIR filter performance may be selected using this register. Filter response plots are shown in the [Typical Performance Curves](#) section of this data sheet. The register map is shown in the [Application for DSD Format \(DSD Mode\) Interface](#) section of this data sheet.

DME Digital De-Emphasis Control

This bit is read/write.

Default value: 0

For DSD mode, DME must be set to 1.

| | |
|---------|--------------------------------|
| DME = 0 | De-emphasis disabled (default) |
| DME = 1 | De-emphasis enabled |

The DME bit is used to enable or disable the de-emphasis function for both channels.

MUTE Soft-Mute Control

This bit is read/write.

Default value: 0

| | |
|----------|-------------------------|
| MUTE = 0 | MUTE disabled (default) |
| MUTE = 1 | MUTE enabled |

The MUTE bit is used to enable the soft-mute function for both channels. The mute function is also available through the MUTE control input (pin 15). Soft mute is performed by using the 256-step attenuator, cycling one step per time interval to – (mute). The time interval is set by the rate select bit (ATS), located in register 19.

| | | | | | | | | | | | | | | | | |
|-------------|-----|-----|-----|-----|-----|-----|----|----|-----|------|------|-----|------|------|-----|------|
| | B15 | B14 | B13 | B12 | B11 | B10 | B9 | B8 | B7 | B6 | B5 | B4 | B3 | B2 | B1 | B0 |
| REGISTER 19 | W/R | 0 | 0 | 1 | 0 | 0 | 1 | 1 | REV | ATS1 | ATS0 | OPE | CLKD | CLKE | FLT | INZD |

W/R Read/Write Mode Control

When W/R = 0, a write operation is performed.

When W/R = 1, a read operation is performed.

Default value: 0

REV Output Phase Reversal

This bit is read/write.

Default value: 0

| | |
|---------|-------------------------|
| REV = 0 | Normal output (default) |
| REV = 1 | Inverted output |

The REV bit is used to invert the output phase for both the left and right channels.

ATS[1:0] Attenuation Rate Select

This bit is read/write.

Default value: 00

| ATS[1:0] | Attenuation Rate Selection |
|----------|----------------------------|
| 00 | LRCK (default) |
| 01 | $1/2 \times \text{LRCK}$ |
| 10 | $1/4 \times \text{LRCK}$ |
| 11 | $1/8 \times \text{LRCK}$ |

The ATS[1:0] bits are used to select the rate at which the attenuator is decremented or incremented during level transitions.

OPE DAC Operation Control

This bit is read/write.

Default value: 0

| | |
|---------|---------------------------------|
| OPE = 0 | DAC operation enabled (default) |
| OPE = 1 | DAC operation disabled |

The OPE bit is used to enable or disable the analog output for both channels. Disabling the analog outputs forces them to the bipolar zero level (BPZ), ignoring the audio data input(s).

CLKD SCKO Frequency Selection

This bit is read/write.

Default value: 0

| | |
|----------|--|
| CLKD = 0 | Full-rate, $f_{\text{SCKO}} = f_{\text{SCKI}}$ (default) |
| CLKD = 1 | Half-rate, $f_{\text{SCKO}} = f_{\text{SCKI}}/2$ |

The CLKD bit is used to determine the output frequency at the system clock output pin, SCKO.

CLKE SCKO Output Enable

This bit is read/write.

Default value: 0

| | |
|----------|------------------------|
| CLKE = 0 | SCKO enabled (default) |
| CLKE = 1 | SCKO disabled |

The CLKE bit is used to enable or disable the system clock output pin, SCKO.

FLT Digital Filter Rolloff Control

This bit is read/write.

Default value: 0

| | |
|---------|-------------------------|
| FLT = 0 | Sharp rolloff (default) |
| FLT = 1 | Slow rolloff |

The FLT bit allows the user to select the digital filter rolloff characteristics. The filter responses for these selections are shown in the [Typical Performance Curves](#) section of this data sheet.

INZD Infinite Zero Detect Mute Control

This bit is read/write.

Default value: 0

| | |
|----------|--|
| INZD = 0 | Infinite zero detect mute disabled (default) |
| INZD = 1 | Infinite zero detect mute enabled |

The INZD bit is used to enable or disable the zero detect mute function. Setting INZD = 1 allows the analog outputs to be set to the bipolar zero level when the PCM1738 detects zero data for both left and right channels for 1024 sampling periods (or LRCK cycles).

| | B15 | B14 | B13 | B12 | B11 | B10 | B9 | B8 | B7 | B6 | B5 | B4 | B3 | B2 | B1 | B0 |
|-------------|-----|-----|-----|-----|-----|-----|----|----|-----|------|------|------|------|------|-----|-----|
| REGISTER 20 | W/R | 0 | 0 | 1 | 0 | 1 | 0 | 0 | RSV | SRST | MRST | DFTH | MONO | CHSL | OS1 | OS0 |

W/R Read/Write Mode Control

When W/R = 0, a write operation is performed.

When W/R = 1, a read operation is performed.

Default value: 0

SRST System Reset Control

This bit is read/write.

Default value: 0

SRST = 0 Normal operation (default)

SRST = 1 System reset operation

The SRST bit is used to reset the PCM1738 to the initial system condition.

MRST Mode Control Register Reset Control

This bit is read/write.

Default value: 0

MRST = 0 Normal operation (default)

MRST = 1 Mode control register reset operation

The MRST bit is used to set the mode control registers to their default conditions.

DFTH Digital Filter Bypass (or Through-Mode) Control

This bit is read/write.

Default value: 0

DFTH = 0 Digital filter enabled (default)

DFTH = 1 Digital filter bypassed for either external-digital-filter mode or DSD mode

The DFTH bit is used to enable or bypass the internal digital filter. This function is used when using the external-digital-filter interface or the DSD-mode interface.

MONO Monaural Mode Selection

This bit is read/write.

Default value: 0

MONO = 0 Stereo mode (default)

MONO = 1 Monaural mode

The MONO function is used to change the operation mode from normal stereo mode to monaural mode. When the monaural mode is selected, both DACs operate in balanced mode for the selected audio input data. Left- and right-channel data selection is set by the CHSL bit, described as follows.

CHSL Channel Selection for Monaural Mode

This bit is read/write.

Default value: 0

This bit is available when MONO = 1.

CHSL = 0 L-channel selected (default)
 CHSL = 1 R-channel selected

The CHSL bit is used to set the audio data selection for the monaural mode.

OS[1:0] Delta-Sigma Oversampling Rate Selection

These bits are available for read/write.

Default value: 00

For DSD mode, this register is used to select the speed of BCK (pin 7) for the analog FIR filter.

| OS[1:0] | Operation Speed Select |
|---------|------------------------|
| 00 | 64× (default) |
| 01 | Reserved |
| 10 | 128× |
| 11 | 32× |

The OS bits are used to change the oversampling ratio of the delta-sigma modulator. This function is useful when considering the output low-pass filter design that can handle a wide range of sampling rates. As an example, selecting 128× for $f_s = 44.1$ kHz, 64× for $f_s = 96$ kHz, and 32× for $f_s = 192$ kHz operation would require a low-pass filter with a single cutoff frequency to accommodate all three sampling rates.

| | B15 | B14 | B13 | B12 | B11 | B10 | B9 | B8 | B7 | B6 | B5 | B4 | B3 | B2 | B1 | B0 |
|-------------|-----|-----|-----|-----|-----|-----|----|----|-----|-----|-----|-----|-----|-----|------|------|
| REGISTER 21 | R | 0 | 0 | 1 | 0 | 1 | 0 | 1 | RSV | RSV | RSV | RSV | RSV | RSV | ZFGR | ZFGL |

R Read Mode Control

Only set to 1 for read-back mode.

ZFGx Zero Detection Flag

When x = L or R, corresponding to the DAC output channel.

These bits are available only for readback.

Default value: 00

ZFGx = 0 Not ZERO
 ZFGx = 1 ZERO detected

When the PCM1738 detects that audio input data is continuously zero for 1024 LRCKs, the ZFGx bit is set to 1 for the corresponding channel(s). Zero detect flags are also available at ZEROL (pin 2) and ZEROR (pin 3).

TYPICAL CONNECTION DIAGRAM IN PCM MODE

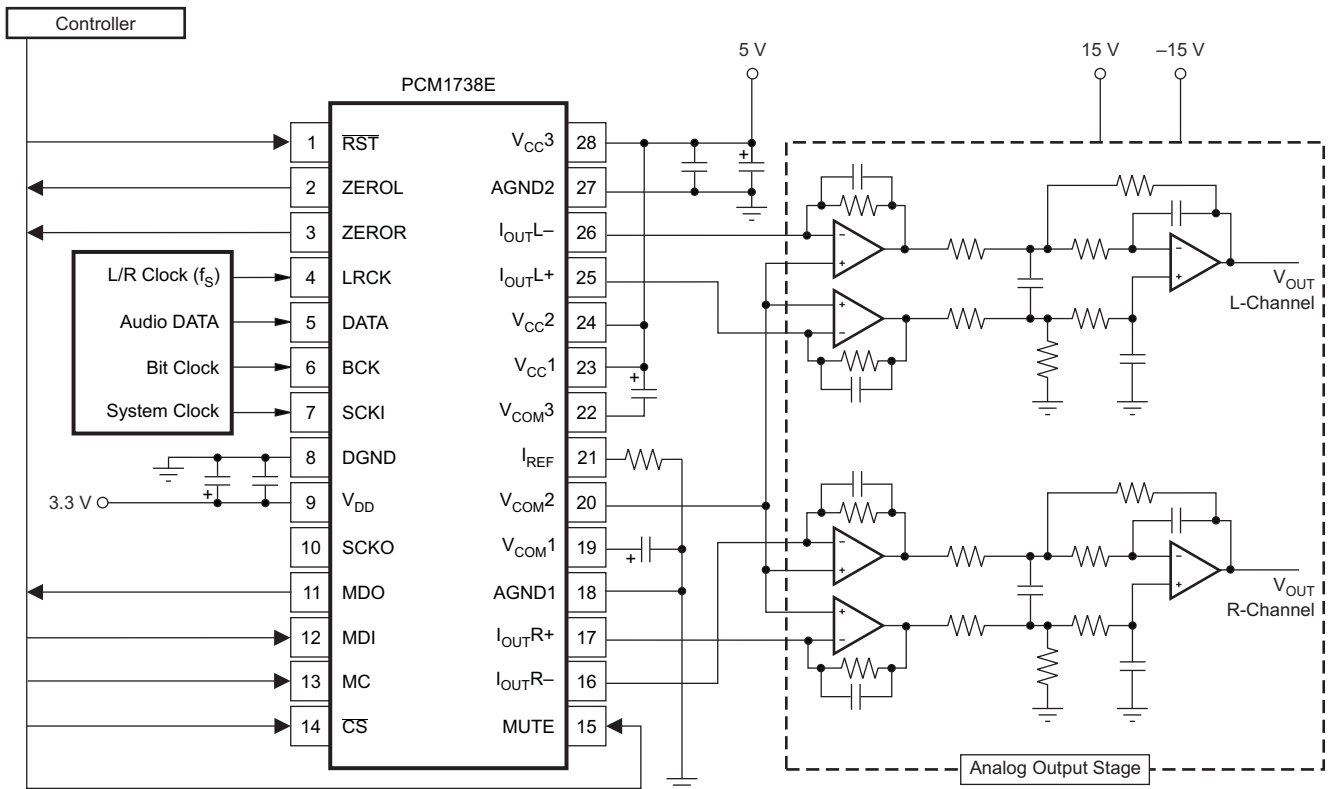

S0241-01

NOTE: Regarding R/C values for the analog output stage, see [Figure 40](#).

Figure 39. Typical Application Circuit for Standard PCM Audio Operation

ANALOG OUTPUTS

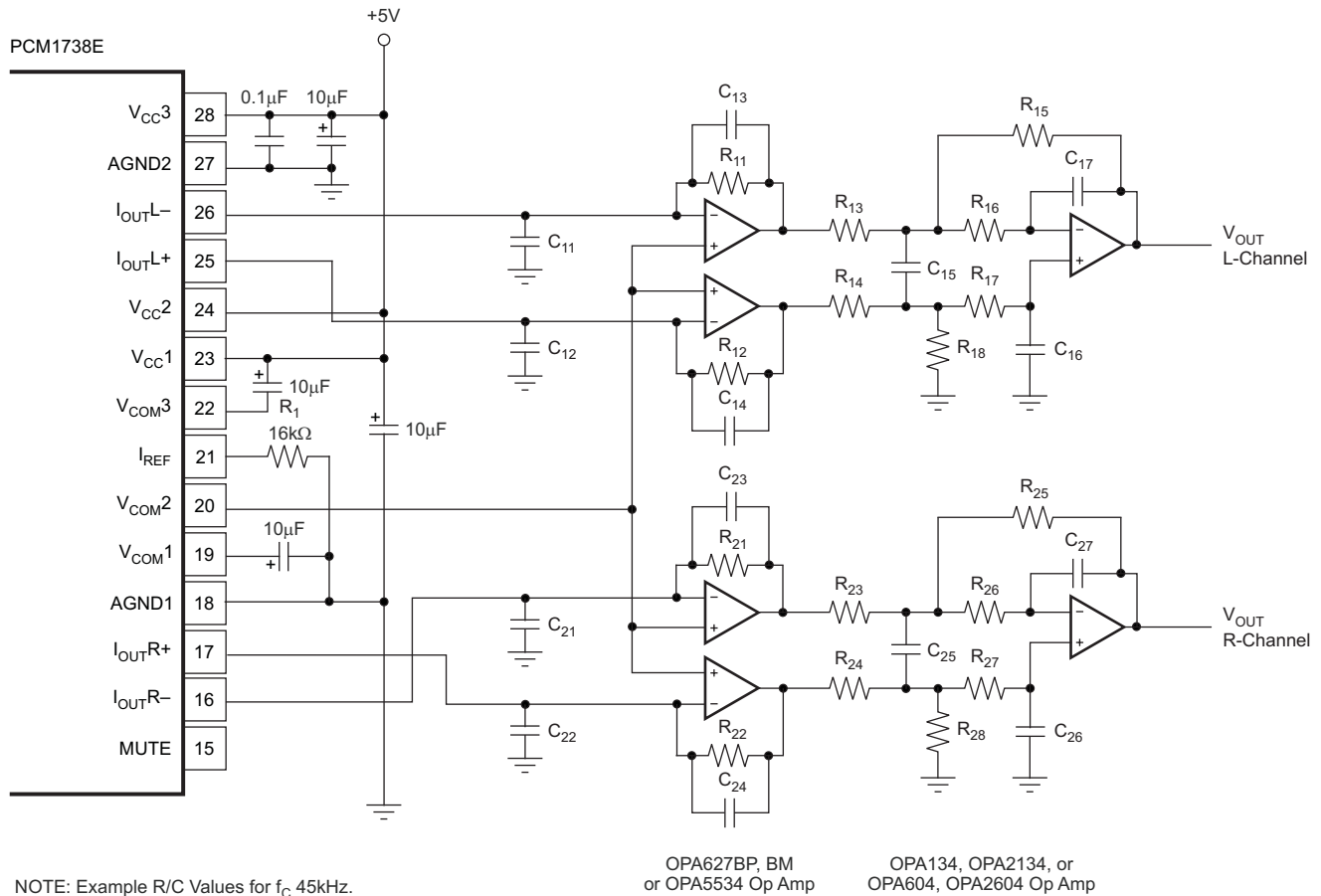

S0242-01

Figure 40. Typical Application for Analog Output Stage

ANALOG OUTPUT LEVEL AND I/V CONVERTER

The signal level of the DAC current output pins (I_{OUTL+} , I_{OUTL-} , I_{OUTR+} , and I_{OUTR-}) is ± 2.48 mA p-p at 0 dB (full scale). The voltage output of the I/V converter is given by the following equation:

$$V_{OUT} = \pm 2.48 \text{ mA p-p} \times R_F$$

Here, R_F is the feedback resistor in the I/V (current-to-voltage) conversion circuit, R_{11} , R_{12} , R_{21} , and R_{22} in the typical application circuit, Figure 40. The common level of the I/V conversion circuit must be the same as the common level of DAC I_{OUT} that is given by the V_{COM2} reference voltage, 2.5 V dc. The non-inverting inputs of the operational amplifiers shown in the I/V circuits are connected to V_{COM2} to provide the common bias voltage.

Operational Amplifiers for I/V Converter Circuit

The OPA627BP/BM, or 5534 type operational amplifier, is recommended for the I/V conversion circuit to obtain the specified audio performance. Dynamic performance, such as gain bandwidth, settling time, and slew rate of the operational amplifiers creates the audio dynamic performance of the I/V section. The input noise specification of the operational amplifiers should be considered to obtain 120-dB S/N ratio.

Analog Gain by Balanced Amplifier

The I/V converters are followed by balanced amplifier stages that sum the differential signals for each channel, creating a single-ended voltage output. In addition, the balanced amplifiers provide a second-order, low-pass filter function that band-limits the audio output signal. The cutoff frequency and gain is given by external R and C component values. In the case of [Figure 40](#), the cutoff frequency is 45 kHz with a gain of 1. The output voltage for each channel is 6.2 V_{p-p}, or 2.2 V_{rms}.

REFERENCE CURRENT RESISTOR

As shown in the analog output application circuit, marked R₁ on [Figure 40](#), there is a resistor connected from I_{REF} (pin 21) to the analog ground, designated as R₁. This resistor sets the current for the internal reference circuit. The value of R₁ must be 16 kΩ, ±1% in order to match the specified gain error shown in the [Electrical Characteristics](#) table.

APPLICATION FOR EXTERNAL DIGITAL FILTER INTERFACE

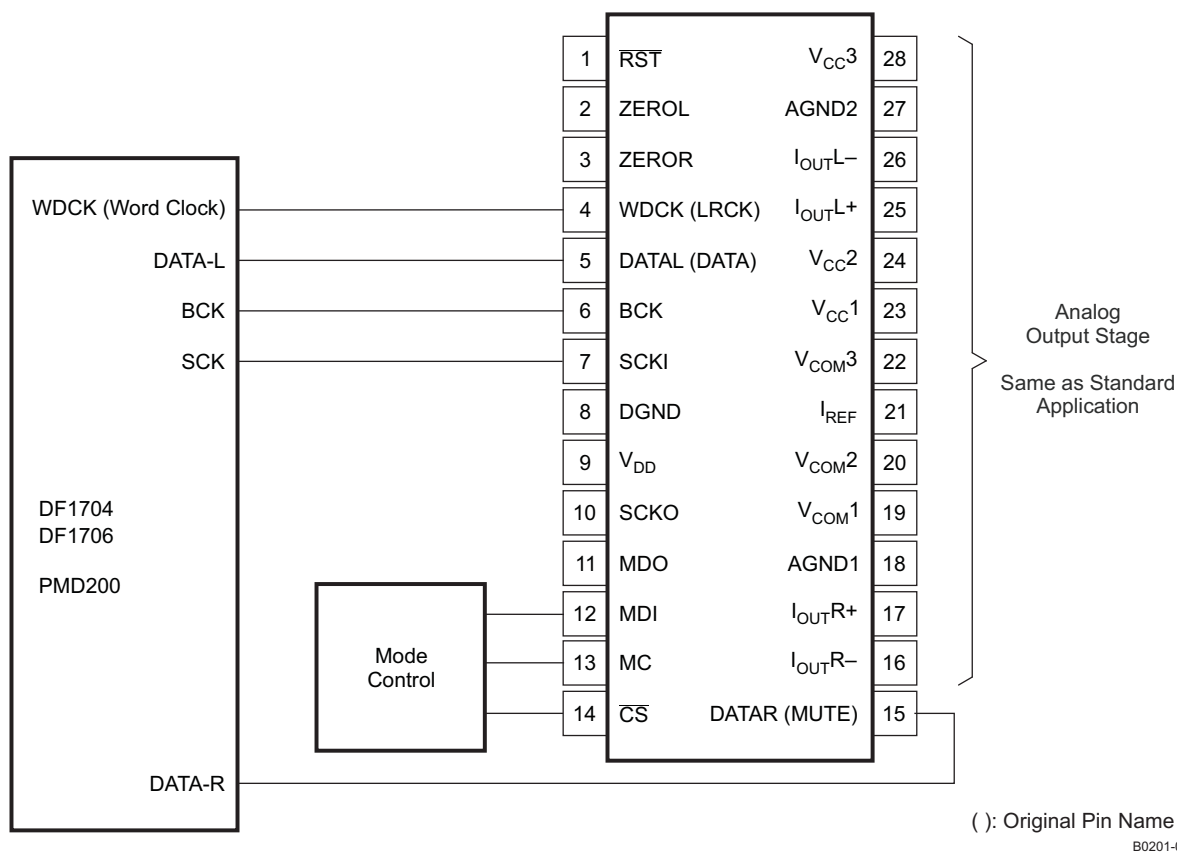

Figure 41. Connection Diagram for External Digital Filter (Internal DF Bypass Mode) Application

APPLICATIONS FOR INTERFACING WITH THE EXTERNAL DIGITAL FILTER

For some applications, it may be desirable to use an external digital filter to perform the interpolation function, as it may provide improved stop-band attenuation or other special features not available with the PCM1738's internal digital filter.

The PCM1738 supports the use of an external digital filter, including:

- The DF1704 and DF1706 from Texas Instruments
- Pacific Microsonics PMD100 HDCD filter/decoder ICs
- Programmable digital signal processors

The external digital-filter application mode is available by programming the following bits in the corresponding mode control registers:

- DFTH = 1 (register 20)
- DME = 0 (register 18)

The pins used to provide the serial interface for the external digital filter are shown in the application diagram of Figure 41. The word (WDCK) and bit (BCK) clock signals, as well as the audio data inputs (DATAL and DATAR) must be operated at $8\times$ or $4\times$ the original sampling frequency at the input of the digital filter.

SYSTEM CLOCK (SCKI) AND INTERFACE TIMING

The PCM1738, in external digital-filter mode, allows any system-clock frequency synchronized with BCK and WDCK. The system clock may be phase-free with BCK and WDCK. See Figure 43 for interface timing among WDCK, BCK, DATAL, and DATAR.

AUDIO FORMAT

In external digital-filter interface mode, the PCM1738 supports a right-justified audio format interface including 16-, 20-, and 24-bit audio data (see Figure 42) that should be selected by FMT[2:0] of mode control register 18.

FUNCTIONS AVAILABLE IN THE EXTERNAL DIGITAL-FILTER MODE

The external digital-filter mode allows access to the majority of the PCM1738's mode-control functions. Table 5 shows the register mapping available when the external digital-filter mode is selected, along with descriptions of functions that are modified for this mode selection.

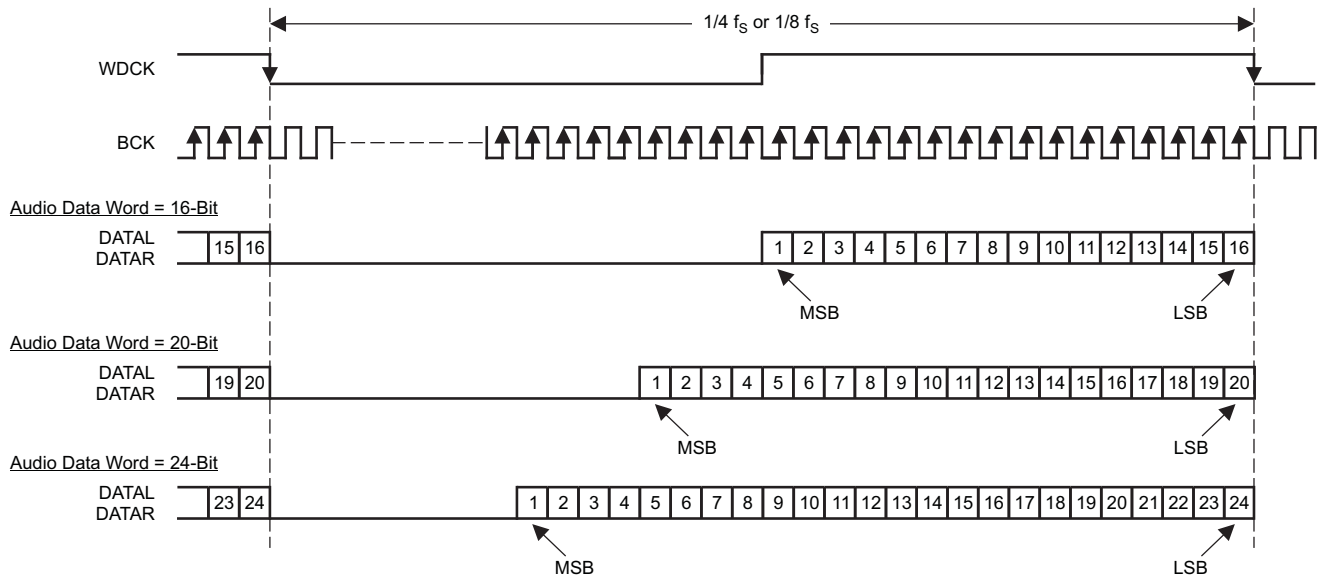

T0198-01

Figure 42. Audio Data Input Format for External Digital Filter (Internal DF Bypass Mode) Application

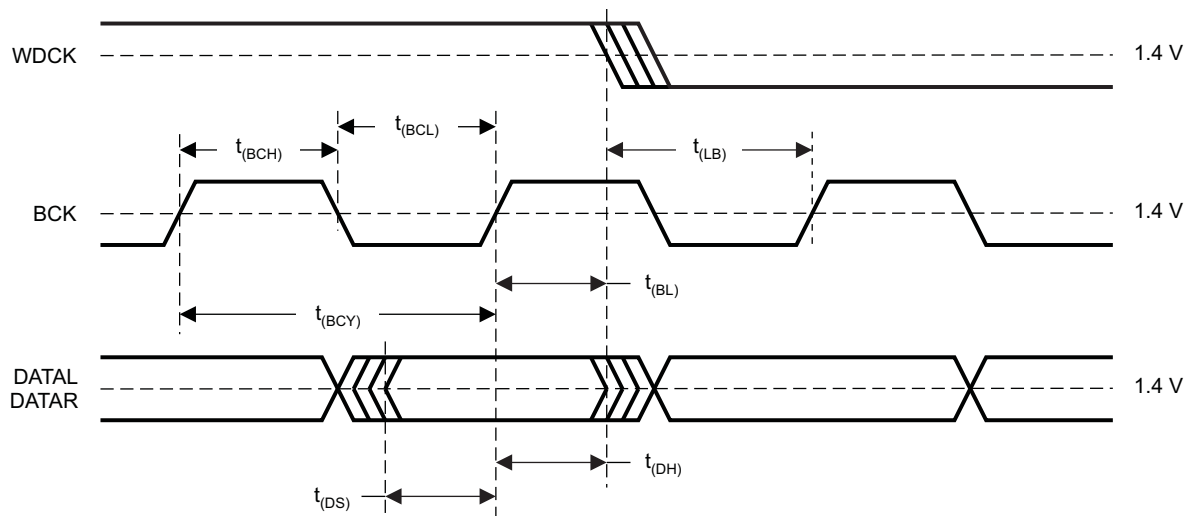

T0199-01

| PARAMETER | | MIN | MAX | UNIT |
|--------------|--------------------------------------|-----|-----|------|
| $t_{(BCY)}$ | BCK clock cycle time | 18 | | ns |
| $t_{w(BCL)}$ | BCK pulse duration, LOW | 7 | | ns |
| $t_{w(BCH)}$ | BCK pulse duration, HIGH | 7 | | ns |
| $t_{(BL)}$ | BCK rising edge to WDCK falling edge | 5 | | ns |
| $t_{(LB)}$ | WDCK falling edge to BCK rising edge | 5 | | ns |
| $t_{(DS)}$ | DATA setup time | 5 | | ns |
| $t_{(DH)}$ | DATA hold time | 5 | | ns |

Figure 43. Audio Interface Timing for External Digital Filter (Internal DF Bypass Mode) Application

Table 5. Register Mapping in the External Digital-Filter Mode

| REGISTER | B15 | B14 | B13 | B12 | B11 | B10 | B9 | B8 | B7 | B6 | B5 | B4 | B3 | B2 | B1 | B0 |
|----------|-----|-----|-----|-----|-----|-----|----|----|------------------|------|------|---------------------|------|------|--------------------|------|
| 16 | W/R | 0 | 0 | 1 | 0 | 0 | 0 | 0 | — ⁽¹⁾ | — | — | — | — | — | — | — |
| 17 | W/R | 0 | 0 | 1 | 0 | 0 | 0 | 1 | — | — | — | — | — | — | — | — |
| 18 | W/R | 0 | 0 | 1 | 0 | 0 | 1 | 0 | — | FMT2 | FMT1 | FMT0 | — | — | DME ⁽²⁾ | — |
| 19 | W/R | 0 | 0 | 1 | 0 | 0 | 1 | 1 | — | — | — | OPE | CLKD | CLKE | — | INZD |
| 20 | W/R | 0 | 0 | 1 | 0 | 1 | 0 | 0 | RSV | SRST | MRST | DFTH ⁽²⁾ | RSV | RSV | OS1 | OS0 |
| 21 | R | 0 | 0 | 1 | 0 | 1 | 0 | 1 | RSV | RSV | RSV | RSV | RSV | RSV | ZFGR | ZFGL |

(1) — = function disabled. No operation regardless of data setting.

(2) These bits are required for selection of the external digital-filter mode.

FMT[2:0] Audio Data Format Selection

These bits are available for read/write.

Default Value: 000

| FMT[2:0] Audio Data Format Select | |
|-----------------------------------|--|
| 000 | 16-bit, right-justified format (default) |
| 001 | 20-bit, right-justified format |
| 010 | 24-bit, right-justified format |
| Other | Reserved |

OS[1:0] Delta-Sigma Oversampling Rate Selection

These bits are available for read/write.

Default Value: 00

| OS[1:0] | Operation Speed Select |
|----------------|--------------------------------------|
| 00 | $8 \times f_{\text{WDCK}}$ (default) |
| 01 | Reserved |
| 10 | $16 \times f_{\text{WDCK}}$ |
| 11 | $4 \times f_{\text{WDCK}}$ |

The effective oversampling rate is determined by the oversampling performed by both the external digital filter and the delta-sigma modulator. For example, if the external digital filter is 8× oversampling, and the user selects OS[1:0] = 0, then the delta-sigma modulator oversamples by 8×, resulting in an effective oversampling rate of 64×.

ZFGx Zero-Detect Flag

where x = L or R, corresponding to the DAC output channel.

These bits are available only for read-back.

Default value: 00

| | |
|----------|---------------|
| ZFGx = 0 | Not ZERO |
| ZFGx = 1 | ZERO detected |

When the PCM1738 detects that audio input data is continuously zero for 1024 WDCKs, the ZFGx bit is set to 1 for the corresponding channel(s). Zero-detect flags are also available at ZEROL (pin 2) and ZEROR (pin 3).

APPLICATION FOR DSD FORMAT (DSD MODE) INTERFACE

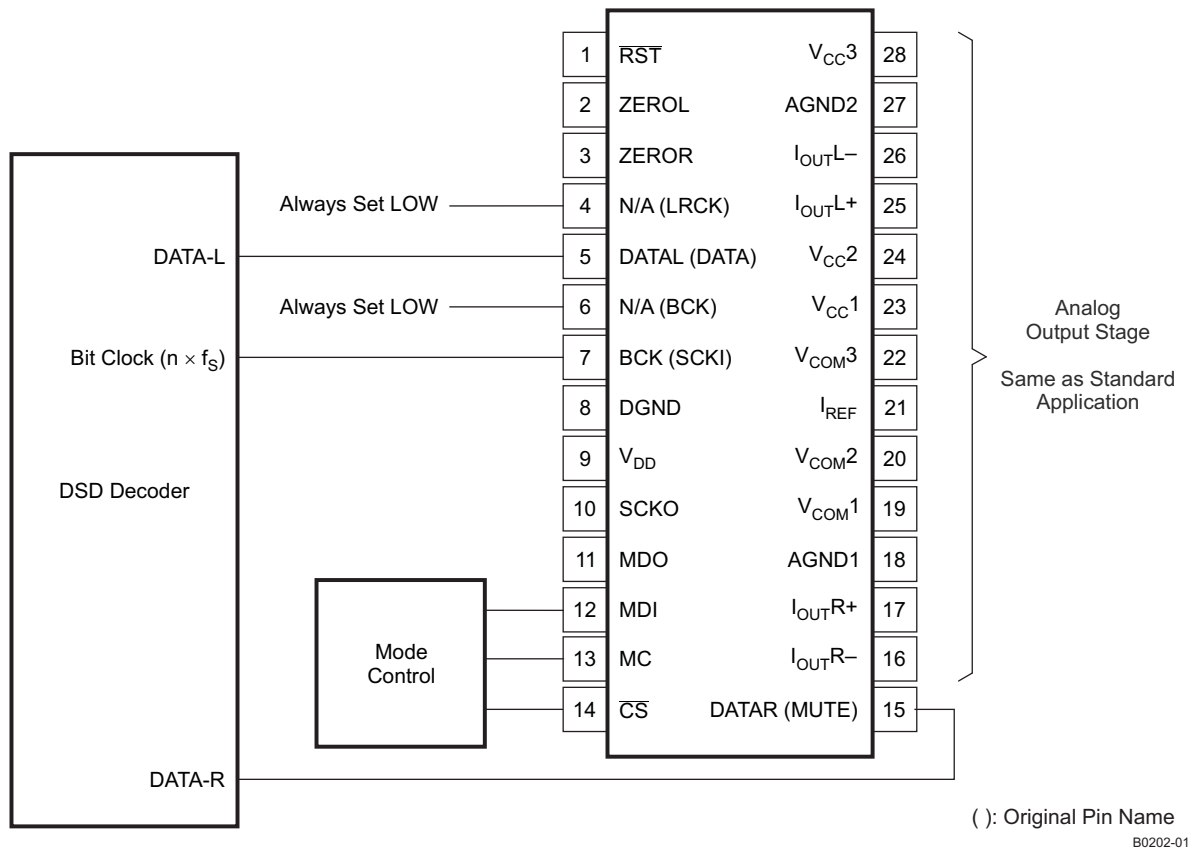

Figure 44. Connection Diagram for DSD Format Interface

FEATURES

This mode is used for interfacing directly to a DSD decoder, found in Super Audio CD (SACD) applications.

DSD mode provides a low-pass filtering function to convert the 1-bit oversampled data stream to the analog domain. The filtering is provided using an analog FIR filter structure. Four FIR responses are available and may be selected via the serial control interface. Refer to the [Typical Performance Curves](#) section of this data sheet for analog FIR plots. See [Figure 45](#) and [Figure 46](#) for timing and interface specification in DSD mode.

PIN ASSIGNMENT WHEN IN DSD-FORMAT INTERFACE

Several pins are redefined for DSD-mode operation. These include:

- DATA (pin 5)—DATAL, L-channel DSD data input
- MUTE (pin 15)—DATAR, R-channel DSD data input
- SCKI (pin 7)—bit clock (BCK) for DSD data
- LRCK (pin 4)—set LOW
- BCK (pin 6)—set LOW

Typical connection to a DSD decoder is shown in [Figure 44](#).

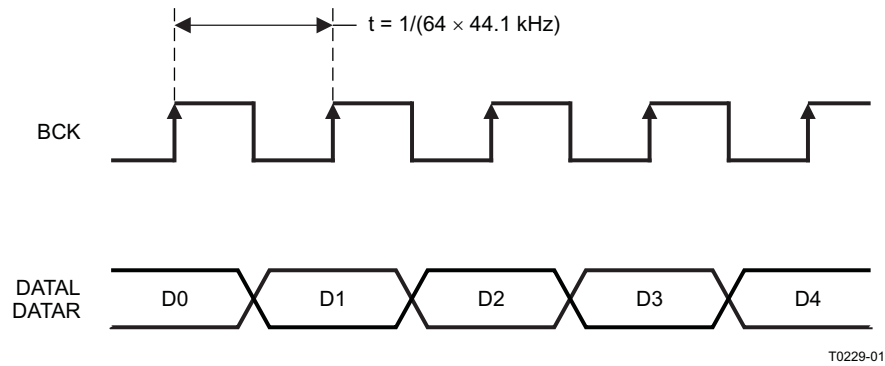
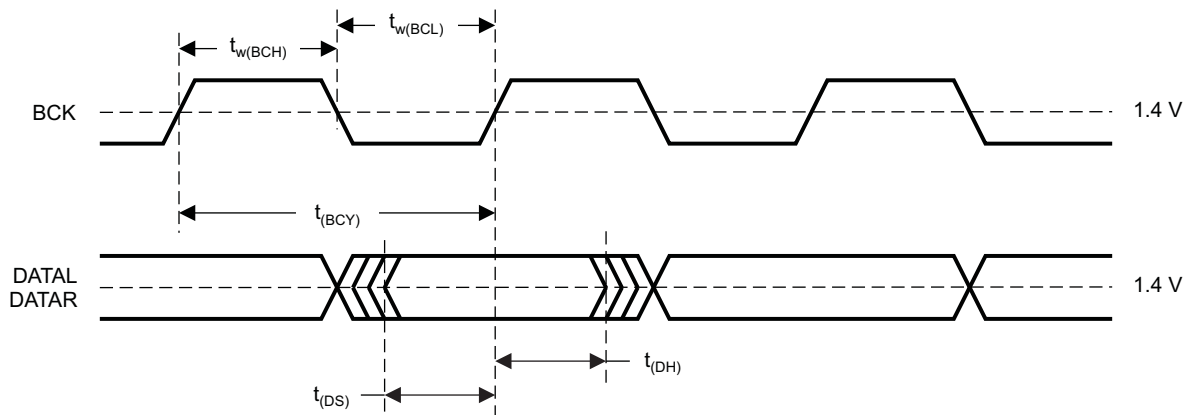

Figure 45. Normal Data Output Form From DSD Decoder



| PARAMETER | | MIN | MAX | UNIT |
|--------------|-------------------------|-------------------|-----|------|
| $t_{(BCY)}$ | BCK clock cycle time | 85 ⁽¹⁾ | | ns |
| $t_{w(BCH)}$ | BCK high-level time | 30 | | ns |
| $t_{w(BCL)}$ | BCK low-level time | 30 | | ns |
| $t_{(DS)}$ | DATAL, DATAR setup time | 10 | | ns |
| $t_{(DH)}$ | DATAL, DATAR hold time | 10 | | ns |

(1) $2.8224 \text{ MHz} \times 4$. ($2.8224 \text{ MHz} = 64 \times 44.1 \text{ kHz}$. This value is specified at the DSD sampling rate.)

Figure 46. Timing for DSD Audio Interface

DSD-MODE CONFIGURATION AND FUNCTION CONTROLS

Configuration for DSD interface mode:

- DFTH = 1 (register 20)
- DME = 1 (register 18)

Table 6 shows the register mapping available in DSD mode.

Table 6. Register Mapping in DSD Mode

| REGISTER | B15 | B14 | B13 | B12 | B11 | B10 | B9 | B8 | B7 | B6 | B5 | B4 | B3 | B2 | B1 | B0 |
|----------|-----|-----|-----|-----|-----|-----|----|----|------------------|------|------|---------------------|------|------|--------------------|-----|
| 16 | W/R | 0 | 0 | 1 | 0 | 0 | 0 | 0 | – ⁽¹⁾ | – | – | – | – | – | – | – |
| 17 | W/R | 0 | 0 | 1 | 0 | 0 | 0 | 1 | – | – | – | – | – | – | – | – |
| 18 | W/R | 0 | 0 | 1 | 0 | 0 | 1 | 0 | – | – | – | – | DMF1 | DMF0 | DME ⁽²⁾ | – |
| 19 | W/R | 0 | 0 | 1 | 0 | 0 | 1 | 1 | – | – | – | OPE | CLKD | CLKE | – | – |
| 20 | W/R | 0 | 0 | 1 | 0 | 1 | 0 | 0 | RSV | SRST | MRST | DFTH ⁽²⁾ | RSV | RSV | OS1 | OS0 |
| 21 | R | 0 | 0 | 1 | 0 | 1 | 0 | 1 | RSV | RSV | RSV | RSV | RSV | RSV | – | – |

(1) – = function disabled. No operation even if any data is set.

(2) These bits are required for selection of the DSD mode.

DMF[1:0] Analog FIR Performance Selection

These bits are available for read/write.

Default value: 00

DMF[1:0] Analog FIR Performance Select

| | |
|----|------------------------|
| 00 | DSD filter 1 (default) |
| 01 | DSD filter 2 |
| 10 | DSD filter 3 |
| 11 | DSD filter 4 |

Plots for the four analog FIR filter responses are shown in the [Typical Performance Curves](#) of this data sheet.

OS[1:0] Analog FIR Operation Speed Selection

These bits are available for read/write.

Default value: 00

OS[1:0] Operation Speed Select

| | |
|----|----------------------|
| 00 | f_{SCKI} (default) |
| 01 | Reserved |
| 10 | Reserved |
| 11 | $f_{SCKI}/2$ |

The OS bit in the DSD mode is used to select the operating rate of the analog FIR.

REQUIREMENTS FOR SYSTEM CLOCK

The bit clock (BCK) for DSD mode is required at pin 7 of the PCM1738. The frequency of the bit clock may be N times the sampling frequency. Generally, N is 64 in DSD applications.

The interface timing among the bit clock, DATAL, and DATAR is required to meet the same setup and hold-time specifications as shown for the PCM audio-format interface in [Figure 36](#).

APPLICATION FOR MONAURAL-MODE OPERATION

Single-channel signals within stereo-audio data input are output to both I_{OUTL} and I_{OUTR} as differential outputs. Selection of channels to output is available with the CHSL bit in register 20. Applications, such as monaural operation, are useful for high-end audio applications to provide over 120 dB for dynamic range. A typical MONO mode application is shown in [Figure 47](#).

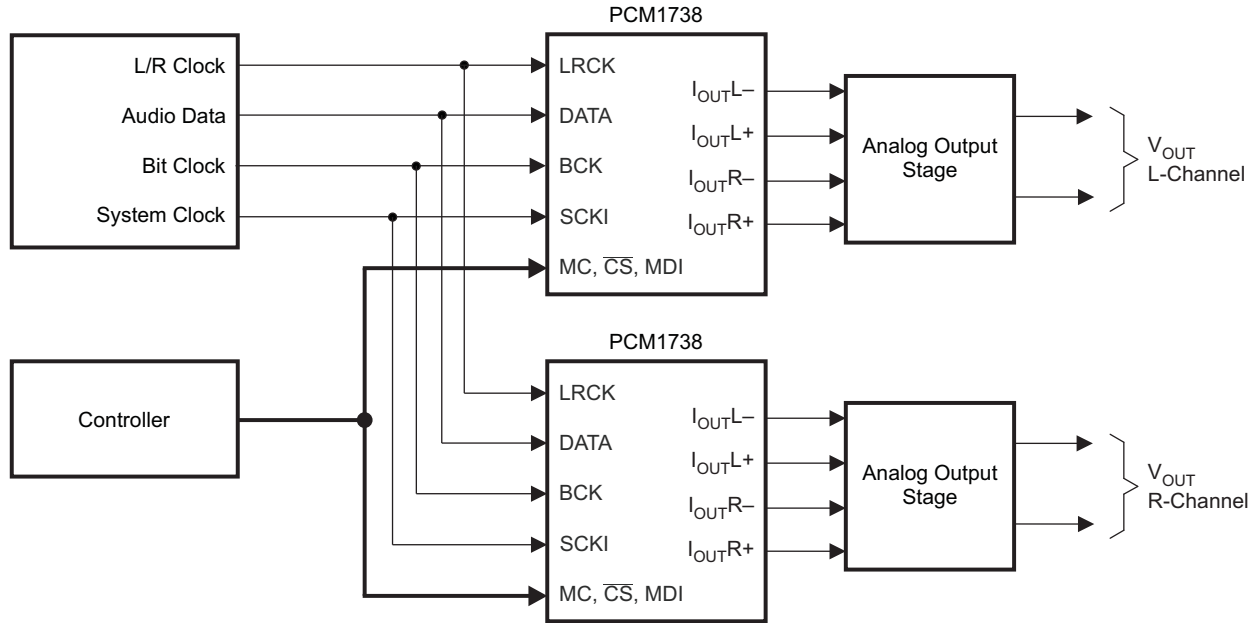

B0203-01

Figure 47. Connection Diagram for Monaural-Mode Interface

THEORY OF OPERATION

ADVANCED SEGMENT DAC

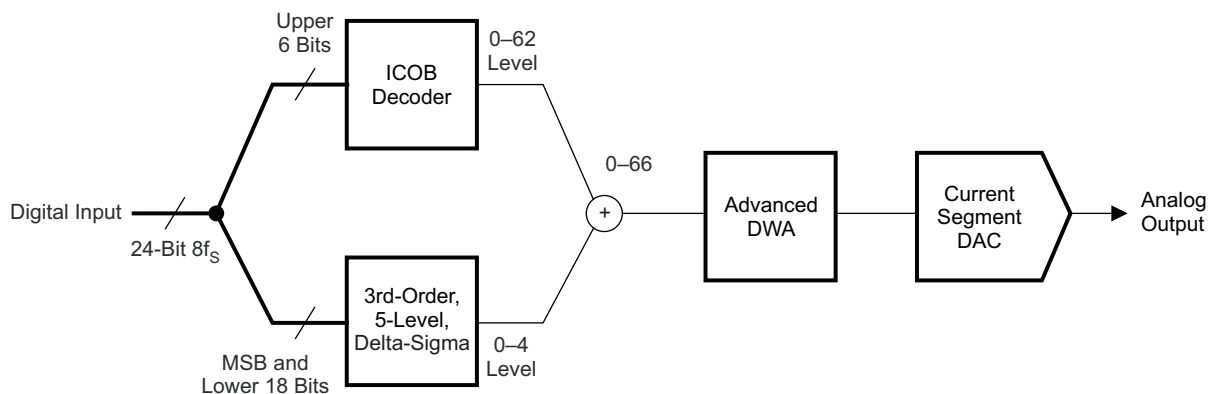

B0204-01

Figure 48. Architecture of Advanced Segment DAC

The PCM1738 uses the newly developed advanced segment DAC architecture to achieve excellent dynamic performance and improved tolerance to clock jitter. The PCM1738 provides balanced current outputs, allowing the user to optimize analog performance externally. The structure of the advanced segment DAC architecture is shown in [Figure 48](#).

Digital input data from the digital interpolation filter is split into six upper bits and 18 lower bits. The upper six bits are converted to inverted complementary offset binary (ICOB) code. The lower 18 bits associated with the MSB are processed by five-level, third-order, delta-sigma modulators operated at $64 f_s$ by default conditions. The level of the modulator is equivalent to one LSB of the ICOB code converter (decoder). The data groups processed in the ICOB converter and the third-order delta-sigma modulator are summed together to create up to 66 levels of digital code that is then processed by data-weighted averaging (DWA) to reduce noise produced by element mismatch. The output data from the DWA block is then converted to an analog output using a differential current segment DAC.

CONSIDERATIONS FOR APPLICATIONS CIRCUITS

PCB LAYOUT GUIDELINES

A typical PCB floor plan for the PCM1738 is shown in [Figure 49](#). A ground plane is recommended, with the analog and digital sections being isolated from one another using a split or cut in the circuit board. The PCM1738 should be oriented with the digital I/O pins facing the ground plane split/cut to allow for short, direct connections to the digital audio interface and control signals originating from the digital section of the board.

Separate power supplies are recommended for the digital and analog sections of the board. This prevents the switching noise present on the digital supply from contaminating the analog power supply and degrading the dynamic performance of the DACs. In cases where a common 5-V supply must be used for the analog and digital sections, an inductance (RF choke, ferrite bead) should be placed between the analog and digital 5-V supply connections to avoid coupling of the digital switching noise into the analog circuitry. [Figure 50](#) shows the recommended approach for single supply applications.

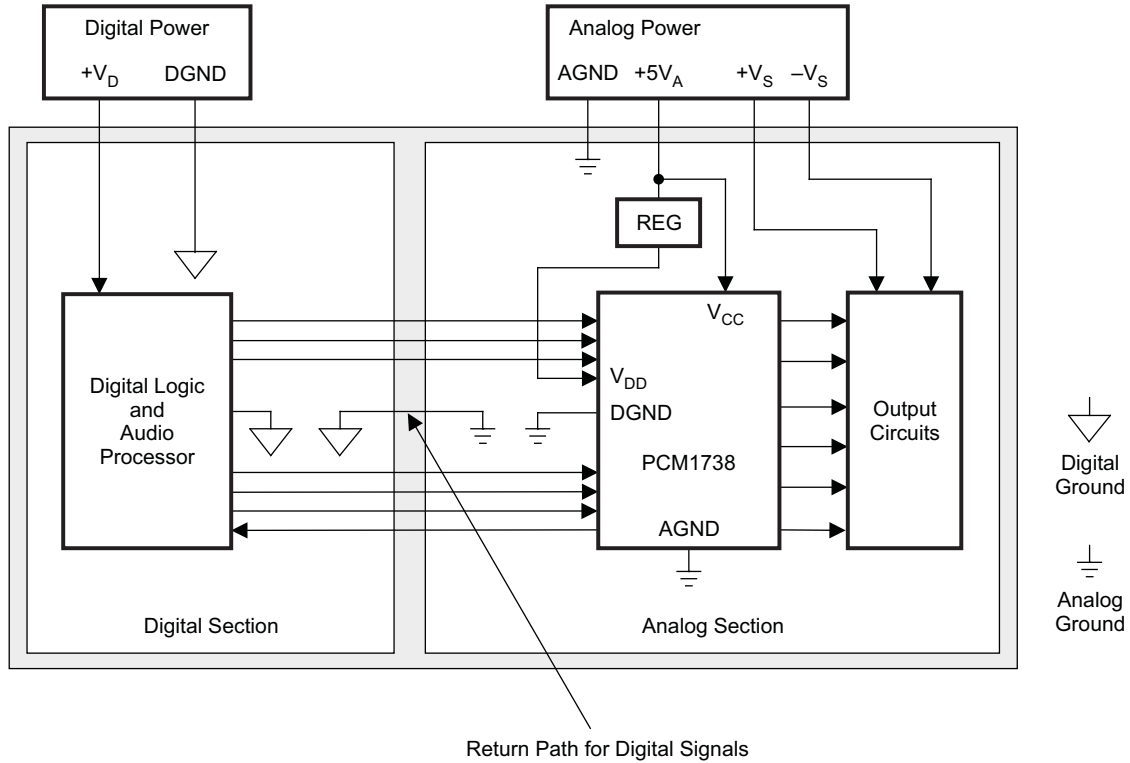

B0031-07

Figure 49. Recommended PCB Layout

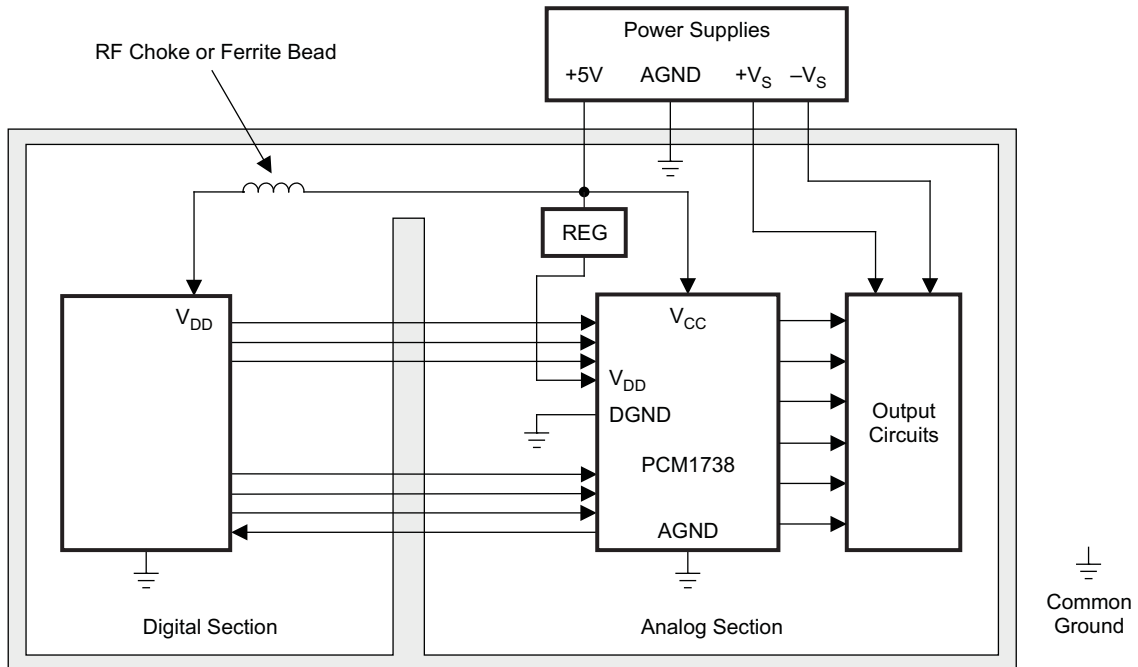

B0032-07

Figure 50. Single-Supply PCB Layout

BYPASS AND DECOUPLING CAPACITOR REQUIREMENTS

Various sized decoupling capacitors can be used, with no special tolerances being required. All capacitors should be located as close as physically possible to the power supply and reference pins of the PCM1738 to reduce noise pickup from surrounding circuitry. Aluminum electrolytic capacitors that are designed for hi-fi audio applications are recommended for larger values, while metal-film or monolithic ceramic capacitors are recommended for smaller values.

I/V SECTION

Using the circuit shown in [Figure 40](#) for I/V conversion achieves data-sheet performance. To obtain 0.0005% THD+N, 117-dB signal-to-noise ratio audio performance, THD+N and input noise performance, an operational amplifier IC must be considered. Input noise of the operational amplifier directly affects the output noise level of the application.

All components of the I/V section should be located physically close to the PCM1738 current outputs. All connections should be made as short as possible to eliminate pickup of radiated noise.

POST LOW-PASS FILTER DESIGN

The out-of-band noise level and sampling spectrum level are much lower than typical delta-sigma type DACs, due to the combination of a high-performance digital filter and the advanced segment DAC architecture. The use of a second- or third-order filter is recommended for the post low-pass filter (see [Figure 40](#) for a second-order filter) following the I/V conversion stage. The cutoff frequency of the post LPF is dependent upon the application, given the variety of sampling rates supported by the CD-DA ($f_s = 44.1$ kHz), DVD-M ($f_s = 96$ kHz), DVD-A ($f_s = 192$ kHz), and SACD ($f_s = 44.1$ kHz) systems.

PACKAGING INFORMATION

| Orderable Device | Status (1) | Package Type | Package Drawing | Pins | Package Qty | Eco Plan (2) | Lead/Ball Finish (6) | MSL Peak Temp (3) | Op Temp (°C) | Device Marking (4/5) | Samples |
|------------------|---------------|--------------|-----------------|------|-------------|-------------------------|-------------------------|----------------------|--------------|-------------------------|---------|
| PCM1738E | NRND | SSOP | DB | 28 | 47 | Green (RoHS & no Sb/Br) | CU NIPDAU | Level-1-260C-UNLIM | | PCM1738E | |
| PCM1738E/2K | NRND | SSOP | DB | 28 | 2000 | Green (RoHS & no Sb/Br) | CU NIPDAU | Level-1-260C-UNLIM | | PCM1738E | |

(1) The marketing status values are defined as follows:

ACTIVE: Product device recommended for new designs.

LIFEBUY: TI has announced that the device will be discontinued, and a lifetime-buy period is in effect.

NRND: Not recommended for new designs. Device is in production to support existing customers, but TI does not recommend using this part in a new design.

PREVIEW: Device has been announced but is not in production. Samples may or may not be available.

OBSOLETE: TI has discontinued the production of the device.

(2) **RoHS:** TI defines "RoHS" to mean semiconductor products that are compliant with the current EU RoHS requirements for all 10 RoHS substances, including the requirement that RoHS substance do not exceed 0.1% by weight in homogeneous materials. Where designed to be soldered at high temperatures, "RoHS" products are suitable for use in specified lead-free processes. TI may reference these types of products as "Pb-Free".

RoHS Exempt: TI defines "RoHS Exempt" to mean products that contain lead but are compliant with EU RoHS pursuant to a specific EU RoHS exemption.

Green: TI defines "Green" to mean the content of Chlorine (Cl) and Bromine (Br) based flame retardants meet JS709B low halogen requirements of <=1000ppm threshold. Antimony trioxide based flame retardants must also meet the <=1000ppm threshold requirement.

(3) MSL, Peak Temp. - The Moisture Sensitivity Level rating according to the JEDEC industry standard classifications, and peak solder temperature.

(4) There may be additional marking, which relates to the logo, the lot trace code information, or the environmental category on the device.

(5) Multiple Device Markings will be inside parentheses. Only one Device Marking contained in parentheses and separated by a "~" will appear on a device. If a line is indented then it is a continuation of the previous line and the two combined represent the entire Device Marking for that device.

(6) Lead/Ball Finish - Orderable Devices may have multiple material finish options. Finish options are separated by a vertical ruled line. Lead/Ball Finish values may wrap to two lines if the finish value exceeds the maximum column width.

Important Information and Disclaimer:The information provided on this page represents TI's knowledge and belief as of the date that it is provided. TI bases its knowledge and belief on information provided by third parties, and makes no representation or warranty as to the accuracy of such information. Efforts are underway to better integrate information from third parties. TI has taken and continues to take reasonable steps to provide representative and accurate information but may not have conducted destructive testing or chemical analysis on incoming materials and chemicals. TI and TI suppliers consider certain information to be proprietary, and thus CAS numbers and other limited information may not be available for release.

In no event shall TI's liability arising out of such information exceed the total purchase price of the TI part(s) at issue in this document sold by TI to Customer on an annual basis.

TAPE AND REEL INFORMATION

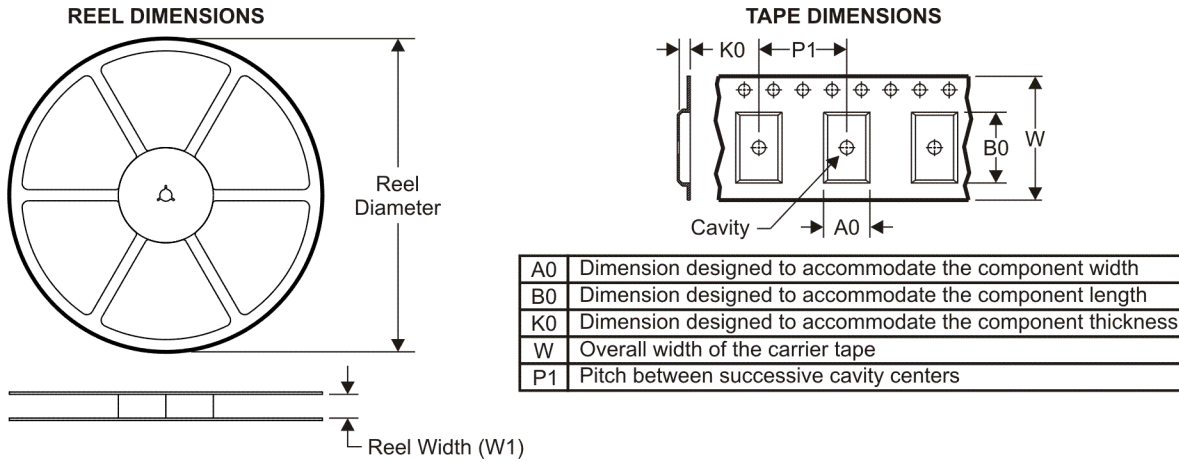

QUADRANT ASSIGNMENTS FOR PIN 1 ORIENTATION IN TAPE

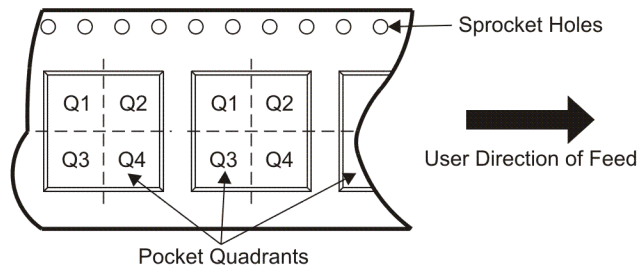

*All dimensions are nominal

| Device | Package Type | Package Drawing | Pins | SPQ | Reel Diameter (mm) | Reel Width W1 (mm) | A0 (mm) | B0 (mm) | K0 (mm) | P1 (mm) | W (mm) | Pin1 Quadrant |
|-------------|--------------|-----------------|------|------|--------------------|--------------------|---------|---------|---------|---------|--------|---------------|
| PCM1738E/2K | SSOP | DB | 28 | 2000 | 330.0 | 17.4 | 8.5 | 10.8 | 2.4 | 12.0 | 16.0 | Q1 |

TAPE AND REEL BOX DIMENSIONS

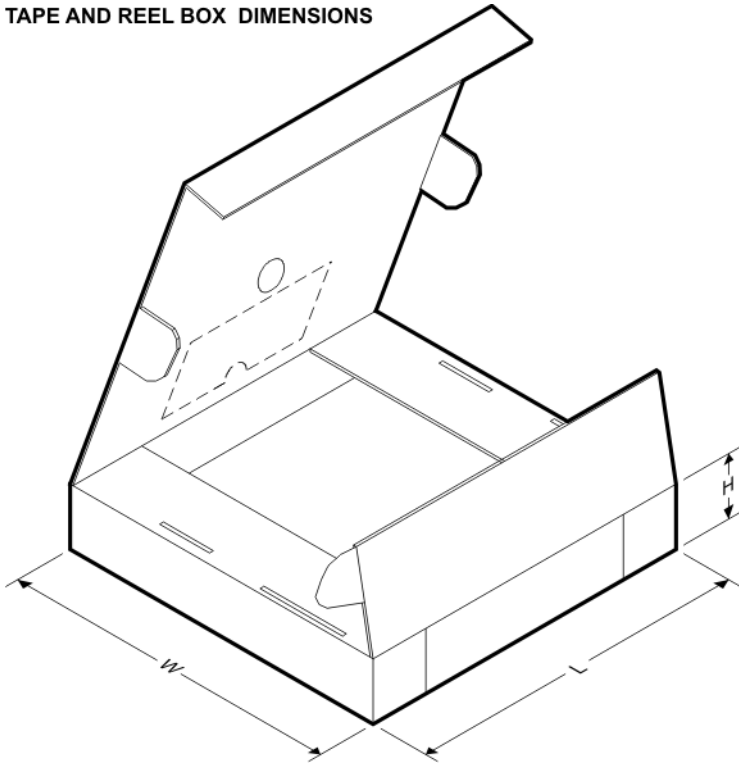

*All dimensions are nominal

| Device | Package Type | Package Drawing | Pins | SPQ | Length (mm) | Width (mm) | Height (mm) |
|-------------|--------------|-----------------|------|------|-------------|------------|-------------|
| PCM1738E/2K | SSOP | DB | 28 | 2000 | 336.6 | 336.6 | 28.6 |

IMPORTANT NOTICE

Texas Instruments Incorporated (TI) reserves the right to make corrections, enhancements, improvements and other changes to its semiconductor products and services per JESD46, latest issue, and to discontinue any product or service per JESD48, latest issue. Buyers should obtain the latest relevant information before placing orders and should verify that such information is current and complete.

TI's published terms of sale for semiconductor products (<http://www.ti.com/sc/docs/stdterms.htm>) apply to the sale of packaged integrated circuit products that TI has qualified and released to market. Additional terms may apply to the use or sale of other types of TI products and services.

Reproduction of significant portions of TI information in TI data sheets is permissible only if reproduction is without alteration and is accompanied by all associated warranties, conditions, limitations, and notices. TI is not responsible or liable for such reproduced documentation. Information of third parties may be subject to additional restrictions. Resale of TI products or services with statements different from or beyond the parameters stated by TI for that product or service voids all express and any implied warranties for the associated TI product or service and is an unfair and deceptive business practice. TI is not responsible or liable for any such statements.

Buyers and others who are developing systems that incorporate TI products (collectively, "Designers") understand and agree that Designers remain responsible for using their independent analysis, evaluation and judgment in designing their applications and that Designers have full and exclusive responsibility to assure the safety of Designers' applications and compliance of their applications (and of all TI products used in or for Designers' applications) with all applicable regulations, laws and other applicable requirements. Designer represents that, with respect to their applications, Designer has all the necessary expertise to create and implement safeguards that (1) anticipate dangerous consequences of failures, (2) monitor failures and their consequences, and (3) lessen the likelihood of failures that might cause harm and take appropriate actions. Designer agrees that prior to using or distributing any applications that include TI products, Designer will thoroughly test such applications and the functionality of such TI products as used in such applications.

TI's provision of technical, application or other design advice, quality characterization, reliability data or other services or information, including, but not limited to, reference designs and materials relating to evaluation modules, (collectively, "TI Resources") are intended to assist designers who are developing applications that incorporate TI products; by downloading, accessing or using TI Resources in any way, Designer (individually or, if Designer is acting on behalf of a company, Designer's company) agrees to use any particular TI Resource solely for this purpose and subject to the terms of this Notice.

TI's provision of TI Resources does not expand or otherwise alter TI's applicable published warranties or warranty disclaimers for TI products, and no additional obligations or liabilities arise from TI providing such TI Resources. TI reserves the right to make corrections, enhancements, improvements and other changes to its TI Resources. TI has not conducted any testing other than that specifically described in the published documentation for a particular TI Resource.

Designer is authorized to use, copy and modify any individual TI Resource only in connection with the development of applications that include the TI product(s) identified in such TI Resource. NO OTHER LICENSE, EXPRESS OR IMPLIED, BY ESTOPPEL OR OTHERWISE TO ANY OTHER TI INTELLECTUAL PROPERTY RIGHT, AND NO LICENSE TO ANY TECHNOLOGY OR INTELLECTUAL PROPERTY RIGHT OF TI OR ANY THIRD PARTY IS GRANTED HEREIN, including but not limited to any patent right, copyright, mask work right, or other intellectual property right relating to any combination, machine, or process in which TI products or services are used. Information regarding or referencing third-party products or services does not constitute a license to use such products or services, or a warranty or endorsement thereof. Use of TI Resources may require a license from a third party under the patents or other intellectual property of the third party, or a license from TI under the patents or other intellectual property of TI.

TI RESOURCES ARE PROVIDED "AS IS" AND WITH ALL FAULTS. TI DISCLAIMS ALL OTHER WARRANTIES OR REPRESENTATIONS, EXPRESS OR IMPLIED, REGARDING RESOURCES OR USE THEREOF, INCLUDING BUT NOT LIMITED TO ACCURACY OR COMPLETENESS, TITLE, ANY EPIDEMIC FAILURE WARRANTY AND ANY IMPLIED WARRANTIES OF MERCHANTABILITY, FITNESS FOR A PARTICULAR PURPOSE, AND NON-INFRINGEMENT OF ANY THIRD PARTY INTELLECTUAL PROPERTY RIGHTS. TI SHALL NOT BE LIABLE FOR AND SHALL NOT DEFEND OR INDEMNIFY DESIGNER AGAINST ANY CLAIM, INCLUDING BUT NOT LIMITED TO ANY INFRINGEMENT CLAIM THAT RELATES TO OR IS BASED ON ANY COMBINATION OF PRODUCTS EVEN IF DESCRIBED IN TI RESOURCES OR OTHERWISE. IN NO EVENT SHALL TI BE LIABLE FOR ANY ACTUAL, DIRECT, SPECIAL, COLLATERAL, INDIRECT, PUNITIVE, INCIDENTAL, CONSEQUENTIAL OR EXEMPLARY DAMAGES IN CONNECTION WITH OR ARISING OUT OF TI RESOURCES OR USE THEREOF, AND REGARDLESS OF WHETHER TI HAS BEEN ADVISED OF THE POSSIBILITY OF SUCH DAMAGES.

Unless TI has explicitly designated an individual product as meeting the requirements of a particular industry standard (e.g., ISO/TS 16949 and ISO 26262), TI is not responsible for any failure to meet such industry standard requirements.

Where TI specifically promotes products as facilitating functional safety or as compliant with industry functional safety standards, such products are intended to help enable customers to design and create their own applications that meet applicable functional safety standards and requirements. Using products in an application does not by itself establish any safety features in the application. Designers must ensure compliance with safety-related requirements and standards applicable to their applications. Designer may not use any TI products in life-critical medical equipment unless authorized officers of the parties have executed a special contract specifically governing such use. Life-critical medical equipment is medical equipment where failure of such equipment would cause serious bodily injury or death (e.g., life support, pacemakers, defibrillators, heart pumps, neurostimulators, and implantables). Such equipment includes, without limitation, all medical devices identified by the U.S. Food and Drug Administration as Class III devices and equivalent classifications outside the U.S.

TI may expressly designate certain products as completing a particular qualification (e.g., Q100, Military Grade, or Enhanced Product). Designers agree that it has the necessary expertise to select the product with the appropriate qualification designation for their applications and that proper product selection is at Designers' own risk. Designers are solely responsible for compliance with all legal and regulatory requirements in connection with such selection.

Designer will fully indemnify TI and its representatives against any damages, costs, losses, and/or liabilities arising out of Designer's non-compliance with the terms and provisions of this Notice.

Looking for pricing, stock, or lifecycle information?

Click below to explore more details on WIN SOURCE:

 [View PCM1738E](#) on WIN SOURCE

 [Texas Instruments](#) Information

Optimize Your Supply Chain with WIN SOURCE Solutions

-  Global Sourcing Solution
-  Obsolete Management
-  Cost Control Management
-  Shortage Management
-  Alternative Solution
-  Excess Inventory Management