



PCF8578

LCD row/column driver for dot matrix graphic displays

Rev. 06 — 5 May 2009

Product data sheet

1. General description

The PCF8578 is a low power CMOS¹ LCD row and column driver, designed to drive dot matrix graphic displays at multiplex rates of 1:8, 1:16, 1:24 or 1:32. The device has 40 outputs, of which 24 are programmable and configurable for the following ratios of rows/columns: $\frac{32}{8}$, $\frac{24}{16}$, $\frac{16}{24}$ or $\frac{8}{32}$. The PCF8578 can function as a stand-alone LCD controller and driver for use in small systems. For larger systems it can be used in conjunction with up to 32 PCF8579s for which it has been optimized. Together these two devices form a general purpose LCD dot matrix driver chip set, capable of driving displays of up to 40960 dots. The PCF8578 is compatible with most microcontrollers and communicates via a two-line bidirectional bus (I²C-bus). Communication overhead is minimized by a display RAM with auto-incremented addressing and display bank switching.

2. Features

- Single chip LCD controller and driver
- Stand-alone or may be used with up to 32 PCF8579s (40960 dots possible)
- 40 driver outputs, configurable for several ratios of rows/columns: $\frac{32}{8}$, $\frac{24}{16}$, $\frac{16}{24}$ or $\frac{8}{32}$
- Selectable multiplex rates: 1:8, 1:16, 1:24 or 1:32
- Externally selectable bias configuration, 5 or 6 levels
- 1280-bit RAM for display data storage and scratch pad
- Display memory bank switching
- Auto-incremented data loading across hardware subaddress boundaries (with PCF8579)
- Provides display synchronization for PCF8579
- On-chip oscillator, requires only 1 external resistor
- Power-On Reset (POR) blanks display
- Logic voltage supply range 2.5 V to 6 V
- Maximum LCD supply voltage 9 V
- Low power consumption
- I²C-bus interface
- Compatible with most microcontrollers
- Optimized pinning for single plane wiring in multiple device applications (with PCF8579)
- Space saving 56-lead small outline package and 64 pin quad flat pack

1. The definition of the abbreviations and acronyms used in this data sheet can be found in [Section 15](#).

3. Applications

- Automotive information systems
- Telecommunication systems
- Point-of-sale terminals
- Industrial computer terminals
- Instrumentation

4. Ordering information

Table 1. Ordering information

Type number	Package		
	Name	Description	Version
PCF8578T/1	VSO56	plastic very small outline package; 56 leads	SOT190-1
PCF8578H/1	LQFP64	plastic low profile quad flat package; 64 leads; body 10 × 10 × 1.4 mm ^[1]	SOT314-2
PCF8578HT/1	TQFP64	plastic thin quad flat package; 64 leads; body 10 × 10 × 1.0 mm	SOT357-1

[1] Should not be used for new designs.

5. Marking

Table 2. Marking codes

Type number	Marking code
PCF8578T/1	PCF8578T
PCF8578H/1	PCF8578H
PCF8578HT/1	PCF8578HT

6. Block diagram

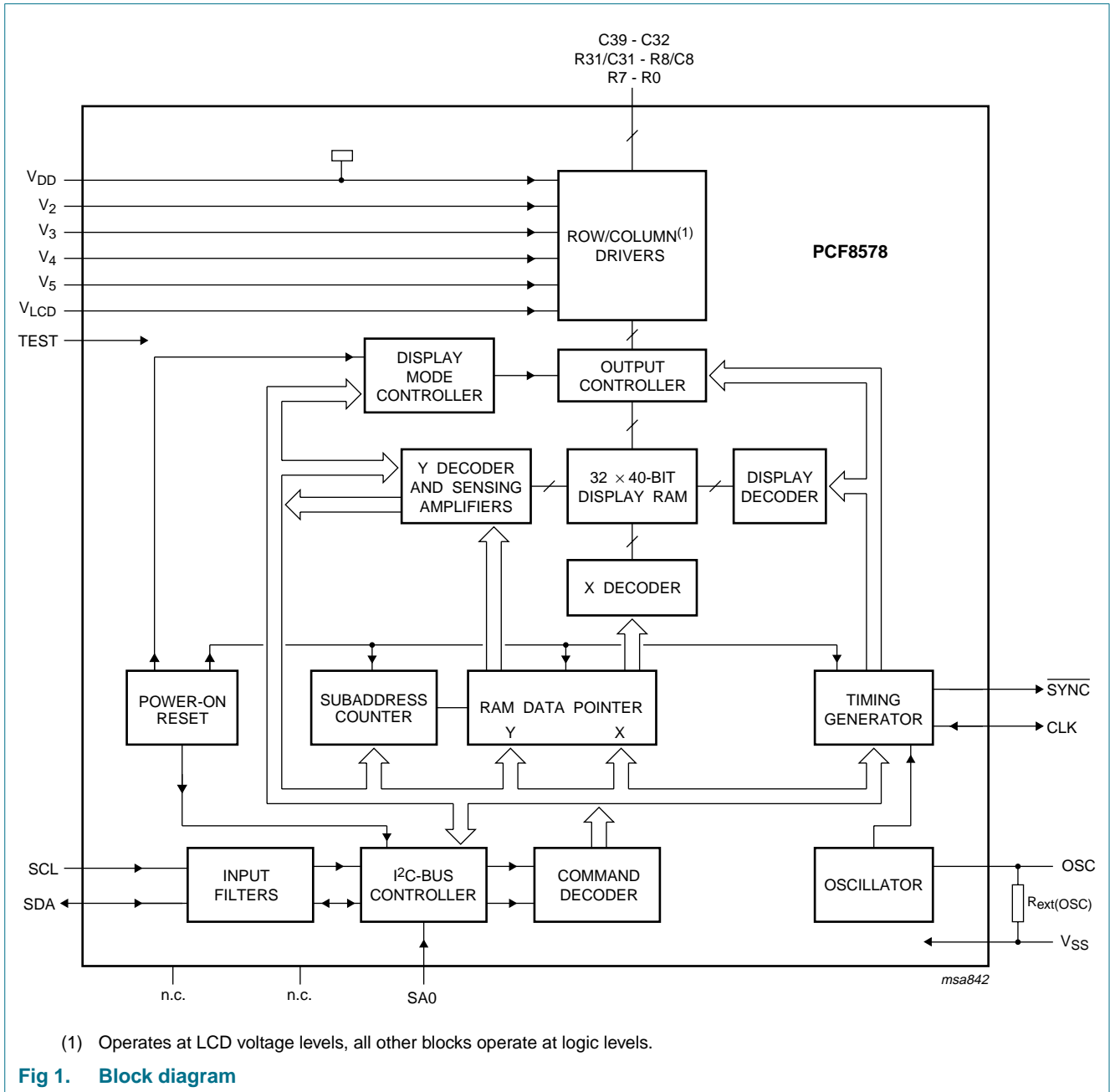

7. Pinning information

7.1 Pinning

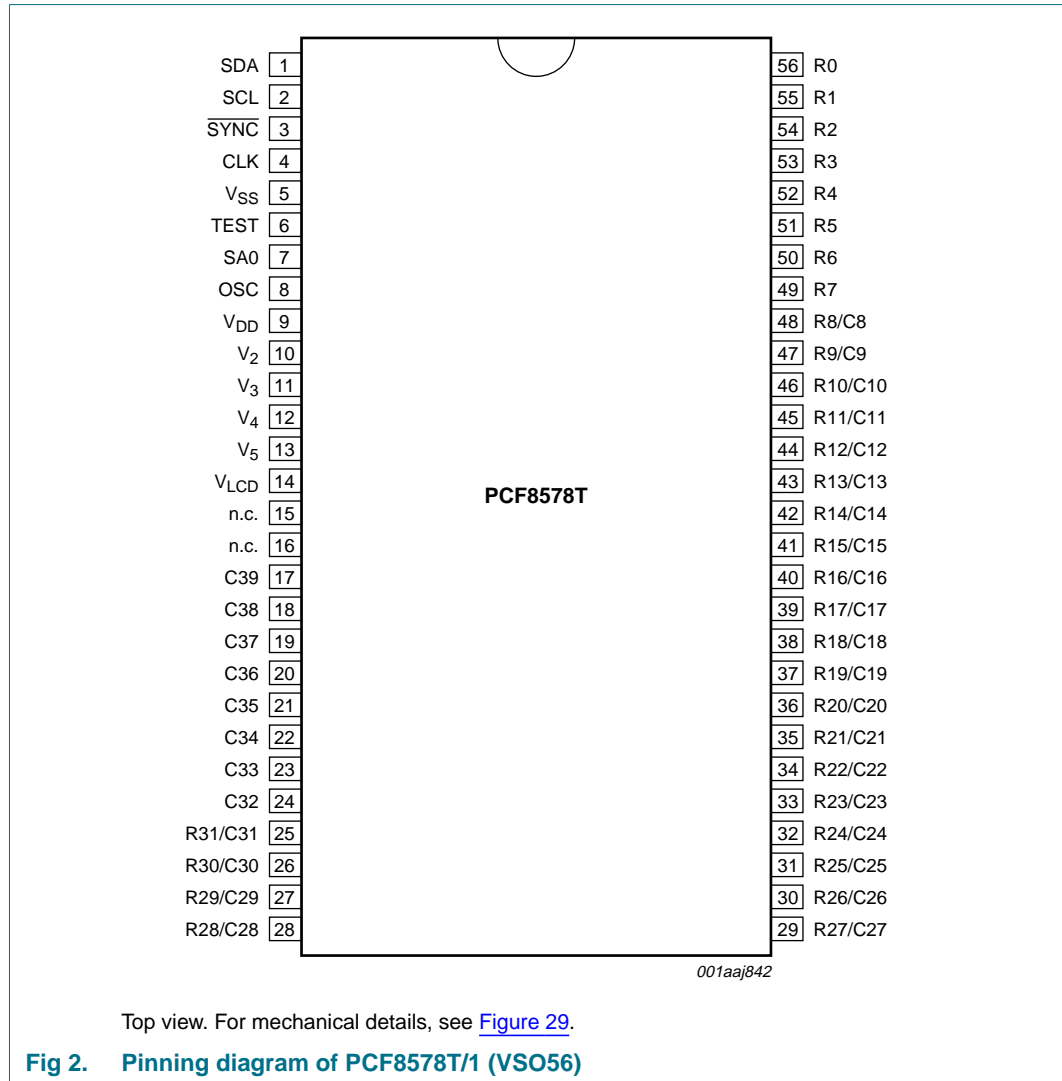

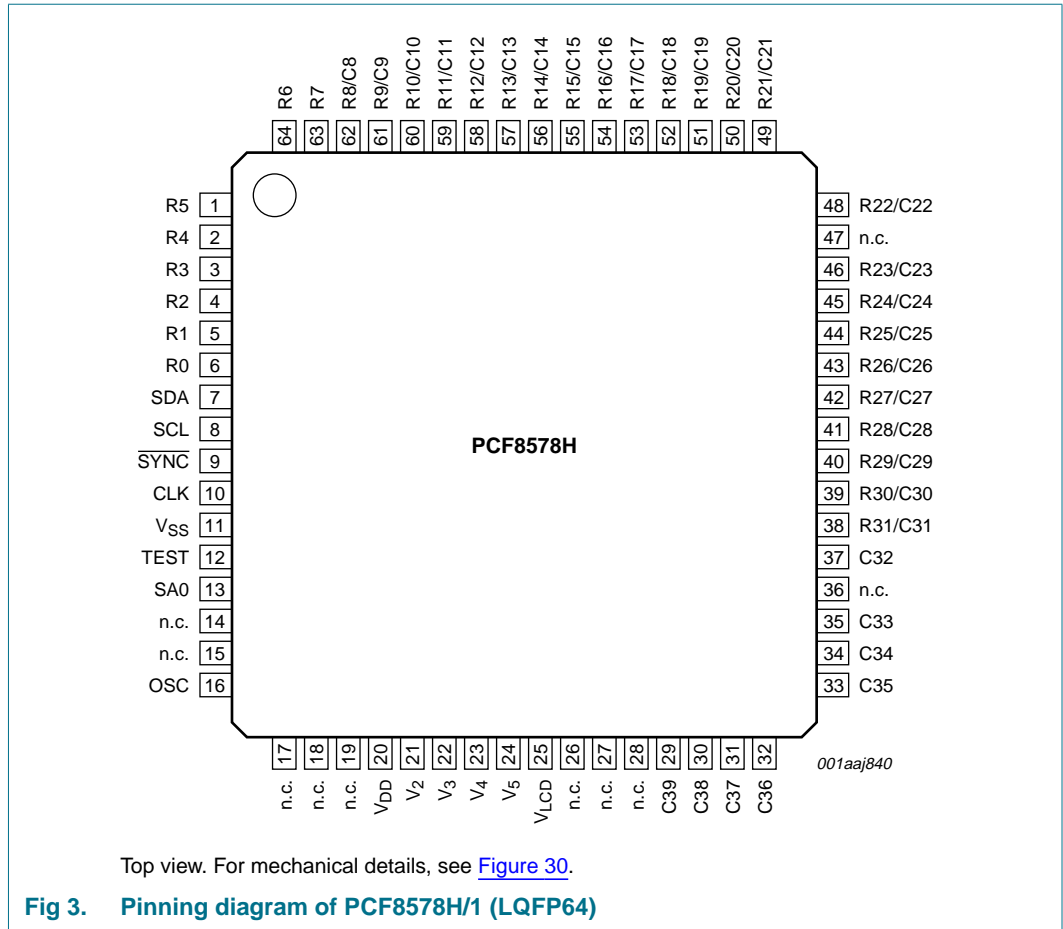

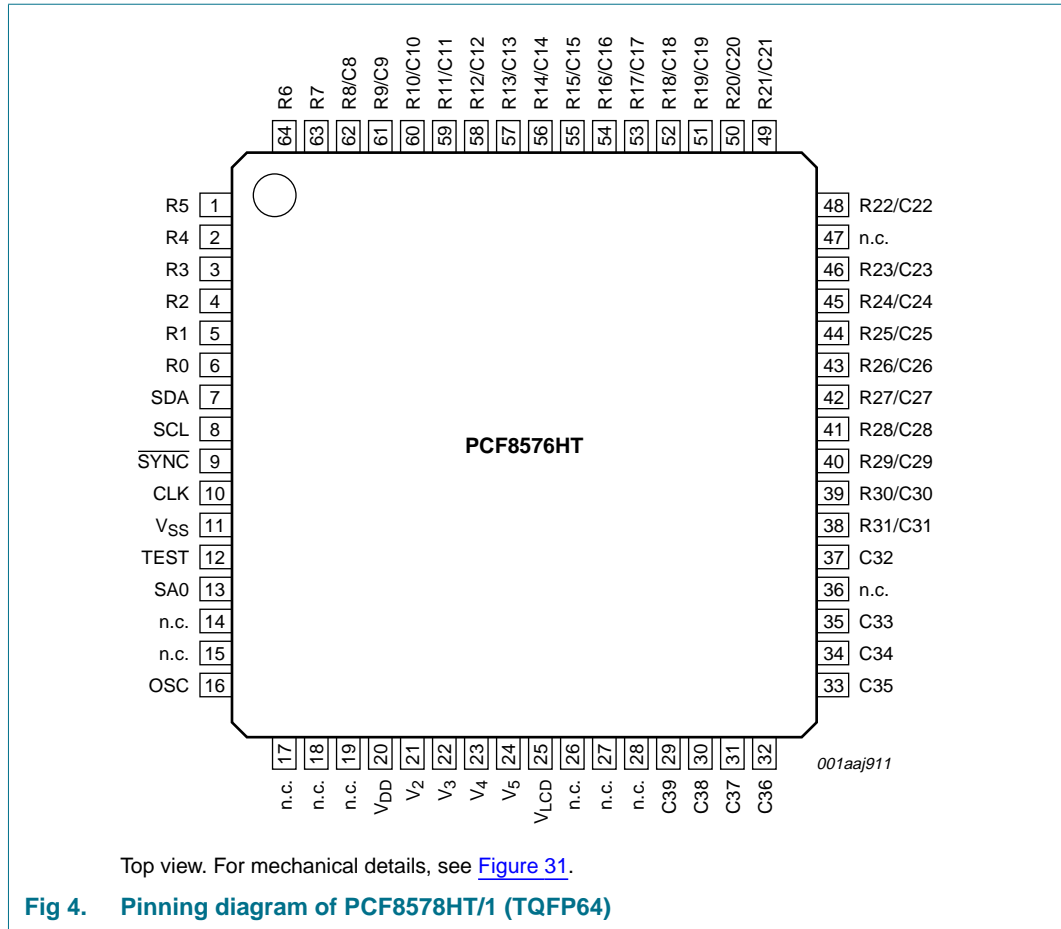

7.2 Pin description

Table 3. Pin description

Symbol	Pin		Description
	VSO56	LQFP64, TQFP64	
SDA	1	7	I ² C-bus serial data input/output
SCL	2	8	I ² C-bus serial clock input
$\overline{\text{SYNC}}$	3	9	cascade synchronization output
CLK	4	10	external clock input/output
V _{SS}	5	11	ground
TEST ^[1]	6	12	test pin
SA0	7	13	I ² C-bus slave address input (bit 0)
OSC	8	16	oscillator input
V _{DD}	9	20	supply voltage
V ₂ to V ₅	10 to 13	21 to 24	LCD bias voltage inputs
V _{LCD}	14	25	LCD supply voltage
n.c.	15, 16	14, 15, 17 to 19, 26 to 28, 36, 47	not connected
C39 to C32	17 to 24	29 to 35, 37	LCD column driver outputs
R31/C31 to R8/C8	25 to 48	38 to 46, 48 to 62	LCD row and column driver outputs
R7 to R0	49 to 56	63, 64, 1 to 6	LCD row driver outputs

[1] The TEST pin must be connected to V_{SS}.

8. Functional description

8.1 Display configurations

The PCF8578 row and column driver is designed for use in one of three ways:

- Stand-alone row and column driver for small displays (mixed mode)
- Row and column driver with cascaded PCF8579s (mixed mode)
- Row driver with cascaded PCF8579s (mixed mode and row mode)

Table 4. Possible display configurations

Application	Multiplex rate	Mixed mode		Row mode		Typical applications
		Rows	Columns	Rows	Columns	
stand alone	1:8	8	32	-	-	small digital or alphanumeric displays
	1:16	16	24	-	-	
	1:24	24	16	-	-	
	1:32	32	8	-	-	
with PCF8579	1:8	8 ^[1]	632 ^[1]	8 × 4 ^[2]	640 ^[2]	alphanumeric displays and dot matrix graphic displays
	1:16	16 ^[1]	624 ^[1]	16 × 2 ^[2]	640 ^[2]	
	1:24	24 ^[1]	616 ^[1]	24 ^[2]	640 ^[2]	
	1:32	32 ^[1]	608 ^[1]	32 ^[2]	640 ^[2]	

[1] Using 15 PCF8579s.

[2] Using 16 PCF8579s.

In mixed mode, the device functions as both a row and column driver. It can be used in small stand-alone applications, or for larger displays with up to 15 PCF8579s (31 PCF8579s when two slave addresses are used). See [Table 4](#) for common display configurations.

In row mode, the device functions as a row driver with up to 32 row outputs and provides the clock and synchronization signals for the PCF8579. Up to 16 PCF8579s can normally be cascaded (32 when two slave addresses are used).

Timing signals are derived from the on-chip oscillator, whose frequency is determined by the value of the resistor connected between pin OSC and pin V_{SS}.

Five commands are available to configure and control the operation of the device. Communication is made via a two-line bidirectional I²C-bus. The device may have one of two slave addresses. The only difference between these slave addresses is the least significant bit, which is set by the logic level applied to SA0. The PCF8578 and PCF8579 have different subaddresses. The subaddress of the PCF8578 is only defined in mixed mode and is fixed at 0111 100 (see [Section 8.8.7 on page 19](#)). The RAM may only be accessed in mixed mode and data is loaded as described for the PCF8579.

Bias levels may be generated by an external potential divider with appropriate decoupling capacitors. For large displays, bias sources with high drive capability should be used. A typical mixed mode system operating with up to 15 PCF8579s is shown in [Figure 5](#) (a stand-alone system would be identical but without the PCF8579).

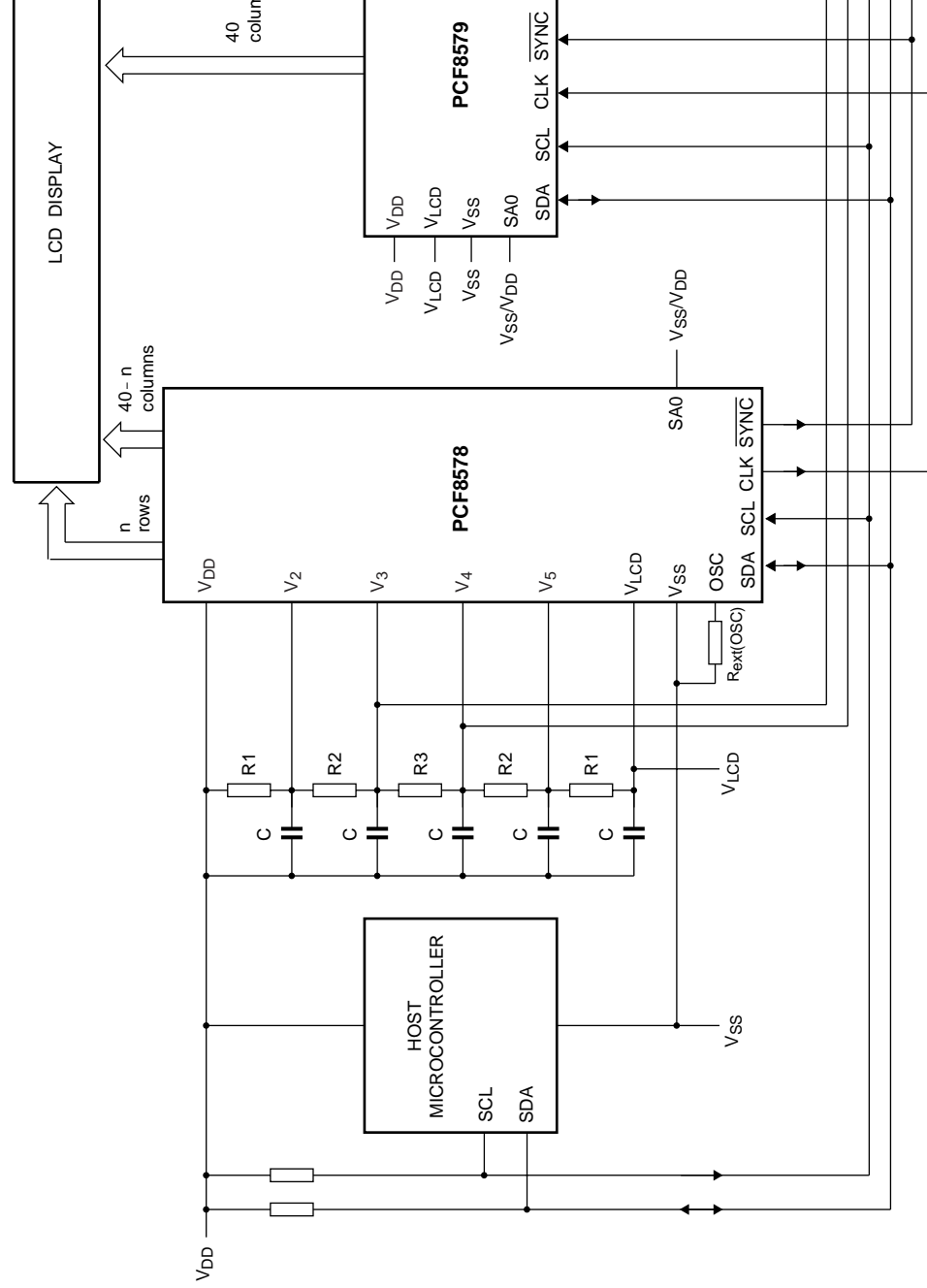

Fig 5. Typical mixed mode configuration

Table 5 shows the relative values of the resistors required in the configuration of Figure 5 to produce the standard multiplex rates.

Table 5. Multiplex rates and resistor values for Figure 5

Resistors	Multiplex rate (1:n)	
	n = 8	n = 16, 24, 32
R1	R	R
R2	$(\sqrt{n} - 2)R$	R
R3	$(3 - \sqrt{n})R$	$(\sqrt{n} - 3)R$

8.2 Power-on reset

At power-on the PCF8578 resets to a defined starting condition as follows:

1. Display blank
2. 1:32 multiplex rate, row mode
3. Start bank 0 selected
4. Data pointer is set to X, Y address 0, 0
5. Character mode
6. Subaddress counter is set to 0
7. I²C-bus interface is initialized

Remark: Do not transfer data on the I²C-bus for at least 1 ms after power-on to allow the reset action to complete.

8.3 Multiplexed LCD bias generation

The bias levels required to produce maximum contrast depend on the multiplex rate and the LCD threshold voltage (V_{th}). V_{th} is typically defined as the RMS voltage at which the LCD exhibits 10 % contrast. Table 6 shows the optimum voltage bias levels and Table 7 the discrimination ratios (D) for the different multiplex rates as functions of V_{oper} .

$$V_{oper} = V_{DD} - V_{LCD} \tag{1}$$

The RMS on-state voltage ($V_{on(RMS)}$) for the LCD is calculated with the equation

$$V_{on(RMS)} = V_{oper} \sqrt{\frac{1}{n} + \frac{\sqrt{n} - 1}{n(\sqrt{n} + 1)}} \tag{2}$$

and the RMS off-state voltage ($V_{off(RMS)}$) with the equation

$$V_{off(RMS)} = V_{oper} \sqrt{\frac{2(\sqrt{n} - 1)}{\sqrt{n}(\sqrt{n} + 1)^2}} \tag{3}$$

where the values for n are determined by the multiplex rate (1:n). Valid values for n are:

- n = 8 for 1:8 multiplex
- n = 16 for 1:16 multiplex
- n = 24 for 1:24 multiplex
- n = 32 for 1:32 multiplex

Table 6. Optimum LCD voltages

Bias ratios	Multiplex rate			
	1:8	1:16	1:24	1:32
$\frac{V_2}{V_{oper}}$	0.739	0.800	0.830	0.850
$\frac{V_3}{V_{oper}}$	0.522	0.600	0.661	0.700
$\frac{V_4}{V_{oper}}$	0.478	0.400	0.339	0.300
$\frac{V_5}{V_{oper}}$	0.261	0.200	0.170	0.150

Table 7. Discrimination ratios

Discrimination ratios	Multiplex rate			
	1:8	1:16	1:24	1:32
$\frac{V_{off(RMS)}}{V_{oper}}$	0.297	0.245	0.214	0.193
$\frac{V_{on(RMS)}}{V_{oper}}$	0.430	0.316	0.263	0.230
$D = \frac{V_{on(RMS)}}{V_{off(RMS)}}$	1.447	1.291	1.230	1.196
$\frac{V_{oper}}{V_{th}}$	3.370	4.080	4.680	5.190

Figure 6 shows the values of Table 6 as graphs.

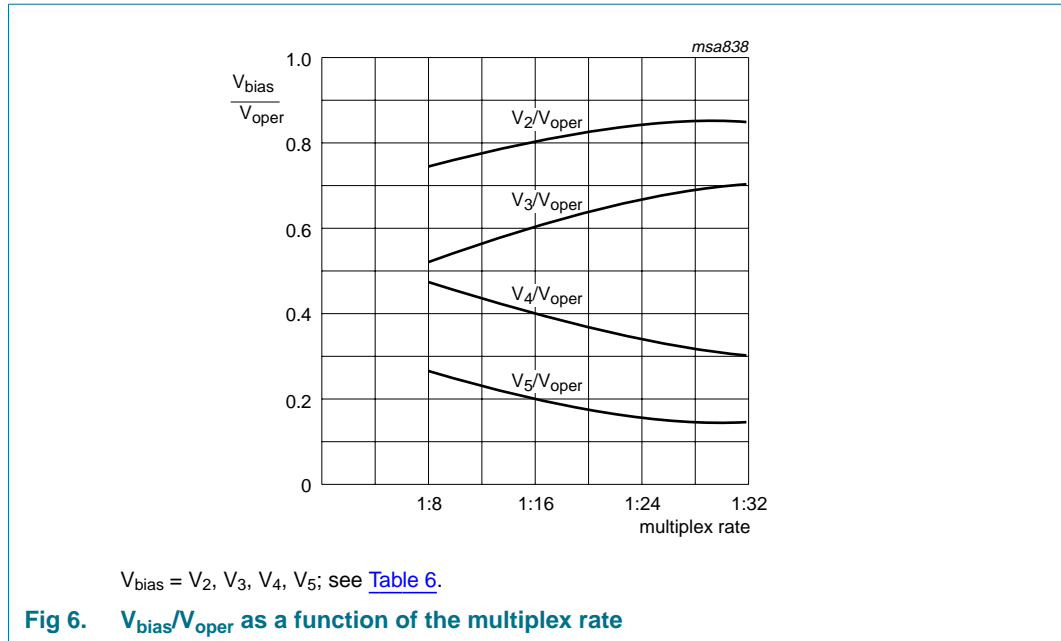

8.4 LCD drive mode waveforms

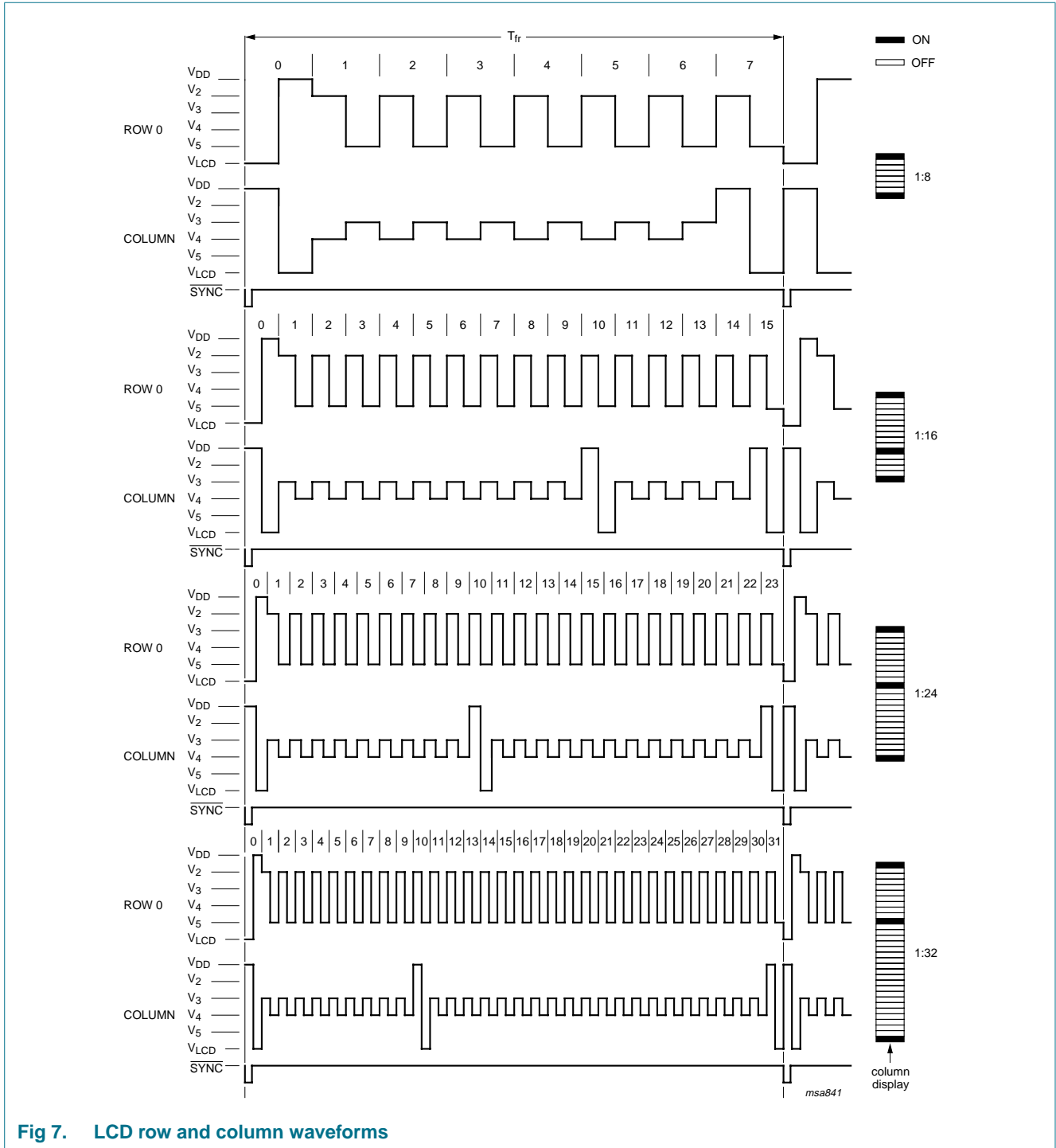
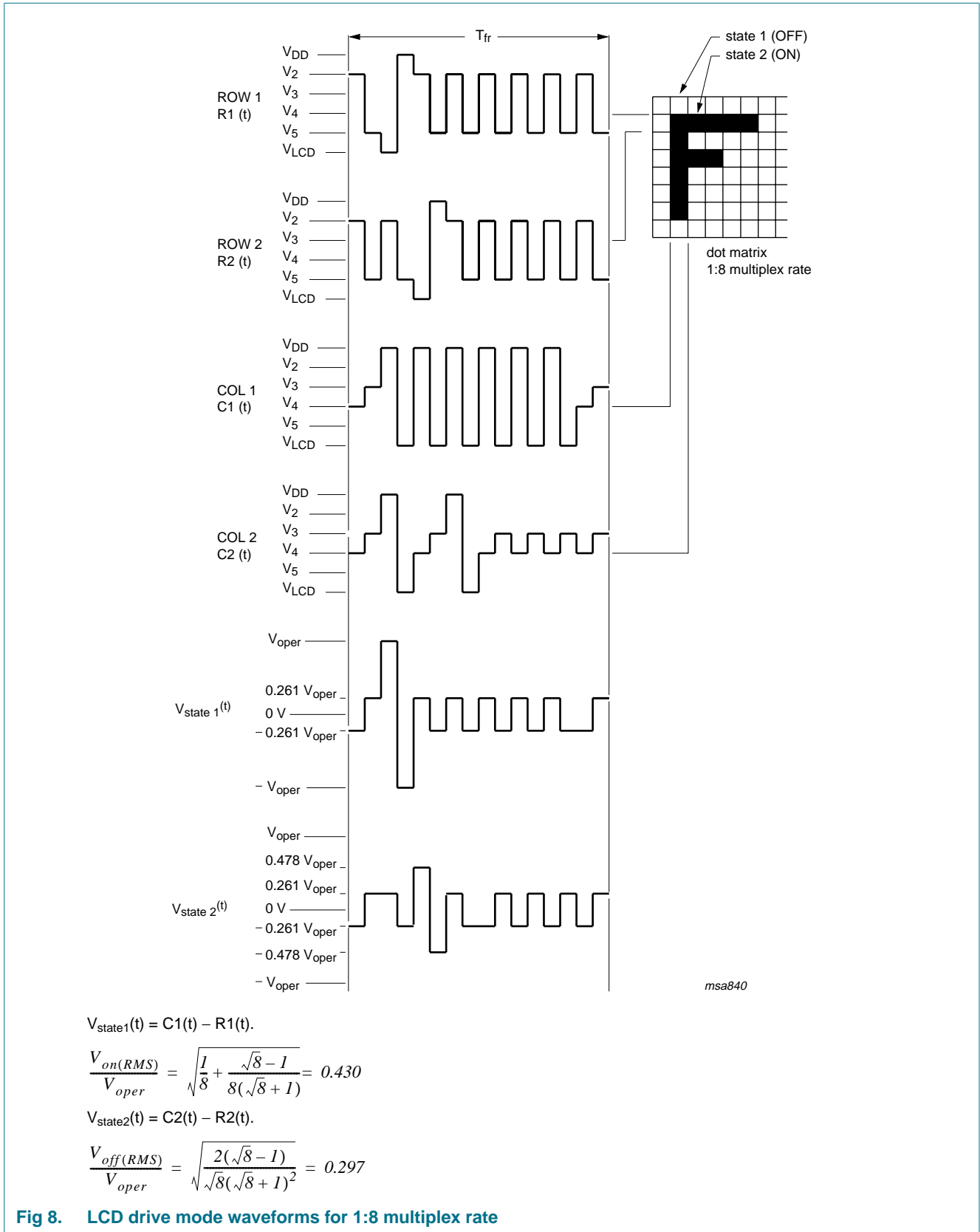
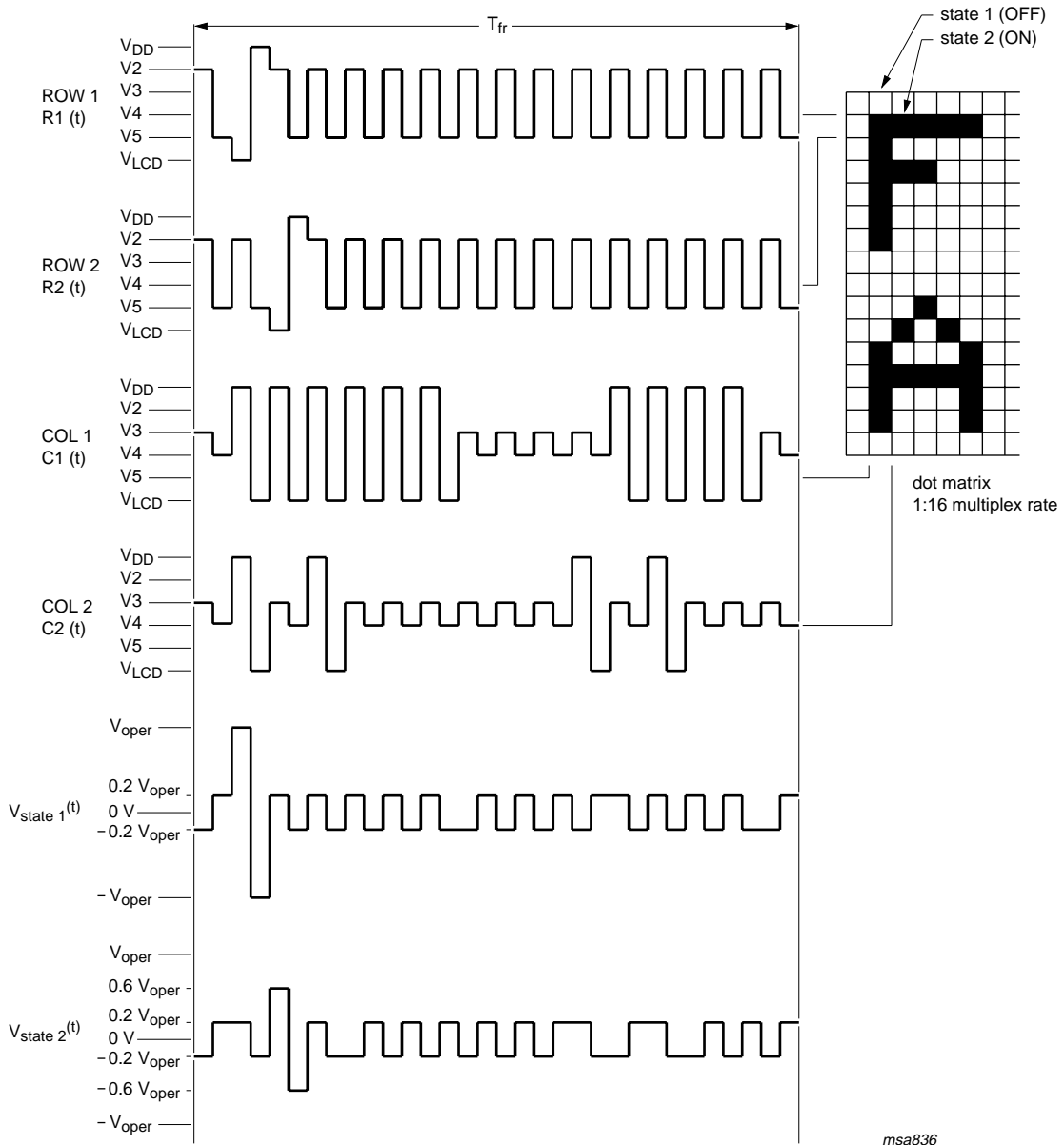

Fig 7. LCD row and column waveforms





msa836

$$V_{state1}(t) = C1(t) - R1(t).$$

$$\frac{V_{on(RMS)}}{V_{oper}} = \sqrt{\frac{1}{16} + \frac{\sqrt{16}-1}{16(\sqrt{16}+1)}} = 0.316$$

$$V_{state2}(t) = C2(t) - R2(t).$$

$$\frac{V_{off(RMS)}}{V_{oper}} = \sqrt{\frac{2(\sqrt{16}-1)}{\sqrt{16}(\sqrt{16}+1)^2}} = 0.254$$

Fig 9. LCD drive mode waveform for 1:16 multiplex rate

8.5 Oscillator

8.5.1 Internal clock

The clock signal for the system may be generated by the internal oscillator and prescaler. The frequency is determined by the value of the resistor $R_{ext(OSC)}$, see [Figure 10](#). For normal use a value of 330 kΩ is recommended. The clock signal, for cascaded PCF8579s, is output at CLK and has a frequency of $\frac{1}{6}$ (multiplex rate 1:8, 1:16 and 1:32) or $\frac{1}{8}$ (multiplex rate 1:24) of the oscillator frequency.

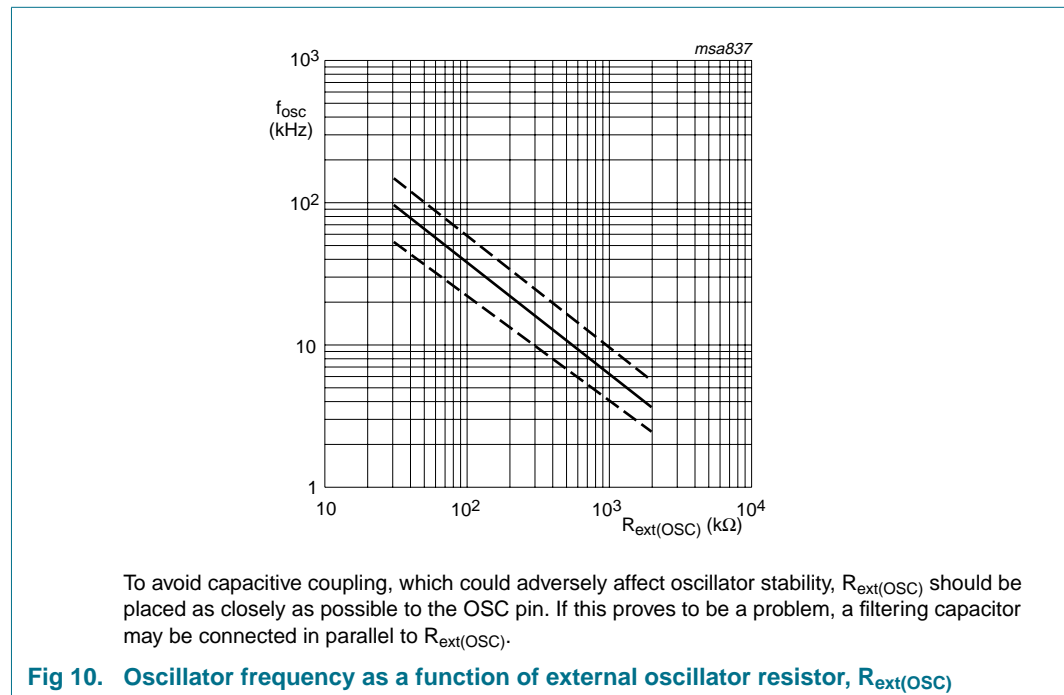

8.5.2 External clock

If an external clock is used, OSC must be connected to V_{DD} and the external clock signal to CLK. [Table 8](#) summarizes the nominal CLK and SYNC frequencies.

Table 8. Signal frequencies required for nominal 64 Hz frame frequency^[1]

Oscillator frequency, f_{osc} (Hz) ^[2]	Frame frequency, f_{fr} (Hz)	Multiplex rate, (1:n)	Division ratio	Clock frequency, f_{clk} (Hz)
12288	64	1:8, 1:16, 1:32	6	2048
12288	64	1:24	8	1536

[1] A clock signal must always be present, otherwise the LCD may be frozen in a DC state.

[2] $R_{ext(OSC)} = 330\text{ k}\Omega$.

8.6 Timing generator

The timing generator of the PCF8578 organizes the internal data flow of the device and generates the LCD frame synchronization pulse \overline{SYNC} , whose period is an integer multiple of the clock period. In cascaded applications, this signal maintains the correct timing relationship between the PCF8578 and PCF8579s in the system.

8.7 Row and column drivers

Outputs R0 to R7 and C32 to C39 are fixed as row and column drivers respectively. The remaining 24 outputs R8/C8 to R31/C31 are programmable and may be configured (in blocks of 8) to be either row or column drivers. The row select signal is produced sequentially at each output from R0 up to the number defined by the multiplex rate (see [Table 4](#)). In mixed mode the remaining outputs are configured as columns. In row mode all programmable outputs (R8/C8 to R31/C31) are defined as row drivers and the outputs C32 to C39 should be left open-circuit.

Using a 1:16 multiplex rate, two sets of row outputs are driven, thus facilitating split-screen configurations, i.e. a row select pulse appears simultaneously at R0 and R16/C16, R1 and R17/C17 etc. Similarly, using a multiplex rate of 1:8, four sets of row outputs are driven simultaneously. Driver outputs must be connected directly to the LCD. Unused outputs should be left open circuit.

Depending on the multiplex rate the following outputs are rows:

- In MUX 1:8 R0 to R7
- In MUX 1:16 R0 to R15/C15
- In MUX 1:24 R0 to R23/C23
- In MUX 1:32 R0 to R31/C31

The configuration of the outputs (row or column) and the selection of the appropriate driver waveforms are controlled by the display mode controller.

8.8 Characteristics of the I²C-bus

The I²C-bus is for bidirectional, two-line communication between different ICs or modules. The two lines are a Serial Data Line (SDA) and a Serial Clock Line (SCL) which must be connected to a positive supply via a pull-up resistor. Data transfer may be initiated only when the bus is not busy.

8.8.1 Bit transfer

One data bit is transferred during each clock pulse. The data on the SDA line must remain stable during the HIGH period of the clock pulse as changes in the data line at this moment will be interpreted as control signals.

8.8.2 START and STOP conditions

Both data and clock lines remain HIGH when the bus is not busy. A HIGH-to-LOW transition of the data line, while the clock is HIGH, is defined as the START condition (S). A LOW-to-HIGH transition of the data line while the clock is HIGH, is defined as the STOP condition (P).

8.8.3 System configuration

A device transmitting a message is a transmitter, a device receiving a message is the receiver. The device that controls the message flow is the master and the devices which are controlled by the master are the slaves.

8.8.4 Acknowledge

The number of data bytes transferred between the START and STOP conditions from transmitter to receiver is unlimited. Each data byte of eight bits is followed by one acknowledge bit. The acknowledge bit is a HIGH level put on the bus by the transmitter, whereas the master generates an extra acknowledge related clock pulse. A slave receiver which is addressed must generate an acknowledge after the reception of each byte. Also a master must generate an acknowledge after the reception of each byte that has been clocked out of the slave transmitter. The device that acknowledges must pull down the SDA line during the acknowledge clock pulse, so that the SDA line is stable LOW during the HIGH period of the acknowledge related clock pulse (set-up and hold times must be taken into consideration). A master receiver must signal the end of a data transmission to the transmitter by **not** generating an acknowledge on the last byte that has been clocked out of the slave. In this event the transmitter must leave the data line HIGH to enable the master to generate a STOP condition.

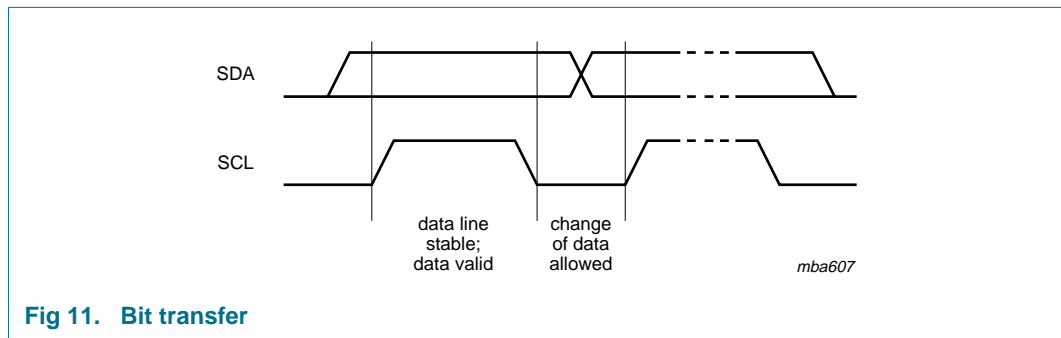

Fig 11. Bit transfer

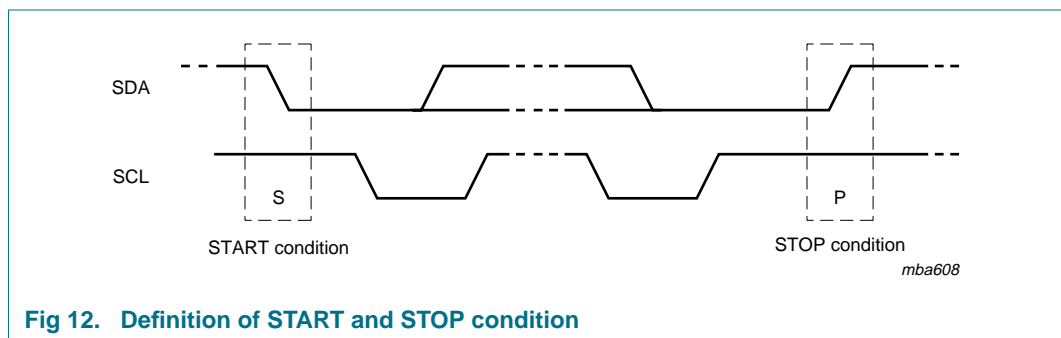

Fig 12. Definition of START and STOP condition

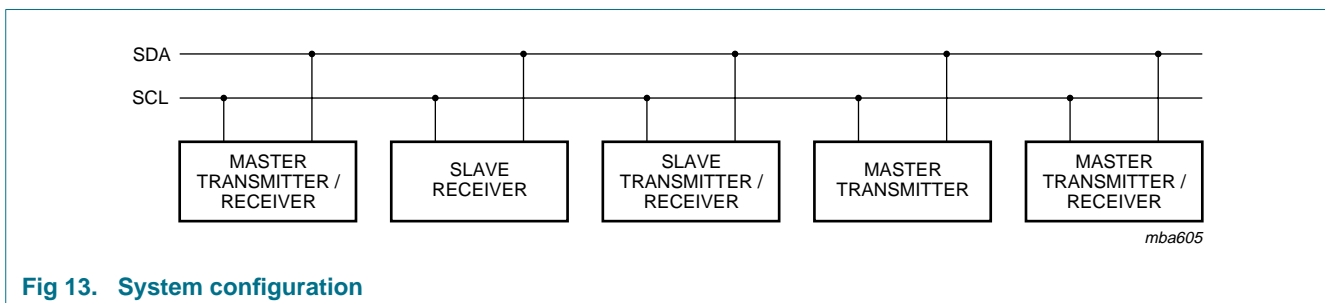
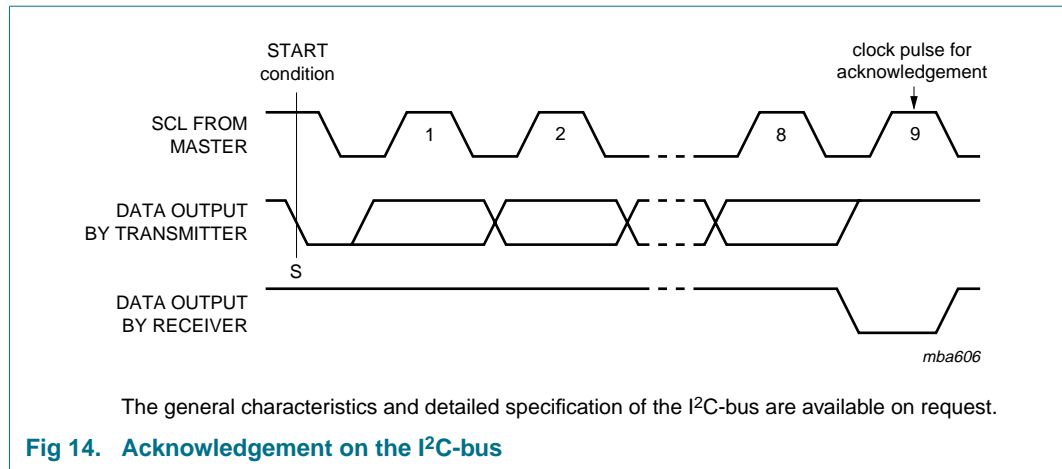

Fig 13. System configuration



8.8.5 I²C-bus controller

The I²C-bus controller detects the I²C-bus protocol, slave address, commands and display data bytes. It performs the conversion of the data input (serial-to-parallel) and the data output (parallel-to-serial). The PCF8578 acts as an I²C-bus slave transmitter/receiver in mixed mode, and as a slave receiver in row mode. A slave device cannot control bus communication.

8.8.6 Input filters

To enhance noise immunity in electrically adverse environments, RC low-pass filters are provided on the SDA and SCL lines.

8.8.7 I²C-bus protocol

Two 7-bit slave addresses (0111 100 and 0111 101) are reserved for both the PCF8578 and PCF8579. The least significant bit of the slave address is set by connecting input SA0 to either logic 0 (V_{SS}) or logic 1 (V_{DD}). Therefore, two types of PCF8578 or PCF8579 can be distinguished on the same I²C-bus which allows:

1. One PCF8578 to operate with up to 32 PCF8579s on the same I²C-bus for very large applications.
2. The use of two types of LCD multiplex schemes on the same I²C-bus.

In most applications the PCF8578 will have the same slave address as the PCF8579.

The I²C-bus protocol is shown in [Figure 15](#). All communications are initiated with a START condition (S) from the I²C-bus master, which is followed by the desired slave address and read/write bit. All devices with this slave address acknowledge in parallel. All other devices ignore the bus transfer.

In WRITE mode (indicated by setting the read/write bit LOW) one or more commands follow the slave address acknowledgement. The commands are also acknowledged by all addressed devices on the bus. The last command must clear the continuation bit C. After the last command a series of data bytes may follow. The acknowledgement after each byte is made only by the (A0, A1, A2 and A3) addressed PCF8579 or PCF8578 with its implicit subaddress 0. After the last data byte has been acknowledged, the I²C-bus master issues a STOP condition (P).

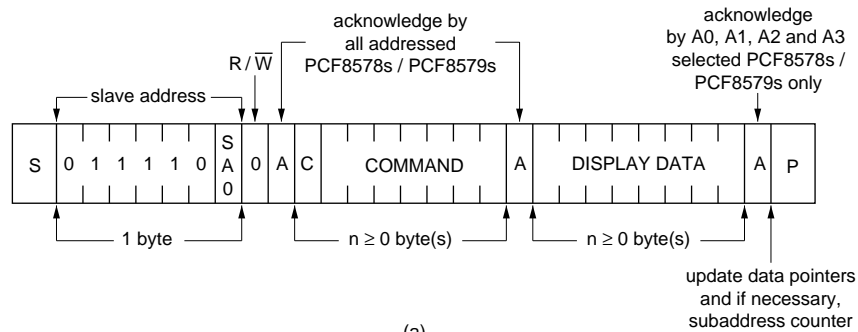

a. Master transmits to slave receiver (WRITE mode)

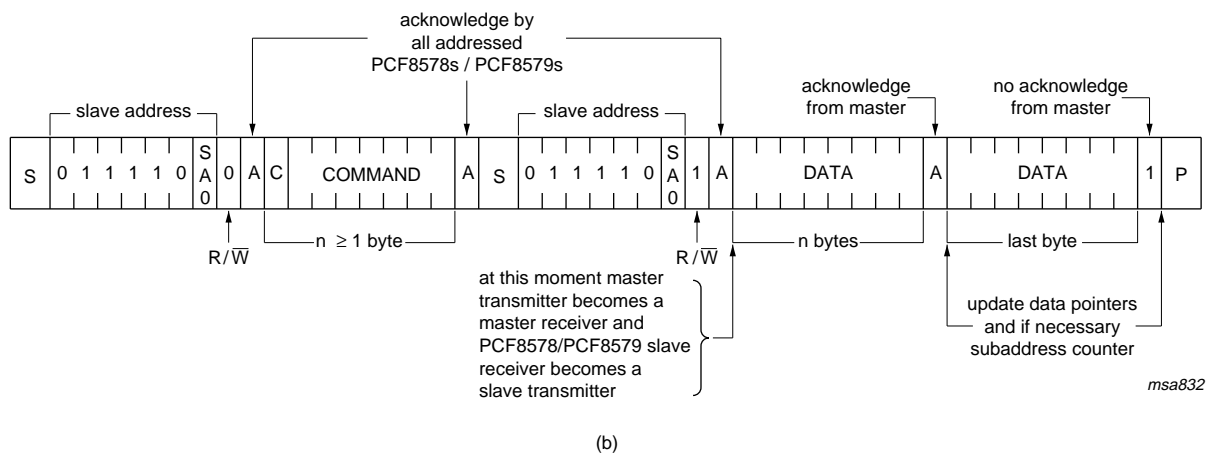

b. Master reads after sending command string (write commands; read data)

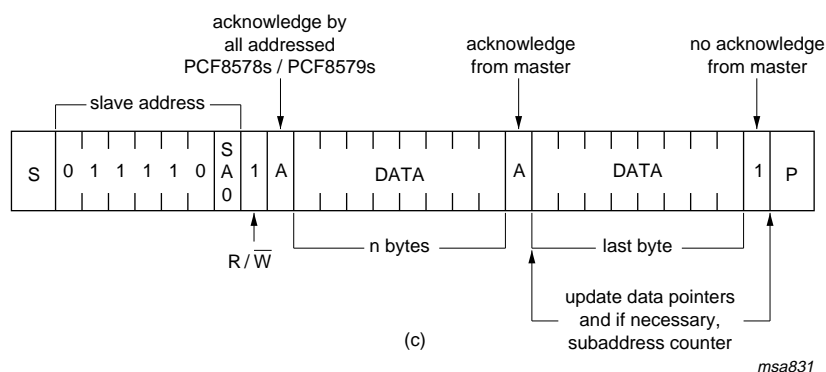

c. Master reads slave immediately after sending slave address (READ mode)

Fig 15. I²C-bus protocol

In READ mode, indicated by setting the read/write bit HIGH, data bytes may be read from the RAM following the slave address acknowledgement. After this acknowledgement the master transmitter becomes a master receiver and the PCF8578 becomes a slave transmitter. The master receiver must acknowledge the reception of each byte in turn. The

master receiver must signal an end of data to the slave transmitter, by not generating an acknowledge on the last byte clocked out of the slave. The slave transmitter then leaves the data line HIGH, enabling the master to generate a STOP condition (P).

Display bytes are written into, or read from the RAM at the address specified by the data pointer and subaddress counter. Both the data pointer and subaddress counter are automatically incremented, enabling a stream of data to be transferred either to, or from the intended devices.

In multiple device applications, the hardware subaddress pins of the PCF8579s (A0 to A3) are connected to V_{SS} or V_{DD} to represent the desired hardware subaddress code. If two or more devices share the same slave address, then each device **must** be allocated to a unique hardware subaddress.

8.9 Display RAM

The PCF8578 contains a 32 × 40-bit static RAM which stores the display data. The RAM is divided into 4 banks of 40 bytes (4 × 8 × 40 bits). During RAM access, data is transferred to and from the RAM via the I²C-bus. The first eight columns of data (0 to 7) cannot be displayed but are available for general data storage and provide compatibility with the PCF8579. There is a direct correspondence between X-address and column output number.

8.9.1 Data pointer

The addressing mechanism for the display RAM is realized using the data pointer. This allows an individual data byte or a series of data bytes to be written into, or read from, the display RAM, controlled by commands sent on the I²C-bus.

8.9.2 Subaddress counter

The storage and retrieval of display data is dependent on the content of the subaddress counter. Storage takes place only when the contents of the subaddress counter match with the hardware subaddress. The hardware subaddress of the PCF8578, valid in mixed mode only, is fixed at 0000.

8.10 Command decoder

The command decoder identifies command bytes that arrive on the I²C-bus.

The five commands available to the PCF8578 are defined in [Table 9](#).

Table 9. Definition of PCF8578 commands

Command	Operation code								Reference
	7	6	5	4	3	2	1	0	
set-mode	C	1	0	T	E[1:0]		M[1:0]		Table 11
set-start-bank	C	1	1	1	1	1	B[1:0]		Table 12
device-select	C	1	1	0	A[3:0]				Table 13
RAM-access	C	1	1	1	G[1:0]		Y[1:0]		Table 14
load-X-address	C	0	X[5:0]						Table 15

The most-significant bit of a command is the continuation bit C (see [Table 10](#) and [Figure 16](#)). Commands are transferred in WRITE mode only.

Table 10. C bit description

Bit	Symbol	Value	Description
7	C		continue bit
		0	last control byte in the transfer; next byte will be regarded as display data
		1	control bytes continue; next byte will be a command too

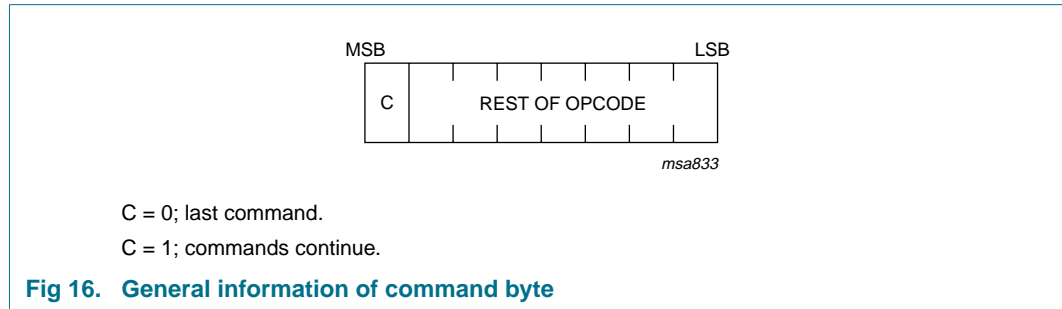

Table 11. Set-mode - command bit description

Bit	Symbol	Value	Description
7	C	0, 1	see Table 10
6, 5	-	10	fixed value
4	T		display mode
		0	row mode
		1	mixed mode
3, 2	E[1:0]		display status
		00	blank
		01	normal
		10	all segments on
		11	inverse video
1, 0	M[1:0]		LCD drive mode
		01	1:8 MUX (8 rows)
		10	1:16 MUX (16 rows)
		11	1:24 MUX (24 rows)
		00	1:32 MUX (32 rows)

Table 12. Set-start-bank - command bit description

Bit	Symbol	Value	Description
7	C	0, 1	see Table 10
6 to 2	-	11111	fixed value
1, 0	B[1:0]		start bank pointer (see Figure 20) ^[1]
		00	bank 0
		01	bank 1
		10	bank 2
		11	bank 3

[1] Useful for scrolling, pseudo-motion and background preparation of new display content.

Table 13. Device-select - command bit description

Bit	Symbol	Value	Description
7	C	0, 1	see Table 10
6 to 4	-	110	fixed value
3 to 0	A[3:0]	0 to 15 ^[1]	hardware subaddress; 4 bit binary value; transferred to the subaddress counter to define one of sixteen hardware subaddresses

[1] Values shown in decimal.

Table 14. RAM-access - command bit description

Bit	Symbol	Value	Description
7	C	0, 1	see Table 10
6 to 4	-	111	fixed value
3, 2	G[1:0]		RAM access mode; defines the auto-increment behavior of the address for RAM access (see Figure 18)
		00	character
		01	half-graphic
		10	full-graphic
		11	not allowed ^[1]
1, 0	Y[1:0]	0 to 3 ^[2]	RAM row address; two bits of immediate data, transferred to the Y-address pointer to define one of four display RAM rows (see Figure 17)

[1] See operation code for set-start-bank in [Table 12](#).

[2] Values shown in decimal.

Table 15. Load-X-address - command bit description

Bit	Symbol	Value	Description
7	C	0, 1	see Table 10
6	-	0	fixed value
5 to 0	X[5:0]	0 to 39 ^[1]	RAM column address; six bits of immediate data, transferred to the X-address pointer to define one of forty display RAM columns (see Figure 17)

[1] Values shown in decimal.

8.11 RAM access

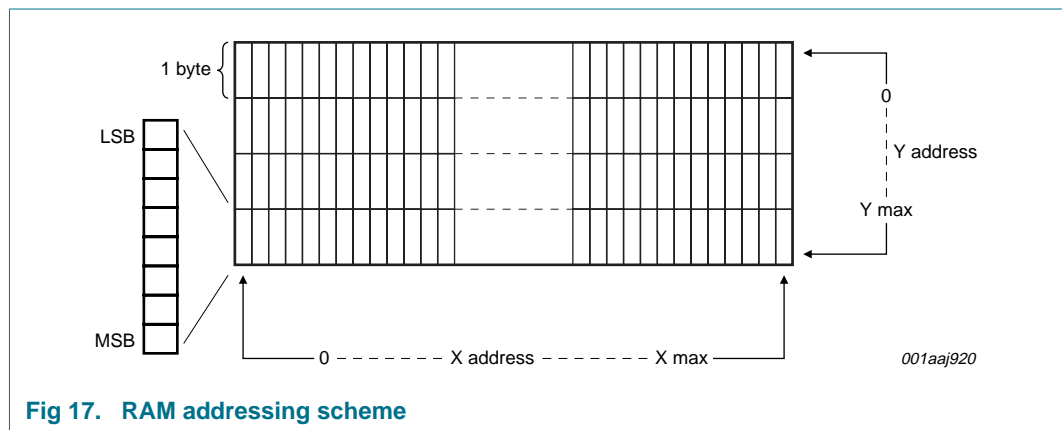

Fig 17. RAM addressing scheme

RAM operations are only possible when the PCF8578 is in mixed mode. In this event its hardware subaddress is internally fixed at 0000 and the hardware subaddresses of any PCF8579 used in conjunction with the PCF8578 must start at 0001.

There are three RAM-access modes:

- Character
- Half-graphic
- Full-graphic

These modes are specified by the bits G[1:0] of the RAM-access command. The RAM-access command controls the order in which data is written to or read from the RAM (see [Figure 18](#)).

To store RAM data, the user specifies the location into which the first byte will be loaded (see [Figure 19](#)):

- Device subaddress (specified by the device-select command)
- RAM X-address (specified by the bits X[5:0] of the load-X-address command)
- RAM bank (specified by the bits Y[1:0] of the RAM-access command)

Subsequent data bytes will be written or read according to the chosen RAM-access mode. Device subaddresses are automatically incremented between devices until the last device is reached. If the last device has subaddress 15, further display data transfers will lead to a wrap-around of the subaddress to 0.

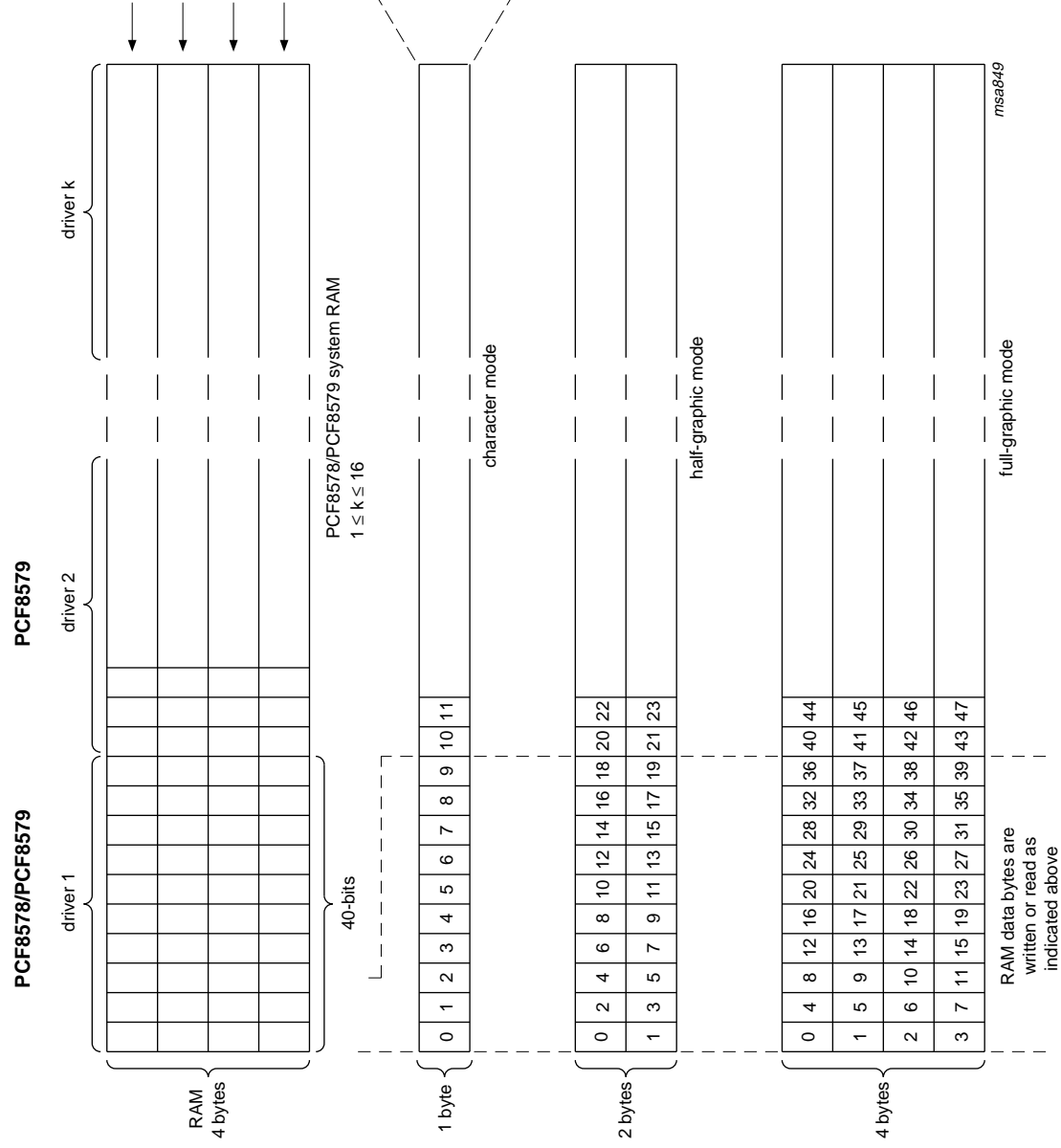

Fig 18. RAM access mode

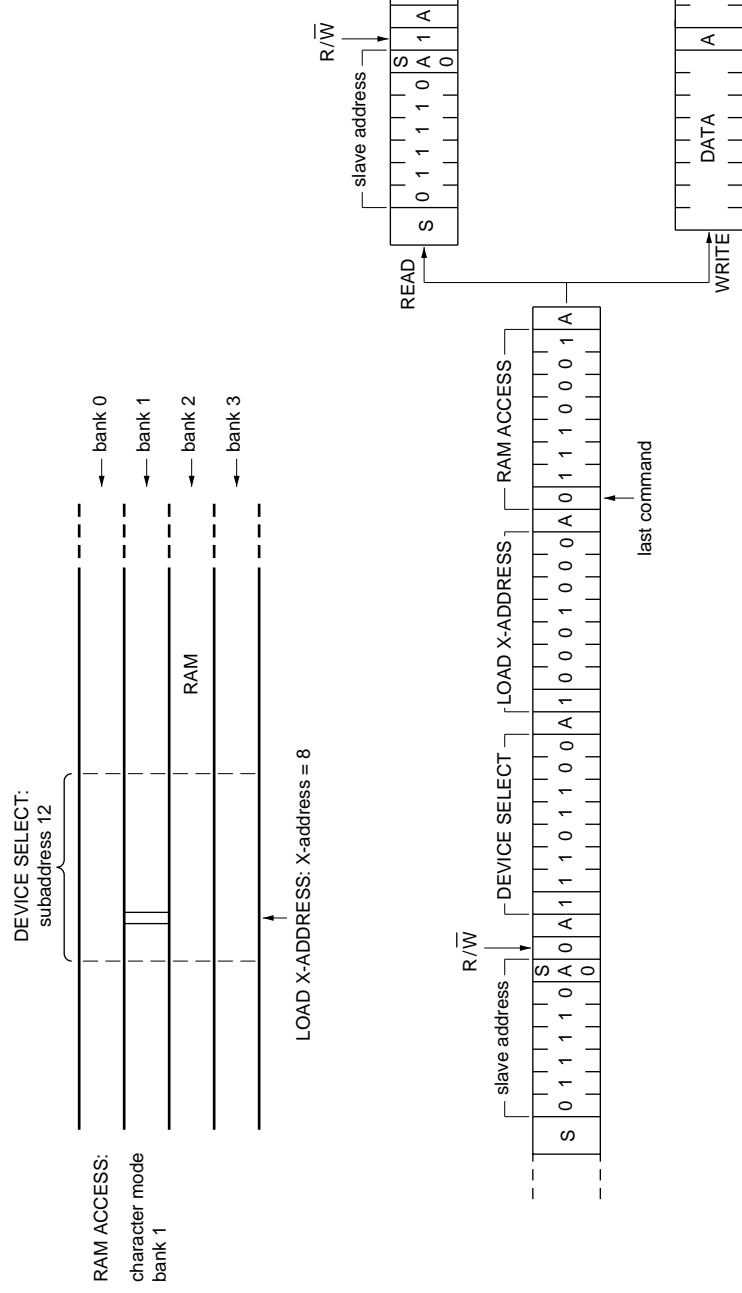
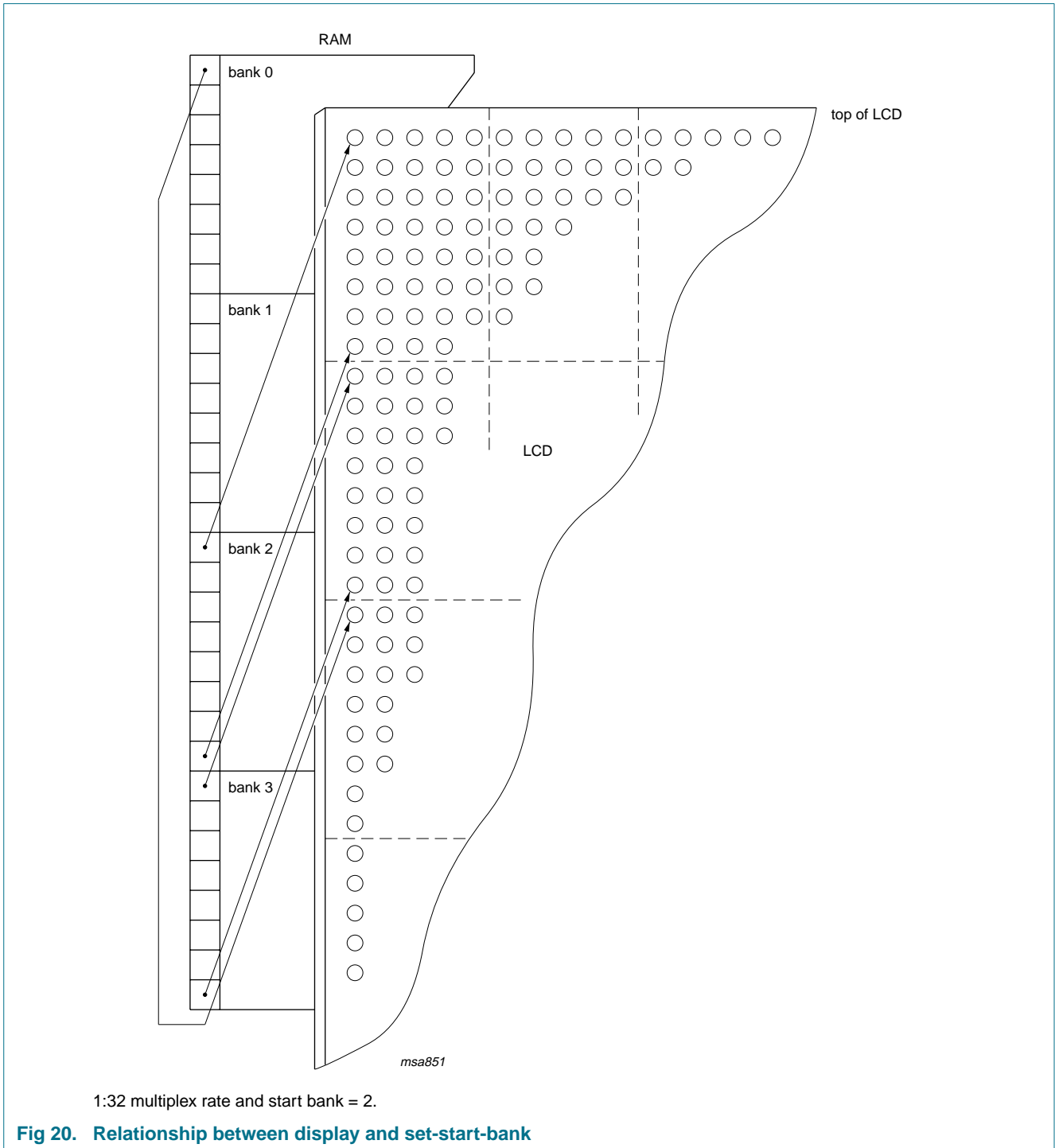

Fig 19. Example of commands specifying initial data byte RAM locations

8.12 Display control

The display is generated by continuously shifting rows of RAM data to the dot matrix LCD via the column outputs. The number of rows scanned depends on the multiplex rate set by bits M[1:0] of the set-mode command.



The display status (all dots on or off and normal or inverse video) is set by the bits E[1:0] of the set-mode command. For bank switching, the RAM bank corresponding to the top of the display is set by the bits B[1:0] of the set-start-bank command. This is shown in [Figure 20](#). This feature is useful when scrolling in alphanumeric applications.

9. Limiting values

Table 16. Limiting values

In accordance with the Absolute Maximum Rating System (IEC 60134).

Symbol	Parameter	Conditions	Min	Max	Unit
V_{DD}	supply voltage		-0.5	+8.0	V
V_{LCD}	LCD supply voltage		$V_{DD} - 11$	+8.0	V
V_I	input voltage	V_{DD} related; on pins SDA, SCL, CLK, TEST, SA0 and OSC	-0.5	+8.0	V
		V_{LCD} related; V_2 to V_5	$V_{DD} - 11$	+8.0	V
V_O	output voltage	V_{DD} related; \overline{SYNC} and CLK	-0.5	+8.0	V
		V_{LCD} related; R0 to R7, R8/C8 to R31/C31 and C32 to C39	$V_{DD} - 11$	+8.0	V
I_I	input current		-10	+10	mA
I_O	output current		-10	+10	mA
I_{DD}	supply current		-50	+50	mA
$I_{DD(LCD)}$	LCD supply current		-50	+50	mA
I_{SS}	ground supply current		-50	+50	mA
P_{tot}	total power dissipation	per package	-	400	mW
P_o	output power		-	100	mW
T_{stg}	storage temperature		[1] -65	+150	°C

[1] According to the NXP store and transport conditions (document *SNW-SQ-623*) the devices have to be stored at a temperature of +5 °C to +45 °C and a humidity of 25 % to 75 %.

10. Static characteristics

Table 17. Static characteristics

$V_{DD} = 2.5\text{ V to }6\text{ V}$; $V_{SS} = 0\text{ V}$; $V_{LCD} = V_{DD} - 3.5\text{ V to }V_{DD} - 9\text{ V}$; $T_{amb} = -40\text{ }^{\circ}\text{C to }+85\text{ }^{\circ}\text{C}$; unless otherwise specified.

Symbol	Parameter	Conditions	Min	Typ	Max	Unit
Supplies						
V_{DD}	supply voltage		2.5	-	6.0	V
V_{LCD}	LCD supply voltage		$V_{DD} - 9$	-	$V_{DD} - 3.5$	V
I_{DD}	supply current	external clock; $f_{clk} = 2\text{ kHz}$	[1] -	6	15	μA
		internal clock; $R_{ext(OSC)} = 330\text{ k}\Omega$	-	20	50	μA
V_{POR}	power-on reset voltage		[2] 0.8	1.3	1.8	V
Logic						
V_{IL}	LOW-level input voltage		V_{SS}	-	$0.3V_{DD}$	V
V_{IH}	HIGH-level input voltage		$0.7V_{DD}$	-	V_{DD}	V
I_{OL}	LOW-level output current	at pins $\overline{\text{SYNC}}$ and CLK; $V_{OL} = 1\text{ V}$; $V_{DD} = 5\text{ V}$	1	-	-	mA
		at pin SDA; $V_{OL} = 0.4\text{ V}$; $V_{DD} = 5\text{ V}$	3	-	-	mA
I_{OH}	HIGH-level output current	at pins $\overline{\text{SYNC}}$ and CLK; $V_{OH} = 4\text{ V}$; $V_{DD} = 5\text{ V}$;	-	-	-1	mA
I_L	leakage current	at pins SDA, SCL, $\overline{\text{SYNC}}$, CLK, TEST and SA0; $V_i = V_{DD}$ or V_{SS}	-1	-	+1	mA
		at pin OSC; $V_i = V_{DD}$	-1	-	+1	μA
C_i	capacitance for each I/O pin		[3] -	-	5	pF
LCD outputs						
I_L	leakage current	at pins V_2 to V_5 ; $V_i = V_{DD}$ or V_{LCD}	-2	-	+2	μA
$V_{offset(DC)}$	DC offset voltage	on pins R0 to R7, R8/C8 to R31/C31 and C32 to C39	-	± 20	-	mV
R_O	output resistance	on row output pins: R0 to R7 and R8/C8 to R31/C31	[4] -	1.5	3	k Ω
		on column output pins: R8/C8 to R31/C31 and C32 to C39	[4] -	3	6	k Ω

[1] Outputs are open; inputs at V_{DD} or V_{SS} ; I²C-bus inactive; external clock with 50 % duty factor.

[2] Resets all logic when $V_{DD} < V_{POR}$.

[3] Periodically sampled; not 100 % tested.

[4] Resistance measured between output terminal (R0 to R7, R8/C8 to R31/C31 and C32 to C39) and bias input (V_2 to V_5 , V_{DD} and V_{LCD}) when the specified current flows through one output under the following conditions (see [Table 6 on page 11](#)):

a) $V_{oper} = V_{DD} - V_{LCD} = 9\text{ V}$.

b) Row mode, R0 to R7 and R8/C8 to R31/C31: $V_2 - V_{LCD} \geq 6.65\text{ V}$; $V_5 - V_{LCD} \leq 2.35\text{ V}$; $I_{load} = 150\text{ }\mu\text{A}$.

c) Column mode, R8/C8 to R31/C31 and C32 to C39: $V_3 - V_{LCD} \geq 4.70\text{ V}$; $V_4 - V_{LCD} \leq 4.30\text{ V}$; $I_{load} = 100\text{ }\mu\text{A}$.

11. Dynamic characteristics

Table 18. Dynamic characteristics

All timing values are referenced to V_{IH} and V_{IL} levels with an input voltage swing of V_{SS} to V_{DD} . $V_{DD} = 2.5\text{ V to }6\text{ V}$; $V_{SS} = 0\text{ V}$; $V_{LCD} = V_{DD} - 3.5\text{ V to }V_{DD} - 9\text{ V}$; $T_{amb} = -40\text{ }^{\circ}\text{C to }+85\text{ }^{\circ}\text{C}$; unless otherwise specified.

Symbol	Parameter	Conditions	Min	Typ	Max	Unit
f_{clk}	clock frequency	at multiplex rate 1:8, 1:16 and 1:32; $R_{ext(OSC)} = 330\text{ k}\Omega$; $V_{DD} = 6\text{ V}$	1.2	2.1	3.3	kHz
		at multiplex rate 1:24; $R_{ext(OSC)} = 330\text{ k}\Omega$; $V_{DD} = 6\text{ V}$	0.9	1.6	2.5	kHz
$t_{PD(SYNC_N)}$	\overline{SYNC} propagation delay		-	-	500	ns
$t_{PD(drv)}$	driver propagation delay	$V_{DD} - V_{LCD} = 9\text{ V}$; with test load of 45 pF	-	-	100	μs
I²C-bus						
f_{SCL}	SCL clock frequency		-	-	100	kHz
$t_{w(\text{spike})}$	spike pulse width		-	-	100	ns
t_{BUF}	bus free time between a STOP and START condition		4.7	-	-	μs
$t_{SU;STA}$	set-up time for a repeated START condition		4.7	-	-	μs
$t_{HD;STA}$	hold time (repeated) START condition		4.0	4.0	-	μs
t_{LOW}	LOW period of the SCL clock		4.7	-	-	μs
t_{HIGH}	HIGH period of the SCL clock		4.0	-	-	μs
t_r	rise time of both SDA and SCL signals		-	-	1	μs
t_f	fall time of both SDA and SCL signals		-	-	0.3	μs
$t_{SU;DAT}$	data set-up time		250	-	-	ns
$t_{HD;DAT}$	data hold time		0	-	-	ns
$t_{SU;STO}$	set-up time for STOP condition		4.0	-	-	μs

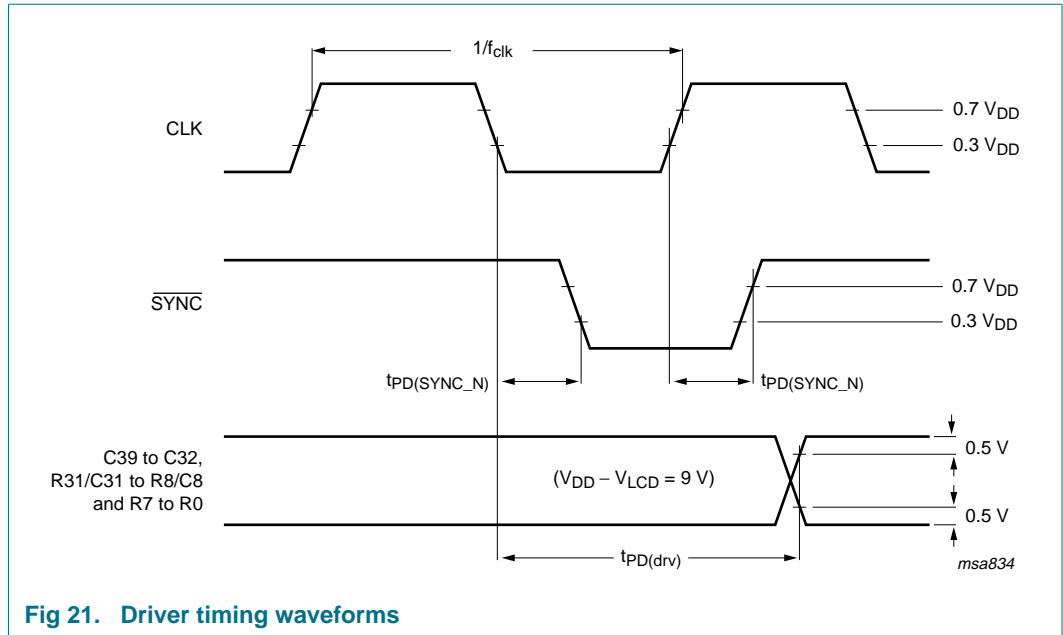

Fig 21. Driver timing waveforms

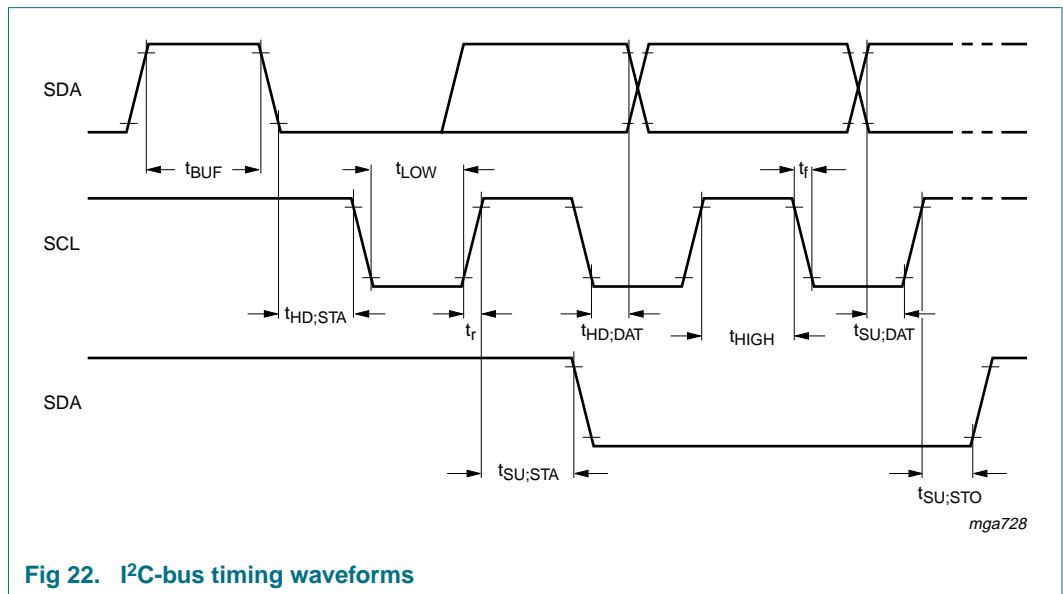

Fig 22. I²C-bus timing waveforms

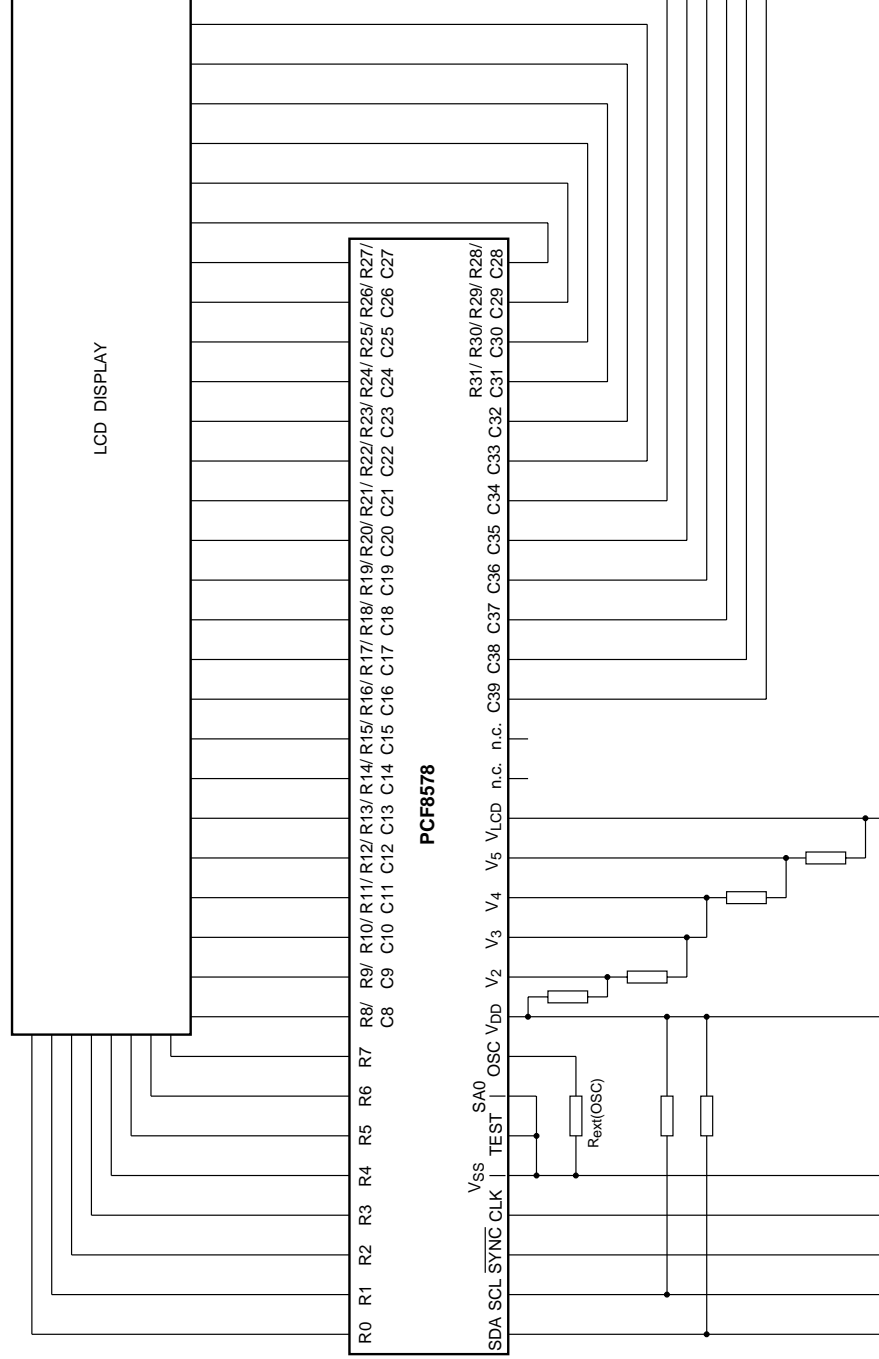

Fig 23. Stand alone application using 8 rows and 32 columns

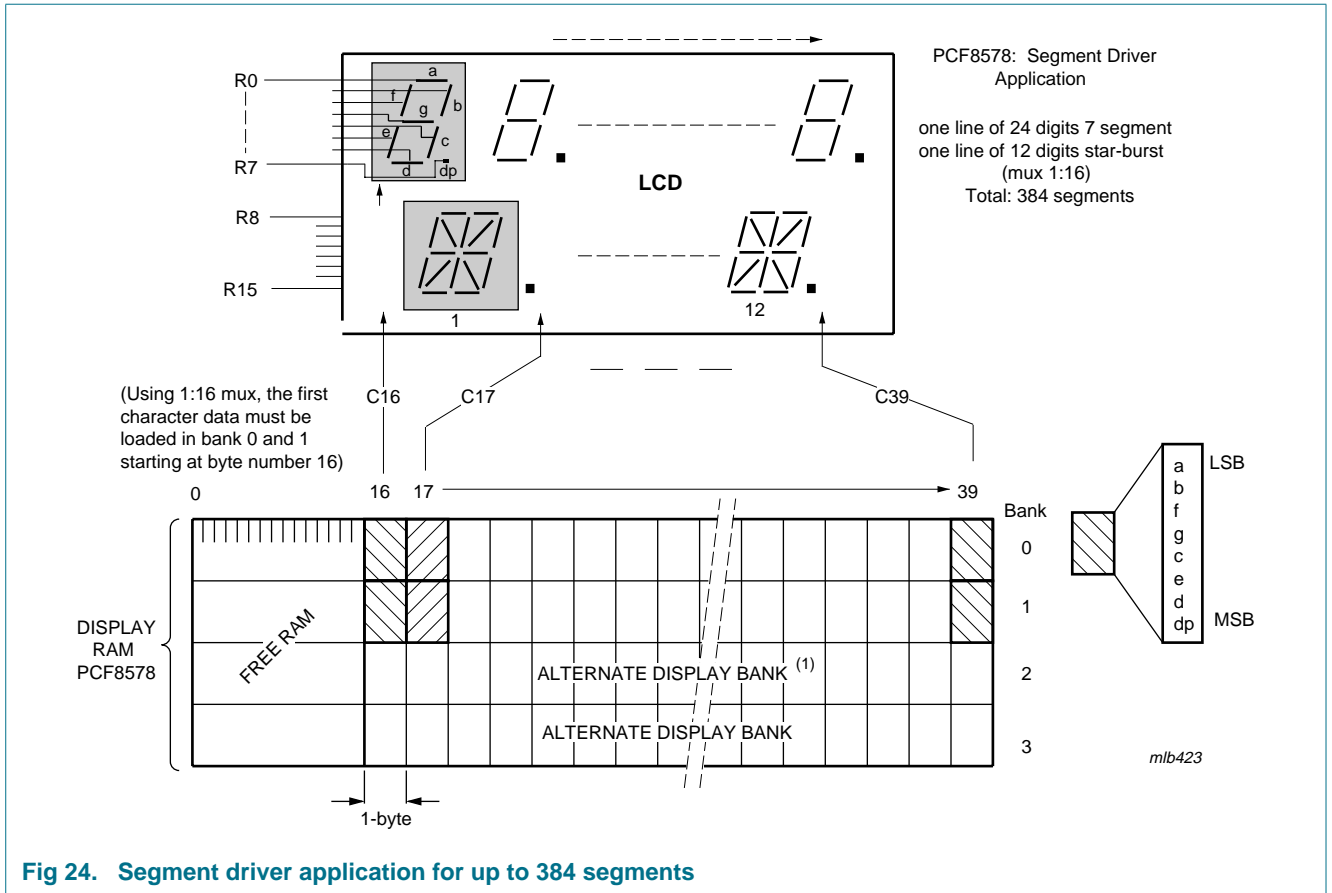

Fig 24. Segment driver application for up to 384 segments

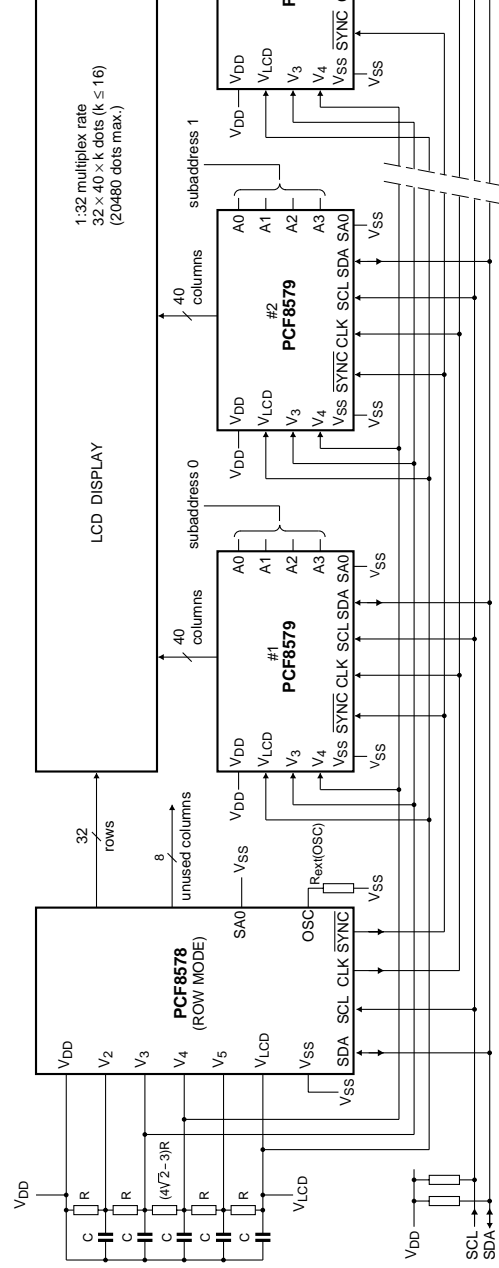

Fig 25. Typical LCD driver system with 1:32 multiplex rate

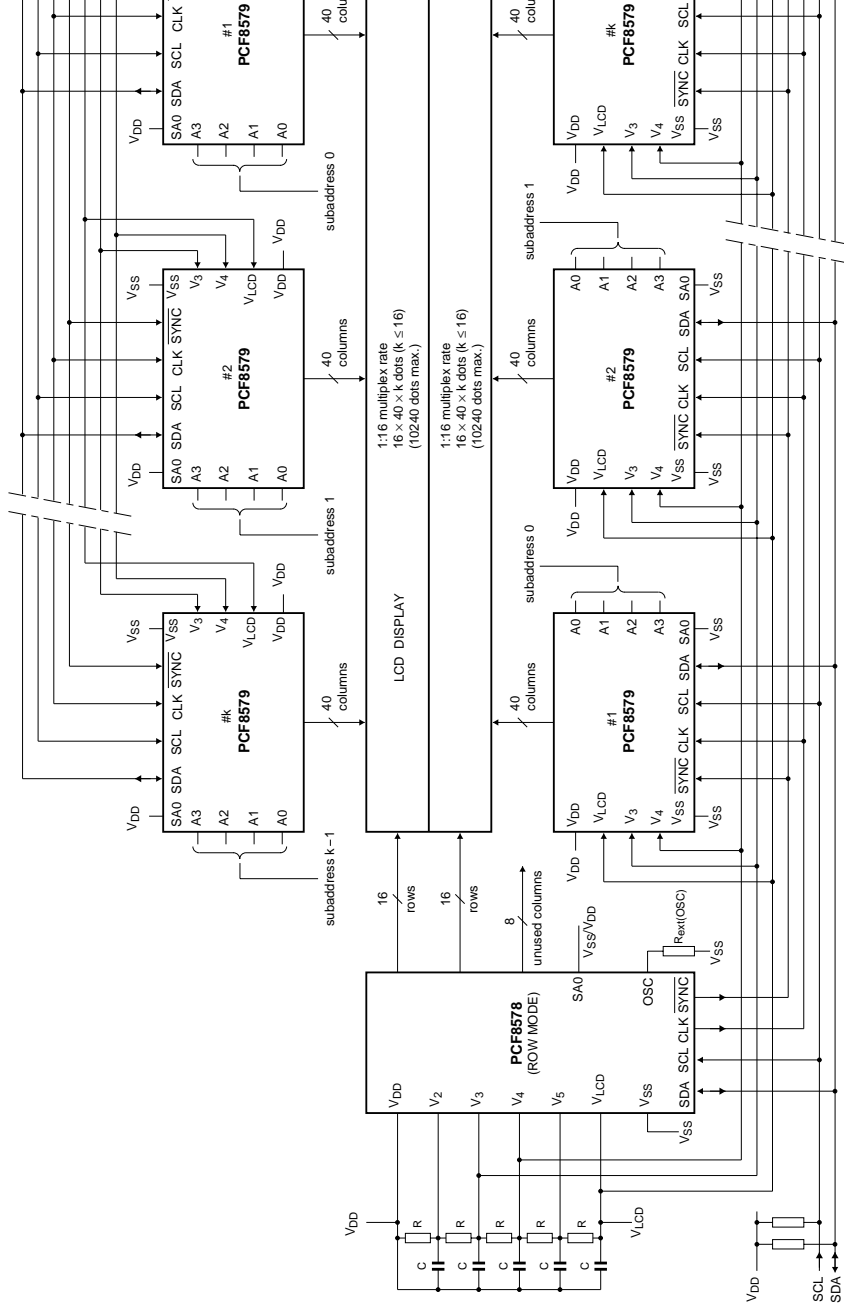

Fig 26. Split screen application with 1:16 multiplex rate for improved contrast

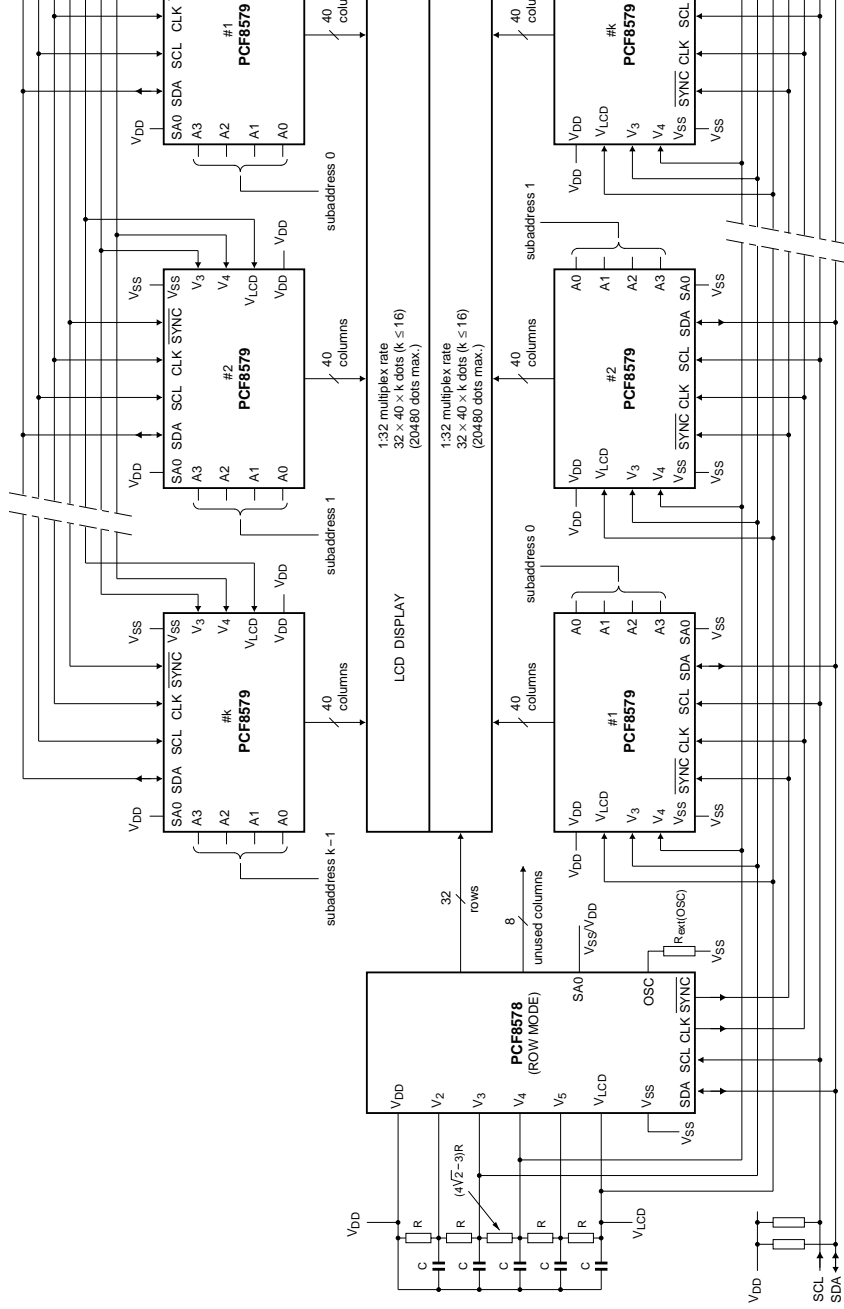

Fig 27. Split screen application with 1:32 multiplex rate

13. Package outline

VSO56: plastic very small outline package; 56 leads

SOT190-1

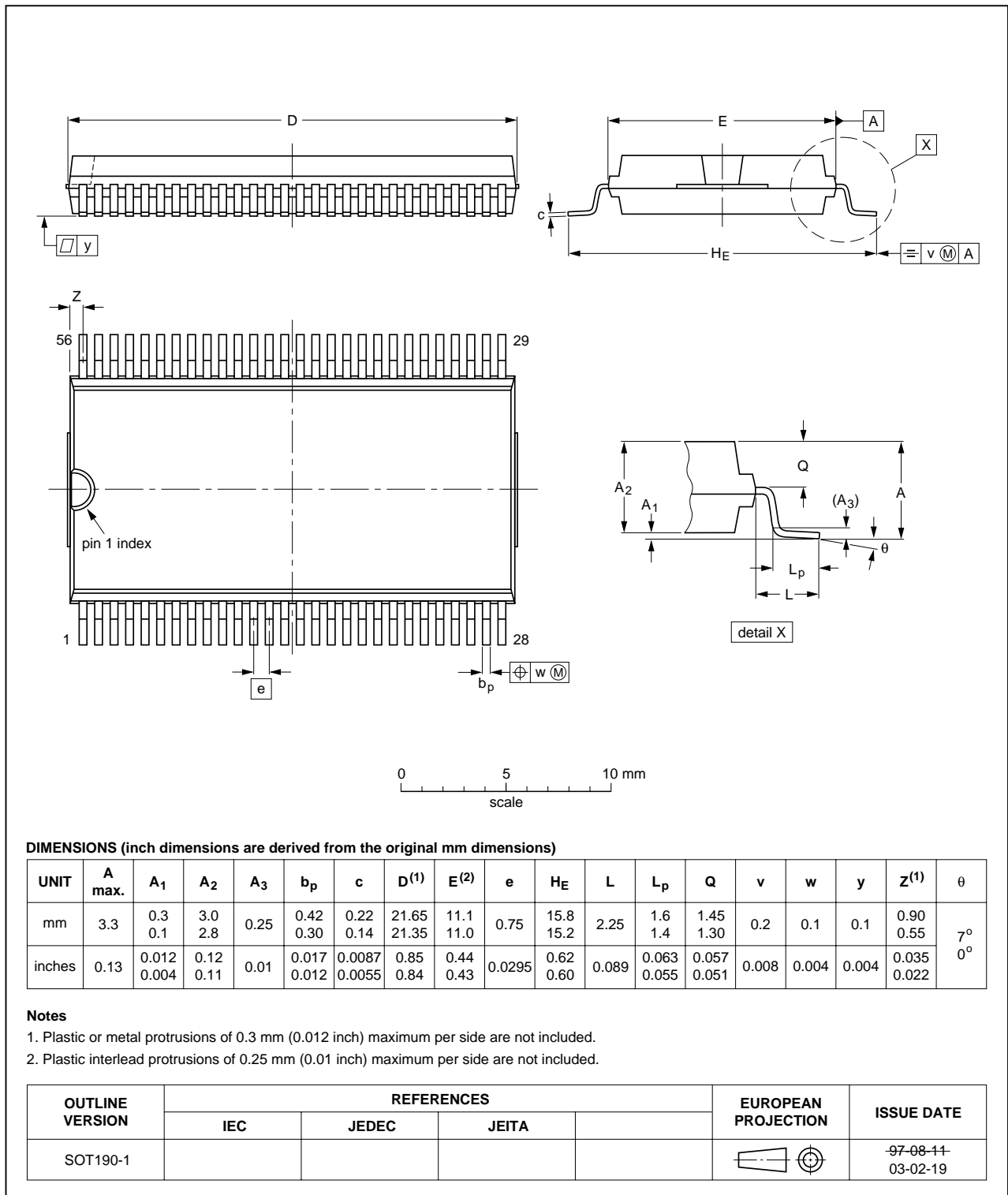

Fig 29. Package outline SOT190-1 (VSO56) of PCF8578T/1

LQFP64: plastic low profile quad flat package; 64 leads; body 10 x 10 x 1.4 mm

SOT314-2

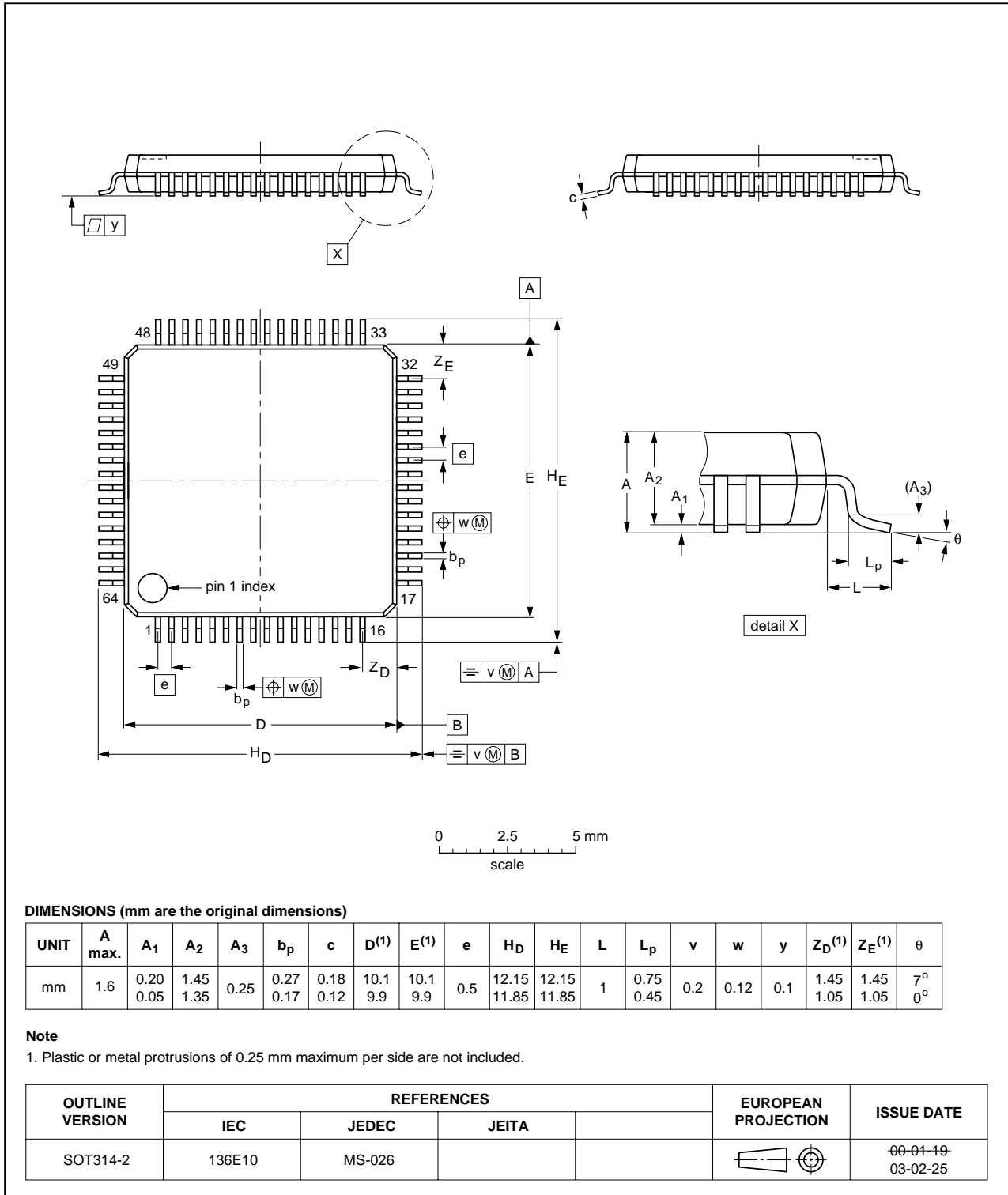

Fig 30. Package outline SOT314-2 (LQFP64) of PCF8578H/1

TQFP64: plastic thin quad flat package; 64 leads; body 10 x 10 x 1.0 mm

SOT357-1

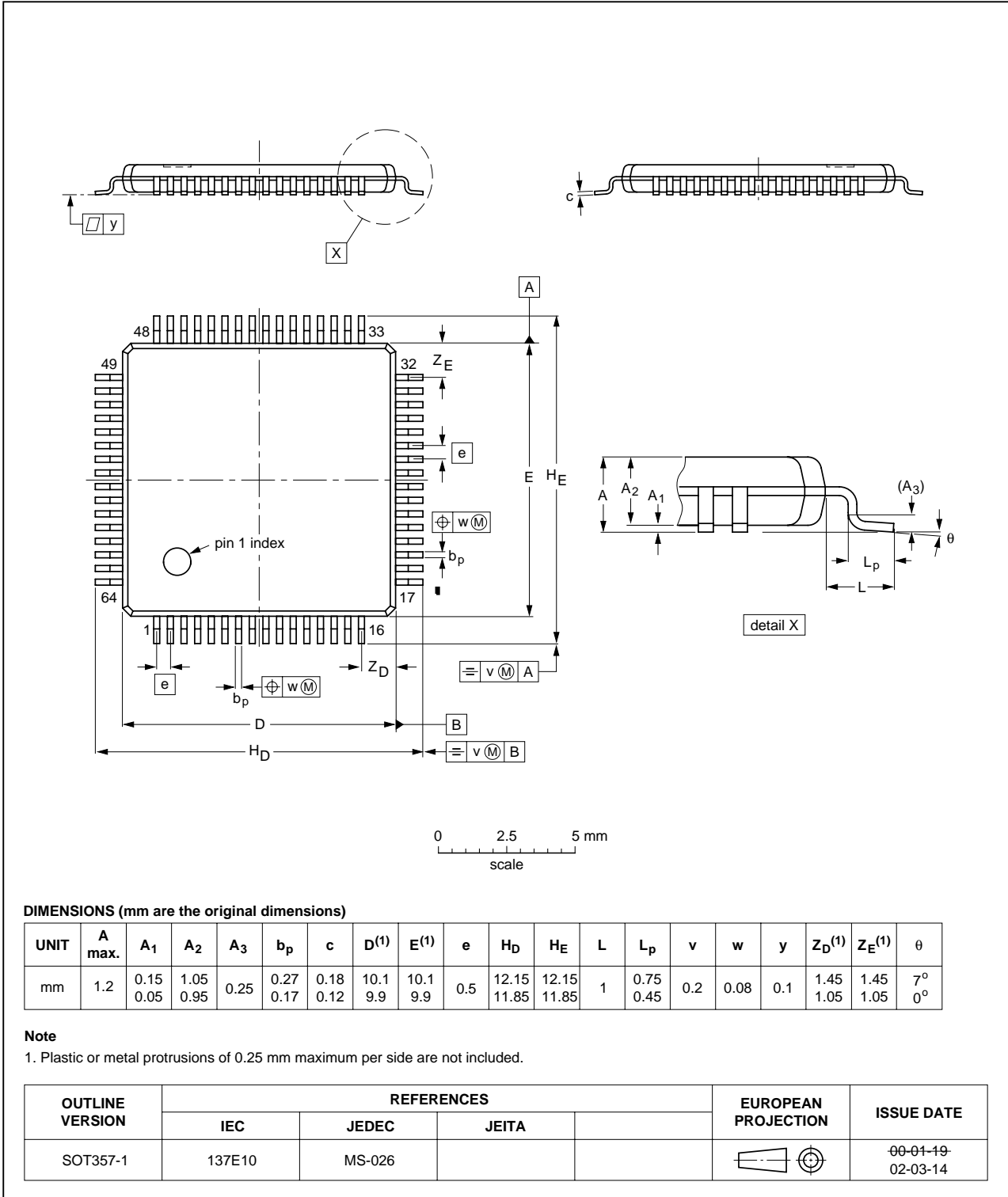

Fig 31. Package outline SOT357-1 (TQFP64) of PCF8578HT/1

14. Soldering of SMD packages

This text provides a very brief insight into a complex technology. A more in-depth account of soldering ICs can be found in Application Note *AN10365 "Surface mount reflow soldering description"*.

14.1 Introduction to soldering

Soldering is one of the most common methods through which packages are attached to Printed Circuit Boards (PCBs), to form electrical circuits. The soldered joint provides both the mechanical and the electrical connection. There is no single soldering method that is ideal for all IC packages. Wave soldering is often preferred when through-hole and Surface Mount Devices (SMDs) are mixed on one printed wiring board; however, it is not suitable for fine pitch SMDs. Reflow soldering is ideal for the small pitches and high densities that come with increased miniaturization.

14.2 Wave and reflow soldering

Wave soldering is a joining technology in which the joints are made by solder coming from a standing wave of liquid solder. The wave soldering process is suitable for the following:

- Through-hole components
- Leaded or leadless SMDs, which are glued to the surface of the printed circuit board

Not all SMDs can be wave soldered. Packages with solder balls, and some leadless packages which have solder lands underneath the body, cannot be wave soldered. Also, leaded SMDs with leads having a pitch smaller than ~0.6 mm cannot be wave soldered, due to an increased probability of bridging.

The reflow soldering process involves applying solder paste to a board, followed by component placement and exposure to a temperature profile. Leaded packages, packages with solder balls, and leadless packages are all reflow solderable.

Key characteristics in both wave and reflow soldering are:

- Board specifications, including the board finish, solder masks and vias
- Package footprints, including solder thieves and orientation
- The moisture sensitivity level of the packages
- Package placement
- Inspection and repair
- Lead-free soldering versus SnPb soldering

14.3 Wave soldering

Key characteristics in wave soldering are:

- Process issues, such as application of adhesive and flux, clinching of leads, board transport, the solder wave parameters, and the time during which components are exposed to the wave
- Solder bath specifications, including temperature and impurities

14.4 Reflow soldering

Key characteristics in reflow soldering are:

- Lead-free versus SnPb soldering; note that a lead-free reflow process usually leads to higher minimum peak temperatures (see [Figure 32](#)) than a SnPb process, thus reducing the process window
- Solder paste printing issues including smearing, release, and adjusting the process window for a mix of large and small components on one board
- Reflow temperature profile; this profile includes preheat, reflow (in which the board is heated to the peak temperature) and cooling down. It is imperative that the peak temperature is high enough for the solder to make reliable solder joints (a solder paste characteristic). In addition, the peak temperature must be low enough that the packages and/or boards are not damaged. The peak temperature of the package depends on package thickness and volume and is classified in accordance with [Table 19](#) and [20](#)

Table 19. SnPb eutectic process (from J-STD-020C)

Package thickness (mm)	Package reflow temperature (°C)	
	Volume (mm ³)	
	< 350	≥ 350
< 2.5	235	220
≥ 2.5	220	220

Table 20. Lead-free process (from J-STD-020C)

Package thickness (mm)	Package reflow temperature (°C)		
	Volume (mm ³)		
	< 350	350 to 2000	> 2000
< 1.6	260	260	260
1.6 to 2.5	260	250	245
> 2.5	250	245	245

Moisture sensitivity precautions, as indicated on the packing, must be respected at all times.

Studies have shown that small packages reach higher temperatures during reflow soldering, see [Figure 32](#).

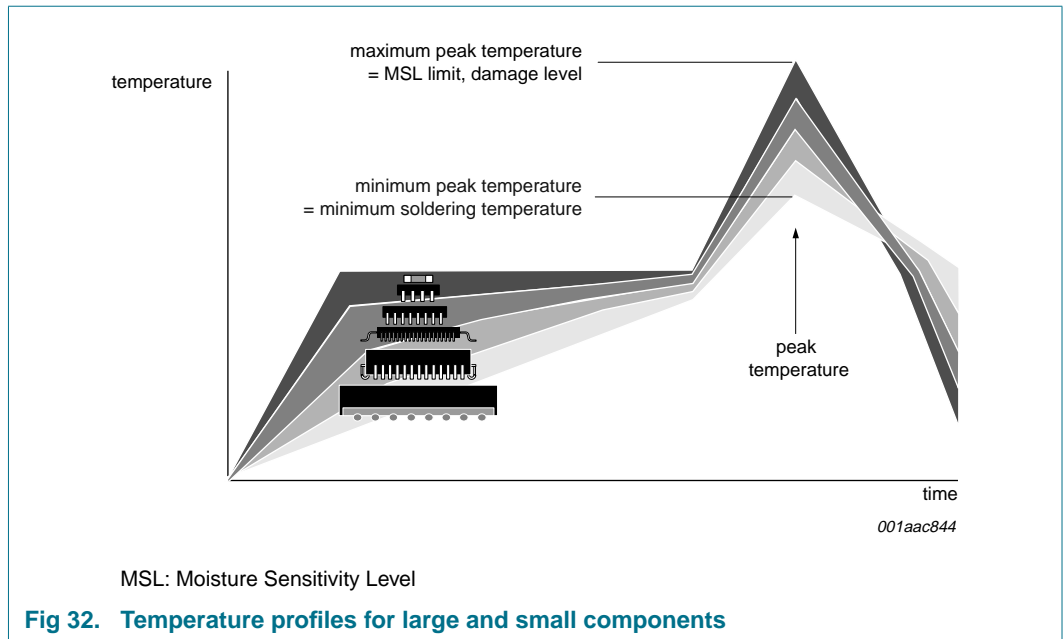

For further information on temperature profiles, refer to Application Note AN10365 “Surface mount reflow soldering description”.

15. Abbreviations

Table 21. Abbreviations

Acronym	Description
CMOS	Complementary Metal Oxide Semiconductor
DC	Direct Current
I ² C	Inter-Integrated Circuit
IC	Integrated Circuit
LCD	Liquid Crystal Display
LSB	Least Significant Bit
MSB	Most Significant Bit
MSL	Moisture Sensitivity Level
PCB	Printed-Circuit Board
POR	Power-On Reset
RC	Resistance-Capacitance
RAM	Random Access Memory
RMS	Root Mean Square
SCL	Serial Clock Line
SDA	Serial Data Line
SMD	Surface Mount Device

16. Revision history

Table 22. Revision history

Document ID	Release date	Data sheet status	Change notice	Supersedes
PCF8578_6	20090505	Product data sheet	-	PCF8578_5
Modifications:		<ul style="list-style-type: none"> • The format of this data sheet has been redesigned to comply with the new identity guidelines of NXP Semiconductors. • Legal texts have been adapted to the new company name where appropriate. • Added package type TQFP64 (PCF8578HT/1) • Removed bare die types • Rearranged information in data sheet • Corrected values for 1:32 multiplex mode in Table 4 • Changed letter symbols to NXP approved symbols • Added RAM addressing scheme (Figure 17) 		
PCF8578_5	20030414	Product specification	-	PCF8578_4
PCF8578_4	19980908	Product specification	-	PCF8578_3
PCF8578_3	19970328	Product specification	-	PCF8578_2
PCF8578_2	19961028	Product specification	-	PCF8578_1
PCF8578_1	19940125	Product specification	-	-

17. Legal information

17.1 Data sheet status

Document status ^{[1][2]}	Product status ^[3]	Definition
Objective [short] data sheet	Development	This document contains data from the objective specification for product development.
Preliminary [short] data sheet	Qualification	This document contains data from the preliminary specification.
Product [short] data sheet	Production	This document contains the product specification.

[1] Please consult the most recently issued document before initiating or completing a design.

[2] The term 'short data sheet' is explained in section "Definitions".

[3] The product status of device(s) described in this document may have changed since this document was published and may differ in case of multiple devices. The latest product status information is available on the Internet at URL <http://www.nxp.com>.

17.2 Definitions

Draft — The document is a draft version only. The content is still under internal review and subject to formal approval, which may result in modifications or additions. NXP Semiconductors does not give any representations or warranties as to the accuracy or completeness of information included herein and shall have no liability for the consequences of use of such information.

Short data sheet — A short data sheet is an extract from a full data sheet with the same product type number(s) and title. A short data sheet is intended for quick reference only and should not be relied upon to contain detailed and full information. For detailed and full information see the relevant full data sheet, which is available on request via the local NXP Semiconductors sales office. In case of any inconsistency or conflict with the short data sheet, the full data sheet shall prevail.

17.3 Disclaimers

General — Information in this document is believed to be accurate and reliable. However, NXP Semiconductors does not give any representations or warranties, expressed or implied, as to the accuracy or completeness of such information and shall have no liability for the consequences of use of such information.

Right to make changes — NXP Semiconductors reserves the right to make changes to information published in this document, including without limitation specifications and product descriptions, at any time and without notice. This document supersedes and replaces all information supplied prior to the publication hereof.

Suitability for use — NXP Semiconductors products are not designed, authorized or warranted to be suitable for use in medical, military, aircraft, space or life support equipment, nor in applications where failure or malfunction of an NXP Semiconductors product can reasonably be expected to result in personal injury, death or severe property or environmental

damage. NXP Semiconductors accepts no liability for inclusion and/or use of NXP Semiconductors products in such equipment or applications and therefore such inclusion and/or use is at the customer's own risk.

Applications — Applications that are described herein for any of these products are for illustrative purposes only. NXP Semiconductors makes no representation or warranty that such applications will be suitable for the specified use without further testing or modification.

Limiting values — Stress above one or more limiting values (as defined in the Absolute Maximum Ratings System of IEC 60134) may cause permanent damage to the device. Limiting values are stress ratings only and operation of the device at these or any other conditions above those given in the Characteristics sections of this document is not implied. Exposure to limiting values for extended periods may affect device reliability.

Terms and conditions of sale — NXP Semiconductors products are sold subject to the general terms and conditions of commercial sale, as published at <http://www.nxp.com/profile/terms>, including those pertaining to warranty, intellectual property rights infringement and limitation of liability, unless explicitly otherwise agreed to in writing by NXP Semiconductors. In case of any inconsistency or conflict between information in this document and such terms and conditions, the latter will prevail.

No offer to sell or license — Nothing in this document may be interpreted or construed as an offer to sell products that is open for acceptance or the grant, conveyance or implication of any license under any copyrights, patents or other industrial or intellectual property rights.

Export control — This document as well as the item(s) described herein may be subject to export control regulations. Export might require a prior authorization from national authorities.

17.4 Trademarks

Notice: All referenced brands, product names, service names and trademarks are the property of their respective owners.

I²C-bus — logo is a trademark of NXP B.V.

18. Contact information

For more information, please visit: <http://www.nxp.com>

For sales office addresses, please send an email to: salesaddresses@nxp.com

19. Contents

1	General description	1	17	Legal information	45
2	Features	1	17.1	Data sheet status	45
3	Applications	2	17.2	Definitions	45
4	Ordering information	2	17.3	Disclaimers	45
5	Marking	2	17.4	Trademarks	45
6	Block diagram	3	18	Contact information	45
7	Pinning information	4	19	Contents	46
7.1	Pinning	4			
7.2	Pin description	7			
8	Functional description	8			
8.1	Display configurations	8			
8.2	Power-on reset	10			
8.3	Multiplexed LCD bias generation	10			
8.4	LCD drive mode waveforms	13			
8.5	Oscillator	16			
8.5.1	Internal clock	16			
8.5.2	External clock	16			
8.6	Timing generator	16			
8.7	Row and column drivers	17			
8.8	Characteristics of the I ² C-bus	17			
8.8.1	Bit transfer	17			
8.8.2	START and STOP conditions	17			
8.8.3	System configuration	17			
8.8.4	Acknowledge	18			
8.8.5	I ² C-bus controller	19			
8.8.6	Input filters	19			
8.8.7	I ² C-bus protocol	19			
8.9	Display RAM	21			
8.9.1	Data pointer	21			
8.9.2	Subaddress counter	21			
8.10	Command decoder	21			
8.11	RAM access	24			
8.12	Display control	27			
9	Limiting values	28			
10	Static characteristics	29			
11	Dynamic characteristics	30			
12	Application information	32			
13	Package outline	38			
14	Soldering of SMD packages	41			
14.1	Introduction to soldering	41			
14.2	Wave and reflow soldering	41			
14.3	Wave soldering	41			
14.4	Reflow soldering	42			
15	Abbreviations	43			
16	Revision history	44			

Please be aware that important notices concerning this document and the product(s) described herein, have been included in section 'Legal information'.



© NXP B.V. 2009.

All rights reserved.

For more information, please visit: <http://www.nxp.com>

For sales office addresses, please send an email to: salesaddresses@nxp.com

Date of release: 5 May 2009

Document identifier: PCF8578_6



Looking for pricing, stock, or lifecycle information?

Click below to explore more details on WIN SOURCE:

 [View PCF8578HT/1,518 on WIN SOURCE](#)

 [NXP / Nexperia Information](#)

Optimize Your Supply Chain with WIN SOURCE Solutions

-  Global Sourcing Solution
-  Obsolete Management
-  Cost Control Management
-  Shortage Management
-  Alternative Solution
-  Excess Inventory Management