



PCA9632

4-bit Fm+ I²C-bus low power LED driver

Rev. 5 — 27 July 2011

Product data sheet

1. General description

The PCA9632 is an I²C-bus controlled 4-bit LED driver optimized for Red/Green/Blue/Amber (RGBA) color mixing applications. The PCA9632 is a drop-in upgrade for the PCA9633 with 40× power reduction. In Individual brightness control mode, each LED output has its own 8-bit resolution (256 steps) fixed frequency Individual PWM controller that operates at 1.5625 kHz with a duty cycle that is adjustable from 0 % to 99.6 % to allow the LED to be set to a specific brightness value. In group dimming mode, each LED output has its own 6-bit resolution (64 steps) fixed frequency Individual PWM controller that operates at 6.25 kHz with a duty cycle that is adjustable from 0 % to 98.4 % to allow the LED to be set to a specific brightness value. A fifth 4-bit resolution (16 steps) Group PWM controller has a fixed frequency of 190 Hz that is used to dim all the LEDs with the same value.

While operating in the Blink mode, each LED output has its own 8-bit resolution (256 steps) fixed frequency Individual PWM controller that operates at 1.5625 kHz with a duty cycle that is adjustable from 0 % to 99.6 % to allow the LED to be set to a specific brightness value. Blink rate is controlled by the Group frequency setting that has 8-bit resolution (256 steps). The blink rate is adjustable between 24 Hz and once every 10.73 seconds. For Group frequency settings between 6 Hz and 24 Hz, the Group PWM has a 6-bit resolution (64 steps) with a duty cycle that is adjustable from 0 % to 98.4 %. For Group frequency settings between 6 Hz and 0.09 Hz (once in 10.73 seconds), the Group PWM has an 8-bit resolution (256 steps) with a duty cycle that is adjustable from 0 % to 99.6 %.

Each LED output can be off, on (no PWM control), set at its Individual PWM controller value or at both Individual and Group PWM controller values. The LED output driver is programmed to be either open-drain with a 25 mA current sink capability at 5 V or totem pole with a 25 mA sink, 10 mA source capability at 5 V. The PCA9632 operates with a supply voltage range of 2.3 V to 5.5 V and the outputs are 5.5 V tolerant. LEDs can be directly connected to the LED output (up to 25 mA, 5.5 V) or controlled with external drivers and a minimum amount of discrete components for larger current or higher voltage LEDs.

The PCA9632 is in the new Fast-mode Plus (Fm+) family. Fm+ devices offer higher frequency (up to 1 MHz) and more densely populated bus operation (up to 4000 pF).

Software programmable LED Group and three Sub Call I²C-bus addresses allow all or defined groups of PCA9632 devices to respond to a common I²C-bus address, allowing for example, all red LEDs to be turned on or off at the same time or marquee chasing effect, thus minimizing I²C-bus commands.



The Software Reset (SWRST) Call allows the master to perform a reset of the PCA9632 through the I²C-bus, identical to the Power-On Reset (POR) that initializes the registers to their default state causing the outputs to be set high-impedance. This allows an easy and quick way to reconfigure all device registers to the same condition.

2. Features and benefits

- 40× power reduction compared to PCA9633
- 4 LED drivers. Each output programmable at:
 - ◆ Off
 - ◆ On
 - ◆ Programmable LED brightness
 - ◆ Programmable group dimming/blinking mixed with individual LED brightness
- 1 MHz Fast-mode Plus I²C-bus interface with 30 mA high drive capability on SDA output for driving high capacitive buses
- 256-step (8-bit) linear programmable brightness per LED output varying from fully off (default) to maximum brightness using a 1.5625 kHz PWM signal in Individual brightness mode
- 64-step (6-bit) linear programmable brightness for each LED output varying from fully off (default) to maximum brightness using a 6.25 kHz PWM signal in group dimming mode
- In group dimming mode, 16-step group brightness control allows global dimming (using a 190 Hz PWM signal) from fully off to maximum brightness (default)
- 256-step (8-bit) linear programmable brightness per LED output varying from fully off (default) to maximum brightness using a 1.5625 kHz PWM signal in group blinking mode
- 64-step group blinking with frequency programmable from 24 Hz to 6 Hz and duty cycle from 0 % to 98.4 %
- 256-step group blinking with frequency programmable from 6 Hz to 0.09 Hz (10.73 s) and duty cycle from 0 % to 99.6 %
- Four totem pole outputs (sink 25 mA and source 10 mA at 5 V) with software programmable open-drain LED outputs selection (default at high-impedance). No input function.
- 10-pin package option provides two hardware address pins allowing four devices to operate on the same bus
- Output state change programmable on the Acknowledge or the STOP Command to update outputs byte-by-byte or all at the same time (default to 'Change on STOP').
- Software Reset feature (SWRST Call) allows the device to be reset through the I²C-bus
- 400 kHz internal oscillator requires no external components
- Internal power-on reset
- Noise filter on SDA/SCL inputs
- Edge rate control on outputs
- No glitch on power-up
- Supports hot insertion
- Low standby current of < 1 μA
- Operating power supply voltage range of 2.3 V to 5.5 V

- 5.5 V tolerant inputs
- -40 °C to +85 °C operation
- ESD protection exceeds 5000 V HBM per JESD22-A114 and 1000 V CDM per JESD22-C101
- Latch-up testing is done to JEDEC Standard JESD78 which exceeds 100 mA
- Packages offered: TSSOP8, TSSOP10, HVSON8, HVSON10

3. Applications

- RGB or RGBA LED drivers for color mixing
- LED status information
- LED displays
- LCD backlights
- Keypad backlights for cellular phones or handheld devices

4. Ordering information

Table 1. Ordering information

| Type number | Topside mark | Package | | Version |
|-------------|--------------|---------|--|----------|
| | | Name | Description | |
| PCA9632DP1 | 9632 | TSSOP8 | plastic thin shrink small outline package; 8 leads; body width 3 mm | SOT505-1 |
| PCA9632DP2 | 9632 | TSSOP10 | plastic thin shrink small outline package; 10 leads; body width 3 mm | SOT552-1 |
| PCA9632TK | 9632 | HVSON8 | plastic thermal enhanced very thin small outline package; no leads; 8 terminals; body 3 × 3 × 0.85 mm | SOT908-1 |
| PCA9632TK2 | 9632 | HVSON10 | plastic thermal enhanced very thin small outline package; no leads; 10 terminals; body 3 × 3 × 0.85 mm | SOT650-1 |

5. Block diagram

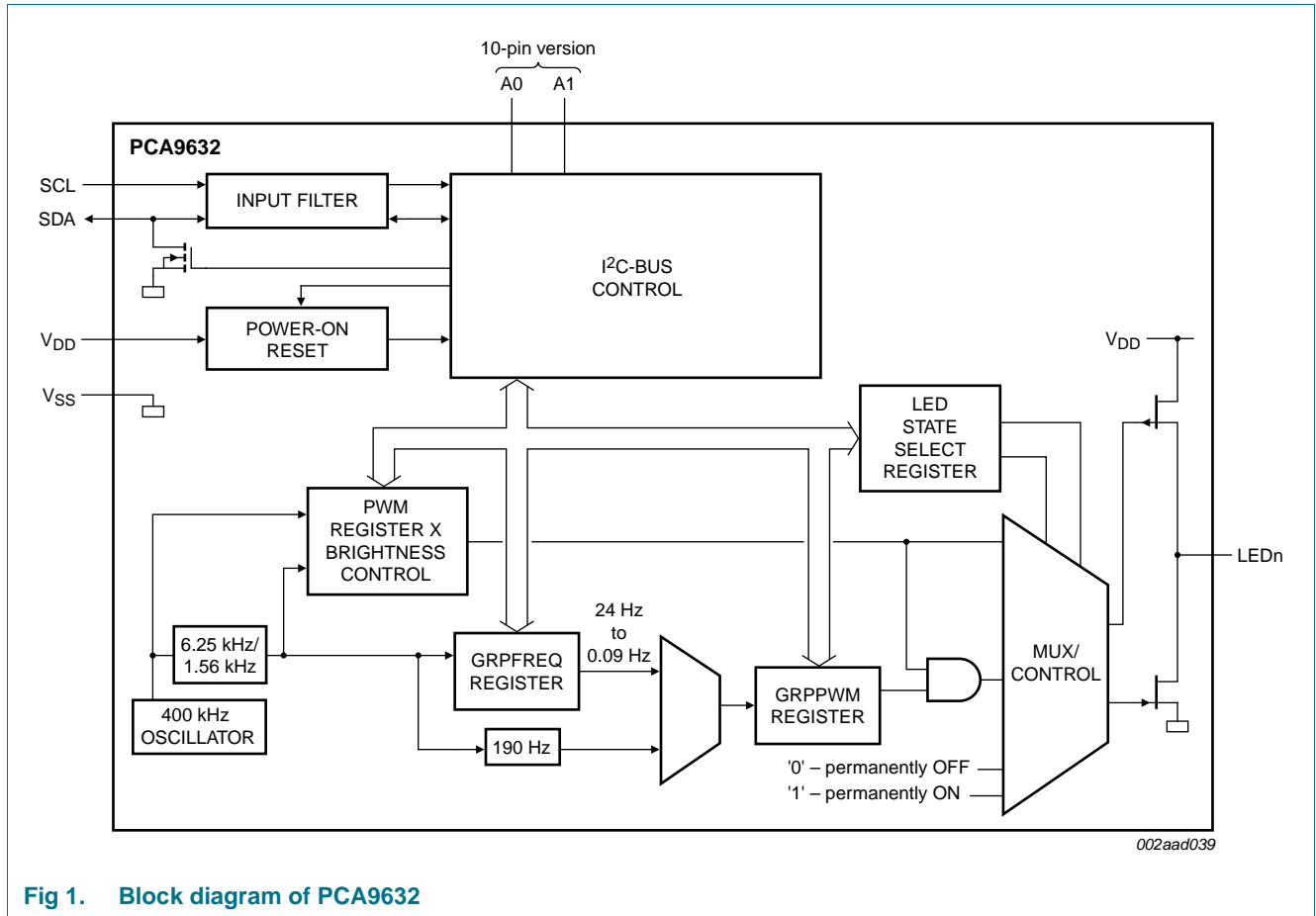
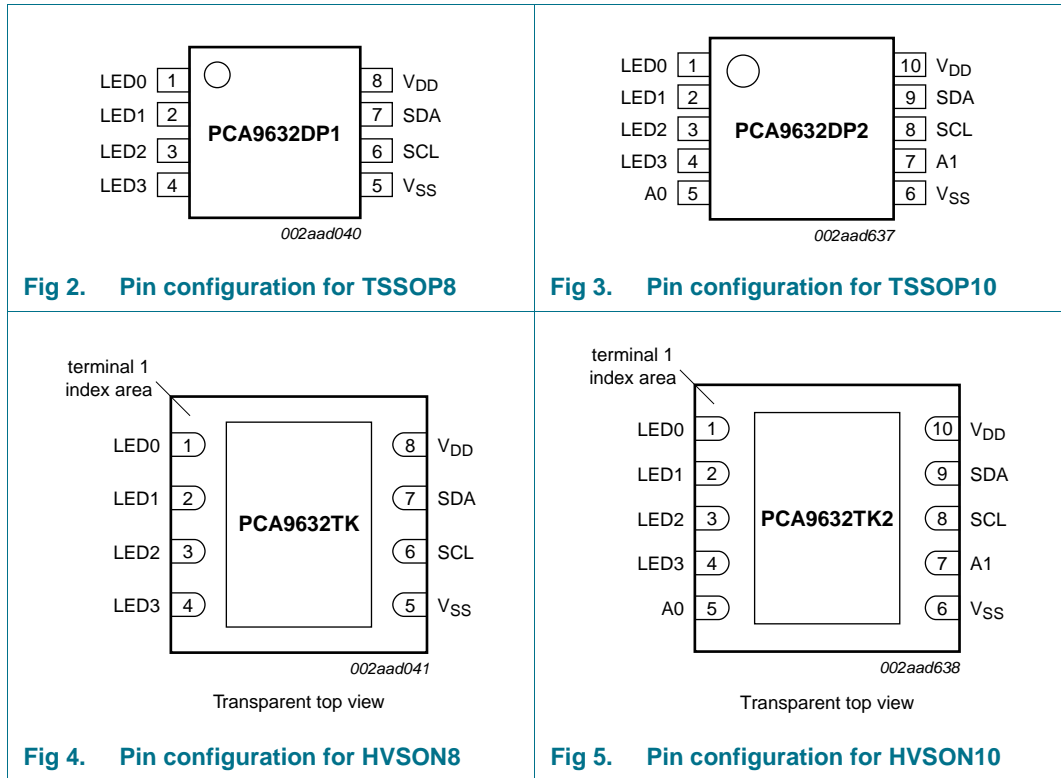

Fig 1. Block diagram of PCA9632

6. Pinning information

6.1 Pinning



6.2 Pin description

Table 2. Pin description for TSSOP8 and HVSON8

| Symbol | Pin | Type | Description |
|-----------------|------------------|--------------|-------------------|
| LED0 | 1 | O | LED driver 0 |
| LED1 | 2 | O | LED driver 1 |
| LED2 | 3 | O | LED driver 2 |
| LED3 | 4 | O | LED driver 3 |
| V _{SS} | 5 ^[1] | power supply | supply ground |
| SCL | 6 | I | serial clock line |
| SDA | 7 | I/O | serial data line |
| V _{DD} | 8 | power supply | supply voltage |

[1] HVSON8 package die supply ground is connected to both the V_{SS} pin and the exposed center pad. The V_{SS} pin must be connected to supply ground for proper device operation. For enhanced thermal, electrical, and board-level performance, the exposed pad needs to be soldered to the board using a corresponding thermal pad on the board, and for proper heat conduction through the board thermal vias need to be incorporated in the PCB in the thermal pad region.

Table 3. Pin description for TSSOP10 and HVSON10

| Symbol | Pin | Type | Description |
|-----------------|------------------|--------------|-------------------|
| LED0 | 1 | O | LED driver 0 |
| LED1 | 2 | O | LED driver 1 |
| LED2 | 3 | O | LED driver 2 |
| LED3 | 4 | O | LED driver 3 |
| A0 | 5 | I | address input 0 |
| V _{SS} | 6 ^[1] | power supply | supply ground |
| A1 | 7 | I | address input 1 |
| SCL | 8 | I | serial clock line |
| SDA | 9 | I/O | serial data line |
| V _{DD} | 10 | power supply | supply voltage |

[1] HVSON10 package die supply ground is connected to both the V_{SS} pin and the exposed center pad. The V_{SS} pin must be connected to supply ground for proper device operation. For enhanced thermal, electrical, and board-level performance, the exposed pad needs to be soldered to the board using a corresponding thermal pad on the board, and for proper heat conduction through the board thermal vias need to be incorporated in the PCB in the thermal pad region.

7. Functional description

Refer to [Figure 1 “Block diagram of PCA9632”](#).

7.1 Device addresses

Following a START condition, the bus master must output the address of the slave it is accessing.

There are a maximum of 4 possible programmable addresses using the 2 hardware address pins for the 10-pin version and just one fixed address for the 8-pin version.

7.1.1 Regular I²C-bus slave address

The I²C-bus slave address of the PCA9632 is shown in [Figure 6](#). To conserve power, no internal pull-up resistors are incorporated on the hardware selectable address pins and they must be pulled HIGH or LOW (10-pin versions only).

Remark: Using reserved I²C-bus addresses will interfere with other devices, but only if the devices are on the bus and/or the bus will be open to other I²C-bus systems at some later date. In a closed system where the designer controls the address assignment these addresses can be used since the PCA9632 treats them like any other address. The LED All Call, Software Reset and PCA9564 or PCA9665 slave address (if on the bus) can never be used for individual device addresses.

- PCA9632 LED All Call address (1110 000) or Software Reset (0000 0110) which are active on start-up
- PCA9564 (0000 000) or PCA9665 (1110 000) slave address which is active on start-up
- ‘reserved for future use’ I²C-bus addresses (0000 011, 1111 1XX)
- slave devices that use the 10-bit addressing scheme (1111 0XX)

- slave devices that are designed to respond to the General Call address (0000 000)
- High-speed mode (Hs-mode) master code (0000 1XX)

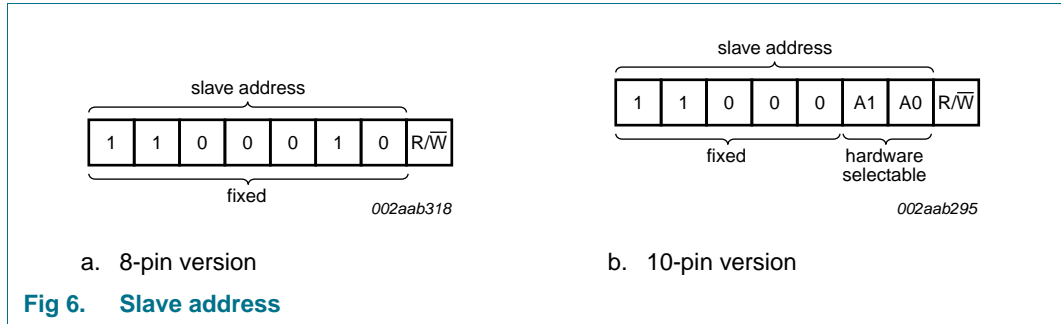

The last bit of the address byte defines the operation to be performed. When set to logic 1 a read is selected, while a logic 0 selects a write operation.

7.1.2 LED All Call I²C-bus address

- Default power-up value (ALLCALLADR register): E0h or 1110 000
- Programmable through I²C-bus (volatile programming)
- At power-up, LED All Call I²C-bus address is enabled. PCA9632 sends an ACK when E0h (R/W = 0) or E1h (R/W = 1) is sent by the master.

See [Section 7.3.8 “LED All Call I²C-bus address, ALLCALLADR”](#) for more detail.

Remark: The default LED All Call I²C-bus address (E0h or 1110 000) must not be used as a regular I²C-bus slave address since this address is enabled at power-up. All the PCA9632s on the I²C-bus will acknowledge the address if sent by the I²C-bus master.

7.1.3 LED Sub Call I²C-bus addresses

- 3 different I²C-bus addresses can be used
- Default power-up values:
 - SUBADR1 register: E2h or 1110 001
 - SUBADR2 register: E4h or 1110 010
 - SUBADR3 register: E8h or 1110 100
- Programmable through I²C-bus (volatile programming)
- At power-up, Sub Call I²C-bus addresses are disabled. PCA9632 does not send an ACK when E2h (R/W = 0) or E3h (R/W = 1), E4h (R/W = 0) or E5h (R/W = 1), or E8h (R/W = 0) or E9h (R/W = 1) is sent by the master.

See [Section 7.3.7 “I²C-bus subaddress 1 to 3, SUBADR_x”](#) for more detail.

Remark: The default LED Sub Call I²C-bus addresses may be used as regular I²C-bus slave addresses as long as they are disabled.

7.1.4 Software reset I²C-bus address

The address shown in [Figure 7](#) is used when a reset of the PCA9632 needs to be performed by the master. The Software Reset address (SWRST Call) must be used with $R/\overline{W} = 0$. If $R/\overline{W} = 1$, the PCA9632 does not acknowledge the SWRST. See [Section 7.5 “Software reset”](#) for more detail.

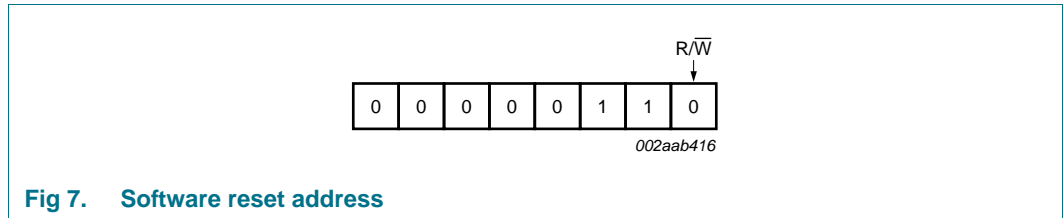

Fig 7. Software reset address

Remark: The Software Reset I²C-bus address is a reserved address and cannot be used as a regular I²C-bus slave address or as an LED All Call or LED Sub Call address.

7.2 Control register

Following the successful acknowledgement of the slave address, LED All Call address or LED Sub Call address, the bus master will send a byte to the PCA9632, which will be stored in the Control register.

The lowest 4 bits are used as a pointer to determine which register will be accessed (D[3:0]). The highest 3 bits are used as Auto-Increment flag and Auto-Increment options (AI[2:0]). Bit 4 is unused and must be programmed with zero (0) for proper device operation.

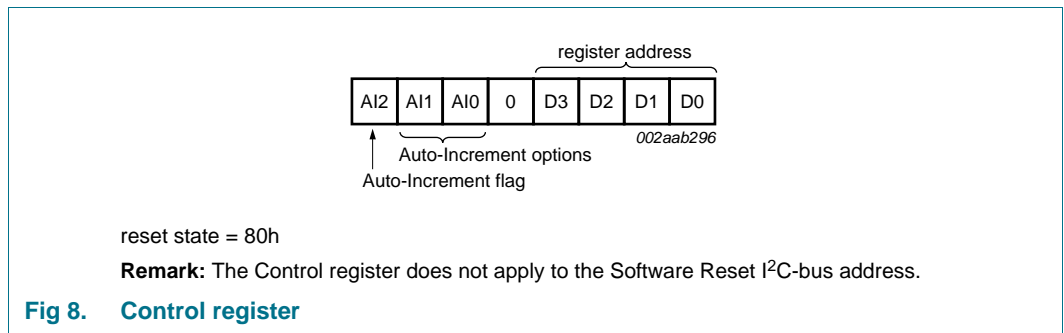

Fig 8. Control register

When the Auto-Increment flag is set (AI2 = 1), the four low order bits of the Control register are automatically incremented after a read or write. This allows the user to program the registers sequentially. Four different types of Auto-Increment are possible, depending on AI1 and AI0 values.

Table 4. Auto-Increment options

| AI2 | AI1 | AI0 | Function |
|-----|-----|-----|---|
| 0 | 0 | 0 | no Auto-Increment |
| 1 | 0 | 0 | Auto-Increment for all registers. D3, D2, D1, D0 roll over to '0000' after the last register (1100) is accessed. |
| 1 | 0 | 1 | Auto-Increment for Individual brightness registers only. D3, D2, D1, D0 roll over to '0010' after the last register (0101) is accessed. |
| 1 | 1 | 0 | Auto-Increment for global control registers only. D3, D2, D1, D0 roll over to '0110' after the last register (0111) is accessed. |
| 1 | 1 | 1 | Auto-Increment for individual and global control registers only. D3, D2, D1, D0 roll over to '0010' after the last register (0111) is accessed. |

Remark: Other combinations not shown in [Table 4](#) (AI[2:0] = 001, 010, and 011) are reserved and must not be used for proper device operation.

AI[2:0] = 000 is used when the same register must be accessed several times during a single I²C-bus communication, for example, changes the brightness of a single LED. Data is overwritten each time the register is accessed during a write operation.

AI[2:0] = 100 is used when all the registers must be sequentially accessed, for example, power-up programming.

AI[2:0] = 101 is used when the four LED drivers must be individually programmed with different values during the same I²C-bus communication, for example, changing color setting to another color setting.

AI[2:0] = 110 is used when the LED drivers must be globally programmed with different settings during the same I²C-bus communication, for example, global brightness or blinking change.

AI[2:0] = 111 is used when individual and global changes must be performed during the same I²C-bus communication, for example, changing a color and global brightness at the same time.

Only the 4 least significant bits D[3:0] are affected by the AI[2:0] bits.

When the Control register is written, the register entry point determined by D[3:0] is the first register that will be addressed (read or write operation), and can be anywhere between 0000 and 1100 (as defined in [Table 5](#)). When AI[2] = 1, the Auto-Increment flag is set and the rollover value at which the point where the register increment stops and goes to the next one is determined by AI[2:0]. See [Table 4](#) for rollover values. For example, if the Control register = 1110 1000 (E8h), then the register addressing sequence will be (in hex):

08 → ... → 0C → 00 → ... → 07 → 02 → ... → 07 → 02 → ... → 07 → 02 → ... as long as the master keeps sending or reading data.

7.3 Register definitions

Table 5. Register summary

Only D[3:0] = 0000 to 1100 are allowed and will be acknowledged. D[3:0] = 1101, 1110, or 1111 are reserved and will not be acknowledged.

When writing to the Control register, bit 4 must be programmed with logic 0 for proper device operation.

| Register number (hex) | D3 | D2 | D1 | D0 | Name | Type | Function |
|-----------------------|----|----|----|----|------------|------------|---|
| 00h | 0 | 0 | 0 | 0 | MODE1 | read/write | Mode register 1 |
| 01h | 0 | 0 | 0 | 1 | MODE2 | read/write | Mode register 2 |
| 02h | 0 | 0 | 1 | 0 | PWM0 | read/write | brightness control LED0 |
| 03h | 0 | 0 | 1 | 1 | PWM1 | read/write | brightness control LED1 |
| 04h | 0 | 1 | 0 | 0 | PWM2 | read/write | brightness control LED2 |
| 05h | 0 | 1 | 0 | 1 | PWM3 | read/write | brightness control LED3 |
| 06h | 0 | 1 | 1 | 0 | GRPPWM | read/write | group duty cycle control |
| 07h | 0 | 1 | 1 | 1 | GRPFREQ | read/write | group frequency |
| 08h | 1 | 0 | 0 | 0 | LEDOUT | read/write | LED output state |
| 09h | 1 | 0 | 0 | 1 | SUBADR1 | read/write | I ² C-bus subaddress 1 |
| 0Ah | 1 | 0 | 1 | 0 | SUBADR2 | read/write | I ² C-bus subaddress 2 |
| 0Bh | 1 | 0 | 1 | 1 | SUBADR3 | read/write | I ² C-bus subaddress 3 |
| 0Ch | 1 | 1 | 0 | 0 | ALLCALLADR | read/write | LED All Call I ² C-bus address |

7.3.1 Mode register 1, MODE1

Table 6. MODE1 - Mode register 1 (address 00h) bit description

Legend: * default value.

| Bit | Symbol | Access | Value | Description |
|-----|---------|-----------|-------|--|
| 7 | AI2 | read only | 0 | Register Auto-Increment disabled |
| | | | 1* | Register Auto-Increment enabled |
| 6 | AI1 | read only | 0* | Auto-Increment bit 1 = 0 |
| | | | 1 | Auto-Increment bit 1 = 1 |
| 5 | AI0 | read only | 0* | Auto-Increment bit 0 = 0 |
| | | | 1 | Auto-Increment bit 0 = 1 |
| 4 | SLEEP | R/W | 0 | Normal mode ^[1] . |
| | | | 1* | Low power mode. Oscillator off ^[2] . |
| 3 | SUB1 | R/W | 0* | PCA9632 does not respond to I ² C-bus subaddress 1. |
| | | | 1 | PCA9632 responds to I ² C-bus subaddress 1. |
| 2 | SUB2 | R/W | 0* | PCA9632 does not respond to I ² C-bus subaddress 2. |
| | | | 1 | PCA9632 responds to I ² C-bus subaddress 2. |
| 1 | SUB3 | R/W | 0* | PCA9632 does not respond to I ² C-bus subaddress 3. |
| | | | 1 | PCA9632 responds to I ² C-bus subaddress 3. |
| 0 | ALLCALL | R/W | 0 | PCA9632 does not respond to LED All Call I ² C-bus address. |
| | | | 1* | PCA9632 responds to LED All Call I ² C-bus address. |

[1] It takes 500 μ s max. for the oscillator to be up and running once SLEEP bit has been set to logic 0. Timings on LEDn outputs are not guaranteed if PWMx, GRPPWM or GRPFREQ registers are accessed within the 500 μ s window.

[2] When the oscillator is off (Sleep mode), the LED outputs cannot be turned on, off or dimmed/blinked.

7.3.2 Mode register 2, MODE2

Table 7. MODE2 - Mode register 2 (address 01h) bit description

Legend: * default value.

| Bit | Symbol | Access | Value | Description |
|--------|-----------------------|-----------|-------|---|
| 7 | - | read only | 0* | reserved |
| 6 | - | read only | 0* | reserved |
| 5 | DMBLNK | R/W | 0* | Group control = dimming |
| | | | 1 | Group control = blinking |
| 4 | INVRT ^[1] | R/W | 0* | Output logic state not inverted. Value to use when no external driver used. |
| | | | 1 | Output logic state inverted. Value to use when external driver used. |
| 3 | OCH | R/W | 0* | Outputs change on STOP command ^[2] |
| | | | 1 | Outputs change on ACK. |
| 2 | OUTDRV ^[1] | R/W | 0* | The 4 LED outputs are configured with an open-drain structure. |
| | | | 1 | The 4 LED outputs are configured with a totem pole structure. |
| 1 to 0 | OUTNE[1:0] | R/W | 01* | unused |

[1] See [Section 7.6 "Using the PCA9632 with and without external drivers"](#) for more details. Normal LEDs can be driven directly in either mode. Some newer LEDs include integrated Zener diodes to limit voltage transients, reduce EMI, protect the LEDs, and these must be driven only in the open-drain mode to prevent overheating the IC.

[2] Change of the outputs at the STOP command allows synchronizing outputs of more than one PCA9632. Applicable to registers from 02h (PWM0) to 08h (LEDOUT) only.

7.3.3 PWM registers 0 to 3, PWMx — Individual brightness control registers

Table 8. PWM0 to PWM3 - PWM registers 0 to 3 (address 02h to 05h) bit description
 Legend: * default value.

| Address | Register | Bit | Symbol | Access | Value | Description |
|---------|----------|-----|-----------|--------|------------|----------------------------|
| 02h | PWM0 | 7:0 | IDC0[7:0] | R/W | 0000 0000* | PWM0 Individual Duty Cycle |
| 03h | PWM1 | 7:0 | IDC1[7:0] | R/W | 0000 0000* | PWM1 Individual Duty Cycle |
| 04h | PWM2 | 7:0 | IDC2[7:0] | R/W | 0000 0000* | PWM2 Individual Duty Cycle |
| 05h | PWM3 | 7:0 | IDC3[7:0] | R/W | 0000 0000* | PWM3 Individual Duty Cycle |

While operating in Individual brightness mode (LDRx = 10), a 1.5625 kHz fixed frequency signal is used for each output. Duty cycle is controlled through 256 linear steps from 00h (0 % duty cycle = LED output off) to FFh (99.6 % duty cycle = LED output at maximum brightness). In this mode, all the 8 bits are used.

$$duty\ cycle = \frac{IDC_x[7:0]}{256} \tag{1}$$

E.g., if IDCx[7:0] = 1111 1111, then duty cycle = 255 / 256 = 99.6 %.

While operating in group dimming mode, a 6.25 kHz fixed frequency signal is used for each output. Duty cycle is controlled through 64 linear steps from 00h (0 % duty cycle = LED output off) to 3Fh (98.4 % duty cycle = LED output at maximum brightness). In this mode only the 6 MSBs are used (IDCx[7:2]). The 2 LSBs IDCx[1:0] are ignored. Applicable to LED outputs programmed with LDRx = 11 (LEDOUT register).

$$duty\ cycle = \frac{IDC_x[7:2],00}{256} \tag{2}$$

E.g., if IDCx[7:2] = 111111, then duty cycle = 1111 1100 / 256 = 252 / 256 = 98.4 %.

While operating in blink mode, a 1.5625 kHz fixed frequency signal is used for each output. Duty cycle is controlled through 256 linear steps from 00h (0 % duty cycle = LED output off) to FFh (99.6 % duty cycle = LED output at maximum brightness). In this mode, all the 8 bits are used.

$$duty\ cycle = \frac{IDC_x[7:0]}{256} \tag{3}$$

E.g., if IDCx[7:0] = 1111 1111, then duty cycle = 255 / 256 = 99.6 %.

Applicable to LED outputs programmed with LDRx = 11 (LEDOUT register).

7.3.4 Group duty cycle control, GRPPWM

Table 9. GRPPWM - Group duty cycle control register (address 06h) bit description
 Legend: * default value.

| Address | Register | Bit | Symbol | Access | Value | Description |
|---------|----------|-----|----------|--------|-----------|-----------------|
| 06h | GRPPWM | 7:0 | GDC[7:0] | R/W | 1111 1111 | GRPPWM register |

When DMBLNK bit (MODE2 register) is programmed with 0, a 190 Hz fixed frequency signal is superimposed with the 6.25 kHz Individual brightness control signal. GRPPWM is then used as a global brightness control allowing the LED outputs to be dimmed with the same value. The value in GRPFREQ is then a ‘don’t care’.

In the group dimming mode (DMBLNK = 0) global brightness for the 4 outputs is controlled through 16 linear steps from 00h (0 % duty cycle = LED output off) to F0h (93.75 % duty cycle = maximum brightness). In this mode only the 4 MSBs of the GRPPWM[7:4] are used. Bits GRPPWM[3:0] are unused.

$$duty\ cycle = \frac{GDC[7:4],0000}{256} \tag{4}$$

E.g., if GDC[7:4] = 1111, then duty cycle = 1111 0000 / 256 = 240 / 256 = 93.75 %.

When DMBLNK bit is programmed with 1, GRPPWM and GRPFREQ registers define a global blinking pattern, where GRPFREQ contains the blinking period (from 24 Hz to 10.73 s) and GRPPWM the duty cycle (ON/OFF ratio in %).

In this mode, when GRPFREQ is programmed to provide a blinking with frequency programmable from 24 Hz to 6 Hz, GRPPWM[7:2] is used to provide 64-step duty cycle resolution from 0 % to 98.4 %. GRPPWM[1:0] bits are unused.

$$duty\ cycle = \frac{GDC[7:2],00}{256} \tag{5}$$

E.g., if GDC[7:2] = 111111, then duty cycle = 1111 1100 / 256 = 252 / 256 = 98.4 %.

When GRPFREQ is programmed to provide a blinking with frequency programmable from 6 Hz to 0.09 Hz (10.73 s), GRPPWM[7:0] is used to provide a 256-step duty cycle resolution from 0 % to 99.6 %. In this case, all the 8 bits of the GRPPWM register are used.

$$duty\ cycle = \frac{GDC[7:0]}{256} \tag{6}$$

E.g., if GDC[7:0] = 1111 1111, then duty cycle = 255 / 256 = 99.6 %.

Applicable to LED outputs programmed with LDRx = 11 (LEDOUT register).

7.3.5 Group frequency, GRPFREQ

Table 10. GRPFREQ - Group frequency register (address 07h) bit description

Legend: * default value.

| Address | Register | Bit | Symbol | Access | Value | Description |
|---------|----------|-----|-----------|--------|------------|------------------|
| 07h | GRPFREQ | 7:0 | GFRQ[7:0] | R/W | 0000 0000* | GRPFREQ register |

GRPFREQ is used to program the global blinking period when DMBLNK bit (MODE2 register) is equal to logic 1. Value in this register is a 'don't care' when DMBLNK = 0. Applicable to LED outputs programmed with LDRx = 11 (LEDOUT register).

Blinking period is controlled through 256 linear steps from 00h (41 ms, frequency 24 Hz) to FFh (10.73 seconds).

$$global\ blinking\ period = \frac{GFRQ[7:0] + 1}{24} \text{ (in seconds)} \tag{7}$$

7.3.6 LED driver output state, LEDOUT

Table 11. LEDOUT - LED driver output state register (address 08h) bit description

Legend: * default value.

| Address | Register | Bit | Symbol | Access | Value | Description |
|---------|----------|-----|--------|--------|-------|---------------------------|
| 08h | LEDOUT | 7:6 | LDR3 | R/W | 00* | LED3 output state control |
| | | 5:4 | LDR2 | R/W | 00* | LED2 output state control |
| | | 3:2 | LDR1 | R/W | 00* | LED1 output state control |
| | | 1:0 | LDR0 | R/W | 00* | LED0 output state control |

LDRx = 00 — LED driver x is off (default power-up state).

LDRx = 01 — LED driver x is fully on (individual brightness and group dimming/blinking not controlled).

LDRx = 10 — LED driver x individual brightness can be controlled through its PWMx register.

LDRx = 11 — LED driver x individual brightness and group dimming/blinking can be controlled through its PWMx register and the GRPPWM registers.

7.3.7 I²C-bus subaddress 1 to 3, SUBADRx

Table 12. SUBADR1 to SUBADR3 - I²C-bus subaddress registers 0 to 3 (address 09h to 0Bh) bit description

Legend: * default value.

| Address | Register | Bit | Symbol | Access | Value | Description |
|---------|----------|-----|---------|--------|-----------|-----------------------------------|
| 09h | SUBADR1 | 7:1 | A1[7:1] | R/W | 1110 001* | I ² C-bus subaddress 1 |
| | | 0 | A1[0] | R only | 0* | reserved |
| 0Ah | SUBADR2 | 7:1 | A2[7:1] | R/W | 1110 010* | I ² C-bus subaddress 2 |
| | | 0 | A2[0] | R only | 0* | reserved |
| 0Bh | SUBADR3 | 7:1 | A3[7:1] | R/W | 1110 100* | I ² C-bus subaddress 3 |
| | | 0 | A3[0] | R only | 0* | reserved |

Subaddresses are programmable through the I²C-bus. Default power-up values are E2h, E4h, E8h, and the device(s) will not acknowledge these addresses right after power-up (the corresponding SUBx bit in MODE1 register is equal to logic 0).

Once subaddresses have been programmed to their right values, SUBx bits need to be set to 1 in order to have the device acknowledging these addresses (MODE1 register).

Only the 7 MSBs representing the I²C-bus subaddress are valid. The LSB in SUBADR_x register is a read-only bit (0).

When SUBx is set to 1, the corresponding I²C-bus subaddress can be used during either an I²C-bus read or write sequence.

7.3.8 LED All Call I²C-bus address, ALLCALLADR

Table 13. ALLCALLADR - LED All Call I²C-bus address register (address 0Ch) bit description

Legend: * default value.

| Address | Register | Bit | Symbol | Access | Value | Description |
|---------|------------|-----|---------|--------|-----------|---|
| 0Ch | ALLCALLADR | 7:1 | AC[7:1] | R/W | 1110 000* | ALLCALL I ² C-bus address register |
| | | 0 | AC[0] | R only | 0* | reserved |

The LED All Call I²C-bus address allows all the PCA9632s in the bus to be programmed at the same time (ALLCALL bit in register MODE1 must be equal to 1, power-up default state). This address is programmable through the I²C-bus and can be used during either an I²C-bus read or write sequence. The register address can be programmed as a sub call.

Only the 7 MSBs representing the All Call I²C-bus address are valid. The LSB in ALLCALLADR register is a read-only bit (0).

If ALLCALL bit = 0, the device does not acknowledge the address programmed in register ALLCALLADR.

7.4 Power-on reset

When power is applied to V_{DD}, an internal power-on reset holds the PCA9632 in a reset condition until V_{DD} has reached V_{POR}. At this point, the reset condition is released and the PCA9632 registers and I²C-bus state machine are initialized to their default states (all zeroes) causing all the channels to be deselected. Thereafter, V_{DD} must be lowered below 0.2 V to reset the device.

7.5 Software reset

The Software Reset Call (SWRST Call) allows all the devices in the I²C-bus to be reset to the power-up state value through a specific formatted I²C-bus command. To be performed correctly, it implies that the I²C-bus is functional and that there is no device hanging the bus.

The SWRST Call function is defined as the following:

1. A START command is sent by the I²C-bus master.
2. The reserved SWRST I²C-bus address '0000 011' with the R/W bit set to 0 (write) is sent by the I²C-bus master.
3. The PCA9632 device(s) acknowledge(s) after seeing the SWRST Call address '0000 0110' (06h) only. If the R/W bit is set to 1 (read), no acknowledge is returned to the I²C-bus master.

4. Once the SWRST Call address has been sent and acknowledged, the master sends 2 bytes with 2 specific values (SWRST data byte 1 and byte 2):
 - a. Byte 1 = A5h: the PCA9632 acknowledges this value only. If byte 1 is not equal to A5h, the PCA9632 does not acknowledge it.
 - b. Byte 2 = 5Ah: the PCA9632 acknowledges this value only. If byte 2 is not equal to 5Ah, then the PCA9632 does not acknowledge it.

If more than 2 bytes of data are sent, the PCA9632 does not acknowledge any more.
5. Once the right 2 bytes (SWRST data byte 1 and byte 2 only) have been sent and correctly acknowledged, the master sends a STOP command to end the SWRST Call: the PCA9632 then resets to the default value (power-up value) and is ready to be addressed again within the specified bus free time (t_{BUF}).

The I²C-bus master must interpret a non-acknowledge from the PCA9632 (at any time) as a 'SWRST Call Abort'. The PCA9632 does not initiate a reset of its registers. This happens only when the format of the SWRST Call sequence is not correct.

7.6 Using the PCA9632 with and without external drivers

The PCA9632 LED output drivers are 5.5 V only tolerant and can sink up to 25 mA at 5 V.

If the device needs to drive LEDs to a higher voltage and/or higher current, use of an external driver is required.

- INVRT bit (MODE2 register) can be used to keep the LED PWM control firmware the same (PWMx and GRPPWM values directly calculated from their respective formulas and the LED output state determined by LEDOUT register value) independently of the type of external driver.
- OUTDRV bit (MODE2 register) allows minimizing the amount of external components required to control the external driver (N-type or P-type device).

Table 14. Use of INVRT and OUTDRV based on connection to the LEDn outputs

| INVRT | OUTDRV | Direct connection to LEDn | | External N-type driver | | External P-type driver | |
|-------|--------|---|---------------------------------------|---|-----------------------------|---|-----------------------------|
| | | Firmware | External pull-up resistor | Firmware | External pull-up resistor | Firmware | External pull-up resistor |
| 0 | 0 | formulas and LED output state values apply ^[1] | LED current limiting R ^[1] | formulas and LED output state values inverted | required | formulas and LED output state values apply | required |
| 0 | 1 | formulas and LED output state values apply ^[1] | LED current limiting R ^[1] | formulas and LED output state values inverted | not required | formulas and LED output state values apply ^[3] | not required ^[3] |
| 1 | 0 | formulas and LED output state values inverted | LED current limiting R | formulas and LED output state values apply | required | formulas and LED output state values inverted | required |
| 1 | 1 | formulas and LED output state values inverted | LED current limiting R | formulas and LED output state values apply ^[2] | not required ^[2] | formulas and LED output state values inverted | not required |

[1] Correct configuration when LEDs directly connected to the LEDn outputs (connection to V_{DD} through current limiting resistor).

[2] Optimum configuration when external N-type (NPN, NMOS) driver used.

[3] Optimum configuration when external P-type (PNP, PMOS) driver used.

Table 15. Output transistors based on LEDOUT registers, INVRT and OUTDRV bits

| LEDOUT | INVRT | OUTDRV | Upper transistor (V _{DD} to LEDn) | Lower transistor (LEDn to V _{SS}) | LEDn state |
|---|-------|--------|--|---|--|
| 00 | 0 | 0 | off | off | high-Z ^[1] |
| LED driver off | 0 | 1 | on | off | V _{DD} |
| | 1 | 0 | off | on | V _{SS} |
| | 1 | 1 | off | on | V _{SS} |
| 01 | 0 | 0 | off | on | V _{SS} |
| LED driver on | 0 | 1 | off | on | V _{SS} |
| | 1 | 0 | off | off | high-Z ^[1] |
| | 1 | 1 | on | off | V _{DD} |
| 10 Individual brightness control | 0 | 0 | off | Individual PWM (non-inverted) | V _{SS} or high-Z ^[1] = PWMx value |
| | 0 | 1 | Individual PWM (non-inverted) | Individual PWM (non-inverted) | V _{SS} or V _{DD} = PWMx value |
| | 1 | 0 | off | Individual PWM (inverted) | high-Z ^[1] or V _{SS} = 1 – PWMx value |
| | 1 | 1 | Individual PWM (inverted) | Individual PWM (inverted) | V _{DD} or V _{SS} = 1 – PWMx value |
| 11 Individual + group dimming/ blinking | 0 | 0 | off | Individual + Group PWM (non-inverted) | V _{SS} or high-Z ^[1] = PWMx/GRPPWM values |
| | 0 | 1 | Individual PWM (non-inverted) | Individual PWM (non-inverted) | V _{SS} or V _{DD} = PWMx/GRPPWM values |
| | 1 | 0 | off | Individual + Group PWM (inverted) | high-Z ^[1] or V _{SS} = (1 – PWMx) or (1 – GRPPWM) values |
| | 1 | 1 | Individual PWM (inverted) | Individual PWM (inverted) | V _{DD} or V _{SS} = (1 – PWMx) or (1 – GRPPWM) values |

[1] External pull-up or LED current limiting resistor connects LEDn to V_{DD}.

7.7 Individual brightness control with group dimming/blinking

A 1.5625 kHz fixed frequency signal with programmable duty cycle (8 bits, 256 steps) is used to control individually the brightness for each LED.

On top of this signal, one of the following signals can be superimposed (this signal can be applied to the 4 LED outputs):

- A lower 190 Hz fixed frequency signal with programmable duty cycle (4 bits, 16 steps) is used to provide a global brightness control.
- A programmable frequency signal from 24 Hz to $\frac{1}{10.73}$ Hz (8 bits, 256 steps) with programmable duty cycle (6 bits, 64 steps) is used to provide a global blinking control for (24 Hz to 6 Hz) and (8 bits, 256 steps) for (6 Hz to $\frac{1}{10.73}$ Hz).

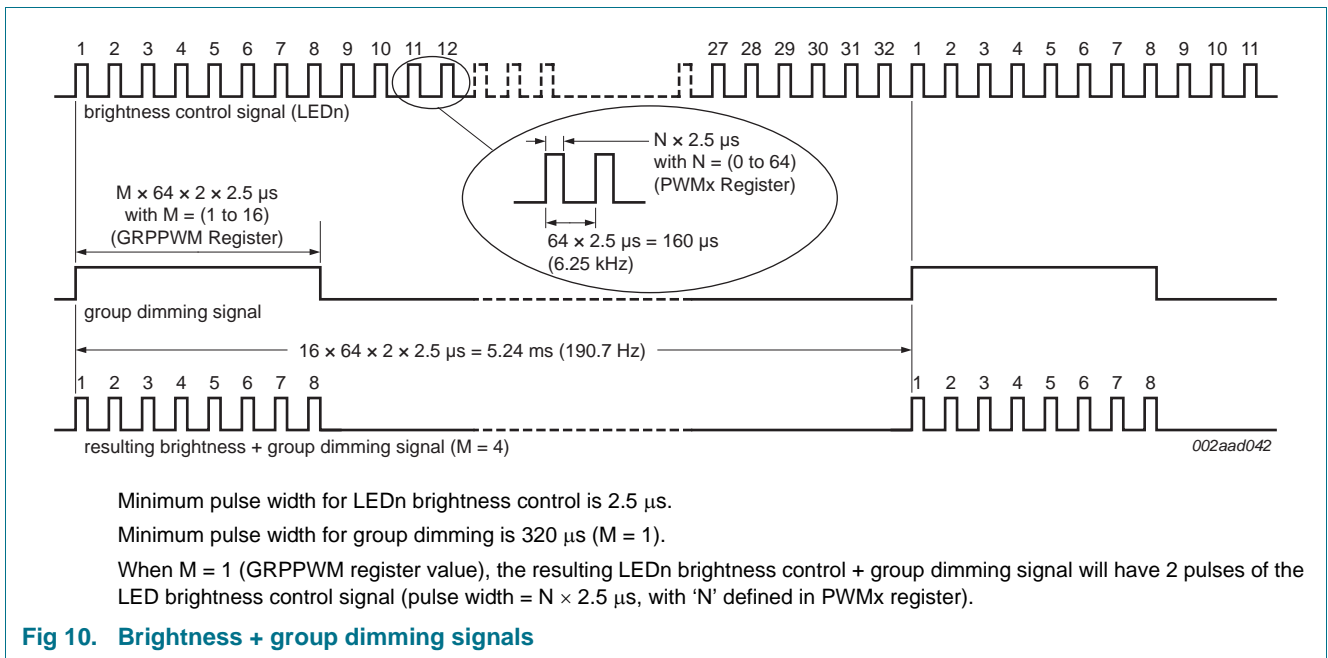
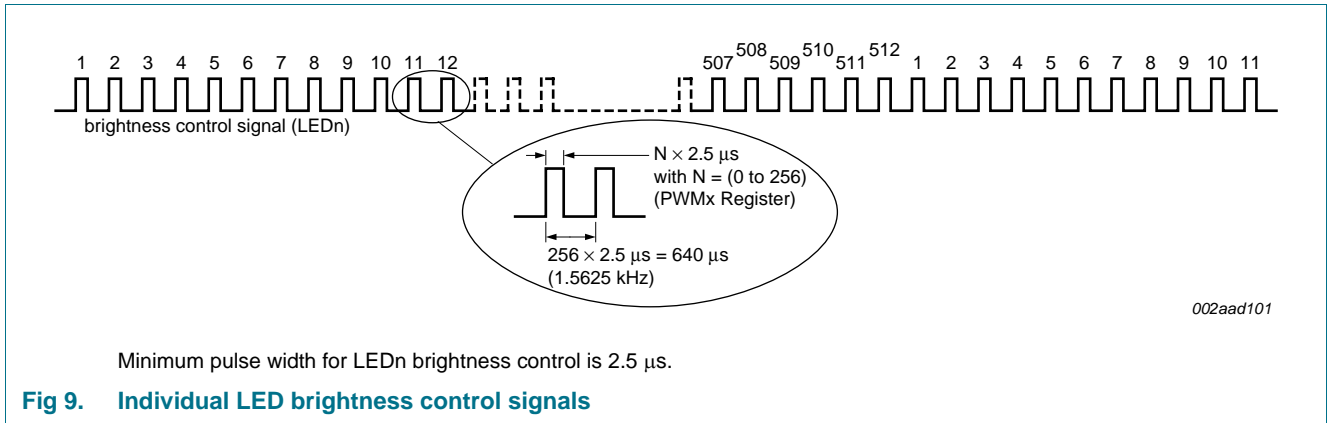

Table 16. Dimming and blinking resolution

| Type of control | LDRx | DMBLNK | GRPPWM | GRPFREQ | Frequency | PWMx |
|---|------|--------|-----------|-----------|--|-----------|
| Individual LED brightness without dimming | 10 | X | X | X | 1.5625 kHz | 256 steps |
| Individual LED brightness with global dimming | 11 | 0 | 16 steps | X | 190 Hz with 6.25 kHz modulation | 64 steps |
| Blinking (fast) | 11 | 1 | 64 steps | 256 steps | blink frequency = 6 Hz to 24 Hz PWMx frequency = 1.5625 kHz | 256 steps |
| Blinking (slow) | 11 | 1 | 256 steps | 256 steps | blink frequency = 0.09 Hz to 6 Hz PWMx frequency = 1.5625 kHz | 256 steps |

8. Characteristics of the I²C-bus

The I²C-bus is for 2-way, 2-line communication between different ICs or modules. The two lines are a serial data line (SDA) and a serial clock line (SCL). Both lines must be connected to a positive supply via a pull-up resistor when connected to the output stages of a device. Data transfer may be initiated only when the bus is not busy.

8.1 Bit transfer

One data bit is transferred during each clock pulse. The data on the SDA line must remain stable during the HIGH period of the clock pulse as changes in the data line at this time will be interpreted as control signals (see [Figure 11](#)).

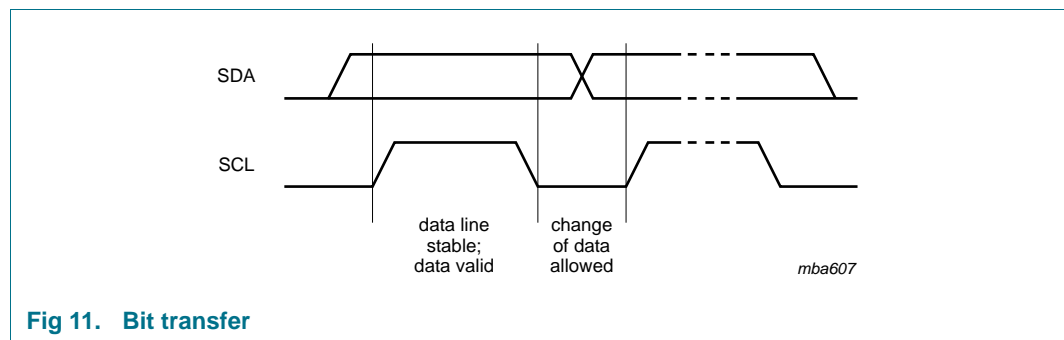

Fig 11. Bit transfer

8.1.1 START and STOP conditions

Both data and clock lines remain HIGH when the bus is not busy. A HIGH-to-LOW transition of the data line while the clock is HIGH is defined as the START condition (S). A LOW-to-HIGH transition of the data line while the clock is HIGH is defined as the STOP condition (P) (see [Figure 12](#)).

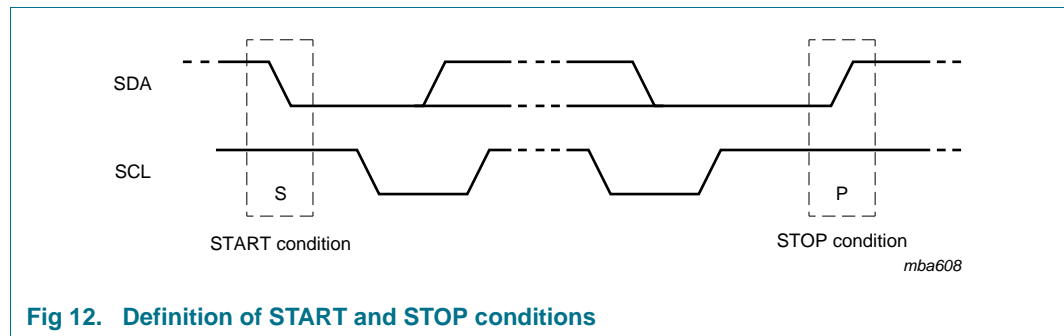

Fig 12. Definition of START and STOP conditions

8.2 System configuration

A device generating a message is a 'transmitter'; a device receiving is the 'receiver'. The device that controls the message is the 'master' and the devices which are controlled by the master are the 'slaves' (see [Figure 13](#)).

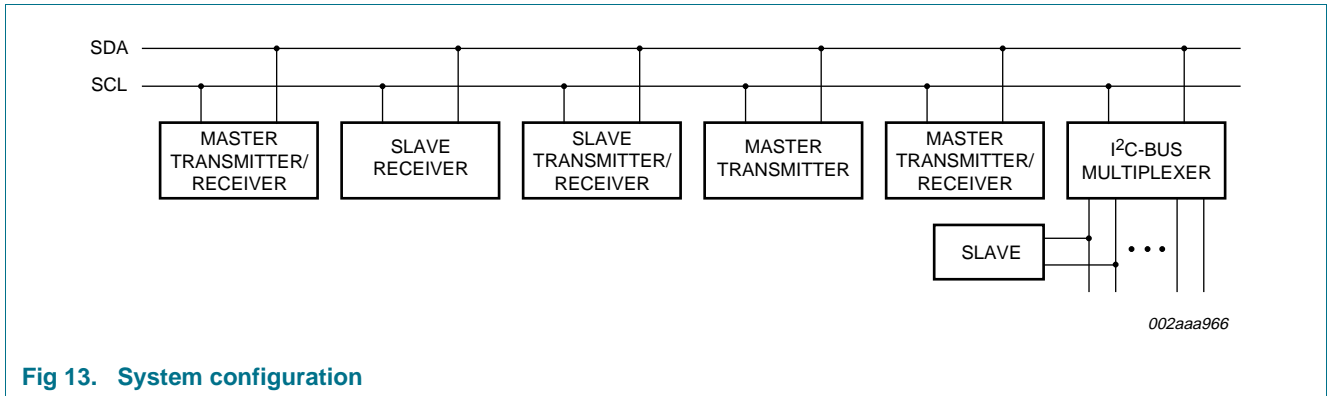

Fig 13. System configuration

8.3 Acknowledge

The number of data bytes transferred between the START and the STOP conditions from transmitter to receiver is not limited. Each byte of eight bits is followed by one acknowledge bit. The acknowledge bit is a HIGH level put on the bus by the transmitter, whereas the master generates an extra acknowledge related clock pulse.

A slave receiver which is addressed must generate an acknowledge after the reception of each byte. Also a master must generate an acknowledge after the reception of each byte that has been clocked out of the slave transmitter. The device that acknowledges has to pull down the SDA line during the acknowledge clock pulse, so that the SDA line is stable LOW during the HIGH period of the acknowledge related clock pulse; set-up time and hold time must be taken into account.

A master receiver must signal an end of data to the transmitter by not generating an acknowledge on the last byte that has been clocked out of the slave. In this event, the transmitter must leave the data line HIGH to enable the master to generate a STOP condition.

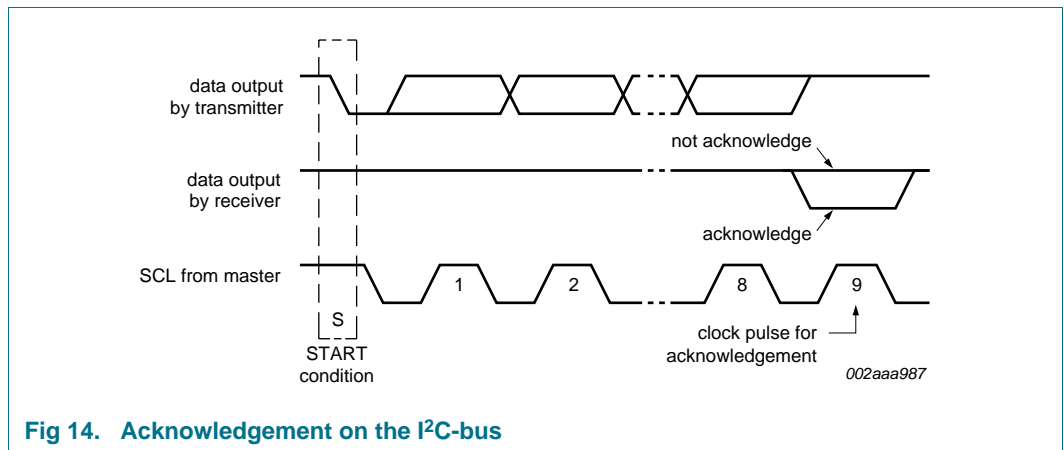
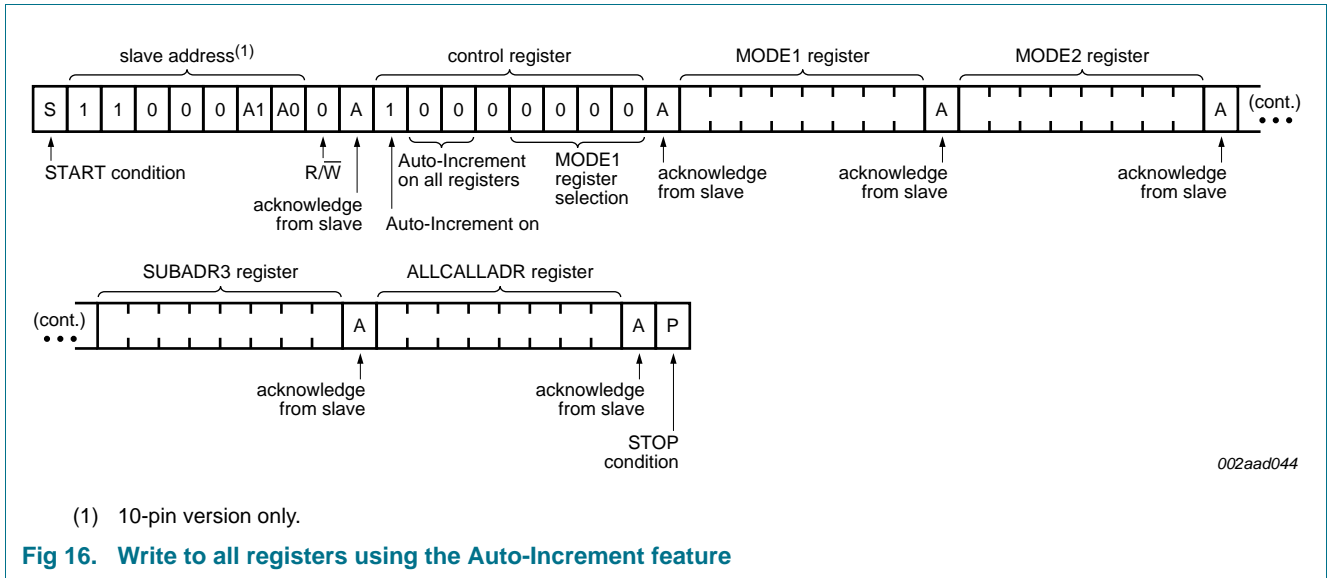
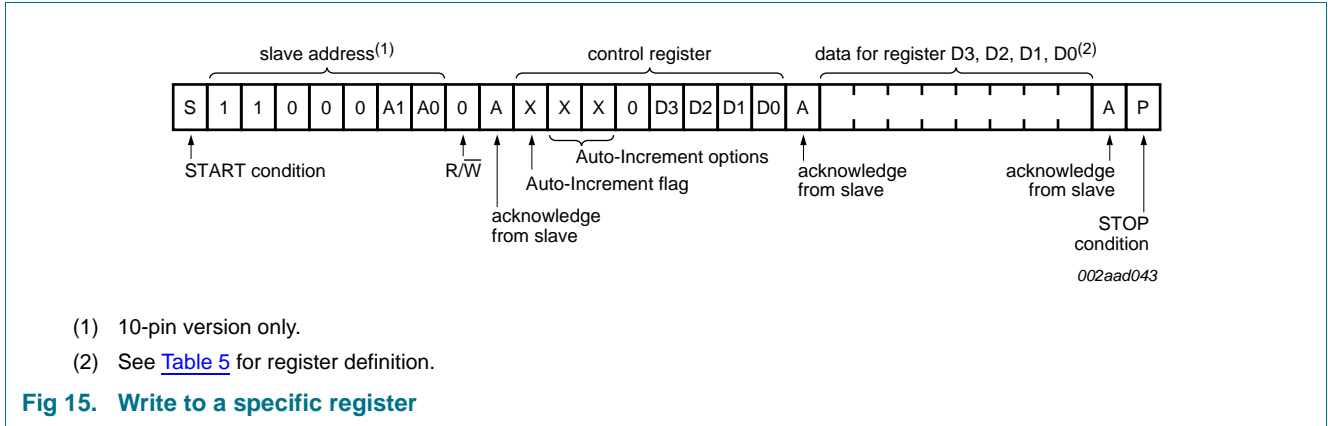
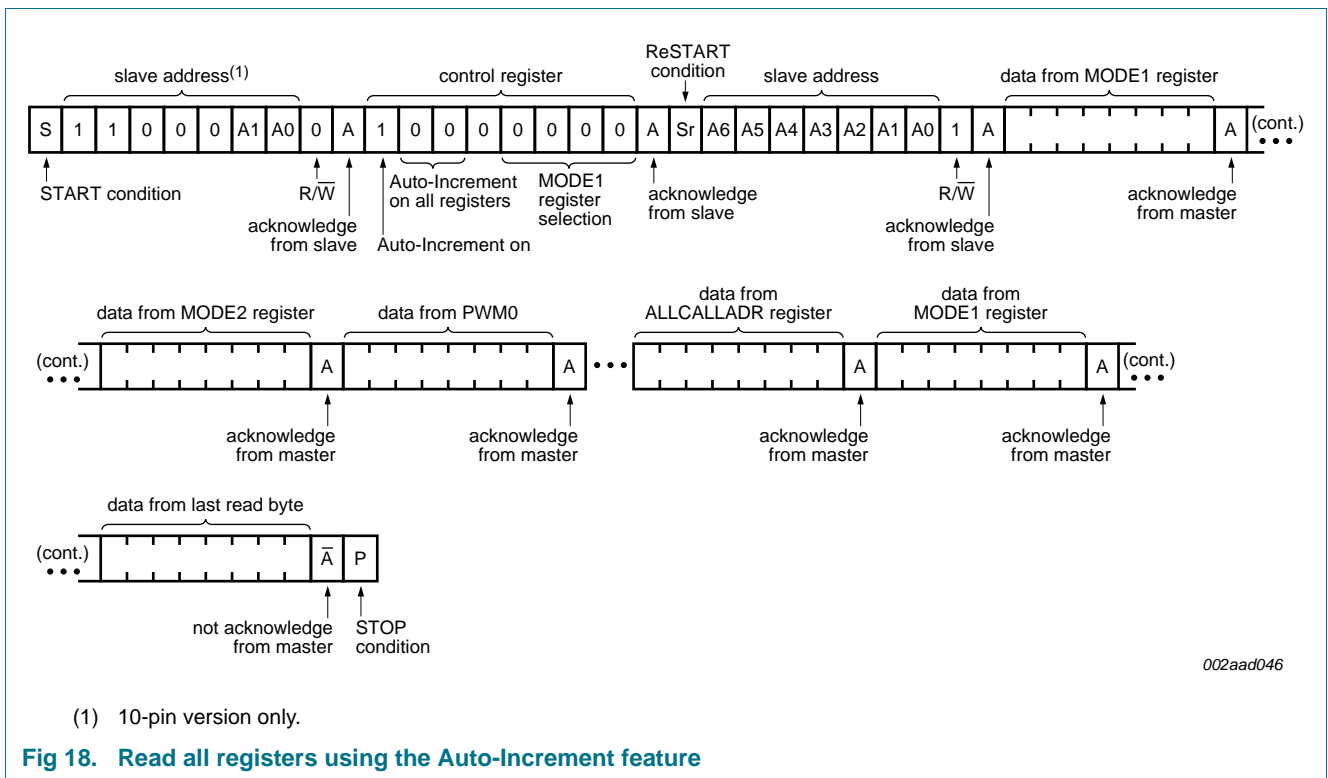
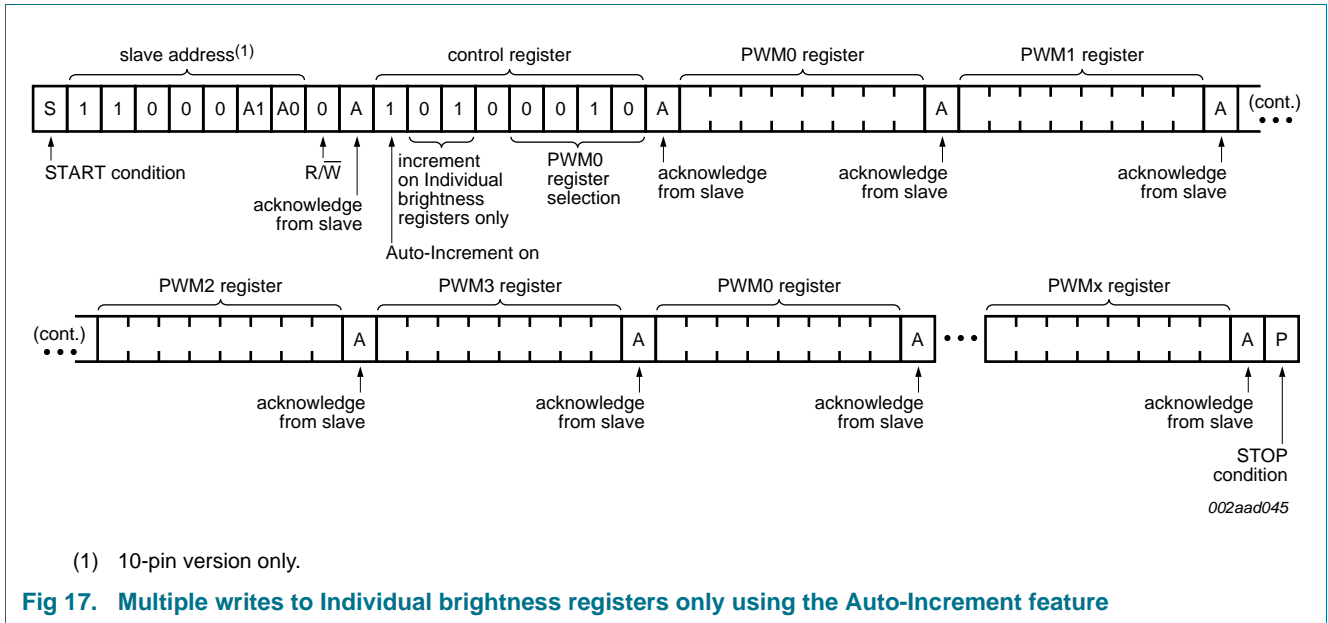
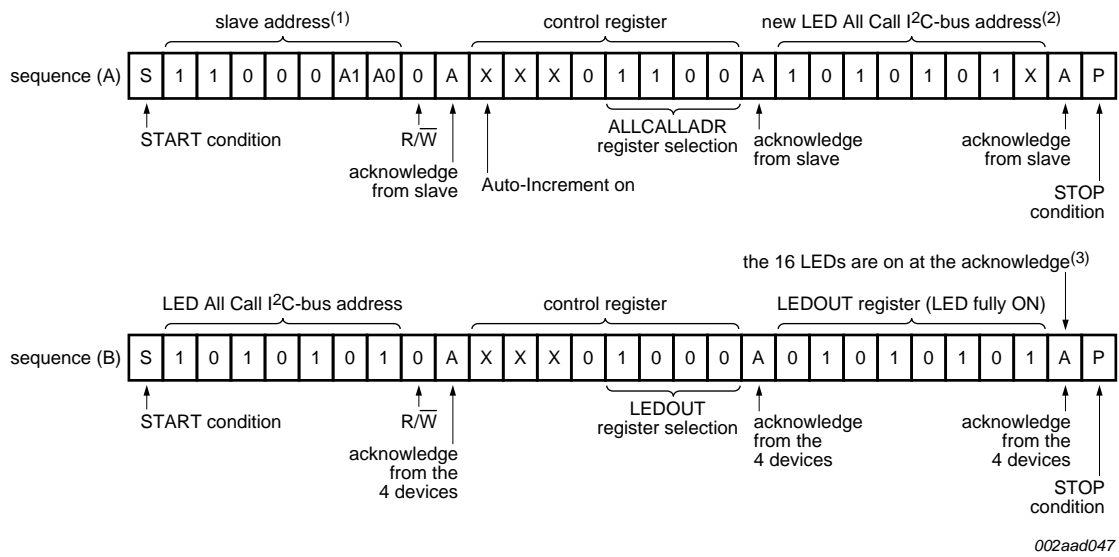

Fig 14. Acknowledgement on the I²C-bus

9. Bus transactions







- (1) 10-pin version is used for this figure. Four PCA9632DP2 or PCA9632TK2 and same sequence (A) (above) is sent to each of them. A[1:0] = 00 to 11.
- (2) ALLCALL bit in MODE1 register is equal to logic 1 for this example.
- (3) OCH bit in MODE2 register is equal to logic 1 for this example.

Fig 19. LED All Call I²C-bus address programming and LED All Call sequence example

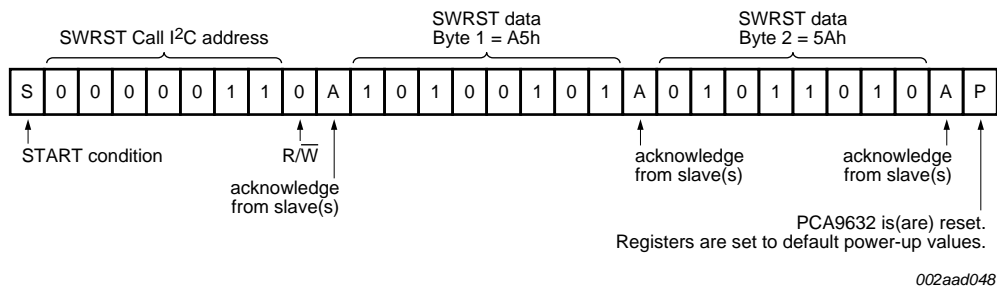
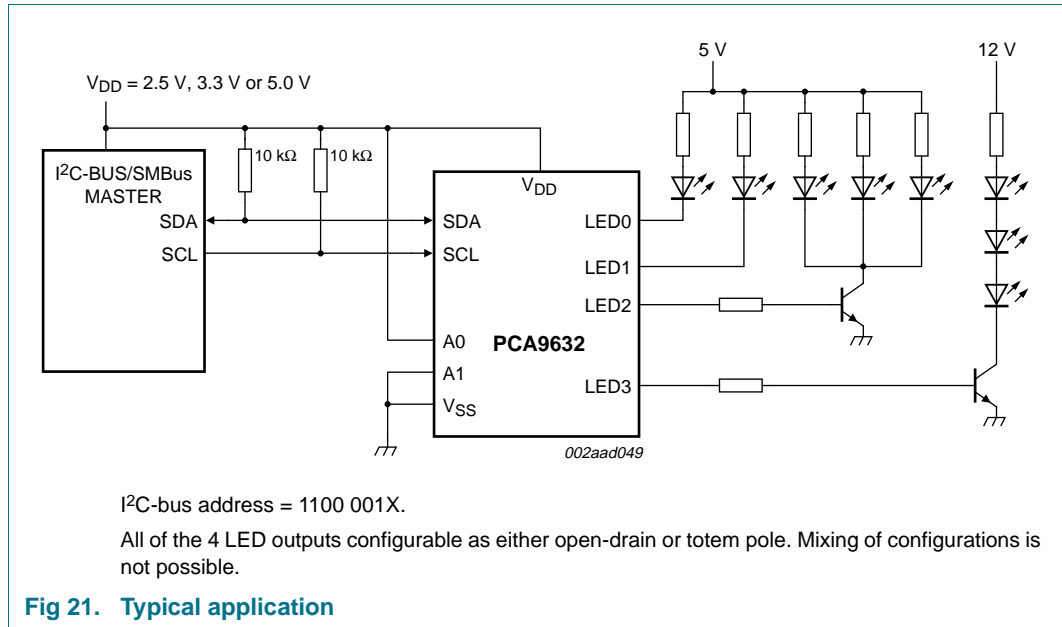

Fig 20. Software Reset (SWRST) Call sequence

10. Application design-in information



Question 1: What kind of edge rate control is there on the outputs?

- The typical edge rates depend on the output configuration, supply voltage, and the applied load. The outputs can be configured as either open-drain NMOS or totem pole outputs. If the customer is using the part to directly drive LEDs, they should be using it in an open-drain NMOS, if they are concerned about the maximum I_{SS} and ground bounce. The edge rate control was designed primarily to slow down the turn-on of the output device; it turns off rather quickly (~ 1.5 ns). In simulation, the typical turn-on time for the open-drain NMOS was ~ 14 ns (V_{DD} = 3.6 V; C_L = 50 pF; R_{PU} = 500 Ω).

Question 2: Is ground bounce possible?

- Ground bounce is a possibility, especially if all 16 outputs transition at full current (25 mA each). There is a fair amount of decoupling capacitance on chip (~ 50 pF), which is intended to suppress some of the ground bounce. The customer will need to determine if additional decoupling capacitance externally placed as close as physically possible to the device is required.

Question 3: Can I really sink 400 mA through the single ground pin on the package and will this cause any ground bounce problem due to the PWM of the LEDs?

- Yes, you can sink 400 mA through a single ground pin on the **package**. Although the package only has one ground pin, there are two ground pads on the die itself connected to this one pin. Although some ground bounce is likely, it will not disrupt the operation of the part and would be reduced by the external decoupling capacitance.

Question 4: I can't turn the LEDs on or off, but their registers are set properly. Why?

- Check the Mode register 1 bit 4 (MODE1[4]) SLEEP setting. The value needs to be a logic 0 so that the OSC is turned on. If the OSC is turned off, the LEDs cannot be turned on or off and also can't be dimmed or blinked.

Question 5: I'm using LEDs with integrated Zener diodes and the IC is getting very hot. Why?

- The IC outputs can be set to either open-drain or push-pull and default to push-pull outputs. In this application with the Zener diodes, they need to be set to open-drain since in the push-pull architecture there is a low resistance path to ground through the Zener and this is causing the IC to overheat. The PCA9632/33/34/35 ICs all power-up in the push-pull output mode and with the logic state HIGH, so one of the first things that need to be done is to set the outputs to open-drain.

11. Limiting values

Table 17. Limiting values

In accordance with the Absolute Maximum Rating System (IEC 60134).

| Symbol | Parameter | Conditions | Min | Max | Unit |
|----------------------|--------------------------------|------------|-----------------------|------|------|
| V _{DD} | supply voltage | | -0.5 | +6.0 | V |
| V _{I/O} | voltage on an input/output pin | | V _{SS} - 0.5 | 5.5 | V |
| I _{O(LEDn)} | output current on pin LEDn | | - | 25 | mA |
| I _{SS} | ground supply current | | - | 100 | mA |
| P _{tot} | total power dissipation | | - | 400 | mW |
| T _{stg} | storage temperature | | -65 | +150 | °C |
| T _{amb} | ambient temperature | operating | -40 | +85 | °C |

12. Static characteristics

Table 18. Static characteristics
 $V_{DD} = 2.3\text{ V to }5.5\text{ V}; V_{SS} = 0\text{ V}; T_{amb} = -40\text{ }^{\circ}\text{C to }+85\text{ }^{\circ}\text{C};$ unless otherwise specified.

| Symbol | Parameter | Conditions | Min | Typ | Max | Unit | |
|------------------------------------|--------------------------------|---|--------------|-------|---------------|---------------|----|
| Supply | | | | | | | |
| V_{DD} | supply voltage | | 2.3 | - | 5.5 | V | |
| I_{DD} | supply current | operating mode; no load; $f_{SCL} = 1\text{ MHz}$ | | | | | |
| | | $V_{DD} = 2.3\text{ V}$ | - | 38 | 150 | μA | |
| | | $V_{DD} = 3.3\text{ V}$ | - | 53 | 150 | μA | |
| | | $V_{DD} = 5.5\text{ V}$ | - | 108 | 150 | μA | |
| I_{stb} | standby current | no load; $f_{SCL} = 0\text{ Hz}; I/O = \text{inputs}; V_I = V_{DD}$ | | | | | |
| | | $V_{DD} = 5.5\text{ V}, \text{MODE1}[4] = 1$ (Sleep mode) | - | 0.005 | 1 | μA | |
| V_{POR} | power-on reset voltage | no load; $V_I = V_{DD}$ or V_{SS} | [1] | - | 1.70 | 2.0 | V |
| Input SCL; input/output SDA | | | | | | | |
| V_{IL} | LOW-level input voltage | | -0.5 | - | +0.3 V_{DD} | V | |
| V_{IH} | HIGH-level input voltage | | 0.7 V_{DD} | - | 5.5 | V | |
| I_{OL} | LOW-level output current | $V_{OL} = 0.4\text{ V}; V_{DD} = 2.3\text{ V}$ | 20 | - | - | mA | |
| | | $V_{OL} = 0.4\text{ V}; V_{DD} = 5.0\text{ V}$ | 30 | - | - | mA | |
| I_L | leakage current | $V_I = V_{DD}$ or V_{SS} | -1 | - | +1 | μA | |
| C_i | input capacitance | $V_I = V_{SS}$ | - | 6 | 10 | pF | |
| LED driver outputs | | | | | | | |
| I_{OL} | LOW-level output current | $V_{OL} = 0.5\text{ V}; V_{DD} = 2.3\text{ V}$ | [2] | 12 | - | - | mA |
| | | $V_{OL} = 0.5\text{ V}; V_{DD} = 3.0\text{ V}$ | [2] | 17 | - | - | mA |
| | | $V_{OL} = 0.5\text{ V}; V_{DD} = 4.5\text{ V}$ | [2] | 25 | - | - | mA |
| $I_{OL(tot)}$ | total LOW-level output current | $V_{OL} = 0.5\text{ V}; V_{DD} = 4.5\text{ V}$ | [2] | - | - | 100 | mA |
| V_{OH} | HIGH-level output voltage | $I_{OH} = -10\text{ mA}; V_{DD} = 2.3\text{ V}$ | 1.6 | - | - | V | |
| | | $I_{OH} = -10\text{ mA}; V_{DD} = 3.0\text{ V}$ | 2.3 | - | - | V | |
| | | $I_{OH} = -10\text{ mA}; V_{DD} = 4.5\text{ V}$ | 4.0 | - | - | V | |
| C_o | output capacitance | | - | 2.5 | 5 | pF | |

[1] V_{DD} must be lowered to 0.2 V in order to reset part.

[2] Each bit must be limited to a maximum of 25 mA and the total package limited to 100 mA due to internal busing limits.

13. Dynamic characteristics

Table 19. Dynamic characteristics

| Symbol | Parameter | Conditions | Standard- mode I ² C-bus | | Fast-mode I ² C-bus | | Fast-mode Plus I ² C-bus | | Unit |
|---------------------|---|------------|-------------------------------------|------|--------------------------------|-----|-------------------------------------|------|------|
| | | | Min | Max | Min | Max | Min | Max | |
| f _{SCL} | SCL clock frequency | [1] | 0 | 100 | 0 | 400 | 0 | 1000 | kHz |
| t _{BUF} | bus free time between a STOP and START condition | | 4.7 | - | 1.3 | - | 0.5 | - | μs |
| t _{HD;STA} | hold time (repeated) START condition | | 4.0 | - | 0.6 | - | 0.26 | - | μs |
| t _{SU;STA} | set-up time for a repeated START condition | | 4.7 | - | 0.6 | - | 0.26 | - | μs |
| t _{SU;STO} | set-up time for STOP condition | | 4.0 | - | 0.6 | - | 0.26 | - | μs |
| t _{HD;DAT} | data hold time | | 0 | - | 0 | - | 0 | - | ns |
| t _{VD;ACK} | data valid acknowledge time | [2] | 0.3 | 3.45 | 0.1 | 0.9 | 0.05 | 0.45 | μs |
| t _{VD;DAT} | data valid time | [3] | 0.3 | 3.45 | 0.1 | 0.9 | 0.05 | 0.45 | μs |
| t _{SU;DAT} | data set-up time | | 250 | - | 100 | - | 50 | - | ns |
| t _{LOW} | LOW period of the SCL clock | | 4.7 | - | 1.3 | - | 0.5 | - | μs |
| t _{HIGH} | HIGH period of the SCL clock | | 4.0 | - | 0.6 | - | 0.26 | - | μs |
| t _f | fall time of both SDA and SCL signals | [4][5] | - | 300 | 20 + 0.1C _b [6] | 300 | - | 120 | ns |
| t _r | rise time of both SDA and SCL signals | | - | 1000 | 20 + 0.1C _b [6] | 300 | - | 120 | ns |
| t _{SP} | pulse width of spikes that must be suppressed by the input filter | [7] | - | 50 | - | 50 | - | 50 | ns |

- [1] Minimum SCL clock frequency is limited by the bus time-out feature, which resets the serial bus interface if either SDA or SCL is held LOW for a minimum of 25 ms. Disable bus time-out feature for DC operation.
- [2] t_{VD;ACK} = time for Acknowledgement signal from SCL LOW to SDA (out) LOW.
- [3] t_{VD;DAT} = minimum time for SDA data out to be valid following SCL LOW.
- [4] A master device must internally provide a hold time of at least 300 ns for the SDA signal (refer to [Table 18](#), V_{IL} of the SCL signal) in order to bridge the undefined region of SCL's falling edge.
- [5] The maximum t_f for the SDA and SCL bus lines is specified at 300 ns. The maximum fall time (t_f) for the SDA output stage is specified at 250 ns. This allows series protection resistors to be connected between the SDA and the SCL pins and the SDA/SCL bus lines without exceeding the maximum specified t_f.
- [6] C_b = total capacitance of one bus line in pF.
- [7] Input filters on the SDA and SCL inputs suppress noise spikes less than 50 ns.

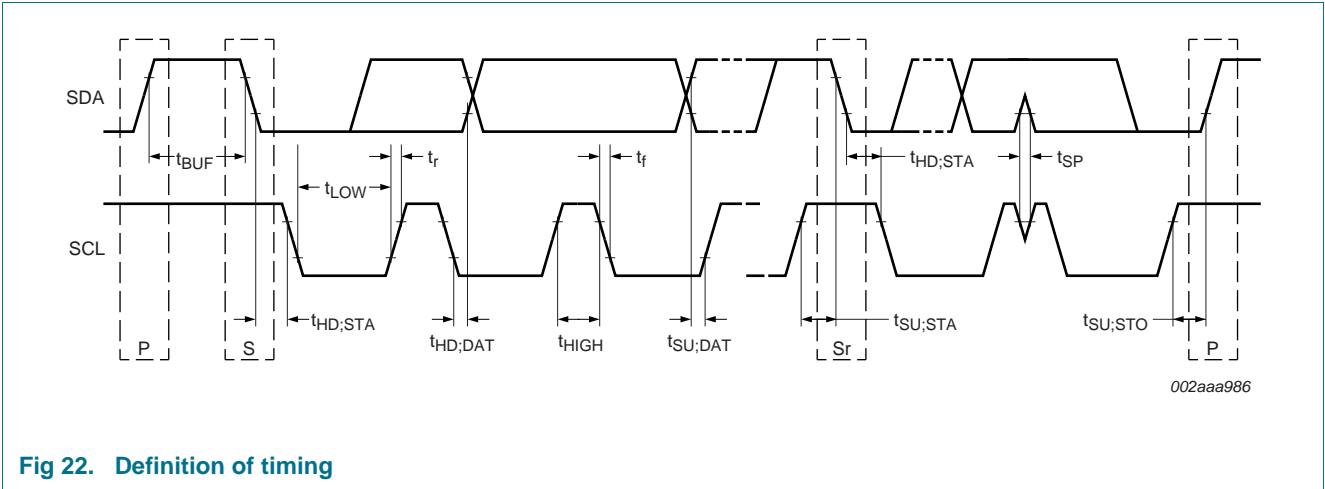

Fig 22. Definition of timing

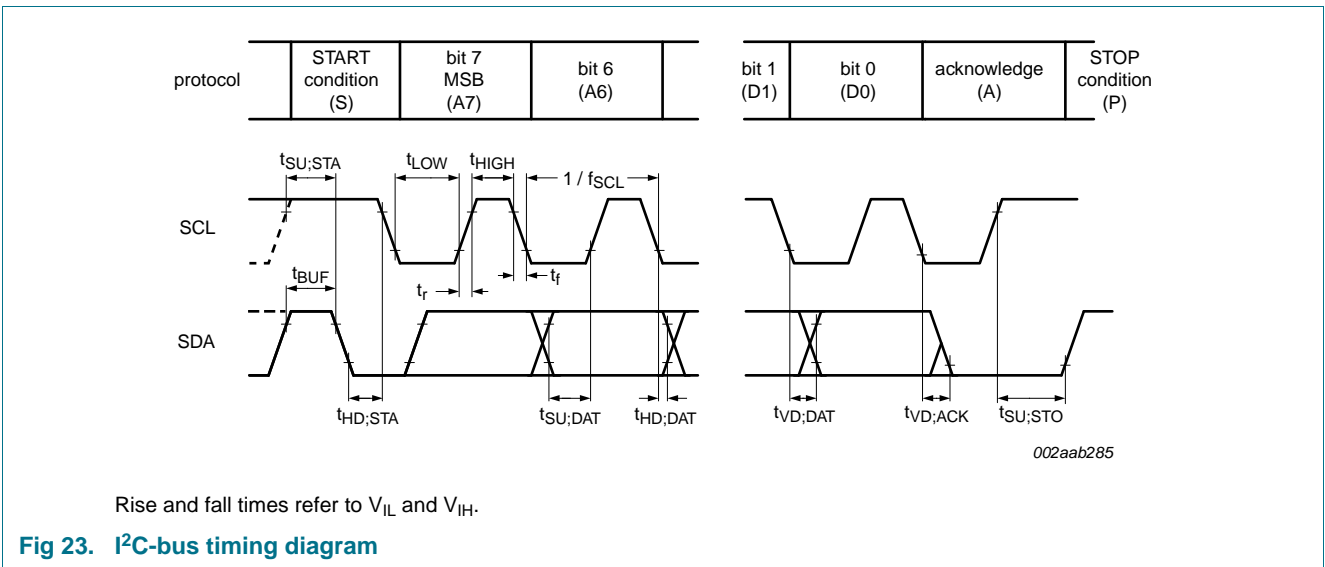

Fig 23. I²C-bus timing diagram

14. Test information

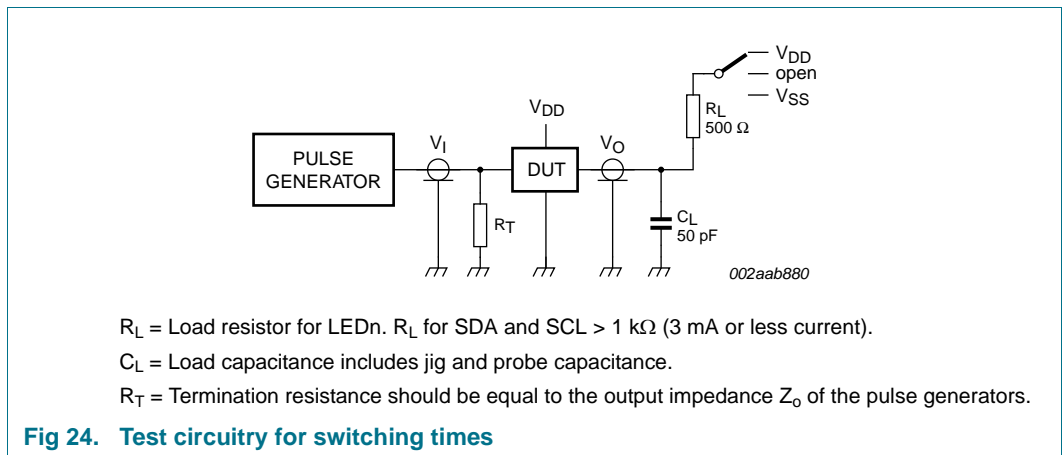

Fig 24. Test circuitry for switching times

15. Package outline

TSSOP8: plastic thin shrink small outline package; 8 leads; body width 3 mm

SOT505-1

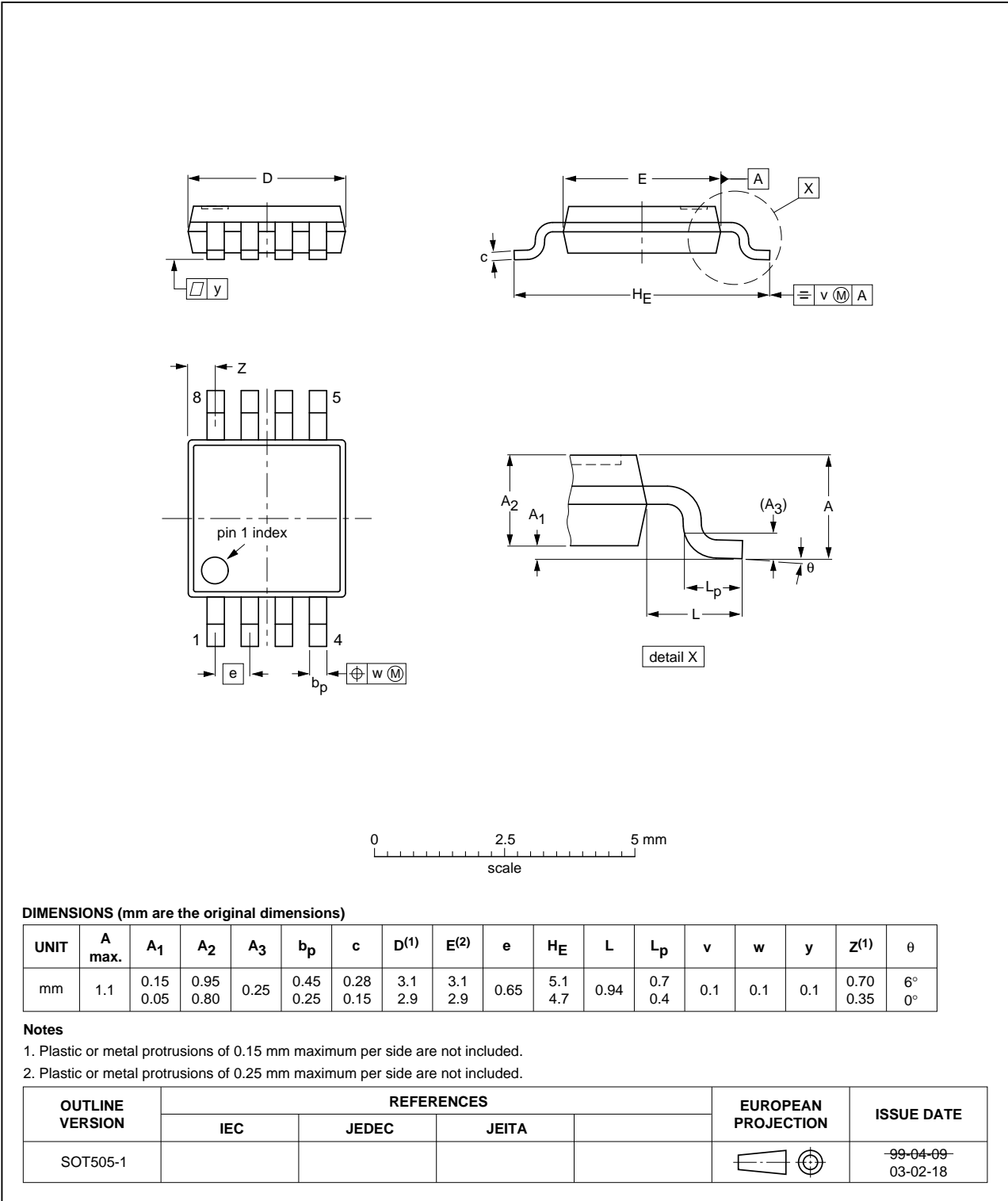

Fig 25. Package outline SOT505-1 (TSSOP8)

HVSON8: plastic thermal enhanced very thin small outline package; no leads;
8 terminals; body 3 x 3 x 0.85 mm

SOT908-1

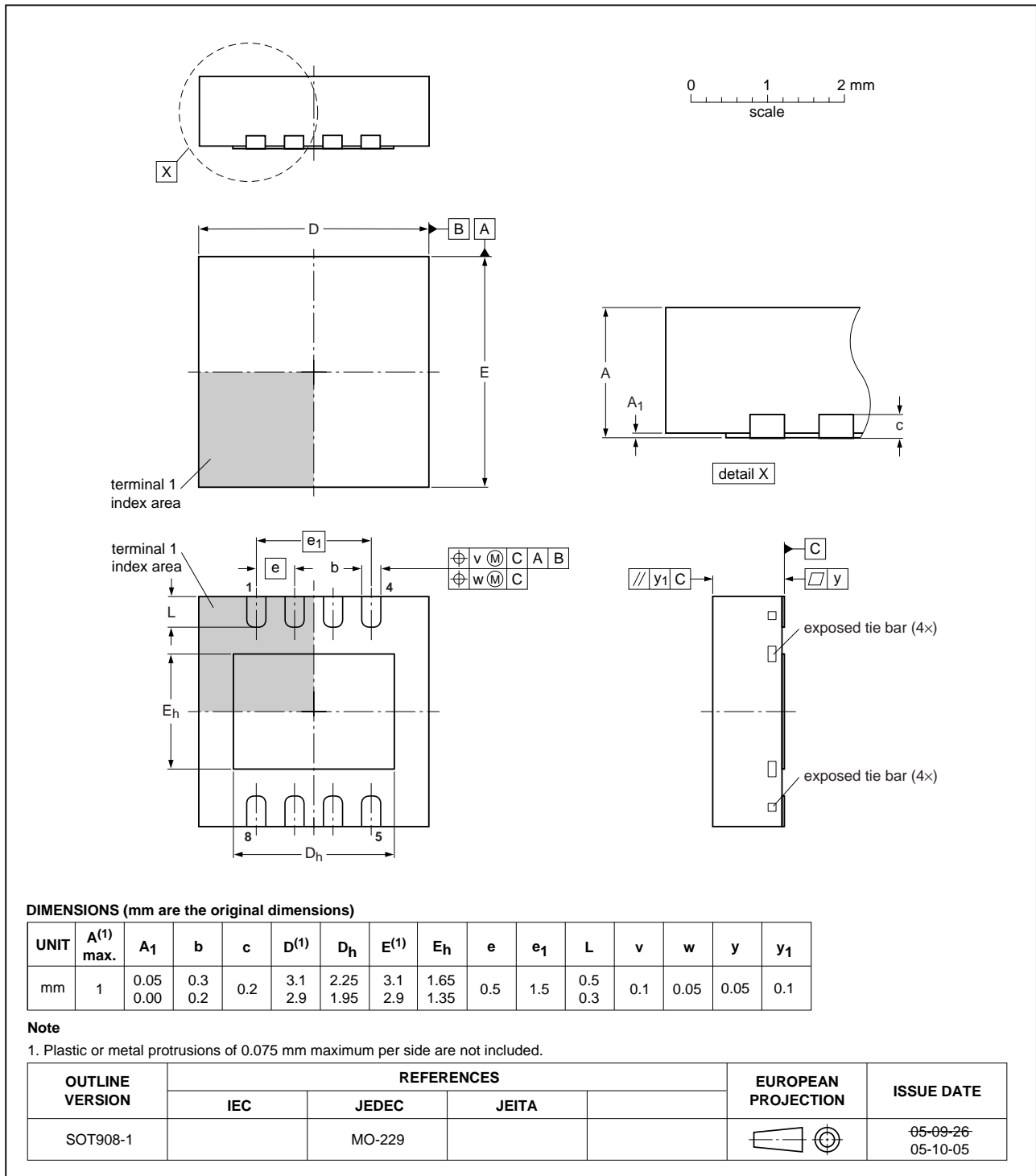

Fig 26. Package outline SOT908-1 (HVSON8)

TSSOP10: plastic thin shrink small outline package; 10 leads; body width 3 mm

SOT552-1

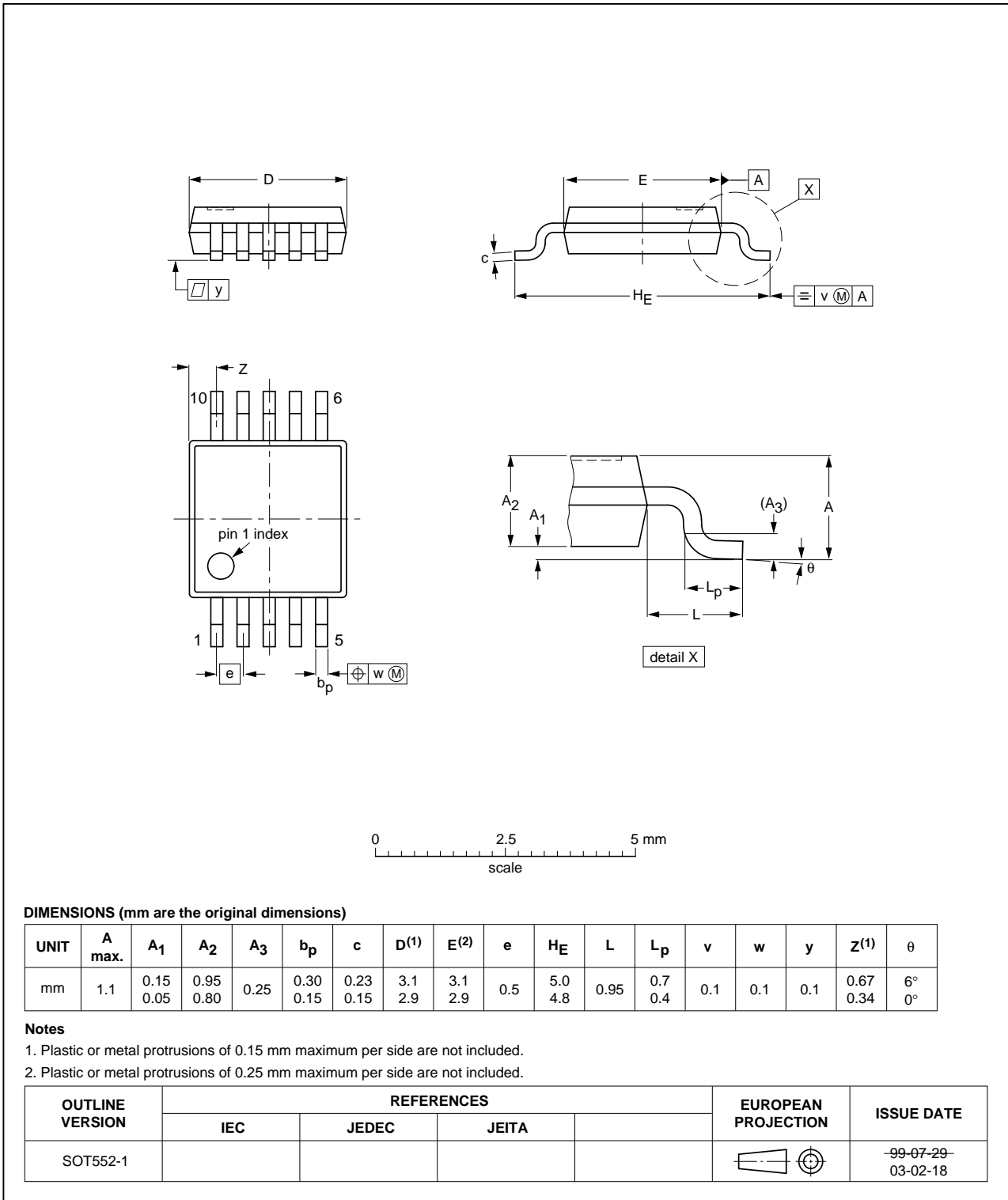

Fig 27. Package outline SOT552-1 (TSSOP10)

**HVSON10: plastic thermal enhanced very thin small outline package; no leads;
10 terminals; body 3 x 3 x 0.85 mm**

SOT650-1

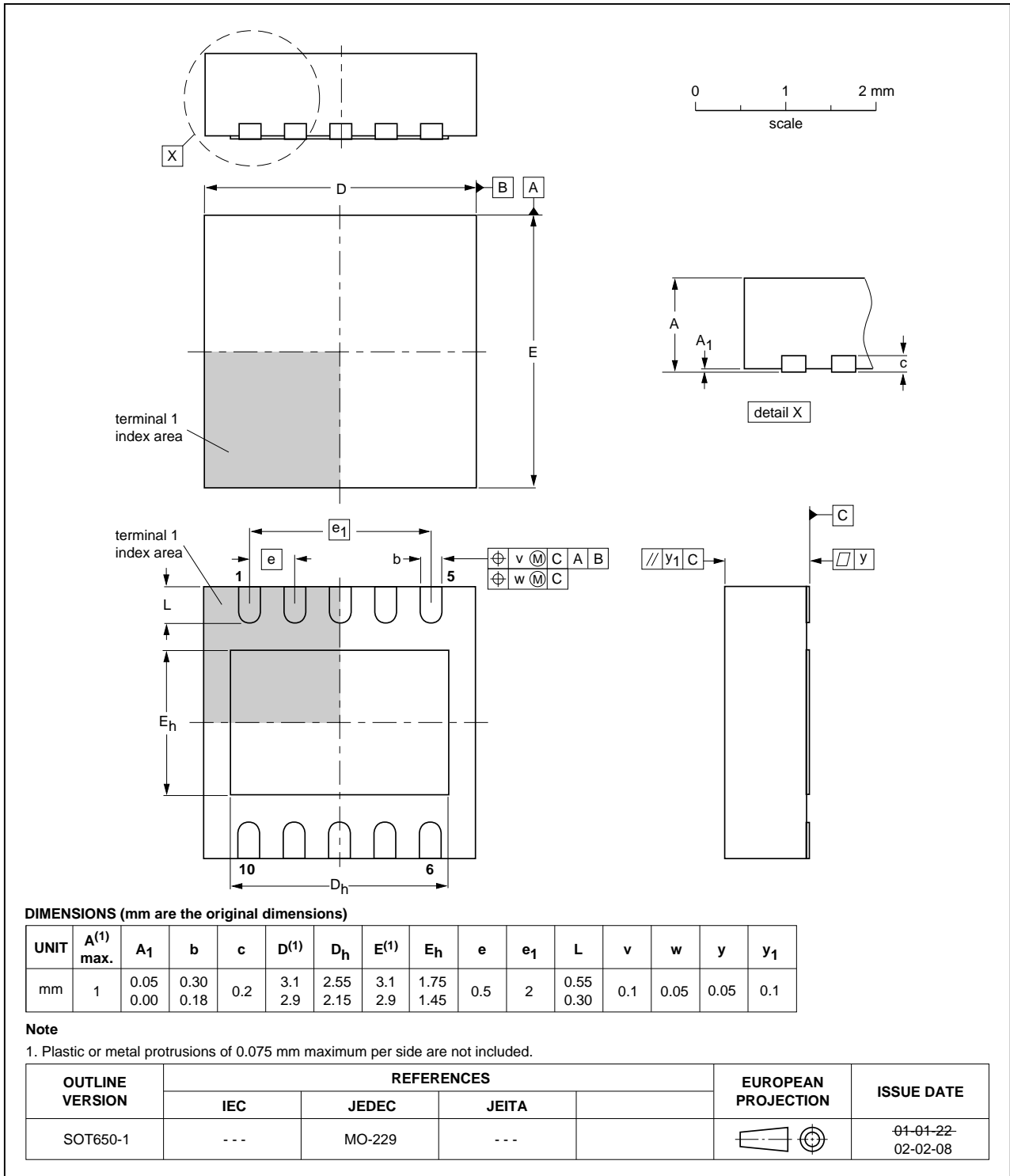

Fig 28. Package outline SOT650-1 (HVSON10)

16. Handling information

All input and output pins are protected against ElectroStatic Discharge (ESD) under normal handling. When handling ensure that the appropriate precautions are taken as described in *JESD625-A* or equivalent standards.

17. Soldering of SMD packages

This text provides a very brief insight into a complex technology. A more in-depth account of soldering ICs can be found in Application Note *AN10365 "Surface mount reflow soldering description"*.

17.1 Introduction to soldering

Soldering is one of the most common methods through which packages are attached to Printed Circuit Boards (PCBs), to form electrical circuits. The soldered joint provides both the mechanical and the electrical connection. There is no single soldering method that is ideal for all IC packages. Wave soldering is often preferred when through-hole and Surface Mount Devices (SMDs) are mixed on one printed wiring board; however, it is not suitable for fine pitch SMDs. Reflow soldering is ideal for the small pitches and high densities that come with increased miniaturization.

17.2 Wave and reflow soldering

Wave soldering is a joining technology in which the joints are made by solder coming from a standing wave of liquid solder. The wave soldering process is suitable for the following:

- Through-hole components
- Leaded or leadless SMDs, which are glued to the surface of the printed circuit board

Not all SMDs can be wave soldered. Packages with solder balls, and some leadless packages which have solder lands underneath the body, cannot be wave soldered. Also, leaded SMDs with leads having a pitch smaller than ~0.6 mm cannot be wave soldered, due to an increased probability of bridging.

The reflow soldering process involves applying solder paste to a board, followed by component placement and exposure to a temperature profile. Leaded packages, packages with solder balls, and leadless packages are all reflow solderable.

Key characteristics in both wave and reflow soldering are:

- Board specifications, including the board finish, solder masks and vias
- Package footprints, including solder thieves and orientation
- The moisture sensitivity level of the packages
- Package placement
- Inspection and repair
- Lead-free soldering versus SnPb soldering

17.3 Wave soldering

Key characteristics in wave soldering are:

- Process issues, such as application of adhesive and flux, clinching of leads, board transport, the solder wave parameters, and the time during which components are exposed to the wave
- Solder bath specifications, including temperature and impurities

17.4 Reflow soldering

Key characteristics in reflow soldering are:

- Lead-free versus SnPb soldering; note that a lead-free reflow process usually leads to higher minimum peak temperatures (see [Figure 29](#)) than a SnPb process, thus reducing the process window
- Solder paste printing issues including smearing, release, and adjusting the process window for a mix of large and small components on one board
- Reflow temperature profile; this profile includes preheat, reflow (in which the board is heated to the peak temperature) and cooling down. It is imperative that the peak temperature is high enough for the solder to make reliable solder joints (a solder paste characteristic). In addition, the peak temperature must be low enough that the packages and/or boards are not damaged. The peak temperature of the package depends on package thickness and volume and is classified in accordance with [Table 20](#) and [21](#)

Table 20. SnPb eutectic process (from J-STD-020C)

| Package thickness (mm) | Package reflow temperature (°C) | |
|------------------------|---------------------------------|-------|
| | Volume (mm ³) | |
| | < 350 | ≥ 350 |
| < 2.5 | 235 | 220 |
| ≥ 2.5 | 220 | 220 |

Table 21. Lead-free process (from J-STD-020C)

| Package thickness (mm) | Package reflow temperature (°C) | | |
|------------------------|---------------------------------|-------------|--------|
| | Volume (mm ³) | | |
| | < 350 | 350 to 2000 | > 2000 |
| < 1.6 | 260 | 260 | 260 |
| 1.6 to 2.5 | 260 | 250 | 245 |
| > 2.5 | 250 | 245 | 245 |

Moisture sensitivity precautions, as indicated on the packing, must be respected at all times.

Studies have shown that small packages reach higher temperatures during reflow soldering, see [Figure 29](#).

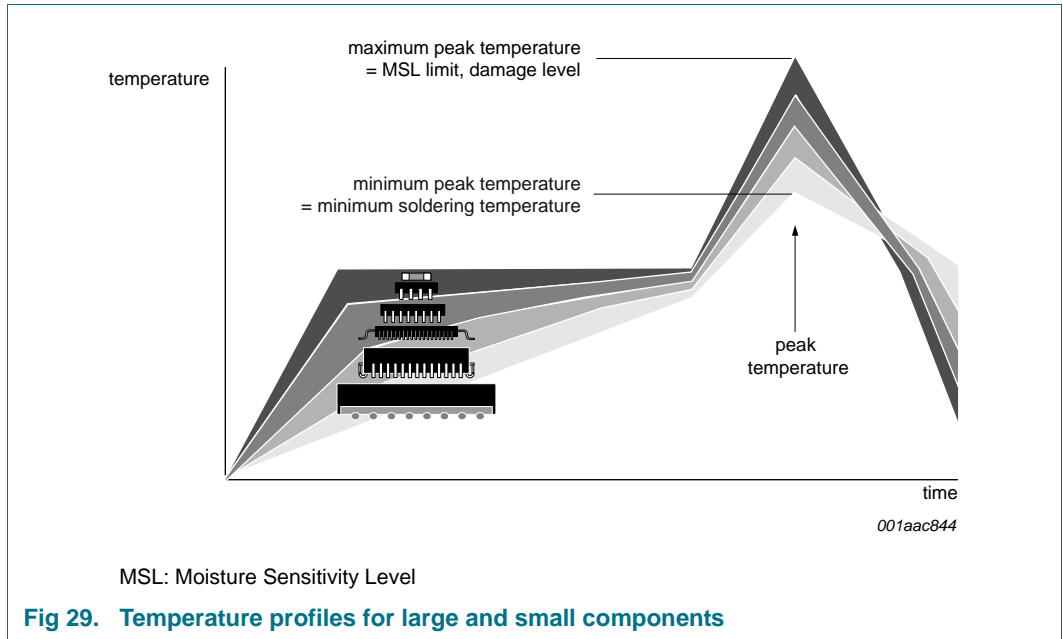

For further information on temperature profiles, refer to Application Note AN10365 “Surface mount reflow soldering description”.

18. Abbreviations

Table 22. Abbreviations

| Acronym | Description |
|----------------------|--|
| CDM | Charged-Device Model |
| DUT | Device Under Test |
| ESD | ElectroStatic Discharge |
| HBM | Human Body Model |
| I ² C-bus | Inter-Integrated Circuit bus |
| LCD | Liquid Crystal Display |
| LED | Light Emitting Diode |
| LSB | Least Significant Bit |
| MSB | Most Significant Bit |
| NMOS | Negative-channel Metal-Oxide Semiconductor |
| PCB | Printed-Circuit Board |
| PMOS | Positive-channel Metal-Oxide Semiconductor |
| PWM | Pulse Width Modulation |
| RGB | Red/Green/Blue |
| RGBA | Red/Green/Blue/Amber |
| SMBus | System Management Bus |

19. Revision history

Table 23. Revision history

| Document ID | Release date | Data sheet status | Change notice | Supersedes |
|----------------|--|----------------------|---------------|-------------|
| PCA9632 v.5 | 20110727 | Product data sheet | - | PCA9632 v.4 |
| Modifications: | <ul style="list-style-type: none"> • Figure 10 "Brightness + group dimming signals" modified | | | |
| PCA9632 v.4 | 20110701 | Product data sheet | - | PCA9632 v.3 |
| Modifications: | <ul style="list-style-type: none"> • Section 2 "Features and benefits", 24th bullet item: deleted phrase "200 V MM per JESD22-A115" • Table 18 "Static characteristics", sub-section "Supply": <ul style="list-style-type: none"> – Condition for I_{DD}: changed from "f_{SCL} = 0 MHz" to "f_{SCL} = 1 MHz" – Condition for I_{stb}: appended ", MODE1[4] = 1 (Sleep mode)" | | | |
| PCA9632 v.3 | 20080715 | Product data sheet | - | PCA9632 v.2 |
| PCA9632 v.2 | 20080401 | Product data sheet | - | PCA9632 v.1 |
| PCA9632 v.1 | 20070928 | Objective data sheet | - | - |

20. Legal information

20.1 Data sheet status

| Document status ^{[1][2]} | Product status ^[3] | Definition |
|-----------------------------------|-------------------------------|---|
| Objective [short] data sheet | Development | This document contains data from the objective specification for product development. |
| Preliminary [short] data sheet | Qualification | This document contains data from the preliminary specification. |
| Product [short] data sheet | Production | This document contains the product specification. |

[1] Please consult the most recently issued document before initiating or completing a design.

[2] The term 'short data sheet' is explained in section "Definitions".

[3] The product status of device(s) described in this document may have changed since this document was published and may differ in case of multiple devices. The latest product status information is available on the Internet at URL <http://www.nxp.com>.

20.2 Definitions

Draft — The document is a draft version only. The content is still under internal review and subject to formal approval, which may result in modifications or additions. NXP Semiconductors does not give any representations or warranties as to the accuracy or completeness of information included herein and shall have no liability for the consequences of use of such information.

Short data sheet — A short data sheet is an extract from a full data sheet with the same product type number(s) and title. A short data sheet is intended for quick reference only and should not be relied upon to contain detailed and full information. For detailed and full information see the relevant full data sheet, which is available on request via the local NXP Semiconductors sales office. In case of any inconsistency or conflict with the short data sheet, the full data sheet shall prevail.

Product specification — The information and data provided in a Product data sheet shall define the specification of the product as agreed between NXP Semiconductors and its customer, unless NXP Semiconductors and customer have explicitly agreed otherwise in writing. In no event however, shall an agreement be valid in which the NXP Semiconductors product is deemed to offer functions and qualities beyond those described in the Product data sheet.

20.3 Disclaimers

Limited warranty and liability — Information in this document is believed to be accurate and reliable. However, NXP Semiconductors does not give any representations or warranties, expressed or implied, as to the accuracy or completeness of such information and shall have no liability for the consequences of use of such information.

In no event shall NXP Semiconductors be liable for any indirect, incidental, punitive, special or consequential damages (including - without limitation - lost profits, lost savings, business interruption, costs related to the removal or replacement of any products or rework charges) whether or not such damages are based on tort (including negligence), warranty, breach of contract or any other legal theory.

Notwithstanding any damages that customer might incur for any reason whatsoever, NXP Semiconductors' aggregate and cumulative liability towards customer for the products described herein shall be limited in accordance with the *Terms and conditions of commercial sale* of NXP Semiconductors.

Right to make changes — NXP Semiconductors reserves the right to make changes to information published in this document, including without limitation specifications and product descriptions, at any time and without notice. This document supersedes and replaces all information supplied prior to the publication hereof.

Suitability for use — NXP Semiconductors products are not designed, authorized or warranted to be suitable for use in life support, life-critical or safety-critical systems or equipment, nor in applications where failure or

malfunction of an NXP Semiconductors product can reasonably be expected to result in personal injury, death or severe property or environmental damage. NXP Semiconductors accepts no liability for inclusion and/or use of NXP Semiconductors products in such equipment or applications and therefore such inclusion and/or use is at the customer's own risk.

Applications — Applications that are described herein for any of these products are for illustrative purposes only. NXP Semiconductors makes no representation or warranty that such applications will be suitable for the specified use without further testing or modification.

Customers are responsible for the design and operation of their applications and products using NXP Semiconductors products, and NXP Semiconductors accepts no liability for any assistance with applications or customer product design. It is customer's sole responsibility to determine whether the NXP Semiconductors product is suitable and fit for the customer's applications and products planned, as well as for the planned application and use of customer's third party customer(s). Customers should provide appropriate design and operating safeguards to minimize the risks associated with their applications and products.

NXP Semiconductors does not accept any liability related to any default, damage, costs or problem which is based on any weakness or default in the customer's applications or products, or the application or use by customer's third party customer(s). Customer is responsible for doing all necessary testing for the customer's applications and products using NXP Semiconductors products in order to avoid a default of the applications and the products or of the application or use by customer's third party customer(s). NXP does not accept any liability in this respect.

Limiting values — Stress above one or more limiting values (as defined in the Absolute Maximum Ratings System of IEC 60134) will cause permanent damage to the device. Limiting values are stress ratings only and (proper) operation of the device at these or any other conditions above those given in the Recommended operating conditions section (if present) or the Characteristics sections of this document is not warranted. Constant or repeated exposure to limiting values will permanently and irreversibly affect the quality and reliability of the device.

Terms and conditions of commercial sale — NXP Semiconductors products are sold subject to the general terms and conditions of commercial sale, as published at <http://www.nxp.com/profile/terms>, unless otherwise agreed in a valid written individual agreement. In case an individual agreement is concluded only the terms and conditions of the respective agreement shall apply. NXP Semiconductors hereby expressly objects to applying the customer's general terms and conditions with regard to the purchase of NXP Semiconductors products by customer.

No offer to sell or license — Nothing in this document may be interpreted or construed as an offer to sell products that is open for acceptance or the grant, conveyance or implication of any license under any copyrights, patents or other industrial or intellectual property rights.

Export control — This document as well as the item(s) described herein may be subject to export control regulations. Export might require a prior authorization from national authorities.

Non-automotive qualified products — Unless this data sheet expressly states that this specific NXP Semiconductors product is automotive qualified, the product is not suitable for automotive use. It is neither qualified nor tested in accordance with automotive testing or application requirements. NXP Semiconductors accepts no liability for inclusion and/or use of non-automotive qualified products in automotive equipment or applications.

In the event that customer uses the product for design-in and use in automotive applications to automotive specifications and standards, customer (a) shall use the product without NXP Semiconductors' warranty of the product for such automotive applications, use and specifications, and (b) whenever customer uses the product for automotive applications beyond NXP Semiconductors' specifications such use shall be solely at customer's

own risk, and (c) customer fully indemnifies NXP Semiconductors for any liability, damages or failed product claims resulting from customer design and use of the product for automotive applications beyond NXP Semiconductors' standard warranty and NXP Semiconductors' product specifications.

20.4 Trademarks

Notice: All referenced brands, product names, service names and trademarks are the property of their respective owners.

I²C-bus — logo is a trademark of NXP B.V.

21. Contact information

For more information, please visit: <http://www.nxp.com>

For sales office addresses, please send an email to: salesaddresses@nxp.com

22. Contents

| | | | | | |
|-----------|---|-----------|-----------|--------------------------------------|-----------|
| 1 | General description | 1 | 17.1 | Introduction to soldering. | 33 |
| 2 | Features and benefits | 2 | 17.2 | Wave and reflow soldering. | 33 |
| 3 | Applications | 3 | 17.3 | Wave soldering | 33 |
| 4 | Ordering information | 3 | 17.4 | Reflow soldering | 34 |
| 5 | Block diagram | 4 | 18 | Abbreviations | 35 |
| 6 | Pinning information | 5 | 19 | Revision history | 36 |
| 6.1 | Pinning | 5 | 20 | Legal information | 37 |
| 6.2 | Pin description | 5 | 20.1 | Data sheet status | 37 |
| 7 | Functional description | 6 | 20.2 | Definitions | 37 |
| 7.1 | Device addresses | 6 | 20.3 | Disclaimers | 37 |
| 7.1.1 | Regular I ² C-bus slave address. | 6 | 20.4 | Trademarks | 38 |
| 7.1.2 | LED All Call I ² C-bus address | 7 | 21 | Contact information | 38 |
| 7.1.3 | LED Sub Call I ² C-bus addresses | 7 | 22 | Contents | 39 |
| 7.1.4 | Software reset I ² C-bus address | 8 | | | |
| 7.2 | Control register | 8 | | | |
| 7.3 | Register definitions | 10 | | | |
| 7.3.1 | Mode register 1, MODE1 | 11 | | | |
| 7.3.2 | Mode register 2, MODE2 | 11 | | | |
| 7.3.3 | PWM registers 0 to 3, PWMx — Individual brightness control registers | 12 | | | |
| 7.3.4 | Group duty cycle control, GRPPWM | 13 | | | |
| 7.3.5 | Group frequency, GRPFREQ | 14 | | | |
| 7.3.6 | LED driver output state, LEDOUT | 14 | | | |
| 7.3.7 | I ² C-bus subaddress 1 to 3, SUBADRx | 14 | | | |
| 7.3.8 | LED All Call I ² C-bus address, ALLCALLADR. | 15 | | | |
| 7.4 | Power-on reset | 15 | | | |
| 7.5 | Software reset | 15 | | | |
| 7.6 | Using the PCA9632 with and without external drivers. | 16 | | | |
| 7.7 | Individual brightness control with group dimming/blinking. | 17 | | | |
| 8 | Characteristics of the I²C-bus | 19 | | | |
| 8.1 | Bit transfer | 19 | | | |
| 8.1.1 | START and STOP conditions | 19 | | | |
| 8.2 | System configuration | 19 | | | |
| 8.3 | Acknowledge | 20 | | | |
| 9 | Bus transactions | 21 | | | |
| 10 | Application design-in information | 24 | | | |
| 11 | Limiting values | 25 | | | |
| 12 | Static characteristics | 26 | | | |
| 13 | Dynamic characteristics | 27 | | | |
| 14 | Test information | 28 | | | |
| 15 | Package outline | 29 | | | |
| 16 | Handling information | 33 | | | |
| 17 | Soldering of SMD packages | 33 | | | |

Please be aware that important notices concerning this document and the product(s) described herein, have been included in section 'Legal information'.

© NXP B.V. 2011.

All rights reserved.

For more information, please visit: <http://www.nxp.com>



For sales office addresses, please send an email to: salesaddresses@nxp.com

Date of release: 27 July 2011

Document identifier: PCA9632

Looking for pricing, stock, or lifecycle information?

Click below to explore more details on WIN SOURCE:

-  [View PCA9632TK,118 on WIN SOURCE](#)
-  [NXP / Nexperia Information](#)

Optimize Your Supply Chain with WIN SOURCE Solutions

-  Global Sourcing Solution
-  Obsolete Management
-  Cost Control Management
-  Shortage Management
-  Alternative Solution
-  Excess Inventory Management