



# THE DATASHEET OF PCA9555RGER



# PCA9555 Remote 16-bit I<sup>2</sup>C and SMBus I/O Expander with Interrupt Output and Configuration Registers

## 1 Features

- Low Standby-Current Consumption of 1  $\mu$ A Max
- I<sup>2</sup>C to Parallel Port Expander
- Open-Drain Active-Low Interrupt Output
- 5-V Tolerant I/O Ports
- Compatible With Most Microcontrollers
- 400-kHz Fast I<sup>2</sup>C Bus
- Address by Three Hardware Address Pins for Use of up to Eight Devices
- Polarity Inversion Register
- Latched Outputs With High-Current Drive Capability for Directly Driving LEDs
- Latch-Up Performance Exceeds 100 mA Per JESD 78, Class II
- ESD Protection Exceeds JESD 22
  - 2000-V Human-Body Model (A114-A)
  - 200-V Machine Model (A115-A)
  - 1000-V Charged-Device Model (C101)

## 2 Applications

- Servers
- Routers (Telecom Switching Equipment)
- Personal Computers
- Personal Electronics
- Industrial Automation Equipment
- Products with GPIO-Limited Processors

## 3 Description

This 16-bit I/O expander for the two-line bidirectional bus (I<sup>2</sup>C) is designed for 2.3-V to 5.5-V  $V_{CC}$  operation. It provides general-purpose remote I/O expansion for most microcontroller families via the I<sup>2</sup>C interface [serial clock (SCL), serial data (SDA)].

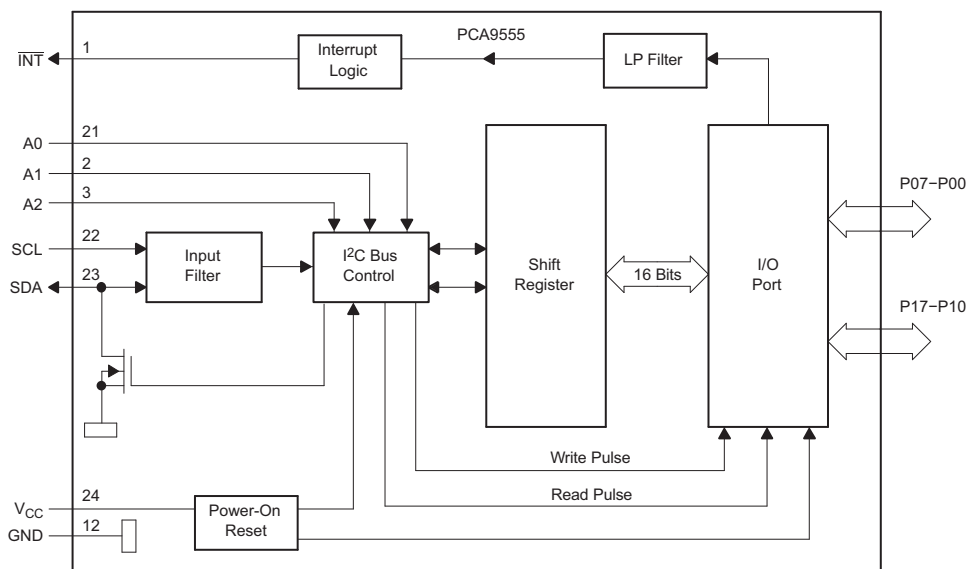
The PCA9555 consists of two 8-bit Configuration (input or output selection), Input Port, Output Port, and Polarity Inversion (active high or active low operation) registers. At power on, the I/Os are configured as inputs. The system master can enable the I/Os as either inputs or outputs by writing to the I/O configuration bits. The data for each input or output is kept in the corresponding Input or Output register. The polarity of the Input Port register can be inverted with the Polarity Inversion register. All registers can be read by the system master.

### Device Information<sup>(1)</sup>

PART NUMBER	PACKAGE	BODY SIZE (NOM)
PCA9555	SSOP (24) DB	8.20 mm x 5.30 mm
	SSOP (24) DBQ	8.65 mm x 3.90 mm
	TVSOP (24) DGV	5.00 mm x 4.40 mm
	SOIC (24) DW	15.4 mm x 7.50 mm
	SSOP (24) PW	7.80 mm x 4.40 mm
	VQFN (24) RGE	4.00 mm x 4.00 mm

(1) For all available packages, see the orderable addendum at the end of the datasheet.

### Block Diagram



## Table of Contents

<b>1 Features</b> .....	<b>1</b>	8.3 Device Features .....	<b>14</b>
<b>2 Applications</b> .....	<b>1</b>	8.4 Device Functional Modes.....	<b>15</b>
<b>3 Description</b> .....	<b>1</b>	8.5 Programming.....	<b>16</b>
<b>4 Revision History</b> .....	<b>2</b>	<b>9 Application and Implementation</b> .....	<b>23</b>
<b>5 Pin Configuration and Functions</b> .....	<b>3</b>	9.1 Application Information.....	<b>23</b>
<b>6 Specifications</b> .....	<b>4</b>	9.2 Typical Application .....	<b>23</b>
6.1 Absolute Maximum Ratings .....	<b>4</b>	<b>10 Power Supply Recommendations</b> .....	<b>25</b>
6.2 ESD Ratings.....	<b>4</b>	10.1 Power-On Reset Errata.....	<b>25</b>
6.3 Recommended Operating Conditions.....	<b>4</b>	<b>11 Layout</b> .....	<b>26</b>
6.4 Thermal Information .....	<b>5</b>	11.1 Layout Guidelines .....	<b>26</b>
6.5 Thermal Information .....	<b>5</b>	11.2 Layout Example .....	<b>26</b>
6.6 Electrical Characteristics.....	<b>6</b>	<b>12 Device and Documentation Support</b> .....	<b>27</b>
6.7 I <sup>2</sup> C Interface Timing Requirements.....	<b>6</b>	12.1 Receiving Notification of Documentation Updates	<b>27</b>
6.8 Switching Characteristics.....	<b>7</b>	12.2 Community Resources.....	<b>27</b>
6.9 Typical Characteristics.....	<b>8</b>	12.3 Trademarks .....	<b>27</b>
<b>7 Parameter Measurement Information</b> .....	<b>11</b>	12.4 Electrostatic Discharge Caution.....	<b>27</b>
<b>8 Detailed Description</b> .....	<b>13</b>	12.5 Glossary .....	<b>27</b>
8.1 Overview .....	<b>13</b>	<b>13 Mechanical, Packaging, and Orderable</b>	<b>27</b>
8.2 Functional Block Diagram .....	<b>13</b>	<b>Information</b> .....	<b>27</b>

## 4 Revision History

### Changes from Revision H (April 2019) to Revision I Page

- Changed the *I<sup>2</sup>C Interface Timing Requirements* table .....

**6**

### Changes from Revision G (March 2018) to Revision H Page

- Changed the *Device Information* table .....
- Added the DW package to the *Thermal Information* table .....

**1**

**5**

### Changes from Revision F (June 2014) to Revision G Page

- Added the *Applications* list .....
- Removed the Thermal Information from the *Absolute Maximum Ratings*.....
- Added Storage temperature range to the *Absolute Maximum Ratings*.....
- Changed the Handling Ratings table to the *ESD Ratings* table .....
- Added the *Thermal Information* table .....
- Changed From: "V<sub>CC</sub> must be lowered to below 0.2 V" To: V<sub>CC</sub> must be lowered to 0 V" in the *Power-On Reset* section.
- Added the *Design Requirements* section .....
- Added the *Application Curves* section .....
- Added the *Layout* section .....

**1**

**4**

**4**

**4**

**5**

**14**

**24**

**25**

**26**

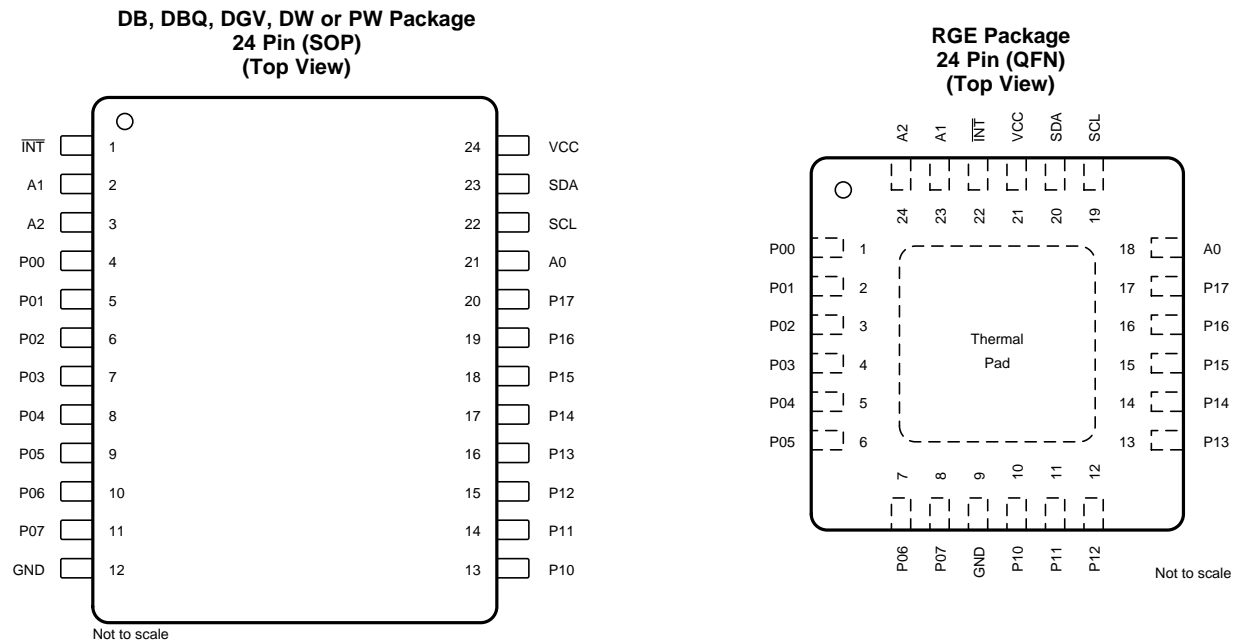
### Changes from Revision E (May 2008) to Revision F Page

- Added Interrupt Errata section.....
- Added Power-On Reset Errata section. ....

**15**

**25**

## 5 Pin Configuration and Functions



### Pin Functions

NAME	PIN		DESCRIPTION
	SSOP (DB), QSOP (DBQ), TSSOP (PW), AND TVSOP (DGV)	QFN (RGE)	
$\overline{\text{INT}}$	1	22	Interrupt output. Connect to $V_{CC}$ through a pullup resistor.
A1	2	23	Address input 1. Connect directly to $V_{CC}$ or ground.
A2	3	24	Address input 2. Connect directly to $V_{CC}$ or ground.
P00	4	1	P-port input/output. Push-pull design structure.
P01	5	2	P-port input/output. Push-pull design structure.
P02	6	3	P-port input/output. Push-pull design structure.
P03	7	4	P-port input/output. Push-pull design structure.
P04	8	5	P-port input/output. Push-pull design structure.
P05	9	6	P-port input/output. Push-pull design structure.
P06	10	7	P-port input/output. Push-pull design structure.
P07	11	8	P-port input/output. Push-pull design structure.
GND	12	9	Ground
P10	13	10	P-port input/output. Push-pull design structure.
P11	14	11	P-port input/output. Push-pull design structure.
P12	15	12	P-port input/output. Push-pull design structure.
P13	16	13	P-port input/output. Push-pull design structure.
P14	17	14	P-port input/output. Push-pull design structure.
P15	18	15	P-port input/output. Push-pull design structure.
P16	19	16	P-port input/output. Push-pull design structure.
P17	20	17	P-port input/output. Push-pull design structure.
A0	21	18	Address input 0. Connect directly to $V_{CC}$ or ground.
SCL	22	19	Serial clock bus. Connect to $V_{CC}$ through a pullup resistor.
SDA	23	20	Serial data bus. Connect to $V_{CC}$ through a pullup resistor.
$V_{CC}$	24	21	Supply voltage

## 6 Specifications

### 6.1 Absolute Maximum Ratings<sup>(1)</sup>

over operating free-air temperature range (unless otherwise noted)

		MIN	MAX	UNIT
V <sub>CC</sub>	Supply voltage range	−0.5	6	V
V <sub>I</sub>	Input voltage range <sup>(2)</sup>	−0.5	6	V
V <sub>O</sub>	Output voltage range <sup>(2)</sup>	−0.5	6	V
I <sub>IK</sub>	Input clamp current	V <sub>I</sub> < 0	−20	mA
I <sub>OK</sub>	Output clamp current	V <sub>O</sub> < 0	−20	mA
I <sub>IOK</sub>	Input/output clamp current	V <sub>O</sub> < 0 or V <sub>O</sub> > V <sub>CC</sub>	±20	mA
I <sub>OL</sub>	Continuous output low current	V <sub>O</sub> = 0 to V <sub>CC</sub>	50	mA
I <sub>OH</sub>	Continuous output high current	V <sub>O</sub> = 0 to V <sub>CC</sub>	−50	mA
I <sub>CC</sub>	Continuous current through GND		−250	mA
	Continuous current through V <sub>CC</sub>		160	
T <sub>stg</sub>	Storage temperature range	−65	150	°C

- (1) Stresses beyond those listed under *Absolute Maximum Ratings* may cause permanent damage to the device. These are stress ratings only, and functional operation of the device at these or any other conditions beyond those indicated under *Recommended Operating Conditions* is not implied. Exposure to absolute-maximum-rated conditions for extended periods may affect device reliability.
- (2) The input negative-voltage and output voltage ratings may be exceeded if the input and output current ratings are observed.

### 6.2 ESD Ratings

		MIN	MAX	UNIT	
V <sub>(ESD)</sub>	Electrostatic discharge	Human body model (HBM), per ANSI/ESDA/JEDEC JS-001, all pins <sup>(1)</sup>	0	2000	V
		Charged device model (CDM), per JEDEC specification JESD22-C101 or ANSI/ESDA/JEDEC JS-002, all pins <sup>(2)</sup>	0	1000	

- (1) JEDEC document JEP155 states that 500-V HBM allows safe manufacturing with a standard ESD control process.
- (2) JEDEC document JEP157 states that 250-V CDM allows safe manufacturing with a standard ESD control process.

### 6.3 Recommended Operating Conditions

		MIN	MAX	UNIT	
V <sub>CC</sub>	Supply voltage	2.3	5.5	V	
V <sub>IH</sub>	High-level input voltage	SCL, SDA	0.7 × V <sub>CC</sub>	5.5	V
		A2–A0, P07–P00, P17–P10	0.7 × V <sub>CC</sub>	5.5	
V <sub>IL</sub>	Low-level input voltage	SCL, SDA	−0.5	0.3 × V <sub>CC</sub>	V
		A2–A0, P07–P00, P17–P10	−0.5	0.3 × V <sub>CC</sub>	
I <sub>OH</sub>	High-level output current	P07–P00, P17–P10	−10	mA	
I <sub>OL</sub>	Low-level output current	P07–P00, P17–P10	25	mA	
T <sub>A</sub>	Operating free-air temperature	−40	85	°C	

## 6.4 Thermal Information

THERMAL METRIC <sup>(1)</sup>		PCA9555			UNIT
		DB (SSOP)	DBQ (QSOP)	DGV (TVSOP)	
		24 PINS	24 PINS	24 PINS	
$R_{\theta JA}$	Junction-to-ambient thermal resistance	81.1	81.8	105.4	°C/W
$R_{\theta JC(top)}$	Junction-to-case (top) thermal resistance	41.5	39.3	36.7	°C/W
$R_{\theta JB}$	Junction-to-board thermal resistance	40.0	36.0	50.8	°C/W
$\Psi_{JT}$	Junction-to-top characterization parameter	9.9	7.6	2.4	°C/W
$\Psi_{JB}$	Junction-to-board characterization parameter	39.6	35.6	50.3	°C/W

(1) For more information about traditional and new thermal metrics, see the [Semiconductor and IC Package Thermal Metrics](#) application report.

## 6.5 Thermal Information

THERMAL METRIC <sup>(1)</sup>		PCA9555			UNIT
		DW (SOIC)	PW (TSSOP)	RGE (QFN)	
		24 PINS	24 PINS	24 PINS	
$R_{\theta JA}$	Junction-to-ambient thermal resistance	66.7	91.0	43.6	°C/W
$R_{\theta JC(top)}$	Junction-to-case (top) thermal resistance	36.7	35.5	37.8	°C/W
$R_{\theta JB}$	Junction-to-board thermal resistance	36.7	46.1	21.0	°C/W
$\Psi_{JT}$	Junction-to-top characterization parameter	13.1	2.8	0.9	°C/W
$\Psi_{JB}$	Junction-to-board characterization parameter	36.4	45.7	21.0	°C/W
$R_{\theta JC(bot)}$	Junction-to-case (bottom) thermal resistance	n/a	n/a	5.4	°C/W

(1) For more information about traditional and new thermal metrics, see the [Semiconductor and IC Package Thermal Metrics](#) application report.

## 6.6 Electrical Characteristics

over recommended operating free-air temperature range (unless otherwise noted)

PARAMETER		TEST CONDITIONS	V <sub>CC</sub>	MIN	TYP <sup>(1)</sup>	MAX	UNIT			
V <sub>IK</sub>	Input diode clamp voltage	I <sub>I</sub> = -18 mA	2.3 V to 5.5 V	-1.2			V			
V <sub>POR</sub>	Power-on reset voltage	V <sub>I</sub> = V <sub>CC</sub> or GND, I <sub>O</sub> = 0	V <sub>POR</sub>		1.5	1.65	V			
V <sub>OH</sub>	P-port high-level output voltage <sup>(2)</sup>	I <sub>OH</sub> = -8 mA	2.3 V	1.8			V			
			3 V	2.6						
			4.75 V	4.1						
		I <sub>OH</sub> = -10 mA	2.3 V	1.7						
			3 V	2.5						
			4.75 V	4						
I <sub>OL</sub>	SDA	V <sub>OL</sub> = 0.4 V	2.3 V to 5.5 V	3			mA			
	P port <sup>(3)</sup>	V <sub>OL</sub> = 0.5 V		8	20					
		V <sub>OL</sub> = 0.7 V		10	24					
	$\overline{\text{INT}}$	V <sub>OL</sub> = 0.4 V		3						
I <sub>I</sub>	SCL, SDA	V <sub>I</sub> = V <sub>CC</sub> or GND	2.3 V to 5.5 V			±1	μA			
	A2–A0					±1				
I <sub>IH</sub>	P port	V <sub>I</sub> = V <sub>CC</sub>	2.3 V to 5.5 V			1	μA			
I <sub>IL</sub>	P port	V <sub>I</sub> = GND	2.3 V to 5.5 V			-100	μA			
I <sub>CC</sub>	Operating mode	V <sub>I</sub> = V <sub>CC</sub> or GND, I <sub>O</sub> = 0, I/O = inputs, f <sub>SCL</sub> = 400 kHz, No load	5.5 V		100	200	μA			
			3.6 V		30	75				
			2.7 V		20	50				
	Standby mode	Low inputs	V <sub>I</sub> = GND, I <sub>O</sub> = 0, I/O = inputs, f <sub>SCL</sub> = 0 kHz, No load	5.5 V		1.1	1.5	mA		
				3.6 V		0.7	1.3			
				2.7 V		0.5	1			
				High inputs	V <sub>I</sub> = V <sub>CC</sub> , I <sub>O</sub> = 0, I/O = inputs, f <sub>SCL</sub> = 0 kHz, No load	5.5 V		0.5	1	μA
						3.6 V		0.4	0.9	
2.7 V		0.25	0.8							
ΔI <sub>CC</sub>	Additional current in standby mode	One input at V <sub>CC</sub> - 0.6 V, Other inputs at V <sub>CC</sub> or GND	2.3 V to 5.5 V			1.5	mA			
C <sub>I</sub>	SCL	V <sub>I</sub> = V <sub>CC</sub> or GND	2.3 V to 5.5 V		3	7	pF			
C <sub>IO</sub>	SDA	V <sub>IO</sub> = V <sub>CC</sub> or GND	2.3 V to 5.5 V		3	7	pF			
	P port				3.7	9.5				

(1) All typical values are at nominal supply voltage (2.5-V, 3.3-V, or 5-V V<sub>CC</sub>) and T<sub>A</sub> = 25°C.

(2) Each I/O must be externally limited to a maximum of 25 mA, and each octal (P07–P00 and P17–P10) must be limited to a maximum current of 100 mA, for a device total of 200 mA.

(3) The total current sourced by all I/Os must be limited to 160 mA (80 mA for P07–P00 and 80 mA for P17–P10).

## 6.7 I<sup>2</sup>C Interface Timing Requirements

over recommended operating free-air temperature range (unless otherwise noted) (see Figure 14)

		MIN	MAX	UNIT
<b>I<sup>2</sup>C BUS—STANDARD MODE</b>				
f <sub>scl</sub>	I <sup>2</sup> C clock frequency	0	100	kHz
t <sub>sch</sub>	I <sup>2</sup> C clock high time	4		μs
t <sub>scl</sub>	I <sup>2</sup> C clock low time	4.7		μs
t <sub>sp</sub>	I <sup>2</sup> C spike time		50	ns
t <sub>sds</sub>	I <sup>2</sup> C serial-data setup time	250		ns
t <sub>sdh</sub>	I <sup>2</sup> C serial-data hold time	0		ns
t <sub>icr</sub>	I <sup>2</sup> C input rise time		1000	ns
t <sub>icf</sub>	I <sup>2</sup> C input fall time		300	ns
t <sub>ocf</sub>	I <sup>2</sup> C output fall time	10-pF to 400-pF bus	300	ns
t <sub>buf</sub>	I <sup>2</sup> C bus free time between stop and start	4.7		μs
t <sub>sts</sub>	I <sup>2</sup> C start or repeated start condition setup	4.7		μs

## I<sup>2</sup>C Interface Timing Requirements (continued)

over recommended operating free-air temperature range (unless otherwise noted) (see [Figure 14](#))

		MIN	MAX	UNIT
$t_{sth}$	I <sup>2</sup> C start or repeated start condition hold	4		μs
$t_{sps}$	I <sup>2</sup> C stop condition setup	4		μs
$t_{vd(data)}$	Valid data time	SCL low to SDA output valid		3.45 μs
$t_{vd(ack)}$	Valid data time of ACK condition	ACK signal from SCL low to SDA (out) low		3.45 μs
$C_b^{(1)}$	I <sup>2</sup> C bus capacitive load		400	pF
<b>I<sup>2</sup>C BUS—FAST MODE</b>				
$f_{scl}$	I <sup>2</sup> C clock frequency	0	400	kHz
$t_{sch}$	I <sup>2</sup> C clock high time	0.6		μs
$t_{scl}$	I <sup>2</sup> C clock low time	1.3		μs
$t_{sp}$	I <sup>2</sup> C spike time		50	ns
$t_{sds}$	I <sup>2</sup> C serial-data setup time	100		ns
$t_{sdh}$	I <sup>2</sup> C serial-data hold time	0		ns
$t_{icr}$	I <sup>2</sup> C input rise time	20	300	ns
$t_{icf}$	I <sup>2</sup> C input fall time	$20 \times (V_{CC} / 5.5 \text{ V})$	300	ns
$t_{ocf}$	I <sup>2</sup> C output fall time	10-pF to 400-pF bus	$20 \times (V_{CC} / 5.5 \text{ V})$	300 ns
$t_{buf}$	I <sup>2</sup> C bus free time between stop and start	1.3		μs
$t_{sts}$	I <sup>2</sup> C start or repeated start condition setup	0.6		μs
$t_{sth}$	I <sup>2</sup> C start or repeated start condition hold	0.6		μs
$t_{sps}$	I <sup>2</sup> C stop condition setup	0.6		μs
$t_{vd(data)}$	Valid data time	SCL low to SDA output valid		0.9 μs
$t_{vd(ack)}$	Valid data time of ACK condition	ACK signal from SCL low to SDA (out) low		0.9 μs
$C_b^{(1)}$	I <sup>2</sup> C bus capacitive load		400	pF

(1)  $C_b$  = total capacitance of one bus line in pF.

## 6.8 Switching Characteristics

over recommended operating free-air temperature range,  $C_L \leq 100$  pF (unless otherwise noted) (see [Figure 14](#) and [Figure 15](#))

PARAMETER	FROM (INPUT)	TO (OUTPUT)	MIN	MAX	UNIT
$t_{iv}$	Interrupt valid time	P port		4	μs
$t_{ir}$	Interrupt reset delay time	SCL		4	μs
$t_{pv}$	Output data valid	SCL		200	ns
$t_{ps}$	Input data setup time	P port	150		ns
$t_{ph}$	Input data hold time	P port	1		μs

## 6.9 Typical Characteristics

$T_A = 25^\circ\text{C}$  (unless otherwise noted)

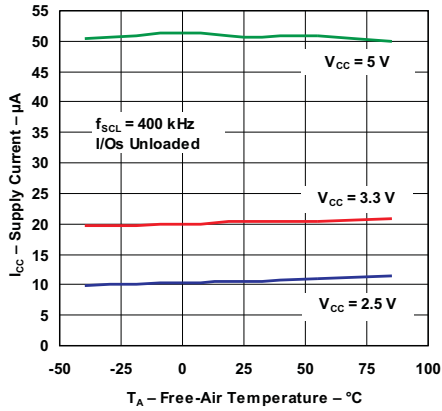


Figure 1. Supply Current vs Temperature

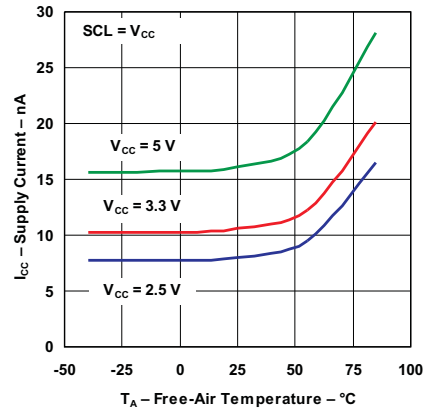


Figure 2. Standby Supply Current vs Temperature

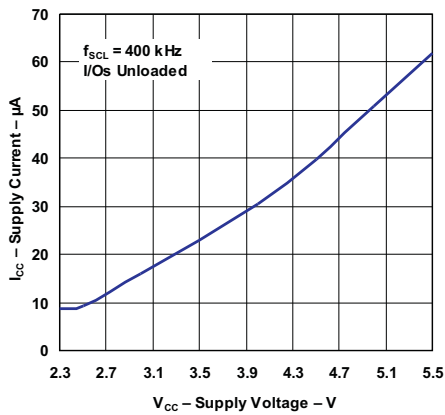


Figure 3. Supply Current vs Supply Voltage

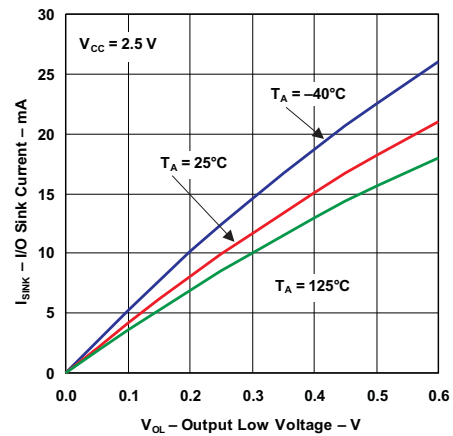


Figure 4. I/O Sink Current vs Output Low Voltage

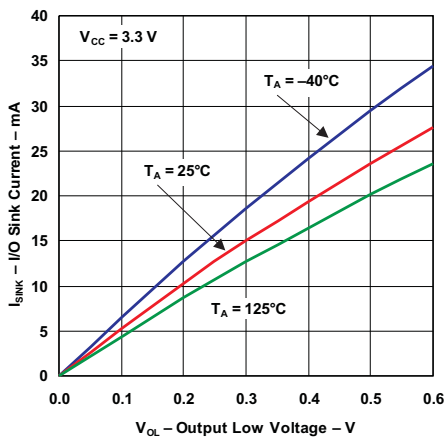


Figure 5. I/O Sink Current vs Output Low Voltage

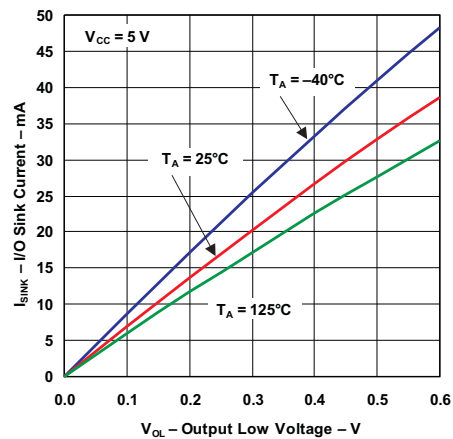


Figure 6. I/O Sink Current vs Output Low Voltage

Typical Characteristics (continued)

$T_A = 25^\circ\text{C}$  (unless otherwise noted)

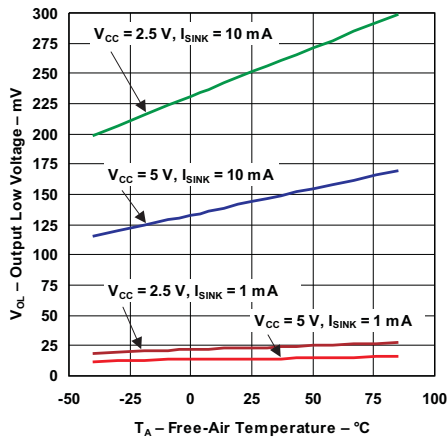


Figure 7. I/O Output Low Voltage vs Temperature

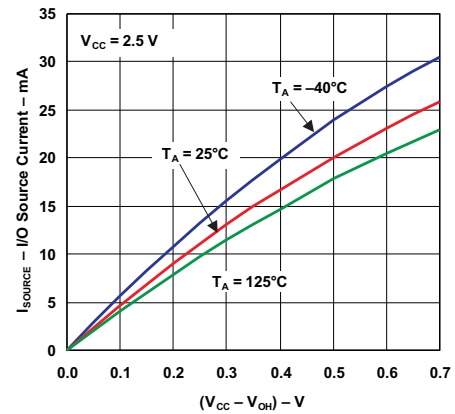


Figure 8. I/O Source Current vs Output High Voltage

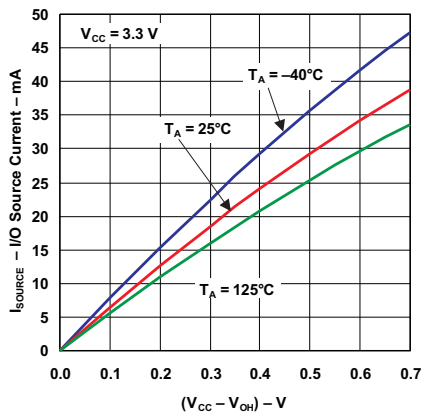


Figure 9. I/O Source Current vs Output High Voltage

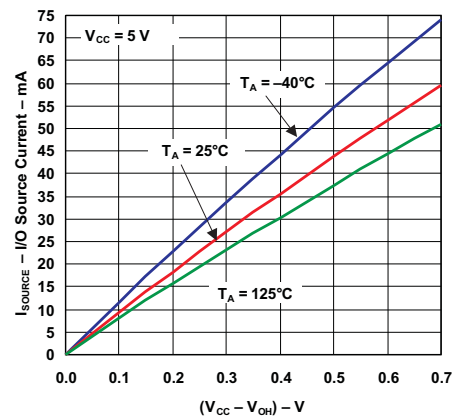


Figure 10. I/O Source Current vs Output High Voltage

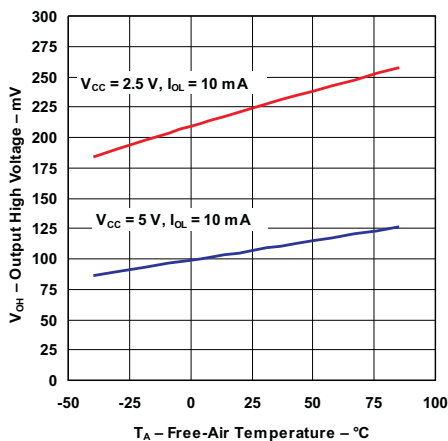


Figure 11. I/O High Voltage vs Temperature

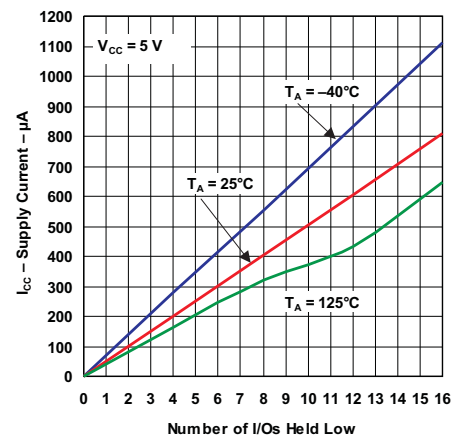
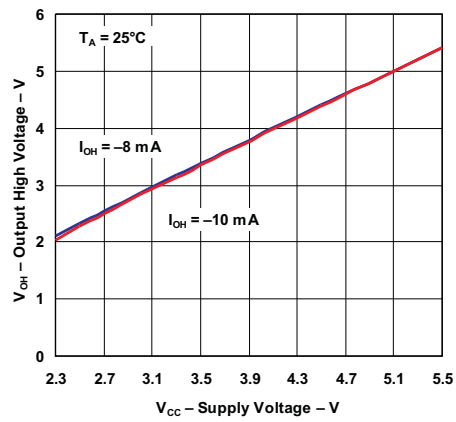
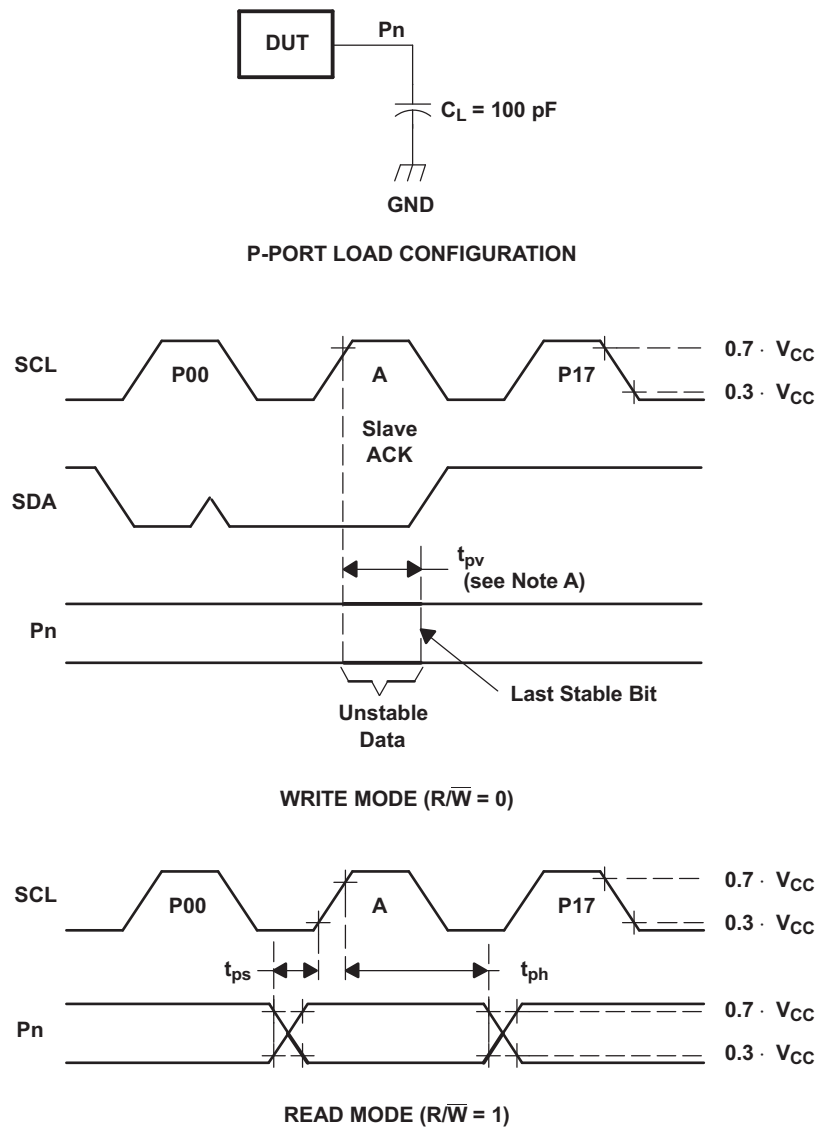


Figure 12. Supply Current vs Number Of I/Os Held Low

**Typical Characteristics (continued)**
 $T_A = 25^\circ\text{C}$  (unless otherwise noted)

**Figure 13. Output High Voltage vs Supply Voltage**



**Parameter Measurement Information (continued)**


- A.  $C_L$  includes probe and jig capacitance.
- B.  $t_{pv}$  is measured from  $0.7 \times V_{CC}$  on SCL to 50% I/O ( $P_n$ ) output.
- C. All inputs are supplied by generators having the following characteristics: PRR  $\leq$  10 MHz,  $Z_O = 50 \Omega$ ,  $t_r/t_f \leq 30$  ns.
- D. The outputs are measured one at a time, with one transition per measurement.
- E. All parameters and waveforms are not applicable to all devices.

**Figure 15. P-Port Load Circuit And Voltage Waveforms**

## 8 Detailed Description

### 8.1 Overview

The system master can reset the PCA9555 in the event of a timeout or other improper operation by utilizing the power-on reset feature, which puts the registers in their default state and initializes the I<sup>2</sup>C/SMBus state machine.

The PCA9555 open-drain interrupt ( $\overline{\text{INT}}$ ) output is activated when any input state differs from its corresponding Input Port register state and is used to indicate to the system master that an input state has changed.

$\overline{\text{INT}}$  can be connected to the interrupt input of a microcontroller. By sending an interrupt signal on this line, the remote I/O can inform the microcontroller if there is incoming data on its ports without having to communicate via the I<sup>2</sup>C bus. Thus, the PCA9555 can remain a simple slave device.

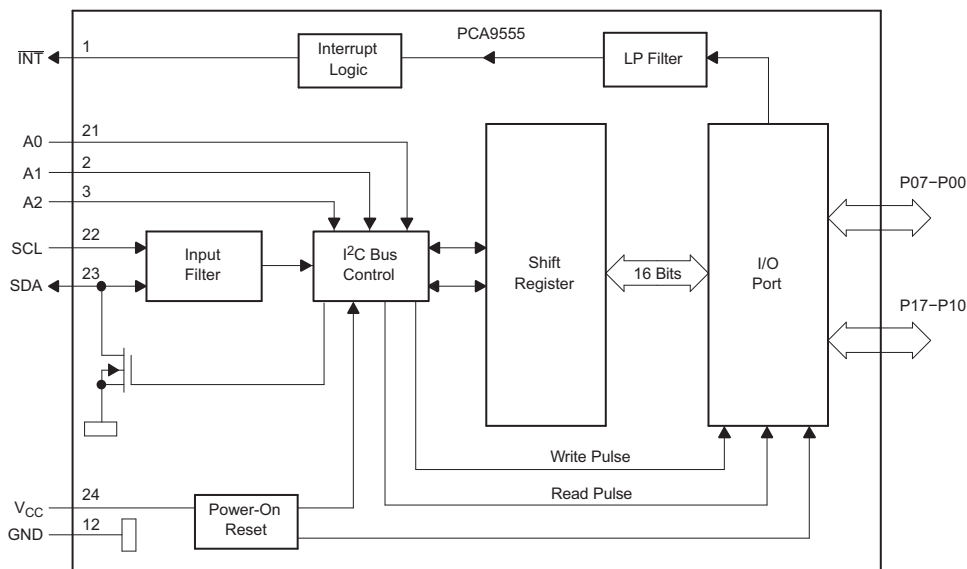
The device outputs (latched) have high-current drive capability for directly driving LEDs.

Although pin-to-pin and I<sup>2</sup>C-address is compatible with the PCF8575, software changes are required due to the enhancements.

The PCA9555 is identical to the PCA9535, except for the inclusion of the internal I/O pullup resistor, which pulls the I/O to a default high when configured as an input and undriven.

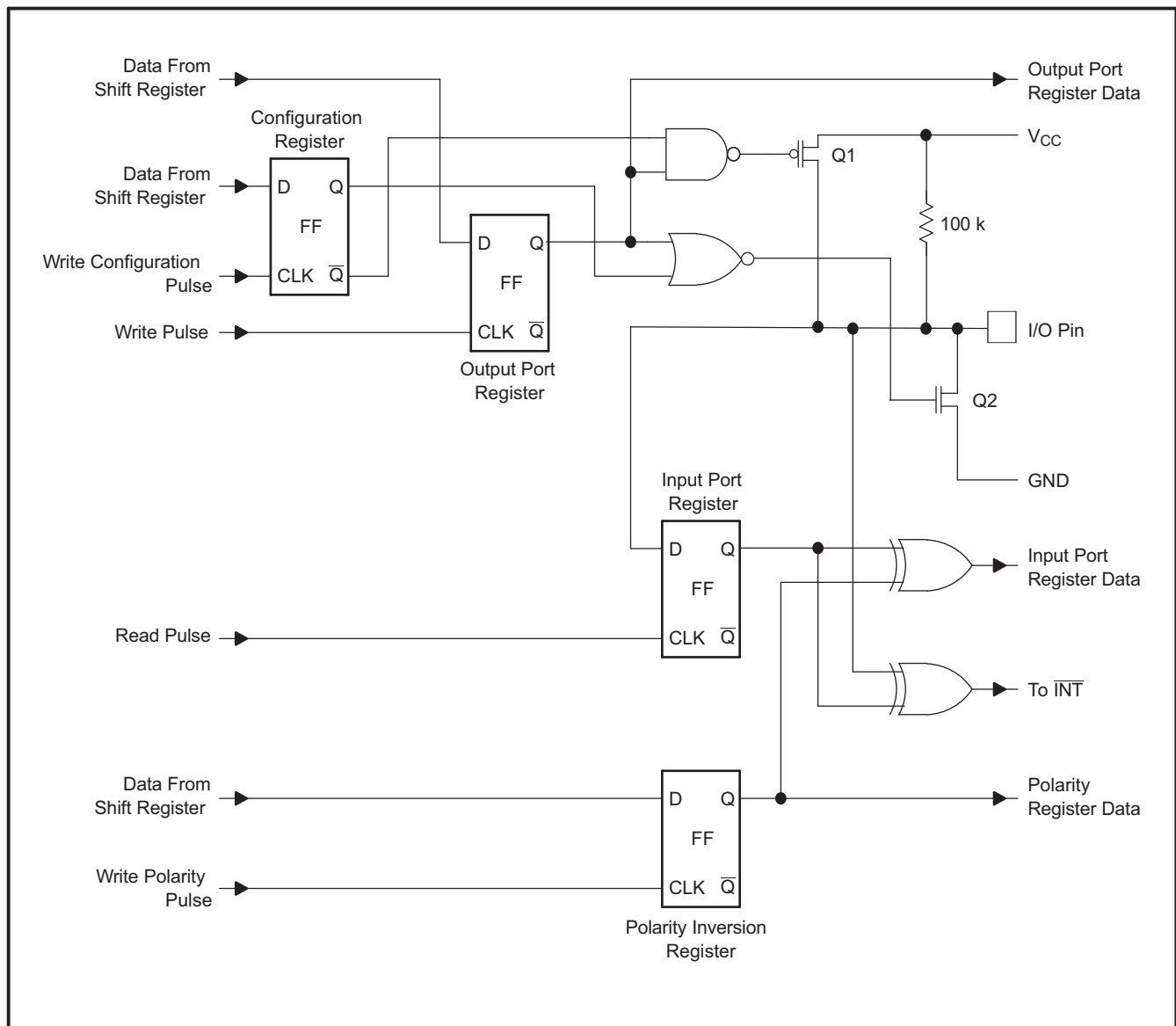
Three hardware pins (A0, A1, and A2) are used to program and vary the fixed I<sup>2</sup>C address and allow up to eight devices to share the same I<sup>2</sup>C bus or SMBus. The fixed I<sup>2</sup>C address of the PCA9555 is the same as the PCF8575, PCF8575C, and PCF8574, allowing up to eight of these devices in any combination to share the same I<sup>2</sup>C bus or SMBus.

### 8.2 Functional Block Diagram



- A. Pin numbers shown are for DB, DBQ, DGV, DW, and PW packages.
- B. All I/Os are set to inputs at reset.

Figure 16. Logic Diagram

**Functional Block Diagram (continued)**


(1) At power-on reset, all registers return to default values.

**Figure 17. Simplified Schematic Of P-Port I/Os**

## 8.3 Device Features

### 8.3.1 Power-On Reset

When power (from 0 V) is applied to  $V_{CC}$ , an internal power-on reset holds the PCA9555 in a reset condition until  $V_{CC}$  has reached  $V_{POR}$ . At that point, the reset condition is released and the PCA9555 registers and I<sup>2</sup>C/SMBus state machine initialize to their default states. After that,  $V_{CC}$  must be lowered to 0 V and then back up to the operating voltage for a power-reset cycle.

Refer to the [Power-On Reset Errata](#) section.

## Device Features (continued)

### 8.3.2 I/O Port

When an I/O is configured as an input, FETs Q1 and Q2 (in [Figure 17](#)) are off, creating a high-impedance input. The input voltage may be raised above  $V_{CC}$  to a maximum of 5.5 V.

If the I/O is configured as an output, Q1 or Q2 is enabled, depending on the state of the Output Port register. In this case, there are low-impedance paths between the I/O pin and either  $V_{CC}$  or GND. The external voltage applied to this I/O pin should not exceed the recommended levels for proper operation.

## 8.4 Device Functional Modes

### 8.4.1 Interrupt ( $\overline{INT}$ ) Output

An interrupt is generated by any rising or falling edge of the port inputs in the input mode. After time,  $t_{iv}$ , the signal  $\overline{INT}$  is valid. Resetting the interrupt circuit is achieved when data on the port is changed to the original setting, data is read from the port that generated the interrupt. Resetting occurs in the read mode at the acknowledge (ACK) or not acknowledge (NACK) bit after the rising edge of the SCL signal.

Interrupts that occur during the ACK or NACK clock pulse can be lost (or be very short) due to the resetting of the interrupt during this pulse. Each change of the I/Os after resetting is detected and is transmitted as  $\overline{INT}$ . Writing to another device does not affect the interrupt circuit, and a pin configured as an output cannot cause an interrupt. Changing an I/O from an output to an input may cause a false interrupt to occur, if the state of the pin does not match the contents of the Input Port register. Because each 8-pin port is read independently, the interrupt caused by port 0 is not cleared by a read of port 1 or vice versa.

The  $\overline{INT}$  output has an open-drain structure and requires pullup resistor to  $V_{CC}$ .

#### 8.4.1.1 Interrupt Errata

##### 8.4.1.1.1 INT Description

The INT will be improperly de-asserted if the following two conditions occur:

- i. The last I<sup>2</sup>C command byte (register pointer) written to the device was 00h.

---

#### NOTE

This generally means the last operation with the device was a Read of the input register. However, the command byte may have been written with 00h without ever going on to read the input register. After reading from the device, if no other command byte written, it will remain 00h.

---

- ii. Any other slave device on the I<sup>2</sup>C bus acknowledges an address byte with the R/W bit set high

##### 8.4.1.1.2 System Impact

Can cause improper interrupt handling as the Master will see the interrupt as being cleared.

##### 8.4.1.1.3 System Workaround

Minor software change: User must change command byte to something besides 00h after a Read operation to the PCA9555 device or before reading from another slave device.

---

#### NOTE

Software change will be compatible with other versions (competition and TI redesigns) of this device.

---

## 8.5 Programming

### 8.5.1 I<sup>2</sup>C Interface

The bidirectional I<sup>2</sup>C bus consists of the serial clock (SCL) and serial data (SDA) lines. Both lines must be connected to a positive supply via a pullup resistor when connected to the output stages of a device. Data transfer may be initiated only when the bus is not busy.

I<sup>2</sup>C communication with this device is initiated by a master sending a Start condition, a high-to-low transition on the SDA input/output while the SCL input is high (see Figure 18). After the Start condition, the device address byte is sent, MSB first, including the data direction bit (R/W). This device does not respond to the general call address.

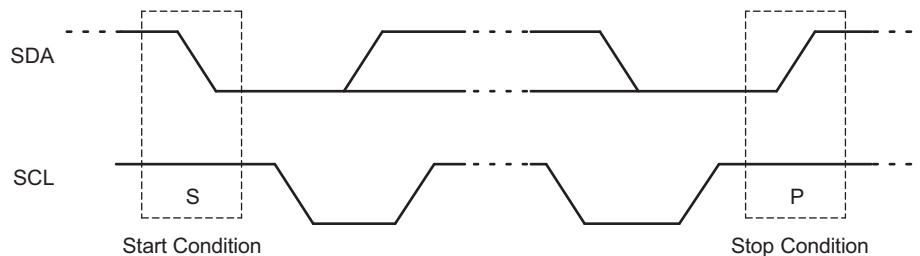
After receiving the valid address byte, this device responds with an ACK, a low on the SDA input/output during the high of the ACK-related clock pulse. The address inputs (A0–A2) of the slave device must not be changed between the Start and Stop conditions.

On the I<sup>2</sup>C bus, only one data bit is transferred during each clock pulse. The data on the SDA line must remain stable during the high pulse of the clock period, as changes in the data line at this time are interpreted as control commands (Start or Stop) (see Figure 19).

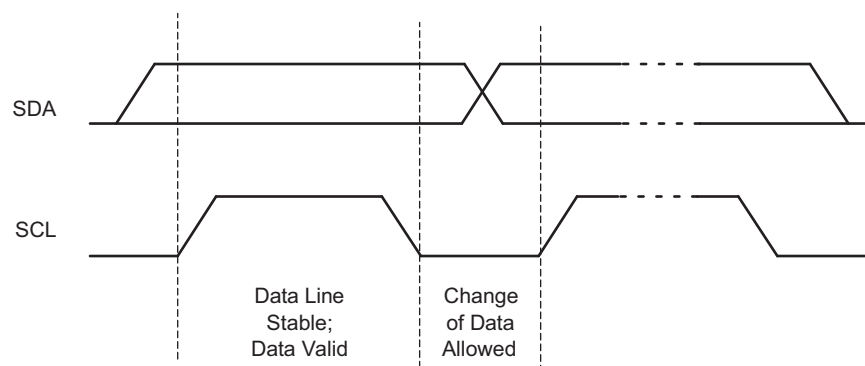
A Stop condition, a low-to-high transition on the SDA input/output while the SCL input is high, is sent by the master (see Figure 18).

Any number of data bytes can be transferred from the transmitter to the receiver between the Start and the Stop conditions. Each byte of eight bits is followed by one ACK bit. The transmitter must release the SDA line before the receiver can send an ACK bit. The device that acknowledges must pull down the SDA line during the ACK clock pulse so that the SDA line is stable low during the high pulse of the ACK-related clock period (see Figure 20). When a slave receiver is addressed, it must generate an ACK after each byte is received. Similarly, the master must generate an ACK after each byte that it receives from the slave transmitter. Setup and hold times must be met to ensure proper operation.

A master receiver signals an end of data to the slave transmitter by not generating an acknowledge (NACK) after the last byte has been clocked out of the slave. This is done by the master receiver by holding the SDA line high. In this event, the transmitter must release the data line to enable the master to generate a Stop condition.

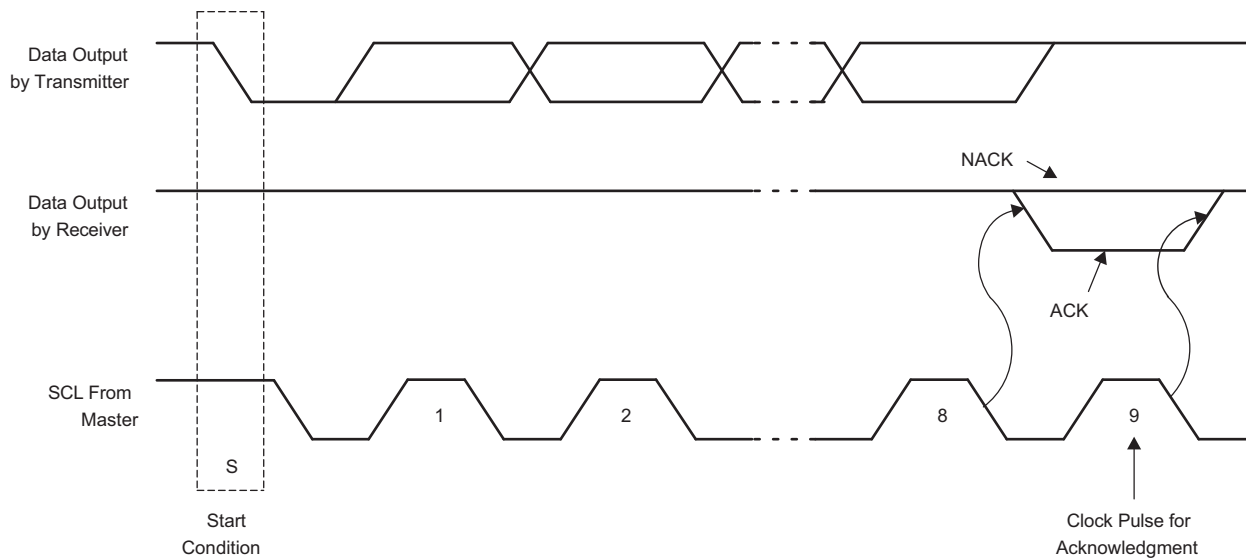


**Figure 18. Definition Of Start And Stop Conditions**



**Figure 19. Bit Transfer**

**Programming (continued)**



**Figure 20. Acknowledgment On I<sup>2</sup>C Bus**

**8.5.2 Register Map**

**Table 1. Interface Definition**

BYTE	BIT							
	7 (MSB)	6	5	4	3	2	1	0 (LSB)
I <sup>2</sup> C slave address	L	H	L	L	A2	A1	A0	R/ $\bar{W}$
P0x I/O data bus	P07	P06	P05	P04	P03	P02	P01	P00
P1x I/O data bus	P17	P16	P15	P14	P13	P12	P11	P10

### 8.5.2.1 Device Address

Figure 21 shows the address byte of the PCA9555.

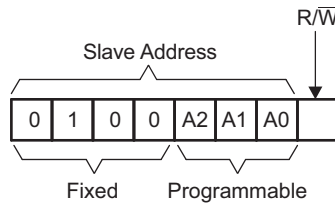


Figure 21. PCA9555 Address

Table 2. Address Reference

INPUTS			I <sup>2</sup> C BUS SLAVE ADDRESS
A2	A1	A0	
L	L	L	32 (decimal), 20 (hexadecimal)
L	L	H	33 (decimal), 21 (hexadecimal)
L	H	L	34 (decimal), 22 (hexadecimal)
L	H	H	35 (decimal), 23 (hexadecimal)
H	L	L	36 (decimal), 24 (hexadecimal)
H	L	H	37 (decimal), 25 (hexadecimal)
H	H	L	38 (decimal), 26 (hexadecimal)
H	H	H	39 (decimal), 27 (hexadecimal)

The last bit of the slave address defines the operation (read or write) to be performed. A high (1) selects a read operation, while a low (0) selects a write operation.

### 8.5.2.2 Control Register And Command Byte

Following the successful acknowledgment of the address byte, the bus master sends a command byte that is stored in the control register in the PCA9555. Three bits of this data byte state the operation (read or write) and the internal register (input, output, polarity inversion, or configuration) that will be affected. This register can be written or read through the I<sup>2</sup>C bus. The command byte is sent only during a write transmission.

Once a command byte has been sent, the register that was addressed continues to be accessed by reads until a new command byte has been sent.

Figure 22. Control Register Bits

7	6	5	4	3	2	1	0
0	0	0	0	0	B2	B1	B0

Table 3. Command Byte

CONTROL REGISTER BITS			COMMAND BYTE (HEX)	REGISTER	PROTOCOL	POWER-UP DEFAULT
B2	B1	B0				
0	0	0	0x00	Input Port 0	Read byte	xxxx xxxx
0	0	1	0x01	Input Port 1	Read byte	xxxx xxxx
0	1	0	0x02	Output Port 0	Read/write byte	1111 1111
0	1	1	0x03	Output Port 1	Read/write byte	1111 1111
1	0	0	0x04	Polarity Inversion Port 0	Read/write byte	0000 0000
1	0	1	0x05	Polarity Inversion Port 1	Read/write byte	0000 0000
1	1	0	0x06	Configuration Port 0	Read/write byte	1111 1111
1	1	1	0x07	Configuration Port 1	Read/write byte	1111 1111

### 8.5.2.3 Register Descriptions

The Input Port registers (registers 0 and 1) reflect the incoming logic levels of the pins, regardless of whether the pin is defined as an input or an output by the Configuration register. It only acts on read operation. Writes to these registers have no effect. The default value, X, is determined by the externally applied logic level.

Before a read operation, a write transmission is sent with the command byte to indicate to the I<sup>2</sup>C device that the Input Port register will be accessed next.

**Table 4. Registers 0 And 1 (Input Port Registers)**

<b>Bit</b>	<b>I0.7</b>	<b>I0.6</b>	<b>I0.5</b>	<b>I0.4</b>	<b>I0.3</b>	<b>I0.2</b>	<b>I0.1</b>	<b>I0.0</b>
<b>Default</b>	X	X	X	X	X	X	X	X
<b>Bit</b>	<b>I1.7</b>	<b>I1.6</b>	<b>I1.5</b>	<b>I1.4</b>	<b>I1.3</b>	<b>I1.2</b>	<b>I1.1</b>	<b>I1.0</b>
<b>Default</b>	X	X	X	X	X	X	X	X

The Output Port registers (registers 2 and 3) show the outgoing logic levels of the pins defined as outputs by the Configuration register. Bit values in this register have no effect on pins defined as inputs. In turn, reads from this register reflect the value that is in the flip-flop controlling the output selection, not the actual pin value.

**Table 5. Registers 2 And 3 (Output Port Registers)**

<b>Bit</b>	<b>O0.7</b>	<b>O0.6</b>	<b>O0.5</b>	<b>O0.4</b>	<b>O0.3</b>	<b>O0.2</b>	<b>O0.1</b>	<b>O0.0</b>
<b>Default</b>	1	1	1	1	1	1	1	1
<b>Bit</b>	<b>O1.7</b>	<b>O1.6</b>	<b>O1.5</b>	<b>O1.4</b>	<b>O1.3</b>	<b>O1.2</b>	<b>O1.1</b>	<b>O1.0</b>
<b>Default</b>	1	1	1	1	1	1	1	1

The Polarity Inversion registers (registers 4 and 5) allow polarity inversion of pins defined as inputs by the Configuration register. If a bit in this register is set (written with 1), the corresponding port pin's polarity is inverted. If a bit in this register is cleared (written with a 0), the corresponding port pin's original polarity is retained.

**Table 6. Registers 4 And 5 (Polarity Inversion Registers)**

<b>Bit</b>	<b>N0.7</b>	<b>N0.6</b>	<b>N0.5</b>	<b>N0.4</b>	<b>N0.3</b>	<b>N0.2</b>	<b>N0.1</b>	<b>N0.0</b>
<b>Default</b>	0	0	0	0	0	0	0	0
<b>Bit</b>	<b>N1.7</b>	<b>N1.6</b>	<b>N1.5</b>	<b>N1.4</b>	<b>N1.3</b>	<b>N1.2</b>	<b>N1.1</b>	<b>N1.0</b>
<b>Default</b>	0	0	0	0	0	0	0	0

The Configuration registers (registers 6 and 7) configure the directions of the I/O pins. If a bit in this register is set to 1, the corresponding port pin is enabled as an input with a high-impedance output driver. If a bit in this register is cleared to 0, the corresponding port pin is enabled as an output.

**Table 7. Registers 6 And 7 (Configuration Registers)**

<b>Bit</b>	<b>C0.7</b>	<b>C0.6</b>	<b>C0.5</b>	<b>C0.4</b>	<b>C0.3</b>	<b>C0.2</b>	<b>C0.1</b>	<b>C0.0</b>
<b>Default</b>	1	1	1	1	1	1	1	1
<b>Bit</b>	<b>C1.7</b>	<b>C1.6</b>	<b>C1.5</b>	<b>C1.4</b>	<b>C1.3</b>	<b>C1.2</b>	<b>C1.1</b>	<b>C1.0</b>
<b>Default</b>	1	1	1	1	1	1	1	1

### 8.5.2.4 Bus Transactions

Data is exchanged between the master and the PCA9555 through write and read commands.

#### 8.5.2.4.1 Writes

Data is transmitted to the PCA9555 by sending the device address and setting the least-significant bit to a logic 0 (see Figure 21 for device address). The command byte is sent after the address and determines which register receives the data that follows the command byte.

The eight registers within the PCA9555 are configured to operate as four register pairs. The four pairs are input ports, output ports, polarity inversion ports, and configuration ports. After sending data to one register, the next data byte is sent to the other register in the pair (see Figure 23 and Figure 24). For example, if the first byte is sent to output port (register 3), the next byte is stored in Output Port 0 (register 2).

There is no limitation on the number of data bytes sent in one write transmission. In this way, each 8-bit register may be updated independently of the other registers.

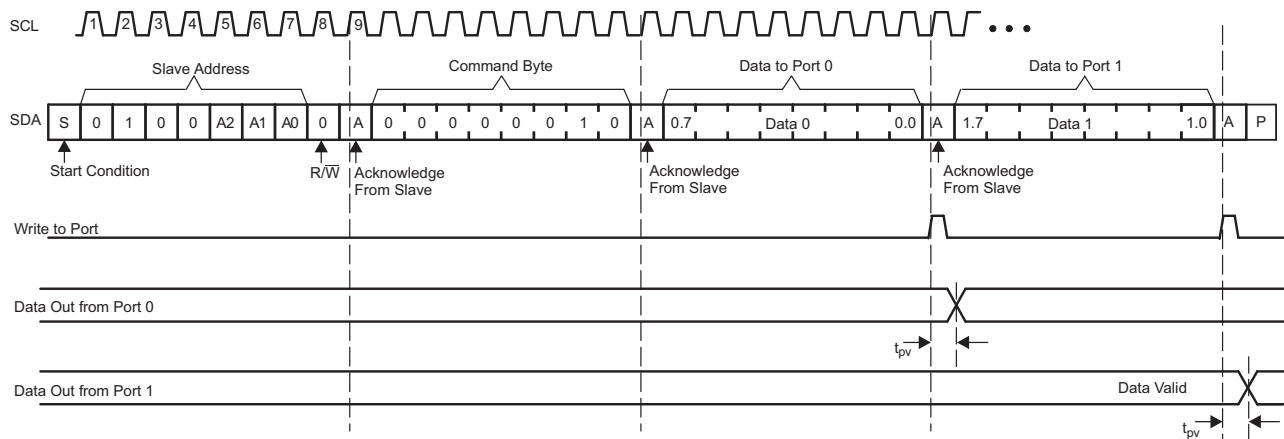


Figure 23. Write To Output Port Registers

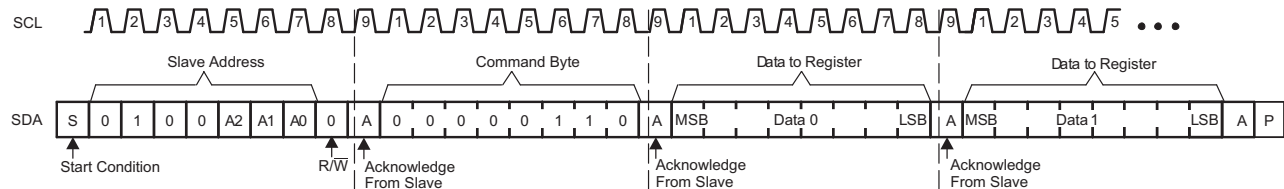


Figure 24. Write To Configuration Registers

#### 8.5.2.4.2 Reads

The bus master first must send the PCA9555 address with the least-significant bit set to a logic 0 (see Figure 21 for device address). The command byte is sent after the address and determines which register is accessed. After a restart, the device address is sent again, but this time, the least-significant bit is set to a logic 1. Data from the register defined by the command byte then is sent by the PCA9555 (see Figure 25 through Figure 27).

After a restart, the value of the register defined by the command byte matches the register being accessed when the restart occurred. For example, if the command byte references Input Port 1 before the restart, and the restart occurs when Input Port 0 is being read, the stored command byte changes to reference Input Port 0. The original command byte is forgotten. If a subsequent restart occurs, Input Port 0 is read first. Data is clocked into the register on the rising edge of the ACK clock pulse. After the first byte is read, additional bytes may be read, but the data now reflect the information in the other register in the pair. For example, if Input Port 1 is read, the next byte read is Input Port 0.

Data is clocked into the register on the rising edge of the ACK clock pulse. There is no limitation on the number of data bytes received in one read transmission, but when the final byte is received, the bus master must not acknowledge the data.

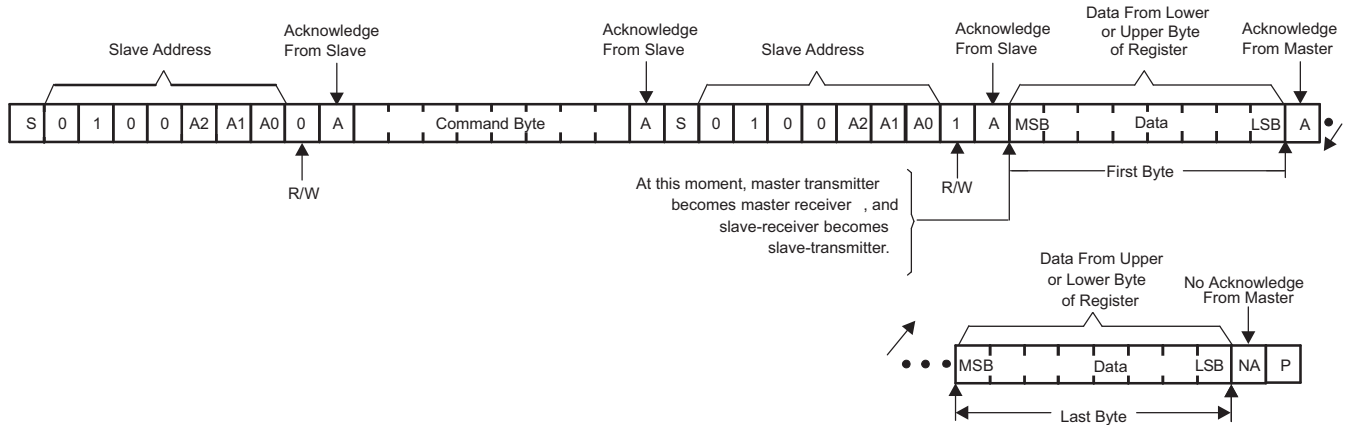
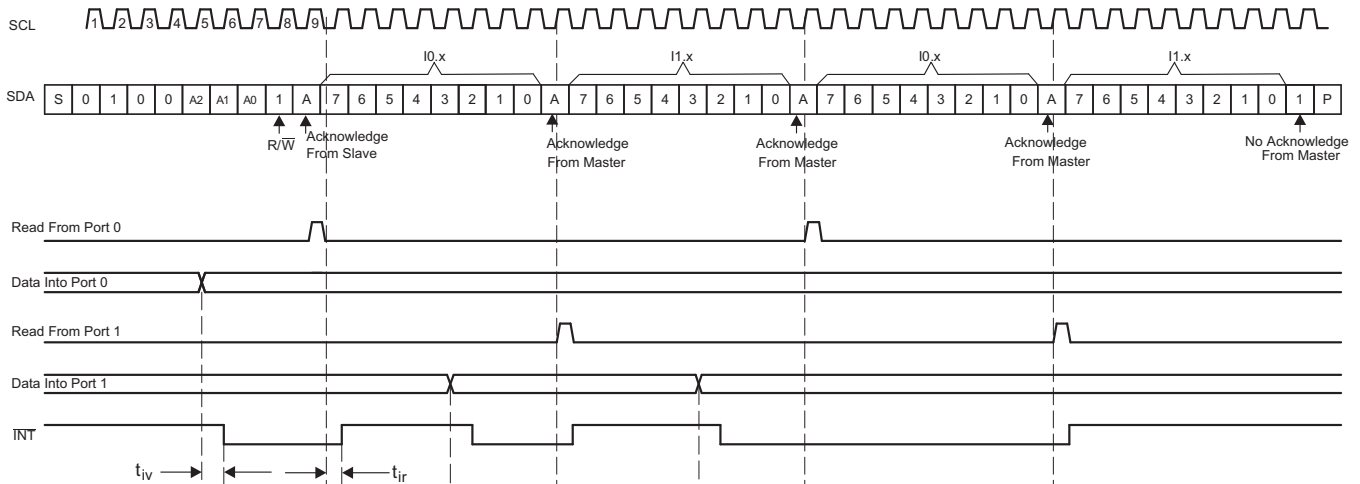
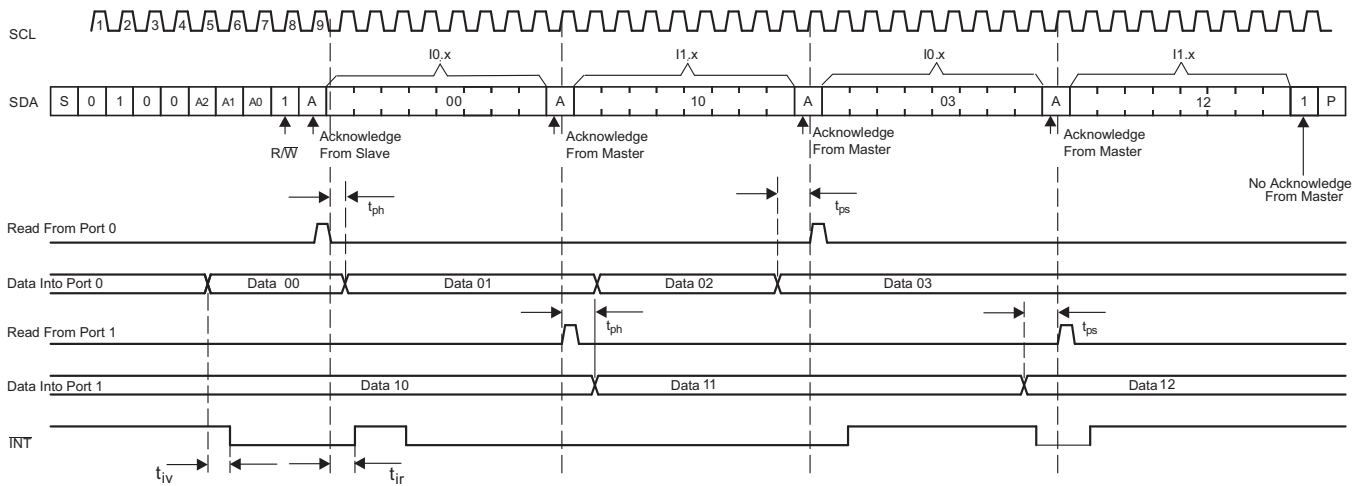


Figure 25. Read From Register



- A. Transfer of data can be stopped at any time by a Stop condition. When this occurs, data present at the latest acknowledge phase is valid (output mode). It is assumed that the command byte previously has been set to 00 (read Input Port register).
- B. This figure eliminates the command byte transfer, a restart, and slave address call between the initial slave address call and actual data transfer from the P port (see Figure 25 for these details).

Figure 26. Read Input Port Register, Scenario 1



- A. Transfer of data can be stopped at any time by a Stop condition. When this occurs, data present at the latest acknowledge phase is valid (output mode). It is assumed that the command byte previously has been set to 00 (read Input Port register).
- B. This figure eliminates the command byte transfer, a restart, and slave address call between the initial slave address call and actual data transfer from the P port (see [Figure 25](#) for these details).

**Figure 27. Read Input Port Register, Scenario 2**

## 9 Application and Implementation

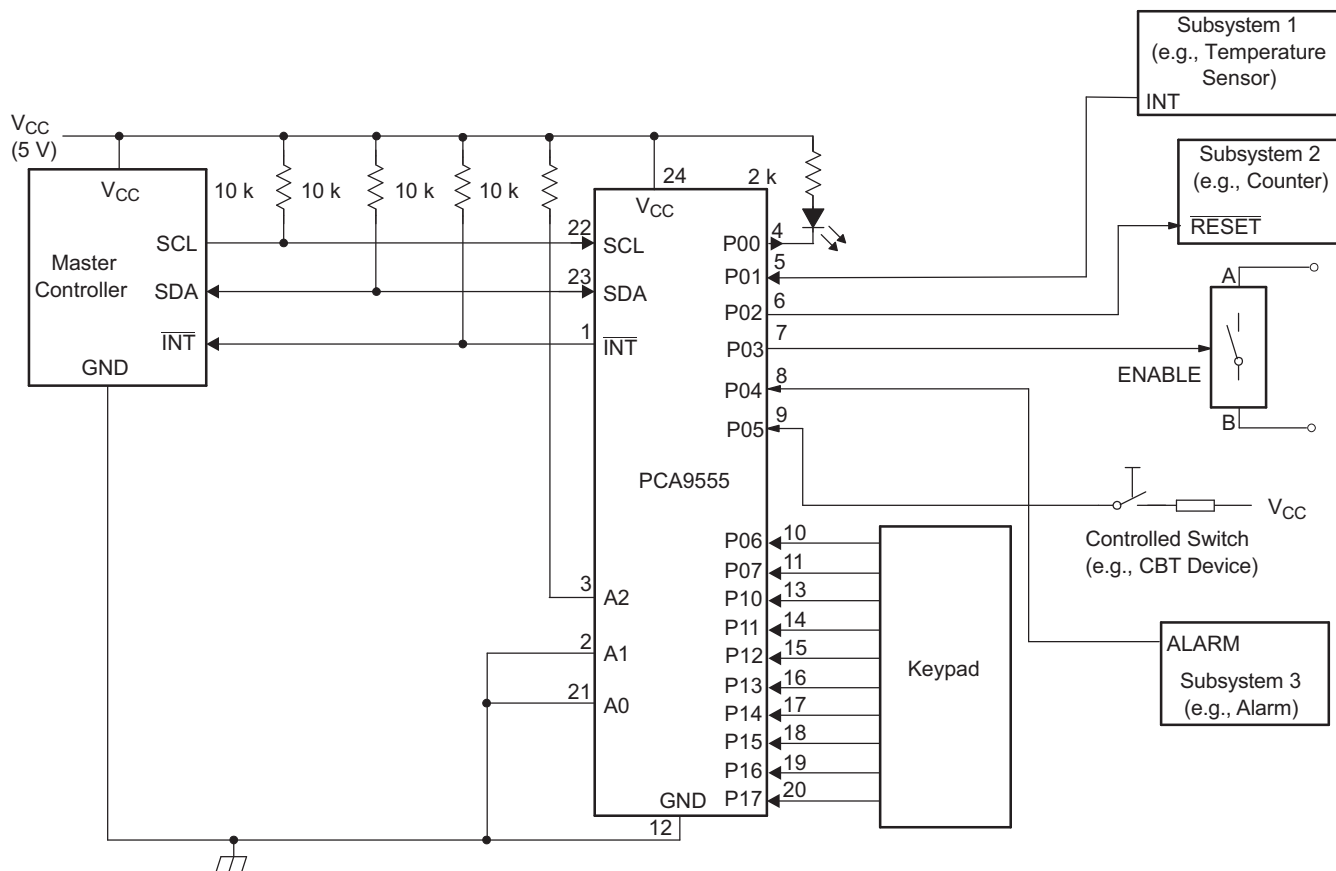
### NOTE

Information in the following applications sections is not part of the TI component specification, and TI does not warrant its accuracy or completeness. TI's customers are responsible for determining suitability of components for their purposes. Customers should validate and test their design implementation to confirm system functionality.

### 9.1 Application Information

### 9.2 Typical Application

Figure 28 shows an application in which the PCA9555 can be used.



- A. Device address is configured as 0100100 for this example.
- B. P00, P02, and P03 are configured as outputs.
- C. P01, P04–P07, and P10–P17 are configured as inputs.
- D. Pin numbers shown are for DB, DBQ, DGV, DW, and PW packages.

**Figure 28. Typical Application**

## Typical Application (continued)

### 9.2.1 Design Requirements

For this design example, use the parameters shown in [Table 8](#).

**Table 8. Design Parameters**

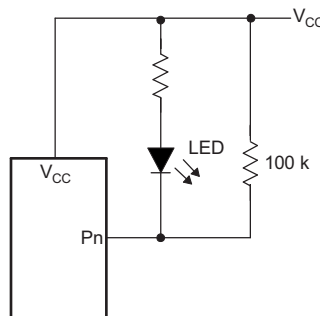
DESIGN PARAMETER	EXAMPLE VALUE
I <sup>2</sup> C and Subsystem Voltage (V <sub>CC</sub> )	5 V
Output current rating, P-port sinking (I <sub>OL</sub> )	25 mA
I <sup>2</sup> C bus clock (SCL) speed	400 kHz

### 9.2.2 Design Requirements

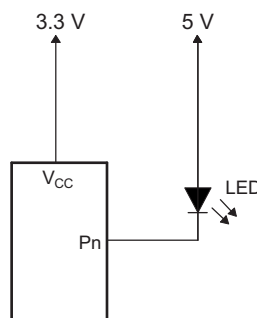
#### 9.2.2.1 Minimizing I<sub>CC</sub> When I/O Is Used To Control Led

When an I/O is used to control an LED, normally it is connected to V<sub>CC</sub> through a resistor as shown in [Figure 28](#). Because the LED acts as a diode, when the LED is off, the I/O V<sub>IN</sub> is about 1.2 V less than V<sub>CC</sub>. The ΔI<sub>CC</sub> parameter in Electrical Characteristics shows how I<sub>CC</sub> increases as V<sub>IN</sub> becomes lower than V<sub>CC</sub>. For battery-powered applications, it is essential that the voltage of I/O pins is greater than or equal to V<sub>CC</sub> when the LED is off to minimize current consumption.

[Figure 29](#) shows a high-value resistor in parallel with the LED. [Figure 30](#) shows V<sub>CC</sub> less than the LED supply voltage by at least 1.2 V. Both of these methods maintain the I/O V<sub>IN</sub> at or above V<sub>CC</sub> and prevent additional supply current consumption when the LED is off.

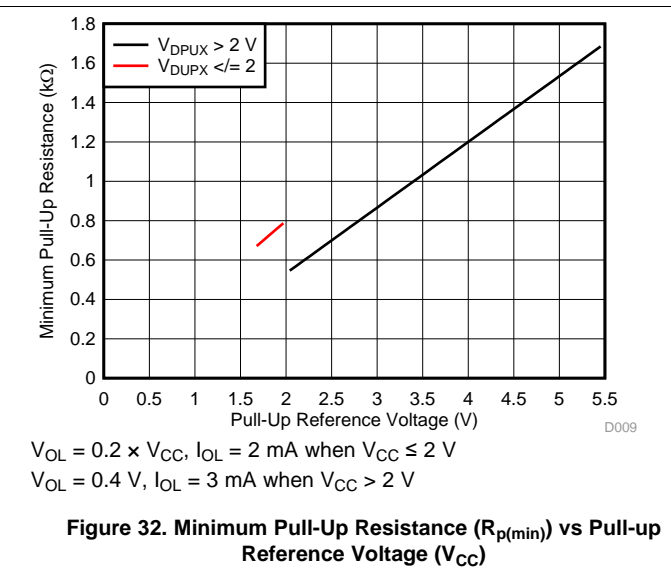
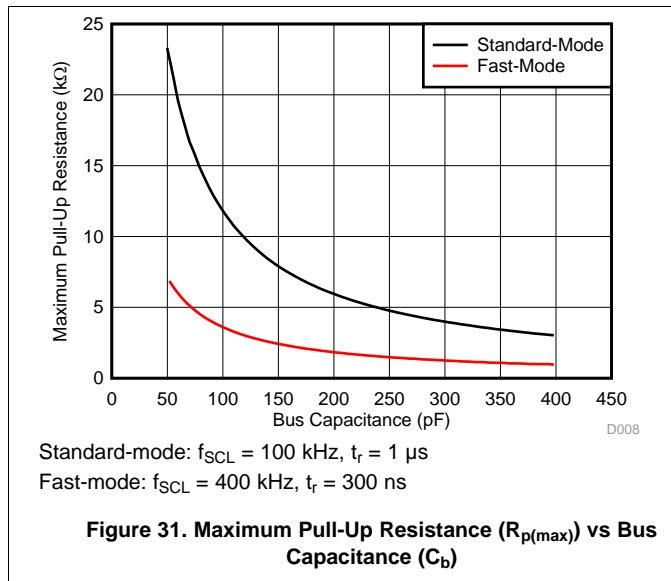


**Figure 29. High-Value Resistor In Parallel With Led**



**Figure 30. Device Supplied By Lower Voltage**

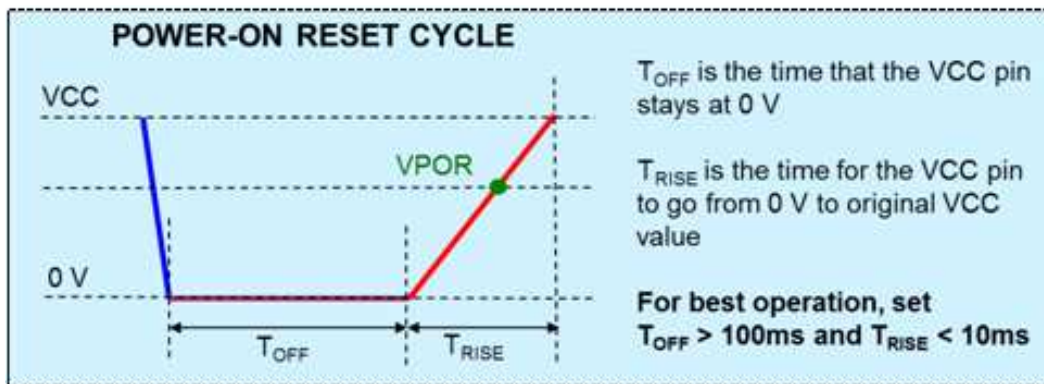
### 9.2.3 Application Curves



## 10 Power Supply Recommendations

### 10.1 Power-On Reset Errata

A power-on reset condition can be missed if the VCC ramps are outside specification listed below.



#### 10.1.1 System Impact

If ramp conditions are outside timing allowances above, POR condition can be missed, causing the device to lock up.

## 11 Layout

### 11.1 Layout Guidelines

For printed circuit board (PCB) layout of the PCA9555, common PCB layout practices must be followed, but additional concerns related to high-speed data transfer such as matched impedances and differential pairs are not a concern for I<sup>2</sup>C signal speeds.

In all PCB layouts, it is a best practice to avoid right angles in signal traces, to fan out signal traces away from each other upon leaving the vicinity of an integrated circuit (IC), and to use thicker trace widths to carry higher amounts of current that commonly pass through power and ground traces. By-pass and de-coupling capacitors are commonly used to control the voltage on the V<sub>CC</sub> pin, using a larger capacitor to provide additional power in the event of a short power supply glitch and a smaller capacitor to filter out high-frequency ripple. These capacitors must be placed as close to the PCA9555 as possible. These best practices are shown in the *Layout Example*.

For the layout example provided in the *Layout Example*, it is possible to fabricate a PCB with only 2 layers by using the top layer for signal routing and the bottom layer as a split plane for power (V<sub>CC</sub>) and ground (GND). However, a 4 layer board is preferable for boards with higher density signal routing. On a 4 layer PCB, it is common to route signals on the top and bottom layer, dedicate one internal layer to a ground plane, and dedicate the other internal layer to a power plane. In a board layout using planes or split planes for power and ground, vias are placed directly next to the surface mount component pad which needs to attach to V<sub>CC</sub>, or GND and the via is connected electrically to the internal layer or the other side of the board. Vias are also used when a signal trace needs to be routed to the opposite side of the board, but this technique is not demonstrated in the *Layout Example*.

### 11.2 Layout Example

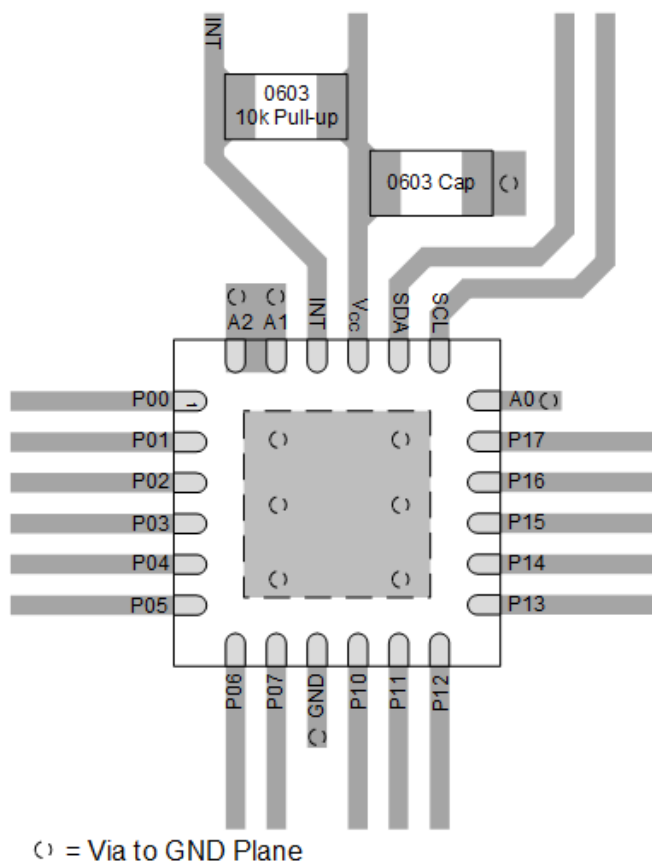


Figure 33. PCA9555 Example Layout

## 12 Device and Documentation Support

### 12.1 Receiving Notification of Documentation Updates

To receive notification of documentation updates, navigate to the device product folder on ti.com. In the upper right corner, click on *Alert me* to register and receive a weekly digest of any product information that has changed. For change details, review the revision history included in any revised document.

### 12.2 Community Resources

The following links connect to TI community resources. Linked contents are provided "AS IS" by the respective contributors. They do not constitute TI specifications and do not necessarily reflect TI's views; see TI's [Terms of Use](#).

**TI E2E™ Online Community** *TI's Engineer-to-Engineer (E2E) Community*. Created to foster collaboration among engineers. At e2e.ti.com, you can ask questions, share knowledge, explore ideas and help solve problems with fellow engineers.

**Design Support** *TI's Design Support* Quickly find helpful E2E forums along with design support tools and contact information for technical support.

### 12.3 Trademarks

E2E is a trademark of Texas Instruments.  
All other trademarks are the property of their respective owners.

### 12.4 Electrostatic Discharge Caution



This integrated circuit can be damaged by ESD. Texas Instruments recommends that all integrated circuits be handled with appropriate precautions. Failure to observe proper handling and installation procedures can cause damage.

ESD damage can range from subtle performance degradation to complete device failure. Precision integrated circuits may be more susceptible to damage because very small parametric changes could cause the device not to meet its published specifications.

### 12.5 Glossary

[SLYZ022](#) — *TI Glossary*.

This glossary lists and explains terms, acronyms, and definitions.

## 13 Mechanical, Packaging, and Orderable Information

The following pages include mechanical, packaging, and orderable information. This information is the most current data available for the designated devices. This data is subject to change without notice and revision of this document. For browser-based versions of this data sheet, refer to the left-hand navigation.

**PACKAGING INFORMATION**

Orderable Device	Status (1)	Package Type	Package Drawing	Pins	Package Qty	Eco Plan (2)	Lead/Ball Finish (6)	MSL Peak Temp (3)	Op Temp (°C)	Device Marking (4/5)	Samples
PCA9555DB	ACTIVE	SSOP	DB	24	60	Green (RoHS & no Sb/Br)	CU NIPDAU	Level-1-260C-UNLIM	-40 to 85	PD9555	<a href="#">Samples</a>
PCA9555DBQR	ACTIVE	SSOP	DBQ	24	2500	Green (RoHS & no Sb/Br)	CU NIPDAU	Level-2-260C-1 YEAR	-40 to 85	PCA9555	<a href="#">Samples</a>
PCA9555DBR	ACTIVE	SSOP	DB	24	2000	Green (RoHS & no Sb/Br)	CU NIPDAU	Level-1-260C-UNLIM	-40 to 85	PD9555	<a href="#">Samples</a>
PCA9555DGVR	ACTIVE	TVSOP	DGV	24	2000	Green (RoHS & no Sb/Br)	CU NIPDAU	Level-1-260C-UNLIM	-40 to 85	PD9555	<a href="#">Samples</a>
PCA9555DW	ACTIVE	SOIC	DW	24	25	Green (RoHS & no Sb/Br)	CU NIPDAU	Level-1-260C-UNLIM	-40 to 85	PCA9555	<a href="#">Samples</a>
PCA9555DWR	ACTIVE	SOIC	DW	24	2000	Green (RoHS & no Sb/Br)	CU NIPDAU	Level-1-260C-UNLIM	-40 to 85	PCA9555	<a href="#">Samples</a>
PCA9555DWRG4	ACTIVE	SOIC	DW	24	2000	Green (RoHS & no Sb/Br)	CU NIPDAU	Level-1-260C-UNLIM	-40 to 85	PCA9555	<a href="#">Samples</a>
PCA9555DWT	NRND	SOIC	DW	24		TBD	Call TI	Call TI	-40 to 85		
PCA9555N	NRND	PDIP	N	24		TBD	Call TI	Call TI	-40 to 85		
PCA9555PW	ACTIVE	TSSOP	PW	24	60	Green (RoHS & no Sb/Br)	CU NIPDAU	Level-1-260C-UNLIM	-40 to 85	PD9555	<a href="#">Samples</a>
PCA9555PWE4	ACTIVE	TSSOP	PW	24	60	Green (RoHS & no Sb/Br)	CU NIPDAU	Level-1-260C-UNLIM	-40 to 85	PD9555	<a href="#">Samples</a>
PCA9555PWR	NRND	TSSOP	PW	24	2000	Green (RoHS & no Sb/Br)	CU NIPDAU	Level-1-260C-UNLIM	-40 to 85	PD9555	
PCA9555PWRG4	NRND	TSSOP	PW	24	2000	Green (RoHS & no Sb/Br)	CU NIPDAU	Level-1-260C-UNLIM	-40 to 85	PD9555	
PCA9555PWT	NRND	TSSOP	PW	24		TBD	Call TI	Call TI	-40 to 85		
PCA9555RGER	ACTIVE	VQFN	RGE	24	3000	Green (RoHS & no Sb/Br)	CU NIPDAU	Level-2-260C-1 YEAR	-40 to 85	PD9555	<a href="#">Samples</a>
PCA9555RGERG4	ACTIVE	VQFN	RGE	24	3000	Green (RoHS & no Sb/Br)	CU NIPDAU	Level-2-260C-1 YEAR	-40 to 85	PD9555	<a href="#">Samples</a>
PCA9555RHLR	NRND	VQFN	RHL	24		TBD	Call TI	Call TI	-40 to 85		

(1) The marketing status values are defined as follows:

**ACTIVE:** Product device recommended for new designs.

**LIFEBUY:** TI has announced that the device will be discontinued, and a lifetime-buy period is in effect.

---

**NRND:** Not recommended for new designs. Device is in production to support existing customers, but TI does not recommend using this part in a new design.

**PREVIEW:** Device has been announced but is not in production. Samples may or may not be available.

**OBSOLETE:** TI has discontinued the production of the device.

<sup>(2)</sup> **RoHS:** TI defines "RoHS" to mean semiconductor products that are compliant with the current EU RoHS requirements for all 10 RoHS substances, including the requirement that RoHS substance do not exceed 0.1% by weight in homogeneous materials. Where designed to be soldered at high temperatures, "RoHS" products are suitable for use in specified lead-free processes. TI may reference these types of products as "Pb-Free".

**RoHS Exempt:** TI defines "RoHS Exempt" to mean products that contain lead but are compliant with EU RoHS pursuant to a specific EU RoHS exemption.

**Green:** TI defines "Green" to mean the content of Chlorine (Cl) and Bromine (Br) based flame retardants meet JS709B low halogen requirements of  $\leq 1000$ ppm threshold. Antimony trioxide based flame retardants must also meet the  $\leq 1000$ ppm threshold requirement.

<sup>(3)</sup> MSL, Peak Temp. - The Moisture Sensitivity Level rating according to the JEDEC industry standard classifications, and peak solder temperature.

<sup>(4)</sup> There may be additional marking, which relates to the logo, the lot trace code information, or the environmental category on the device.

<sup>(5)</sup> Multiple Device Markings will be inside parentheses. Only one Device Marking contained in parentheses and separated by a "~" will appear on a device. If a line is indented then it is a continuation of the previous line and the two combined represent the entire Device Marking for that device.

<sup>(6)</sup> Lead/Ball Finish - Orderable Devices may have multiple material finish options. Finish options are separated by a vertical ruled line. Lead/Ball Finish values may wrap to two lines if the finish value exceeds the maximum column width.

**Important Information and Disclaimer:** The information provided on this page represents TI's knowledge and belief as of the date that it is provided. TI bases its knowledge and belief on information provided by third parties, and makes no representation or warranty as to the accuracy of such information. Efforts are underway to better integrate information from third parties. TI has taken and continues to take reasonable steps to provide representative and accurate information but may not have conducted destructive testing or chemical analysis on incoming materials and chemicals. TI and TI suppliers consider certain information to be proprietary, and thus CAS numbers and other limited information may not be available for release.

In no event shall TI's liability arising out of such information exceed the total purchase price of the TI part(s) at issue in this document sold by TI to Customer on an annual basis.

**TAPE AND REEL INFORMATION**

**QUADRANT ASSIGNMENTS FOR PIN 1 ORIENTATION IN TAPE**


\*All dimensions are nominal

Device	Package Type	Package Drawing	Pins	SPQ	Reel Diameter (mm)	Reel Width W1 (mm)	A0 (mm)	B0 (mm)	K0 (mm)	P1 (mm)	W (mm)	Pin1 Quadrant
PCA9555DBQR	SSOP	DBQ	24	2500	330.0	16.4	6.5	9.0	2.1	8.0	16.0	Q1
PCA9555DBR	SSOP	DB	24	2000	330.0	16.4	8.2	8.8	2.5	12.0	16.0	Q1
PCA9555DGVR	TVSOP	DGV	24	2000	330.0	12.4	6.9	5.6	1.6	8.0	12.0	Q1
PCA9555DWR	SOIC	DW	24	2000	330.0	24.4	10.75	15.7	2.7	12.0	24.0	Q1
PCA9555PWR	TSSOP	PW	24	2000	330.0	16.4	6.95	8.3	1.6	8.0	16.0	Q1
PCA9555RGER	VQFN	RGE	24	3000	330.0	12.4	4.25	4.25	1.15	8.0	12.0	Q2

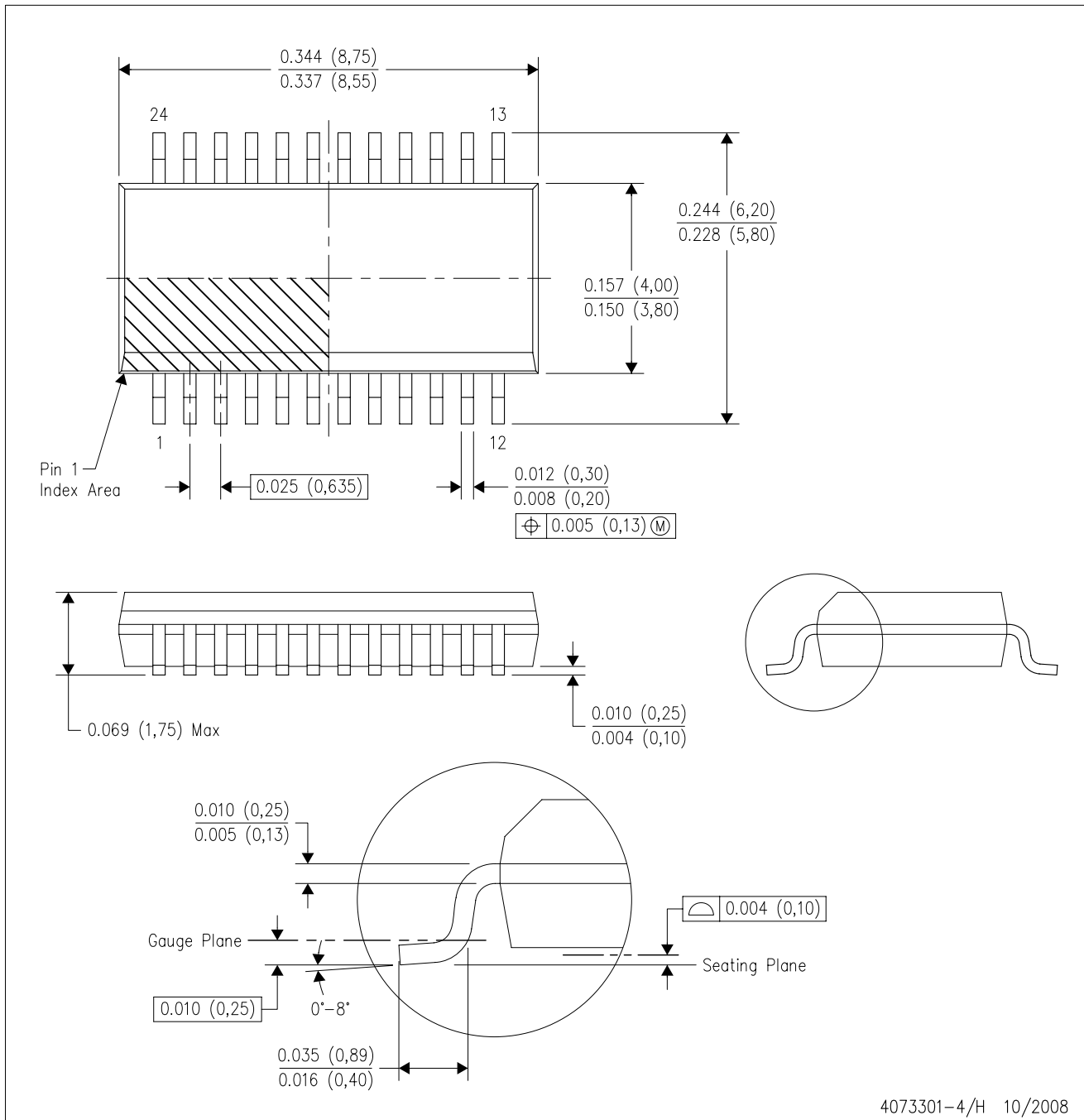
**TAPE AND REEL BOX DIMENSIONS**


\*All dimensions are nominal

Device	Package Type	Package Drawing	Pins	SPQ	Length (mm)	Width (mm)	Height (mm)
PCA9555DBQR	SSOP	DBQ	24	2500	367.0	367.0	38.0
PCA9555DBR	SSOP	DB	24	2000	367.0	367.0	38.0
PCA9555DGVR	TVSOP	DGV	24	2000	367.0	367.0	35.0
PCA9555DWR	SOIC	DW	24	2000	350.0	350.0	43.0
PCA9555PWR	TSSOP	PW	24	2000	367.0	367.0	38.0
PCA9555RGER	VQFN	RGE	24	3000	367.0	367.0	35.0

DBQ (R-PDSO-G24)

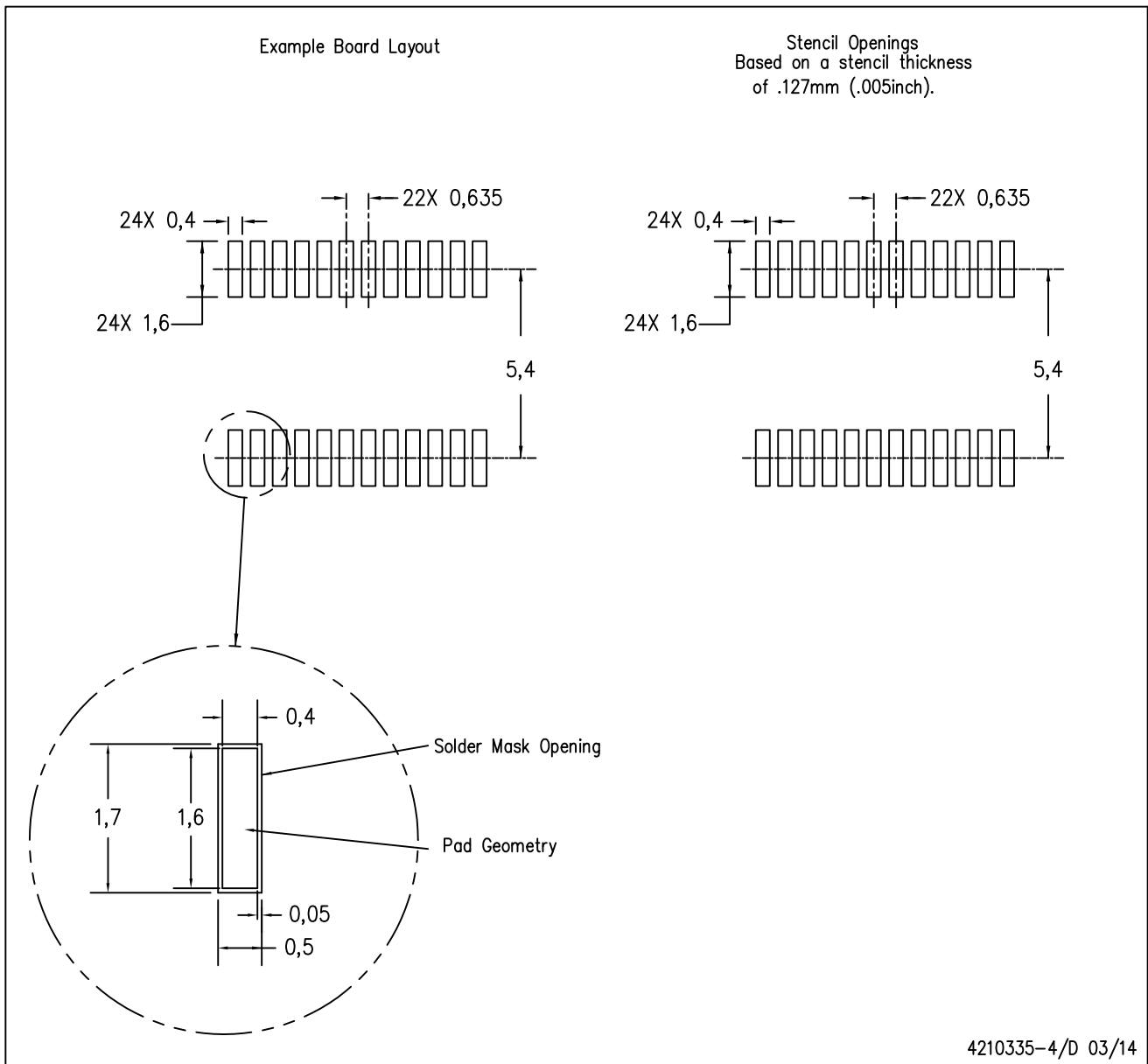
PLASTIC SMALL-OUTLINE PACKAGE



- NOTES:
- All linear dimensions are in inches (millimeters).
  - This drawing is subject to change without notice.
  - Body dimensions do not include mold flash or protrusion not to exceed 0.006 (0,15) per side.
  - Falls within JEDEC MO-137 variation AE.

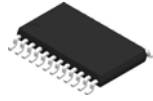
DBQ (R-PDSO-G24)

PLASTIC SMALL OUTLINE PACKAGE



- NOTES:
- A. All linear dimensions are in millimeters.
  - B. This drawing is subject to change without notice.
  - C. Publication IPC-7351 is recommended for alternate designs.
  - D. Laser cutting apertures with trapezoidal walls and also rounding corners will offer better paste release. Customers should contact their board assembly site for stencil design recommendations. Example stencil design based on a 50% volumetric metal load solder paste. Refer to IPC-7525 for other stencil recommendations.

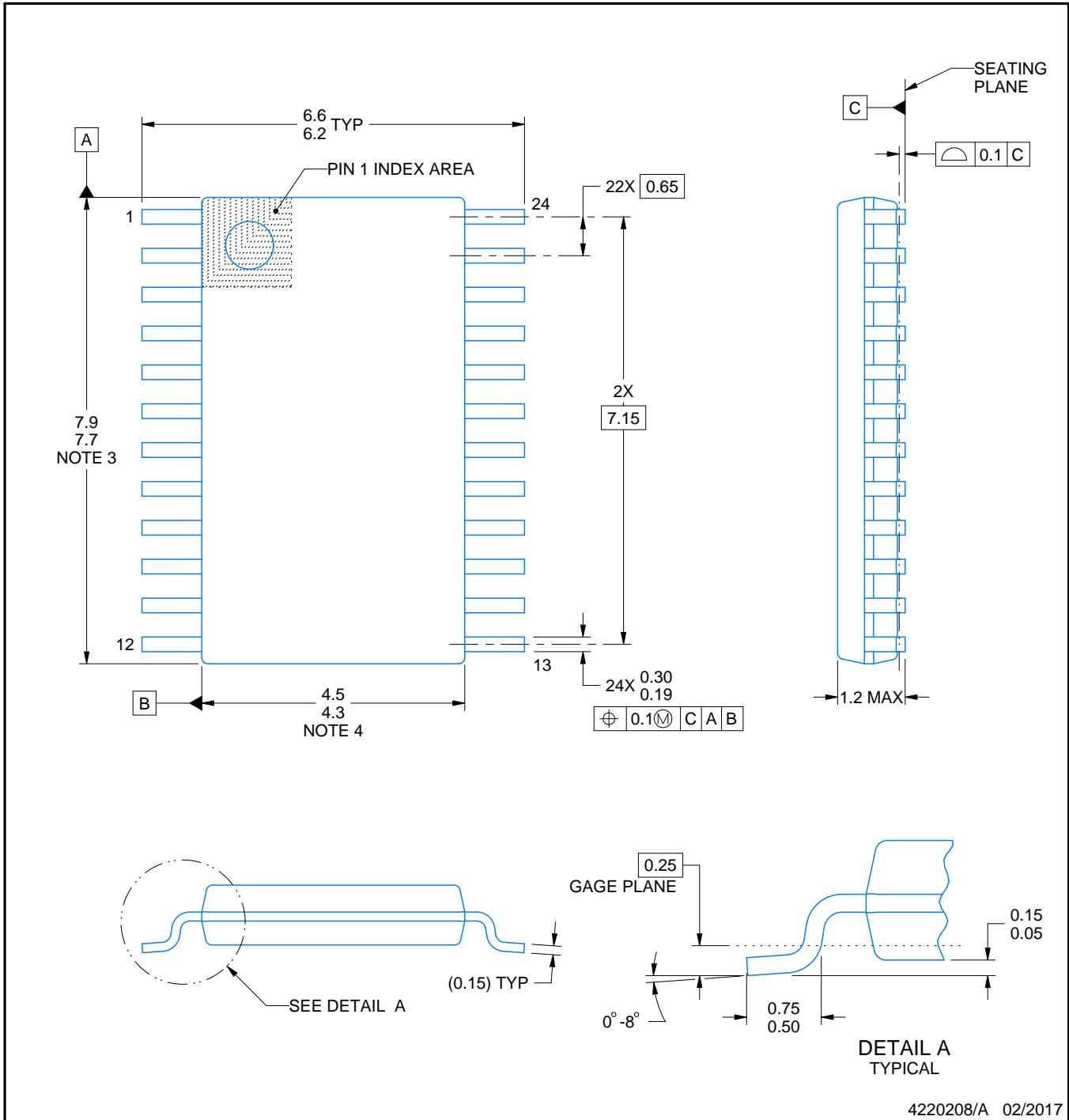
PW0024A



# PACKAGE OUTLINE

## TSSOP - 1.2 mm max height

SMALL OUTLINE PACKAGE



4220208/A 02/2017

NOTES:

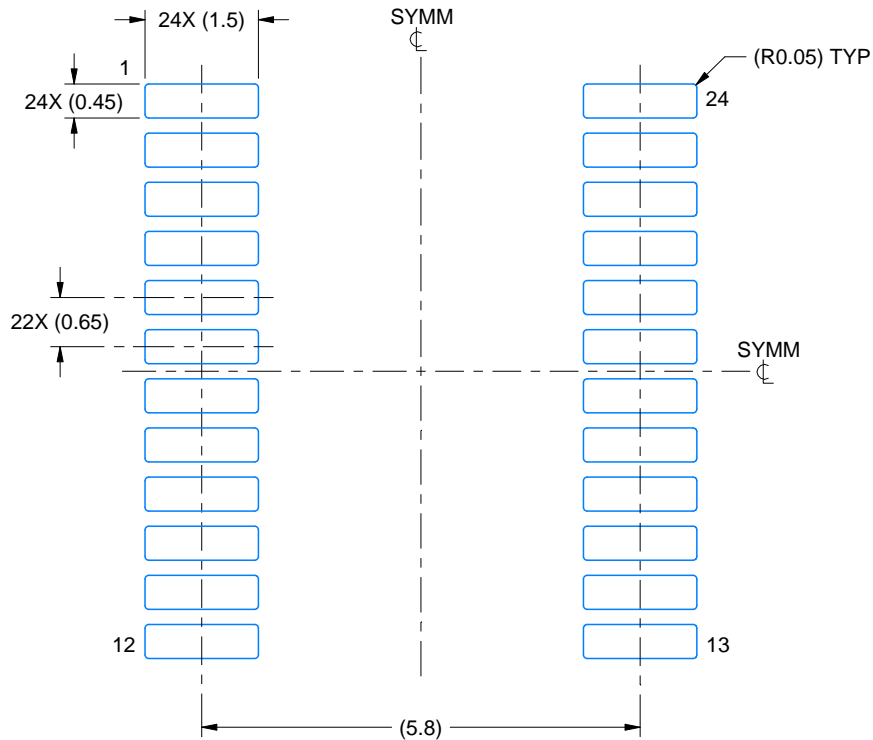
1. All linear dimensions are in millimeters. Any dimensions in parenthesis are for reference only. Dimensioning and tolerancing per ASME Y14.5M.
2. This drawing is subject to change without notice.
3. This dimension does not include mold flash, protrusions, or gate burrs. Mold flash, protrusions, or gate burrs shall not exceed 0.15 mm per side.
4. This dimension does not include interlead flash. Interlead flash shall not exceed 0.25 mm per side.
5. Reference JEDEC registration MO-153.

# EXAMPLE BOARD LAYOUT

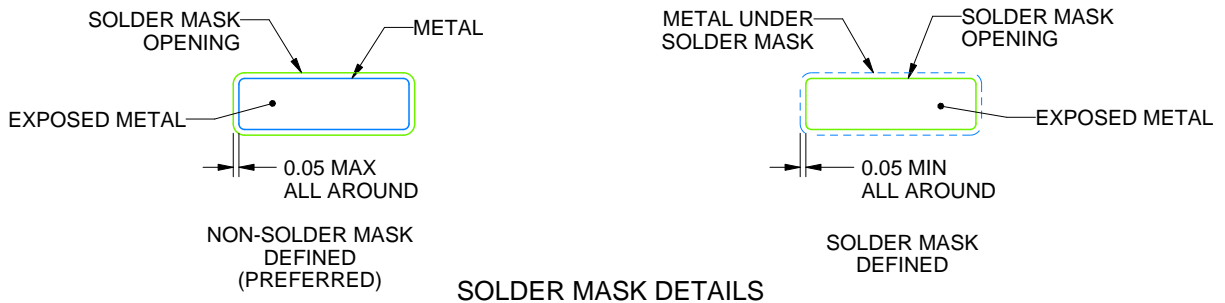
PW0024A

TSSOP - 1.2 mm max height

SMALL OUTLINE PACKAGE



LAND PATTERN EXAMPLE  
EXPOSED METAL SHOWN  
SCALE: 10X



SOLDER MASK DETAILS

4220208/A 02/2017

NOTES: (continued)

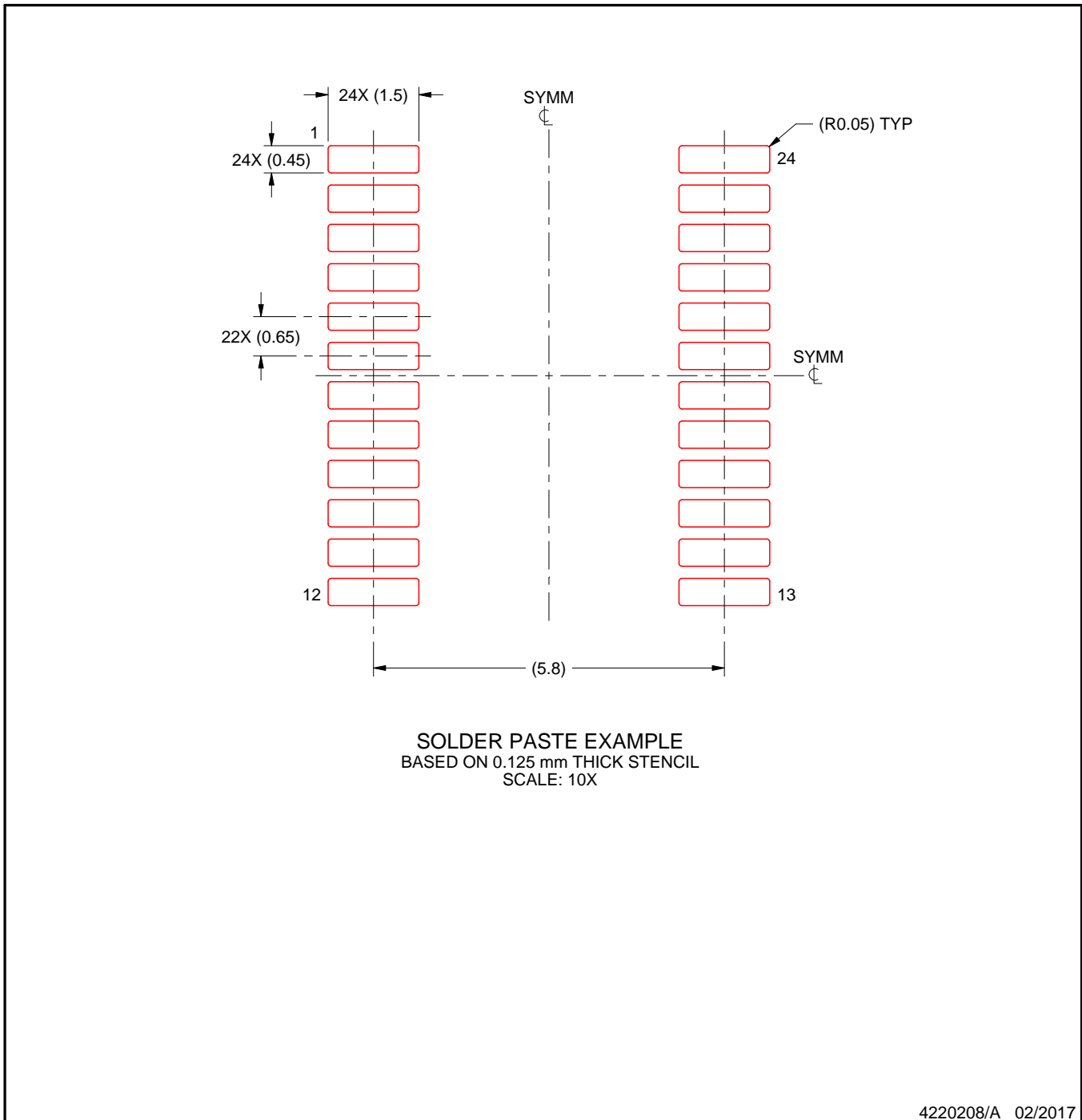
6. Publication IPC-7351 may have alternate designs.
7. Solder mask tolerances between and around signal pads can vary based on board fabrication site.

# EXAMPLE STENCIL DESIGN

PW0024A

TSSOP - 1.2 mm max height

SMALL OUTLINE PACKAGE

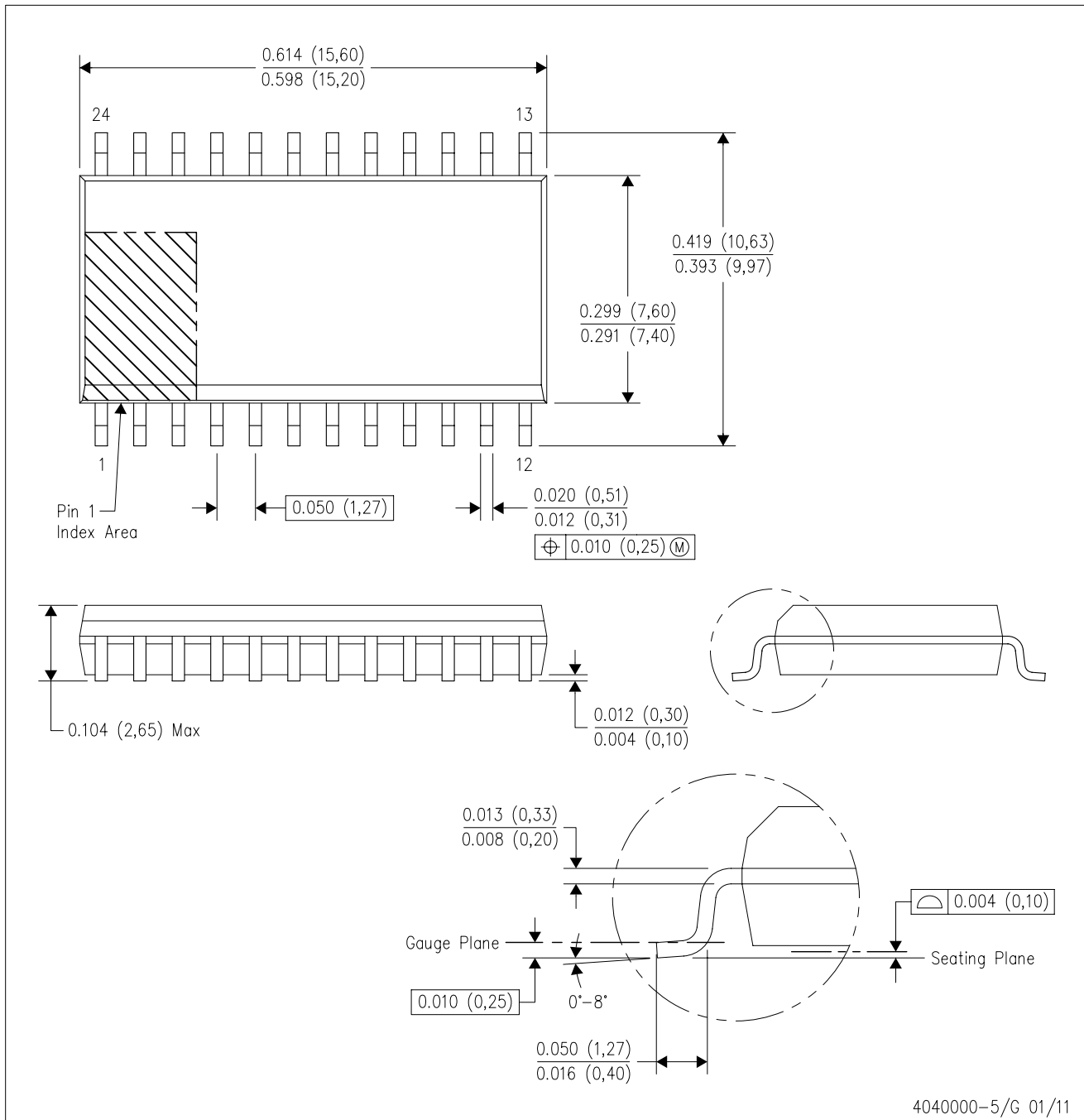


NOTES: (continued)

8. Laser cutting apertures with trapezoidal walls and rounded corners may offer better paste release. IPC-7525 may have alternate design recommendations.
9. Board assembly site may have different recommendations for stencil design.

DW (R-PDSO-G24)

PLASTIC SMALL OUTLINE



- NOTES:
- A. All linear dimensions are in inches (millimeters). Dimensioning and tolerancing per ASME Y14.5M-1994.
  - B. This drawing is subject to change without notice.
  - C. Body dimensions do not include mold flash or protrusion not to exceed 0.006 (0,15).
  - D. Falls within JEDEC MS-013 variation AD.

DB (R-PDSO-G\*\*)

PLASTIC SMALL-OUTLINE

28 PINS SHOWN

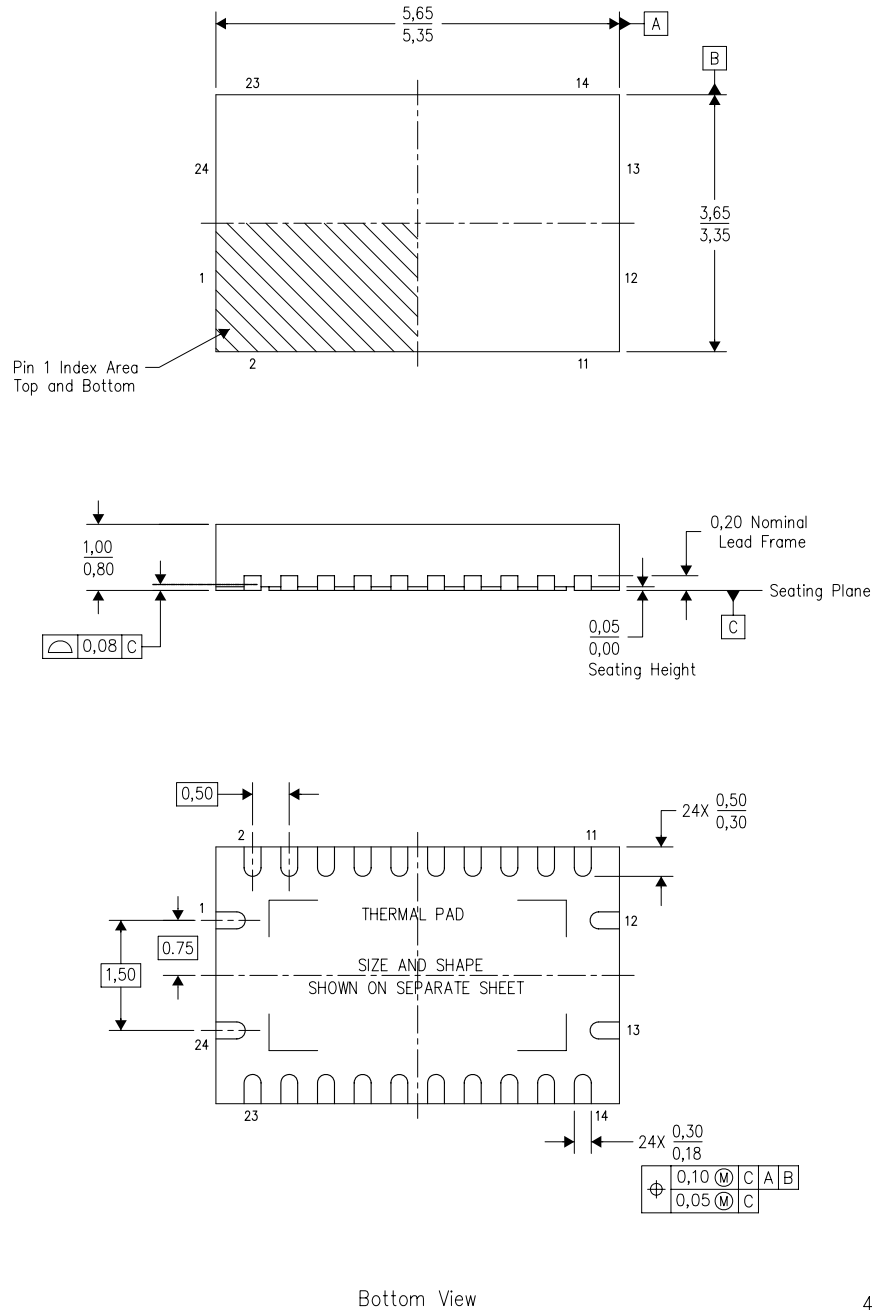


- NOTES: A. All linear dimensions are in millimeters.  
 B. This drawing is subject to change without notice.  
 C. Body dimensions do not include mold flash or protrusion not to exceed 0,15.  
 D. Falls within JEDEC MO-150

# MECHANICAL DATA

RHL (R-PVQFN-N24)

PLASTIC QUAD FLATPACK NO-LEAD



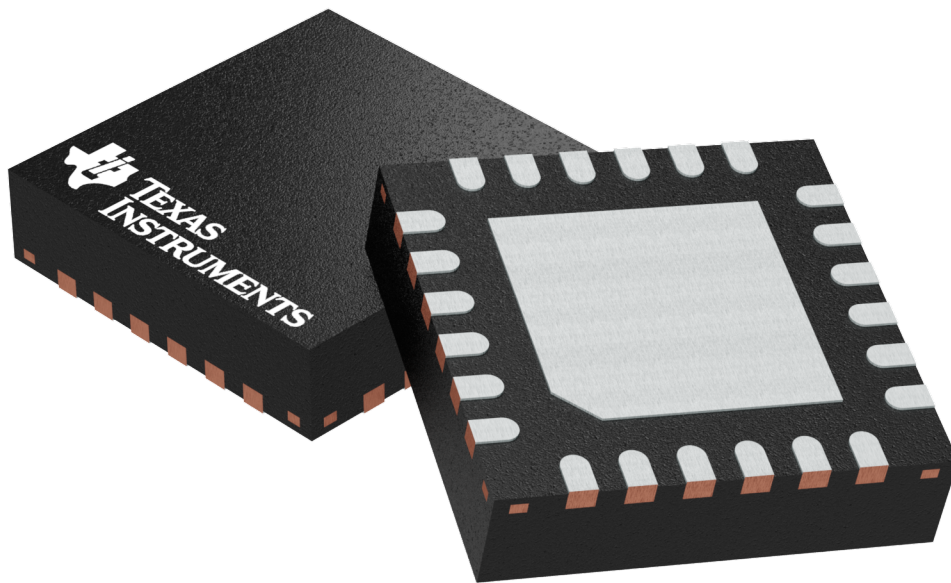
- NOTES:
- All linear dimensions are in millimeters. Dimensioning and tolerancing per ASME Y14.5M-1994.
  - This drawing is subject to change without notice.
  - QFN (Quad Flatpack No-Lead) package configuration.
  - The package thermal pad must be soldered to the board for thermal and mechanical performance.
  - See the additional figure in the Product Data Sheet for details regarding the exposed thermal pad features and dimensions.
  - JEDEC MO-241 package registration pending.

**RGE 24**

**GENERIC PACKAGE VIEW**

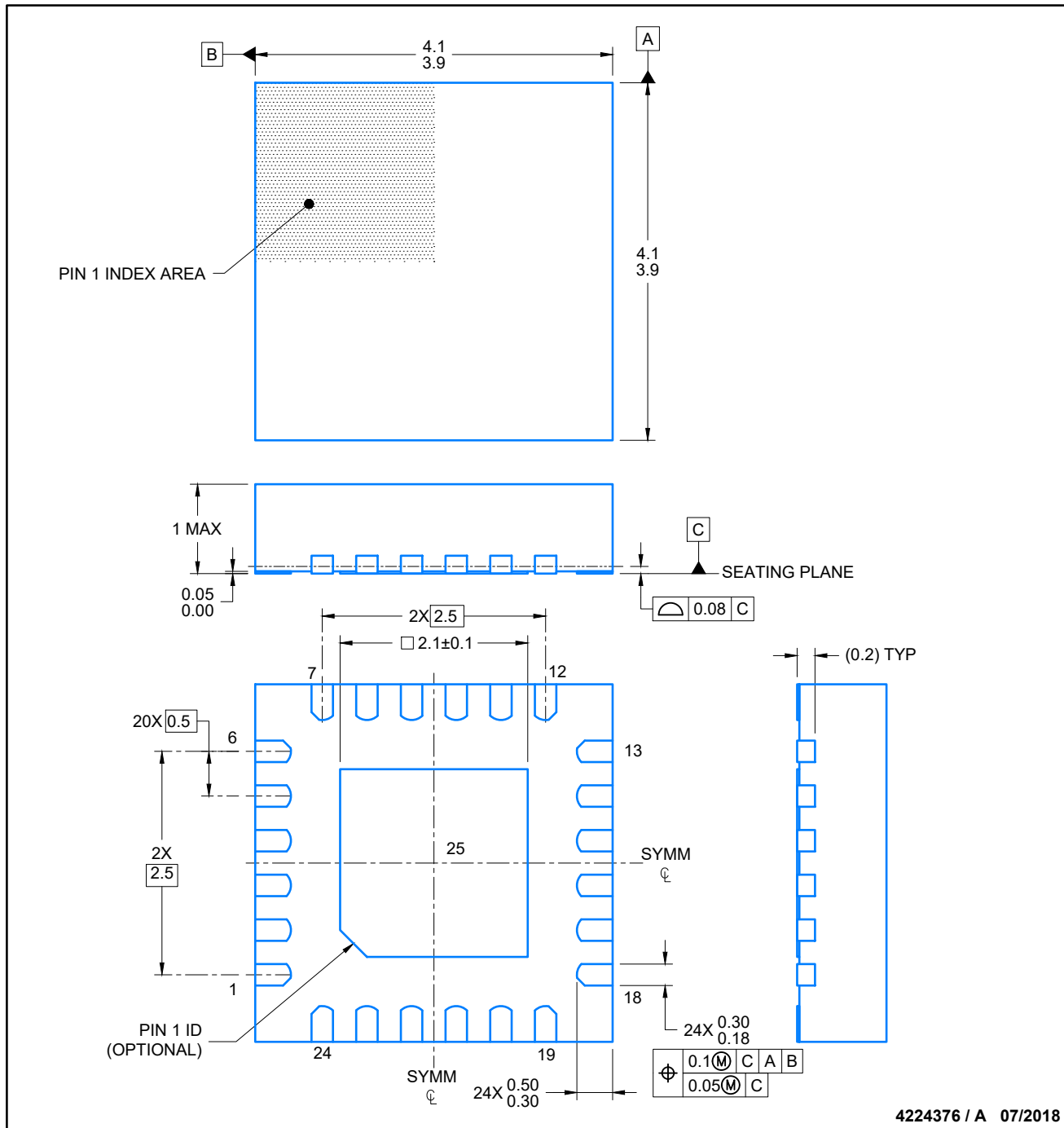
**VQFN - 1 mm max height**

PLASTIC QUAD FLATPACK - NO LEAD



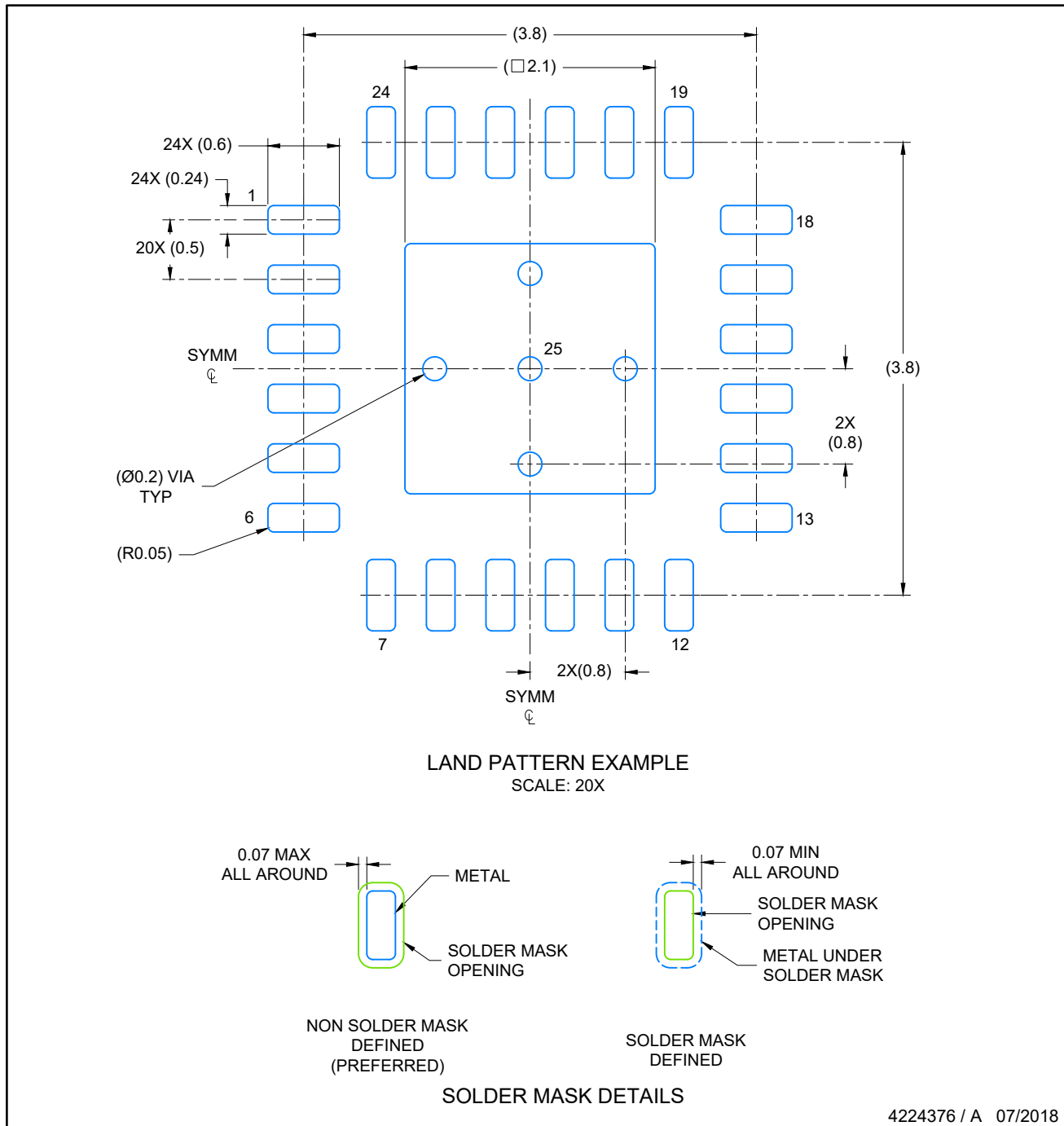
Images above are just a representation of the package family, actual package may vary.  
Refer to the product data sheet for package details.

4204104/H



NOTES:

1. All linear dimensions are in millimeters. Any dimensions in parenthesis are for reference only. Dimensioning and tolerancing per ASME Y14.5M.
2. This drawing is subject to change without notice.
3. The package thermal pad must be soldered to the printed circuit board for thermal and mechanical performance.



NOTES: (continued)

4. This package is designed to be soldered to a thermal pad on the board. For more information, see Texas Instruments literature number SLUA271 ([www.ti.com/lit/slua271](http://www.ti.com/lit/slua271)).
5. Solder mask tolerances between and around signal pads can vary based on board fabrication site.



## IMPORTANT NOTICE AND DISCLAIMER

TI PROVIDES TECHNICAL AND RELIABILITY DATA (INCLUDING DATASHEETS), DESIGN RESOURCES (INCLUDING REFERENCE DESIGNS), APPLICATION OR OTHER DESIGN ADVICE, WEB TOOLS, SAFETY INFORMATION, AND OTHER RESOURCES "AS IS" AND WITH ALL FAULTS, AND DISCLAIMS ALL WARRANTIES, EXPRESS AND IMPLIED, INCLUDING WITHOUT LIMITATION ANY IMPLIED WARRANTIES OF MERCHANTABILITY, FITNESS FOR A PARTICULAR PURPOSE OR NON-INFRINGEMENT OF THIRD PARTY INTELLECTUAL PROPERTY RIGHTS.

These resources are intended for skilled developers designing with TI products. You are solely responsible for (1) selecting the appropriate TI products for your application, (2) designing, validating and testing your application, and (3) ensuring your application meets applicable standards, and any other safety, security, or other requirements. These resources are subject to change without notice. TI grants you permission to use these resources only for development of an application that uses the TI products described in the resource. Other reproduction and display of these resources is prohibited. No license is granted to any other TI intellectual property right or to any third party intellectual property right. TI disclaims responsibility for, and you will fully indemnify TI and its representatives against, any claims, damages, costs, losses, and liabilities arising out of your use of these resources.

TI's products are provided subject to TI's Terms of Sale ([www.ti.com/legal/termsofsale.html](http://www.ti.com/legal/termsofsale.html)) or other applicable terms available either on [ti.com](http://ti.com) or provided in conjunction with such TI products. TI's provision of these resources does not expand or otherwise alter TI's applicable warranties or warranty disclaimers for TI products.

Mailing Address: Texas Instruments, Post Office Box 655303, Dallas, Texas 75265  
Copyright © 2019, Texas Instruments Incorporated

## Looking for pricing, stock, or lifecycle information?

Click below to explore more details on WIN SOURCE:

 [View PCA9555RGER](#) on WIN SOURCE

 [Texas Instruments](#) Information

## Optimize Your Supply Chain with WIN SOURCE Solutions

-  Global Sourcing Solution
-  Obsolete Management
-  Cost Control Management
-  Shortage Management
-  Alternative Solution
-  Excess Inventory Management