



THE DATASHEET OF PCA9554DWR



PCA9554 Remote 8-Bit I²C AND SMBus I/O Expander With Interrupt Output and Configuration Registers

1 Features

- I²C to Parallel Port Expander
- Open-Drain Active-Low Interrupt Output
- Operating Power-Supply Voltage Range of 2.3 V to 5.5 V
- 5-V Tolerant I/Os
- 400-kHz Fast I²C Bus
- Three Hardware Address Pins Allow up to Eight Devices on the I²C/SMBus
- Input/Output Configuration Register
- Polarity Inversion Register
- Internal Power-On Reset
- Power-Up With All Channels Configured as Inputs
- No Glitch On Power Up
- Latched Outputs With High-Current Drive Maximum Capability for Directly Driving LEDs
- Latch-Up Performance Exceeds 100 mA Per JESD 78, Class II
- ESD Protection Exceeds JESD 22
 - 2000-V Human-Body Model (A114-A)
 - 200-V Machine Model (A115-A)
 - 1000-V Charged-Device Model (C101)

2 Description

This 8-bit I/O expander for the two-line bidirectional bus (I²C) is designed for 2.3-V to 5.5-V V_{CC} operation. It provides general-purpose remote I/O expansion for most microcontroller families via the I²C interface [serial clock (SCL), serial data (SDA)].

The PCA9554 consists of one 8-bit Configuration (input or output selection), Input, Output, and Polarity Inversion (active high or active low) registers. At power on, the I/Os are configured as inputs with a weak pullup to V_{CC}. However, the system master can enable the I/Os as either inputs or outputs by writing to the I/O configuration bits. The data for each input or output is kept in the corresponding Input or Output register. The polarity of the Input Port register can be inverted with the Polarity Inversion register. All registers can be read by the system master.

The system master can reset the PCA9554 in the event of a timeout or other improper operation by utilizing the power-on reset feature, which puts the registers in their default state and initializes the I²C/SMBus state machine.

The PCA9554 open-drain interrupt ($\overline{\text{INT}}$) output is activated when any input state differs from its corresponding Input Port register state and is used to indicate to the system master that an input state has changed.

Device Information⁽¹⁾

PART NUMBER	PACKAGE	BODY SIZE (NOM)
PCA9554	SSOP (16)	6.20 mm x 5.30 mm
	VQFN (16)	4.00 mm x 4.00 mm
	QFN (16)	3.00 mm x 3.00 mm

(1) For all available packages, see the orderable addendum at the end of the datasheet.

DB, DBQ, DGV, DW, OR PW PACKAGE (TOP VIEW)

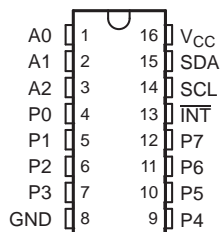

RGV PACKAGE (TOP VIEW)

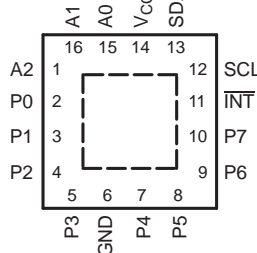

RGT PACKAGE (TOP VIEW)

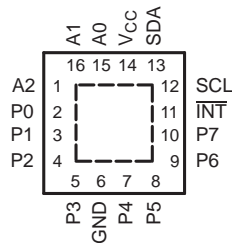

Table of Contents

1 Features 1 2 Description 1 3 Revision History 2 4 Description (Continued) 3 5 Pin Configuration and Functions 3 6 Specifications 4 6.1 Absolute Maximum Ratings 4 6.2 Handling Ratings..... 4 6.3 Recommended Operating Conditions 4 6.4 Electrical Characteristics..... 5 6.5 I ² C Interface Timing Requirements..... 6 6.6 Switching Characteristics 6 6.7 Typical Characteristics 7 7 Parameter Measurement Information 10	8 Detailed Description 13 8.1 Functional Block Diagram 13 8.2 Device Functional Modes..... 14 8.3 Programming..... 15 9 Application And Implementation 21 9.1 Typical Application 21 10 Power Supply Recommendations 23 10.1 Power-On Reset Errata..... 23 11 Device and Documentation Support 24 11.1 Trademarks 24 11.2 Electrostatic Discharge Caution..... 24 11.3 Glossary 24 12 Mechanical, Packaging, and Orderable Information 24
---	--

3 Revision History

Changes from Revision B (August 2008) to Revision C	Page
• Added Interrupt Errata section.....	15
• Added Power-On Reset Errata section.	23

4 Description (Continued)

$\overline{\text{INT}}$ can be connected to the interrupt input of a microcontroller. By sending an interrupt signal on this line, the remote I/O can inform the microcontroller if there is incoming data on its ports without having to communicate via the I²C bus. Thus, the PCA9554 can remain a simple slave device.

The device's outputs (latched) have high-current drive capability for directly driving LEDs and low current consumption.

Three hardware pins (A0, A1, and A2) are used to program and vary the fixed I²C address and allow up to eight devices to share the same I²C bus or SMBus.

The PCA9554 is pin-to-pin and I²C address compatible with the PCF8574. However, software changes are required, due to the enhancements in the PCA9554 over the PCF8574.

The PCA9554 and PCA9554A are identical except for their fixed I²C address. This allows for up to 16 of these devices (eight of each) on the same I²C/SMBus.

5 Pin Configuration and Functions

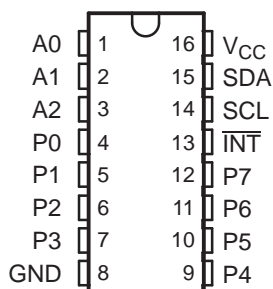
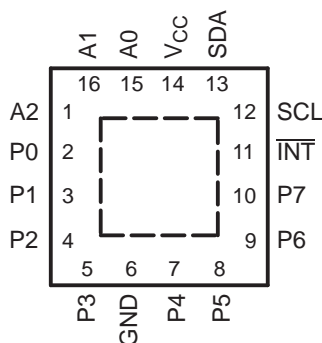
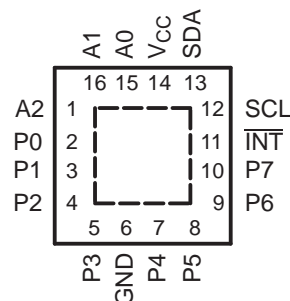
**DB, DBQ, DGV, DW, OR PW PACKAGE
(TOP VIEW)**

**RGV PACKAGE
(TOP VIEW)**

**RGT PACKAGE
(TOP VIEW)**

Pin Functions

NAME	PIN		DESCRIPTION
	QSOP (DBQ), SOIC (DW), SSOP (DB), TSSOP (PW), AND TVSOP (DGV)	QFN (RGT) AND QFN (RGV)	
A0	1	15	Address input. Connect directly to V _{CC} or ground.
A1	2	16	Address input. Connect directly to V _{CC} or ground.
A2	3	1	Address input. Connect directly to V _{CC} or ground.
P0	4	2	P-port input/output. Push-pull design structure.
P1	5	3	P-port input/output. Push-pull design structure.
P2	6	4	P-port input/output. Push-pull design structure.
P3	7	5	P-port input/output. Push-pull design structure.
GND	8	6	Ground
P4	9	7	P-port input/output. Push-pull design structure.
P5	10	8	P-port input/output. Push-pull design structure.
P6	11	9	P-port input/output. Push-pull design structure.
P7	12	10	P-port input/output. Push-pull design structure.
$\overline{\text{INT}}$	13	11	Interrupt output. Connect to V _{CC} through a pullup resistor.
SCL	14	12	Serial clock bus. Connect to V _{CC} through a pullup resistor.
SDA	15	13	Serial data bus. Connect to V _{CC} through a pullup resistor.
V _{CC}	16	14	Supply voltage

6 Specifications

6.1 Absolute Maximum Ratings⁽¹⁾

over operating free-air temperature range (unless otherwise noted)

		MIN	MAX	UNIT
V _{CC}	Supply voltage range	-0.5	6	V
V _I	Input voltage range ⁽²⁾	-0.5	6	V
V _O	Output voltage range ⁽²⁾	-0.5	6	V
I _{IK}	Input clamp current	V _I < 0		-20 mA
I _{OK}	Output clamp current	V _O < 0		-20 mA
I _{I_{OK}}	Input/output clamp current	V _O < 0 or V _O > V _{CC}		±20 mA
I _{OL}	Continuous output low current	V _O = 0 to V _{CC}		50 mA
I _{OH}	Continuous output high current	V _O = 0 to V _{CC}		-50 mA
I _{CC}	Continuous current through GND			-250 mA
	Continuous current through V _{CC}			160 mA
θ _{JA}	Package thermal impedance ⁽³⁾	DB package		82
		DBQ package		90
		DGV package		120
		DW package		57
		N package		67
		PW package		108
		RGT package		TBD
RGV package		TBD		

- (1) Stresses beyond those listed under "absolute maximum ratings" may cause permanent damage to the device. These are stress ratings only, and functional operation of the device at these or any other conditions beyond those indicated under "recommended operating conditions" is not implied. Exposure to absolute-maximum-rated conditions for extended periods may affect device reliability.
- (2) The input negative-voltage and output voltage ratings may be exceeded if the input and output current ratings are observed.
- (3) The package thermal impedance is calculated in accordance with JESD 51-7.

6.2 Handling Ratings

		MIN	MAX	UNIT
T _{stg}	Storage temperature range	-65	150	°C
V _(ESD)	Electrostatic discharge	Human body model (HBM), per ANSI/ESDA/JEDEC JS-001, all pins ⁽¹⁾		0 2000
		Charged device model (CDM), per JEDEC specification JESD22-C101, all pins ⁽²⁾		0 1000

- (1) JEDEC document JEP155 states that 500-V HBM allows safe manufacturing with a standard ESD control process.
- (2) JEDEC document JEP157 states that 250-V CDM allows safe manufacturing with a standard ESD control process.

6.3 Recommended Operating Conditions

		MIN	MAX	UNIT
V _{CC}	Supply voltage	2.3	5.5	V
V _{IH}	High-level input voltage	SCL, SDA		0.7 × V _{CC} 5.5
		A2–A0, P7–P0		2 5.5
V _{IL}	Low-level input voltage	SCL, SDA		-0.5 0.3 × V _{CC}
		A2–A0, P7–P0		-0.5 0.8
I _{OH}	High-level output current	P7–P0		-10 mA
I _{OL}	Low-level output current	P7–P0		25 mA
T _A	Operating free-air temperature	-40	85	°C

6.4 Electrical Characteristics

over operating free-air temperature range (unless otherwise noted)

PARAMETER		TEST CONDITIONS	V _{CC}	MIN	TYP ⁽¹⁾	MAX	UNIT	
V _{IK}	Input diode clamp voltage	I _I = -18 mA	2.3 V to 5.5 V	-1.2			V	
V _{POR}	Power-on reset voltage	V _I = V _{CC} or GND, I _O = 0	V _{POR}		1.5	1.65	V	
V _{OH}	P-port high-level output voltage ⁽²⁾	I _{OH} = -8 mA	2.3 V	1.8			V	
			3 V	2.6				
			4.5 V	3.1				
			4.75 V	4.1				
		I _{OH} = -10 mA	2.3 V	1.7				
			3 V	2.5				
			4.5 V	3				
			4.75 V	4				
I _{OL}	SDA	V _{OL} = 0.4 V	2.3 V to 5.5 V	3	8		mA	
	P port ⁽³⁾	V _{OL} = 0.5 V	2.3 V	8	10			
			3 V	8	14			
			4.5 V	8	17			
			4.75 V	8	35			
	P port ⁽³⁾	V _{OL} = 0.7 V	2.3 V	10	13			
			3 V	10	19			
			4.5 V	10	24			
			4.75 V	10	45			
	INT	V _{OL} = 0.4 V	2.3 V to 5.5 V	3	10			
I _I	SCL, SDA	V _I = V _{CC} or GND	2.3 V to 5.5 V			±1	μA	
	A2–A0					±1		
I _{IH}	P port	V _I = V _{CC}	2.3 V to 5.5 V			1	μA	
I _{IL}	P port	V _I = GND	2.3 V to 5.5 V			-100	μA	
I _{CC}	Operating mode	V _I = V _{CC} , I _O = 0, I/O = inputs, f _{scl} = 400 kHz, No load	5.5 V		104	175	μA	
			3.6 V		50	90		
			2.7 V		20	65		
			5.5 V		60	150		
			3.6 V		15	40		
			2.7 V		8	20		
	Standby mode	V _I = GND, I _O = 0, I/O = inputs, f _{scl} = 0 kHz, No load	5.5 V		450	700		
			3.6 V		300	600		
			2.7 V		225	500		
			5.5 V		0.25	1		
Standby mode	V _I = V _{CC} , I _O = 0, I/O = inputs, f _{scl} = 0 kHz, No load	3.6 V		0.2	0.9			
		2.7 V		0.1	0.8			
		2.7 V		0.1	0.8			
ΔI _{CC}	Additional current in standby mode	One input at V _{CC} - 0.6 V, Other inputs at V _{CC} or GND	2.3 V to 5.5 V			1.5	mA	
		Every LED I/O at V _I = 4.3 V, f _{scl} = 0 kHz	5.5 V			1		
C _i	SCL	V _I = V _{CC} or GND	2.3 V to 5.5 V		4	5	pF	
C _{io}	SDA	V _{IO} = V _{CC} or GND	2.3 V to 5.5 V		5.5	6.5	pF	
	P port				8	9.5		

(1) All typical values are at nominal supply voltage (2.5-V, 3.3-V, or 5-V V_{CC}) and T_A = 25°C.

(2) The total current sourced by all I/Os must be limited to 85 mA.

(3) Each I/O must be externally limited to a maximum of 25 mA, and the P port (P0 to P7) must be limited to a maximum current of 200 mA.

6.5 I²C Interface Timing Requirements

 over operating free-air temperature range (unless otherwise noted) (see [Figure 14](#))

		STANDARD MODE I ² C BUS		FAST MODE I ² C BUS		UNIT	
		MIN	MAX	MIN	MAX		
f_{scl}	I ² C clock frequency	0	100	0	400	kHz	
t_{sch}	I ² C clock high time	4		0.6		μs	
t_{scl}	I ² C clock low time	4.7		1.3		μs	
t_{sp}	I ² C spike time		50		50	ns	
t_{sds}	I ² C serial-data setup time	250		100		ns	
t_{sdh}	I ² C serial-data hold time	0		0		ns	
t_{icr}	I ² C input rise time		1000	$20 + 0.1C_b$ ⁽¹⁾	300	ns	
t_{icf}	I ² C input fall time		300	$20 + 0.1C_b$ ⁽¹⁾	300	ns	
t_{ocf}	I ² C output fall time	10-pF to 400-pF bus	300	$20 + 0.1C_b$ ⁽¹⁾	300	ns	
t_{buf}	I ² C bus free time between stop and start	4.7		1.3		μs	
t_{sts}	I ² C start or repeated start condition setup	4.7		0.6		μs	
t_{sth}	I ² C start or repeated start condition hold	4		0.6		μs	
t_{sps}	I ² C stop condition setup	4		0.6		μs	
$t_{vd(data)}$	Valid data time	SCL low to SDA output valid	300	50		ns	
$t_{vd(ack)}$	Valid data time of ACK condition	ACK signal from SCL low to SDA (out) low	0.3	3.45	0.1	0.9	μs
C_b	I ² C bus capacitive load		400		400	ns	

 (1) C_b = Total capacitive load of one bus in pF

6.6 Switching Characteristics

 over operating free-air temperature range (unless otherwise noted) (see [Figure 15](#) and [Figure 16](#))

PARAMETER		FROM (INPUT)	TO (OUTPUT)	STANDARD MODE I ² C BUS		FAST MODE I ² C BUS		UNIT
				MIN	MAX	MIN	MAX	
t_{iv}	Interrupt valid time	P port	\overline{INT}		4		4	μs
t_{ir}	Interrupt reset delay time	SCL	\overline{INT}		4		4	μs
t_{pv}	Output data valid	SCL	P7–P0		200		200	ns
t_{ps}	Input data setup time	P port	SCL	100		100		ns
t_{ph}	Input data hold time	P port	SCL	1		1		μs

6.7 Typical Characteristics

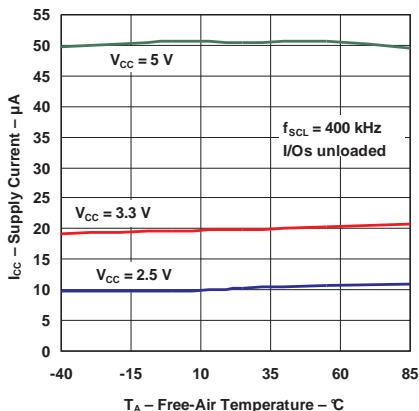

Figure 1. Supply Current vs Temperature

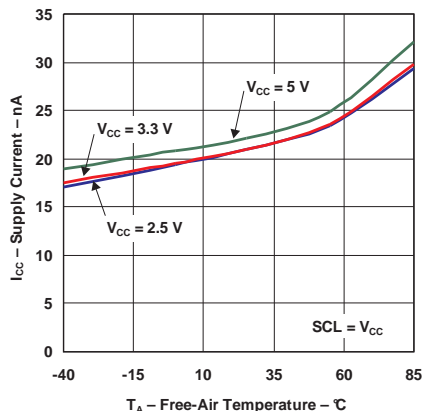

Figure 2. Quiescent Supply Current vs Temperature

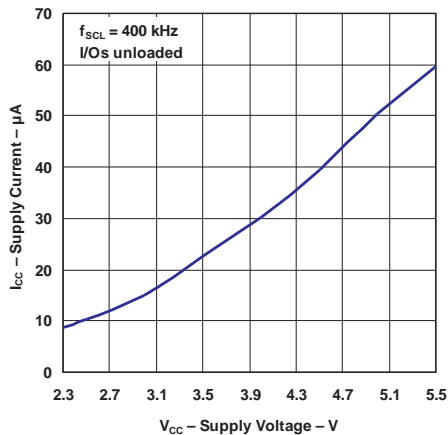

Figure 3. Supply Current vs Supply Voltage

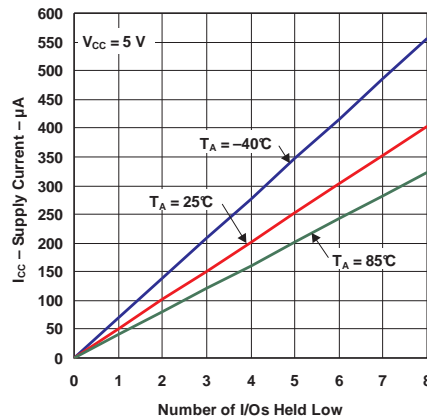

Figure 4. Supply Current vs Number Of I/Os Held Low

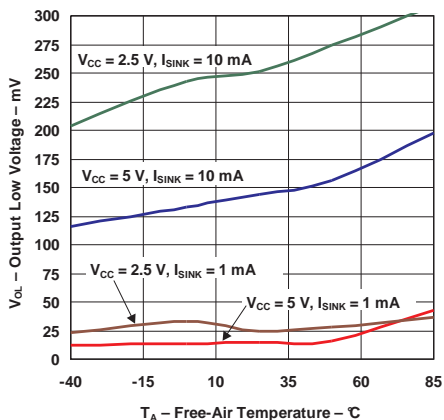

Figure 5. I/O Output Low Voltage vs Temperature

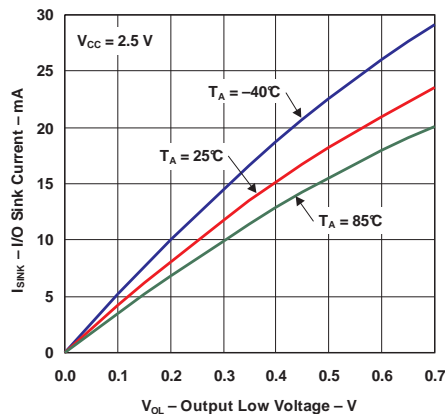

Figure 6. I/O Sink Current vs Output Low Voltage

Typical Characteristics (continued)

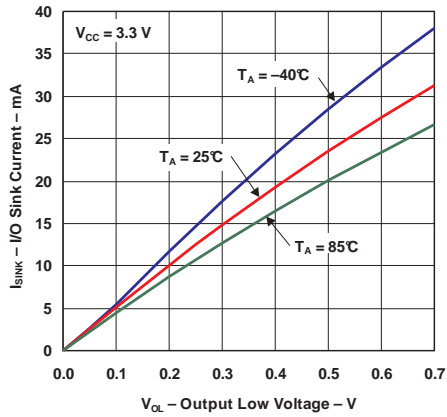

Figure 7. I/O Sink Current vs Output Low Voltage

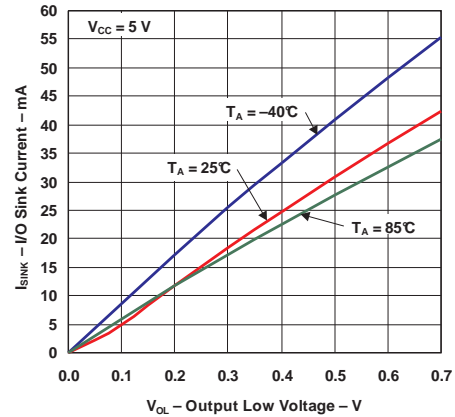

Figure 8. I/O Sink Current vs Output Low Voltage

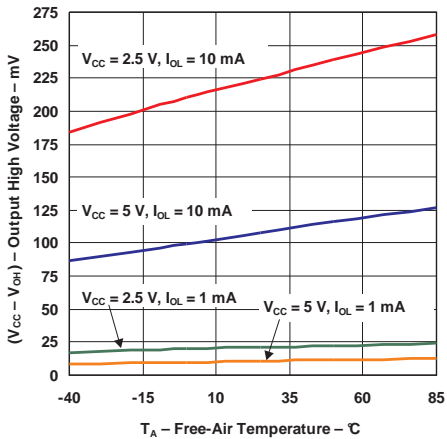

Figure 9. I/O Output High Voltage vs Temperature

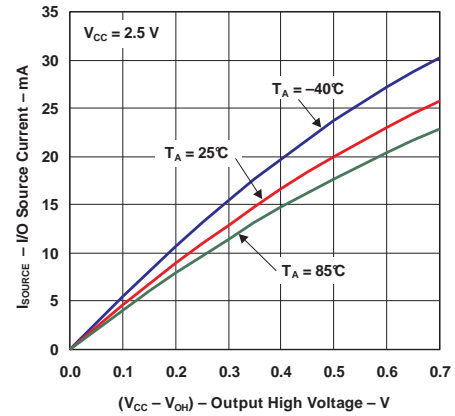

Figure 10. I/O Source Current vs Output High Voltage

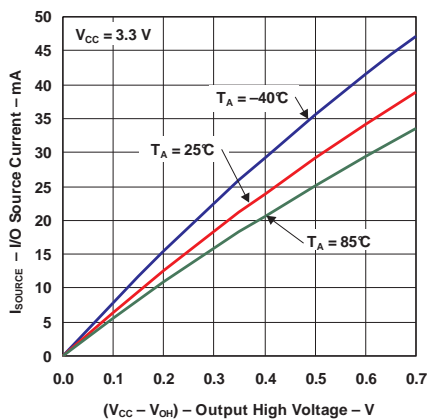

Figure 11. I/O Source Current vs Output High Voltage

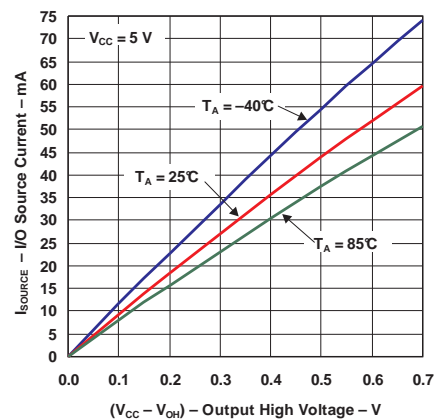

Figure 12. I/O Source Current vs Output High Voltage

Typical Characteristics (continued)

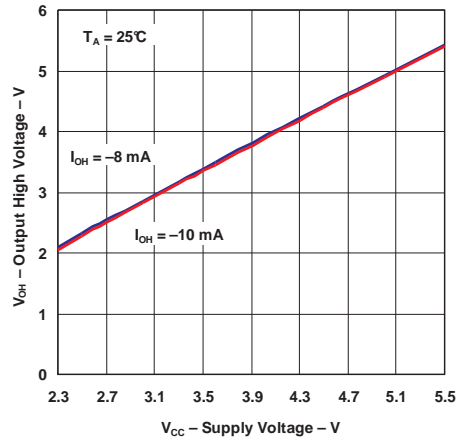
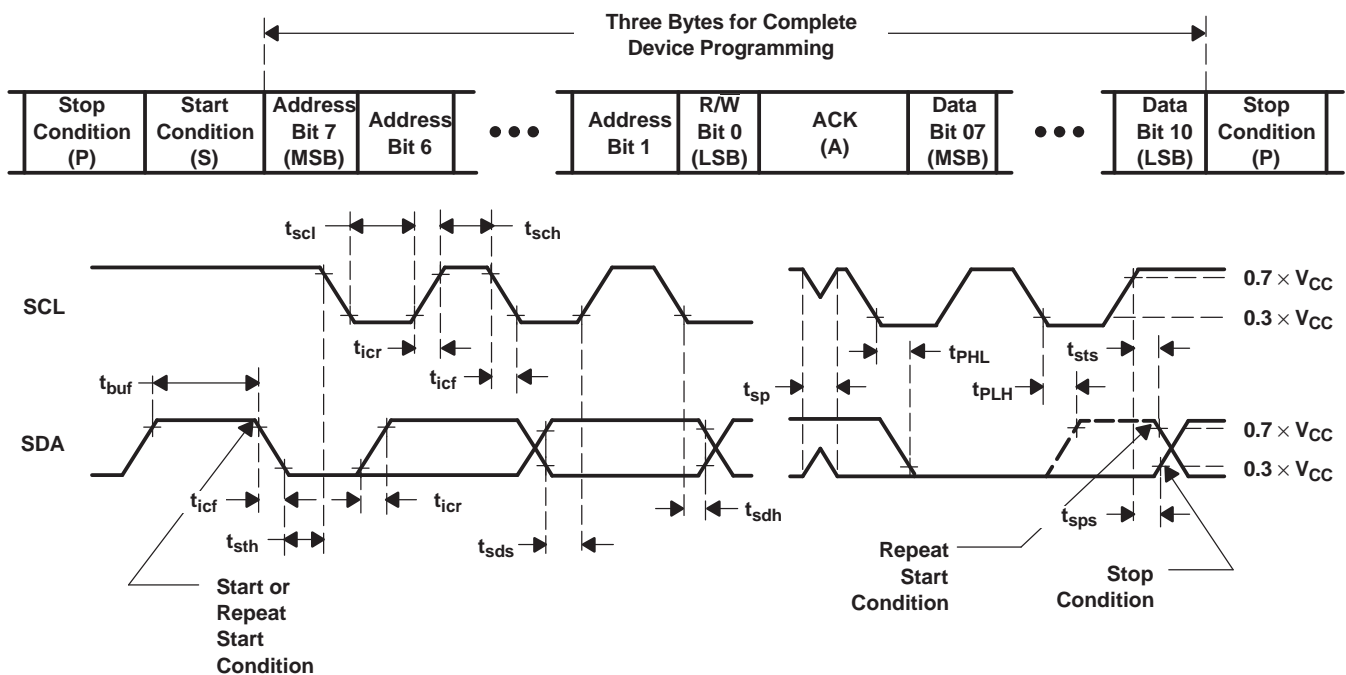

Figure 13. Output High Voltage vs Supply Voltage

7 Parameter Measurement Information



SDA LOAD CONFIGURATION



VOLTAGE WAVEFORMS

BYTE	DESCRIPTION
1	I ² C address
2, 3	P-port data

- A. C_L includes probe and jig capacitance.
- B. All inputs are supplied by generators having the following characteristics: $PRR \leq 10$ MHz, $Z_O = 50 \Omega$, $t_r/t_f \leq 30$ ns.
- C. All parameters and waveforms are not applicable to all devices.

Figure 14. I²C Interface Load Circuit And Voltage Waveforms

Parameter Measurement Information (continued)

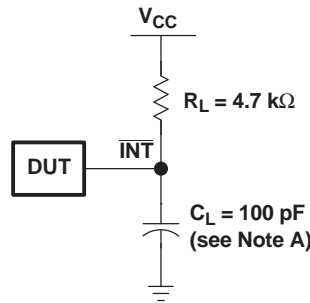

INTERRUPT LOAD CONFIGURATION

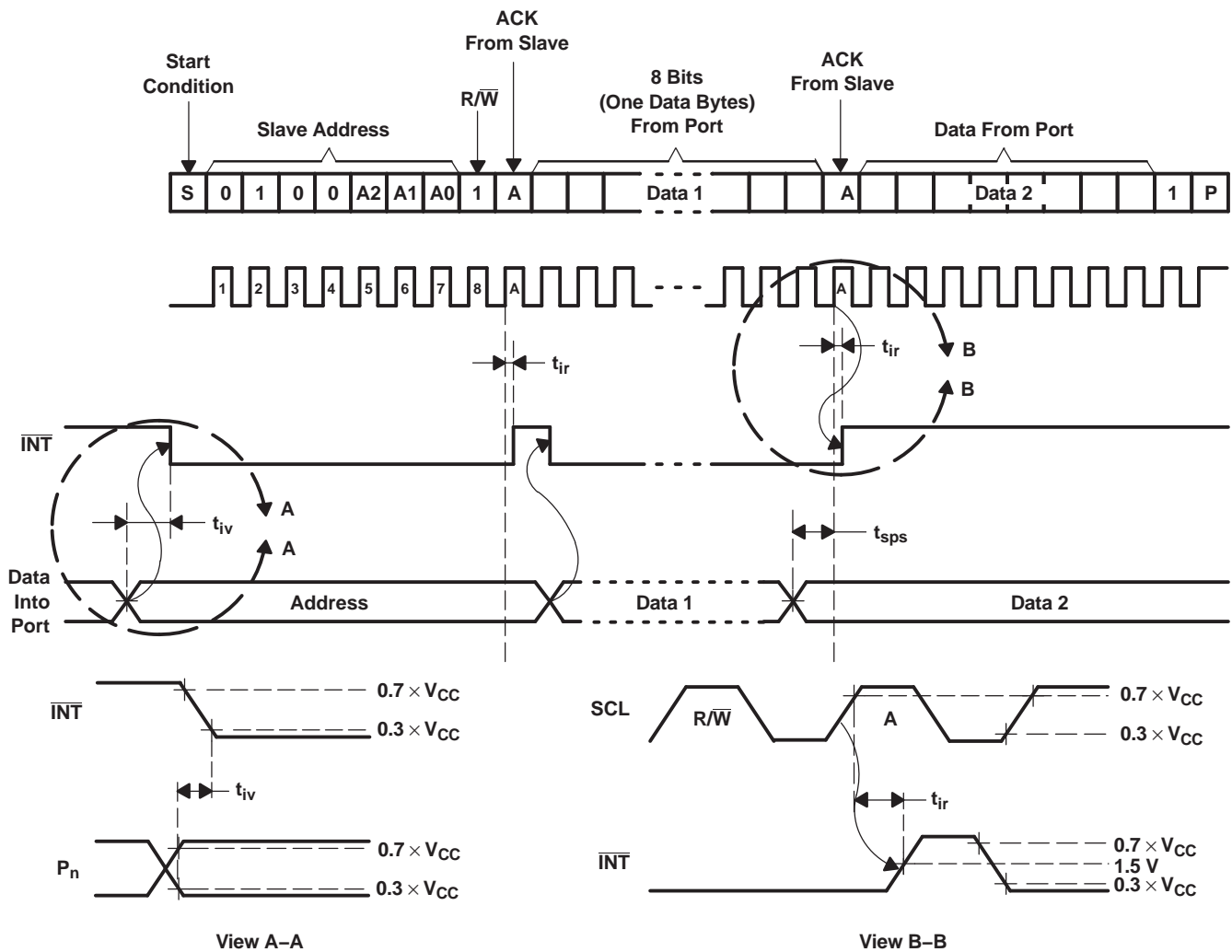

- A. C_L includes probe and jig capacitance.
- B. All inputs are supplied by generators having the following characteristics: PRR \leq 10 MHz, $Z_0 = 50 \Omega$, $t_r/t_f \leq 30$ ns.
- C. All parameters and waveforms are not applicable to all devices.

Figure 15. Interrupt Load Circuit And Voltage Waveforms

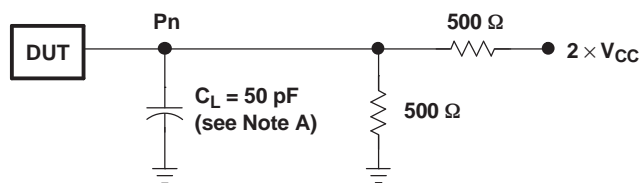
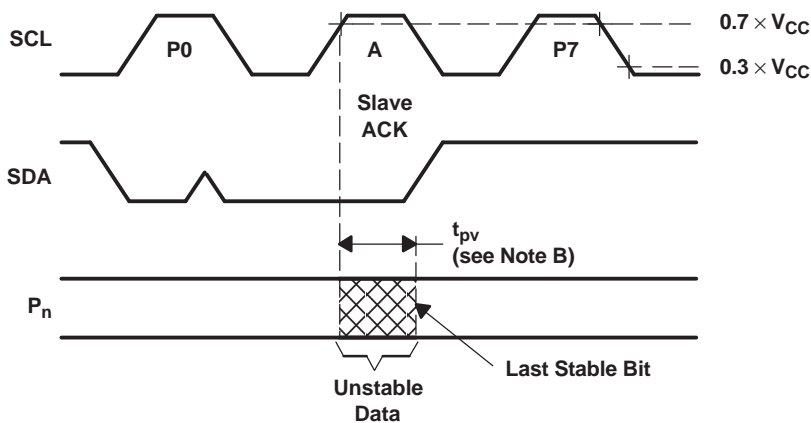
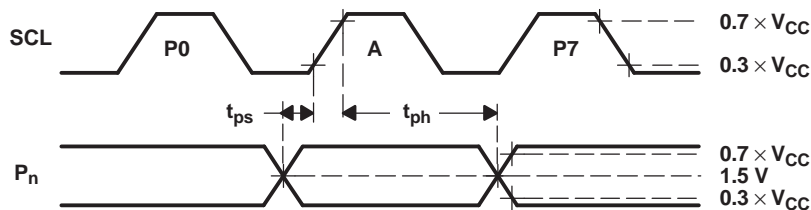
Parameter Measurement Information (continued)

P-PORT LOAD CONFIGURATION

WRITE MODE ($R/\bar{W} = 0$)

READ MODE ($R/\bar{W} = 1$)

- A. C_L includes probe and jig capacitance.
- B. t_{pv} is measured from $0.7 \times V_{CC}$ on SCL to 50% I/O pin output.
- C. All inputs are supplied by generators having the following characteristics: $PRR \leq 10$ MHz, $Z_O = 50 \Omega$, $t_r/t_f \leq 30$ ns.
- D. The outputs are measured one at a time, with one transition per measurement.
- E. All parameters and waveforms are not applicable to all devices.

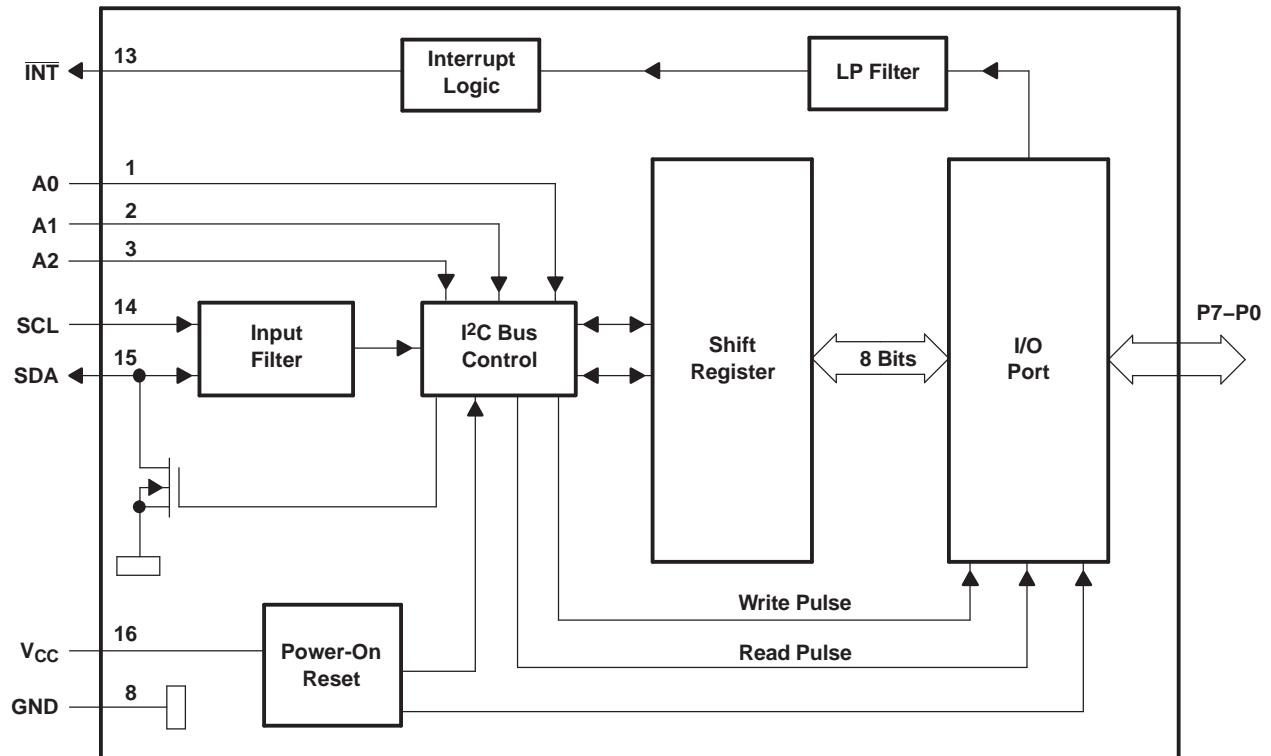
Figure 16. P-Port Load Circuit And Voltage Waveforms

8 Detailed Description

8.1 Functional Block Diagram



- A. Pin numbers shown are for the DB, DBQ, DGV, DW, N, or PW package.
- B. All I/Os are set to inputs at reset.

Figure 17. Logic Diagram

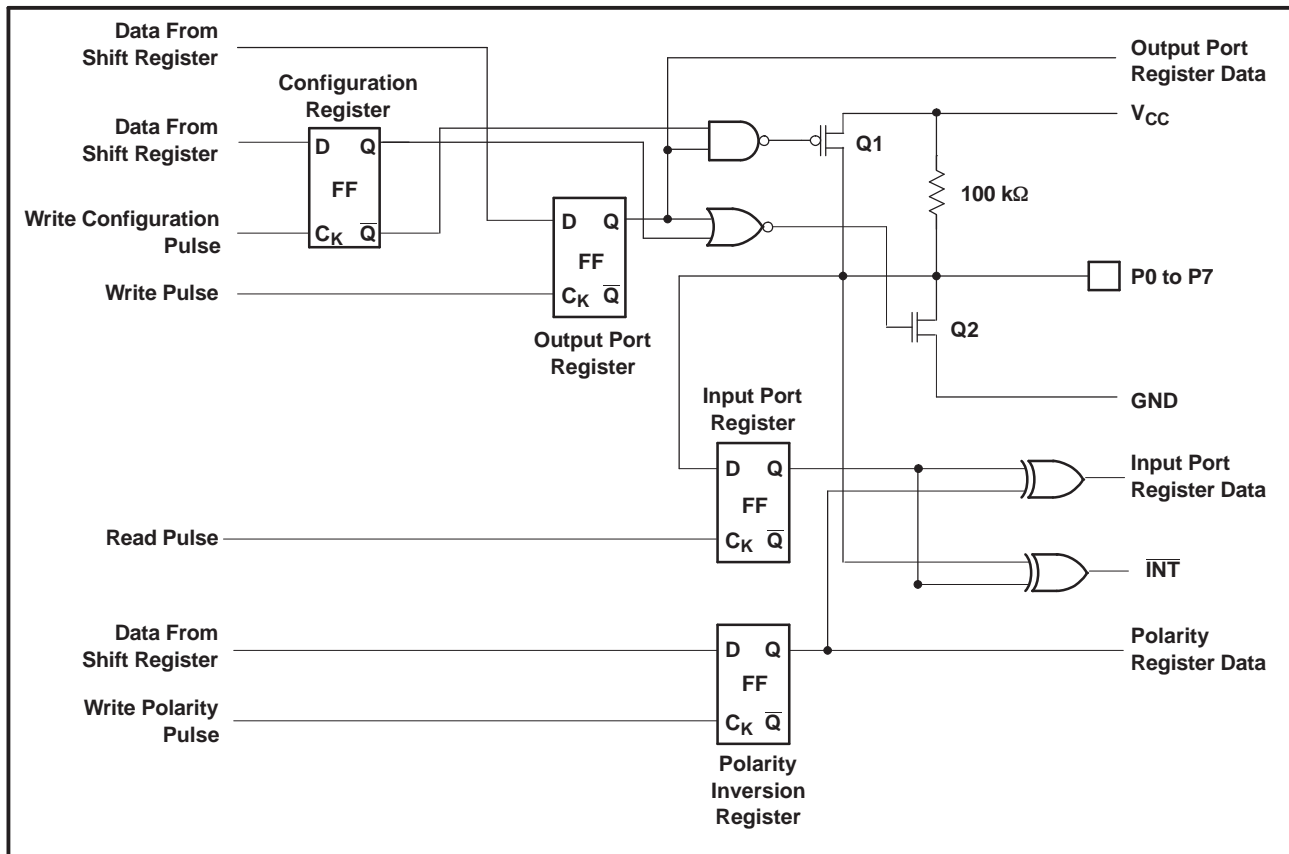
Functional Block Diagram (continued)

A. At power-on reset, all registers return to default values.

Figure 18. Simplified Schematic Of P0 To P7

8.2 Device Functional Modes

8.2.1 Power-On Reset

When power (from 0 V) is applied to V_{CC}, an internal power-on reset holds the PCA9554 in a reset condition until V_{CC} has reached V_{POR}. At that point, the reset condition is released and the PCA9554 registers and I²C/SMBus state machine initialize to their default states. After that, V_{CC} must be lowered to below 0.2 V and then back up to the operating voltage for a power-reset cycle.

Refer to the [Power-On Reset Errata](#) section.

8.2.2 I/O Port

When an I/O is configured as an input, FETs Q1 and Q2 (in [Figure 18](#)) are off, which creates a high-impedance input with a weak pullup (100 kΩ typ) to V_{CC}. The input voltage may be raised above V_{CC} to a maximum of 5.5 V.

If the I/O is configured as an output, Q1 or Q2 is enabled, depending on the state of the output port register. In this case, there are low-impedance paths between the I/O pin and either V_{CC} or GND. The external voltage applied to this I/O pin should not exceed the recommended levels for proper operation.

Device Functional Modes (continued)

8.2.3 Interrupt Output ($\overline{\text{INT}}$)

An interrupt is generated by any rising or falling edge of the port inputs in the input mode. After time, t_{IV} , the signal $\overline{\text{INT}}$ is valid. Resetting the interrupt circuit is achieved when data on the port is changed to the original setting, data is read from the port that generated the interrupt. Resetting occurs in the read mode at the acknowledge (ACK) or not acknowledge (NACK) bit after the rising edge of the SCL signal.

Interrupts that occur during the ACK or NACK clock pulse can be lost (or be very short) due to the resetting of the interrupt during this pulse. Each change of the I/Os after resetting is detected and is transmitted as $\overline{\text{INT}}$. Writing to another device does not affect the interrupt circuit, and a pin configured as an output cannot cause an interrupt. Changing an I/O from an output to an input may cause a false interrupt to occur, if the state of the pin does not match the contents of the Input Port register. Because each 8-pin port is read independently, the interrupt caused by port 0 is not cleared by a read of port 1 or vice versa.

The $\overline{\text{INT}}$ output has an open-drain structure and requires pullup resistor to V_{CC} .

8.2.3.1 Interrupt Errata

Description

The $\overline{\text{INT}}$ will be improperly de-asserted if the following two conditions occur:

1. The last I²C command byte (register pointer) written to the device was 00h.

NOTE

This generally means the last operation with the device was a Read of the input register. However, the command byte may have been written with 00h without ever going on to read the input register. After reading from the device, if no other command byte written, it will remain 00h.

2. Any other slave device on the I²C bus acknowledges an address byte with the R/W bit set high

System Impact

Can cause improper interrupt handling as the Master will see the interrupt as being cleared.

System Workaround

Minor software change: User must change command byte to something besides 00h after a Read operation to the PCA9554 device or before reading from another slave device.

NOTE

Software change will be compatible with other versions (competition and TI redesigns) of this device.

8.3 Programming

8.3.1 I²C Interface

The bidirectional I²C bus consists of the serial clock (SCL) and serial data (SDA) lines. Both lines must be connected to a positive supply through a pullup resistor when connected to the output stages of a device. Data transfer may be initiated only when the bus is not busy.

I²C communication with this device is initiated by a master sending a start condition, a high-to-low transition on the SDA input/output while the SCL input is high (see [Figure 19](#)). After the start condition, the device address byte is sent, MSB first, including the data direction bit (R/W).

After receiving the valid address byte, this device responds with an acknowledge (ACK), a low on the SDA input/output during the high of the ACK-related clock pulse. The address inputs (A0–A2) of the slave device must not be changed between the start and the stop conditions.

Programming (continued)

On the I²C bus, only one data bit is transferred during each clock pulse. The data on the SDA line must remain stable during the high pulse of the clock period, as changes in the data line at this time are interpreted as control commands (start or stop) (see [Figure 20](#)).

A Stop condition, a low-to-high transition on the SDA input/output while the SCL input is high, is sent by the master (see [Figure 19](#)).

Any number of data bytes can be transferred from the transmitter to the receiver between the start and the stop conditions. Each byte of eight bits is followed by one ACK bit. The transmitter must release the SDA line before the receiver can send an ACK bit. The device that acknowledges must pull down the SDA line during the ACK clock pulse so that the SDA line is stable low during the high pulse of the ACK-related clock period (see [Figure 21](#)). When a slave receiver is addressed, it must generate an ACK after each byte is received. Similarly, the master must generate an ACK after each byte that it receives from the slave transmitter. Setup and hold times must be met to ensure proper operation.

A master receiver will signal an end of data to the slave transmitter by not generating an acknowledge (NACK) after the last byte has been clocked out of the slave. This is done by the master receiver by holding the SDA line high. In this event, the transmitter must release the data line to enable the master to generate a Stop condition.

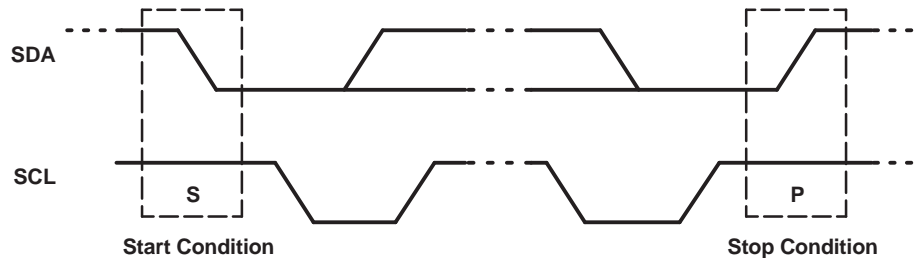

Figure 19. Definition Of Start And Stop Conditions

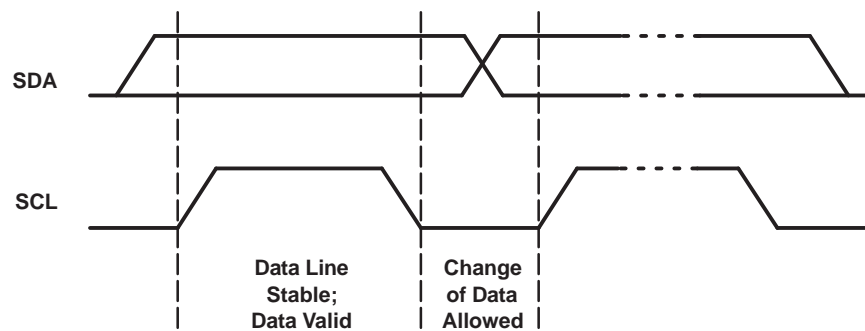

Figure 20. Bit Transfer

Programming (continued)

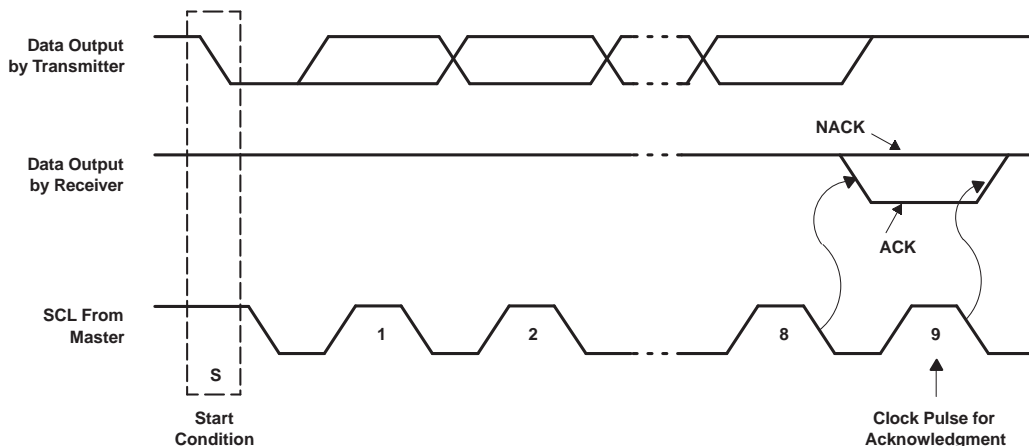

Figure 21. Acknowledgment On The I²C Bus

8.3.2 Register Map

Table 1. Interface Definition

BYTE	BIT							
	7 (MSB)	6	5	4	3	2	1	0 (LSB)
I ² C slave address	L	H	L	L	A2	A1	A0	R/W
Px I/O data bus	P7	P6	P5	P4	P3	P2	P1	P0

8.3.2.1 Device Address

Figure 22 shows the address byte for the PCA9554.

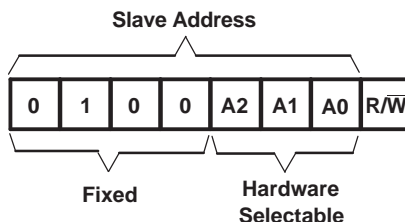

Figure 22. PCA9554 Address

Table 2. Address Reference

INPUTS			I ² C BUS SLAVE ADDRESS
A2	A1	A0	
L	L	L	32 (decimal), 20 (hexadecimal)
L	L	H	33 (decimal), 21 (hexadecimal)
L	H	L	34 (decimal), 22 (hexadecimal)
L	H	H	35 (decimal), 23 (hexadecimal)
H	L	L	36 (decimal), 24 (hexadecimal)
H	L	H	37 (decimal), 25 (hexadecimal)
H	H	L	38 (decimal), 26 (hexadecimal)
H	H	H	39 (decimal), 27 (hexadecimal)

The last bit of the slave address defines the operation (read or write) to be performed. When it is high (1), a read is selected, while a low (0) selects a write operation.

8.3.2.2 Control Register And Command Byte

Following the successful acknowledgment of the address byte, the bus master sends a command byte that is stored in the control register in the PCA9554. Two bits of this command byte state the operation (read or write) and the internal register (input, output, polarity inversion or configuration) that will be affected. This register can be written or read through the I²C bus. The command byte is sent only during a write transmission.

Once a command byte has been sent, the register that was addressed continues to be accessed by reads until a new command byte has been sent.

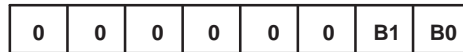

Figure 23. Control Register Bits

Table 3. Command Byte

CONTROL REGISTER BITS		COMMAND BYTE (HEX)	REGISTER	PROTOCOL	POWER-UP DEFAULT
B1	B0				
0	0	0x00	Input Port Register	Read byte	XXXX XXXX
0	1	0x01	Output Port Register	Read/write byte	1111 1111
1	0	0x02	Polarity Inversion Register	Read/write byte	0000 0000
1	1	0x03	Configuration Register	Read/write byte	1111 1111

8.3.2.3 Register Descriptions

The Input Port register (register 0) reflects the incoming logic levels of the pins, regardless of whether the pin is defined as an input or an output by the Configuration register. It only acts on read operation. Writes to these registers have no effect. The default value, X, is determined by the externally applied logic level.

Before a read operation, a write transmission is sent with the command byte to indicate to the I²C device that the Input Port register will be accessed next.

Table 4. Register 0 (Input Port Register) Table

BIT	I7	I6	I5	I4	I3	I2	I1	I0
DEFAULT	X	X	X	X	X	X	X	X

The Output Port register (register 1) shows the outgoing logic levels of the pins defined as outputs by the Configuration register. Bit values in this register have no effect on pins defined as inputs. In turn, reads from this register reflect the value that is in the flip-flop controlling the output selection, not the actual pin value.

Table 5. Register 1 (Output Port Register) Table

BIT	O7	O6	O5	O4	O3	O2	O1	O0
DEFAULT	1	1	1	1	1	1	1	1

The Polarity Inversion register (register 2) allows polarity inversion of pins defined as inputs by the Configuration register. If a bit in this register is set (written with 1), the corresponding port pin polarity is inverted. If a bit in this register is cleared (written with a 0), the corresponding port pin's original polarity is retained.

Table 6. Register 2 (Polarity Inversion Register) Table

BIT	N7	N6	N5	N4	N3	N2	N1	N0
DEFAULT	0	0	0	0	0	0	0	0

The Configuration register (register 3) configures the directions of the I/O pins. If a bit in this register is set to 1, the corresponding port pin is enabled as an input with high impedance output driver. If a bit in this register is cleared to 0, the corresponding port pin is enabled as an output.

Table 7. Register 3 (Configuration Register) Table

BIT	C7	C6	C5	C4	C3	C2	C1	C0
DEFAULT	1	1	1	1	1	1	1	1

8.3.2.4 Bus Transactions

Data is exchanged between the master and PCA9554 through write and read commands.

8.3.2.4.1 Writes

Data is transmitted to the PCA9554 by sending the device address and setting the least-significant bit to a logic 0 (see Figure 22 for device address). The command byte is sent after the address and determines which register receives the data that follows the command byte. There is no limitation on the number of data bytes sent in one write transmission.

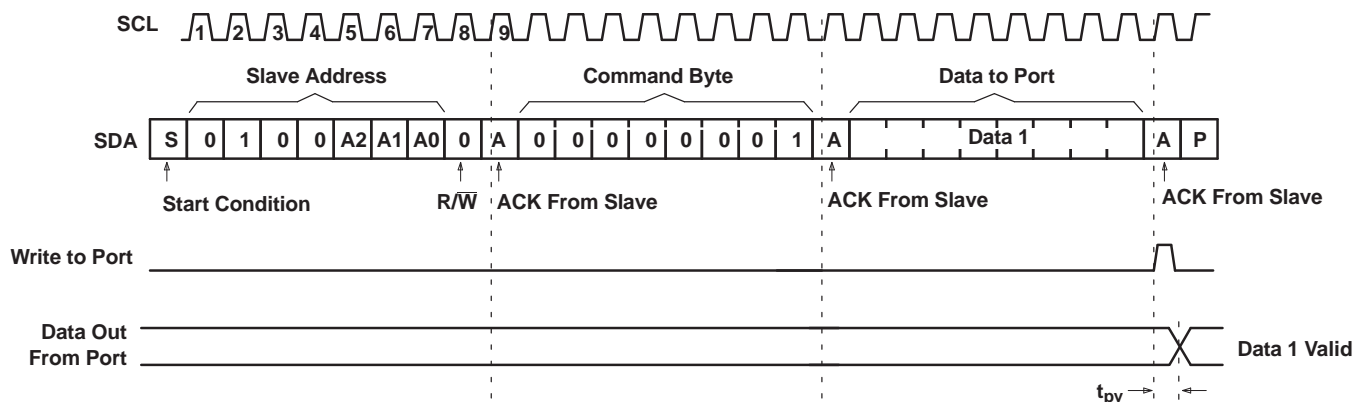

Figure 24. Write To Output Port Register

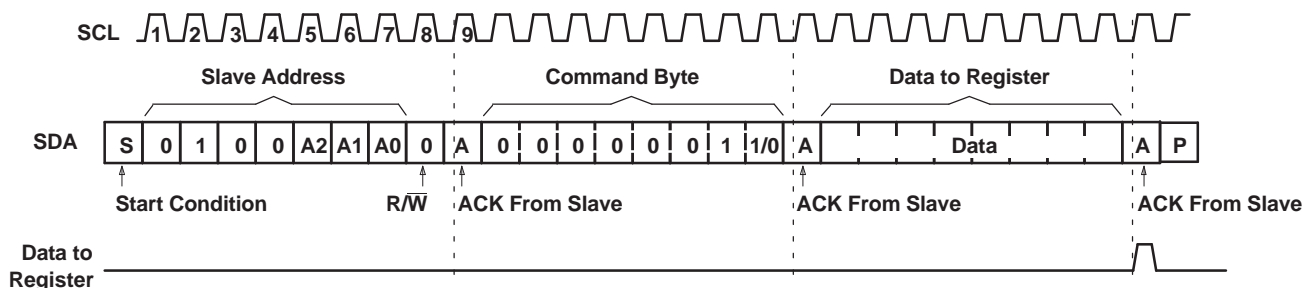

Figure 25. Write To Configuration Or Polarity Inversion Registers

8.3.2.4.2 Reads

The bus master first must send the PCA9554 address with the least-significant bit set to a logic 0 (see Figure 22 for device address). The command byte is sent after the address and determines which register is accessed. After a restart, the device address is sent again but, this time, the least-significant bit is set to a logic 1. Data from the register defined by the command byte then is sent by the PCA9554 (see Figure 26 and Figure 27). After a restart, the value of the register defined by the command byte matches the register being accessed when the restart occurred. Data is clocked into the register on the rising edge of the ACK clock pulse. There is no limitation on the number of data bytes received in one read transmission, but when the final byte is received, the bus master must not acknowledge the data

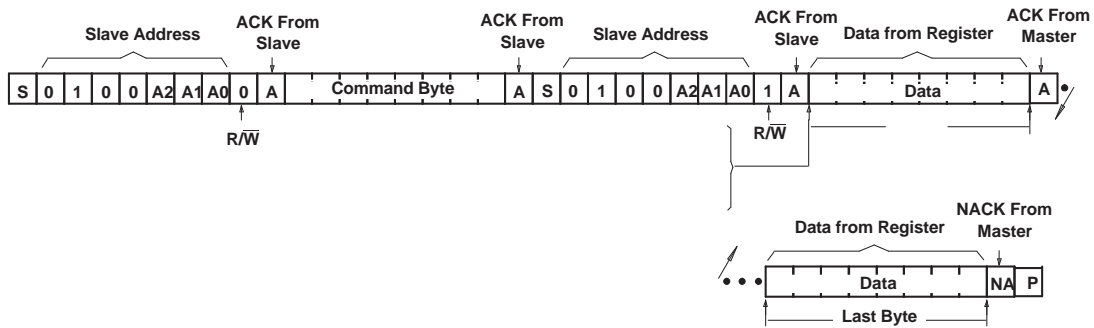
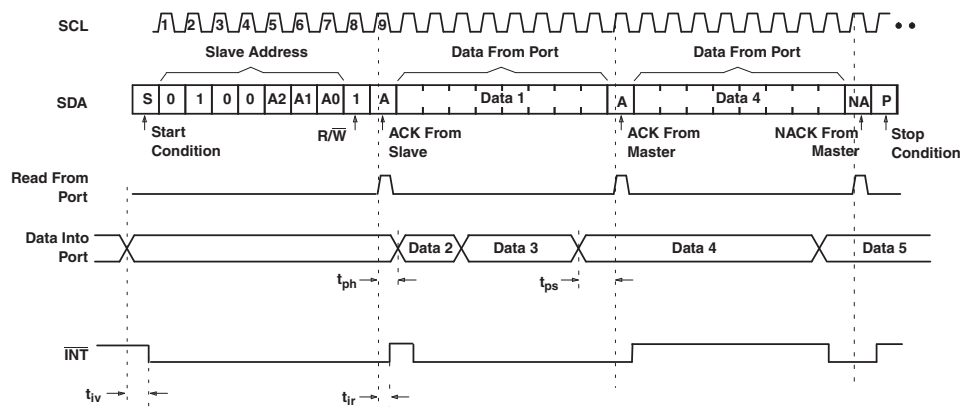

Figure 26. Read From Register



- A. This figure assumes the command byte has previously been programmed with 00h.
- B. Transfer of data can be stopped at any moment by a Stop condition.
- C. This figure eliminates the command byte transfer, a restart, and slave address call between the initial slave address call and actual data transfer from P port. See [Figure 26](#) for these details.

Figure 27. Read From Input Port Register

9 Application And Implementation

9.1 Typical Application

Figure 28 shows an application in which the PCA9554 can be used.

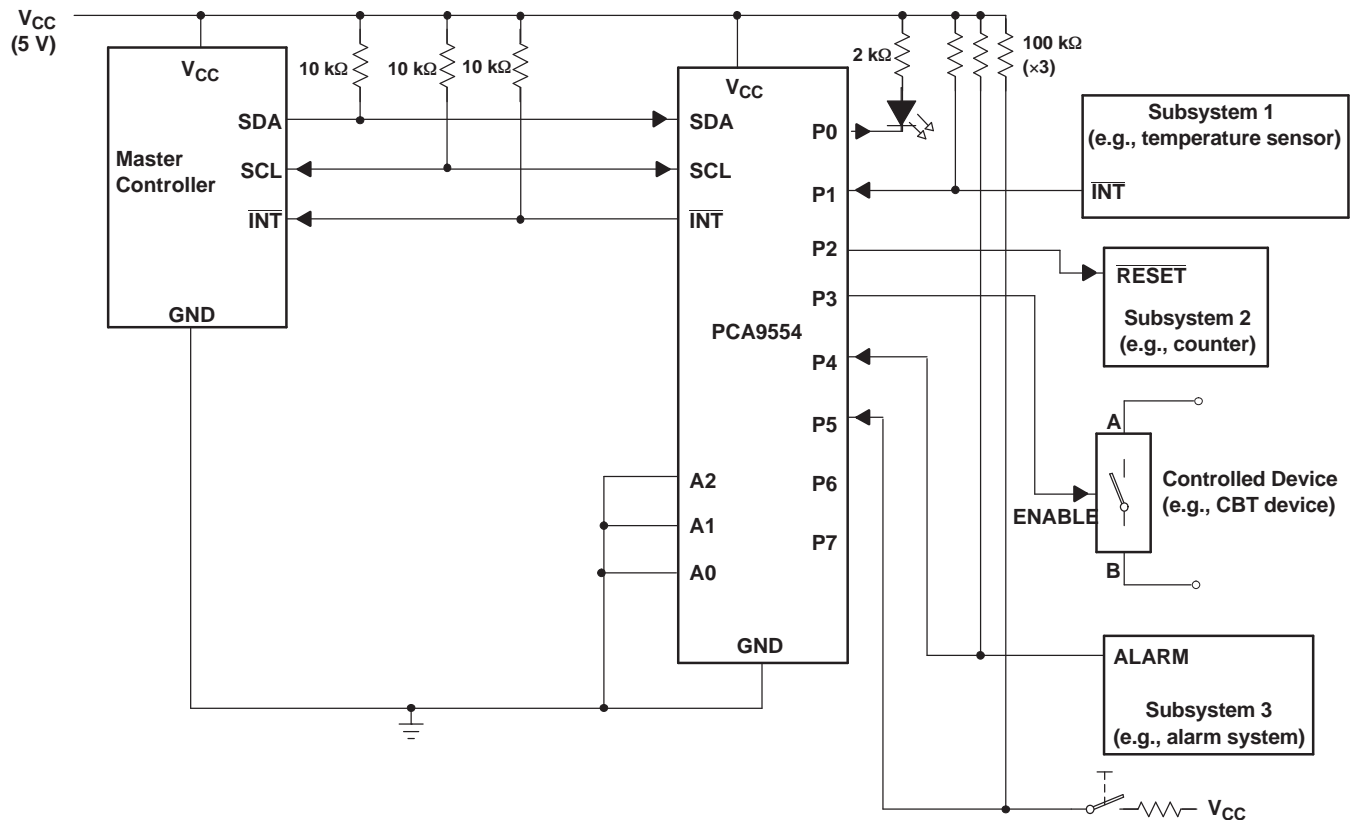

- Device address is configured as 0100000 for this example.
- P0, P2, and P3 are configured as outputs.
- P1, P4, and P5 are configured as inputs.
- P6 and P7 are not used and have internal 100-kΩ pullup resistors to protect them from floating.

Figure 28. Typical Application

Typical Application (continued)

9.1.1 Design Requirements

9.1.1.1 Minimizing I_{CC} When I/Os Control Leds

When the I/Os are used to control LEDs, they are normally connected to V_{CC} through a resistor as shown in Figure 28. The LED acts as a diode, so when the LED is off, the I/O V_{IN} is about 1.2 V less than V_{CC} . ΔI_{CC} in *Electrical Characteristics* shows how I_{CC} increases as V_{IN} becomes lower than V_{CC} .

For battery-powered applications, it is essential that the voltage of I/O pins is greater than or equal to V_{CC} when the LED is off to minimize current consumption. Figure 29 shows a high-value resistor in parallel with the LED. Figure 30 shows V_{CC} less than the LED supply voltage by at least 1.2 V. Both of these methods maintain the I/O V_{IN} at or above V_{CC} and prevent additional supply-current consumption when the LED is off.

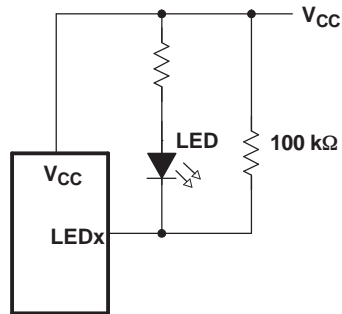

Figure 29. High-Value Resistor In Parallel With Led

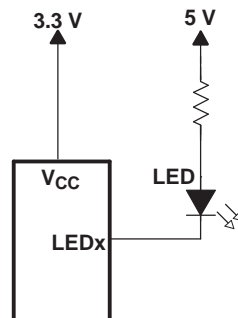
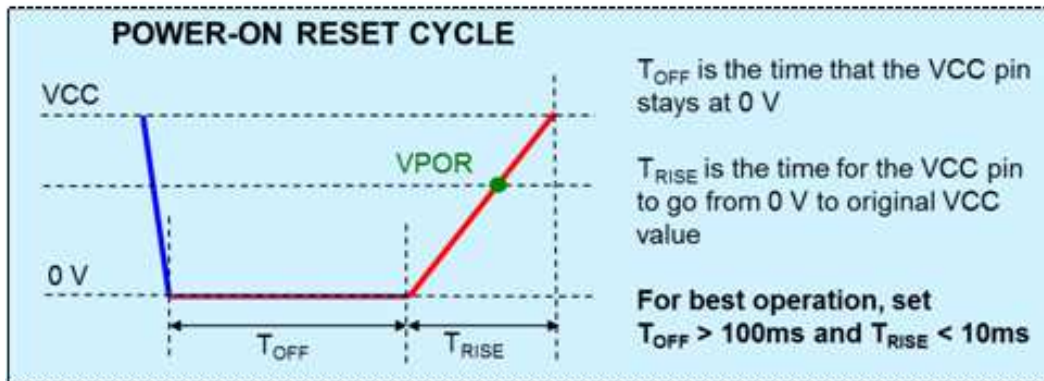

Figure 30. Device Supplied By A Lower Voltage

10 Power Supply Recommendations

10.1 Power-On Reset Errata

A power-on reset condition can be missed if the VCC ramps are outside specification listed below.



System Impact

If ramp conditions are outside timing allowances above, POR condition can be missed, causing the device to lock up.

11 Device and Documentation Support

11.1 Trademarks

All trademarks are the property of their respective owners.

11.2 Electrostatic Discharge Caution



These devices have limited built-in ESD protection. The leads should be shorted together or the device placed in conductive foam during storage or handling to prevent electrostatic damage to the MOS gates.

11.3 Glossary

[SLYZ022](#) — *TI Glossary*.

This glossary lists and explains terms, acronyms, and definitions.

12 Mechanical, Packaging, and Orderable Information

The following pages include mechanical, packaging, and orderable information. This information is the most current data available for the designated devices. This data is subject to change without notice and revision of this document. For browser-based versions of this data sheet, refer to the left-hand navigation.

PACKAGING INFORMATION

Orderable Device	Status (1)	Package Type	Package Drawing	Pins	Package Qty	Eco Plan (2)	Lead/Ball Finish (6)	MSL Peak Temp (3)	Op Temp (°C)	Device Marking (4/5)	Samples
PCA9554DB	ACTIVE	SSOP	DB	16	80	Green (RoHS & no Sb/Br)	CU NIPDAU	Level-1-260C-UNLIM	-40 to 85	PD554	Samples
PCA9554DBR	ACTIVE	SSOP	DB	16	2000	Green (RoHS & no Sb/Br)	CU NIPDAU	Level-1-260C-UNLIM	-40 to 85	PD554	Samples
PCA9554DGVR	ACTIVE	TVSOP	DGV	16	2000	Green (RoHS & no Sb/Br)	CU NIPDAU	Level-1-260C-UNLIM	-40 to 85	PD554	Samples
PCA9554DW	ACTIVE	SOIC	DW	16	40	Green (RoHS & no Sb/Br)	CU NIPDAU	Level-1-260C-UNLIM	-40 to 85	PCA9554	Samples
PCA9554DWR	ACTIVE	SOIC	DW	16	2000	Green (RoHS & no Sb/Br)	CU NIPDAU	Level-1-260C-UNLIM	-40 to 85	PCA9554	Samples
PCA9554PW	NRND	TSSOP	PW	16	90	Green (RoHS & no Sb/Br)	CU NIPDAU	Level-1-260C-UNLIM	-40 to 85	PD554	
PCA9554PWG4	NRND	TSSOP	PW	16	90	Green (RoHS & no Sb/Br)	CU NIPDAU	Level-1-260C-UNLIM	-40 to 85	PD554	
PCA9554PWR	NRND	TSSOP	PW	16	2000	Green (RoHS & no Sb/Br)	CU NIPDAU	Level-1-260C-UNLIM	-40 to 85	PD554	
PCA9554PWRG4	NRND	TSSOP	PW	16	2000	Green (RoHS & no Sb/Br)	CU NIPDAU	Level-1-260C-UNLIM	-40 to 85	PD554	

(1) The marketing status values are defined as follows:

ACTIVE: Product device recommended for new designs.

LIFEBUY: TI has announced that the device will be discontinued, and a lifetime-buy period is in effect.

NRND: Not recommended for new designs. Device is in production to support existing customers, but TI does not recommend using this part in a new design.

PREVIEW: Device has been announced but is not in production. Samples may or may not be available.

OBSOLETE: TI has discontinued the production of the device.

(2) Eco Plan - The planned eco-friendly classification: Pb-Free (RoHS), Pb-Free (RoHS Exempt), or Green (RoHS & no Sb/Br) - please check <http://www.ti.com/productcontent> for the latest availability information and additional product content details.

TBD: The Pb-Free/Green conversion plan has not been defined.

Pb-Free (RoHS): TI's terms "Lead-Free" or "Pb-Free" mean semiconductor products that are compatible with the current RoHS requirements for all 6 substances, including the requirement that lead not exceed 0.1% by weight in homogeneous materials. Where designed to be soldered at high temperatures, TI Pb-Free products are suitable for use in specified lead-free processes.

Pb-Free (RoHS Exempt): This component has a RoHS exemption for either 1) lead-based flip-chip solder bumps used between the die and package, or 2) lead-based die adhesive used between the die and leadframe. The component is otherwise considered Pb-Free (RoHS compatible) as defined above.

Green (RoHS & no Sb/Br): TI defines "Green" to mean Pb-Free (RoHS compatible), and free of Bromine (Br) and Antimony (Sb) based flame retardants (Br or Sb do not exceed 0.1% by weight in homogeneous material)

- (3) MSL, Peak Temp. - The Moisture Sensitivity Level rating according to the JEDEC industry standard classifications, and peak solder temperature.
- (4) There may be additional marking, which relates to the logo, the lot trace code information, or the environmental category on the device.
- (5) Multiple Device Markings will be inside parentheses. Only one Device Marking contained in parentheses and separated by a "~" will appear on a device. If a line is indented then it is a continuation of the previous line and the two combined represent the entire Device Marking for that device.
- (6) Lead/Ball Finish - Orderable Devices may have multiple material finish options. Finish options are separated by a vertical ruled line. Lead/Ball Finish values may wrap to two lines if the finish value exceeds the maximum column width.

Important Information and Disclaimer:The information provided on this page represents TI's knowledge and belief as of the date that it is provided. TI bases its knowledge and belief on information provided by third parties, and makes no representation or warranty as to the accuracy of such information. Efforts are underway to better integrate information from third parties. TI has taken and continues to take reasonable steps to provide representative and accurate information but may not have conducted destructive testing or chemical analysis on incoming materials and chemicals. TI and TI suppliers consider certain information to be proprietary, and thus CAS numbers and other limited information may not be available for release.

In no event shall TI's liability arising out of such information exceed the total purchase price of the TI part(s) at issue in this document sold by TI to Customer on an annual basis.

TAPE AND REEL INFORMATION

QUADRANT ASSIGNMENTS FOR PIN 1 ORIENTATION IN TAPE

*All dimensions are nominal

Device	Package Type	Package Drawing	Pins	SPQ	Reel Diameter (mm)	Reel Width W1 (mm)	A0 (mm)	B0 (mm)	K0 (mm)	P1 (mm)	W (mm)	Pin1 Quadrant
PCA9554DGVR	TVSOP	DGV	16	2000	330.0	12.4	6.8	4.0	1.6	8.0	12.0	Q1
PCA9554DWR	SOIC	DW	16	2000	330.0	16.4	10.75	10.7	2.7	12.0	16.0	Q1
PCA9554PWR	TSSOP	PW	16	2000	330.0	12.4	6.9	5.6	1.6	8.0	12.0	Q1

TAPE AND REEL BOX DIMENSIONS



*All dimensions are nominal

Device	Package Type	Package Drawing	Pins	SPQ	Length (mm)	Width (mm)	Height (mm)
PCA9554DGVR	TVSOP	DGV	16	2000	367.0	367.0	35.0
PCA9554DWR	SOIC	DW	16	2000	350.0	350.0	43.0
PCA9554PWR	TSSOP	PW	16	2000	367.0	367.0	35.0

EXAMPLE BOARD LAYOUT

PW0016A

TSSOP - 1.2 mm max height

SMALL OUTLINE PACKAGE



LAND PATTERN EXAMPLE
EXPOSED METAL SHOWN
SCALE: 10X



4220204/A 02/2017

NOTES: (continued)

- 6. Publication IPC-7351 may have alternate designs.
- 7. Solder mask tolerances between and around signal pads can vary based on board fabrication site.

EXAMPLE STENCIL DESIGN

PW0016A

TSSOP - 1.2 mm max height

SMALL OUTLINE PACKAGE

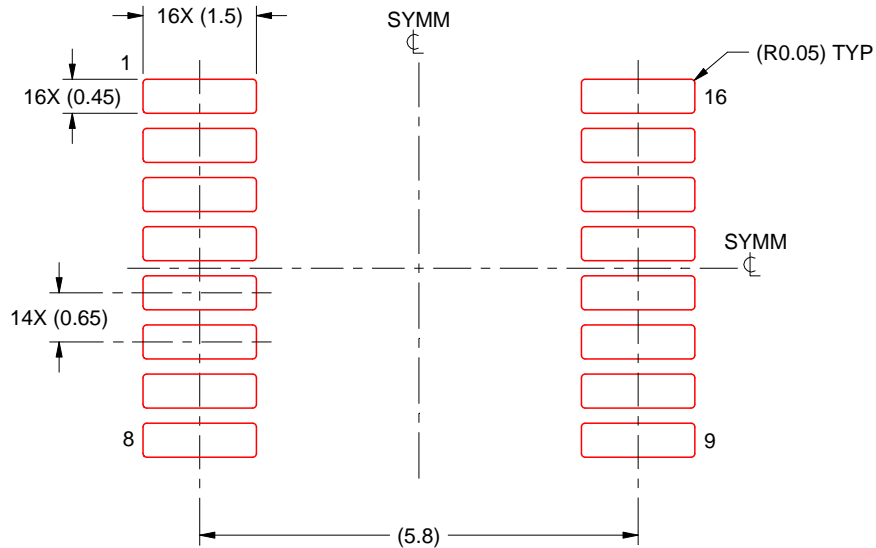

SOLDER PASTE EXAMPLE
BASED ON 0.125 mm THICK STENCIL
SCALE: 10X

4220204/A 02/2017

NOTES: (continued)

8. Laser cutting apertures with trapezoidal walls and rounded corners may offer better paste release. IPC-7525 may have alternate design recommendations.
9. Board assembly site may have different recommendations for stencil design.

GENERIC PACKAGE VIEW

DW 16

SOIC - 2.65 mm max height

7.5 x 10.3, 1.27 mm pitch

SMALL OUTLINE INTEGRATED CIRCUIT

This image is a representation of the package family, actual package may vary.
Refer to the product data sheet for package details.

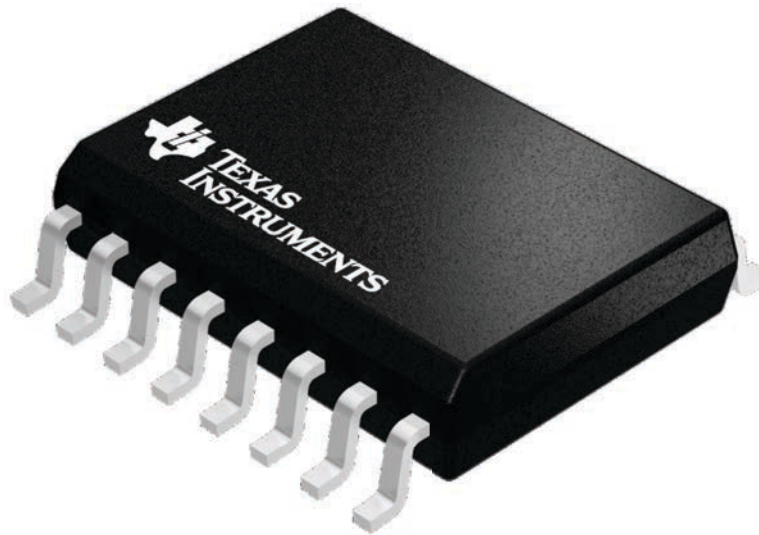

4224780/A



DW0016A

PACKAGE OUTLINE

SOIC - 2.65 mm max height

SOIC

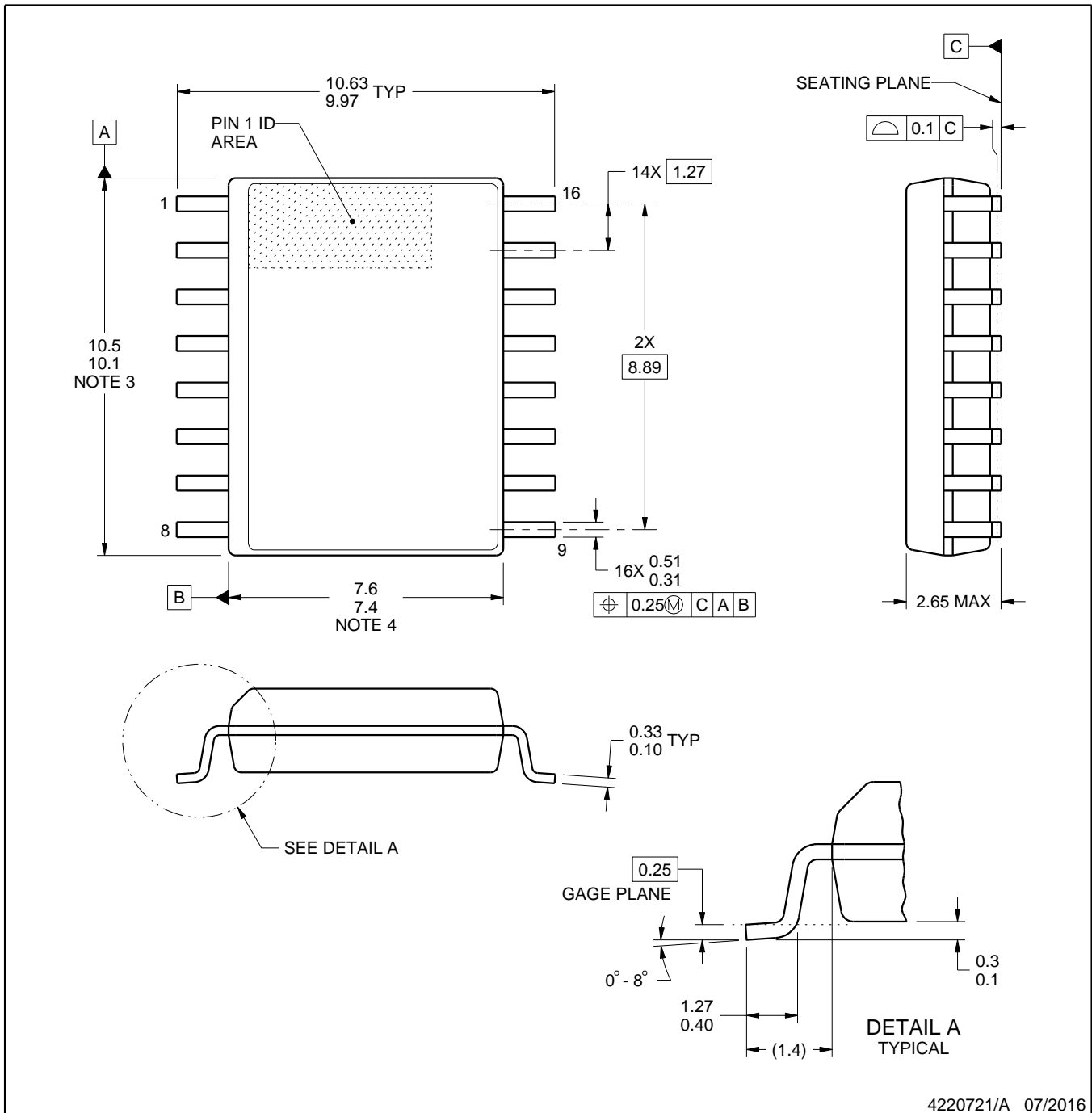

4220721/A 07/2016

NOTES:

1. All linear dimensions are in millimeters. Dimensions in parenthesis are for reference only. Dimensioning and tolerancing per ASME Y14.5M.
2. This drawing is subject to change without notice.
3. This dimension does not include mold flash, protrusions, or gate burrs. Mold flash, protrusions, or gate burrs shall not exceed 0.15 mm, per side.
4. This dimension does not include interlead flash. Interlead flash shall not exceed 0.25 mm, per side.
5. Reference JEDEC registration MS-013.

EXAMPLE BOARD LAYOUT

DW0016A

SOIC - 2.65 mm max height

SOIC

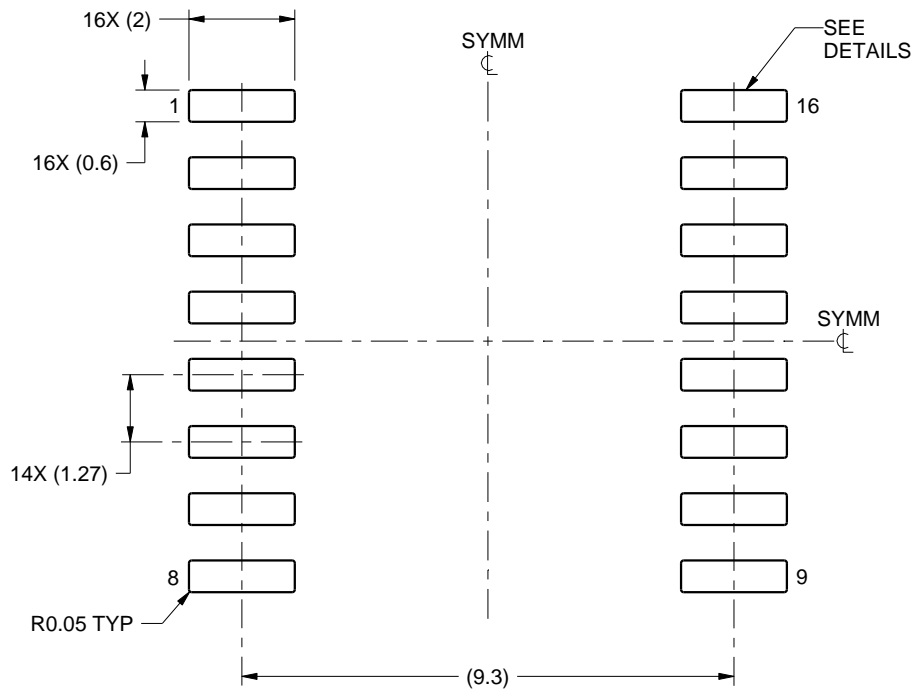

LAND PATTERN EXAMPLE
SCALE:7X



SOLDER MASK DETAILS

4220721/A 07/2016

NOTES: (continued)

6. Publication IPC-7351 may have alternate designs.

7. Solder mask tolerances between and around signal pads can vary based on board fabrication site.

EXAMPLE STENCIL DESIGN

DW0016A

SOIC - 2.65 mm max height

SOIC



SOLDER PASTE EXAMPLE
BASED ON 0.125 mm THICK STENCIL
SCALE:7X

4220721/A 07/2016

NOTES: (continued)

8. Laser cutting apertures with trapezoidal walls and rounded corners may offer better paste release. IPC-7525 may have alternate design recommendations.
9. Board assembly site may have different recommendations for stencil design.

DB (R-PDSO-G**)

PLASTIC SMALL-OUTLINE

28 PINS SHOWN



- NOTES: A. All linear dimensions are in millimeters.
 B. This drawing is subject to change without notice.
 C. Body dimensions do not include mold flash or protrusion not to exceed 0,15.
 D. Falls within JEDEC MO-150

IMPORTANT NOTICE AND DISCLAIMER

TI PROVIDES TECHNICAL AND RELIABILITY DATA (INCLUDING DATASHEETS), DESIGN RESOURCES (INCLUDING REFERENCE DESIGNS), APPLICATION OR OTHER DESIGN ADVICE, WEB TOOLS, SAFETY INFORMATION, AND OTHER RESOURCES "AS IS" AND WITH ALL FAULTS, AND DISCLAIMS ALL WARRANTIES, EXPRESS AND IMPLIED, INCLUDING WITHOUT LIMITATION ANY IMPLIED WARRANTIES OF MERCHANTABILITY, FITNESS FOR A PARTICULAR PURPOSE OR NON-INFRINGEMENT OF THIRD PARTY INTELLECTUAL PROPERTY RIGHTS.

These resources are intended for skilled developers designing with TI products. You are solely responsible for (1) selecting the appropriate TI products for your application, (2) designing, validating and testing your application, and (3) ensuring your application meets applicable standards, and any other safety, security, or other requirements. These resources are subject to change without notice. TI grants you permission to use these resources only for development of an application that uses the TI products described in the resource. Other reproduction and display of these resources is prohibited. No license is granted to any other TI intellectual property right or to any third party intellectual property right. TI disclaims responsibility for, and you will fully indemnify TI and its representatives against, any claims, damages, costs, losses, and liabilities arising out of your use of these resources.

TI's products are provided subject to TI's Terms of Sale (www.ti.com/legal/termsofsale.html) or other applicable terms available either on ti.com or provided in conjunction with such TI products. TI's provision of these resources does not expand or otherwise alter TI's applicable warranties or warranty disclaimers for TI products.

Mailing Address: Texas Instruments, Post Office Box 655303, Dallas, Texas 75265
Copyright © 2019, Texas Instruments Incorporated

Looking for pricing, stock, or lifecycle information?

Click below to explore more details on WIN SOURCE:

 [View PCA9554DWR on WIN SOURCE](#)

 [Texas Instruments](#) Information

Optimize Your Supply Chain with WIN SOURCE Solutions

-  Global Sourcing Solution
-  Obsolete Management
-  Cost Control Management
-  Shortage Management
-  Alternative Solution
-  Excess Inventory Management