



PCA9553

4-bit I²C-bus LED driver with programmable blink rates

Rev. 06 — 29 December 2008

Product data sheet

1. General description

The PCA9553 LED blinker blinks LEDs in I²C-bus and SMBus applications where it is necessary to limit bus traffic or free up the I²C-bus master's (MCU, MPU, DSP, chip set, etc.) timer. The uniqueness of this device is the internal oscillator with two programmable blink rates. To blink LEDs using normal I/O expanders like the PCF8574 or PCA9554, the bus master must send repeated commands to turn the LED on and off. This greatly increases the amount of traffic on the I²C-bus and uses up one of the master's timers. The PCA9553 LED blinker instead requires only the initial set-up command to program BLINK RATE 1 and BLINK RATE 2 (i.e., the frequency and duty cycle). From then on, only one command from the bus master is required to turn each individual open-drain output ON, OFF, or to cycle at BLINK RATE 1 or BLINK RATE 2. Maximum output sink current is 25 mA per bit and 100 mA per package.

Any bits not used for controlling the LEDs can be used for General Purpose Parallel Input/Output (GPIO) expansion.

Power-On Reset (POR) initializes the registers to their default state, all zeroes, causing the bits to be set HIGH (LED off).

Due to pin limitations, the PCA9553 is not featured with hardware address pins. The PCA9553/01 and the PCA9553/02 have different fixed I²C-bus addresses allowing operation of both on the same bus.

2. Features

- 4 LED drivers (on, off, flashing at a programmable rate)
- 2 selectable, fully programmable blink rates (frequency and duty cycle) between 0.172 Hz and 44 Hz (5.82 seconds and 0.023 seconds)
- Input/outputs not used as LED drivers can be used as regular GPIOs
- Internal oscillator requires no external components
- I²C-bus interface logic compatible with SMBus
- Internal power-on reset
- Noise filter on SCL/SDA inputs
- 4 open-drain outputs directly drive LEDs to 25 mA
- Controlled edge rates to minimize ground bounce
- No glitch on power-up
- Supports hot insertion
- Low standby current
- Operating power supply voltage range of 2.3 V to 5.5 V
- 0 Hz to 400 kHz clock frequency

- ESD protection exceeds 2000 V HBM per JESD22-A114, 150 V MM per JESD22-A115 and 1000 V CDM per JESD22-C101
- Latch-up testing is done to JEDEC Standard JESD78 which exceeds 100 mA
- Packages offered: SO8, TSSOP8 (MSOP8), HVSON8

3. Ordering information

Table 1. Ordering information

Type number	Package		Version
	Name	Description	
PCA9553D/01	SO8	plastic small outline package; 8 leads; body width 3.9 mm	SOT96-1
PCA9553D/02			
PCA9553DP/01	TSSOP8 ^[1]	plastic thin shrink small outline package; 8 leads; body width 3 mm	SOT505-1
PCA9553DP/02			
PCA9553TK ^[2]	HVSON8	plastic thermal enhanced very thin small outline package; no leads; 8 terminals; body 3 × 3 × 0.85 mm	SOT908-1
PCA9553TK/02			

[1] Also known as MSOP8.

[2] PCA9553TK uses version /01 address.

4. Marking

Table 2. Marking codes

Type number	Marking code
PCA9553D/01	9553/1
PCA9553D/02	9553/2
PCA9553DP/01	P53/1
PCA9553DP/02	P53/2
PCA9553TK	P53/1
PCA9553TK/02	P53/2

5. Block diagram

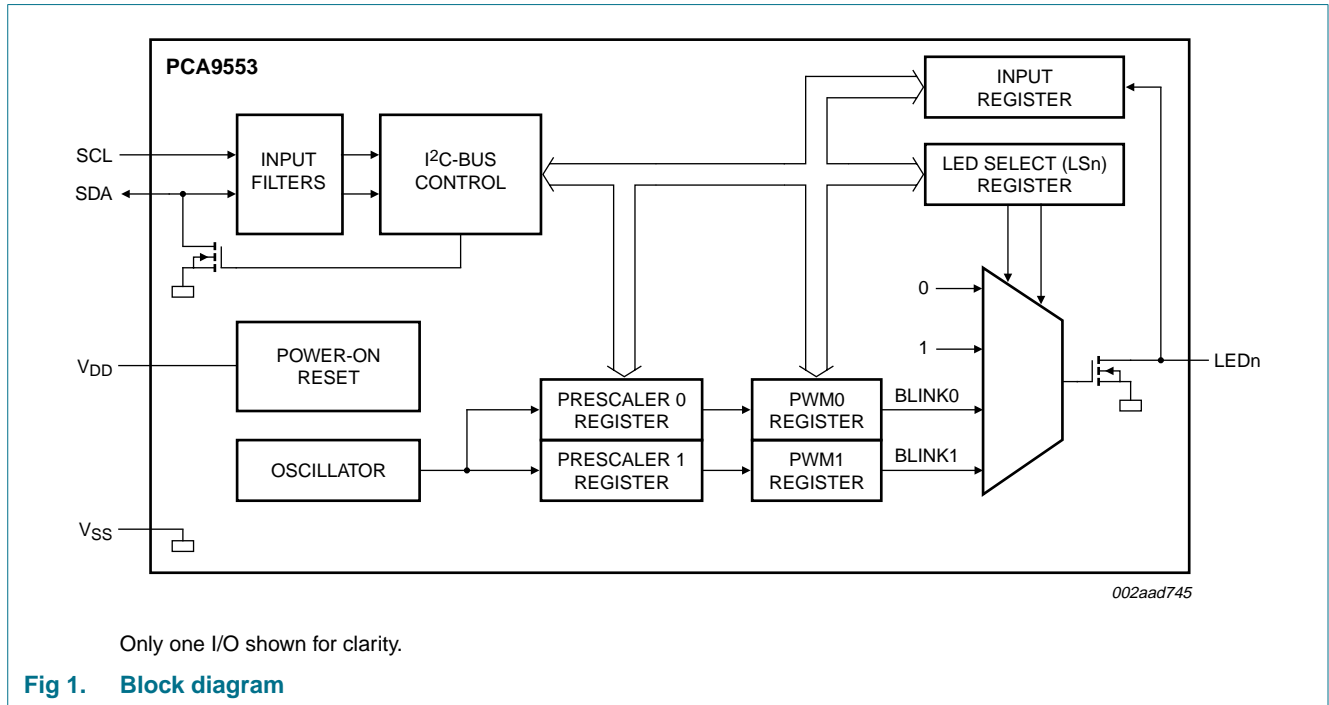
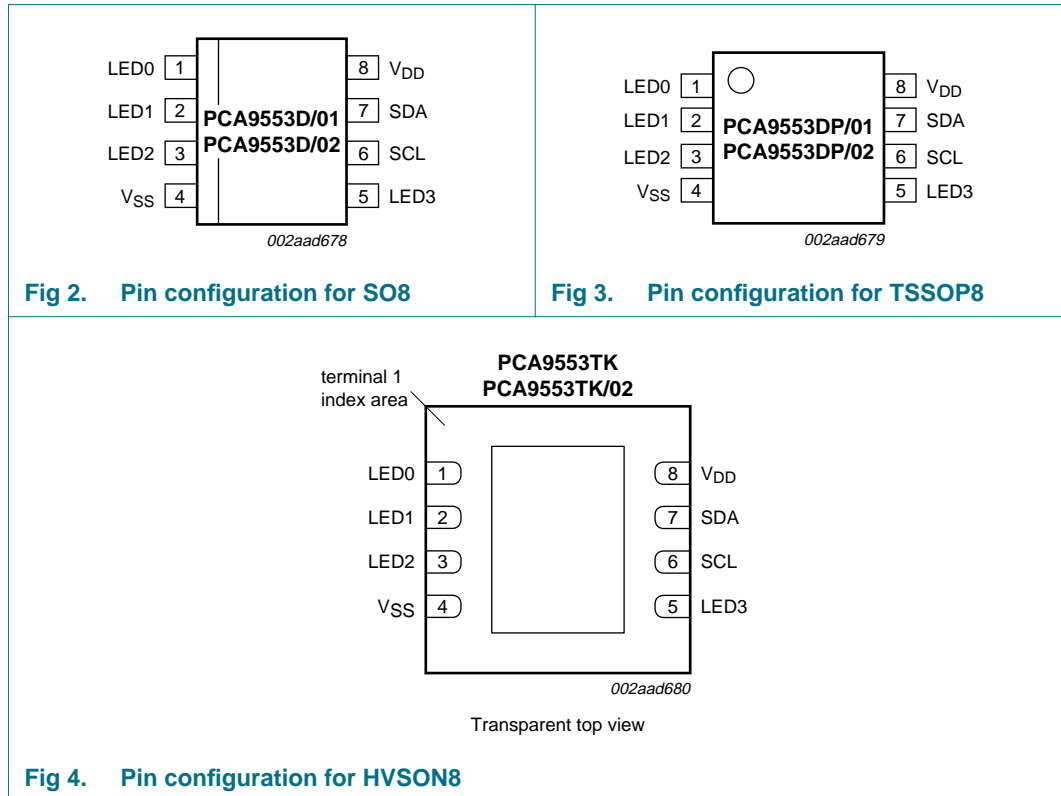

Fig 1. Block diagram

6. Pinning information

6.1 Pinning



6.2 Pin description

Table 3. Pin description

Symbol	Pin	Description
LED0	1	LED driver 0
LED1	2	LED driver 1
LED2	3	LED driver 2
V _{SS}	4 ^[1]	supply ground
LED3	5	LED driver 3
SCL	6	serial clock line
SDA	7	serial data line
V _{DD}	8	supply voltage

[1] HVSON8 package die supply ground is connected to both V_{SS} pin and exposed center pad. V_{SS} pin must be connected to supply ground for proper device operation. For enhanced thermal, electrical, and board level performance, the exposed pad needs to be soldered to the board using a corresponding thermal pad on the board and for proper heat conduction through the board, thermal vias need to be incorporated in the PCB in the thermal pad region.

7. Functional description

Refer to [Figure 1 “Block diagram”](#).

7.1 Device address

Following a START condition the bus master must output the address of the slave it is accessing. The address of the PCA9553/01 is shown in [Figure 5](#) and PCA9553/02 in [Figure 6](#).

PCA9553TK uses the version /01 address.

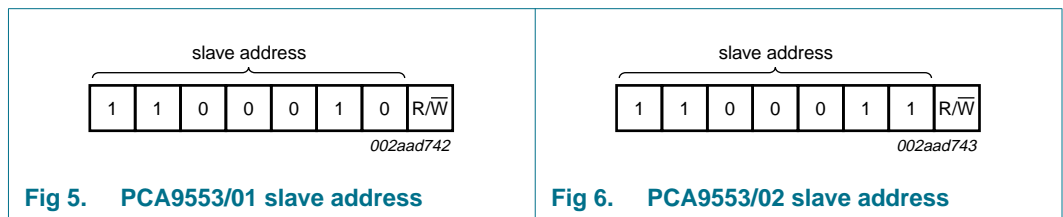

The last bit of the address byte defines the operation to be performed. When set to logic 1 a read is selected, while a logic 0 selects a write operation.

7.2 Control register

Following the successful acknowledgement of the slave address, the bus master will send a byte to the PCA9553 which will be stored in the Control register.

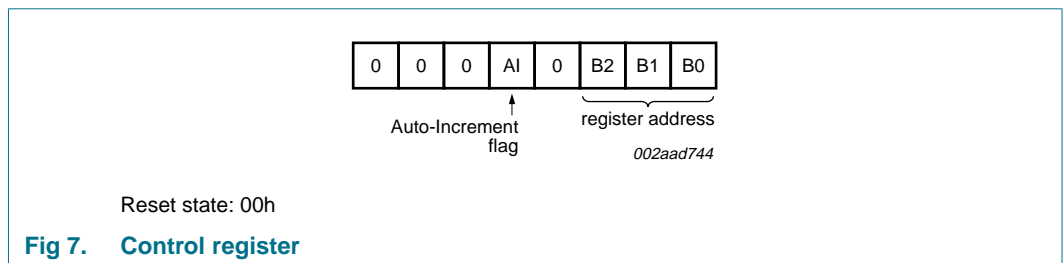

The lowest 3 bits are used as a pointer to determine which register will be accessed.

If the Auto-Increment flag is set, the three low order bits of the Control register are automatically incremented after a read or write. This allows the user to program the registers sequentially. The contents of these bits will rollover to ‘000’ after the last register is accessed.

When the Auto-Increment flag is set (AI = 1) and a read sequence is initiated, the sequence must start by reading a register different from ‘0’ (B2 B1 B0 ≠ 0 0 0).

Only the 3 least significant bits are affected by the AI flag.

Unused bits must be programmed with zeroes.

Table 4. Control register definition

B2	B1	B0	Register name	Type	Register function
0	0	0	INPUT	read	input register
0	0	1	PSC0	read/write	frequency prescaler 0
0	1	0	PWM0	read/write	PWM register 0
0	1	1	PSC1	read/write	frequency prescaler 1
1	0	0	PWM1	read/write	PWM register 1
1	0	1	LS0	read/write	LED selector

7.3 Register descriptions

7.3.1 INPUT - Input register

The INPUT register reflects the state of the device pins. Writes to this register will be acknowledged but will have no effect.

Table 5. INPUT - Input register description

Bit	7	6	5	4	3	2	1	0
Symbol	INPUT[7]	INPUT[6]	INPUT[5]	INPUT[4]	LED3	LED2	LED1	LED0
Default	0	0	0	0	X	X	X	X

Remark: The default value 'X' is determined by the externally applied logic level (normally logic 1) when used for directly driving LED with pull-up to V_{DD}.

7.3.2 PSC0 - Frequency Prescaler 0

PSC0 is used to program the period of the PWM output.

The period of BLINK0 = (PSC0 + 1) / 44.

Table 6. PSC0 - Frequency Prescaler 0 register description

Bit	7	6	5	4	3	2	1	0
Symbol	PSC0[7]	PSC0[6]	PSC0[5]	PSC0[4]	PSC0[3]	PSC0[2]	PSC0[1]	PSC0[0]
Default	1	1	1	1	1	1	1	1

7.3.3 PWM0 - Pulse Width Modulation 0

The PWM0 register determines the duty cycle of BLINK0. The outputs are LOW (LED off) when the count is less than the value in PWM0 and HIGH when it is greater. If PWM0 is programmed with 00h, then the PWM0 output is always LOW.

The duty cycle of BLINK0 = (256 – PWM0) / 256.

Table 7. PWM0 - Pulse Width Modulation 0 register description

Bit	7	6	5	4	3	2	1	0
Symbol	PWM0 [7]	PWM0 [6]	PWM0 [5]	PWM0 [4]	PWM0 [3]	PWM0 [2]	PWM0 [1]	PWM0 [0]
Default	1	0	0	0	0	0	0	0

7.3.4 PSC1 - Frequency Prescaler 1

PSC1 is used to program the period of the PWM output.

The period of BLINK1 = (PSC1 + 1) / 44.

Table 8. PSC1 - Frequency Prescaler 1 register description

Bit	7	6	5	4	3	2	1	0
Symbol	PSC1[7]	PSC1[6]	PSC1[5]	PSC1[4]	PSC1[3]	PSC1[2]	PSC1[1]	PSC1[0]
Default	1	1	1	1	1	1	1	1

7.3.5 PWM1 - Pulse Width Modulation 1

The PWM1 register determines the duty cycle of BLINK1. The outputs are LOW (LED off) when the count is less than the value in PWM1 and HIGH when it is greater. If PWM1 is programmed with 00h, then the PWM1 output is always LOW.

The duty cycle of BLINK1 = (256 – PWM1) / 256.

Table 9. PWM1 - Pulse Width Modulation 1 register description

Bit	7	6	5	4	3	2	1	0
Symbol	PWM1 [7]	PWM1 [6]	PWM1 [5]	PWM1 [4]	PWM1 [3]	PWM1 [2]	PWM1 [1]	PWM1 [0]
Default	1	0	0	0	0	0	0	0

7.3.6 LS0 - LED selector register

The LS0 LED select register determines the source of the LED data.

- 00 = output is set LOW (LED on)
- 01 = output is set high-impedance (LED off; default)
- 10 = output blinks at PWM0 rate
- 11 = output blinks at PWM1 rate

Table 10. LS0 - LED selector register bit description

Legend: * default value.

Register	Bit	Value	Description
LS0 - LED0 to LED3 selector			
LS0	7:6	01*	LED3 selected
	5:4	01*	LED2 selected
	3:2	01*	LED1 selected
	1:0	01*	LED0 selected

7.4 Pins used as general purpose I/Os

LED pins not used to control LEDs can be used as general purpose I/Os.

For use as input: Set LED_n to high-impedance (01) and then read the pin state via the Input register.

For use as output: Connect external pull-up resistor to the pin and size it according to the DC recommended operating characteristics. LED output pin is HIGH when the output is programmed as high-impedance, and LOW when the output is programmed LOW through the 'LED selector' register. The output can be pulse-width controlled when PWM0 or PWM1 are used.

7.5 Power-on reset

When power is applied to V_{DD} , an internal Power-On Reset (POR) holds the PCA9553 in a reset condition until V_{DD} has reached V_{POR} . At that point, the reset condition is released and the PCA9553 registers are initialized to their default states, with all outputs in the OFF state. Thereafter, V_{DD} must be lowered below 0.2 V to reset the device.

8. Characteristics of the I²C-bus

The I²C-bus is for 2-way, 2-line communication between different ICs or modules. The two lines are a serial data line (SDA) and a serial clock line (SCL). Both lines must be connected to a positive supply via a pull-up resistor when connected to the output stages of a device. Data transfer may be initiated only when the bus is not busy.

8.1 Bit transfer

One data bit is transferred during each clock pulse. The data on the SDA line must remain stable during the HIGH period of the clock pulse as changes in the data line at this time will be interpreted as control signals (see [Figure 8](#)).

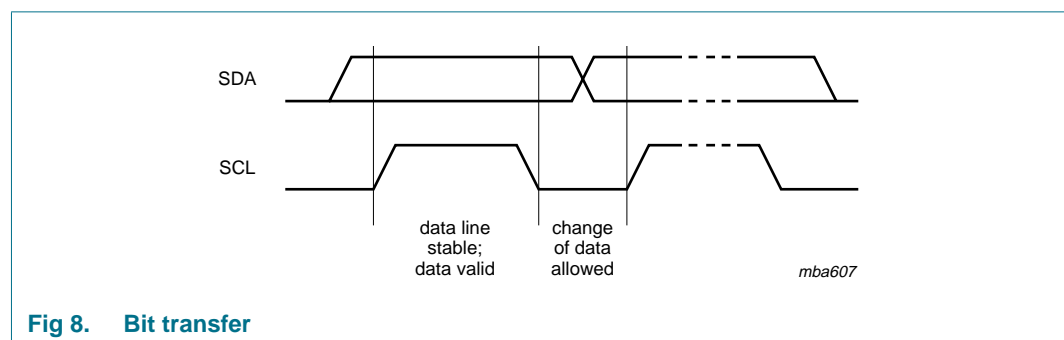

8.1.1 START and STOP conditions

Both data and clock lines remain HIGH when the bus is not busy. A HIGH-to-LOW transition of the data line while the clock is HIGH is defined as the START condition (S). A LOW-to-HIGH transition of the data line while the clock is HIGH is defined as the STOP condition (P) (see [Figure 9](#)).

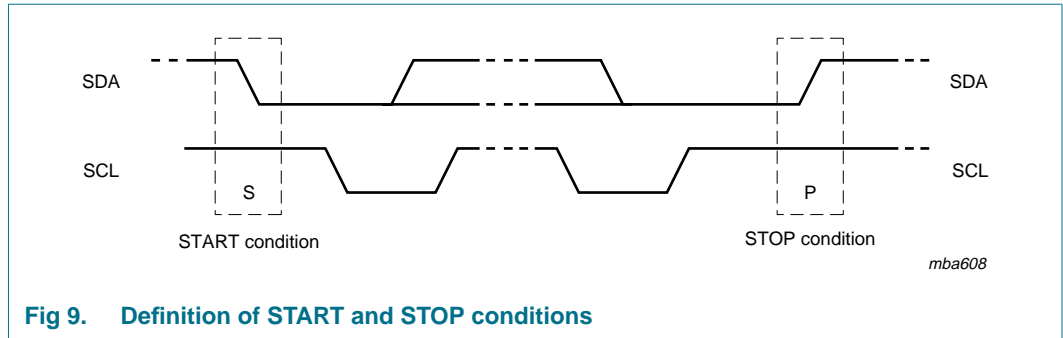

8.2 System configuration

A device generating a message is a ‘transmitter’; a device receiving is the ‘receiver’. The device that controls the message is the ‘master’ and the devices which are controlled by the master are the ‘slaves’ (see [Figure 10](#)).

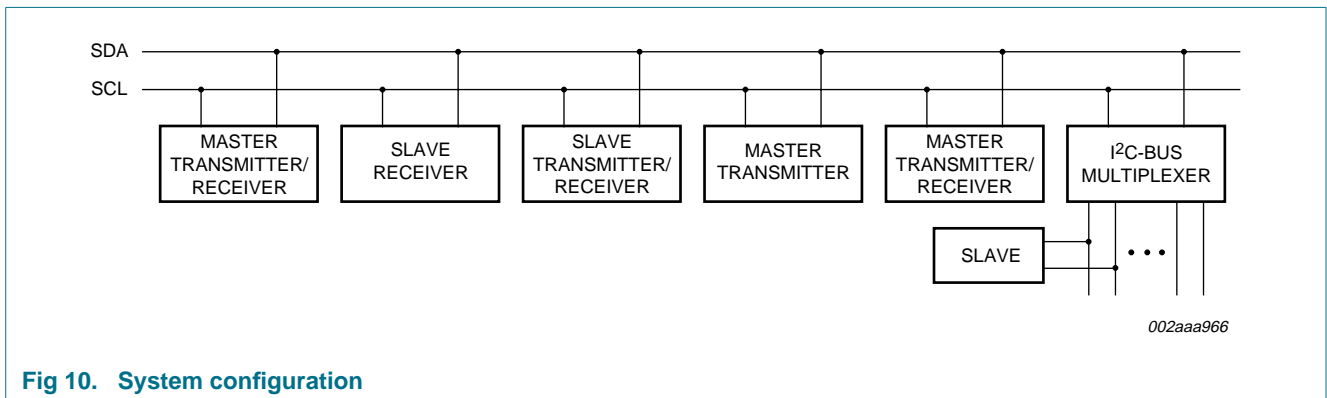

8.3 Acknowledge

The number of data bytes transferred between the START and the STOP conditions from transmitter to receiver is not limited. Each byte of eight bits is followed by one acknowledge bit. The acknowledge bit is a HIGH level put on the bus by the transmitter, whereas the master generates an extra acknowledge related clock pulse.

A slave receiver which is addressed must generate an acknowledge after the reception of each byte. Also a master must generate an acknowledge after the reception of each byte that has been clocked out of the slave transmitter. The device that acknowledges has to pull down the SDA line during the acknowledge clock pulse, so that the SDA line is stable LOW during the HIGH period of the acknowledge related clock pulse; set-up time and hold time must be taken into account.

A master receiver must signal an end of data to the transmitter by not generating an acknowledge on the last byte that has been clocked out of the slave. In this event, the transmitter must leave the data line HIGH to enable the master to generate a STOP condition.

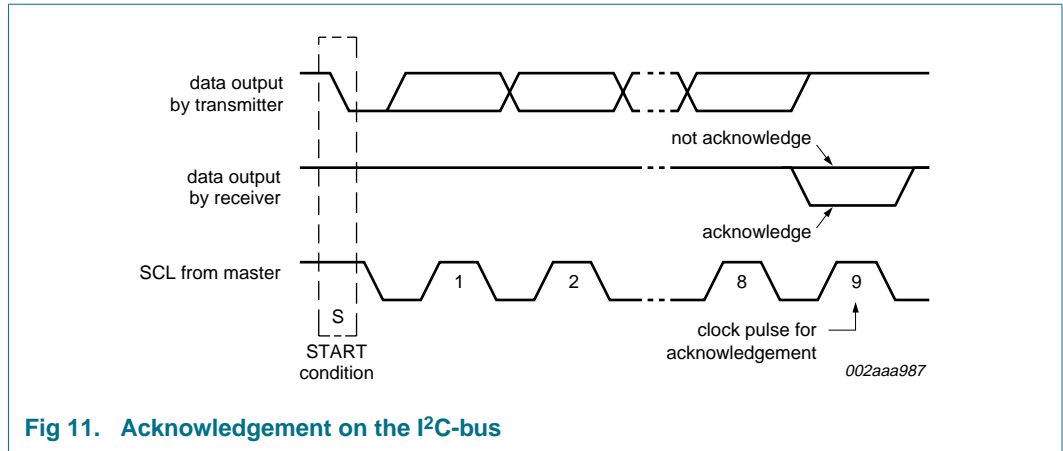

8.4 Bus transactions

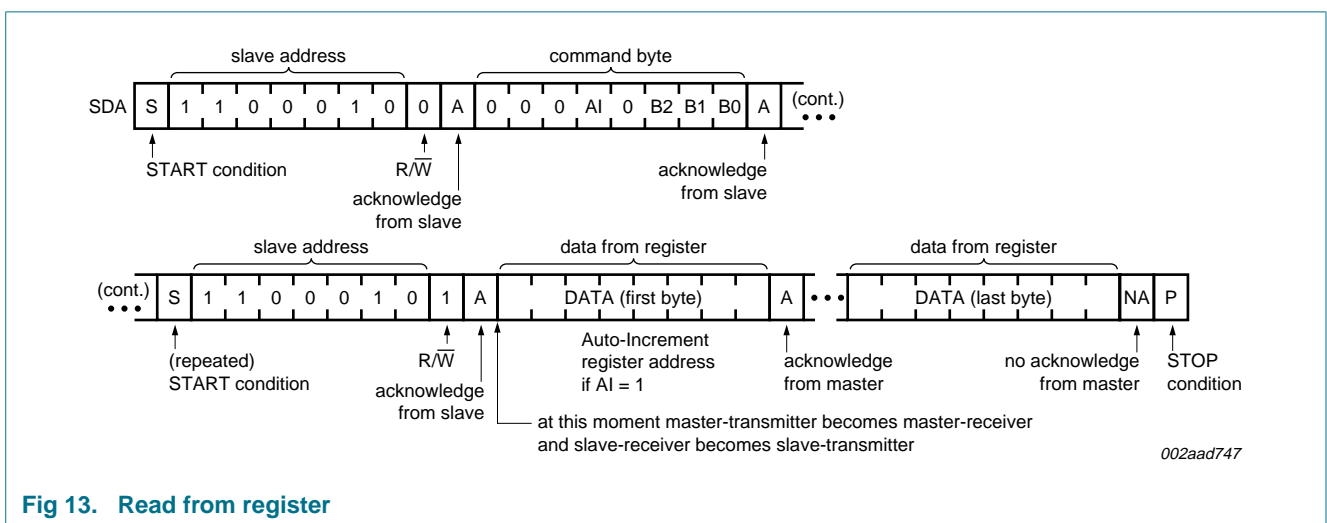
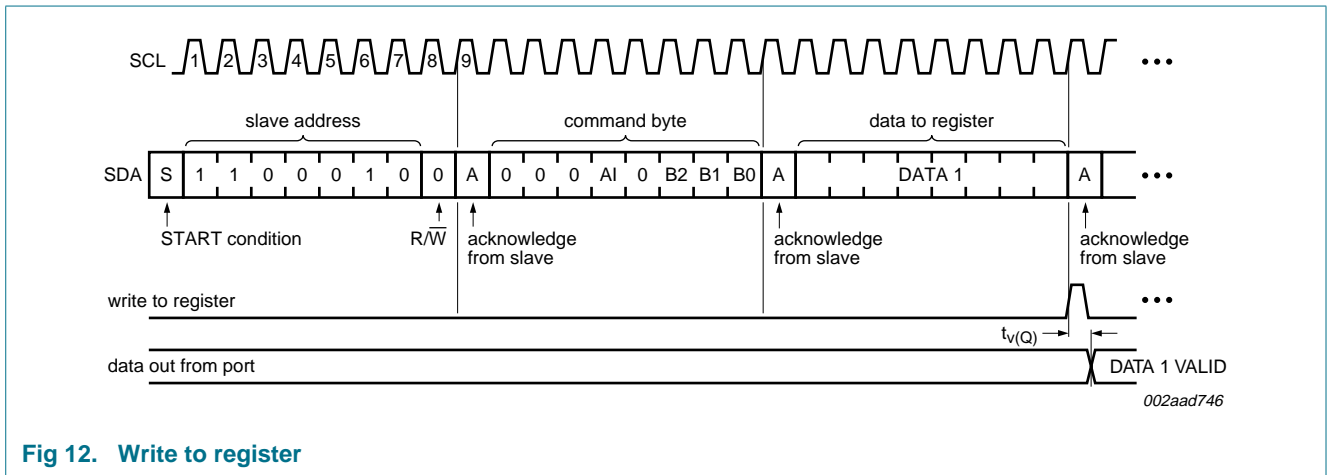

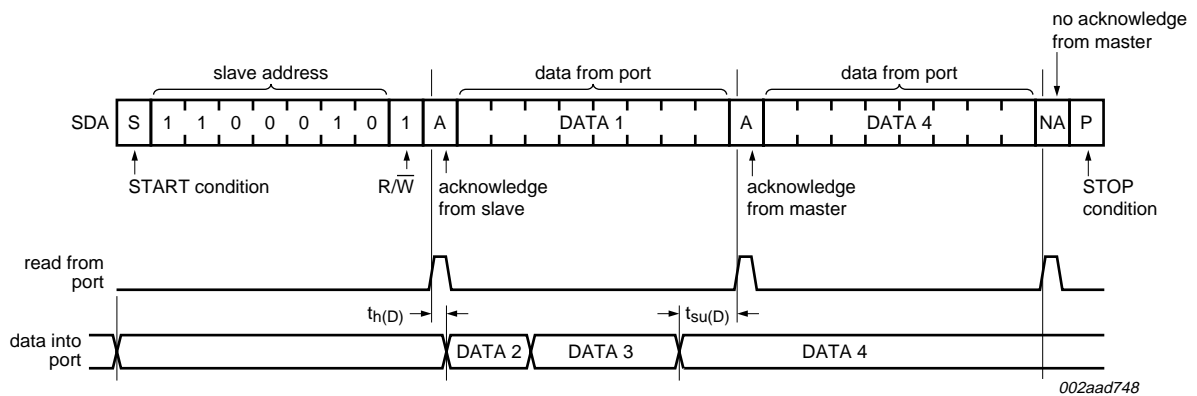

This figure assumes the command byte has previously been programmed with 00h.
PCA9553/01 shown.

Fig 14. Read input port register

9. Application design-in information

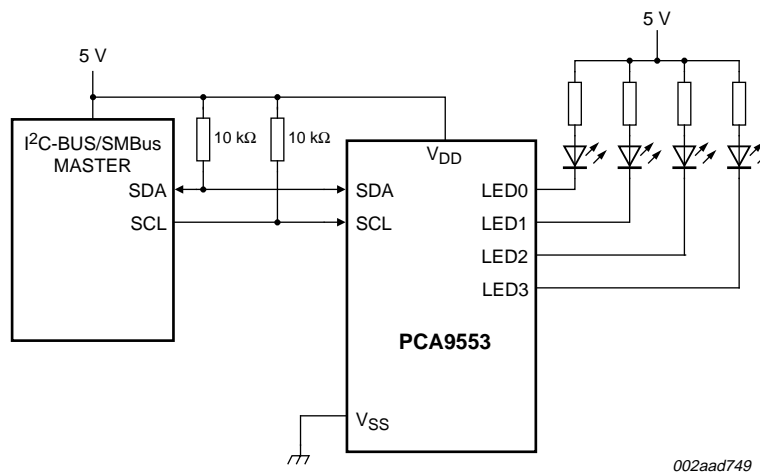
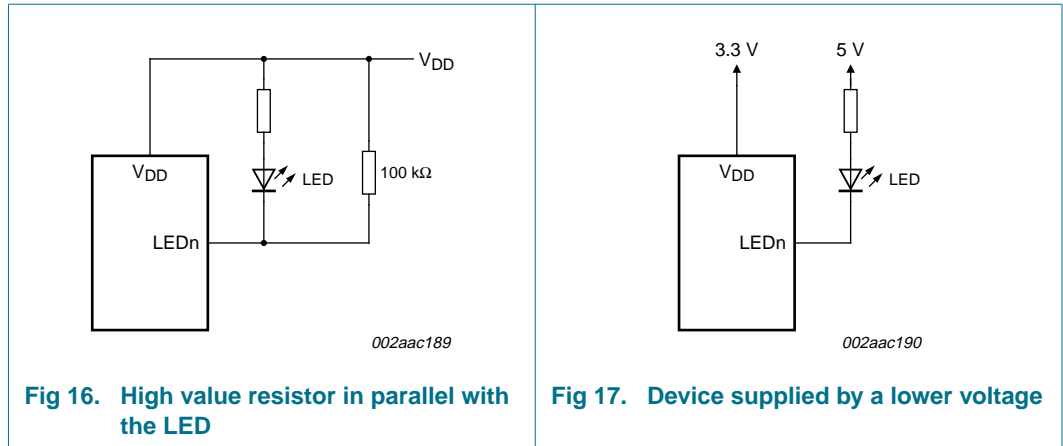

Fig 15. Typical application

9.1 Minimizing I_{DD} when the I/Os are used to control LEDs

When the I/Os are used to control LEDs, they are normally connected to V_{DD} through a resistor as shown in Figure 15. Since the LED acts as a diode, when the LED is off the I/O V_I is about 1.2 V less than V_{DD}. The supply current, I_{DD}, increases as V_I becomes lower than V_{DD} and is specified as ΔI_{DD} in Table 13 “Static characteristics”.

Designs needing to minimize current consumption, such as battery power applications, should consider maintaining the I/O pins greater than or equal to V_{DD} when the LED is off. Figure 16 shows a high value resistor in parallel with the LED. Figure 17 shows V_{DD} less than the LED supply voltage by at least 1.2 V. Both of these methods maintain the I/O V_I at or above V_{DD} and prevents additional supply current consumption when the LED is off.



9.2 Programming example

The following example shows how to set LED0 and LED1 off. It will then set LED2 to blink at 1 Hz, 50 % duty cycle. LED3 will be set to blink at 4 Hz, 25 % duty cycle. PCA9553/01 is used in this example.

Table 11. Programming PCA9553

Program sequence	I ² C-bus
START	S
PCA9553 address	C4h
PSC0 subaddress + Auto-Increment	11h
Set prescaler PSC0 to achieve a period of 1 second:	2Bh
$\text{Blink period} = 1 = \frac{\text{PSC0} + 1}{44}$	
PSC0 = 43	
Set PWM0 duty cycle to 50 %:	80h
$\frac{256 - \text{PWM0}}{256} = 0.5$	
PWM0 = 128	
Set prescaler PSC1 to achieve a period of 0.25 seconds:	0Ah
$\text{Blink period} = 0.25 = \frac{\text{PSC1} + 1}{44}$	
PSC1 = 10	
Set PWM1 output duty cycle to 25 %:	C0h
$\frac{256 - \text{PWM1}}{256} = 0.25$	
PWM1 = 192	
Set LED0 on, LED1 off, LED2 set to blink at PSC0, PWM0, LED3 set to blink at PSC1, PWM1	E4h
STOP	P

10. Limiting values

Table 12. Limiting values

In accordance with the Absolute Maximum Rating System (IEC 60134).

Symbol	Parameter	Conditions	Min	Max	Unit
V _{DD}	supply voltage		-0.5	+6.0	V
V _{I/O}	voltage on an input/output pin		V _{SS} - 0.5	5.5	V
I _{O(LEDn)}	output current on pin LEDn		-	±25	mA
I _{SS}	ground supply current		-	100	mA
P _{tot}	total power dissipation		-	400	mW
T _{stg}	storage temperature		-65	+150	°C
T _{amb}	ambient temperature	operating	-40	+85	°C

11. Static characteristics

Table 13. Static characteristics

$V_{DD} = 2.3\text{ V to }5.5\text{ V}$; $V_{SS} = 0\text{ V}$; $T_{amb} = -40\text{ °C to }+85\text{ °C}$; unless otherwise specified.

Symbol	Parameter	Conditions	Min	Typ ^[1]	Max	Unit
Supplies						
V_{DD}	supply voltage		2.3	-	5.5	V
I_{DD}	supply current	operating mode; $V_{DD} = 5.5\text{ V}$; no load; $V_I = V_{DD}$ or V_{SS} ; $f_{SCL} = 100\text{ kHz}$	-	350	500	μA
I_{stb}	standby current	Standby mode; $V_{DD} = 5.5\text{ V}$; no load; $V_I = V_{DD}$ or V_{SS} ; $f_{SCL} = 100\text{ kHz}$	-	1.9	3.0	μA
ΔI_{DD}	additional quiescent supply current	Standby mode; $V_{DD} = 5.5\text{ V}$; every LED I/O at $V_I = 4.3\text{ V}$; $f_{SCL} = 0\text{ kHz}$	-	-	325	μA
V_{POR}	power-on reset voltage	no load; $V_I = V_{DD}$ or V_{SS}	[2] -	1.7	2.2	V
Input SCL; input/output SDA						
V_{IL}	LOW-level input voltage		-0.5	-	+0.3 V_{DD}	V
V_{IH}	HIGH-level input voltage		0.7 V_{DD}	-	5.5	V
I_{OL}	LOW-level output current	$V_{OL} = 0.4\text{ V}$	3	6.5	-	mA
I_L	leakage current	$V_I = V_{DD} = V_{SS}$	-1	-	+1	μA
C_i	input capacitance	$V_I = V_{SS}$	-	3.7	5	pF
I/Os						
V_{IL}	LOW-level input voltage		-0.5	-	+0.8	V
V_{IH}	HIGH-level input voltage		2.0	-	5.5	V
I_{OL}	LOW-level output current	$V_{OL} = 0.4\text{ V}$				
		$V_{DD} = 2.3\text{ V}$	[3] 9	-	-	mA
		$V_{DD} = 3.0\text{ V}$	[3] 12	-	-	mA
		$V_{DD} = 5.0\text{ V}$	[3] 15	-	-	mA
		$V_{OL} = 0.7\text{ V}$				
		$V_{DD} = 2.3\text{ V}$	[3] 15	-	-	mA
		$V_{DD} = 3.0\text{ V}$	[3] 20	-	-	mA
$V_{DD} = 5.0\text{ V}$	[3] 25	-	-	mA		
I_{LI}	input leakage current	$V_{DD} = 3.6\text{ V}$; $V_I = 0\text{ V}$ or V_{DD}	-1	-	+1	μA
C_{iO}	input/output capacitance		-	2.1	5	pF

[1] Typical limits at $V_{DD} = 3.3\text{ V}$, $T_{amb} = 25\text{ °C}$.

[2] V_{DD} must be lowered to 0.2 V in order to reset part.

[3] Each I/O must be externally limited to a maximum of 25 mA and the device must be limited to a maximum current of 100 mA.

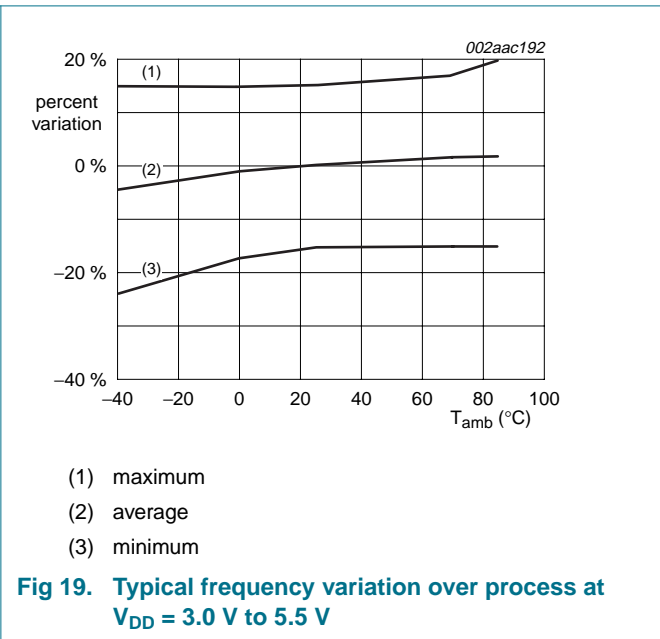
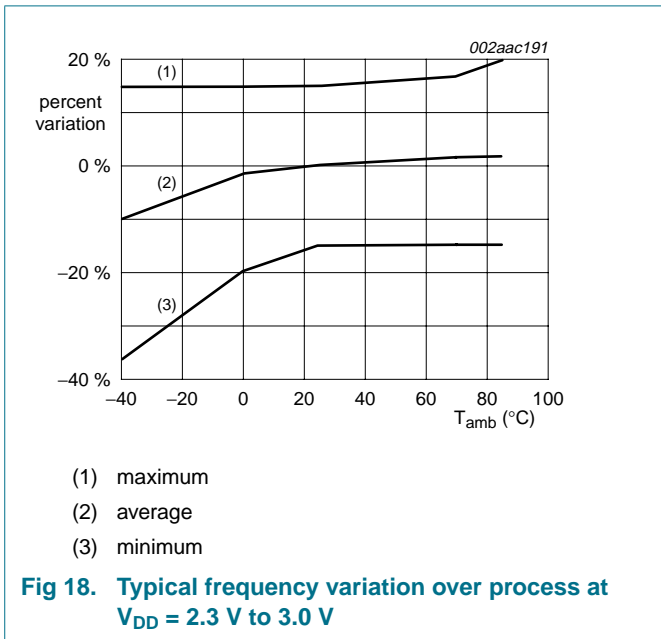

12. Dynamic characteristics

Table 14. Dynamic characteristics

Symbol	Parameter	Conditions	Standard-mode I ² C-bus		Fast-mode I ² C-bus		Unit
			Min	Max	Min	Max	
f _{SCL}	SCL clock frequency		0	100	0	400	kHz
t _{BUF}	bus free time between a STOP and START condition		4.7	-	1.3	-	μs
t _{HD;STA}	hold time (repeated) START condition		4.0	-	0.6	-	μs
t _{SU;STA}	set-up time for a repeated START condition		4.7	-	0.6	-	μs
t _{SU;STO}	set-up time for STOP condition		4.0	-	0.6	-	μs
t _{HD;DAT}	data hold time		0	-	0	-	ns
t _{VD;ACK}	data valid acknowledge time		[1]	600	-	600	ns
t _{VD;DAT}	data valid time	LOW-level	[2]	600	-	600	ns
		HIGH-level	[2]	1500	-	600	ns
t _{SU;DAT}	data set-up time		250	-	100	-	ns
t _{LOW}	LOW period of the SCL clock		4.7	-	1.3	-	μs
t _{HIGH}	HIGH period of the SCL clock		4.0	-	0.6	-	μs
t _r	rise time of both SDA and SCL signals		-	1000	20 + 0.1C _b [3]	300	ns
t _f	fall time of both SDA and SCL signals		-	300	20 + 0.1C _b [3]	300	ns
t _{SP}	pulse width of spikes that must be suppressed by the input filter		-	50	-	50	ns
Port timing							
t _{V(Q)}	data output valid time		-	200	-	200	ns
t _{SU(D)}	data input set-up time		100	-	100	-	ns
t _{H(D)}	data input hold time		1	-	1	-	μs

[1] t_{VD;ACK} = time for Acknowledgement signal from SCL LOW to SDA (out) LOW.

[2] t_{VD;DAT} = minimum time for SDA data output to be valid following SCL LOW.

[3] C_b = total capacitance of one bus line in pF.

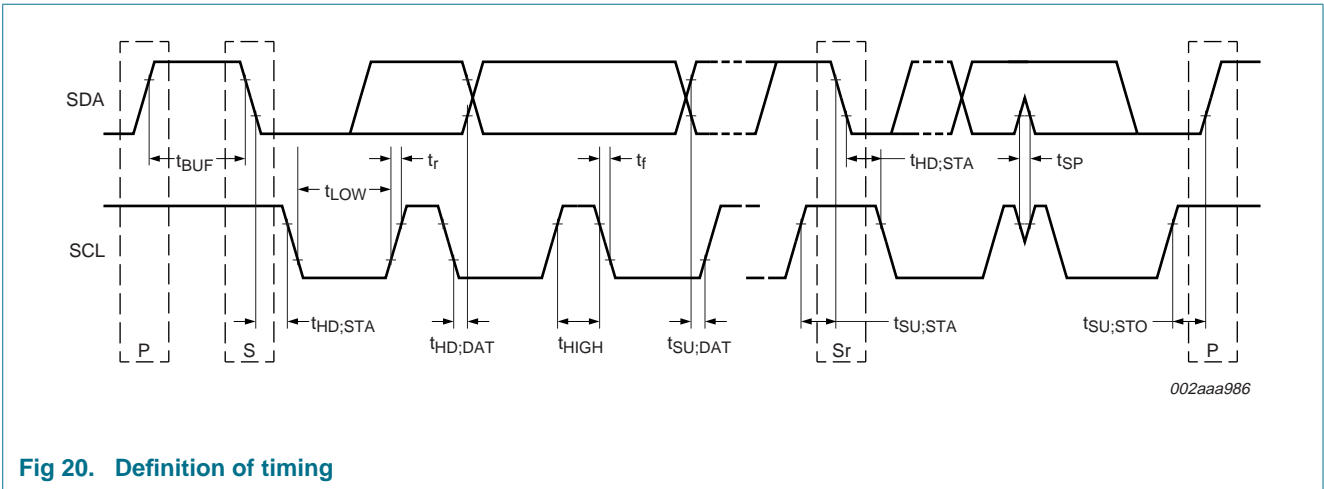

Fig 20. Definition of timing

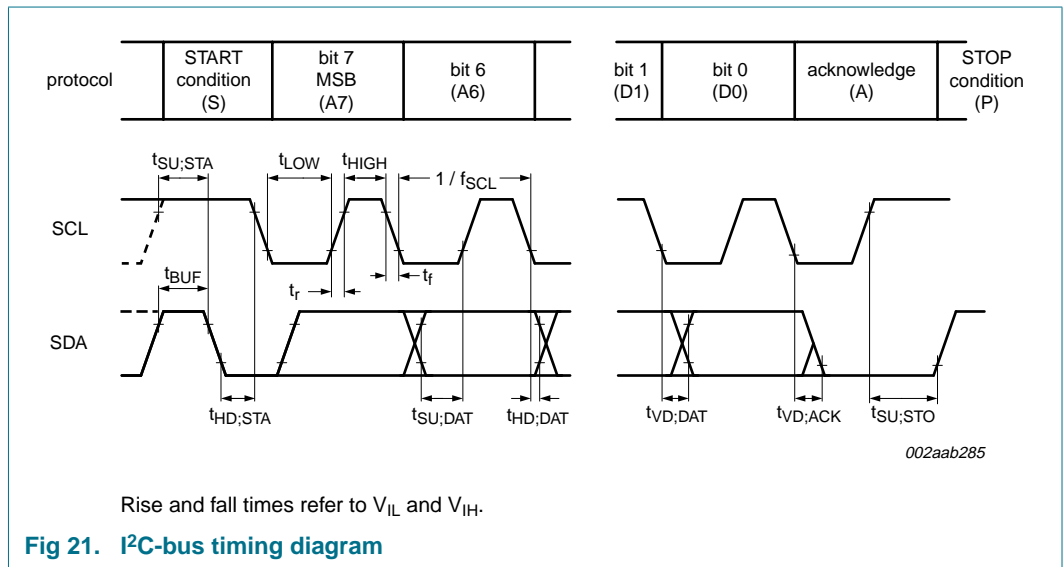

Fig 21. I²C-bus timing diagram

13. Test information

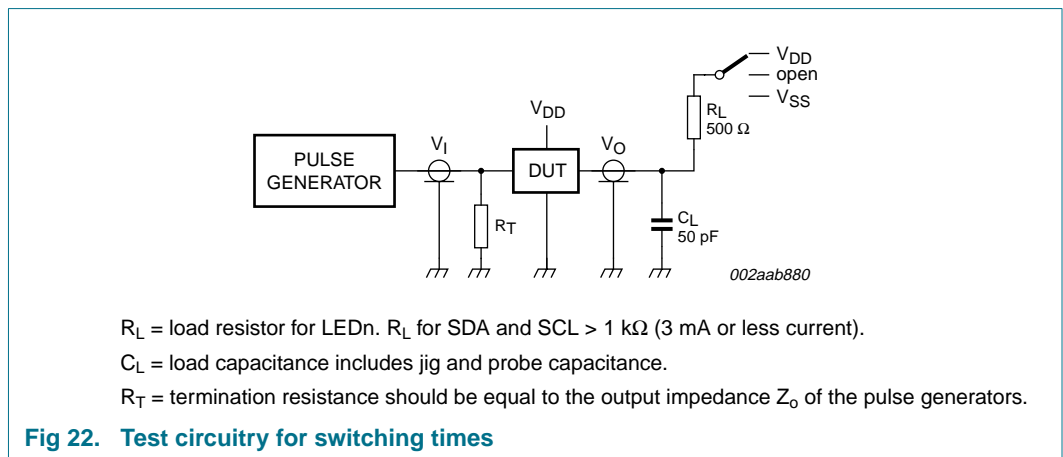

Fig 22. Test circuitry for switching times

14. Package outline

SO8: plastic small outline package; 8 leads; body width 3.9 mm

SOT96-1

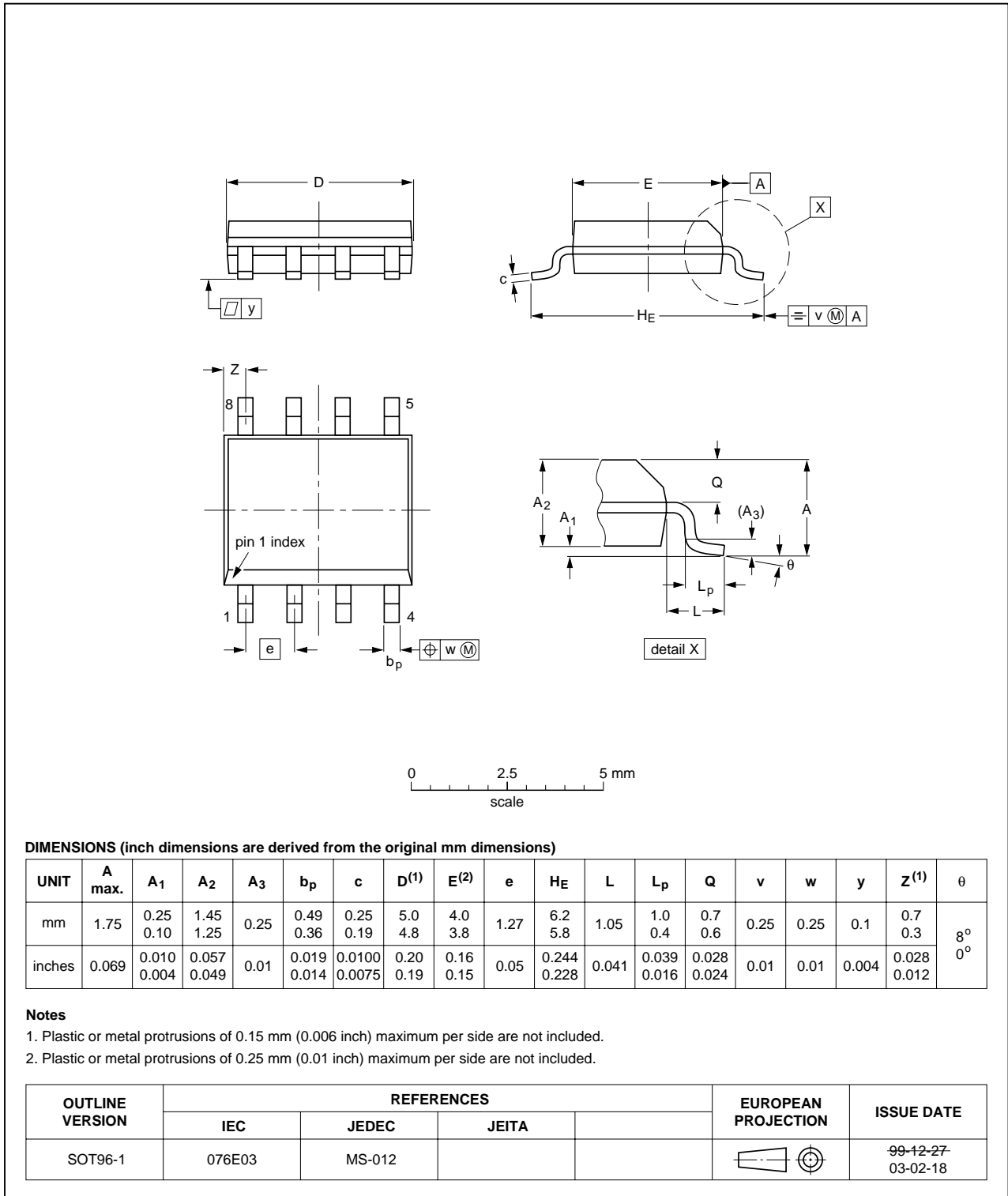

Fig 23. Package outline SOT96-1 (SO8)

TSSOP8: plastic thin shrink small outline package; 8 leads; body width 3 mm

SOT505-1

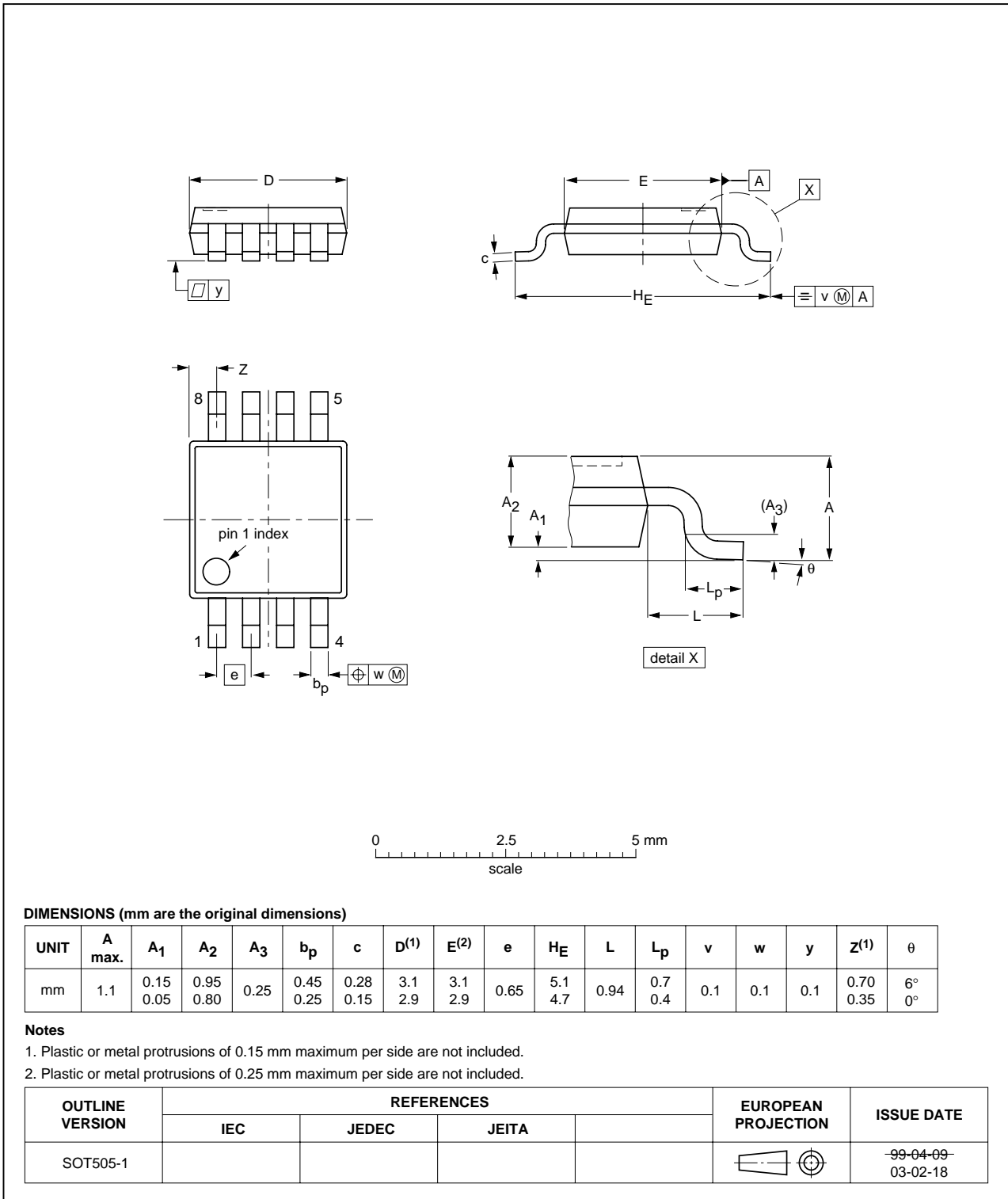

Fig 24. Package outline SOT505-1 (TSSOP8)

HVSON8: plastic thermal enhanced very thin small outline package; no leads;
8 terminals; body 3 x 3 x 0.85 mm

SOT908-1

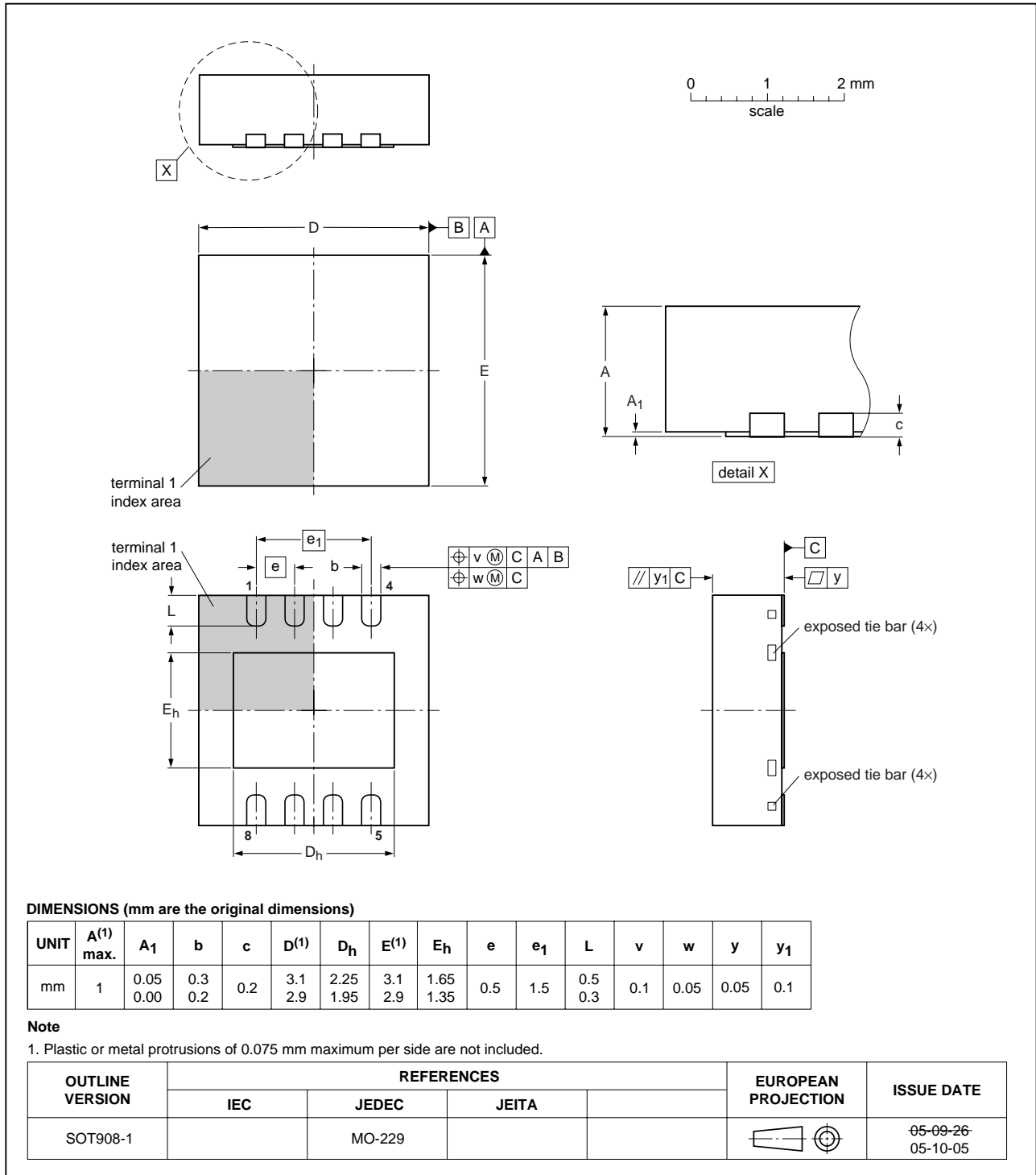

Fig 25. Package outline SOT908-1 (HVSON8)

15. Handling information

All input and output pins are protected against ElectroStatic Discharge (ESD) under normal handling. When handling ensure that the appropriate precautions are taken as described in *JESD625-A* or equivalent standards.

16. Soldering of SMD packages

This text provides a very brief insight into a complex technology. A more in-depth account of soldering ICs can be found in Application Note *AN10365 "Surface mount reflow soldering description"*.

16.1 Introduction to soldering

Soldering is one of the most common methods through which packages are attached to Printed Circuit Boards (PCBs), to form electrical circuits. The soldered joint provides both the mechanical and the electrical connection. There is no single soldering method that is ideal for all IC packages. Wave soldering is often preferred when through-hole and Surface Mount Devices (SMDs) are mixed on one printed wiring board; however, it is not suitable for fine pitch SMDs. Reflow soldering is ideal for the small pitches and high densities that come with increased miniaturization.

16.2 Wave and reflow soldering

Wave soldering is a joining technology in which the joints are made by solder coming from a standing wave of liquid solder. The wave soldering process is suitable for the following:

- Through-hole components
- Leaded or leadless SMDs, which are glued to the surface of the printed circuit board

Not all SMDs can be wave soldered. Packages with solder balls, and some leadless packages which have solder lands underneath the body, cannot be wave soldered. Also, leaded SMDs with leads having a pitch smaller than ~0.6 mm cannot be wave soldered, due to an increased probability of bridging.

The reflow soldering process involves applying solder paste to a board, followed by component placement and exposure to a temperature profile. Leaded packages, packages with solder balls, and leadless packages are all reflow solderable.

Key characteristics in both wave and reflow soldering are:

- Board specifications, including the board finish, solder masks and vias
- Package footprints, including solder thieves and orientation
- The moisture sensitivity level of the packages
- Package placement
- Inspection and repair
- Lead-free soldering versus SnPb soldering

16.3 Wave soldering

Key characteristics in wave soldering are:

- Process issues, such as application of adhesive and flux, clinching of leads, board transport, the solder wave parameters, and the time during which components are exposed to the wave
- Solder bath specifications, including temperature and impurities

16.4 Reflow soldering

Key characteristics in reflow soldering are:

- Lead-free versus SnPb soldering; note that a lead-free reflow process usually leads to higher minimum peak temperatures (see [Figure 26](#)) than a SnPb process, thus reducing the process window
- Solder paste printing issues including smearing, release, and adjusting the process window for a mix of large and small components on one board
- Reflow temperature profile; this profile includes preheat, reflow (in which the board is heated to the peak temperature) and cooling down. It is imperative that the peak temperature is high enough for the solder to make reliable solder joints (a solder paste characteristic). In addition, the peak temperature must be low enough that the packages and/or boards are not damaged. The peak temperature of the package depends on package thickness and volume and is classified in accordance with [Table 15](#) and [16](#)

Table 15. SnPb eutectic process (from J-STD-020C)

Package thickness (mm)	Package reflow temperature (°C)	
	Volume (mm ³)	
	< 350	≥ 350
< 2.5	235	220
≥ 2.5	220	220

Table 16. Lead-free process (from J-STD-020C)

Package thickness (mm)	Package reflow temperature (°C)		
	Volume (mm ³)		
	< 350	350 to 2000	> 2000
< 1.6	260	260	260
1.6 to 2.5	260	250	245
> 2.5	250	245	245

Moisture sensitivity precautions, as indicated on the packing, must be respected at all times.

Studies have shown that small packages reach higher temperatures during reflow soldering, see [Figure 26](#).

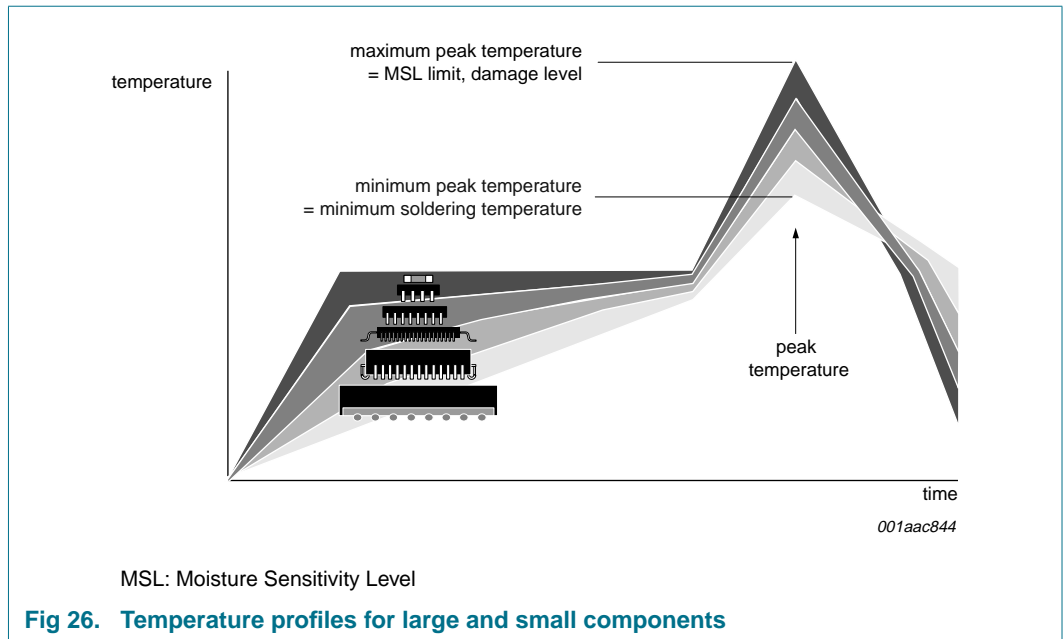

For further information on temperature profiles, refer to Application Note AN10365 “Surface mount reflow soldering description”.

17. Abbreviations

Table 17. Abbreviations

Acronym	Description
AI	Auto-Increment
CDM	Charged-Device Model
DSP	Digital Signal Processor
ESD	ElectroStatic Discharge
GPIO	General Purpose Input/Output
HBM	Human Body Model
I ² C-bus	Inter-Integrated Circuit bus
I/O	Input/Output
LED	Light Emitting Diode
MCU	MicroController Unit
MM	Machine Model
MPU	MicroProcessor Unit
PCB	Printed-Circuit Board
POR	Power-On Reset
PWM	Pulse Width Modulation
SMBus	System Management Bus

18. Revision history

Table 18. Revision history

Document ID	Release date	Data sheet status	Change notice	Supersedes
PCA9553_6	20081229	Product data sheet	-	PCA9553_5
Modifications:	<ul style="list-style-type: none"> • Table 2 "Marking codes": <ul style="list-style-type: none"> – marking code for type number PCA9553D/01 changed from "P9553/1" to "9553/1" – marking code for type number PCA9553D/02 changed from "P9553/2" to "9553/2" – marking code for type number PCA9553TK changed from "P53" to "P53/1" 			
PCA9553_5	20080422	Product data sheet	-	PCA9553_4
PCA9553_4	20060818	Product data sheet	-	PCA9553_3
PCA9553_3 (9397 750 13728)	20041001	Product data sheet	-	PCA9553_2
PCA9553_2 (9397 750 11464)	20030502	Product data	ECN 853-2397 29856 dated 2003 Apr 24	PCA9553_1
PCA9553_1 (9397 750 10859)	20021213	Product data	ECN 853-2397 29264 dated 2002 Dec 09	

19. Legal information

19.1 Data sheet status

Document status ^{[1][2]}	Product status ^[3]	Definition
Objective [short] data sheet	Development	This document contains data from the objective specification for product development.
Preliminary [short] data sheet	Qualification	This document contains data from the preliminary specification.
Product [short] data sheet	Production	This document contains the product specification.

[1] Please consult the most recently issued document before initiating or completing a design.

[2] The term 'short data sheet' is explained in section "Definitions".

[3] The product status of device(s) described in this document may have changed since this document was published and may differ in case of multiple devices. The latest product status information is available on the Internet at URL <http://www.nxp.com>.

19.2 Definitions

Draft — The document is a draft version only. The content is still under internal review and subject to formal approval, which may result in modifications or additions. NXP Semiconductors does not give any representations or warranties as to the accuracy or completeness of information included herein and shall have no liability for the consequences of use of such information.

Short data sheet — A short data sheet is an extract from a full data sheet with the same product type number(s) and title. A short data sheet is intended for quick reference only and should not be relied upon to contain detailed and full information. For detailed and full information see the relevant full data sheet, which is available on request via the local NXP Semiconductors sales office. In case of any inconsistency or conflict with the short data sheet, the full data sheet shall prevail.

19.3 Disclaimers

General — Information in this document is believed to be accurate and reliable. However, NXP Semiconductors does not give any representations or warranties, expressed or implied, as to the accuracy or completeness of such information and shall have no liability for the consequences of use of such information.

Right to make changes — NXP Semiconductors reserves the right to make changes to information published in this document, including without limitation specifications and product descriptions, at any time and without notice. This document supersedes and replaces all information supplied prior to the publication hereof.

Suitability for use — NXP Semiconductors products are not designed, authorized or warranted to be suitable for use in medical, military, aircraft, space or life support equipment, nor in applications where failure or malfunction of an NXP Semiconductors product can reasonably be expected

to result in personal injury, death or severe property or environmental damage. NXP Semiconductors accepts no liability for inclusion and/or use of NXP Semiconductors products in such equipment or applications and therefore such inclusion and/or use is at the customer's own risk.

Applications — Applications that are described herein for any of these products are for illustrative purposes only. NXP Semiconductors makes no representation or warranty that such applications will be suitable for the specified use without further testing or modification.

Limiting values — Stress above one or more limiting values (as defined in the Absolute Maximum Ratings System of IEC 60134) may cause permanent damage to the device. Limiting values are stress ratings only and operation of the device at these or any other conditions above those given in the Characteristics sections of this document is not implied. Exposure to limiting values for extended periods may affect device reliability.

Terms and conditions of sale — NXP Semiconductors products are sold subject to the general terms and conditions of commercial sale, as published at <http://www.nxp.com/profile/terms>, including those pertaining to warranty, intellectual property rights infringement and limitation of liability, unless explicitly otherwise agreed to in writing by NXP Semiconductors. In case of any inconsistency or conflict between information in this document and such terms and conditions, the latter will prevail.

No offer to sell or license — Nothing in this document may be interpreted or construed as an offer to sell products that is open for acceptance or the grant, conveyance or implication of any license under any copyrights, patents or other industrial or intellectual property rights.

19.4 Trademarks

Notice: All referenced brands, product names, service names and trademarks are the property of their respective owners.

I²C-bus — logo is a trademark of NXP B.V.

20. Contact information

For more information, please visit: <http://www.nxp.com>

For sales office addresses, please send an email to: salesaddresses@nxp.com

21. Contents

1	General description	1	19.1	Data sheet status	25
2	Features	1	19.2	Definitions	25
3	Ordering information	2	19.3	Disclaimers	25
4	Marking	2	19.4	Trademarks	25
5	Block diagram	3	20	Contact information	25
6	Pinning information	4	21	Contents	26
6.1	Pinning	4			
6.2	Pin description	4			
7	Functional description	5			
7.1	Device address	5			
7.2	Control register	5			
7.3	Register descriptions	6			
7.3.1	INPUT - Input register	6			
7.3.2	PSC0 - Frequency Prescaler 0	6			
7.3.3	PWM0 - Pulse Width Modulation 0	6			
7.3.4	PSC1 - Frequency Prescaler 1	7			
7.3.5	PWM1 - Pulse Width Modulation 1	7			
7.3.6	LS0 - LED selector register	7			
7.4	Pins used as general purpose I/Os	8			
7.5	Power-on reset	8			
8	Characteristics of the I²C-bus	8			
8.1	Bit transfer	8			
8.1.1	START and STOP conditions	8			
8.2	System configuration	9			
8.3	Acknowledge	9			
8.4	Bus transactions	10			
9	Application design-in information	11			
9.1	Minimizing I _{DD} when the I/Os are used to control LEDs	11			
9.2	Programming example	12			
10	Limiting values	13			
11	Static characteristics	14			
12	Dynamic characteristics	16			
13	Test information	17			
14	Package outline	18			
15	Handling information	21			
16	Soldering of SMD packages	21			
16.1	Introduction to soldering	21			
16.2	Wave and reflow soldering	21			
16.3	Wave soldering	21			
16.4	Reflow soldering	22			
17	Abbreviations	23			
18	Revision history	24			
19	Legal information	25			

Please be aware that important notices concerning this document and the product(s) described herein, have been included in section 'Legal information'.



© NXP B.V. 2008.

All rights reserved.

For more information, please visit: <http://www.nxp.com>
 For sales office addresses, please send an email to: salesaddresses@nxp.com

Date of release: 29 December 2008
 Document identifier: PCA9553_6



Looking for pricing, stock, or lifecycle information?

Click below to explore more details on WIN SOURCE:

 [View PCA9553DP/01,118 on WIN SOURCE](#)

 [NXP / Nexperia Information](#)

Optimize Your Supply Chain with WIN SOURCE Solutions

-  Global Sourcing Solution
-  Obsolete Management
-  Cost Control Management
-  Shortage Management
-  Alternative Solution
-  Excess Inventory Management