



**THE DATASHEET OF  
PCA9548ABS,118**





# PCA9548A

8-channel I<sup>2</sup>C-bus switch with reset

Rev. 5.1 — 1 October 2015

Product data sheet

## 1. General description

The PCA9548A is an octal bidirectional translating switch controlled via the I<sup>2</sup>C-bus. The SCL/SDA upstream pair fans out to eight downstream pairs, or channels. Any individual SCx/SDx channel or combination of channels can be selected, determined by the contents of the programmable control register.

An active LOW reset input allows the PCA9548A to recover from a situation where one of the downstream I<sup>2</sup>C-buses is stuck in a LOW state. Pulling the RESET pin LOW resets the I<sup>2</sup>C-bus state machine and causes all the channels to be deselected as does the internal Power-on reset function.

The pass gates of the switches are constructed such that the V<sub>DD</sub> pin can be used to limit the maximum high voltage which will be passed by the PCA9548A. This allows the use of different bus voltages on each pair, so that 1.8 V or 2.5 V or 3.3 V parts can communicate with 5 V parts without any additional protection. External pull-up resistors pull the bus up to the desired voltage level for each channel. All I/O pins are 6 V tolerant.

## 2. Features and benefits

- 1-of-8 bidirectional translating switches
- I<sup>2</sup>C-bus interface logic; compatible with SMBus standards
- Active LOW reset input
- Three address pins allowing up to eight devices on the I<sup>2</sup>C-bus
- Channel selection via I<sup>2</sup>C-bus, in any combination
- Power-up with all switch channels deselected
- Low R<sub>on</sub> switches
- Allows voltage level translation between 1.8 V, 2.5 V, 3.3 V and 5 V buses
- No glitch on power-up
- Supports hot insertion
- Low standby current
- Operating power supply voltage range of 2.3 V to 5.5 V
- 6 V tolerant inputs
- 0 Hz to 400 kHz clock frequency
- ESD protection exceeds 2000 V HBM per JESD22-A114 and 1000 V CDM per JESD22-C101
- Latch-up testing is done to JEDEC Standard JESD78 which exceeds 100 mA
- Three packages offered: SO24, TSSOP24, and HVQFN24



### 3. Ordering information

Table 1. Ordering information

Type number	Topside marking	Package		
		Name	Description	Version
PCA9548ABS	548A	HVQFN24	plastic thermal enhanced very thin quad flat package; no leads; 24 terminals; body 4 × 4 × 0.85 mm	SOT616-1
PCA9548AD	PCA9548AD	SO24	plastic small outline package; 24 leads; body width 7.5 mm	SOT137-1
PCA9548APW	PCA9548A	TSSOP24	plastic thin shrink small outline package; 24 leads; body width 4.4 mm	SOT355-1

#### 3.1 Ordering options

Table 2. Ordering options

Type number	Orderable part number	Package	Packing method	Minimum order quantity	Temperature
PCA9548ABS	PCA9548ABS,118	HVQFN24	Reel 13" Q1/T1 *Standard mark SMD	6000	T <sub>amb</sub> = -40 °C to +85 °C
	PCA9548ABSHP	HVQFN24	Reel 13" Q2/T3 *Standard mark SMD	6000	T <sub>amb</sub> = -40 °C to +85 °C
PCA9548AD	PCA9548AD,112	SO24	Standard marking IC's tube - DSC bulk pack	1200	T <sub>amb</sub> = -40 °C to +85 °C
	PCA9548AD,118	SO24	Reel 13" Q1/T1 *Standard mark SMD	1000	T <sub>amb</sub> = -40 °C to +85 °C
PCA9548APW	PCA9548APW,112	TSSOP24	Standard marking IC's tube - DSC bulk pack	1575	T <sub>amb</sub> = -40 °C to +85 °C
	PCA9548APW,118	TSSOP24	Reel 13" Q1/T1 *Standard mark SMD	2500	T <sub>amb</sub> = -40 °C to +85 °C

4. Block diagram

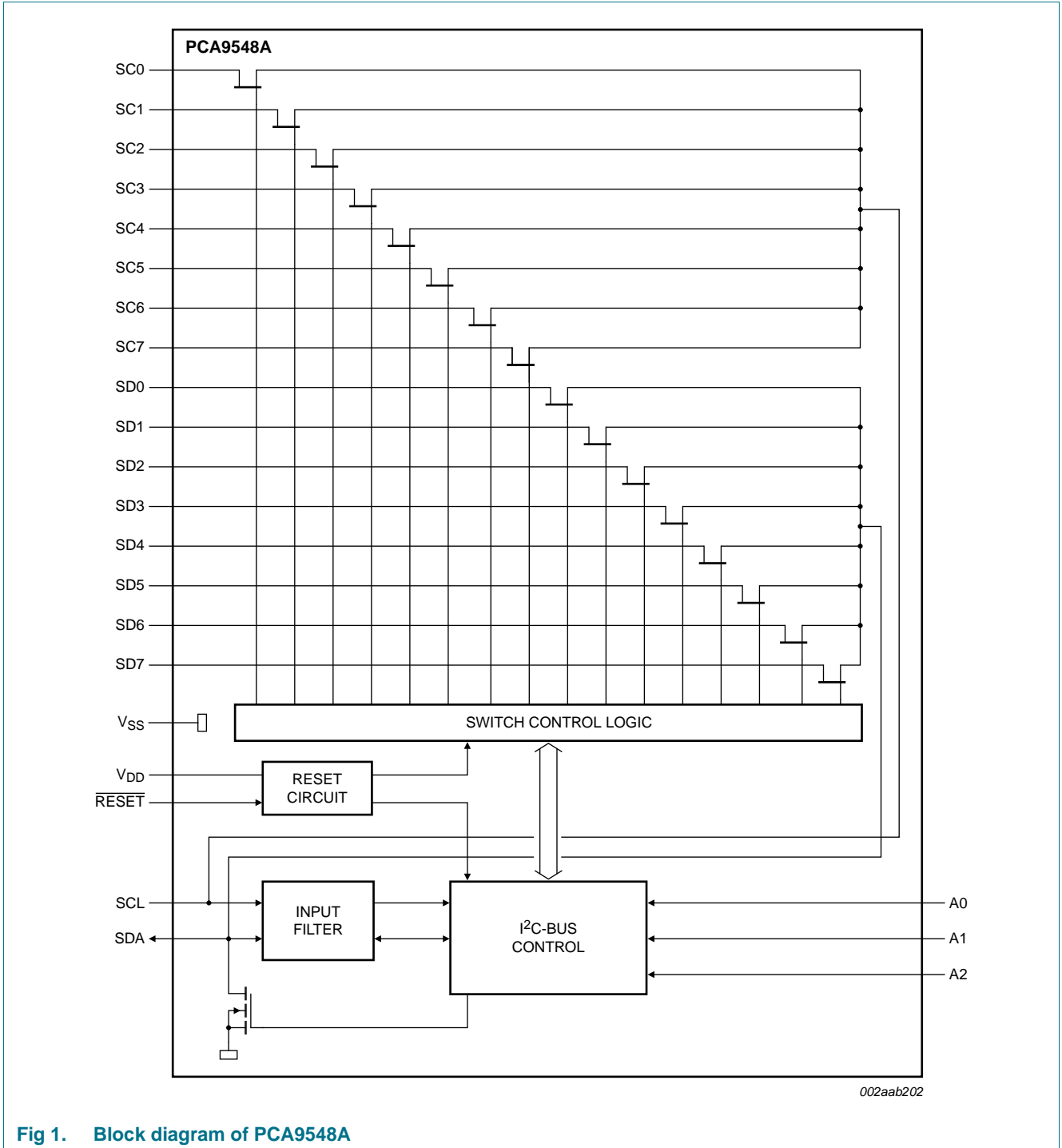

Fig 1. Block diagram of PCA9548A

5. Pinning information

5.1 Pinning

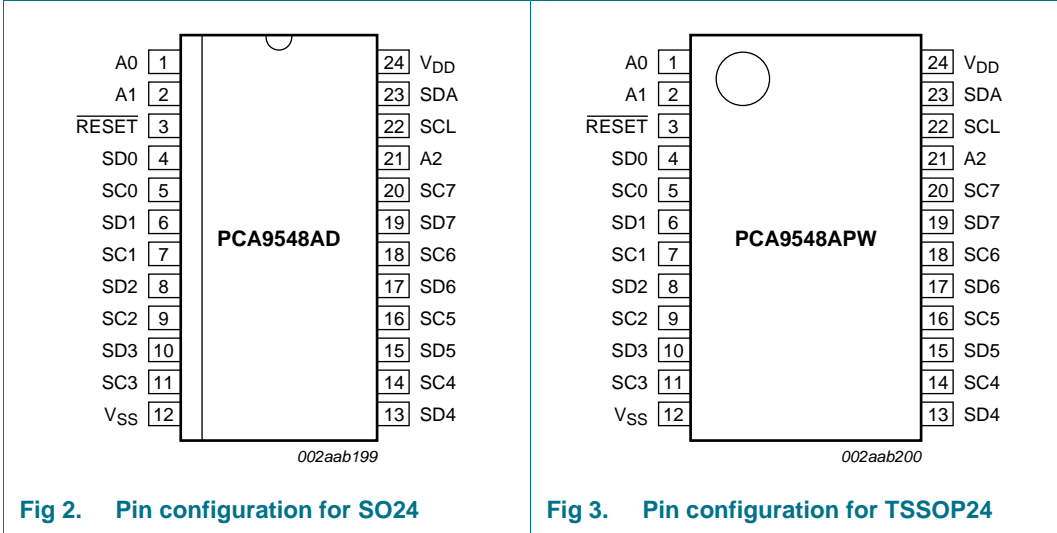

Fig 2. Pin configuration for SO24

Fig 3. Pin configuration for TSSOP24

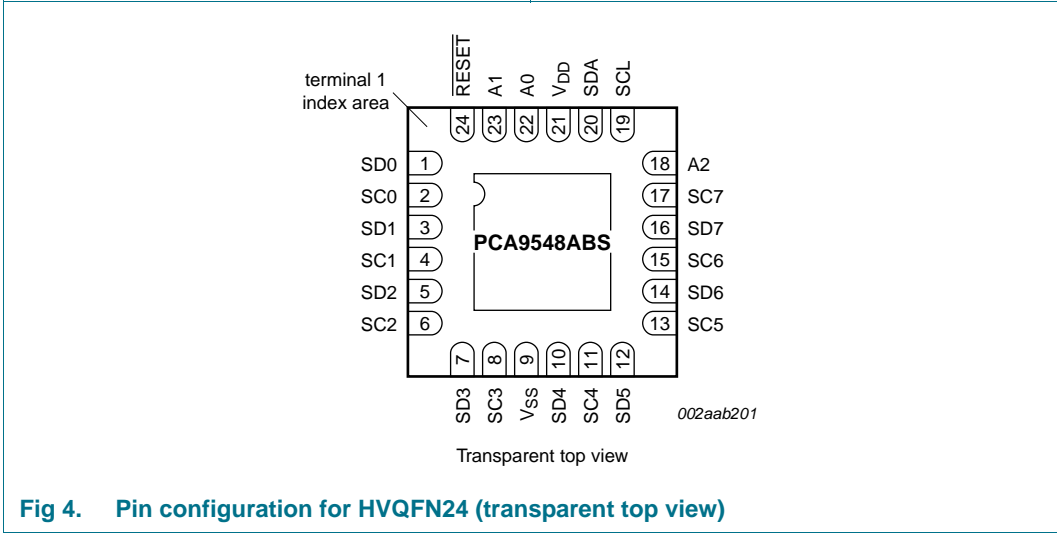

Fig 4. Pin configuration for HVQFN24 (transparent top view)

## 5.2 Pin description

Table 3. Pin description

Symbol	Pin		Description
	SO24, TSSOP24	HVQFN24	
A0	1	22	address input 0
A1	2	23	address input 1
$\overline{\text{RESET}}$	3	24	active LOW reset input
SD0	4	1	serial data 0
SC0	5	2	serial clock 0
SD1	6	3	serial data 1
SC1	7	4	serial clock 1
SD2	8	5	serial data 2
SC2	9	6	serial clock 2
SD3	10	7	serial data 3
SC3	11	8	serial clock 3
V <sub>SS</sub>	12	9 <sup>[1]</sup>	supply ground
SD4	13	10	serial data 4
SC4	14	11	serial clock 4
SD5	15	12	serial data 5
SC5	16	13	serial clock 5
SD6	17	14	serial data 6
SC6	18	15	serial clock 6
SD7	19	16	serial data 7
SC7	20	17	serial clock 7
A2	21	18	address input 2
SCL	22	19	serial clock line
SDA	23	20	serial data line
V <sub>DD</sub>	24	21	supply voltage

- [1] HVQFN24 package die supply ground is connected to both the V<sub>SS</sub> pin and the exposed center pad. The V<sub>SS</sub> pin must be connected to supply ground for proper device operation. For enhanced thermal, electrical, and board-level performance, the exposed pad needs to be soldered to the board using a corresponding thermal pad on the board, and for proper heat conduction through the board thermal vias need to be incorporated in the PCB in the thermal pad region.

## 6. Functional description

Refer to [Figure 1 “Block diagram of PCA9548A”](#).

### 6.1 Device address

Following a START condition, the bus master must output the address of the slave it is accessing. The address of the PCA9548A is shown in [Figure 5](#). To conserve power, no internal pull-up resistors are incorporated on the hardware selectable address pins and they must be pulled HIGH or LOW.

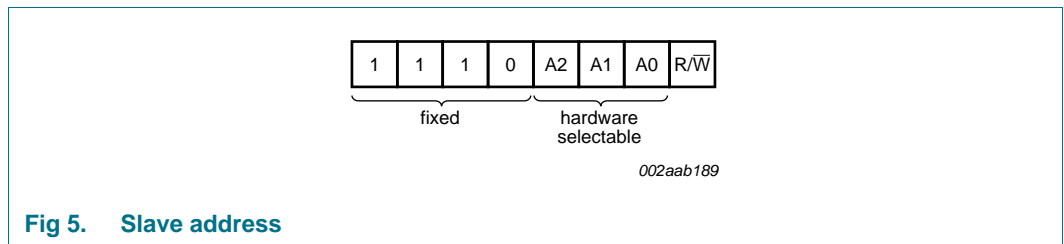

Fig 5. Slave address

The last bit of the slave address defines the operation to be performed. When set to logic 1 a read is selected, while a logic 0 selects a write operation.

### 6.2 Control register

Following the successful acknowledgement of the slave address, the bus master will send a byte to the PCA9548A, which will be stored in the control register. If multiple bytes are received by the PCA9548A, it will save the last byte received. This register can be written and read via the I<sup>2</sup>C-bus.

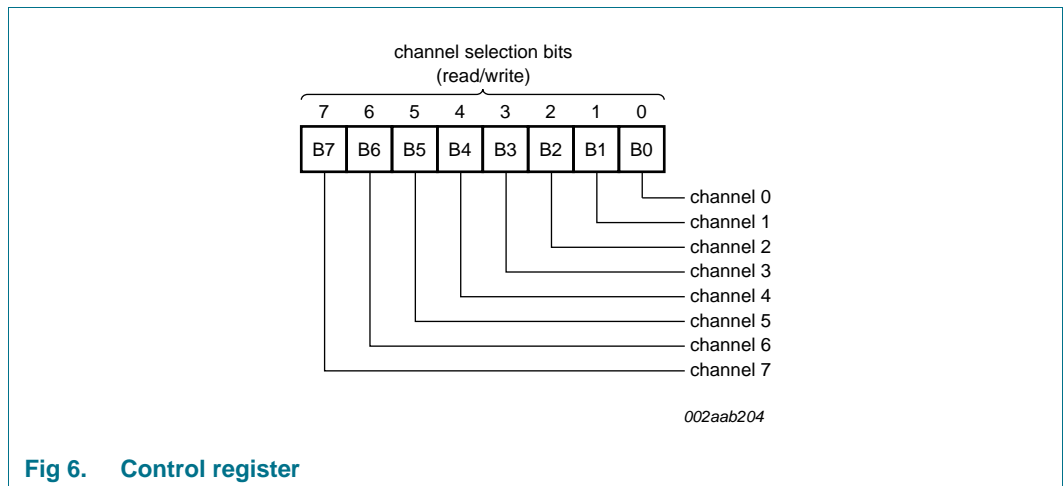

Fig 6. Control register

6.2.1 Control register definition

One or several SCx/SDx downstream pair, or channel, is selected by the contents of the control register. This register is written after the PCA9548A has been addressed. The contents of the control byte are used to determine which channel is to be selected. When a channel is selected, the channel will become active after a STOP condition has been placed on the I<sup>2</sup>C-bus. This ensures that all SCx/SDx lines will be in a HIGH state when the channel is made active, so that no false conditions are generated at the time of connection.

Table 4. Control register: Write—channel selection; Read—channel status

B7	B6	B5	B4	B3	B2	B1	B0	Command
X	X	X	X	X	X	X	0	channel 0 disabled
							1	channel 0 enabled
X	X	X	X	X	X	0	X	channel 1 disabled
								1
X	X	X	X	X	0	X	X	channel 2 disabled
								1
X	X	X	X	0	X	X	X	channel 3 disabled
								1
X	X	X	0	X	X	X	X	channel 4 disabled
								1
X	X	0	X	X	X	X	X	channel 5 disabled
								1
X	0	X	X	X	X	X	X	channel 6 disabled
								1
0	X	X	X	X	X	X	X	channel 7 disabled
								1

**Remark:** Multiple channels can be enabled at the same time. Example: B7 = 0, B6 = 1, B5 = 0, B4 = 0, B3 = 1, B2 = 1, B1 = 0, B0 = 0, means that channels 7, 5, 4, 1 and 0 are disabled and channels 6, 3, and 2 are enabled. Care should be taken not to exceed the maximum bus capacitance. Default condition is all zeroes.

6.3 RESET input

The RESET input is an active LOW signal which may be used to recover from a bus fault condition. By asserting this signal LOW for a minimum of  $t_{w(rst)L}$ , the PCA9548A will reset its register and I<sup>2</sup>C-bus state machine and will deselect all channels. The RESET input must be connected to V<sub>DD</sub> through a pull-up resistor.

6.4 Power-on reset

When power is applied to V<sub>DD</sub>, an internal Power-On Reset (POR) holds the PCA9548A in a reset condition until V<sub>DD</sub> has reached V<sub>POR</sub>. At this point, the reset condition is released and the PCA9548A register and I<sup>2</sup>C-bus state machine are initialized to their default states (all zeroes) causing all the channels to be deselected. Thereafter, V<sub>DD</sub> must be lowered below 0.2 V for at least 5 μs in order to reset the device.

6.5 Voltage translation

The pass gate transistors of the PCA9548A are constructed such that the V<sub>DD</sub> voltage can be used to limit the maximum voltage that will be passed from one I<sup>2</sup>C-bus to another.

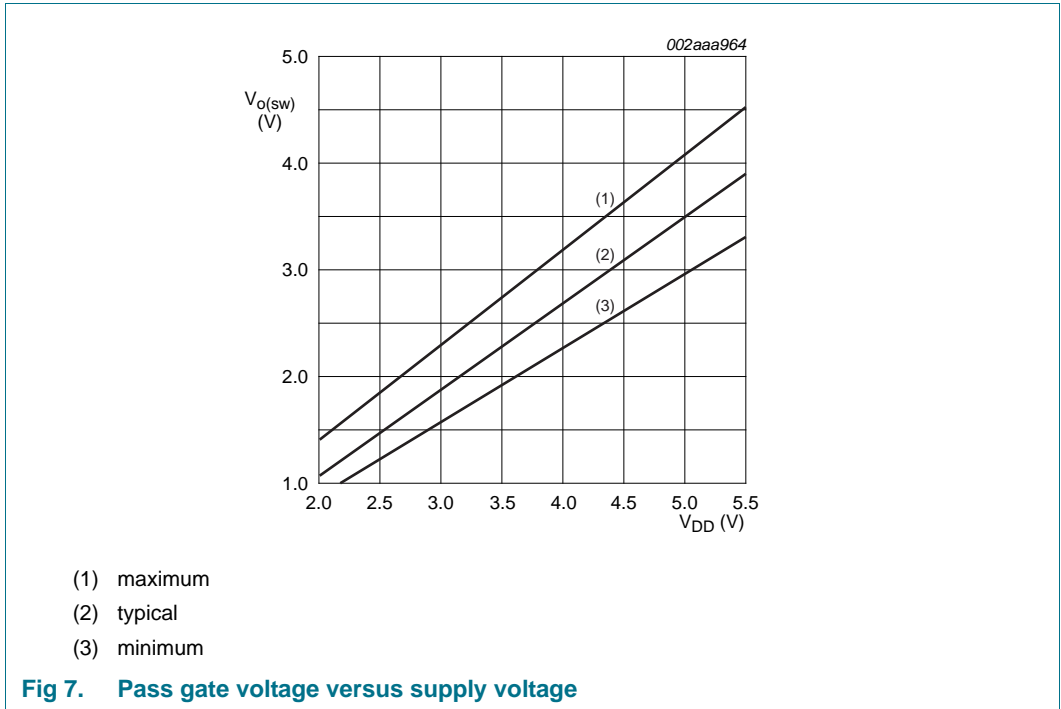

Figure 7 shows the voltage characteristics of the pass gate transistors (note that the PCA9548A is only tested at the points specified in Section 11 “Static characteristics” of this data sheet). In order for the PCA9548A to act as a voltage translator, the  $V_{O(SW)}$  voltage should be equal to, or lower than the lowest bus voltage. For example, if the main bus was running at 5 V, and the downstream buses were 3.3 V and 2.7 V, then  $V_{O(SW)}$  should be equal to or below 2.7 V to effectively clamp the downstream bus voltages. Looking at Figure 7, we see that  $V_{O(SW)(max)}$  will be at 2.7 V when the PCA9548A supply voltage is 3.5 V or lower, so the PCA9548A supply voltage could be set to 3.3 V. Pull-up resistors can then be used to bring the bus voltages to their appropriate levels (see Figure 14).

More Information can be found in Application Note AN262: PCA954X family of I<sup>2</sup>C/SMBus multiplexers and switches.

## 7. Characteristics of the I<sup>2</sup>C-bus

The I<sup>2</sup>C-bus is for 2-way, 2-line communication between different ICs or modules. The two lines are a serial data line (SDA) and a serial clock line (SCL). Both lines must be connected to a positive supply via a pull-up resistor when connected to the output stages of a device. Data transfer may be initiated only when the bus is not busy.

### 7.1 Bit transfer

One data bit is transferred during each clock pulse. The data on the SDA line must remain stable during the HIGH period of the clock pulse as changes in the data line at this time will be interpreted as control signals (see [Figure 8](#)).

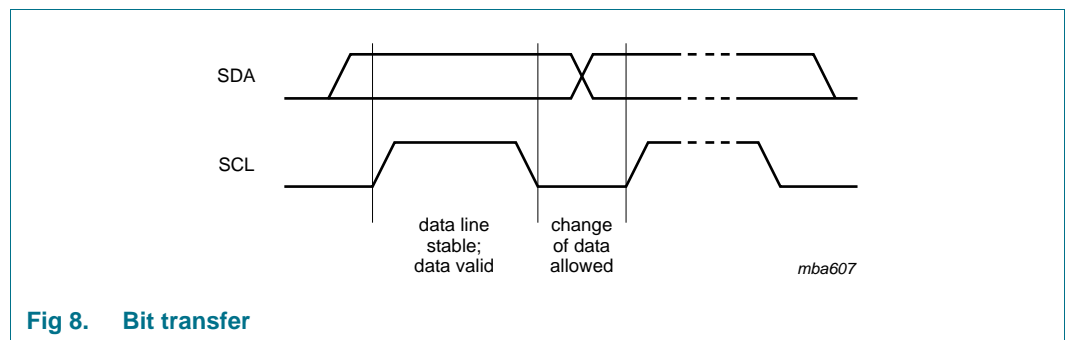

Fig 8. Bit transfer

### 7.2 START and STOP conditions

Both data and clock lines remain HIGH when the bus is not busy. A HIGH-to-LOW transition of the data line while the clock is HIGH is defined as the START condition (S). A LOW-to-HIGH transition of the data line while the clock is HIGH is defined as the STOP condition (P) (see [Figure 9](#)).

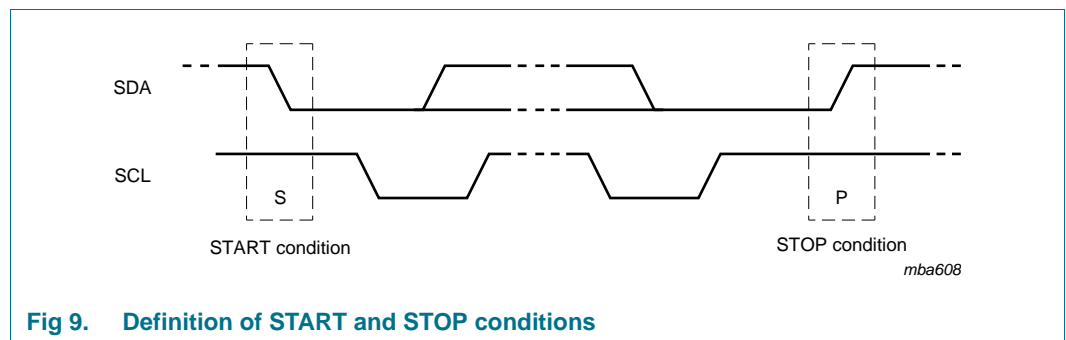

Fig 9. Definition of START and STOP conditions

### 7.3 System configuration

A device generating a message is a 'transmitter', a device receiving is the 'receiver'. The device that controls the message is the 'master' and the devices which are controlled by the master are the 'slaves' (see [Figure 10](#)).

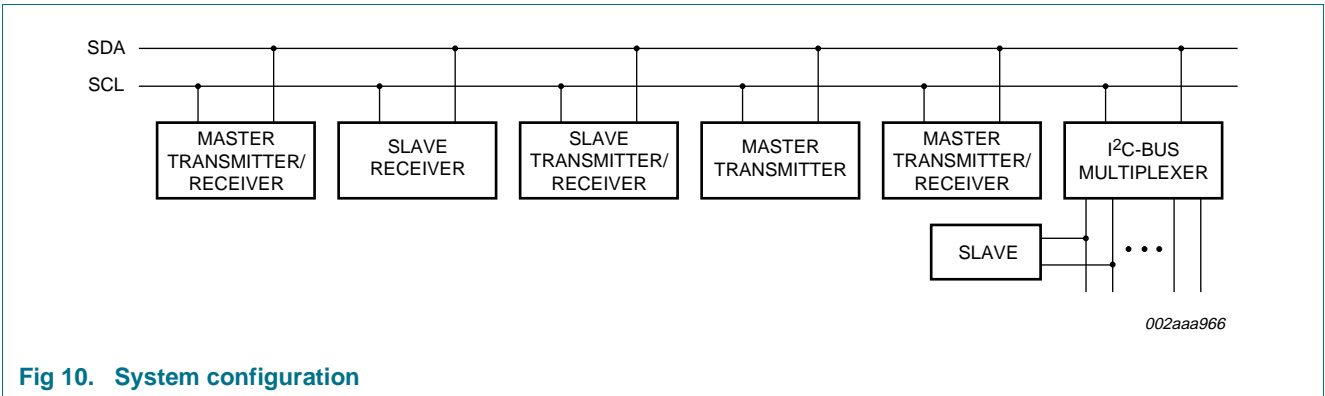

Fig 10. System configuration

### 7.4 Acknowledge

The number of data bytes transferred between the START and the STOP conditions from transmitter to receiver is not limited. Each byte of eight bits is followed by one acknowledge bit. The acknowledge bit is a HIGH level put on the bus by the transmitter, whereas the master generates an extra acknowledge related clock pulse.

A slave receiver which is addressed must generate an acknowledge after the reception of each byte. Also, a master must generate an acknowledge after the reception of each byte that has been clocked out of the slave transmitter. The device that acknowledges has to pull down the SDA line during the acknowledge clock pulse so that the SDA line is stable LOW during the HIGH period of the acknowledge related clock pulse; set-up and hold times must be taken into account.

A master receiver must signal an end of data to the transmitter by not generating an acknowledge on the last byte that has been clocked out of the slave. In this event, the transmitter must leave the data line HIGH to enable the master to generate a STOP condition.

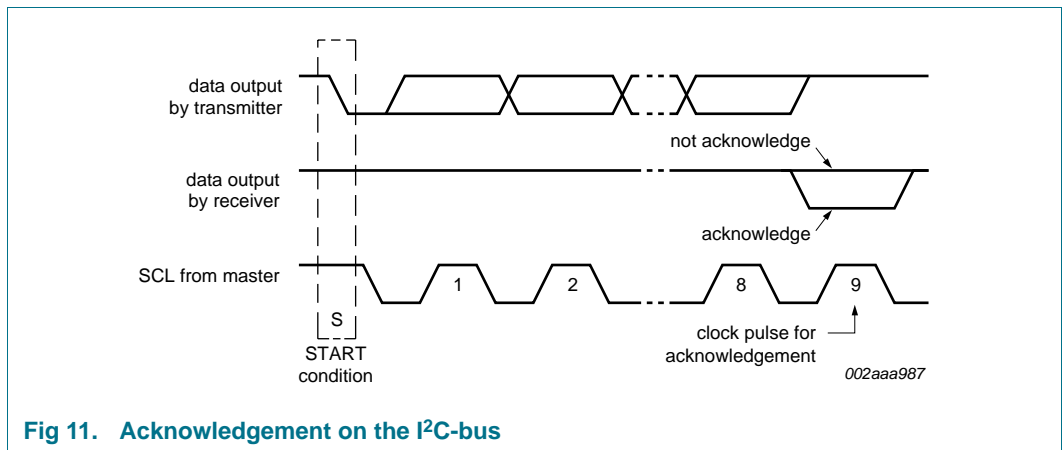

Fig 11. Acknowledgement on the I<sup>2</sup>C-bus

### 7.5 Bus transactions

Data is transmitted to the PCA9548A control register using the Write mode as shown in [Figure 12](#).

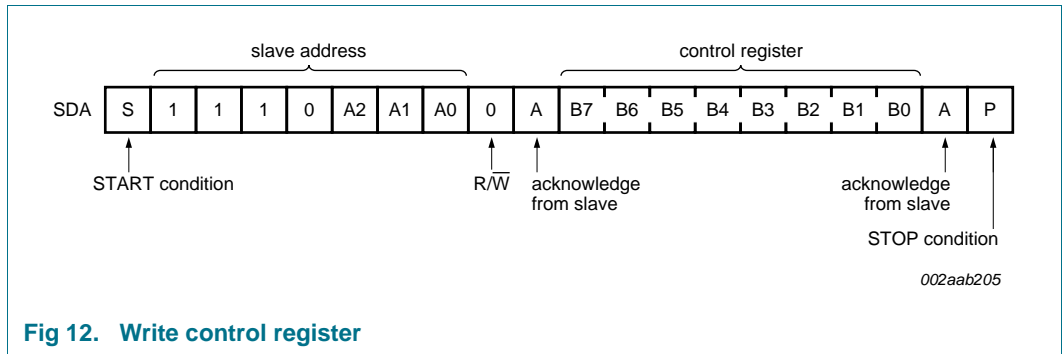

Fig 12. Write control register

Data is read from PCA9548A using the Read mode as shown in [Figure 13](#).

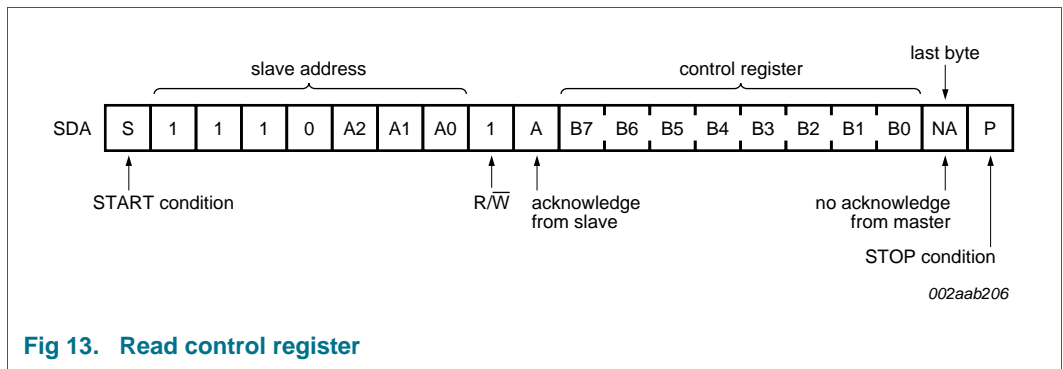

Fig 13. Read control register

8. Application design-in information

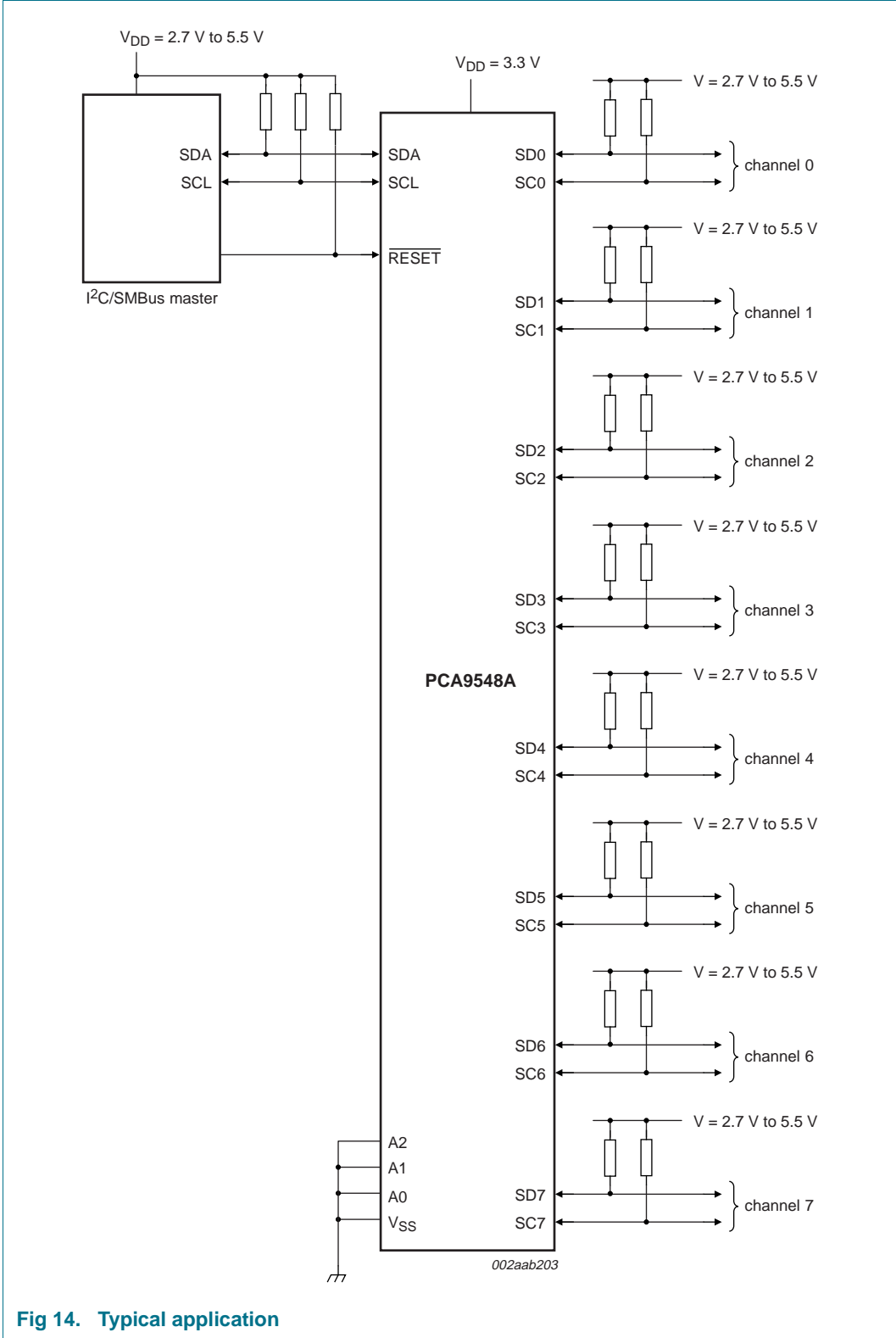

Fig 14. Typical application

## 9. Limiting values

**Table 5. Limiting values**

In accordance with the Absolute Maximum Rating System (IEC 60134). Voltages are referenced to  $V_{SS}$  (ground = 0 V).

Symbol	Parameter	Conditions	Min	Max	Unit
$V_{DD}$	supply voltage		-0.5	+7.0	V
$V_I$	input voltage		-0.5	+7.0	V
$I_I$	input current		-	±20	mA
$I_O$	output current		-	±25	mA
$I_{DD}$	supply current		-	±100	mA
$I_{SS}$	ground supply current		-	±100	mA
$P_{tot}$	total power dissipation		-	400	mW
$T_{j(max)}$	maximum junction temperature	[1]	-	125	°C
$T_{stg}$	storage temperature		-60	+150	°C
$T_{amb}$	ambient temperature	operating	-40	+85	°C

[1] The performance capability of a high-performance integrated circuit in conjunction with its thermal environment can create junction temperatures which are detrimental to reliability. The maximum junction temperature of this integrated circuit should not exceed 125 °C.

## 10. Thermal characteristics

**Table 6. Thermal characteristics**

Symbol	Parameter	Conditions	Typ	Unit
$R_{th(j-a)}$	thermal resistance from junction to ambient	HVQFN24 package	40	°C/W
		SO24 package	77	°C/W
		TSSOP24 package	128	°C/W

## 11. Static characteristics

**Table 7. Static characteristics at V<sub>DD</sub> = 2.3 V to 3.6 V**

V<sub>SS</sub> = 0 V; T<sub>amb</sub> = -40 °C to +85 °C; unless otherwise specified. See [Table 8 on page 15](#) for V<sub>DD</sub> = 4.5 V to 5.5 V.<sup>[1]</sup>

Symbol	Parameter	Conditions	Min	Typ	Max	Unit
<b>Supply</b>						
V <sub>DD</sub>	supply voltage		2.3	-	3.6	V
I <sub>DD</sub>	supply current	operating mode; V <sub>DD</sub> = 3.6 V; no load; V <sub>I</sub> = V <sub>DD</sub> or V <sub>SS</sub> ; f <sub>SCL</sub> = 100 kHz	-	30	50	μA
I <sub>stb</sub>	standby current	standby mode; V <sub>DD</sub> = 3.6 V; no load; V <sub>I</sub> = V <sub>DD</sub> or V <sub>SS</sub>	-	0.1	1	μA
V <sub>POR</sub>	power-on reset voltage	no load; V <sub>I</sub> = V <sub>DD</sub> or V <sub>SS</sub>	<sup>[2]</sup> -	1.6	2.1	V
<b>Input SCL; input/output SDA</b>						
V <sub>IL</sub>	LOW-level input voltage		-0.5	-	+0.3V <sub>DD</sub>	V
V <sub>IH</sub>	HIGH-level input voltage		0.7V <sub>DD</sub>	-	6	V
I <sub>OL</sub>	LOW-level output current	V <sub>OL</sub> = 0.4 V	3	6	-	mA
		V <sub>OL</sub> = 0.6 V	6	9	-	mA
I <sub>L</sub>	leakage current	V <sub>I</sub> = V <sub>DD</sub> or V <sub>SS</sub>	-1	-	+1	μA
C <sub>i</sub>	input capacitance	V <sub>I</sub> = V <sub>SS</sub>	-	15	21	pF
<b>Select inputs A0 to A2, RESET</b>						
V <sub>IL</sub>	LOW-level input voltage		-0.5	-	+0.3V <sub>DD</sub>	V
V <sub>IH</sub>	HIGH-level input voltage		0.7V <sub>DD</sub>	-	6	V
I <sub>LI</sub>	input leakage current	pin at V <sub>DD</sub> or V <sub>SS</sub>	-1	-	+1	μA
C <sub>i</sub>	input capacitance	V <sub>I</sub> = V <sub>SS</sub>	-	2	5	pF
<b>Pass gate</b>						
R <sub>on</sub>	ON-state resistance	V <sub>DD</sub> = 3.0 V to 3.6 V; V <sub>O</sub> = 0.4 V; I <sub>O</sub> = 15 mA	5	11	30	Ω
		V <sub>DD</sub> = 2.3 V to 2.7 V; V <sub>O</sub> = 0.4 V; I <sub>O</sub> = 10 mA	7	16	55	Ω
V <sub>O(sw)</sub>	switch output voltage	V <sub>i(sw)</sub> = V <sub>DD</sub> = 3.3 V; I <sub>o(sw)</sub> = -100 μA	-	1.9	-	V
		V <sub>i(sw)</sub> = V <sub>DD</sub> = 3.0 V to 3.6 V; I <sub>o(sw)</sub> = -100 μA	1.6	-	2.8	V
		V <sub>i(sw)</sub> = V <sub>DD</sub> = 2.5 V; I <sub>o(sw)</sub> = -100 μA	-	1.5	-	V
		V <sub>i(sw)</sub> = V <sub>DD</sub> = 2.3 V to 2.7 V; I <sub>o(sw)</sub> = -100 μA	1.1	-	2.0	V
I <sub>L</sub>	leakage current	V <sub>I</sub> = V <sub>DD</sub> or V <sub>SS</sub>	-1	-	+1	μA
C <sub>io</sub>	input/output capacitance	V <sub>I</sub> = V <sub>SS</sub>	-	3	5	pF

[1] For operation between published voltage ranges, refer to the worst-case parameter in both ranges.

[2] V<sub>DD</sub> must be lowered to 0.2 V for at least 5 μs in order to reset part.

**Table 8. Static characteristics at V<sub>DD</sub> = 4.5 V to 5.5 V**V<sub>SS</sub> = 0 V; T<sub>amb</sub> = -40 °C to +85 °C; unless otherwise specified. See [Table 7 on page 14](#) for V<sub>DD</sub> = 2.3 V to 3.6 V [\[1\]](#)

Symbol	Parameter	Conditions	Min	Typ	Max	Unit
<b>Supply</b>						
V <sub>DD</sub>	supply voltage		4.5	-	5.5	V
I <sub>DD</sub>	supply current	operating mode; V <sub>DD</sub> = 5.5 V; no load; V <sub>I</sub> = V <sub>DD</sub> or V <sub>SS</sub> ; f <sub>SCL</sub> = 100 kHz	-	65	100	μA
I <sub>stb</sub>	standby current	standby mode; V <sub>DD</sub> = 5.5 V; no load; V <sub>I</sub> = V <sub>DD</sub> or V <sub>SS</sub>	-	0.2	1	μA
V <sub>POR</sub>	power-on reset voltage	no load; V <sub>I</sub> = V <sub>DD</sub> or V <sub>SS</sub>	<a href="#">[2]</a> -	1.7	2.1	V
<b>Input SCL; input/output SDA</b>						
V <sub>IL</sub>	LOW-level input voltage		-0.5	-	+0.3V <sub>DD</sub>	V
V <sub>IH</sub>	HIGH-level input voltage		0.7V <sub>DD</sub>	-	6	V
I <sub>OL</sub>	LOW-level output current	V <sub>OL</sub> = 0.4 V	3	-	-	mA
		V <sub>OL</sub> = 0.6 V	6	-	-	mA
I <sub>IL</sub>	LOW-level input current	V <sub>I</sub> = V <sub>SS</sub>	-1	-	+1	μA
I <sub>IH</sub>	HIGH-level input current	V <sub>I</sub> = V <sub>DD</sub>	-1	-	+1	μA
C <sub>i</sub>	input capacitance	V <sub>I</sub> = V <sub>SS</sub>	-	15	21	pF
<b>Select inputs A0 to A2, RESET</b>						
V <sub>IL</sub>	LOW-level input voltage		-0.5	-	+0.3V <sub>DD</sub>	V
V <sub>IH</sub>	HIGH-level input voltage		0.7V <sub>DD</sub>	-	6	V
I <sub>LI</sub>	input leakage current	pin at V <sub>DD</sub> or V <sub>SS</sub>	-1	-	+1	μA
C <sub>i</sub>	input capacitance	V <sub>I</sub> = V <sub>SS</sub>	-	2	5	pF
<b>Pass gate</b>						
R <sub>on</sub>	ON-state resistance	V <sub>DD</sub> = 4.5 V to 5.5 V; V <sub>O</sub> = 0.4 V; I <sub>O</sub> = 15 mA	4	9	24	Ω
V <sub>O(sw)</sub>	switch output voltage	V <sub>i(sw)</sub> = V <sub>DD</sub> = 5.0 V; I <sub>o(sw)</sub> = -100 μA	-	3.6	-	V
		V <sub>i(sw)</sub> = V <sub>DD</sub> = 4.5 V to 5.5 V; I <sub>o(sw)</sub> = -100 μA	2.6	-	4.5	V
I <sub>L</sub>	leakage current	V <sub>I</sub> = V <sub>DD</sub> or V <sub>SS</sub>	-1	-	+1	μA
C <sub>io</sub>	input/output capacitance	V <sub>I</sub> = V <sub>SS</sub>	-	3	5	pF

[1] For operation between published voltage ranges, refer to the worst-case parameter in both ranges.

[2] V<sub>DD</sub> must be lowered to 0.2 V for at least 5 μs in order to reset part.

## 12. Dynamic characteristics

**Table 9. Dynamic characteristics**

Symbol	Parameter	Conditions	Standard-mode I <sup>2</sup> C-bus		Fast-mode I <sup>2</sup> C-bus		Unit	
			Min	Max	Min	Max		
t <sub>PD</sub>	propagation delay	from SDA to SDx, or SCL to SCx	-	0.3 <sup>[1]</sup>	-	0.3 <sup>[1]</sup>	ns	
f <sub>SCL</sub>	SCL clock frequency		0	100	0	400	kHz	
t <sub>BUF</sub>	bus free time between a STOP and START condition		4.7	-	1.3	-	μs	
t <sub>HD;STA</sub>	hold time (repeated) START condition	<sup>[2]</sup>	4.0	-	0.6	-	μs	
t <sub>LOW</sub>	LOW period of the SCL clock		4.7	-	1.3	-	μs	
t <sub>HIGH</sub>	HIGH period of the SCL clock		4.0	-	0.6	-	μs	
t <sub>SU;STA</sub>	set-up time for a repeated START condition		4.7	-	0.6	-	μs	
t <sub>SU;STO</sub>	set-up time for STOP condition		4.0	-	0.6	-	μs	
t <sub>HD;DAT</sub>	data hold time		0 <sup>[3]</sup>	<sup>[4]</sup>	0 <sup>[3]</sup>	<sup>[4]</sup>	μs	
t <sub>SU;DAT</sub>	data set-up time		250	-	100	-	ns	
t <sub>r</sub>	rise time of both SDA and SCL signals		-	1000	20 + 0.1C <sub>b</sub> <sup>[5]</sup>	300	ns	
t <sub>f</sub>	fall time of both SDA and SCL signals		-	300	20 + 0.1C <sub>b</sub> <sup>[5]</sup>	300	ns	
C <sub>b</sub>	capacitive load for each bus line		-	400	-	400	pF	
t <sub>SP</sub>	pulse width of spikes that must be suppressed by the input filter		-	50	-	50	ns	
t <sub>VD;DAT</sub>	data valid time	HIGH-to-LOW	<sup>[6]</sup>	-	1	-	1	μs
		LOW-to-HIGH	<sup>[6]</sup>	-	0.6	-	0.6	μs
t <sub>VD;ACK</sub>	data valid acknowledge time		-	1	-	1	μs	
<b>RESET</b>								
t <sub>w(rst)L</sub>	LOW-level reset time		4	-	4	-	ns	
t <sub>rst</sub>	reset time	SDA clear	-	500	-	500	ns	
t <sub>REC;STA</sub>	recovery time to START condition		0	-	0	-	ns	

[1] Pass gate propagation delay is calculated from the 20 Ω typical R<sub>on</sub> and the 15 pF load capacitance.

[2] After this period, the first clock pulse is generated.

[3] A device must internally provide a hold time of at least 300 ns for the SDA signal (referred to the V<sub>IH(min)</sub> of the SCL signal) in order to bridge the undefined region of the falling edge of SCL.

[4] The maximum t<sub>HD;DAT</sub> could be 3.45 μs and 0.9 μs for Standard-mode and Fast-mode, but must be less than the maximum of t<sub>VD;DAT</sub> or t<sub>VD;ACK</sub> by a transition time. This maximum must only be met if the device does not stretch the LOW period (t<sub>LOW</sub>) of the SCL signal. If the clock stretches the SCL, the data must be valid by the set-up time before it releases the clock.

[5] C<sub>b</sub> = total capacitance of one bus line in pF.

[6] Measurements taken with 1 kΩ pull-up resistor and 50 pF load.

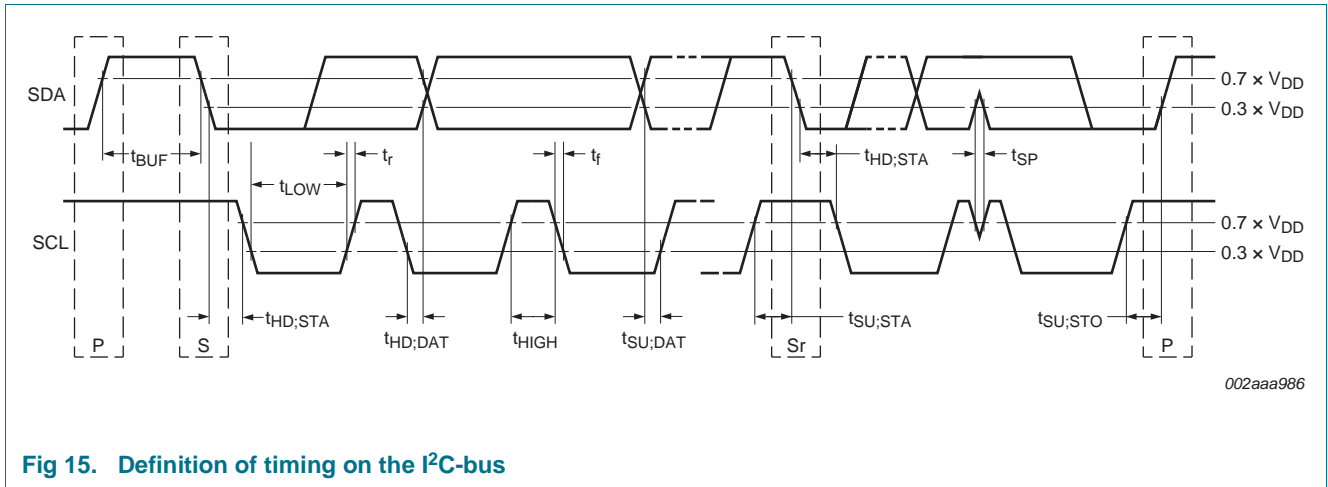

Fig 15. Definition of timing on the I<sup>2</sup>C-bus

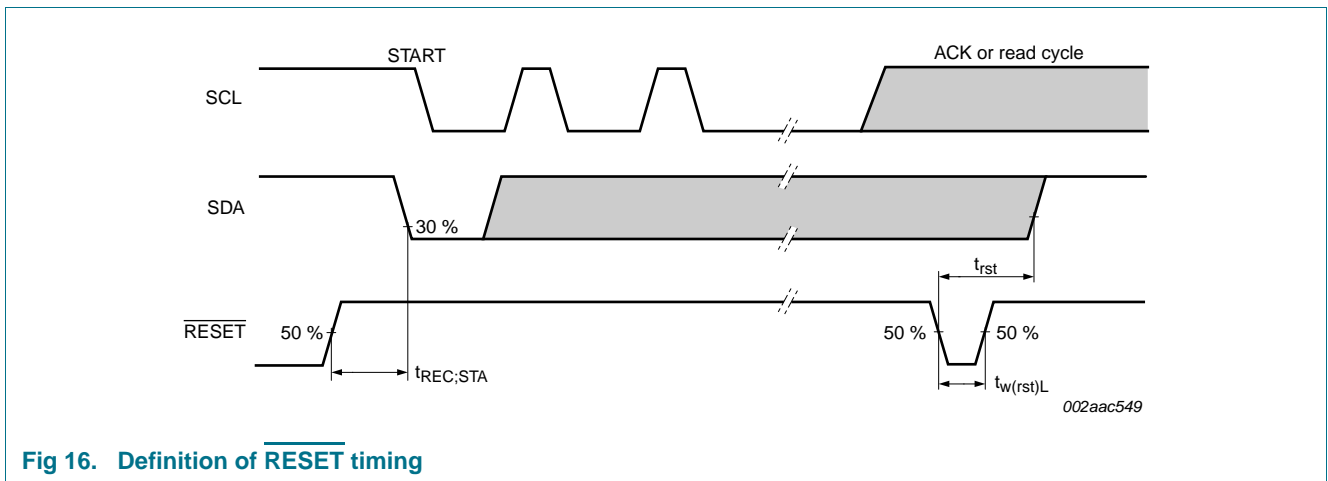

Fig 16. Definition of RESET timing

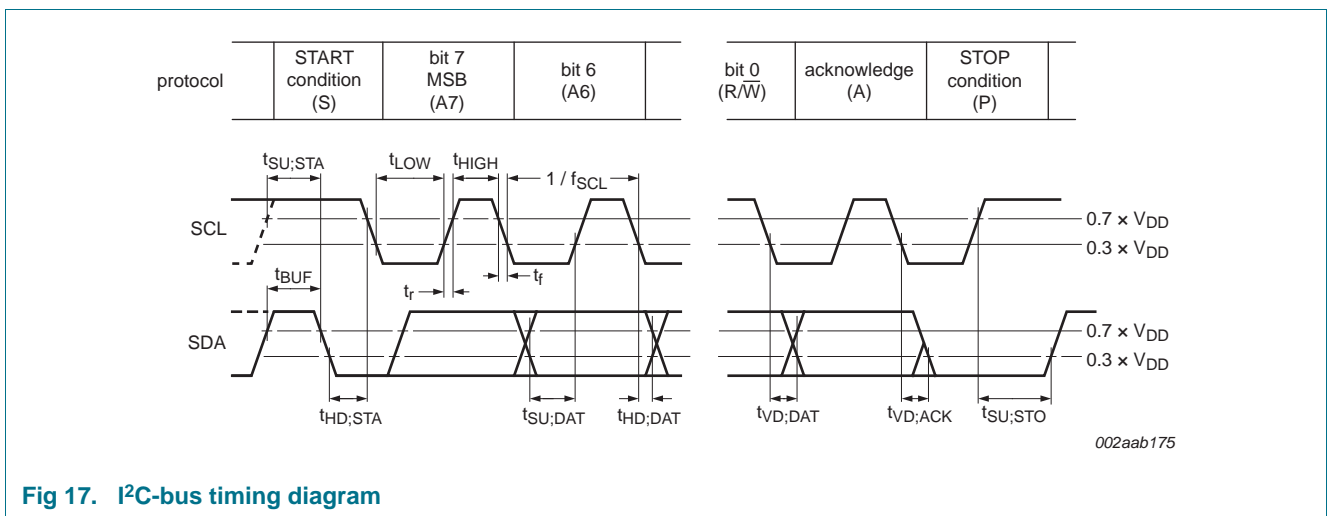

Fig 17. I<sup>2</sup>C-bus timing diagram

13. Package outline

SO24: plastic small outline package; 24 leads; body width 7.5 mm

SOT137-1

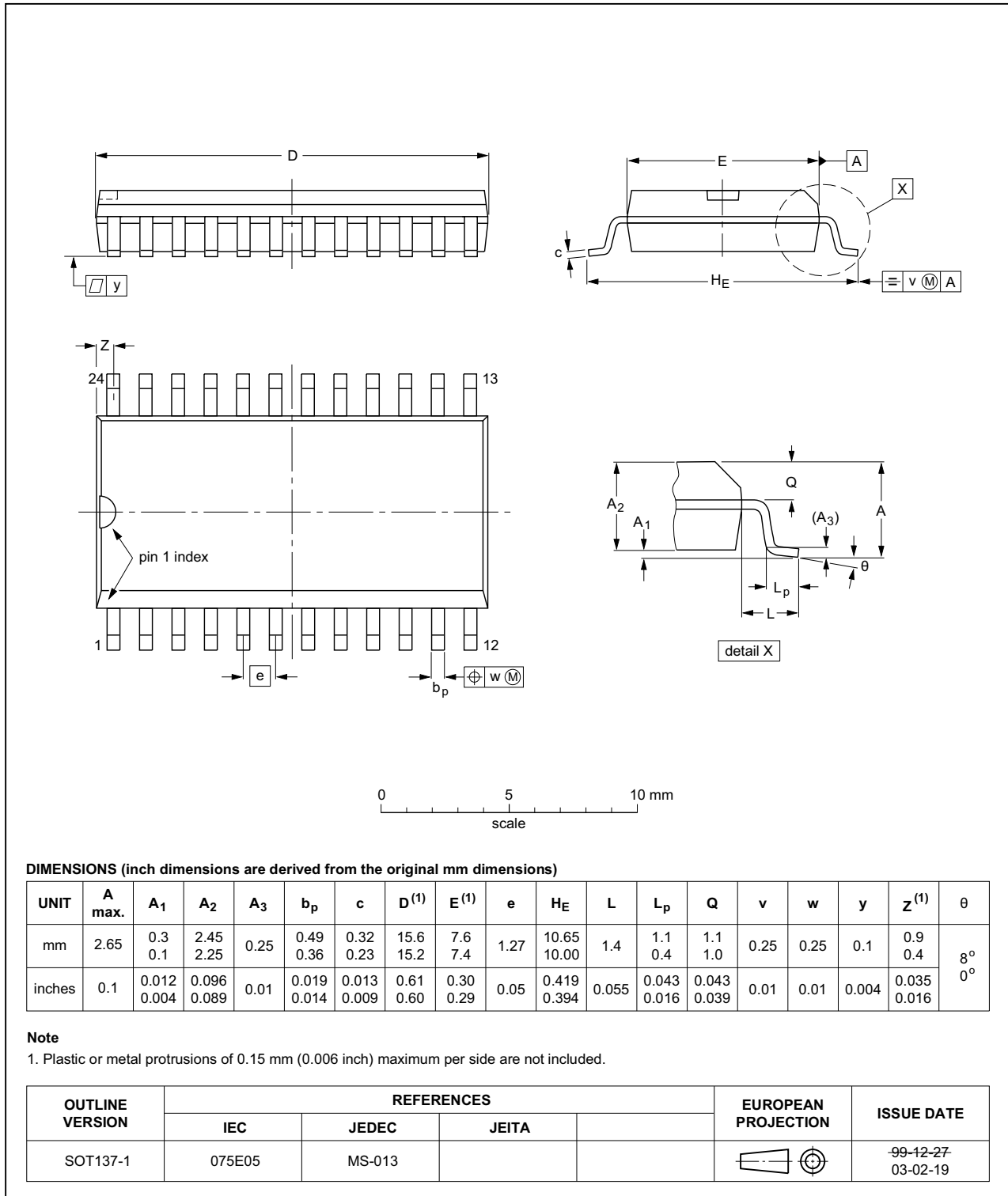

Fig 18. Package outline SOT137-1 (SO24)

TSSOP24: plastic thin shrink small outline package; 24 leads; body width 4.4 mm

SOT355-1

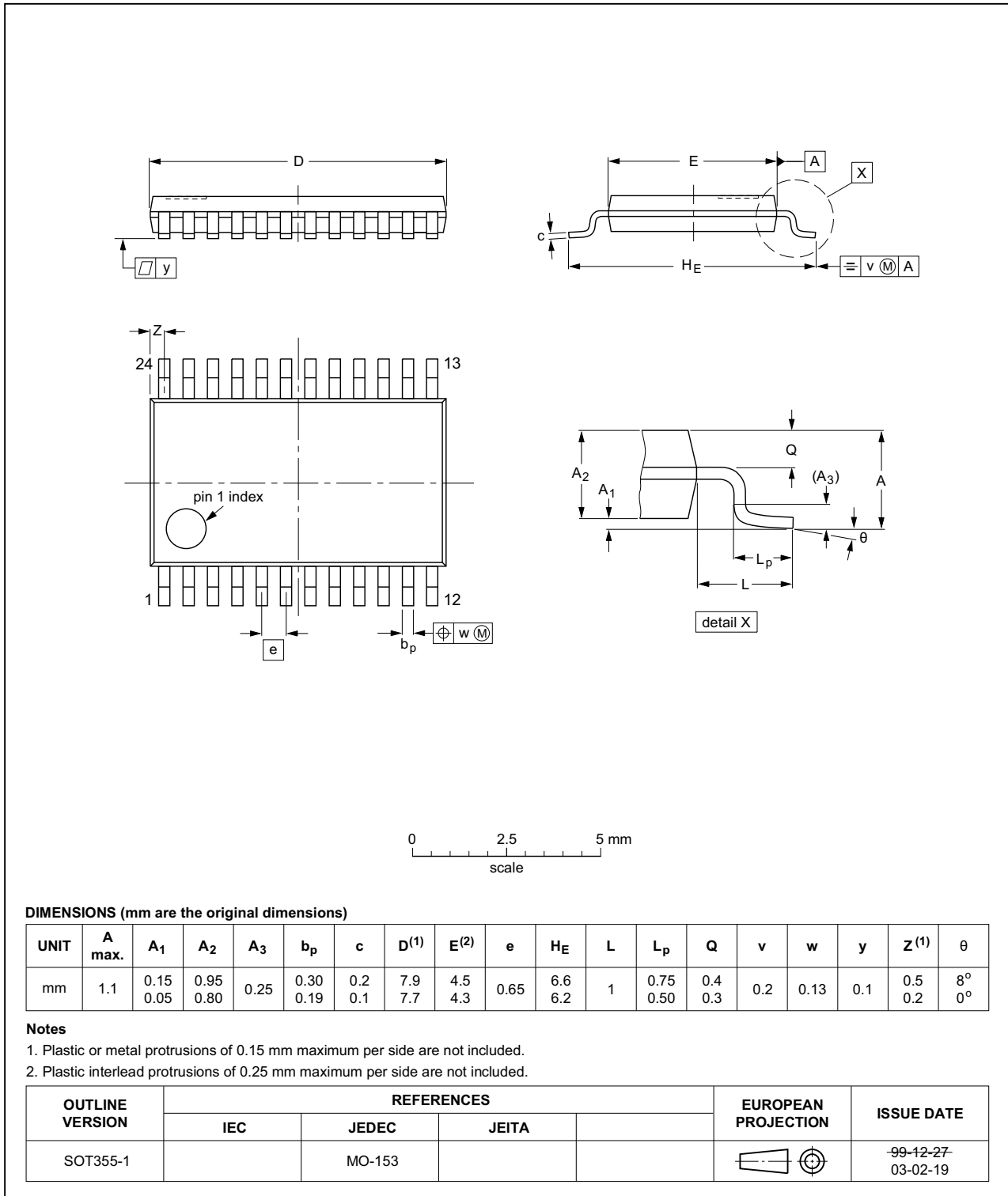
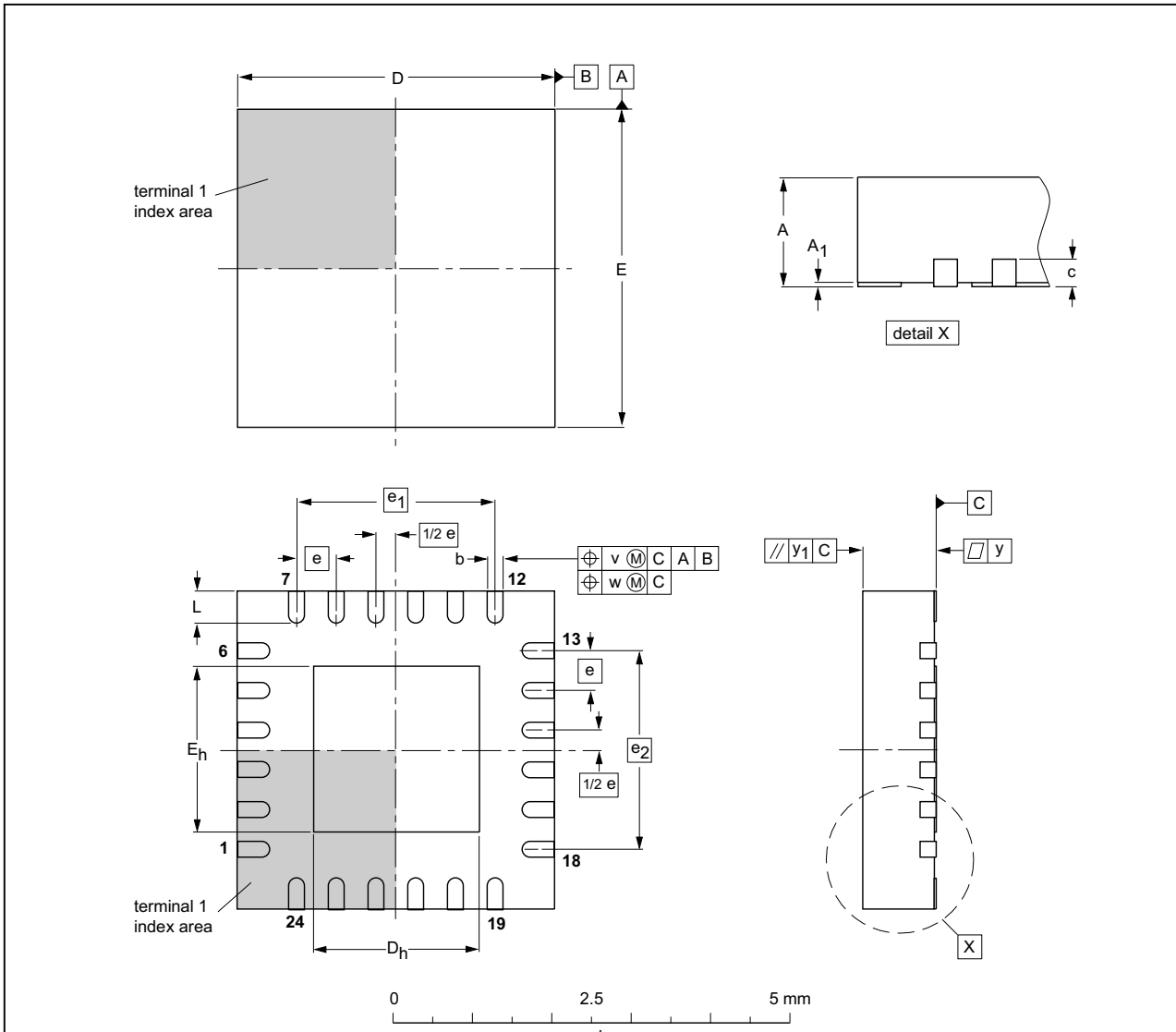

Fig 19. Package outline SOT355-1 (TSSOP24)

HVQFN24: plastic thermal enhanced very thin quad flat package; no leads;  
24 terminals; body 4 x 4 x 0.85 mm

SOT616-1



DIMENSIONS (mm are the original dimensions)

UNIT	A <sup>(1)</sup> max.	A <sub>1</sub>	b	c	D <sup>(1)</sup>	D <sub>h</sub>	E <sup>(1)</sup>	E <sub>h</sub>	e	e <sub>1</sub>	e <sub>2</sub>	L	v	w	y	y <sub>1</sub>
mm	1	0.05 0.00	0.30 0.18	0.2	4.1 3.9	2.25 1.95	4.1 3.9	2.25 1.95	0.5	2.5	2.5	0.5 0.3	0.1	0.05	0.05	0.1

Note

1. Plastic or metal protrusions of 0.075 mm maximum per side are not included.

OUTLINE VERSION	REFERENCES				EUROPEAN PROJECTION	ISSUE DATE
	IEC	JEDEC	JEITA			
SOT616-1	---	MO-220	---			01-08-08 02-10-22

Fig 20. Package outline SOT616-1 (HVQFN24)

## 14. Soldering of SMD packages

This text provides a very brief insight into a complex technology. A more in-depth account of soldering ICs can be found in Application Note AN10365 “Surface mount reflow soldering description”.

### 14.1 Introduction to soldering

Soldering is one of the most common methods through which packages are attached to Printed Circuit Boards (PCBs), to form electrical circuits. The soldered joint provides both the mechanical and the electrical connection. There is no single soldering method that is ideal for all IC packages. Wave soldering is often preferred when through-hole and Surface Mount Devices (SMDs) are mixed on one printed wiring board; however, it is not suitable for fine pitch SMDs. Reflow soldering is ideal for the small pitches and high densities that come with increased miniaturization.

### 14.2 Wave and reflow soldering

Wave soldering is a joining technology in which the joints are made by solder coming from a standing wave of liquid solder. The wave soldering process is suitable for the following:

- Through-hole components
- Leaded or leadless SMDs, which are glued to the surface of the printed circuit board

Not all SMDs can be wave soldered. Packages with solder balls, and some leadless packages which have solder lands underneath the body, cannot be wave soldered. Also, leaded SMDs with leads having a pitch smaller than ~0.6 mm cannot be wave soldered, due to an increased probability of bridging.

The reflow soldering process involves applying solder paste to a board, followed by component placement and exposure to a temperature profile. Leaded packages, packages with solder balls, and leadless packages are all reflow solderable.

Key characteristics in both wave and reflow soldering are:

- Board specifications, including the board finish, solder masks and vias
- Package footprints, including solder thieves and orientation
- The moisture sensitivity level of the packages
- Package placement
- Inspection and repair
- Lead-free soldering versus SnPb soldering

### 14.3 Wave soldering

Key characteristics in wave soldering are:

- Process issues, such as application of adhesive and flux, clinching of leads, board transport, the solder wave parameters, and the time during which components are exposed to the wave
- Solder bath specifications, including temperature and impurities

## 14.4 Reflow soldering

Key characteristics in reflow soldering are:

- Lead-free versus SnPb soldering; note that a lead-free reflow process usually leads to higher minimum peak temperatures (see [Figure 21](#)) than a SnPb process, thus reducing the process window
- Solder paste printing issues including smearing, release, and adjusting the process window for a mix of large and small components on one board
- Reflow temperature profile; this profile includes preheat, reflow (in which the board is heated to the peak temperature) and cooling down. It is imperative that the peak temperature is high enough for the solder to make reliable solder joints (a solder paste characteristic). In addition, the peak temperature must be low enough that the packages and/or boards are not damaged. The peak temperature of the package depends on package thickness and volume and is classified in accordance with [Table 10](#) and [11](#)

**Table 10. SnPb eutectic process (from J-STD-020D)**

Package thickness (mm)	Package reflow temperature (°C)	
	Volume (mm <sup>3</sup> )	
	< 350	≥ 350
< 2.5	235	220
≥ 2.5	220	220

**Table 11. Lead-free process (from J-STD-020D)**

Package thickness (mm)	Package reflow temperature (°C)		
	Volume (mm <sup>3</sup> )		
	< 350	350 to 2000	> 2000
< 1.6	260	260	260
1.6 to 2.5	260	250	245
> 2.5	250	245	245

Moisture sensitivity precautions, as indicated on the packing, must be respected at all times.

Studies have shown that small packages reach higher temperatures during reflow soldering, see [Figure 21](#).

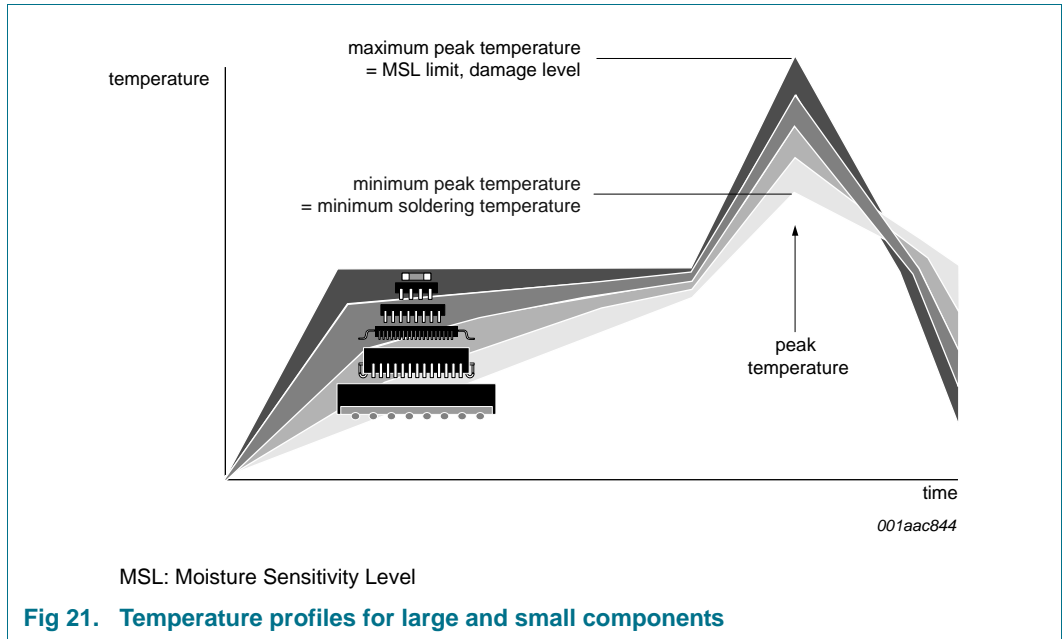

For further information on temperature profiles, refer to Application Note AN10365 “Surface mount reflow soldering description”.

15. Soldering: PCB footprints

Footprint information for reflow soldering of SO24 package

SOT137-1

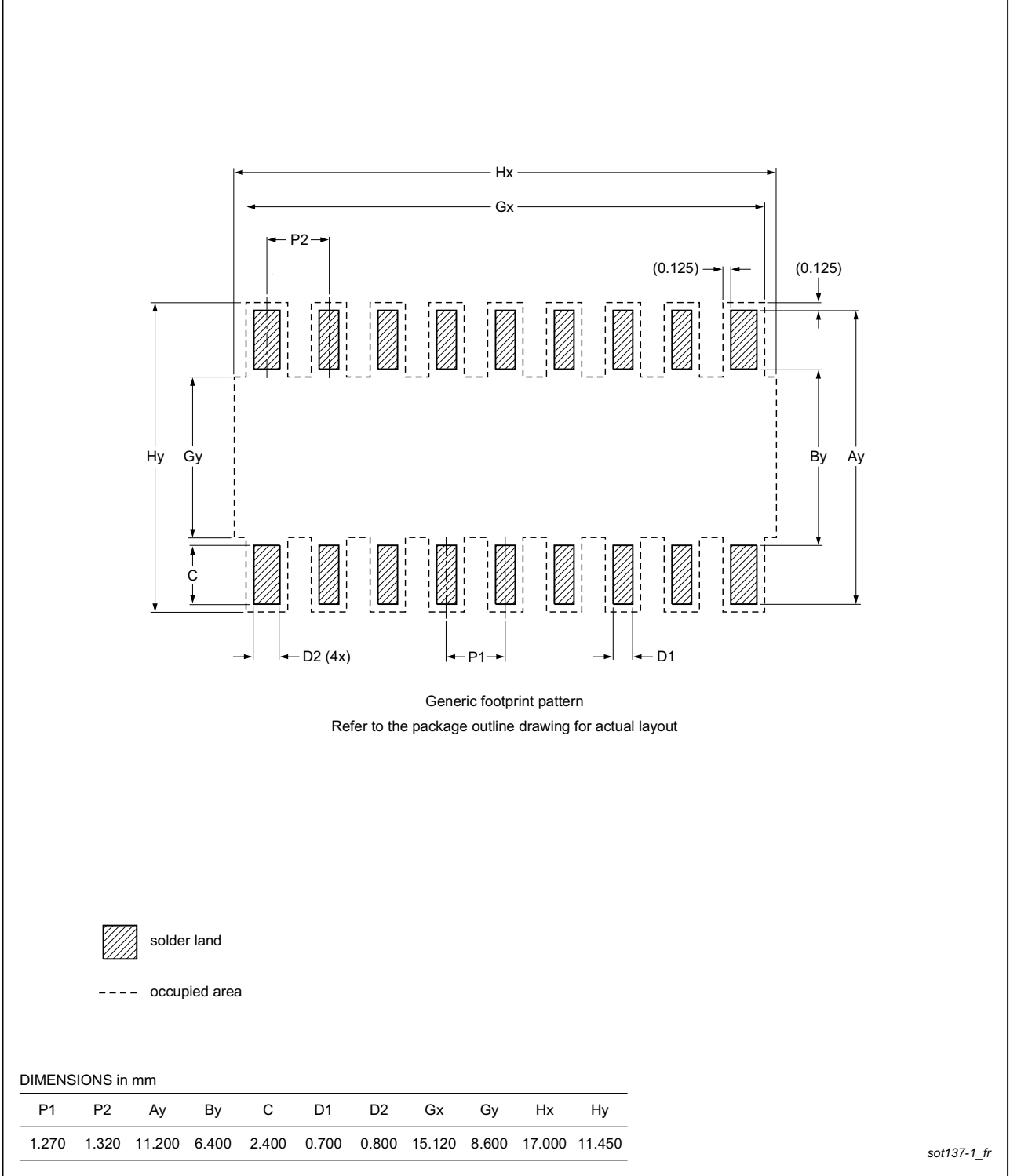

Fig 22. PCB footprint for SOT137-1 (SO24); reflow soldering

Footprint information for reflow soldering of TSSOP24 package

SOT355-1

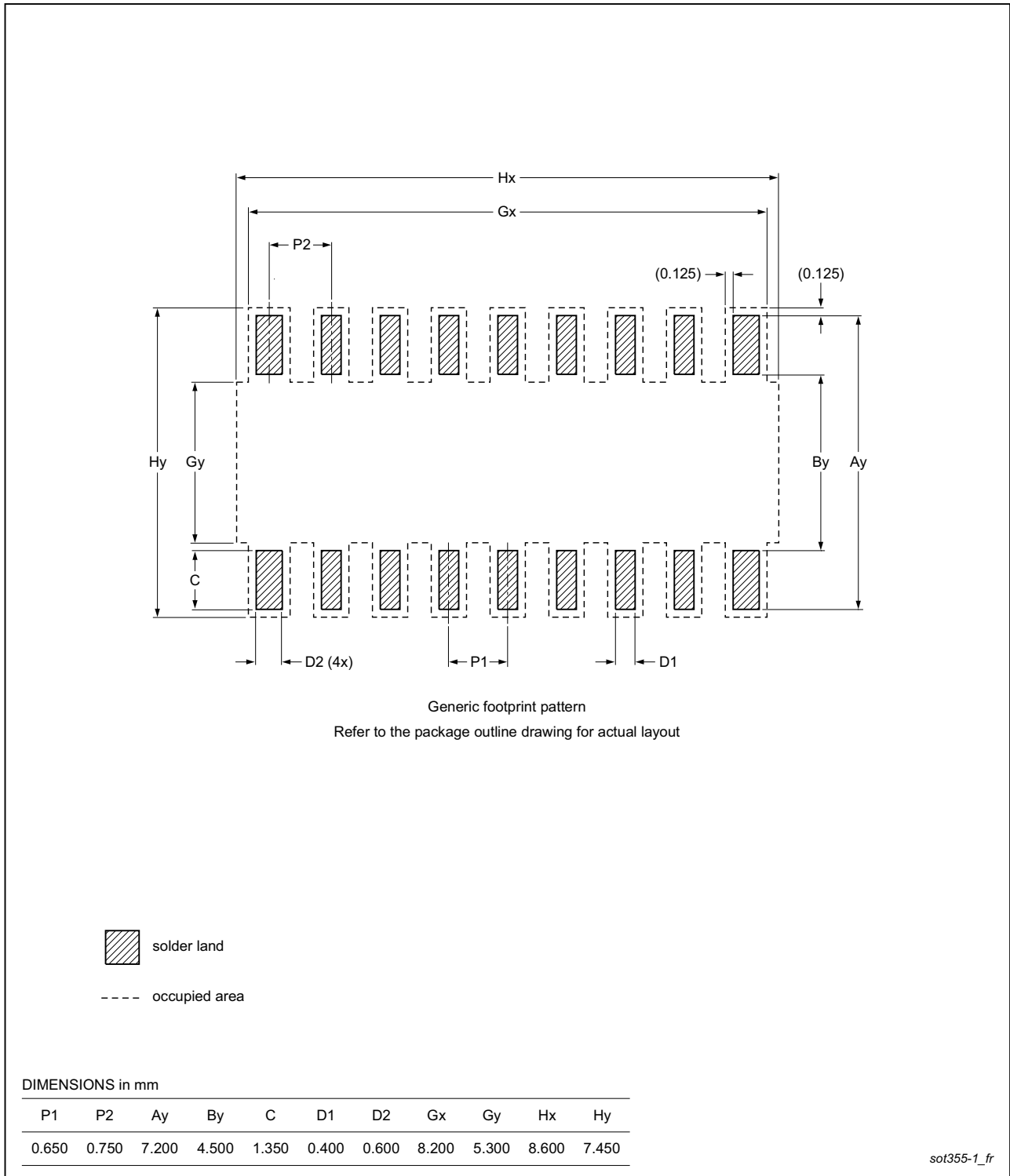

Fig 23. PCB footprint for SOT355-1 (TSSOP24); reflow soldering

Footprint information for reflow soldering of HVQFN24 package

SOT616-1

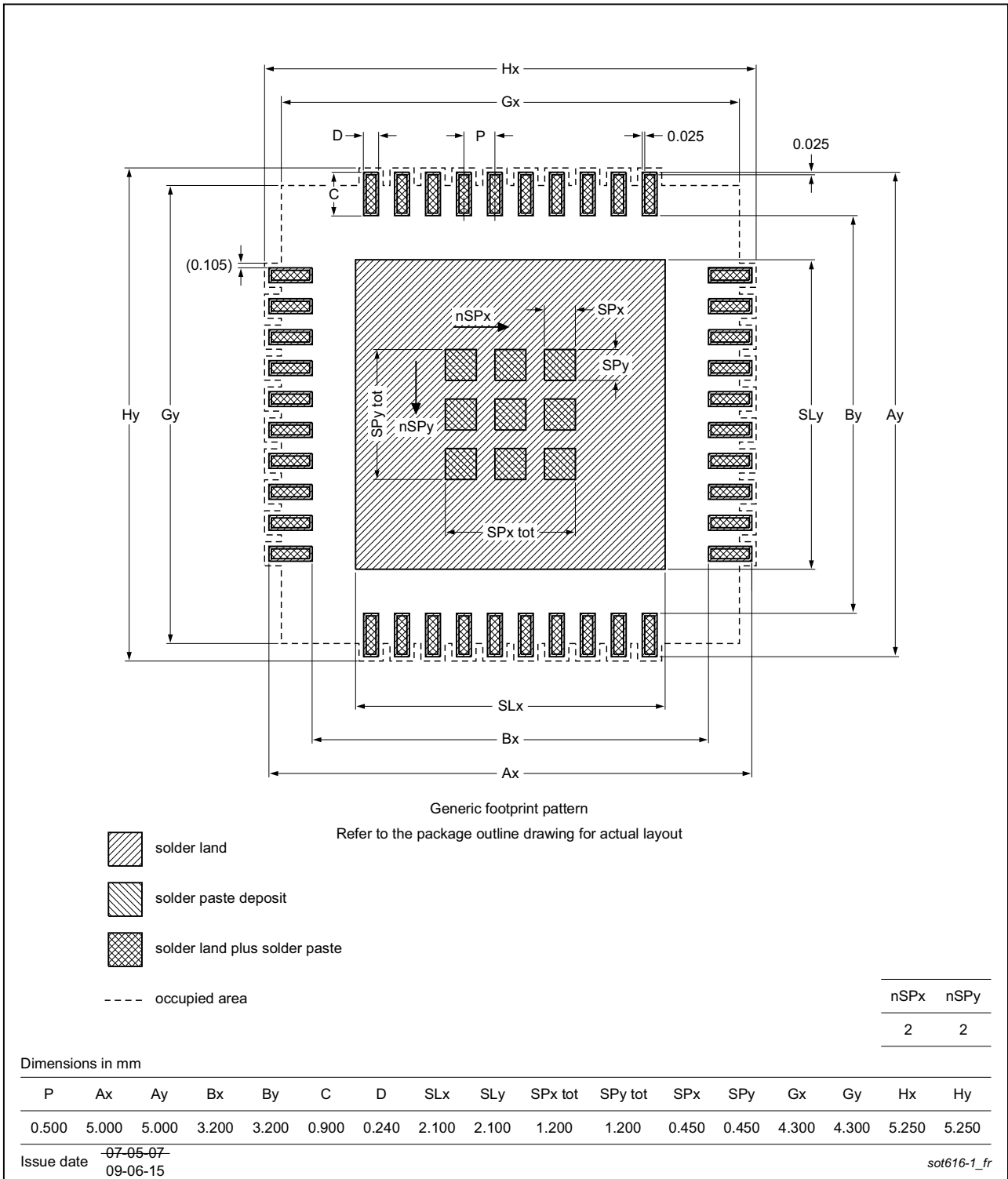

Fig 24. PCB footprint for SOT616-1 (HVQFN24); reflow soldering

## 16. Abbreviations

Table 12. Abbreviations

Acronym	Description
CDM	Charged Device Model
ESD	ElectroStatic Discharge
HBM	Human Body Model
IC	Integrated Circuit
I <sup>2</sup> C-bus	Inter-Integrated Circuit bus
I/O	Input/Output
LSB	Least Significant Bit
MSB	Most Significant Bit
PCB	Printed-Circuit Board
POR	Power-On Reset
SMBus	System Management Bus

## 17. Revision history

Table 13. Revision history

Document ID	Release date	Data sheet status	Change notice	Supersedes
PCA9548A v.5.1	20151001	Product data sheet	-	PCA9548A v.5
Modifications:	<ul style="list-style-type: none"> <li>• <a href="#">Section 6.2.1 "Control register definition"</a>, first paragraph, third sentence: corrected from "The 2 LSBs of the control byte..." to "The contents of the control byte..."</li> </ul>			
PCA9548A v.5	20140331	Product data sheet	-	PCA9548A v.4
PCA9548A v.4	20130215	Product data sheet	-	PCA9548A v.3
PCA9548A v.3	20090707	Product data sheet	-	PCA9548A v.2
PCA9548A v.2	20060925	Product data sheet	-	PCA9548A v.1
PCA9548A v.1	20050415	Product data sheet	-	-

## 18. Legal information

### 18.1 Data sheet status

Document status <sup>[1][2]</sup>	Product status <sup>[3]</sup>	Definition
Objective [short] data sheet	Development	This document contains data from the objective specification for product development.
Preliminary [short] data sheet	Qualification	This document contains data from the preliminary specification.
Product [short] data sheet	Production	This document contains the product specification.

[1] Please consult the most recently issued document before initiating or completing a design.

[2] The term 'short data sheet' is explained in section "Definitions".

[3] The product status of device(s) described in this document may have changed since this document was published and may differ in case of multiple devices. The latest product status information is available on the Internet at URL <http://www.nxp.com>.

### 18.2 Definitions

**Draft** — The document is a draft version only. The content is still under internal review and subject to formal approval, which may result in modifications or additions. NXP Semiconductors does not give any representations or warranties as to the accuracy or completeness of information included herein and shall have no liability for the consequences of use of such information.

**Short data sheet** — A short data sheet is an extract from a full data sheet with the same product type number(s) and title. A short data sheet is intended for quick reference only and should not be relied upon to contain detailed and full information. For detailed and full information see the relevant full data sheet, which is available on request via the local NXP Semiconductors sales office. In case of any inconsistency or conflict with the short data sheet, the full data sheet shall prevail.

**Product specification** — The information and data provided in a Product data sheet shall define the specification of the product as agreed between NXP Semiconductors and its customer, unless NXP Semiconductors and customer have explicitly agreed otherwise in writing. In no event however, shall an agreement be valid in which the NXP Semiconductors product is deemed to offer functions and qualities beyond those described in the Product data sheet.

### 18.3 Disclaimers

**Limited warranty and liability** — Information in this document is believed to be accurate and reliable. However, NXP Semiconductors does not give any representations or warranties, expressed or implied, as to the accuracy or completeness of such information and shall have no liability for the consequences of use of such information. NXP Semiconductors takes no responsibility for the content in this document if provided by an information source outside of NXP Semiconductors.

In no event shall NXP Semiconductors be liable for any indirect, incidental, punitive, special or consequential damages (including - without limitation - lost profits, lost savings, business interruption, costs related to the removal or replacement of any products or rework charges) whether or not such damages are based on tort (including negligence), warranty, breach of contract or any other legal theory.

Notwithstanding any damages that customer might incur for any reason whatsoever, NXP Semiconductors' aggregate and cumulative liability towards customer for the products described herein shall be limited in accordance with the *Terms and conditions of commercial sale* of NXP Semiconductors.

**Right to make changes** — NXP Semiconductors reserves the right to make changes to information published in this document, including without limitation specifications and product descriptions, at any time and without notice. This document supersedes and replaces all information supplied prior to the publication hereof.

**Suitability for use** — NXP Semiconductors products are not designed, authorized or warranted to be suitable for use in life support, life-critical or safety-critical systems or equipment, nor in applications where failure or malfunction of an NXP Semiconductors product can reasonably be expected to result in personal injury, death or severe property or environmental damage. NXP Semiconductors and its suppliers accept no liability for inclusion and/or use of NXP Semiconductors products in such equipment or applications and therefore such inclusion and/or use is at the customer's own risk.

**Applications** — Applications that are described herein for any of these products are for illustrative purposes only. NXP Semiconductors makes no representation or warranty that such applications will be suitable for the specified use without further testing or modification.

Customers are responsible for the design and operation of their applications and products using NXP Semiconductors products, and NXP Semiconductors accepts no liability for any assistance with applications or customer product design. It is customer's sole responsibility to determine whether the NXP Semiconductors product is suitable and fit for the customer's applications and products planned, as well as for the planned application and use of customer's third party customer(s). Customers should provide appropriate design and operating safeguards to minimize the risks associated with their applications and products.

NXP Semiconductors does not accept any liability related to any default, damage, costs or problem which is based on any weakness or default in the customer's applications or products, or the application or use by customer's third party customer(s). Customer is responsible for doing all necessary testing for the customer's applications and products using NXP Semiconductors products in order to avoid a default of the applications and the products or of the application or use by customer's third party customer(s). NXP does not accept any liability in this respect.

**Limiting values** — Stress above one or more limiting values (as defined in the Absolute Maximum Ratings System of IEC 60134) will cause permanent damage to the device. Limiting values are stress ratings only and (proper) operation of the device at these or any other conditions above those given in the Recommended operating conditions section (if present) or the Characteristics sections of this document is not warranted. Constant or repeated exposure to limiting values will permanently and irreversibly affect the quality and reliability of the device.

**Terms and conditions of commercial sale** — NXP Semiconductors products are sold subject to the general terms and conditions of commercial sale, as published at <http://www.nxp.com/profile/terms>, unless otherwise agreed in a valid written individual agreement. In case an individual agreement is concluded only the terms and conditions of the respective agreement shall apply. NXP Semiconductors hereby expressly objects to applying the customer's general terms and conditions with regard to the purchase of NXP Semiconductors products by customer.

**No offer to sell or license** — Nothing in this document may be interpreted or construed as an offer to sell products that is open for acceptance or the grant, conveyance or implication of any license under any copyrights, patents or other industrial or intellectual property rights.

**Export control** — This document as well as the item(s) described herein may be subject to export control regulations. Export might require a prior authorization from competent authorities.

**Non-automotive qualified products** — Unless this data sheet expressly states that this specific NXP Semiconductors product is automotive qualified, the product is not suitable for automotive use. It is neither qualified nor tested in accordance with automotive testing or application requirements. NXP Semiconductors accepts no liability for inclusion and/or use of non-automotive qualified products in automotive equipment or applications.

In the event that customer uses the product for design-in and use in automotive applications to automotive specifications and standards, customer (a) shall use the product without NXP Semiconductors' warranty of the product for such automotive applications, use and specifications, and (b) whenever customer uses the product for automotive applications beyond NXP Semiconductors' specifications such use shall be solely at customer's

own risk, and (c) customer fully indemnifies NXP Semiconductors for any liability, damages or failed product claims resulting from customer design and use of the product for automotive applications beyond NXP Semiconductors' standard warranty and NXP Semiconductors' product specifications.

**Translations** — A non-English (translated) version of a document is for reference only. The English version shall prevail in case of any discrepancy between the translated and English versions.

## 18.4 Trademarks

Notice: All referenced brands, product names, service names and trademarks are the property of their respective owners.

**I<sup>2</sup>C-bus** — logo is a trademark of NXP Semiconductors N.V.

## 19. Contact information

For more information, please visit: <http://www.nxp.com>

For sales office addresses, please send an email to: [salesaddresses@nxp.com](mailto:salesaddresses@nxp.com)

## 20. Contents

<b>1</b>	<b>General description</b> .....	<b>1</b>
<b>2</b>	<b>Features and benefits</b> .....	<b>1</b>
<b>3</b>	<b>Ordering information</b> .....	<b>2</b>
3.1	Ordering options .....	2
<b>4</b>	<b>Block diagram</b> .....	<b>3</b>
<b>5</b>	<b>Pinning information</b> .....	<b>4</b>
5.1	Pinning .....	4
5.2	Pin description .....	5
<b>6</b>	<b>Functional description</b> .....	<b>6</b>
6.1	Device address .....	6
6.2	Control register .....	6
6.2.1	Control register definition .....	7
6.3	RESET input .....	7
6.4	Power-on reset .....	7
6.5	Voltage translation .....	8
<b>7</b>	<b>Characteristics of the I<sup>2</sup>C-bus</b> .....	<b>9</b>
7.1	Bit transfer .....	9
7.2	START and STOP conditions .....	9
7.3	System configuration .....	9
7.4	Acknowledge .....	10
7.5	Bus transactions .....	11
<b>8</b>	<b>Application design-in information</b> .....	<b>12</b>
<b>9</b>	<b>Limiting values</b> .....	<b>13</b>
<b>10</b>	<b>Thermal characteristics</b> .....	<b>13</b>
<b>11</b>	<b>Static characteristics</b> .....	<b>14</b>
<b>12</b>	<b>Dynamic characteristics</b> .....	<b>16</b>
<b>13</b>	<b>Package outline</b> .....	<b>18</b>
<b>14</b>	<b>Soldering of SMD packages</b> .....	<b>21</b>
14.1	Introduction to soldering .....	21
14.2	Wave and reflow soldering .....	21
14.3	Wave soldering .....	21
14.4	Reflow soldering .....	22
<b>15</b>	<b>Soldering: PCB footprints</b> .....	<b>24</b>
<b>16</b>	<b>Abbreviations</b> .....	<b>27</b>
<b>17</b>	<b>Revision history</b> .....	<b>27</b>
<b>18</b>	<b>Legal information</b> .....	<b>28</b>
18.1	Data sheet status .....	28
18.2	Definitions .....	28
18.3	Disclaimers .....	28
18.4	Trademarks .....	29
<b>19</b>	<b>Contact information</b> .....	<b>29</b>
<b>20</b>	<b>Contents</b> .....	<b>30</b>

Please be aware that important notices concerning this document and the product(s) described herein, have been included in section 'Legal information'.

© NXP B.V. 2015.

All rights reserved.

For more information, please visit: <http://www.nxp.com>

For sales office addresses, please send an email to: [salesaddresses@nxp.com](mailto:salesaddresses@nxp.com)

Date of release: 1 October 2015

Document identifier: PCA9548A

## Looking for pricing, stock, or lifecycle information?

Click below to explore more details on WIN SOURCE:

- ⊖ [View PCA9548ABS,118 on WIN SOURCE](#)
- ⊖ [NXP / Nexperia Information](#)

## Optimize Your Supply Chain with WIN SOURCE Solutions

- ✓ Global Sourcing Solution
- ✓ Obsolete Management
- ✓ Cost Control Management
- ✓ Shortage Management
- ✓ Alternative Solution
- ✓ Excess Inventory Management