



THE DATASHEET OF PCA9538PWR



PCA9538 Remote 8-Bit I²C AND SMBus Low-power I/O Expander with Interrupt Output, Reset, and Configuration Registers

1 Features

- Low standby current consumption of 1 μ A max
- I²C to parallel port expander
- Open-drain active-low interrupt output
- Active-low reset input
- Operating power-supply voltage range of 2.3 V to 5.5 V
- 5-V Tolerant I/O ports
- 400-kHz Fast I²C bus
- Two hardware address pins allow up to four devices on the I²C/SMBus
- Input and output configuration register
- Polarity inversion register
- Power-up with all channels configured as inputs
- No glitch on power up
- Noise filter on SCL/SDA inputs
- Latched outputs with high-current drive maximum capability for directly driving LEDs
- Latch-up performance exceeds 100 mA Per JESD 78, class II
- ESD protection exceeds JESD 22
 - 2000-V Human-body model (A114-A)
 - 200-V Machine model (A115-A)
 - 1000-V Charged-device model (C101)

2 Description

The PCA9538 is an 8-bit I/O expander of general purpose parallel input and output (I/O) expansion for the two-line bidirectional I²C bus (or SMBus) protocol. This device can operate with a power supply range from 2.3 V to 5.5 V. This device supports both 100-kHz (Standard-mode) and 400-kHz (Fast-mode) clock frequencies. This device, along with other I/O expanders, provides a simple solution when additional I/Os are needed for switches, sensors, push-buttons, LEDs, fans, and so on.

The features of PCA9538 include an interrupt that is generated on the INT pin whenever an input port changes state. The A0 and A1 hardware selectable address pins allow up to four PCA9538 devices on the same I²C bus. This device can also be reset to its default state by using the RESET feature or by cycling the power supply to cause a power-on reset.

$\overline{\text{INT}}$ can be connected to the interrupt input of a microcontroller. By sending an interrupt signal on this line, the remote I/O can inform the microcontroller if there is incoming data on its ports without having to communicate via the I²C bus. Thus, the PCA9538 can remain a simple slave device.

The device outputs (latched) have high-current drive capability for directly driving LEDs. It has low current consumption.

Two hardware pins (A0 and A1) are used to program and vary the fixed I²C address and allow up to four devices to share the same I²C bus or SMBus.

Device Information

PART NUMBER	PACKAGE ⁽¹⁾	BODY SIZE (NOM)
PCA9538	SSOP (16)	6.20 mm × 5.30 mm
	TVSOP (16)	3.60 mm × 4.40 mm
	SOIC (16)	10.30 mm × 7.50 mm
	TSSOP (16)	5.00 mm × 4.40 mm

(1) For all available packages, see the orderable addendum at the end of the datasheet.

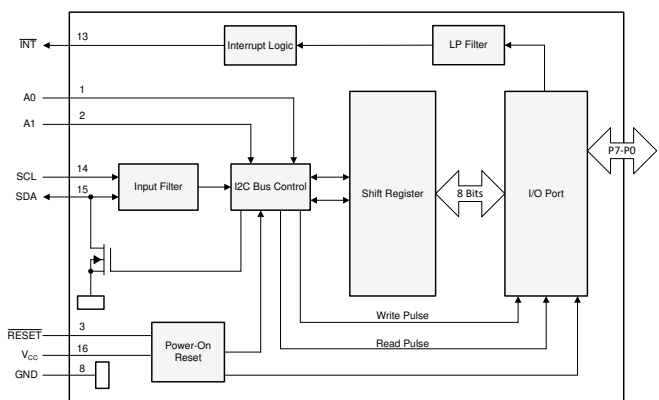

Block Diagram

Table of Contents

1 Features	1	7.2 Device Functional Modes.....	16
2 Description	1	7.3 Programming.....	17
3 Revision History	2	7.4 Register Maps.....	19
4 Pin Configuration and Functions	3	8 Application Information Disclaimer	24
5 Specifications	4	8.1 Application Information Disclaimer.....	24
5.1 Absolute Maximum Ratings.....	4	8.2 Typical Application.....	24
5.2 ESD Ratings.....	4	9 Power Supply Recommendations	26
5.3 Recommended Operating Conditions.....	4	9.1 Power-On Reset Requirements.....	26
5.4 Thermal Information.....	5	10 Device and Documentation Support	28
5.5 Electrical Characteristics.....	5	10.1 Receiving Notification of Documentation Updates.....	28
5.6 I ² C Interface Timing Requirements.....	7	10.2 Support Resources.....	28
5.7 $\overline{\text{RESET}}$ Timing Requirements.....	8	10.3 Trademarks.....	28
5.8 Switching Characteristics.....	8	10.4 Electrostatic Discharge Caution.....	28
5.9 Typical Characteristics.....	9	10.5 Glossary.....	28
6 Parameter Measurement Information	11	11 Mechanical, Packaging, and Orderable Information	28
7 Detailed Description	15		
7.1 Functional Block Diagram.....	15		

3 Revision History

Changes from Revision F (May 2014) to Revision G (March 2021)	Page
• Updated the <i>Description</i> and added the <i>Block Diagram</i> image.....	1
• Deleted RGV and RGT packages from the <i>Pin Configuration and Functions</i> section.....	3
• Moved the "Storage temperature range" to the <i>Absolute Maximum Ratings</i>	4
• Moved the "Package thermal impedance" to the <i>Thermal Resistance Characteristic</i>	4
• Changed the V _{IH} High-level input voltage (SDL, SDA) Max value From: 5.5 V To: V _{CC} in the <i>Recommended Operating Conditions</i>	4
• Changed the V _{IH} High-level input voltage (A0, A1, A2, P7–P0) MIN value From: 2 V To: 0.7 x V _{CC} in the <i>Recommended Operating Conditions</i>	4
• Changed the V _{IL} Low-level input voltage (A0, A1, A2, P7–P0) MAX value From: 0.8 V To: 0.3 x V _{CC} in the <i>Recommended Operating Conditions</i>	4
• Added the <i>Thermal Information</i> table.....	5
• Changed the V _{PORR} TYP value From: 1.5 V to: 1.2 V and the MAX value From: 1.65 V To: 1.5 V in the <i>Electrical Characteristics</i>	5
• Added the V _{PORF} row in the <i>Electrical Characteristics</i>	5
• Changed the I _{OL} ($\overline{\text{INT}}$) row TYP value From: 10 mA to: 7 mA in the <i>Electrical Characteristics</i>	5
• Changed the I _{CC} Standby mode values in the <i>Electrical Characteristics</i>	5
• Changed the Δ I _{CC} Additional current in standby mode (5.5 V) MAX value From: 1 mA To: 4 mA in the <i>Electrical Characteristics</i>	5
• Added Note 4 to the <i>Electrical Characteristics</i>	5
• Changed the <i>Typical Characteristics</i> graphs.....	9
• Changed the <i>Power Supply Recommendations</i>	26

Changes from Revision E (September 2008) to Revision F (May 2014)	Page
• Added $\overline{\text{RESET}}$ Errata section.....	16
• Added Interrupt Errata section	17

4 Pin Configuration and Functions

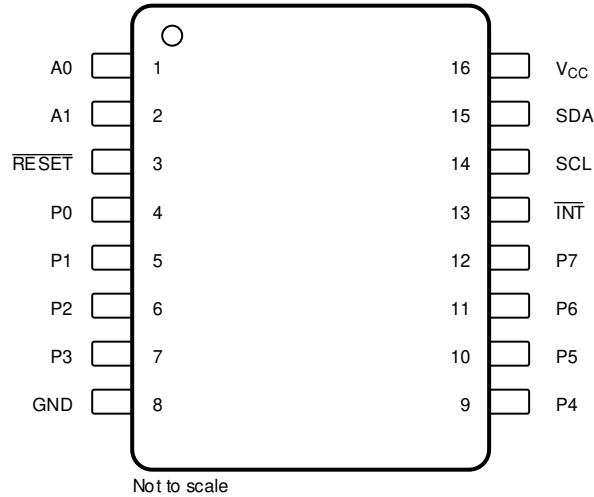

Figure 4-1. DBQ, DB, PW, DGV Package, 16-Pin, Top View

Table 4-1. Pin Functions

PIN		DESCRIPTION
NAME	NO.	
A0	1	Address input. Connect directly to V_{CC} or ground
A1	2	Address input. Connect directly to V_{CC} or ground.
GND	8	Ground
\overline{INT}	13	Interrupt output. Connect to V_{CC} through a pullup resistor
P0	4	P-port input-output. Push-pull design structure
P1	5	P-port input-output. Push-pull design structure
P2	6	P-port input-output. Push-pull design structure
P3	7	P-port input-output. Push-pull design structure
P4	9	P-port input-output. Push-pull design structure
P5	10	P-port input-output. Push-pull design structure
P6	11	P-port input-output. Push-pull design structure
P7	12	P-port input-output. Push-pull design structure
\overline{RESET}	3	Active-low reset input. Connect to V_{CC} through a pullup resistor if no active connection is used
SCL	14	Serial clock bus. Connect to V_{CC} through a pullup resistor
SDA	15	Serial data bus. Connect to V_{CC} through a pullup resistor
V_{CC}	16	Supply voltage

5 Specifications

5.1 Absolute Maximum Ratings

over operating free-air temperature range (unless otherwise noted) ⁽¹⁾

		MIN	MAX	UNIT	
V _{CC}	Supply voltage	-0.5	6	V	
V _I	Input voltage ⁽²⁾	-0.5	6	V	
V _O	Output voltage ⁽²⁾	-0.5	6	V	
I _{IK}	Input clamp current	V _I < 0		-20	mA
I _{OK}	Output clamp current	V _O < 0		-20	mA
I _{IOK}	Input/output clamp current	V _O < 0 or V _O > V _{CC}		±20	mA
I _{OL}	Continuous output low current	V _O = 0 to V _{CC}		50	mA
I _{OH}	Continuous output high current	V _O = 0 to V _{CC}		-50	mA
I _{CC}	Continuous current through GND			-250	mA
	Continuous current through V _{CC}			160	
T _{stg}	Storage temperature	-65	150	°C	

- (1) Stresses beyond those listed under *Absolute Maximum Ratings* may cause permanent damage to the device. These are stress ratings only, which do not imply functional operation of the device at these or any other conditions beyond those indicated under *Recommended Operating Conditions*. Exposure to absolute-maximum-rated conditions for extended periods may affect device reliability.
- (2) The input negative-voltage and output voltage ratings may be exceeded if the input and output current ratings are observed.

5.2 ESD Ratings

			MIN	MAX	UNIT
V _(ESD)	Electrostatic discharge	Human body model (HBM), per ANSI/ESDA/JEDEC JS-001, all pins ⁽¹⁾	0	2000	V
		Charged device model (CDM), per JEDEC specification JESD22-C101, all pins ⁽²⁾	0	1000	

- (1) JEDEC document JEP155 states that 500-V HBM allows safe manufacturing with a standard ESD control process.
- (2) JEDEC document JEP157 states that 250-V CDM allows safe manufacturing with a standard ESD control process.

5.3 Recommended Operating Conditions

over operating free-air temperature range (unless otherwise noted)

		MIN	MAX	UNIT	
V _{CC}	Supply voltage	2.3	5.5	V	
V _{IH}	High-level input voltage	SCL, SDA	0.7 × V _{CC}	V _{CC}	V
		A0, A1, RESET, P7-P0	0.7 × V _{CC}	5.5	
V _{IL}	Low-level input voltage	SCL, SDA	-0.5	0.3 × V _{CC}	V
		A0, A1, RESET, P7-P0	-0.5	0.3 × V _{CC}	
I _{OH}	High-level output current	P7-P0		-10	mA
I _{OL}	Low-level output current	P7-P0		25	mA
T _A	Operating free-air temperature	-40	85	°C	

5.4 Thermal Information

THERMAL METRIC ⁽¹⁾		PCA9538					UNIT
		DB (SSOP)	DBQ (SSOP)	DGV (TVSOP)	DW (SOIC)	PW (TSSOP)	
		16 PINS	16 PINS	16 PINS	16 PINS	16 PINS	
R _{θJA}	Junction-to-ambient thermal resistance	113.2	90	86	46	122	°C/W

(1) For more information about traditional and new thermal metrics, see the [Semiconductor and IC package thermal metrics](#) application report.

5.5 Electrical Characteristics

over operating free-air temperature range (unless otherwise noted)

PARAMETER		TEST CONDITIONS	V _{CC}	MIN	TYP ⁽¹⁾	MAX	UNIT
V _{IK}	Input diode clamp voltage	I _I = -18 mA	2.3 V to 5.5 V	-1.2			V
V _{PORR}	Power-on reset voltage, V _{CC} rising	V _I = V _{CC} or GND, I _O = 0			1.2	1.5	V
V _{PORF}	Power-on reset voltage, V _{C7} falling	V _I = V _{CC} or GND, I _O = 0		0.75	1		V
V _{OH}	P-port high-level output voltage ⁽²⁾	I _{OH} = -8 mA	2.3 V	1.8			V
			3 V	2.6			
			4.5 V	4.1			
			4.75 V	4.1			
		I _{OH} = -10 mA	2.3 V	1.7			
			3 V	2.5			
			4.5 V	4			
			4.75 V	4			
I _{OL}	SDA	V _{OL} = 0.4 V	2.3 V to 5.5 V	3	8		mA
	P port ⁽³⁾	V _{OL} = 0.5 V	2.3 V	8	10		
			3 V	8	14		
			4.5 V	8	17		
			4.75 V	8	35		
		V _{OL} = 0.7 V	2.3 V	10	13		
			3 V	10	19		
			4.5 V	10	24		
			4.75 V	10	45		
	INT	V _{OL} = 0.4 V	2.3 V to 5.5 V	3	7		
I _I	SCL, SDA	V _I = V _{CC} or GND	2.3 V to 5.5 V			±1	μA
	A0, A1, RESET ⁽⁴⁾					±1	
I _{IH}	P port	V _I = V _{CC}	2.3 V to 5.5 V			1	μA
I _{IL}	P port	V _I = GND	2.3 V to 5.5 V			-1	μA
I _{CC}	Operating mode	V _I = V _{CC} or GND, I _O = 0, I/O = inputs, f _{scl} = 400 kHz, no load	5.5 V		104	175	μA
			3.6 V		50	90	
			2.7 V		20	65	
		V _I = V _{CC} or GND, I _O = 0, I/O = inputs, f _{scl} = 100 kHz, no load	5.5 V		60	150	
			3.6 V		15	40	
			2.7 V		8	20	
	Standby mode	V _I = V _{CC} or GND, I _O = 0, I/O = inputs, f _{scl} = 0 kHz, no load	5.5 V		1.9	3.5	
			3.6 V		1.1	1.8	
			2.7 V		1	1.6	

5.5 Electrical Characteristics (continued)

over operating free-air temperature range (unless otherwise noted)

PARAMETER		TEST CONDITIONS	V _{CC}	MIN	TYP ⁽¹⁾	MAX	UNIT
ΔI_{CC}	Additional current in standby mode	One input at V _{CC} – 0.6 V, Other inputs at V _{CC} or GND	2.3 V to 5.5 V			1.5	mA
		All LED I/Os at V _I = 4.3 V, f _{scl} = 0 kHz	5.5 V			4	
C _i	SCL	V _I = V _{CC} or GND	2.3 V to 5.5 V		4	5	pF
C _{io}	SDA	V _{IO} = V _{CC} or GND	2.3 V to 5.5 V		5.5	6.5	pF
	P port				8	9.5	

- (1) All typical values are at nominal supply voltage (2.5-, 3.3-, or 5-V V_{CC}) and T_A = 25°C.
- (2) The total current sourced by all I/Os must be limited to 85 mA.
- (3) Each I/O must be externally limited to a maximum of 25 mA, and the P port (P7–P0) must be limited to a maximum current of 200 mA.
- (4) RESET = V_{CC} (held high) when all other input voltages, V_I = GND.

5.6 I²C Interface Timing Requirements

over operating free-air temperature range (unless otherwise noted) (see [Figure 6-1](#))

		MIN	MAX	UNIT	
STANDARD MODE					
f _{scl}	I ² C clock frequency	0	100	kHz	
t _{sch}	I ² C clock high time	4		μs	
t _{scl}	I ² C clock low time	4.7		μs	
t _{sp}	I ² C spike time		50	ns	
t _{sds}	I ² C serial-data setup time	250		ns	
t _{sdh}	I ² C serial-data hold time	0		ns	
t _{icr}	I ² C input rise time		1000	ns	
t _{icf}	I ² C input fall time		300	ns	
t _{ocf}	I ² C output fall time	10-pF to 400-pF bus	300	ns	
t _{buf}	I ² C bus free time between Stop and Start	4.7		μs	
t _{sts}	I ² C Start or repeated Start condition setup	4.7		μs	
t _{sth}	I ² C Start or repeated Start condition hold	4		μs	
t _{sps}	I ² C Stop condition setup	4		μs	
t _{vd(data)}	Valid data time	SCL low to SDA output valid	300	ns	
t _{vd(ack)}	Valid data time of ACK condition	ACK signal from SCL low to SDA (out) low	0.3	3.45	μs
C _b	I ² C bus capacitive load		400	ns	
FAST MODE					
f _{scl}	I ² C clock frequency	0	400	kHz	
t _{sch}	I ² C clock high time	0.6		μs	
t _{scl}	I ² C clock low time	1.3		μs	
t _{sp}	I ² C spike time		50	ns	
t _{sds}	I ² C serial-data setup time	100		ns	
t _{sdh}	I ² C serial-data hold time	0		ns	
t _{icr}	I ² C input rise time	20 + 0.1C _b (1)	300	ns	
t _{icf}	I ² C input fall time	20 + 0.1C _b (1)	300	ns	
t _{ocf}	I ² C output fall time	10-pF to 400-pF bus	20 + 0.1C _b (1)	300	ns
t _{buf}	I ² C bus free time between Stop and Start	1.3		μs	
t _{sts}	I ² C Start or repeated Start condition setup	0.6		μs	
t _{sth}	I ² C Start or repeated Start condition hold	0.6		μs	
t _{sps}	I ² C Stop condition setup	0.6		μs	
t _{vd(data)}	Valid data time	SCL low to SDA output valid	50	ns	
t _{vd(ack)}	Valid data time of ACK condition	ACK signal from SCL low to SDA (out) low	0.1	0.9	μs
C _b	I ² C bus capacitive load		400	ns	

(1) C_b = Total capacitance of one bus in pF

5.7 RESET Timing Requirements

over operating free-air temperature range (unless otherwise noted)

PARAMETER		MIN	MAX	UNIT
STANDARD MODE and FAST MODE				
t_W	Reset pulse duration	4		ns
t_{REC}	Reset recovery time	0		ns
t_{RESET}	Time to reset	400		ns

5.8 Switching Characteristics

over operating free-air temperature range (unless otherwise noted) (see [Figure 6-2](#) and [Figure 6-3](#))

PARAMETER		FROM (INPUT)	TO (OUTPUT)	MIN	MAX	UNIT
STANDARD MODE and FAST MODE						
t_{iv}	Interrupt valid time	P port	\overline{INT}		4	μs
t_{ir}	Interrupt reset delay time	SCL	\overline{INT}		4	μs
t_{pv}	Output data valid	SCL	P7–P0		200	ns
t_{ps}	Input data setup time	P port	SCL	100		ns
t_{ph}	Input data hold time	P port	SCL	1		μs

5.9 Typical Characteristics

$T_A = 25^\circ\text{C}$ (unless otherwise noted)

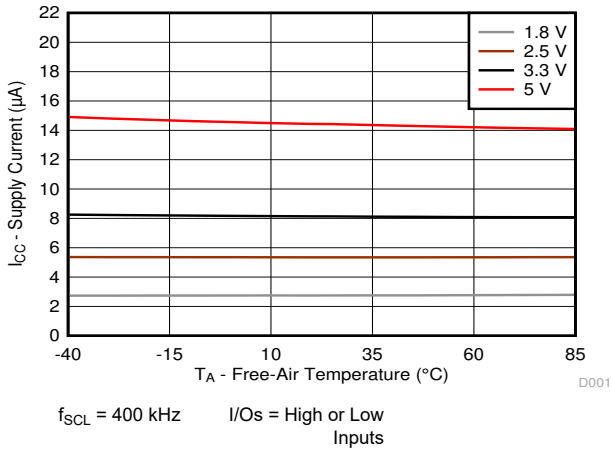

Figure 5-1. Supply Current (I_{CC} , Operating Mode) vs Temperature (T_A) at Four Supply Voltages

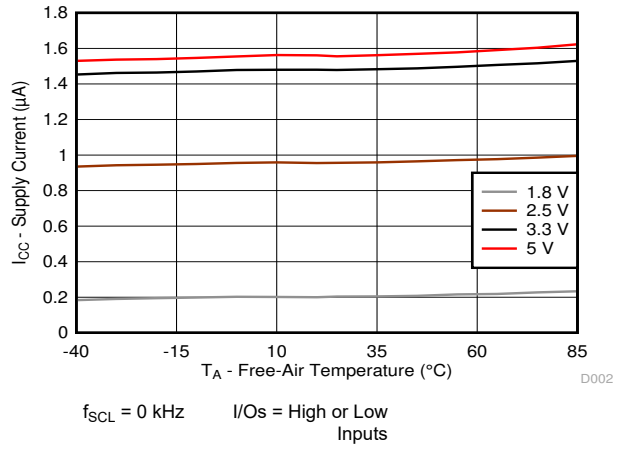

Figure 5-2. Supply Current (I_{CC} , Standby Mode) vs Temperature (T_A) at Four Supply Voltages

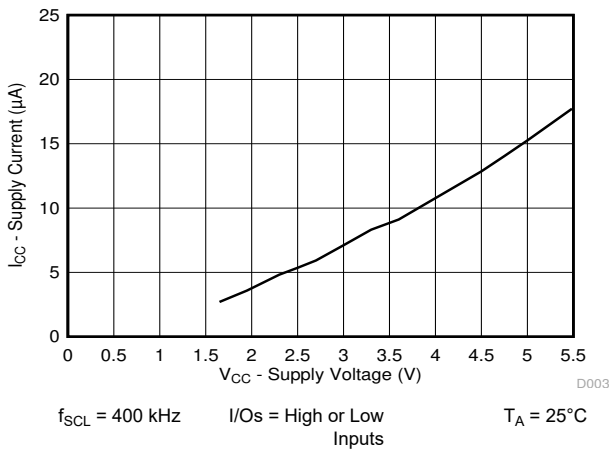

Figure 5-3. Supply Current (I_{CC} , Operating Mode) vs Supply Voltage (V_{CC})

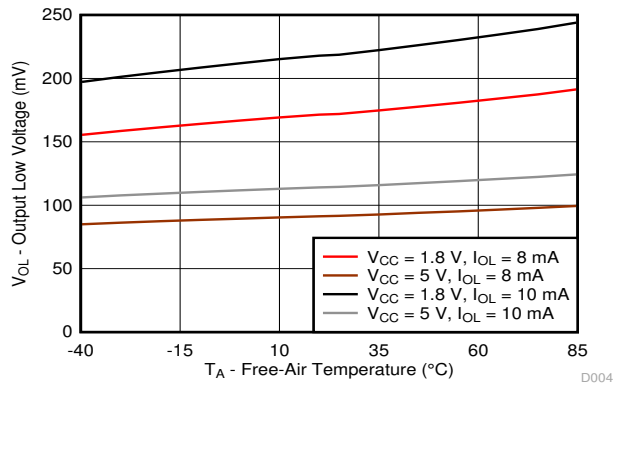

Figure 5-4. Output Low Voltage (V_{OL}) vs Temperature (T_A) for P-Port I/Os

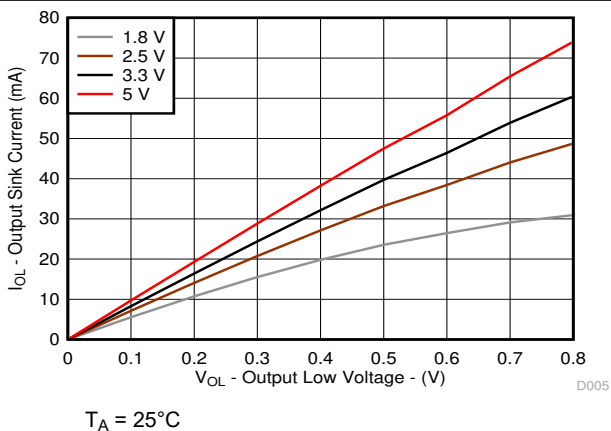

Figure 5-5. Sink Current (I_{OL}) vs Output Low Voltage (V_{OL}) for P-Ports at Four Supply Voltages

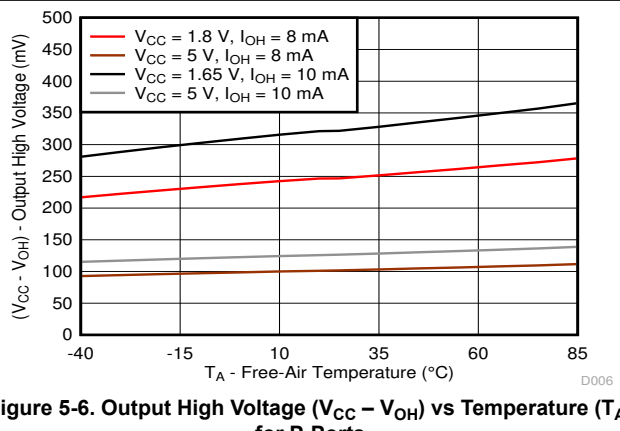
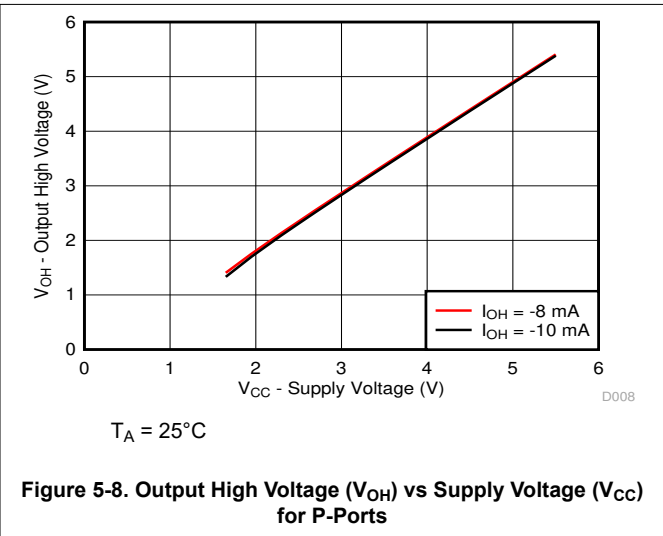
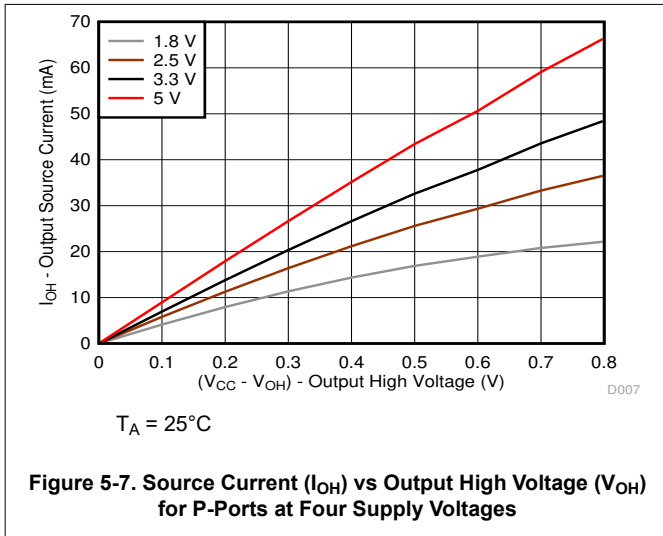

Figure 5-6. Output High Voltage ($V_{CC} - V_{OH}$) vs Temperature (T_A) for P-Ports

5.9 Typical Characteristics (continued)

T_A = 25°C (unless otherwise noted)



6 Parameter Measurement Information

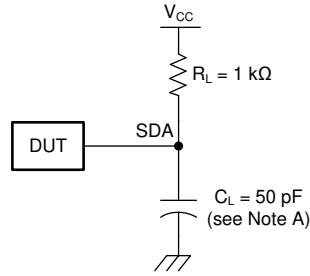

SDA LOAD CONFIGURATION

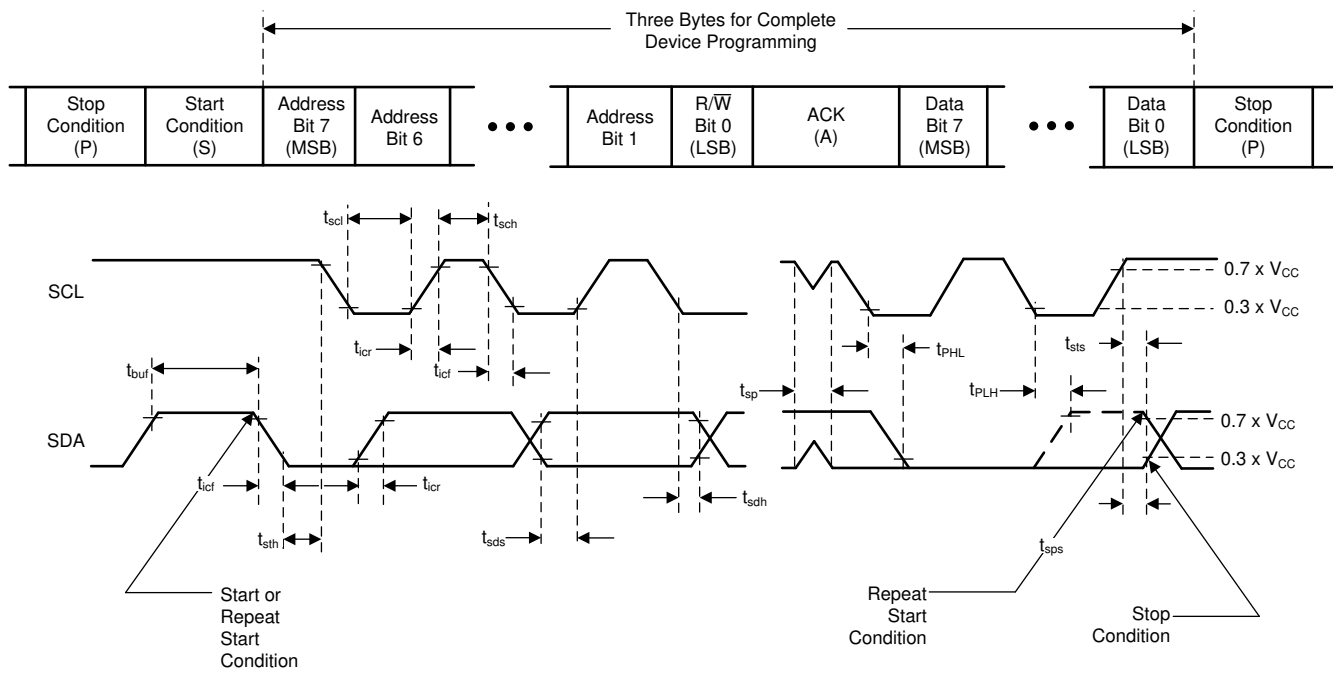

VOLTAGE WAVEFORMS

- A. C_L includes probe and jig capacitance.
- B. All inputs are supplied by generators having the following characteristics: PRR \leq 10 MHz, $Z_O = 50 \Omega$, $t_r/t_f \leq 30$ ns.
- C. All parameters and waveforms are not applicable to all devices.

Figure 6-1. I²C Interface Load Circuit and Voltage Waveforms

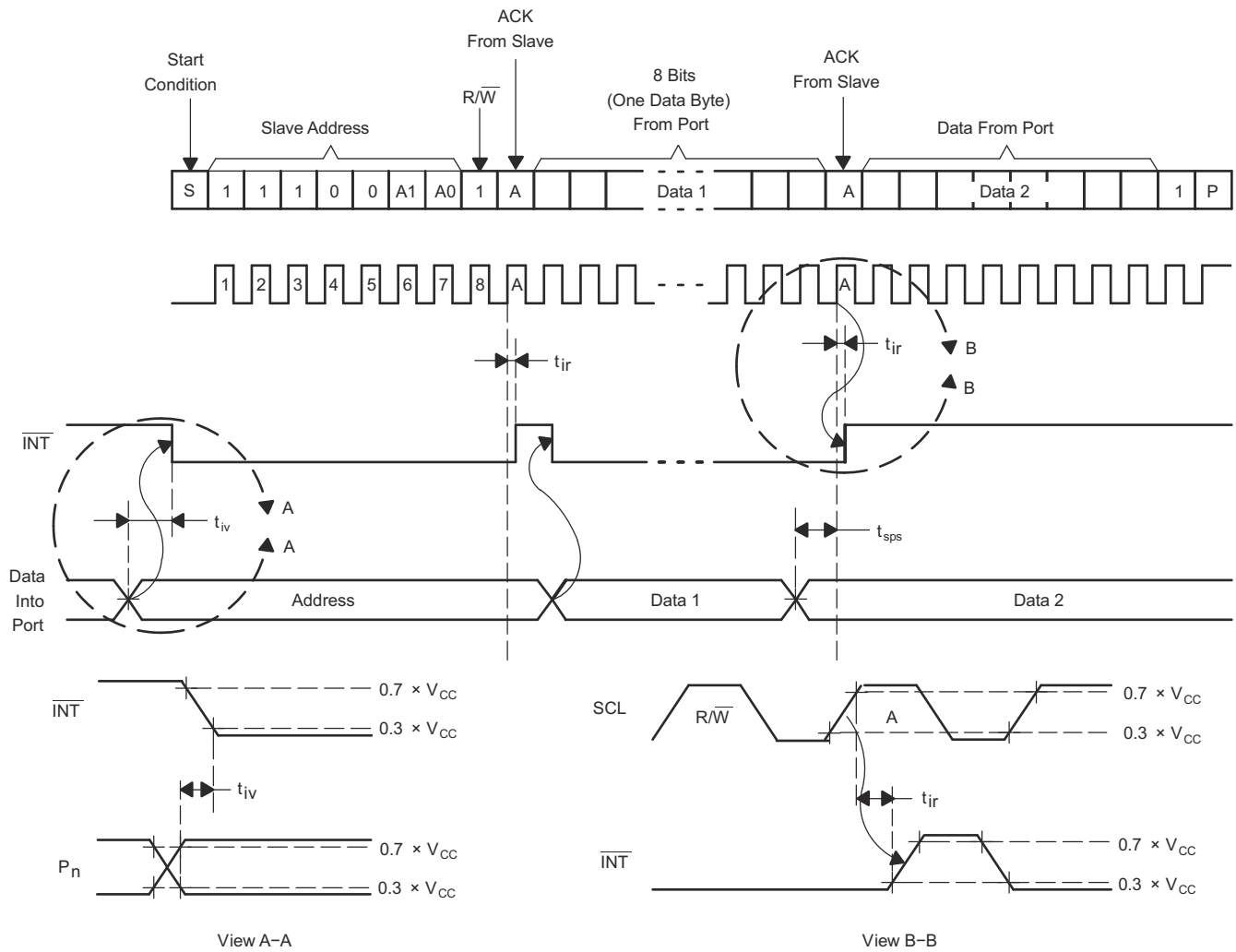
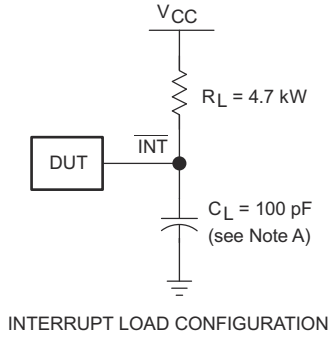

- A. C_L includes probe and jig capacitance.
- B. All inputs are supplied by generators having the following characteristics: $PRR \leq 10$ MHz, $Z_O = 50 \Omega$, $t_r/t_f \leq 30$ ns.
- C. All parameters and waveforms are not applicable to all devices.

Figure 6-2. Interrupt Load Circuit and Voltage Waveforms

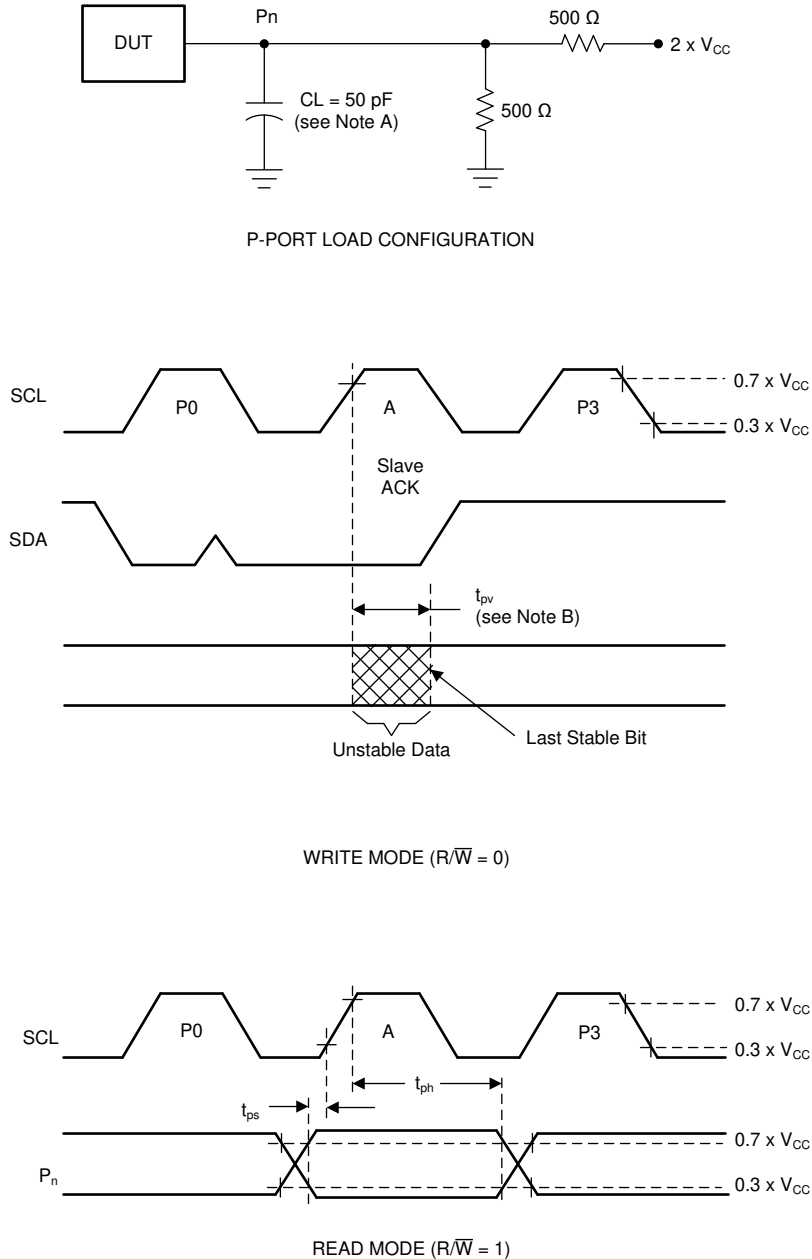

- A. C_L includes probe and jig capacitance.
- B. All inputs are supplied by generators having the following characteristics: $PRR \leq 10$ MHz, $Z_O = 50 \Omega$, $t_r/t_f \leq 30$ ns.
- C. The outputs are measured one at a time, with one transition per measurement.
- D. All parameters and waveforms are not applicable to all devices.

Figure 6-3. P-Port Load Circuit and Voltage Waveforms

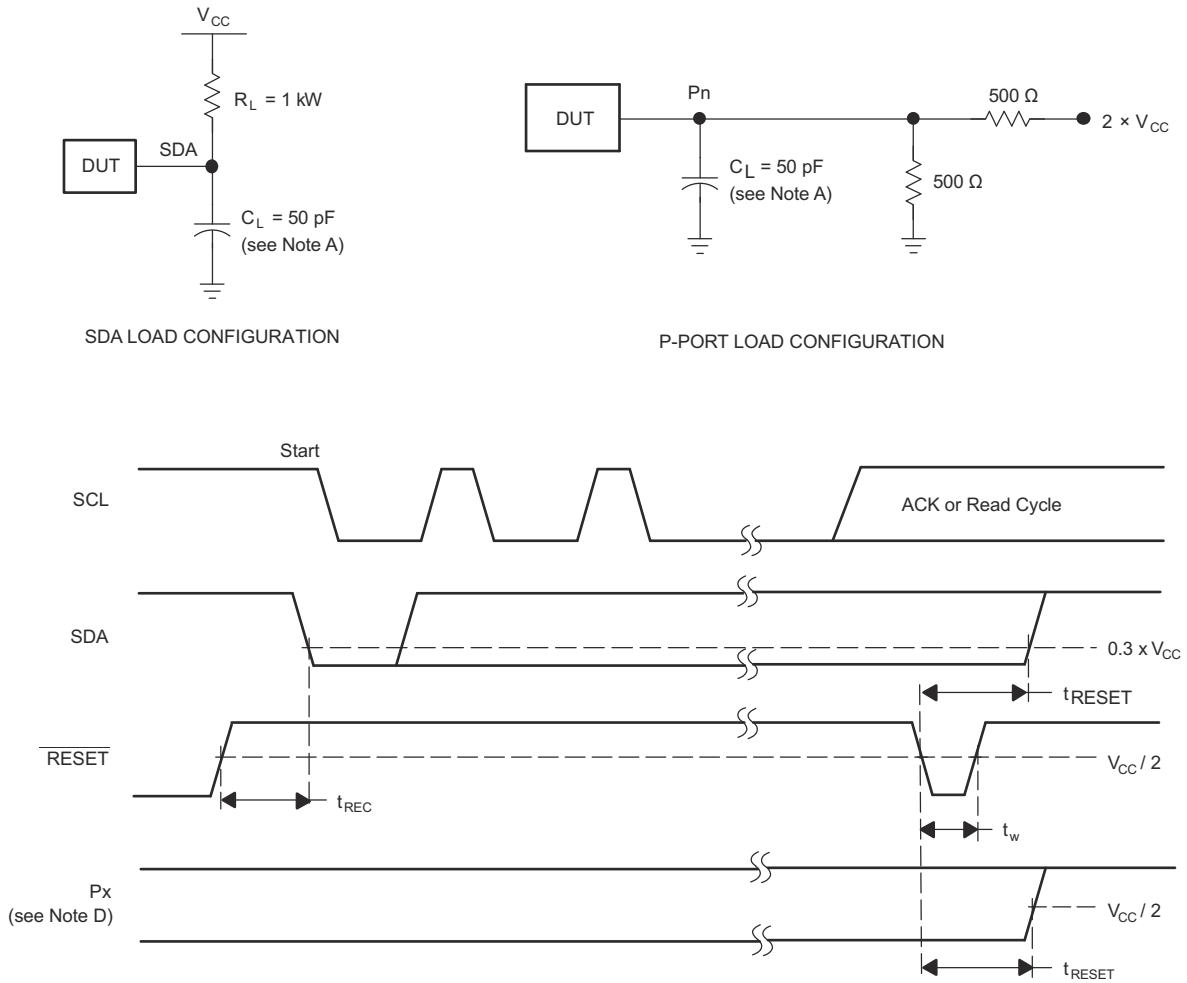

- A. C_L includes probe and jig capacitance.
- B. All inputs are supplied by generators having the following characteristics: $PRR \leq 10$ MHz, $Z_O = 50 \Omega$, $t_r/t_f \leq 30$ ns.
- C. The outputs are measured one at a time, with one transition per measurement.
- D. I/Os are configured as inputs.
- E. All parameters and waveforms are not applicable to all devices.

Figure 6-4. Reset Load Circuits and Voltage Waveforms

7 Detailed Description

7.1 Functional Block Diagram

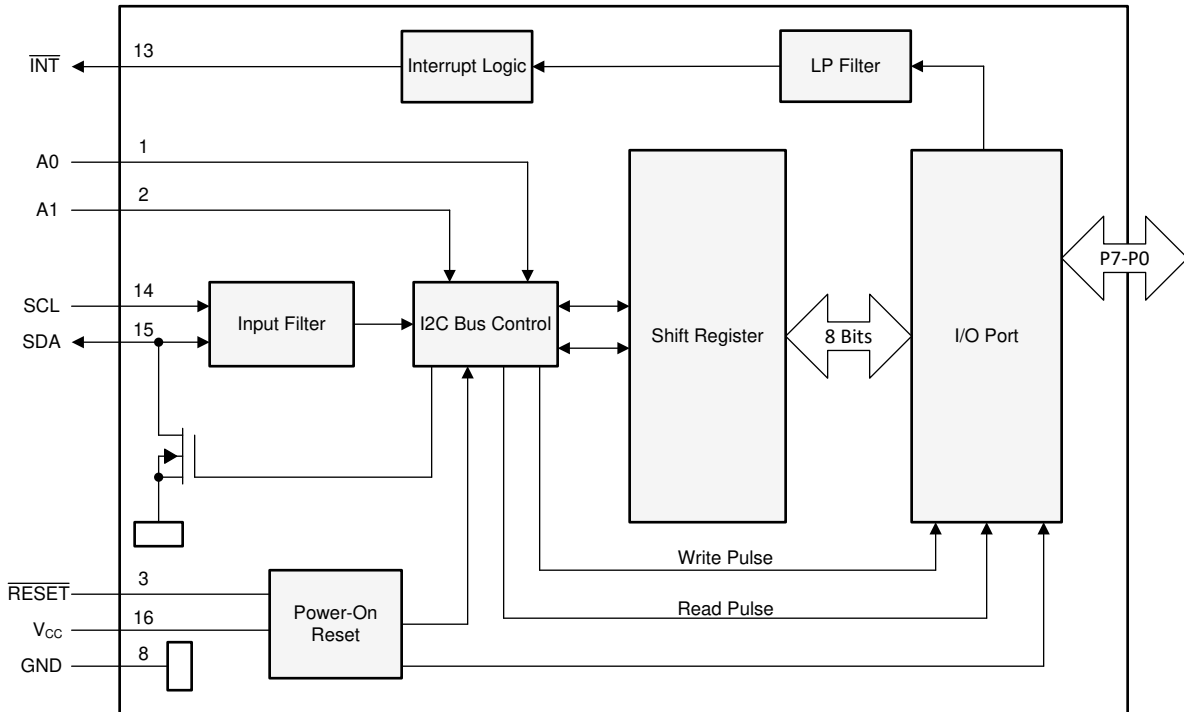

Pin numbers shown are for the DB, DBQ, DGV, DW, or PW package.

Figure 7-1. Functional Block Diagram

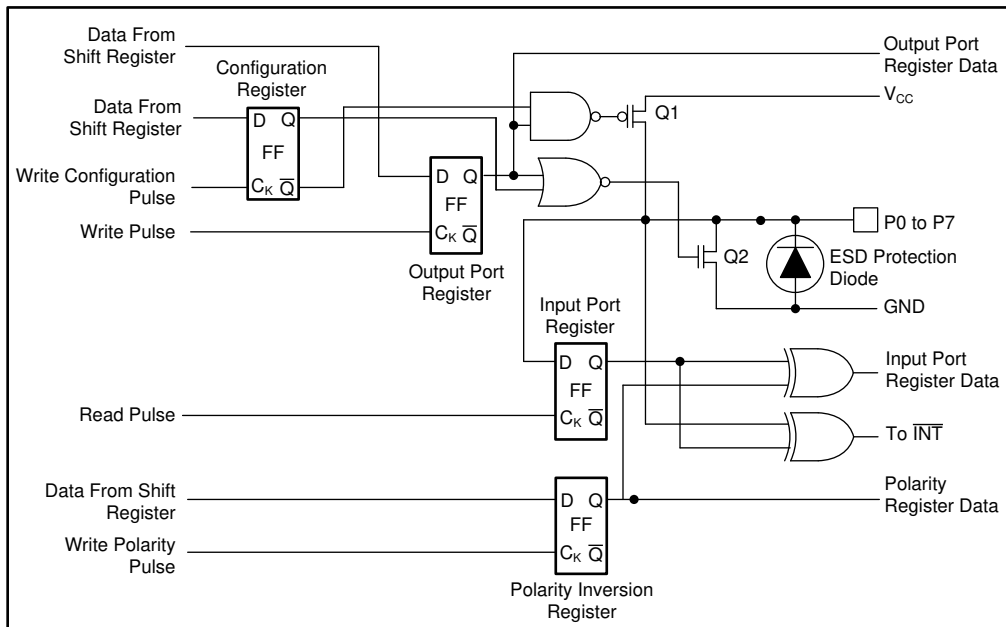

At power-on reset, all registers return to default values.

Figure 7-2. Simplified Schematic Of P0 To P7

7.2 Device Functional Modes

7.2.1 RESET Input

The $\overline{\text{RESET}}$ input can be asserted to reset the system while keeping the V_{CC} at its operating level. A reset can be accomplished by holding the $\overline{\text{RESET}}$ pin low for a minimum of t_{W} . The PCA9538 registers and I²C/SMBus state machine are changed to their default states once $\overline{\text{RESET}}$ is low (0). Once $\overline{\text{RESET}}$ is high (1), the I/O levels at the P port can be changed externally or through the master. This input requires a pullup resistor to V_{CC} if no active connection is used.

7.2.1.1 $\overline{\text{RESET}}$ Errata

If $\overline{\text{RESET}}$ voltage set higher than VCC, current flows from $\overline{\text{RESET}}$ pin to VCC pin.

System Impact

VCC is pulled above its regular voltage level.

System Workaround

Design such that $\overline{\text{RESET}}$ voltage is same or lower than VCC.

7.2.2 Power-On Reset

When power (from 0 V) is applied to V_{CC} , an internal power-on reset holds the PCA9538 in a reset condition until V_{CC} has reached V_{POR} . At that point, the reset condition is released and the PCA9538 registers and I²C/SMBus state machine initialize to their default states. After that, V_{CC} must be lowered to below 0.2 V and then back up to the operating voltage for a power-reset cycle.

7.2.3 I/O Port

When an I/O is configured as an input, FETs Q1 and Q2 (in [Figure 7-2](#)) are off, creating a high-impedance input. The input voltage may be raised above V_{CC} to a maximum of 5.5 V.

If the I/O is configured as an output, Q1 or Q2 is enabled depending on the state of the output port register. In this case, there are low impedance paths between the I/O pin and either V_{CC} or GND. The external voltage applied to this I/O pin must not exceed the recommended levels for proper operation.

7.2.4 Interrupt Output ($\overline{\text{INT}}$)

An interrupt is generated by any rising or falling edge of the port inputs in the input mode. After time, t_{iv} , the signal $\overline{\text{INT}}$ is valid. Resetting the interrupt circuit is achieved when data on the port is changed to the original setting, data is read from the port that generated the interrupt. Resetting occurs in the read mode at the acknowledge (ACK) or not acknowledge (NACK) bit after the rising edge of the SCL signal.

Interrupts that occur during the ACK or NACK clock pulse can be lost (or be very short) due to the resetting of the interrupt during this pulse. Each change of the I/Os after resetting is detected and is transmitted as $\overline{\text{INT}}$. Writing to another device does not affect the interrupt circuit, and a pin configured as an output cannot cause an interrupt. Changing an I/O from an output to an input may cause a false interrupt to occur, if the state of the pin does not match the contents of the Input Port register. Because each 8-pin port is read independently, the interrupt caused by port 0 is not cleared by a read of port 1 or vice versa.

The $\overline{\text{INT}}$ output has an open-drain structure and requires pullup resistor to V_{CC} .

7.2.4.1 Interrupt Errata

The INT will be improperly de-asserted if the following two conditions occur:

1. The last I²C command byte (register pointer) written to the device was 00h.

Note

This generally means the last operation with the device was a Read of the input register. However, the command byte may have been written with 00h without ever going on to read the input register. After reading from the device, if no other command byte written, it remains 00h.

2. Any other slave device on the I²C bus acknowledges an address byte with the R/W bit set high

System Impact

Can cause improper interrupt handling as the Master sees the interrupt as being cleared.

System Workaround

Minor software change: User must change command byte to something besides 00h after a Read operation to the PCA9538 device or before reading from another slave device.

Note

Software change are compatible with other versions (competition and TI redesigns) of this device.

7.3 Programming

7.3.1 I²C Interface

The bidirectional I²C bus consists of the serial clock (SCL) and serial data (SDA) lines. Both lines must be connected to a positive supply through a pull-up resistor when connected to the output stages of a device. Data transfer may be initiated only when the bus is not busy.

I²C communication with this device is initiated by a master sending a Start condition, a high-to-low transition on the SDA input/output while the SCL input is high (see [Figure 7-3](#)). After the Start condition, the device address byte is sent, most significant bit (MSB) first, including the data direction bit (R/ \overline{W}).

After receiving the valid address byte, this device responds with an acknowledge (ACK), a low on the SDA input/output during the high of the ACK-related clock pulse. The address inputs (A0–A1) of the slave device must not be changed between the Start and the Stop conditions.

On the I²C bus, only one data bit is transferred during each clock pulse. The data on the SDA line must remain stable during the high pulse of the clock period, as changes in the data line at this time are interpreted as control commands (Start or Stop) (see [Figure 7-4](#)).

A Stop condition, a low-to-high transition on the SDA input/output while the SCL input is high, is sent by the master (see [Figure 7-3](#)).

Any number of data bytes can be transferred from the transmitter to receiver between the Start and the Stop conditions. Each byte of eight bits is followed by one ACK bit. The transmitter must release the SDA line before the receiver can send an ACK bit. The device that acknowledges must pull down the SDA line during the ACK clock pulse so that the SDA line is stable low during the high pulse of the ACK-related clock period (see Figure 7-5). When a slave receiver is addressed, it must generate an ACK after each byte is received. Similarly, the master must generate an ACK after each byte that it receives from the slave transmitter. Setup and hold times must be met to ensure proper operation.

A master receiver signals an end of data to the slave transmitter by not generating an acknowledge (NACK) after the last byte has been clocked out of the slave. This is done by the master receiver by holding the SDA line high. In this event, the transmitter must release the data line to enable the master to generate a Stop condition.

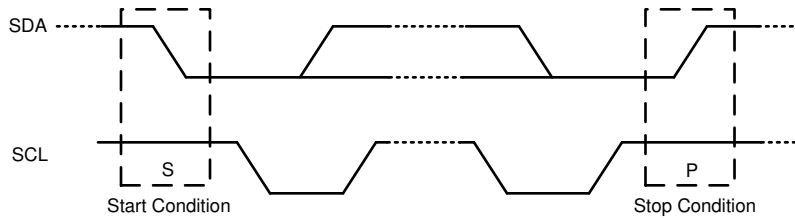

Figure 7-3. Definition Of Start And Stop Conditions

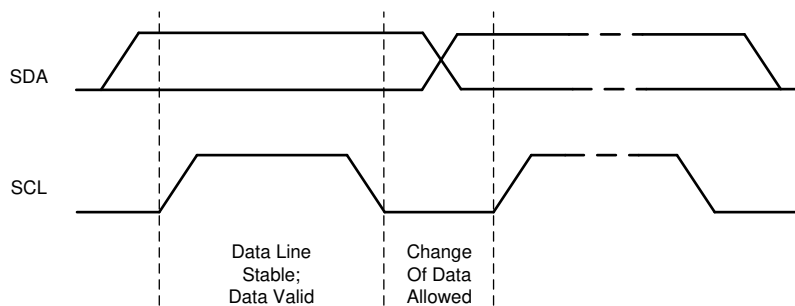

Figure 7-4. Bit Transfer

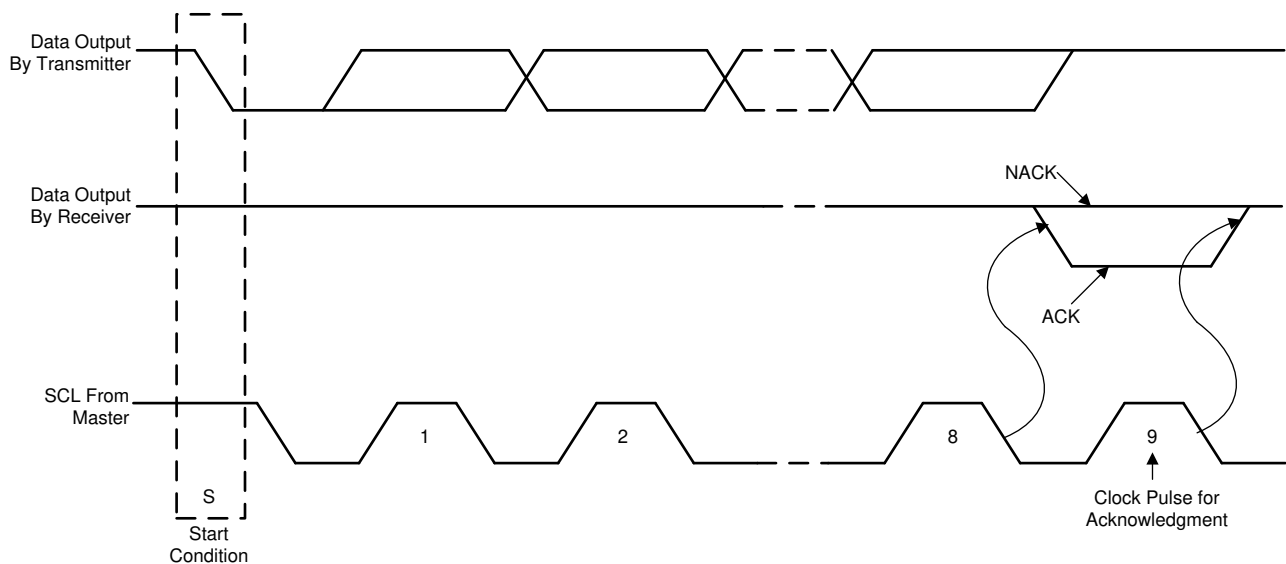

Figure 7-5. Acknowledgment On I²C Bus

7.4 Register Maps

Table 7-1 shows the address byte of the PCA9538.

Table 7-1. Interface Definition Table

BYTE	BIT							
	7 (MSB)	6	5	4	3	2	1	0 (LSB)
I ² C slave address	H	H	H	L	L	A1	A0	R/ \bar{W}
Px I/O data bus	P7	P6	P5	P4	P3	P2	P1	P0

7.4.1 Device Address

Figure 7-6 shows the address byte of the PCA9538.

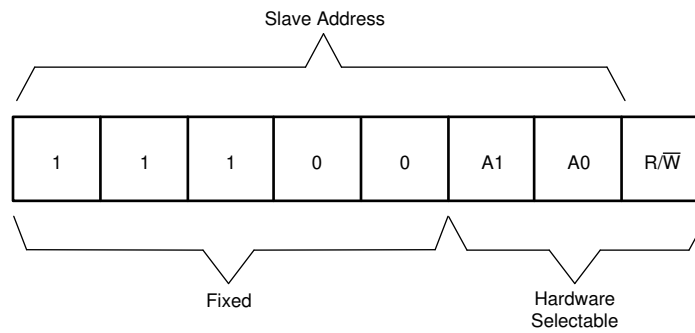

Figure 7-6. PCA9538 Address

Table 7-2 shows the PCA9538 address reference.

Table 7-2. Address Reference Table

INPUTS		I ² C BUS SLAVE ADDRESS
A1	A0	
L	L	112 (decimal), 70 (hexadecimal)
L	H	113 (decimal), 71 (hexadecimal)
H	L	114 (decimal), 72 (hexadecimal)
H	H	115 (decimal), 73 (hexadecimal)

The last bit of the slave address defines the operation (read or write) to be performed. When it is high (1), a read is selected while a low (0) selects a write operation.

7.4.2 Control Register And Command Byte

Following the successful Acknowledgment of the address byte, the bus master sends a command byte that is stored in the control register in the PCA9538 (see [Figure 7-7](#)). Two bits of this command byte state the operation (read or write) and the internal register (input, output, polarity inversion or configuration) that are affected. This register can be written or read through the I²C bus. The command byte is sent only during a write transmission.

Once a command byte has been sent, the register that was addressed continues to be accessed by reads until a new command byte has been sent.

[Figure 7-7](#) shows the PCA9538 control register bits and [Table 7-3](#) shows the command byte.

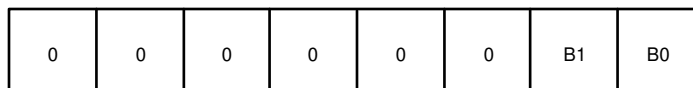
**Figure 7-7. Control Register Bits****Table 7-3. Command Byte Table**

CONTROL REGISTER BITS		COMMAND BYTE (HEX)	REGISTER	PROTOCOL	POWER-UP DEFAULT
B1	B0				
0	0	0×00	Input Port	Read byte	XXXX XXXX
0	1	0×01	Output Port	Read/write byte	1111 1111
1	0	0×02	Polarity Inversion	Read/write byte	0000 0000
1	1	0×03	Configuration	Read/write byte	1111 1111

7.4.3 Register Descriptions

The Input Port register (register 0) reflects the incoming logic levels of the pins, regardless of whether the pin is defined as an input or an output by the Configuration register. It only acts on read operation. Writes to these registers have no effect. The default value, X, is determined by the externally applied logic level.

Before a read operation, a write transmission is sent with the command byte to indicate to the I²C device that the Input Port register is accessed next. See [Table 7-4](#).

Table 7-4. Register 0 (Input Port Register) Table

BIT	I7	I6	I5	I4	I3	I2	I1	I0
DEFAULT	X	X	X	X	X	X	X	X

The Output Port register (register 1) shows the outgoing logic levels of the pins defined as outputs by the Configuration register. Bit values in this register have no effect on pins defined as inputs. In turn, reads from this register reflect the value that is in the flip-flop controlling the output selection, not the actual pin value. See [Table 7-5](#).

Table 7-5. Register 1 (Output Port Register) Table

BIT	O7	O6	O5	O4	O3	O2	O1	O0
DEFAULT	1	1	1	1	1	1	1	1

The Polarity Inversion register (register 2) allows polarity inversion of pins defined as inputs by the Configuration register. If a bit in this register is set (written with 1), the corresponding port pin polarity is inverted. If a bit in this register is cleared (written with a 0), the corresponding port pin original polarity is retained. See [Table 7-6](#).

Table 7-6. Register 2 (Polarity Inversion Register) Table

BIT	N7	N6	N5	N4	N3	N2	N1	N0
DEFAULT	0	0	0	0	0	0	0	0

The Configuration register (register 3) configures the directions of the I/O pins. If a bit in this register is set to 1, the corresponding port pin is enabled as an input with a high-impedance output driver. If a bit in this register is cleared to 0, the corresponding port pin is enabled as an output. See [Table 7-7](#).

Table 7-7. Register 3 (Configuration Register) Table

BIT	C7	C6	C5	C4	C3	C2	C1	C0
DEFAULT	1	1	1	1	1	1	1	1

7.4.4 Bus Transactions

Data is exchanged between the master and PCA9538 through write and read commands.

7.4.4.1 Writes

Data is transmitted to the PCA9538 by sending the device address and setting the least-significant bit (LSB) to a logic 0 (see Figure 7-6 for device address). The command byte is sent after the address and determines which register receives the data that follows the command byte (see Figure 7-8 and Figure 7-9). There is no limitation on the number of data bytes sent in one write transmission.

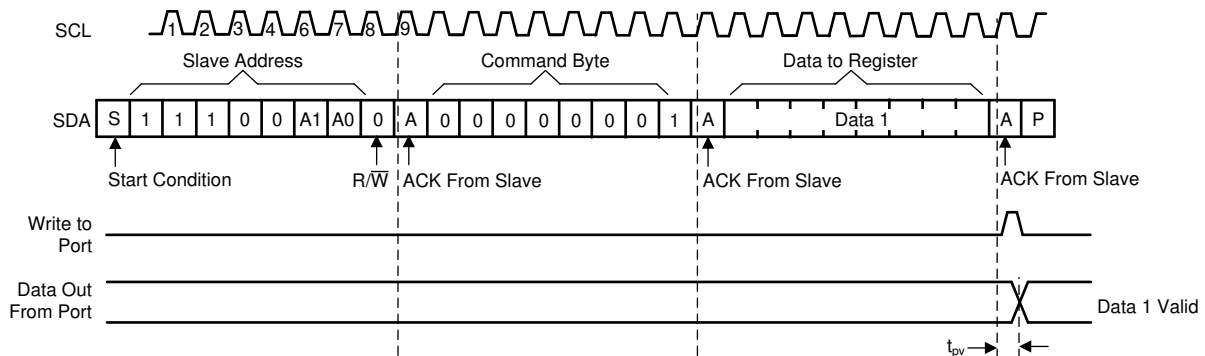

Figure 7-8. Write To Output Port Register

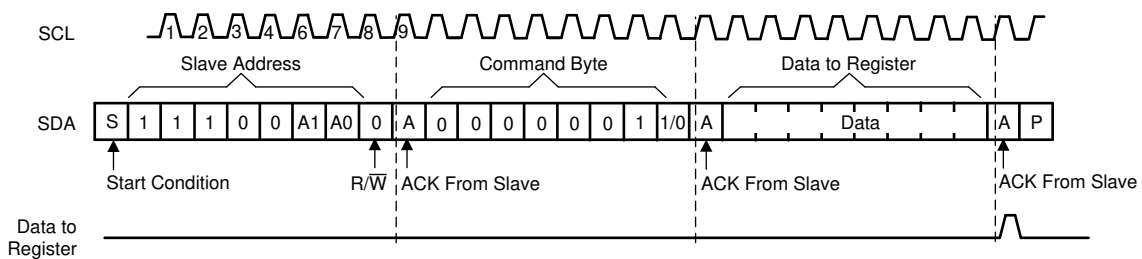

Figure 7-9. Write To Configuration Or Polarity Inversion Registers

7.4.4.2 Reads

The bus master first must send the PCA9538 address with the LSB set to a logic 0 (see Figure 7-6 for device address). The command byte is sent after the address and determines which register is accessed. After a restart, the device address is sent again but, this time, the LSB is set to a logic 1. Data from the register defined by the command byte then is sent by the PCA9538 (see Figure 7-10 and Figure 7-11). After a restart, the value of the register defined by the command byte matches the register being accessed when the restart occurred. Data is clocked into the register on the rising edge of the ACK clock pulse. There is no limitation on the number of data bytes received in one read transmission, but when the final byte is received, the bus master must not acknowledge the data.

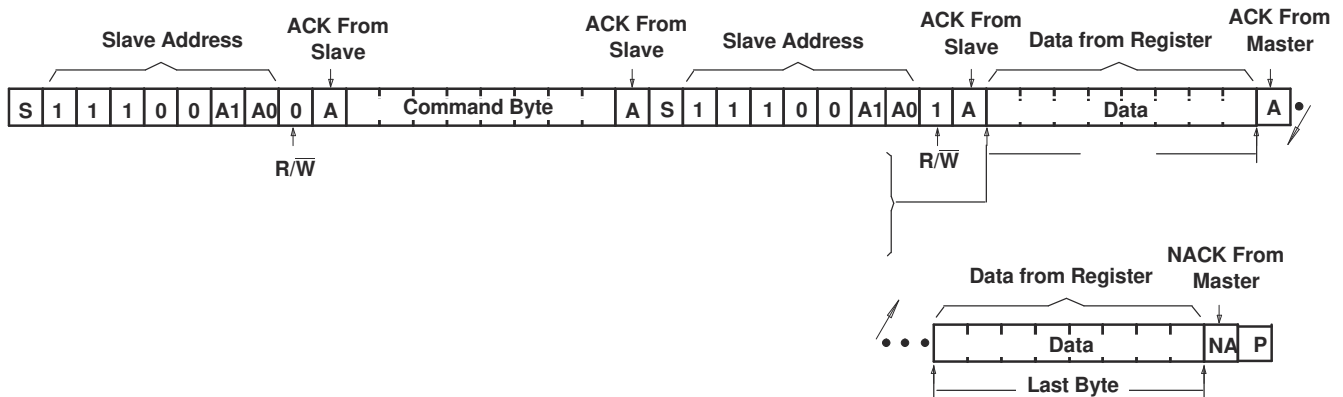
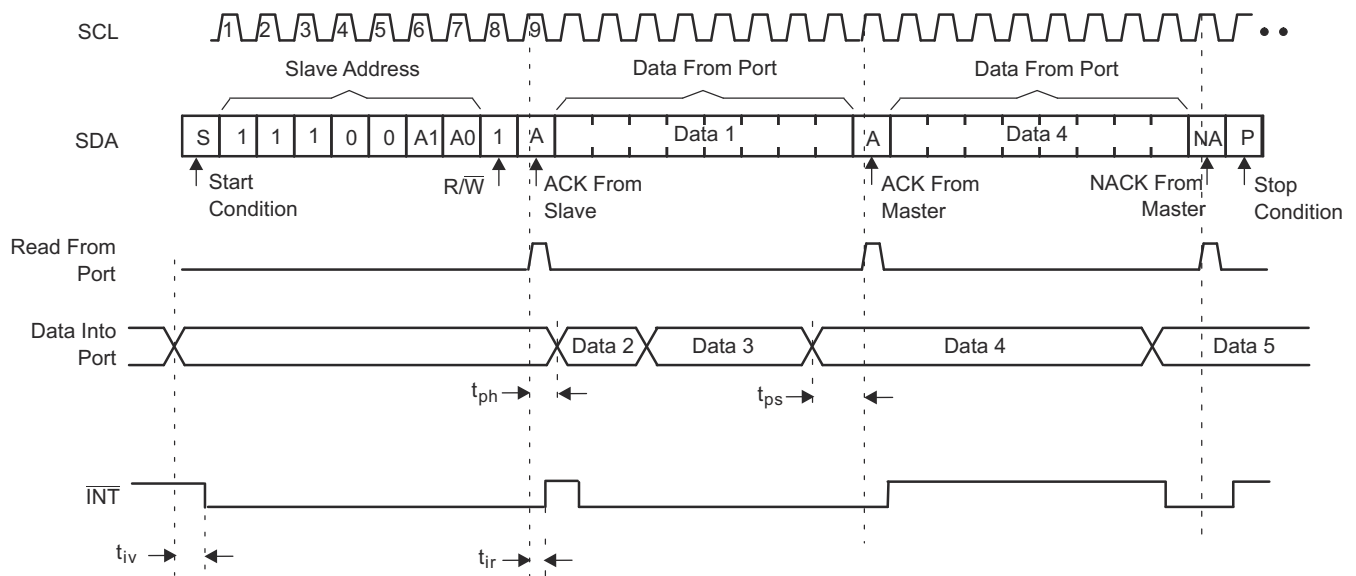

Figure 7-10. Read From Register



- A. This figure assumes the command byte has previously been programmed with 00h.
- B. Transfer of data can be stopped at any moment by a Stop condition.
- C. This figure eliminates the command byte transfer, a restart, and slave address call between the initial slave address call and actual data transfer from the P port. See Figure 7-10 for these details.

Figure 7-11. Read From Input Port Register

8 Application Information Disclaimer

Note

Information in the following applications sections is not part of the TI component specification, and TI does not warrant its accuracy or completeness. TI's customers are responsible for determining suitability of components for their purposes, as well as validating and testing their design implementation to confirm system functionality.

8.1 Application Information Disclaimer

Note

Information in the following applications sections is not part of the TI component specification, and TI does not warrant its accuracy or completeness. TI's customers are responsible for determining suitability of components for their purposes, as well as validating and testing their design implementation to confirm system functionality.

8.2 Typical Application

Figure 8-1 shows an application in which the PCA9538 can be used.

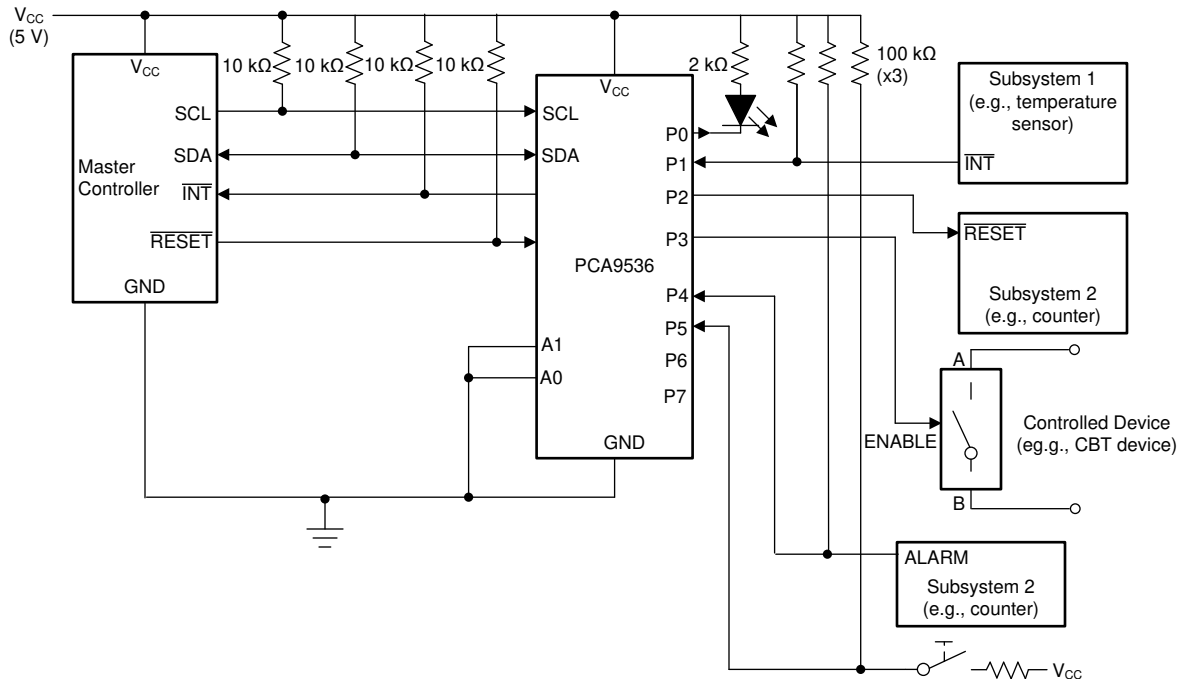

- A. Device address is configured as 1110000 for this example.
- B. P0, P2, and P3 are configured as outputs.
- C. P1, P4, and P5 are configured as inputs.
- D. P6 and P7 are not used and must be configured as outputs.

Figure 8-1. Typical Application

8.2.1 Detailed Design Procedure

8.2.1.1 Minimizing I_{CC} When I/Os Control Leds

When the I/Os are used to control LEDs, normally they are connected to V_{CC} through a resistor as shown in Figure 8-1. The LED acts as a diode, so when the LED is off, the I/O V_{IN} is about 1.2 V less than V_{CC} . I_{CC} in Electrical Characteristics shows how I_{CC} increases as V_{IN} becomes lower than V_{CC} .

For battery-powered applications, it is essential that the voltage of I/O pins is greater than or equal to V_{CC} when the LED is off to minimize current consumption. [Figure 8-2](#) shows a high-value resistor in parallel with the LED. [Figure 8-3](#) shows V_{CC} less than the LED supply voltage by at least 1.2 V. Both of these methods maintain the I/O V_{IN} at or above V_{CC} and prevents additional supply current consumption when the LED is off.

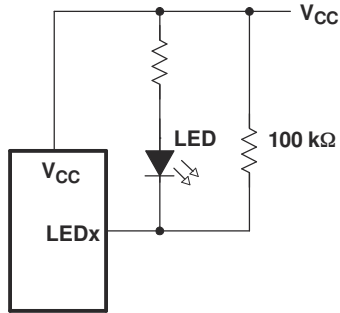

Figure 8-2. High-Value Resistor in Parallel with Led

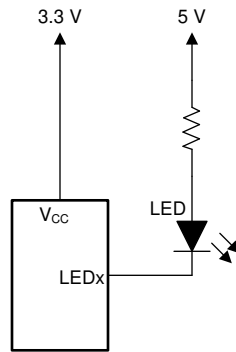

Figure 8-3. Device Supplied by a Lower Voltage

9 Power Supply Recommendations

9.1 Power-On Reset Requirements

In the event of a glitch or data corruption, PCA9538 can be reset to its default conditions by using the power-on reset feature. Power-on reset requires that the device go through a power cycle to be completely reset. This reset also happens when the device is powered on for the first time in an application.

The two types of power-on reset are shown in [Figure 9-1](#) and [Figure 9-2](#).

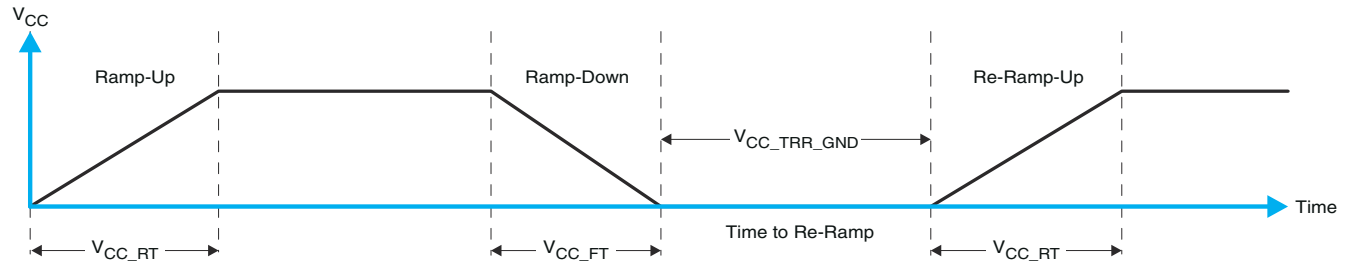

Figure 9-1. V_{CC} Is Lowered Below 0.2 V Or 0 V And Then Ramped Up To V_{CC}

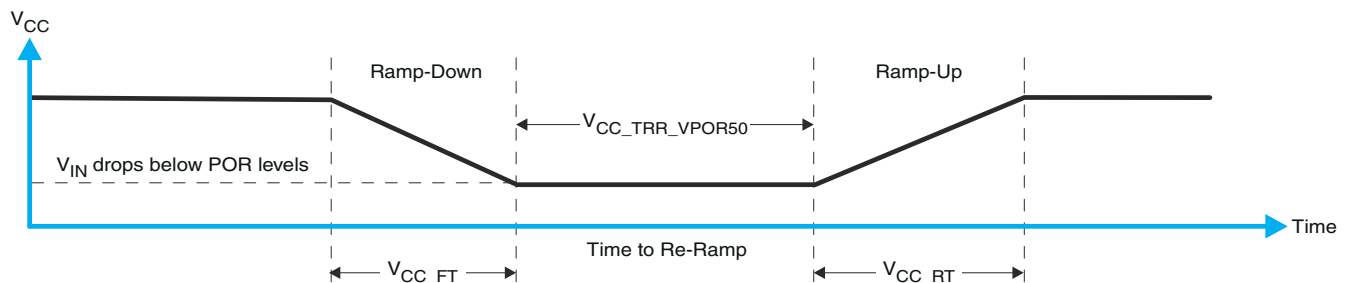

Figure 9-2. V_{CC} Is Lowered Below The Por Threshold, Then Ramped Back Up To V_{CC}

[Table 9-1](#) specifies the performance of the power-on reset feature for PCA9538 for both types of power-on reset.

Table 9-1. Recommended Supply Sequencing And Ramp Rates ⁽¹⁾

PARAMETER			MIN	TYP	MAX	UNIT
V_{CC_FT}	Fall rate	See Figure 9-1	1		100	ms
V_{CC_RT}	Rise rate	See Figure 9-1	0.01		100	ms
$V_{CC_TRR_GND}$	Time to re-ramp (when V_{CC} drops to GND)	See Figure 9-1	0.001			ms
$V_{CC_TRR_POR50}$	Time to re-ramp (when V_{CC} drops to $V_{POR_MIN} - 50$ mV)	See Figure 9-2	0.001			ms
V_{CC_GH}	Level that V_{CCP} can glitch down to, but not cause a functional disruption when $V_{CCX_GW} = 1$ μ s	See Figure 9-3			1.2	V
V_{CC_GW}	Glitch width that will not cause a functional disruption when $V_{CCX_GH} = 0.5 \times V_{CCX}$	See Figure 9-3				μ s
V_{PORF}	Voltage trip point of POR on falling V_{CC}		0.767		1.144	V
V_{PORR}	Voltage trip point of POR on rising V_{CC}		1.033		1.428	V

(1) $T_A = -40^\circ\text{C}$ to 85°C (unless otherwise noted)

Glitches in the power supply can also affect the power-on reset performance of this device. The glitch width (V_{CC_GW}) and height (V_{CC_GH}) are dependent on each other. The bypass capacitance, source impedance, and the device impedance are factors that affect power-on reset performance. [Figure 9-3](#) and [Table 9-1](#) provide more information on how to measure these specifications.

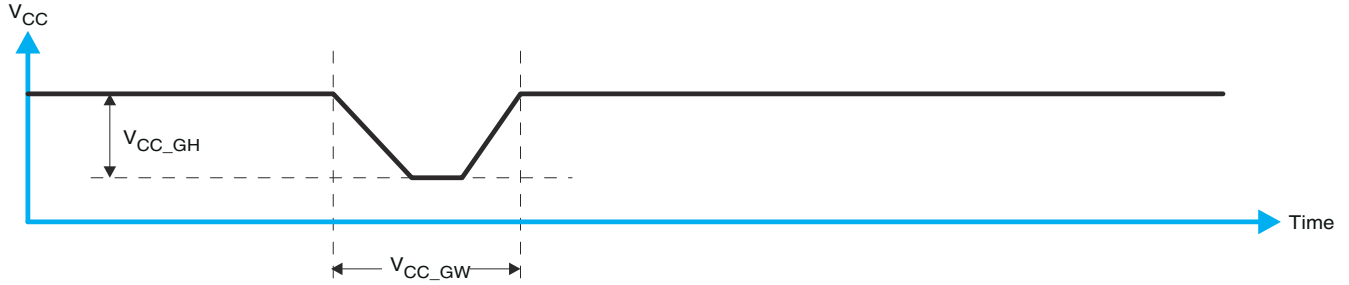

Figure 9-3. Glitch Width And Glitch Height

V_{POR} is critical to the power-on reset. V_{POR} is the voltage level at which the reset condition is released and all the registers and the I²C/SMBus state machine are initialized to their default states. The value of V_{POR} differs based on the V_{CC} being lowered to or from 0. Figure 9-4 and Table 9-1 provide more details on this specification.

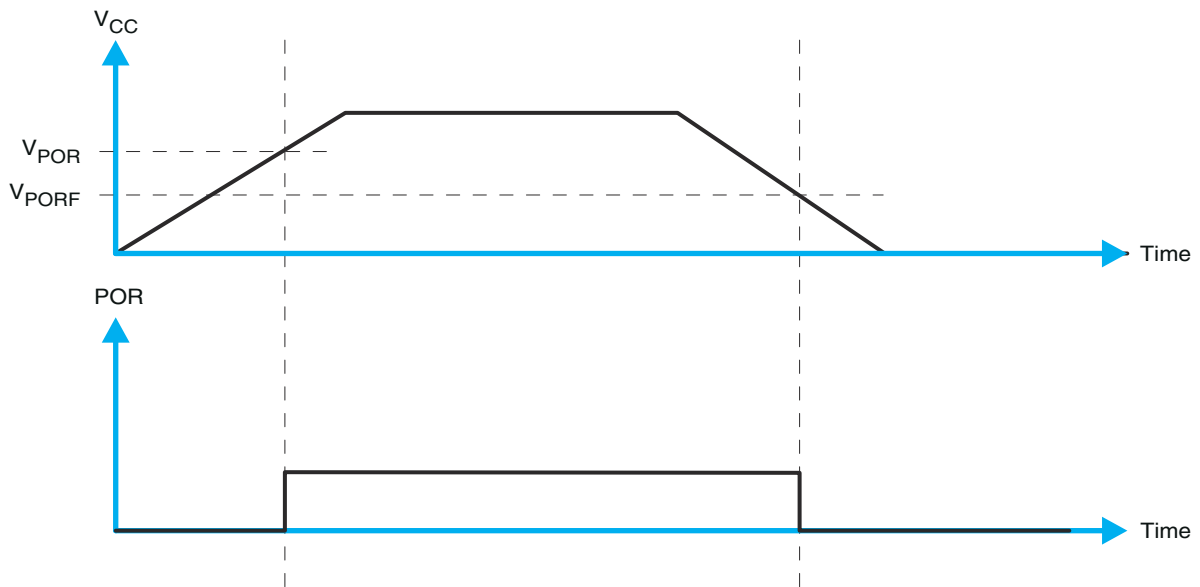

Figure 9-4. V_{POR}

10 Device and Documentation Support

10.1 Receiving Notification of Documentation Updates

To receive notification of documentation updates, navigate to the device product folder on ti.com. Click on *Subscribe to updates* to register and receive a weekly digest of any product information that has changed. For change details, review the revision history included in any revised document.

10.2 Support Resources

TI E2E™ [support forums](#) are an engineer's go-to source for fast, verified answers and design help — straight from the experts. Search existing answers or ask your own question to get the quick design help you need.

Linked content is provided "AS IS" by the respective contributors. They do not constitute TI specifications and do not necessarily reflect TI's views; see TI's [Terms of Use](#).

10.3 Trademarks

TI E2E™ is a trademark of Texas Instruments.

All trademarks are the property of their respective owners.

10.4 Electrostatic Discharge Caution



This integrated circuit can be damaged by ESD. Texas Instruments recommends that all integrated circuits be handled with appropriate precautions. Failure to observe proper handling and installation procedures can cause damage.

ESD damage can range from subtle performance degradation to complete device failure. Precision integrated circuits may be more susceptible to damage because very small parametric changes could cause the device not to meet its published specifications.

10.5 Glossary

[TI Glossary](#) This glossary lists and explains terms, acronyms, and definitions.

11 Mechanical, Packaging, and Orderable Information

The following pages include mechanical, packaging, and orderable information. This information is the most current data available for the designated devices. This data is subject to change without notice and revision of this document. For browser-based versions of this data sheet, refer to the left-hand navigation.

PACKAGING INFORMATION

Orderable Device	Status (1)	Package Type	Package Drawing	Pins	Package Qty	Eco Plan (2)	Lead finish/ Ball material (6)	MSL Peak Temp (3)	Op Temp (°C)	Device Marking (4/5)	Samples
PCA9538DGVR	ACTIVE	TVSOP	DGV	16	2000	RoHS & Green	NIPDAU	Level-1-260C-UNLIM	-40 to 85	PD538	Samples
PCA9538DW	ACTIVE	SOIC	DW	16	40	RoHS & Green	NIPDAU	Level-1-260C-UNLIM	-40 to 85	PCA9538	Samples
PCA9538DWR	ACTIVE	SOIC	DW	16	2000	RoHS & Green	NIPDAU	Level-1-260C-UNLIM	-40 to 85	PCA9538	Samples
PCA9538PWR	ACTIVE	TSSOP	PW	16	2000	RoHS & Green	NIPDAU	Level-1-260C-UNLIM	-40 to 85	PD538	Samples

(1) The marketing status values are defined as follows:

ACTIVE: Product device recommended for new designs.

LIFEBUY: TI has announced that the device will be discontinued, and a lifetime-buy period is in effect.

NRND: Not recommended for new designs. Device is in production to support existing customers, but TI does not recommend using this part in a new design.

PREVIEW: Device has been announced but is not in production. Samples may or may not be available.

OBSELETE: TI has discontinued the production of the device.

(2) **RoHS:** TI defines "RoHS" to mean semiconductor products that are compliant with the current EU RoHS requirements for all 10 RoHS substances, including the requirement that RoHS substance do not exceed 0.1% by weight in homogeneous materials. Where designed to be soldered at high temperatures, "RoHS" products are suitable for use in specified lead-free processes. TI may reference these types of products as "Pb-Free".

RoHS Exempt: TI defines "RoHS Exempt" to mean products that contain lead but are compliant with EU RoHS pursuant to a specific EU RoHS exemption.

Green: TI defines "Green" to mean the content of Chlorine (Cl) and Bromine (Br) based flame retardants meet JS709B low halogen requirements of <=1000ppm threshold. Antimony trioxide based flame retardants must also meet the <=1000ppm threshold requirement.

(3) MSL, Peak Temp. - The Moisture Sensitivity Level rating according to the JEDEC industry standard classifications, and peak solder temperature.

(4) There may be additional marking, which relates to the logo, the lot trace code information, or the environmental category on the device.

(5) Multiple Device Markings will be inside parentheses. Only one Device Marking contained in parentheses and separated by a "-" will appear on a device. If a line is indented then it is a continuation of the previous line and the two combined represent the entire Device Marking for that device.

(6) Lead finish/Ball material - Orderable Devices may have multiple material finish options. Finish options are separated by a vertical ruled line. Lead finish/Ball material values may wrap to two lines if the finish value exceeds the maximum column width.

Important Information and Disclaimer:The information provided on this page represents TI's knowledge and belief as of the date that it is provided. TI bases its knowledge and belief on information provided by third parties, and makes no representation or warranty as to the accuracy of such information. Efforts are underway to better integrate information from third parties. TI has taken and

continues to take reasonable steps to provide representative and accurate information but may not have conducted destructive testing or chemical analysis on incoming materials and chemicals. TI and TI suppliers consider certain information to be proprietary, and thus CAS numbers and other limited information may not be available for release.

In no event shall TI's liability arising out of such information exceed the total purchase price of the TI part(s) at issue in this document sold by TI to Customer on an annual basis.

TAPE AND REEL INFORMATION

QUADRANT ASSIGNMENTS FOR PIN 1 ORIENTATION IN TAPE

*All dimensions are nominal

Device	Package Type	Package Drawing	Pins	SPQ	Reel Diameter (mm)	Reel Width W1 (mm)	A0 (mm)	B0 (mm)	K0 (mm)	P1 (mm)	W (mm)	Pin1 Quadrant
PCA9538DGVR	TVSOP	DGV	16	2000	330.0	12.4	6.8	4.0	1.6	8.0	12.0	Q1
PCA9538DWR	SOIC	DW	16	2000	330.0	16.4	10.75	10.7	2.7	12.0	16.0	Q1
PCA9538PWR	TSSOP	PW	16	2000	330.0	12.4	6.9	5.6	1.6	8.0	12.0	Q1
PCA9538PWR	TSSOP	PW	16	2000	330.0	12.4	6.9	5.6	1.6	8.0	12.0	Q1

TAPE AND REEL BOX DIMENSIONS



*All dimensions are nominal

Device	Package Type	Package Drawing	Pins	SPQ	Length (mm)	Width (mm)	Height (mm)
PCA9538DGVR	TVSOP	DGV	16	2000	356.0	356.0	35.0
PCA9538DWR	SOIC	DW	16	2000	350.0	350.0	43.0
PCA9538PWR	TSSOP	PW	16	2000	356.0	356.0	35.0
PCA9538PWR	TSSOP	PW	16	2000	356.0	356.0	35.0

TUBE

*All dimensions are nominal

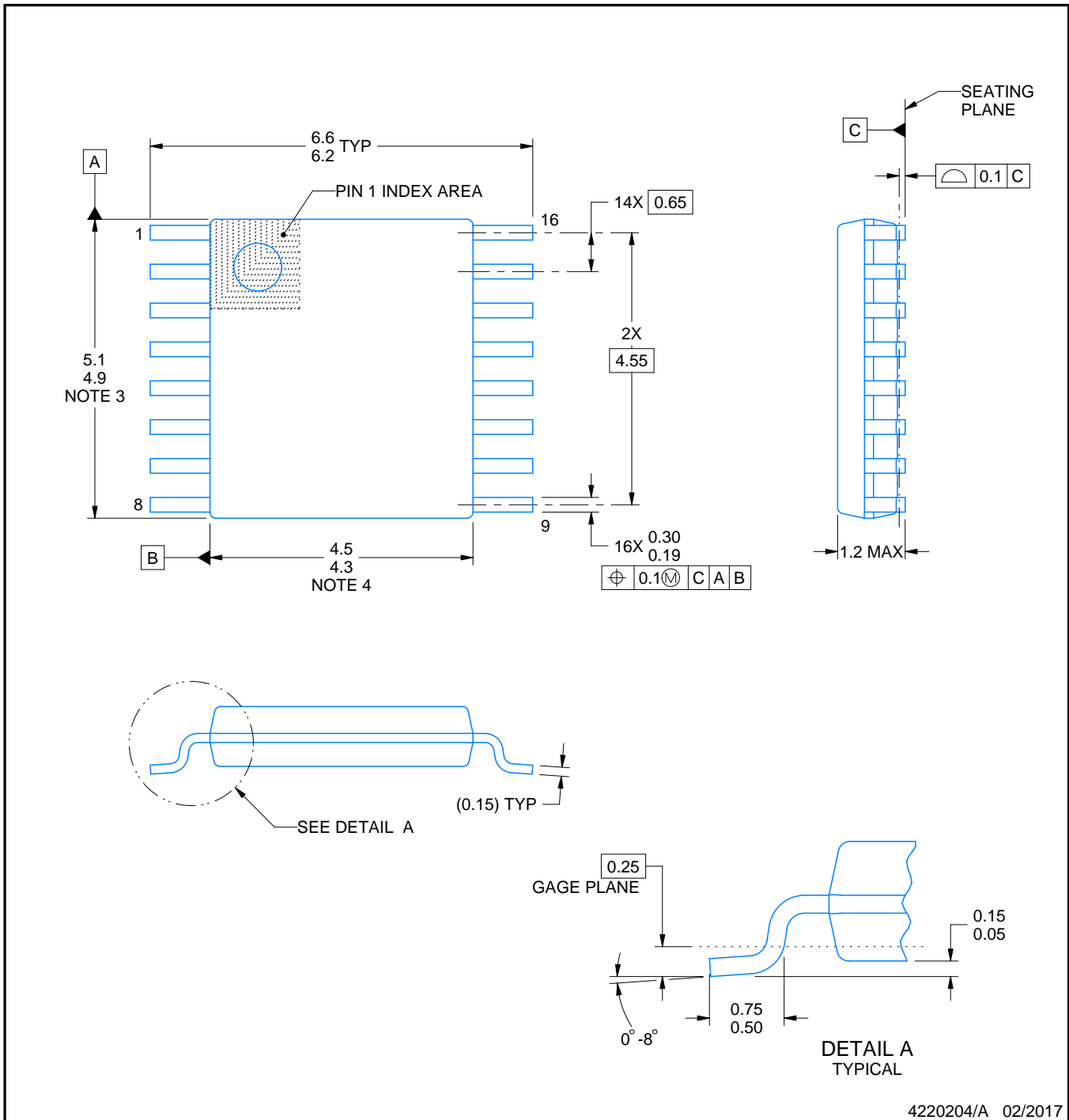
Device	Package Name	Package Type	Pins	SPQ	L (mm)	W (mm)	T (μm)	B (mm)
PCA9538DW	DW	SOIC	16	40	506.98	12.7	4826	6.6



4220204/A 02/2017

NOTES:

1. All linear dimensions are in millimeters. Any dimensions in parenthesis are for reference only. Dimensioning and tolerancing per ASME Y14.5M.
2. This drawing is subject to change without notice.
3. This dimension does not include mold flash, protrusions, or gate burrs. Mold flash, protrusions, or gate burrs shall not exceed 0.15 mm per side.
4. This dimension does not include interlead flash. Interlead flash shall not exceed 0.25 mm per side.
5. Reference JEDEC registration MO-153.

EXAMPLE BOARD LAYOUT

PW0016A

TSSOP - 1.2 mm max height

SMALL OUTLINE PACKAGE



LAND PATTERN EXAMPLE
EXPOSED METAL SHOWN
SCALE: 10X



SOLDER MASK DETAILS

4220204/A 02/2017

NOTES: (continued)

- 6. Publication IPC-7351 may have alternate designs.
- 7. Solder mask tolerances between and around signal pads can vary based on board fabrication site.

EXAMPLE STENCIL DESIGN

PW0016A

TSSOP - 1.2 mm max height

SMALL OUTLINE PACKAGE

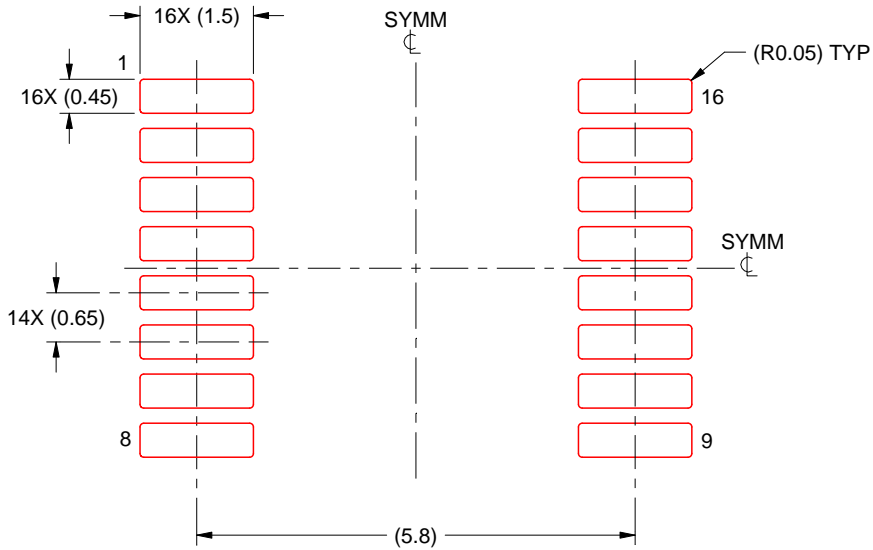

SOLDER PASTE EXAMPLE
BASED ON 0.125 mm THICK STENCIL
SCALE: 10X

4220204/A 02/2017

NOTES: (continued)

8. Laser cutting apertures with trapezoidal walls and rounded corners may offer better paste release. IPC-7525 may have alternate design recommendations.
9. Board assembly site may have different recommendations for stencil design.

GENERIC PACKAGE VIEW

DW 16

SOIC - 2.65 mm max height

7.5 x 10.3, 1.27 mm pitch

SMALL OUTLINE INTEGRATED CIRCUIT

This image is a representation of the package family, actual package may vary.
Refer to the product data sheet for package details.

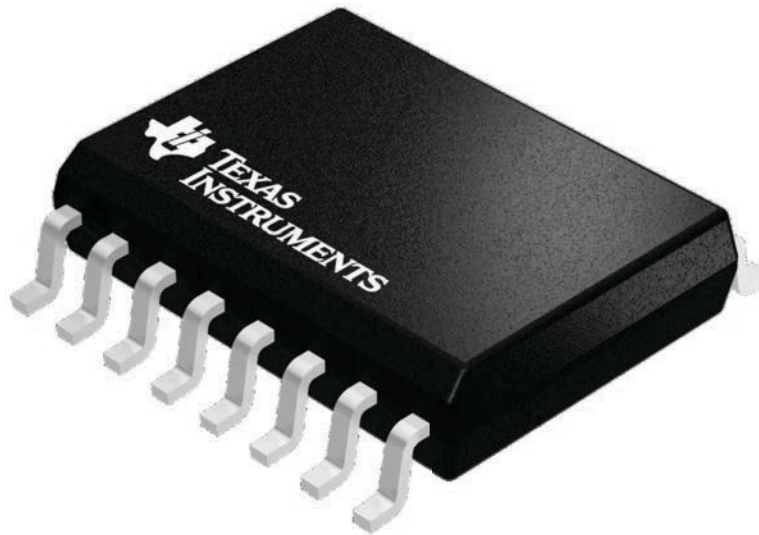

4224780/A

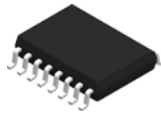

DW0016A

PACKAGE OUTLINE SOIC - 2.65 mm max height

SOIC

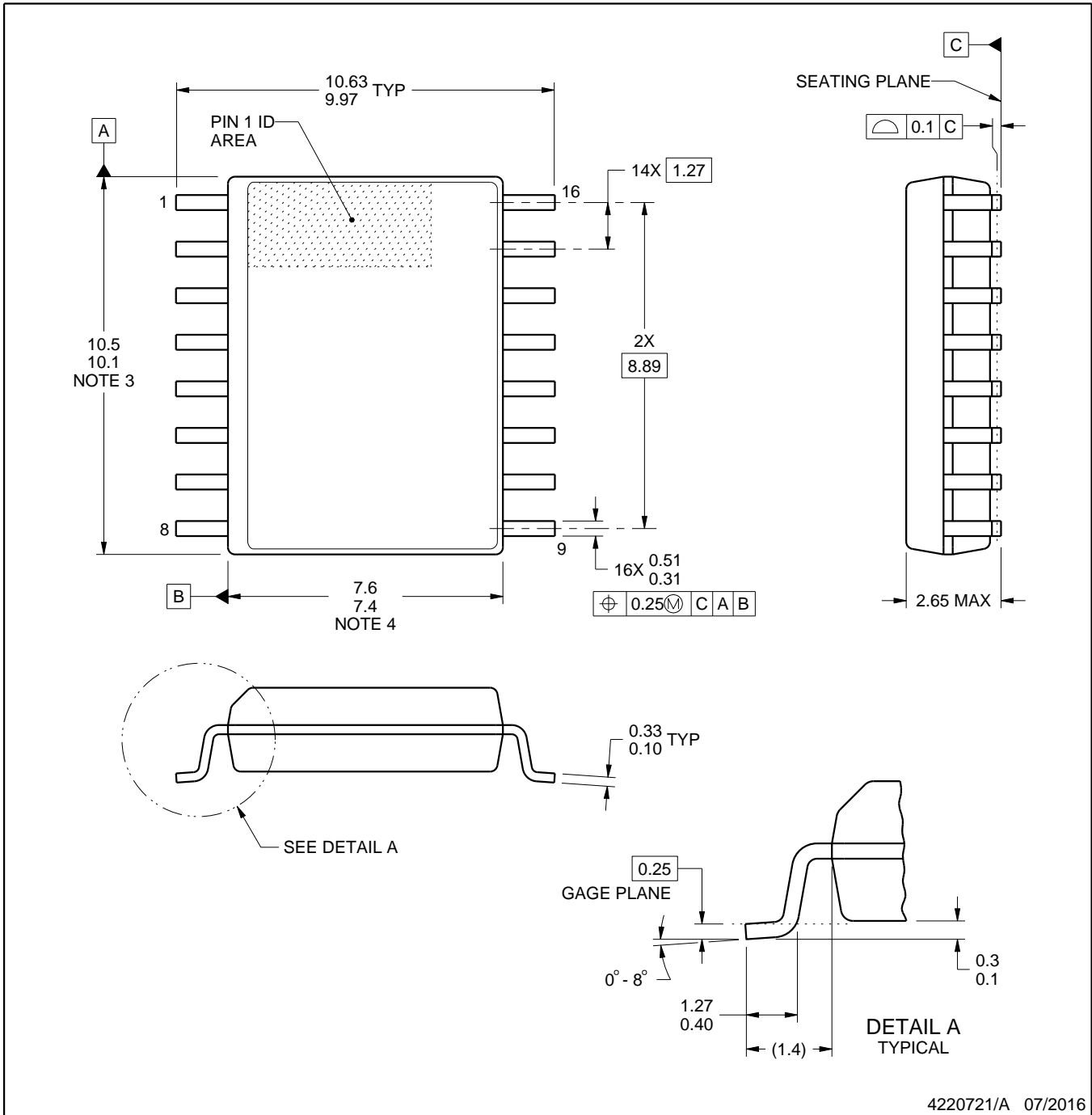

4220721/A 07/2016

NOTES:

1. All linear dimensions are in millimeters. Dimensions in parenthesis are for reference only. Dimensioning and tolerancing per ASME Y14.5M.
2. This drawing is subject to change without notice.
3. This dimension does not include mold flash, protrusions, or gate burrs. Mold flash, protrusions, or gate burrs shall not exceed 0.15 mm, per side.
4. This dimension does not include interlead flash. Interlead flash shall not exceed 0.25 mm, per side.
5. Reference JEDEC registration MS-013.

EXAMPLE BOARD LAYOUT

DW0016A

SOIC - 2.65 mm max height

SOIC

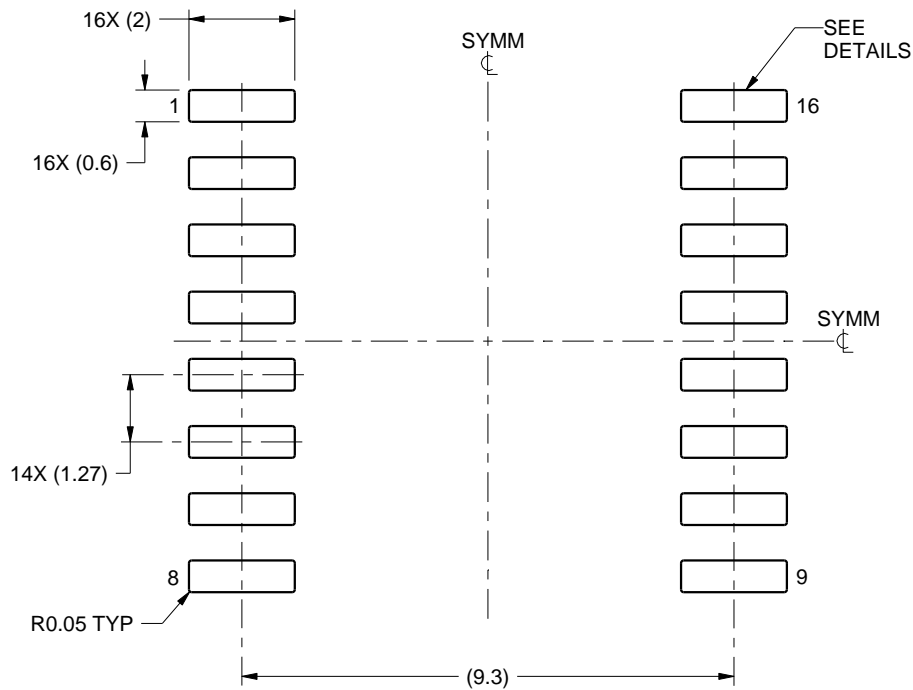

LAND PATTERN EXAMPLE
SCALE:7X

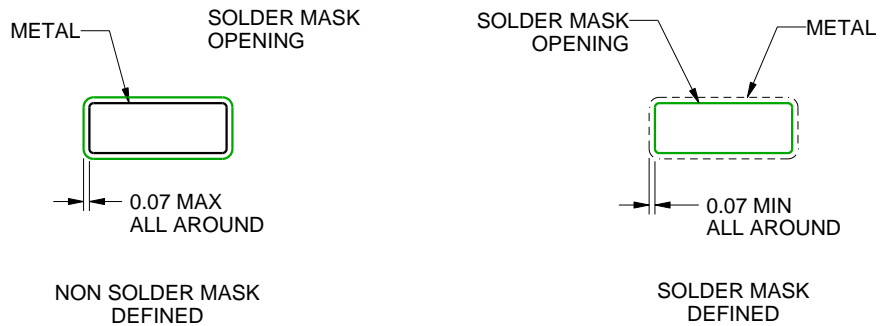

SOLDER MASK DETAILS

4220721/A 07/2016

NOTES: (continued)

6. Publication IPC-7351 may have alternate designs.

7. Solder mask tolerances between and around signal pads can vary based on board fabrication site.

EXAMPLE STENCIL DESIGN

DW0016A

SOIC - 2.65 mm max height

SOIC

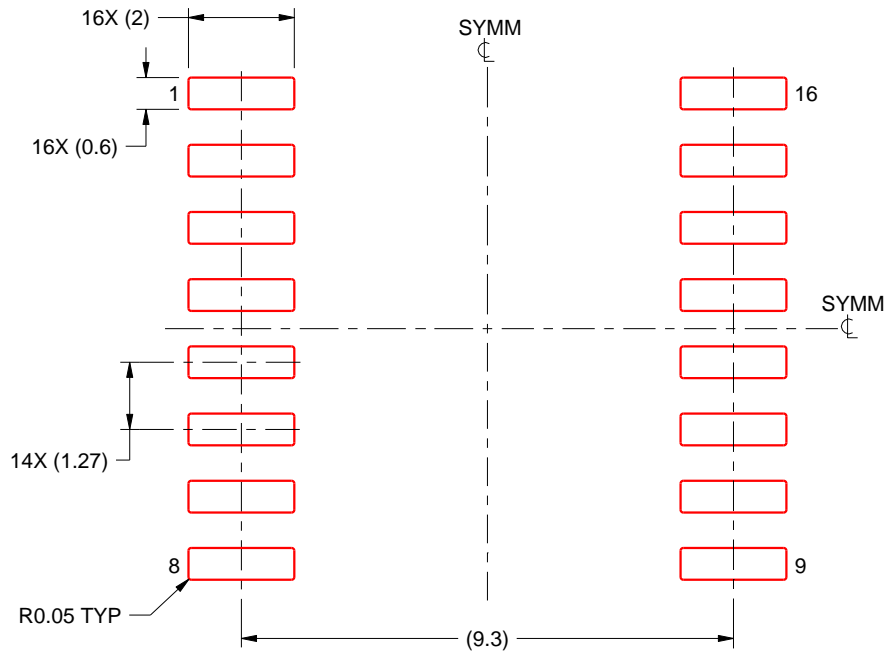

SOLDER PASTE EXAMPLE
BASED ON 0.125 mm THICK STENCIL
SCALE:7X

4220721/A 07/2016

NOTES: (continued)

8. Laser cutting apertures with trapezoidal walls and rounded corners may offer better paste release. IPC-7525 may have alternate design recommendations.
9. Board assembly site may have different recommendations for stencil design.

IMPORTANT NOTICE AND DISCLAIMER

TI PROVIDES TECHNICAL AND RELIABILITY DATA (INCLUDING DATA SHEETS), DESIGN RESOURCES (INCLUDING REFERENCE DESIGNS), APPLICATION OR OTHER DESIGN ADVICE, WEB TOOLS, SAFETY INFORMATION, AND OTHER RESOURCES "AS IS" AND WITH ALL FAULTS, AND DISCLAIMS ALL WARRANTIES, EXPRESS AND IMPLIED, INCLUDING WITHOUT LIMITATION ANY IMPLIED WARRANTIES OF MERCHANTABILITY, FITNESS FOR A PARTICULAR PURPOSE OR NON-INFRINGEMENT OF THIRD PARTY INTELLECTUAL PROPERTY RIGHTS.

These resources are intended for skilled developers designing with TI products. You are solely responsible for (1) selecting the appropriate TI products for your application, (2) designing, validating and testing your application, and (3) ensuring your application meets applicable standards, and any other safety, security, regulatory or other requirements.

These resources are subject to change without notice. TI grants you permission to use these resources only for development of an application that uses the TI products described in the resource. Other reproduction and display of these resources is prohibited. No license is granted to any other TI intellectual property right or to any third party intellectual property right. TI disclaims responsibility for, and you will fully indemnify TI and its representatives against, any claims, damages, costs, losses, and liabilities arising out of your use of these resources.

TI's products are provided subject to [TI's Terms of Sale](#) or other applicable terms available either on [ti.com](https://www.ti.com) or provided in conjunction with such TI products. TI's provision of these resources does not expand or otherwise alter TI's applicable warranties or warranty disclaimers for TI products.

TI objects to and rejects any additional or different terms you may have proposed.

Mailing Address: Texas Instruments, Post Office Box 655303, Dallas, Texas 75265
Copyright © 2024, Texas Instruments Incorporated

Looking for pricing, stock, or lifecycle information?

Click below to explore more details on WIN SOURCE:

 [View PCA9538PWR on WIN SOURCE](#)

 [Texas Instruments](#) Information

Optimize Your Supply Chain with WIN SOURCE Solutions

-  Global Sourcing Solution
-  Obsolete Management
-  Cost Control Management
-  Shortage Management
-  Alternative Solution
-  Excess Inventory Management