



**THE DATASHEET OF
PCA9538DBR**



PCA9538 Remote 8-Bit I²C AND SMBus Low-power I/O Expander With Interrupt Output, Reset, and Configuration Registers

1 Features

- Low Standby Current Consumption of 1 μ A Max
- I²C to Parallel Port Expander
- Open-Drain Active-Low Interrupt Output
- Active-Low Reset Input
- Operating Power-Supply Voltage Range of 2.3 V to 5.5 V
- 5-V Tolerant I/O Ports
- 400-kHz Fast I²C Bus
- Two Hardware Address Pins Allow up to Four Devices on the I²C/SMBus
- Input/Output Configuration Register
- Polarity Inversion Register
- Power-Up With All Channels Configured as Inputs
- No Glitch on Power Up
- Noise Filter on SCL/SDA Inputs
- Latched Outputs With High-Current Drive Maximum Capability for Directly Driving LEDs
- Latch-Up Performance Exceeds 100 mA Per JESD 78, Class II
- ESD Protection Exceeds JESD 22
 - 2000-V Human-Body Model (A114-A)
 - 200-V Machine Model (A115-A)
 - 1000-V Charged-Device Model (C101)

2 Description

This 8-bit I/O expander for the two-line bidirectional bus (I²C) is designed for 2.3-V to 5.5-V V_{CC} operation. It provides general-purpose remote I/O expansion for most microcontroller families via the I²C interface [serial clock (SCL), serial data (SDA)].

The PCA9538 consists of one 8-bit Configuration (input or output selection), Input Port, Output Port, and Polarity Inversion (active high or active low) registers. At power on, the I/Os are configured as inputs. However, the system master can enable the I/Os as either inputs or outputs by writing to the I/O configuration bits. The data for each input or output is kept in the corresponding Input Port or Output Port register. The polarity of the Input Port register can be inverted with the Polarity Inversion register. All registers can be read by the system master.

The system master can reset the PCA9538 in the event of a timeout or other improper operation by asserting a low in the RESET input. The power-on reset puts the registers in their default state and initializes the I²C/SMBus state machine. The RESET pin causes the same reset/initialization to occur without powering down the part.

The PCA9538 open-drain interrupt ($\overline{\text{INT}}$) output is activated when any input state differs from its corresponding Input Port register state and is used to indicate to the system master that an input state has changed.

Device Information⁽¹⁾

| PART NUMBER | PACKAGE | BODY SIZE (NOM) |
|-------------|------------|--------------------|
| TCA6424 | SSOP (16) | 6.20 mm x 5.30 mm |
| | TVSOP (16) | 3.60 mm x 4.40 mm |
| | SOIC (16) | 10.30 mm x 7.50 mm |
| | TSSOP (16) | 5.00 mm x 4.40 mm |

(1) For all available packages, see the orderable addendum at the end of the datasheet.

DB, DBQ, DGV, DW, OR PW PACKAGE
(TOP VIEW)

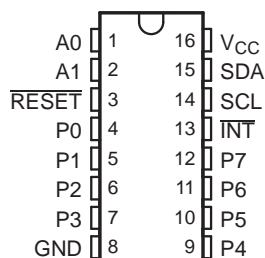

RGV PACKAGE
(TOP VIEW)

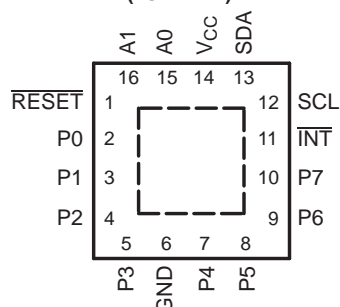

RGT PACKAGE
(TOP VIEW)

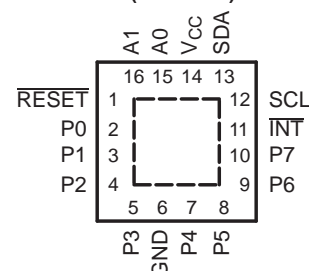

Table of Contents

| | |
|--|--|
| 1 Features 1 2 Description 1 3 Revision History 2 4 Description (Continued) 3 5 Pin Configuration and Functions 3 6 Specifications 4 6.1 Absolute Maximum Ratings 4 6.2 Handling Ratings..... 4 6.3 Recommended Operating Conditions..... 4 6.4 Electrical Characteristics..... 5 6.5 I ² C Interface Timing Requirements..... 6 6.6 $\overline{\text{RESET}}$ Timing Requirements..... 6 6.7 Switching Characteristics 6 6.8 Typical Characteristics..... 7 | 7 Parameter Measurement Information 10 8 Detailed Description 14 8.1 Functional Block Diagram 14 8.2 Device Functional Modes..... 16 8.3 Programming..... 17 9 Application And Implementation 24 9.1 Typical Application 24 10 Power Supply Recommendations 26 10.1 Power-On Reset Errata..... 26 11 Device and Documentation Support 27 11.1 Trademarks 27 11.2 Electrostatic Discharge Caution..... 27 11.3 Glossary..... 27 12 Mechanical, Packaging, and Orderable Information 27 |
|--|--|

3 Revision History

| Changes from Revision E (September 2008) to Revision F | Page |
|--|------|
| • Added $\overline{\text{RESET}}$ Errata section. | 16 |
| • Added Interrupt Errata section | 17 |
| • Power-On Reset Errata section..... | 26 |

4 Description (Continued)

$\overline{\text{INT}}$ can be connected to the interrupt input of a microcontroller. By sending an interrupt signal on this line, the remote I/O can inform the microcontroller if there is incoming data on its ports without having to communicate via the I²C bus. Thus, the PCA9538 can remain a simple slave device.

The device outputs (latched) have high-current drive capability for directly driving LEDs. It has low current consumption.

Two hardware pins (A0 and A1) are used to program and vary the fixed I²C address and allow up to four devices to share the same I²C bus or SMBus.

5 Pin Configuration and Functions

DB, DBQ, DGV, DW, OR PW PACKAGE
(TOP VIEW)

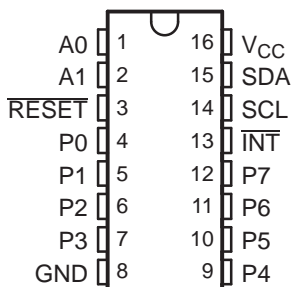

RGV PACKAGE
(TOP VIEW)

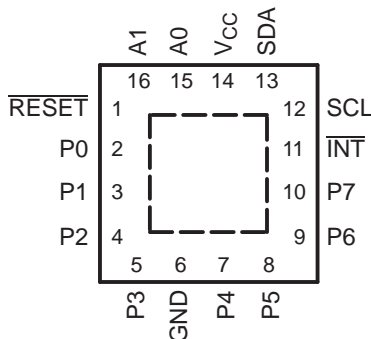

RGT PACKAGE
(TOP VIEW)

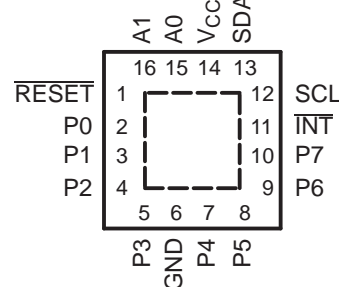

Pin Functions

| NAME | PIN NO. | | DESCRIPTION |
|---------------------------|-----------------------------|------------------|---|
| | DB, DBQ, DGV, DW, PW, TVSOP | RGT OR QFN (RGV) | |
| A0 | 1 | 15 | Address input. Connect directly to V _{CC} or ground. |
| A1 | 2 | 16 | Address input. Connect directly to V _{CC} or ground. |
| $\overline{\text{RESET}}$ | 3 | 1 | Active-low reset input. Connect to V _{CC} through a pullup resistor if no active connection is used. |
| P0 | 4 | 2 | P-port input/output. Push-pull design structure. |
| P1 | 5 | 3 | P-port input/output. Push-pull design structure. |
| P2 | 6 | 4 | P-port input/output. Push-pull design structure. |
| P3 | 7 | 5 | P-port input/output. Push-pull design structure. |
| GND | 8 | 6 | Ground |
| P4 | 9 | 7 | P-port input/output. Push-pull design structure. |
| P5 | 10 | 8 | P-port input/output. Push-pull design structure. |
| P6 | 11 | 9 | P-port input/output. Push-pull design structure. |
| P7 | 12 | 10 | P-port input/output. Push-pull design structure. |
| $\overline{\text{INT}}$ | 13 | 11 | Interrupt output. Connect to V _{CC} through a pullup resistor. |
| SCL | 14 | 12 | Serial clock bus. Connect to V _{CC} through a pullup resistor. |
| SDA | 15 | 13 | Serial data bus. Connect to V _{CC} through a pullup resistor. |
| V _{CC} | 16 | 14 | Supply voltage |

6 Specifications

6.1 Absolute Maximum Ratings⁽¹⁾

over operating free-air temperature range (unless otherwise noted)

| | | MIN | MAX | UNIT |
|-----------------------------|--|--|------|------|
| V _{CC} | Supply voltage range | -0.5 | 6 | V |
| V _I | Input voltage range ⁽²⁾ | -0.5 | 6 | V |
| V _O | Output voltage range ⁽²⁾ | -0.5 | 6 | V |
| I _{IK} | Input clamp current | V _I < 0 | -20 | mA |
| I _{OK} | Output clamp current | V _O < 0 | -20 | mA |
| I _{I_{OK}} | Input/output clamp current | V _O < 0 or V _O > V _{CC} | ±20 | mA |
| I _{OL} | Continuous output low current | V _O = 0 to V _{CC} | 50 | mA |
| I _{OH} | Continuous output high current | V _O = 0 to V _{CC} | -50 | mA |
| I _{CC} | Continuous current through GND | | -250 | mA |
| | Continuous current through V _{CC} | | 160 | |
| θ _{JA} | Package thermal impedance ⁽³⁾ | DB package | 82 | °C/W |
| | | DBQ package | 90 | |
| | | DGV package | 86 | |
| | | DW package | 46 | |
| | | PW package | 88 | |
| | | RGT package | TBD | |
| | | RGV package | TBD | |

- (1) Stresses beyond those listed under "absolute maximum ratings" may cause permanent damage to the device. These are stress ratings only, and functional operation of the device at these or any other conditions beyond those indicated under "recommended operating conditions" is not implied. Exposure to absolute-maximum-rated conditions for extended periods may affect device reliability.
- (2) The input negative-voltage and output voltage ratings may be exceeded if the input and output current ratings are observed.
- (3) The package thermal impedance is calculated in accordance with JESD 51-7.

6.2 Handling Ratings

| | | MIN | MAX | UNIT | |
|--------------------|---------------------------|--|-----|------|---|
| T _{stg} | Storage temperature range | -65 | 150 | °C | |
| V _(ESD) | Electrostatic discharge | Human body model (HBM), per ANSI/ESDA/JEDEC JS-001, all pins ⁽¹⁾ | 0 | 2000 | V |
| | | Charged device model (CDM), per JEDEC specification JESD22-C101, all pins ⁽²⁾ | 0 | 1000 | |

- (1) JEDEC document JEP155 states that 500-V HBM allows safe manufacturing with a standard ESD control process.
- (2) JEDEC document JEP157 states that 250-V CDM allows safe manufacturing with a standard ESD control process.

6.3 Recommended Operating Conditions

over operating free-air temperature range (unless otherwise noted)

| | | MIN | MAX | UNIT | |
|-----------------|--------------------------------|---|-----------------------|-----------------------|---|
| V _{CC} | Supply voltage | 2.3 | 5.5 | V | |
| V _{IH} | High-level input voltage | SCL, SDA | 0.7 × V _{CC} | 5.5 | V |
| | | A0, A1, $\overline{\text{RESET}}$, P7–P0 | 2 | 5.5 | |
| V _{IL} | Low-level input voltage | SCL, SDA | -0.5 | 0.3 × V _{CC} | V |
| | | A0, A1, $\overline{\text{RESET}}$, P7–P0 | -0.5 | 0.8 | |
| I _{OH} | High-level output current | P7–P0 | -10 | mA | |
| I _{OL} | Low-level output current | P7–P0 | 25 | mA | |
| T _A | Operating free-air temperature | -40 | 85 | °C | |

6.4 Electrical Characteristics

over operating free-air temperature range (unless otherwise noted)

| PARAMETER | | TEST CONDITIONS | V _{CC} | MIN | TYP ⁽¹⁾ | MAX | UNIT | |
|------------------|---|---|------------------|------|--------------------|------|------|--|
| V _{IK} | Input diode clamp voltage | I _I = -18 mA | 2.3 V to 5.5 V | -1.2 | | | V | |
| V _{POR} | Power-on reset voltage | V _I = V _{CC} or GND, I _O = 0 | V _{POR} | | 1.5 | 1.65 | V | |
| V _{OH} | P-port high-level output voltage ⁽²⁾ | I _{OH} = -8 mA | 2.3 V | 1.8 | | | V | |
| | | | 3 V | 2.6 | | | | |
| | | | 4.5 V | 4.1 | | | | |
| | | | 4.75 V | 4.1 | | | | |
| | | I _{OH} = -10 mA | 2.3 V | 1.7 | | | | |
| | | | 3 V | 2.5 | | | | |
| | | | 4.5 V | 4 | | | | |
| | | | 4.75 V | 4 | | | | |
| I _{OL} | SDA | V _{OL} = 0.4 V | 2.3 V to 5.5 V | 3 | 8 | | mA | |
| | P port ⁽³⁾ | V _{OL} = 0.5 V | 2.3 V | 8 | 10 | | | |
| | | | 3 V | 8 | 14 | | | |
| | | | 4.5 V | 8 | 17 | | | |
| | | | 4.75 V | 8 | 35 | | | |
| | | V _{OL} = 0.7 V | 2.3 V | 10 | 13 | | | |
| | | | 3 V | 10 | 19 | | | |
| | | | 4.5 V | 10 | 24 | | | |
| | | | 4.75 V | 10 | 45 | | | |
| | INT | V _{OL} = 0.4 V | 2.3 V to 5.5 V | 3 | 10 | | | |
| I _I | SCL, SDA | V _I = V _{CC} or GND | 2.3 V to 5.5 V | | | ±1 | μA | |
| | A0, A1, RESET | | | | | ±1 | | |
| I _{IH} | P port | V _I = V _{CC} | 2.3 V to 5.5 V | | | 1 | μA | |
| I _{IL} | P port | V _I = GND | 2.3 V to 5.5 V | | | -1 | μA | |
| I _{CC} | Operating mode | V _I = V _{CC} or GND, I _O = 0, I/O = inputs, f _{scl} = 400 kHz, No load | 5.5 V | | 104 | 175 | μA | |
| | | | 3.6 V | | 50 | 90 | | |
| | | | 2.7 V | | 20 | 65 | | |
| | | V _I = V _{CC} or GND, I _O = 0, I/O = inputs, f _{scl} = 100 kHz, No load | 5.5 V | | 60 | 150 | | |
| | | | 3.6 V | | 15 | 40 | | |
| | | | 2.7 V | | 8 | 20 | | |
| | Standby mode | V _I = V _{CC} or GND, I _O = 0, I/O = inputs, f _{scl} = 0 kHz, No load | 5.5 V | | 0.25 | 1 | | |
| | | | 3.6 V | | 0.2 | 0.9 | | |
| | | | 2.7 V | | 0.1 | 0.8 | | |
| ΔI _{CC} | Additional current in standby mode | One input at V _{CC} - 0.6 V, Other inputs at V _{CC} or GND | 2.3 V to 5.5 V | | | 1.5 | mA | |
| | | All LED I/Os at V _I = 4.3 V, f _{scl} = 0 kHz | 5.5 V | | | 1 | | |
| C _i | SCL | V _I = V _{CC} or GND | 2.3 V to 5.5 V | | 4 | 5 | pF | |
| C _{io} | SDA | V _{IO} = V _{CC} or GND | 2.3 V to 5.5 V | | 5.5 | 6.5 | pF | |
| | P port | | | | 8 | 9.5 | | |

(1) All typical values are at nominal supply voltage (2.5-V, 3.3-V, or 5-V V_{CC}) and T_A = 25°C.

(2) The total current sourced by all I/Os must be limited to 85 mA.

(3) Each I/O must be externally limited to a maximum of 25 mA, and the P port (P7–P0) must be limited to a maximum current of 200 mA.

6.5 I²C Interface Timing Requirements

 over operating free-air temperature range (unless otherwise noted) (see [Figure 14](#))

| | | STANDARD MODE I ² C BUS | | FAST MODE I ² C BUS | | UNIT | |
|-----------------------|--|--|------|---------------------------------------|-----|------|----|
| | | MIN | MAX | MIN | MAX | | |
| t _{scl} | I ² C clock frequency | 0 | 100 | 0 | 400 | kHz | |
| t _{sch} | I ² C clock high time | 4 | | 0.6 | | μs | |
| t _{scl} | I ² C clock low time | 4.7 | | 1.3 | | μs | |
| t _{sp} | I ² C spike time | | 50 | | 50 | ns | |
| t _{sds} | I ² C serial-data setup time | 250 | | 100 | | ns | |
| t _{sdh} | I ² C serial-data hold time | 0 | | 0 | | ns | |
| t _{icr} | I ² C input rise time | | 1000 | 20 + 0.1C _b ⁽¹⁾ | 300 | ns | |
| t _{icf} | I ² C input fall time | | 300 | 20 + 0.1C _b ⁽¹⁾ | 300 | ns | |
| t _{ocf} | I ² C output fall time | 10-pF to 400-pF bus | 300 | 20 + 0.1C _b ⁽¹⁾ | 300 | ns | |
| t _{buf} | I ² C bus free time between Stop and Start | 4.7 | | 1.3 | | μs | |
| t _{sts} | I ² C Start or repeated Start condition setup | 4.7 | | 0.6 | | μs | |
| t _{sth} | I ² C Start or repeated Start condition hold | 4 | | 0.6 | | μs | |
| t _{sps} | I ² C Stop condition setup | 4 | | 0.6 | | μs | |
| t _{vd(data)} | Valid data time | SCL low to SDA output valid | 300 | 50 | | ns | |
| t _{vd(ack)} | Valid data time of ACK condition | ACK signal from SCL low to SDA (out) low | 0.3 | 3.45 | 0.1 | 0.9 | μs |
| C _b | I ² C bus capacitive load | | 400 | | 400 | ns | |

 (1) C_b = Total capacitance of one bus in pF

6.6 RESET Timing Requirements

over operating free-air temperature range (unless otherwise noted)

| PARAMETER | | STANDARD MODE I ² C BUS | | FAST MODE I ² C BUS | | UNIT |
|--------------------|----------------------|---------------------------------------|-----|-----------------------------------|-----|------|
| | | MIN | MAX | MIN | MAX | |
| t _w | Reset pulse duration | 4 | | 4 | | ns |
| t _{REC} | Reset recovery time | 0 | | 0 | | ns |
| t _{RESET} | Time to reset | 400 | | 400 | | ns |

6.7 Switching Characteristics

 over operating free-air temperature range (unless otherwise noted) (see [Figure 15](#) and [Figure 16](#))

| PARAMETER | FROM (INPUT) | TO (OUTPUT) | STANDARD MODE I ² C BUS | | FAST MODE I ² C BUS | | UNIT |
|-----------------|----------------------------|----------------|---------------------------------------|-----|-----------------------------------|-----|------|
| | | | MIN | MAX | MIN | MAX | |
| t _{iv} | Interrupt valid time | P port | | 4 | | 4 | μs |
| t _{ir} | Interrupt reset delay time | SCL | | 4 | | 4 | μs |
| t _{pv} | Output data valid | SCL | | 200 | | 200 | ns |
| t _{ps} | Input data setup time | P port | 100 | | 100 | | ns |
| t _{ph} | Input data hold time | P port | 1 | | 1 | | μs |

6.8 Typical Characteristics

$T_A = 25^\circ\text{C}$ (unless otherwise noted)

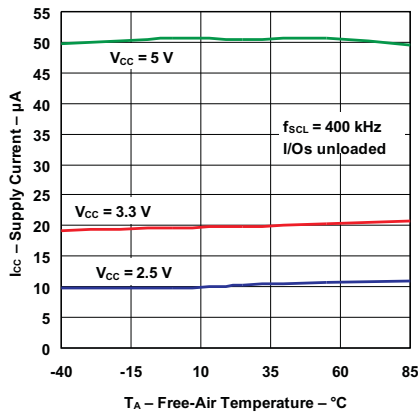

Figure 1. Supply Current vs Temperature

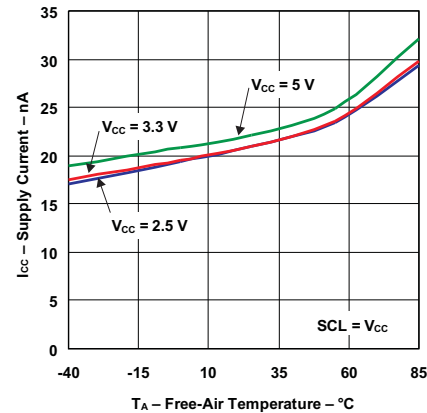

Figure 2. Quiescent Supply Current vs Temperature

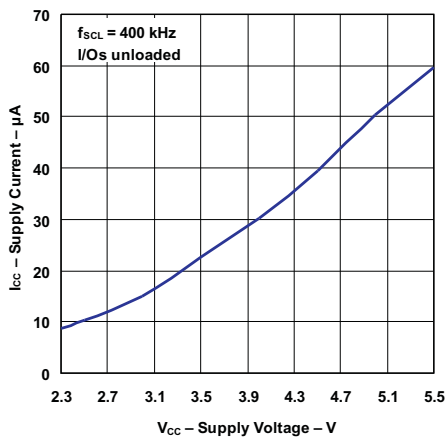

Figure 3. Supply Current vs Supply Voltage

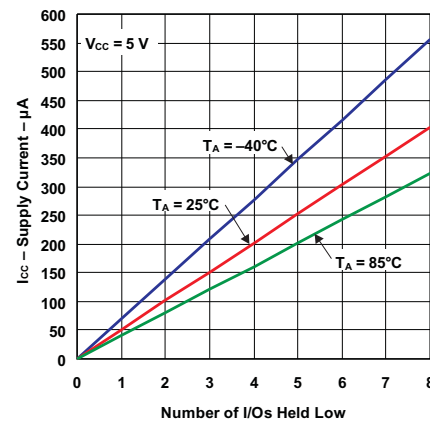

Figure 4. Supply Current vs Number Of I/Os Held Low

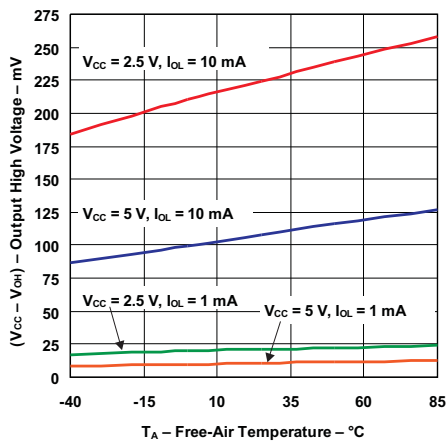

Figure 5. I/O Output Low Voltage vs Temperature

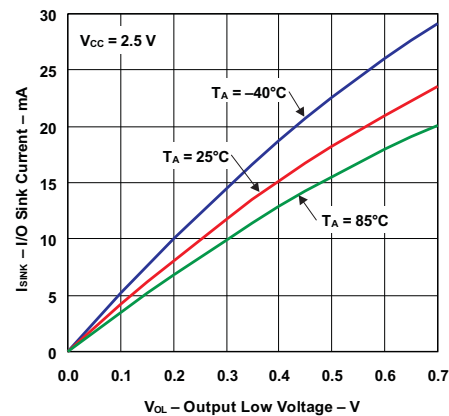

Figure 6. I/O Sink Current vs Output Low Voltage

Typical Characteristics (continued)

$T_A = 25^\circ\text{C}$ (unless otherwise noted)

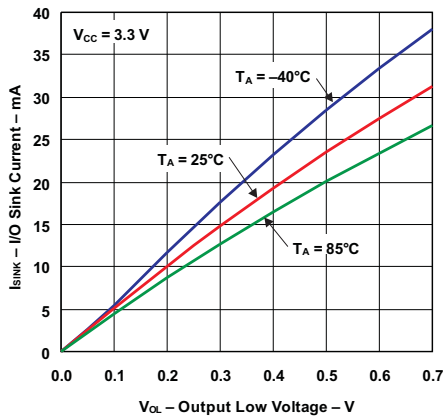

Figure 7. I/O Sink Current vs Output Low Voltage

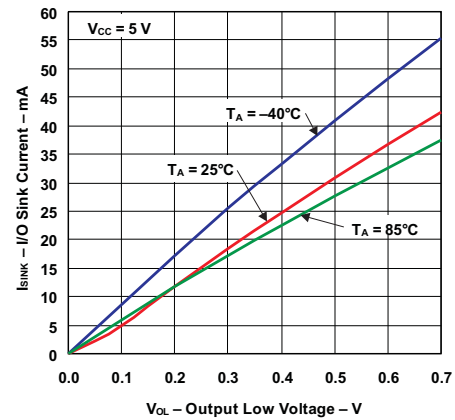

Figure 8. I/O Sink Current vs Output Low Voltage

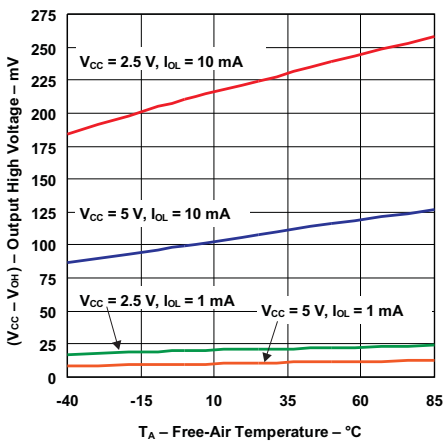

Figure 9. I/O Output High Voltage vs Temperature

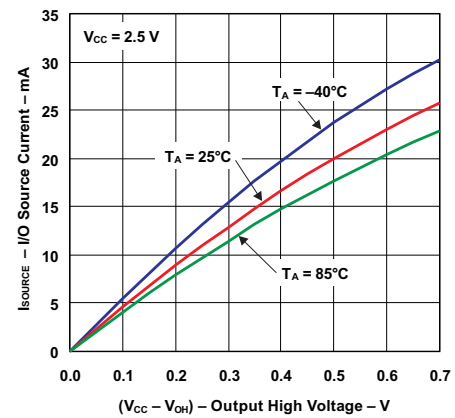

Figure 10. I/O Source Current vs Output High Voltage

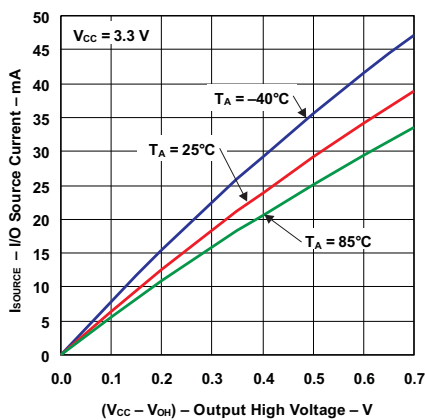

Figure 11. I/O Source Current vs Output High Voltage

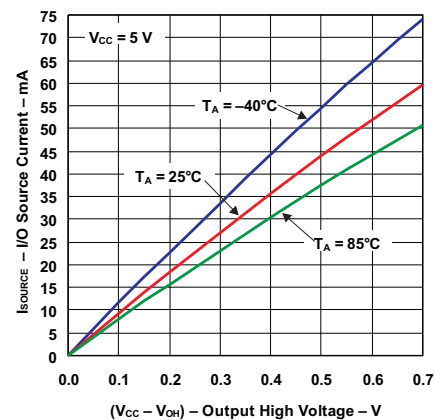

Figure 12. I/O Source Current vs Output High Voltage

Typical Characteristics (continued)

$T_A = 25^\circ\text{C}$ (unless otherwise noted)

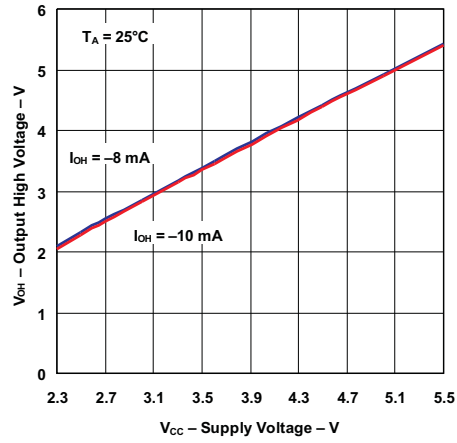
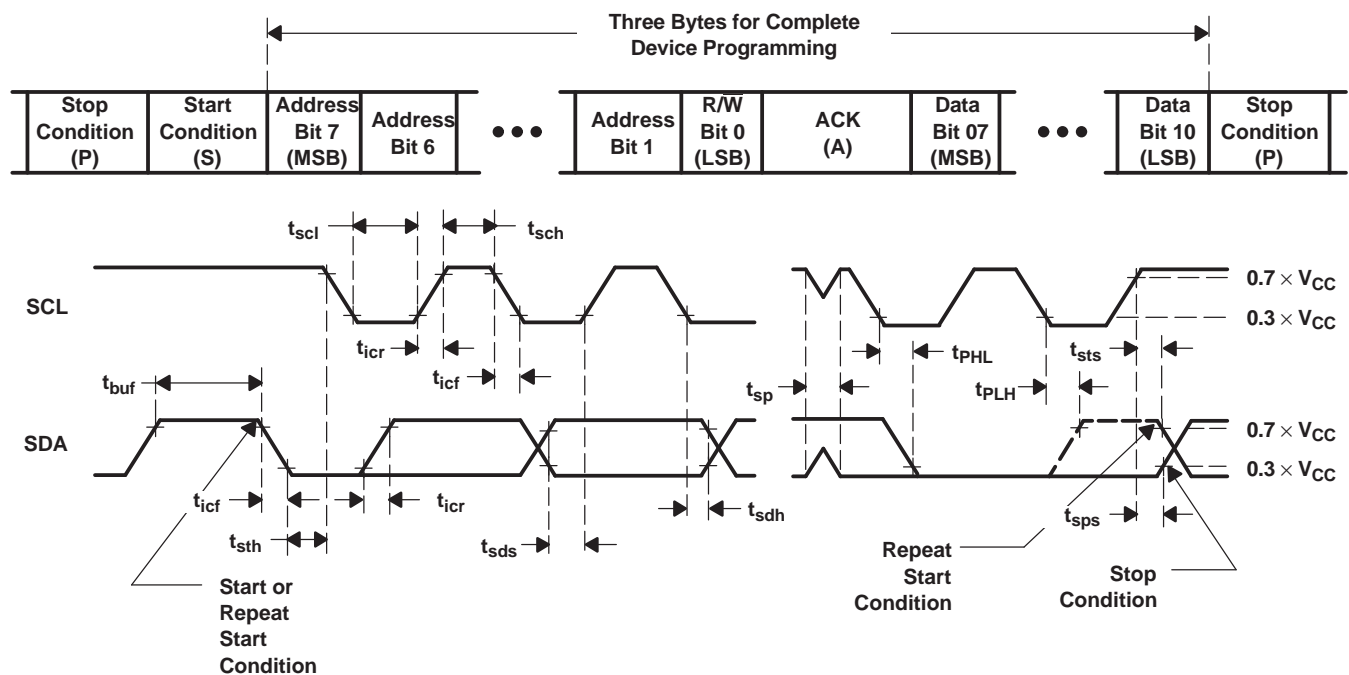

Figure 13. Output High Voltage vs Supply Voltage

7 Parameter Measurement Information



VOLTAGE WAVEFORMS

| BYTE | DESCRIPTION |
|------|--------------------------|
| 1 | I ² C address |
| 2, 3 | P-port data |

- A. C_L includes probe and jig capacitance.
- B. All inputs are supplied by generators having the following characteristics: $PRR \leq 10$ MHz, $Z_O = 50 \Omega$, $t_r/t_f \leq 30$ ns.
- C. All parameters and waveforms are not applicable to all devices.

Figure 14. I²C Interface Load Circuit And Voltage Waveforms

Parameter Measurement Information (continued)

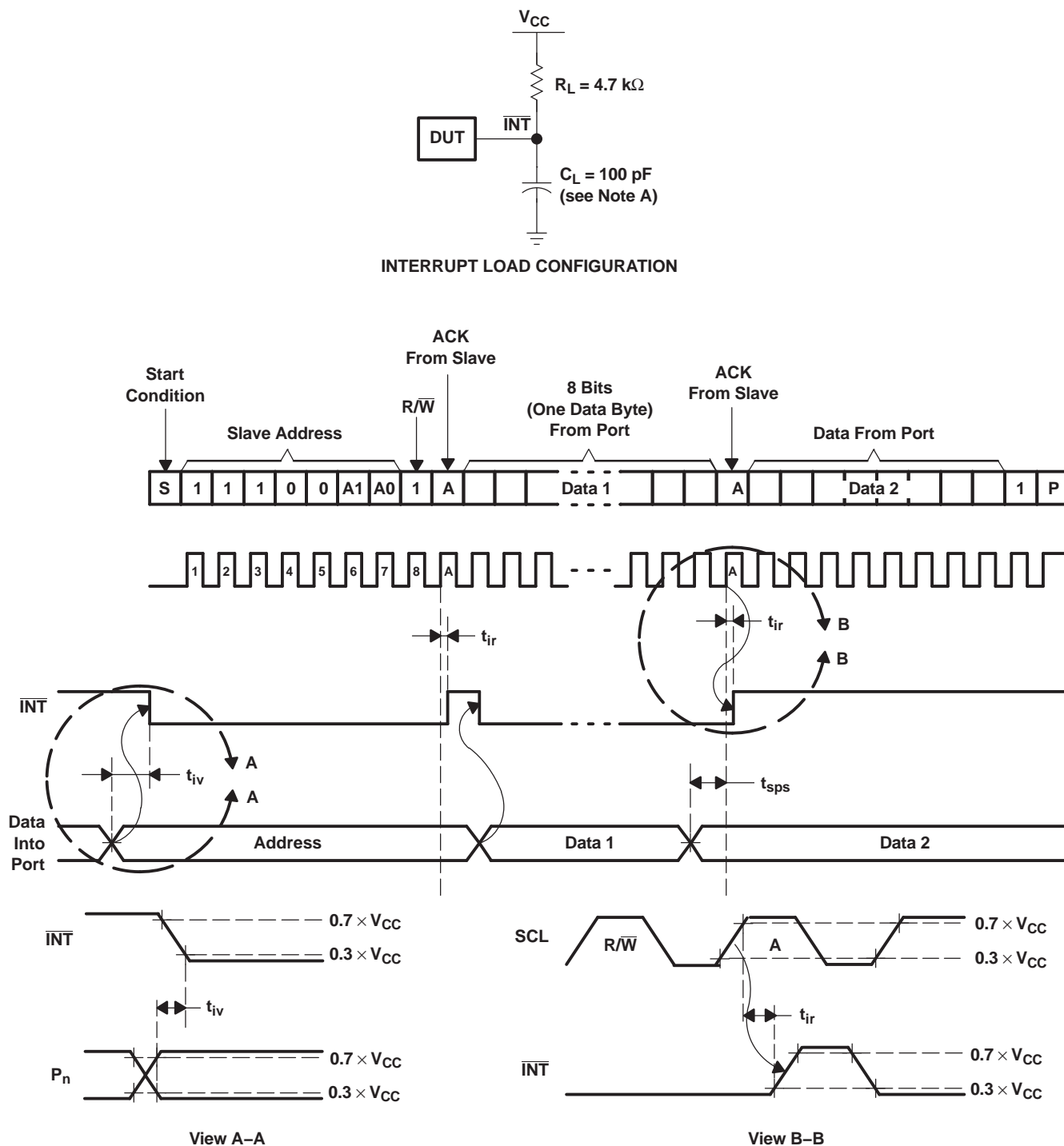

- A. C_L includes probe and jig capacitance.
- B. All inputs are supplied by generators having the following characteristics: PRR ≤ 10 MHz, Z_O = 50 Ω, t_r/t_f ≤ 30 ns.
- C. All parameters and waveforms are not applicable to all devices.

Figure 15. Interrupt Load Circuit And Voltage Waveforms

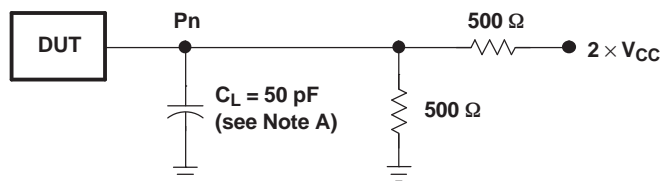
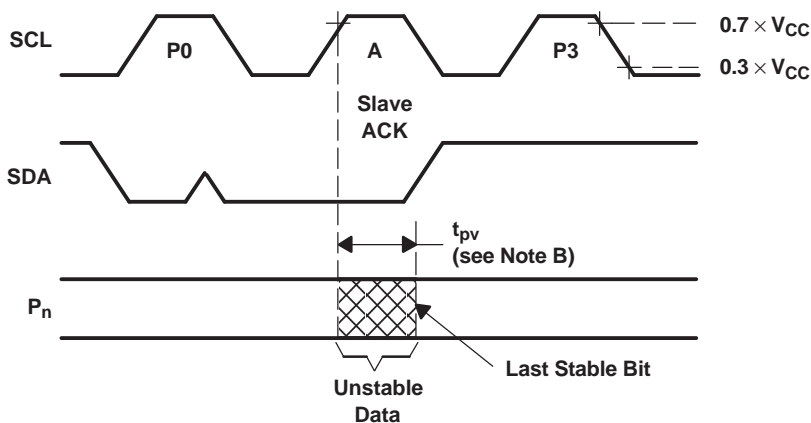
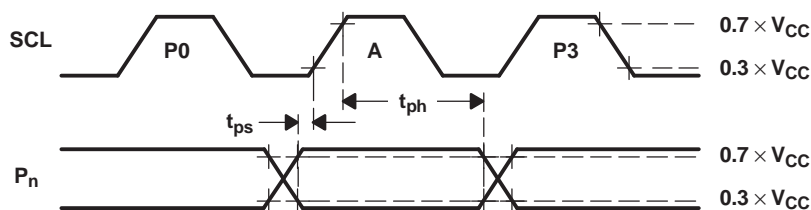
Parameter Measurement Information (continued)

P-PORT LOAD CONFIGURATION

WRITE MODE ($R/\bar{W} = 0$)

READ MODE ($R/\bar{W} = 1$)

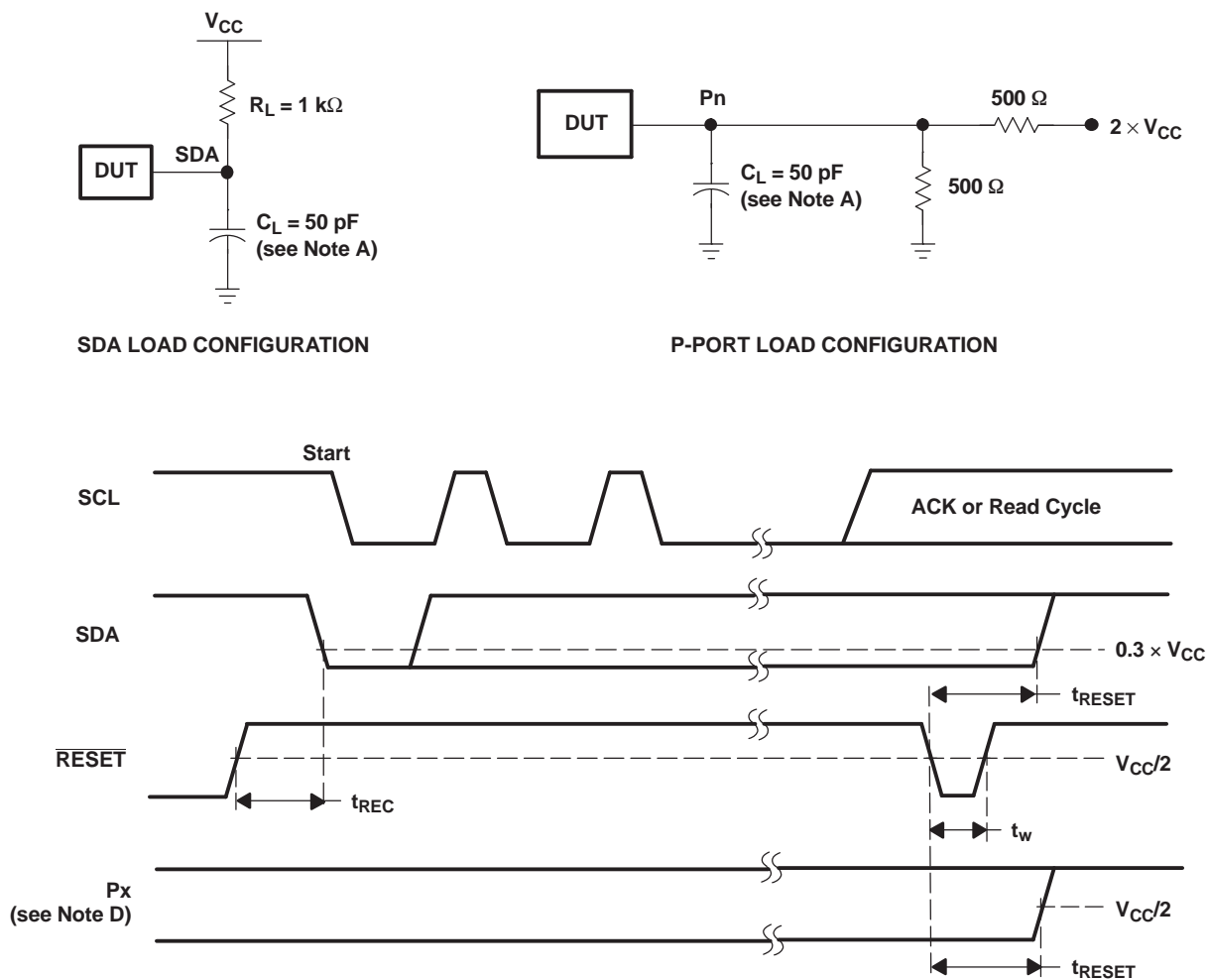
- A. C_L includes probe and jig capacitance.
- B. All inputs are supplied by generators having the following characteristics: $PRR \leq 10$ MHz, $Z_O = 50 \Omega$, $t_r/t_f \leq 30$ ns.
- C. The outputs are measured one at a time, with one transition per measurement.
- D. All parameters and waveforms are not applicable to all devices.

Figure 16. P-Port Load Circuit And Voltage Waveforms

Parameter Measurement Information (continued)



- A. C_L includes probe and jig capacitance.
- B. All inputs are supplied by generators having the following characteristics: $PRR \leq 10$ MHz, $Z_O = 50 \Omega$, $t_r/t_f \leq 30$ ns.
- C. The outputs are measured one at a time, with one transition per measurement.
- D. I/Os are configured as inputs.
- E. All parameters and waveforms are not applicable to all devices.

Figure 17. Reset Load Circuits And Voltage Waveforms

8 Detailed Description

8.1 Functional Block Diagram

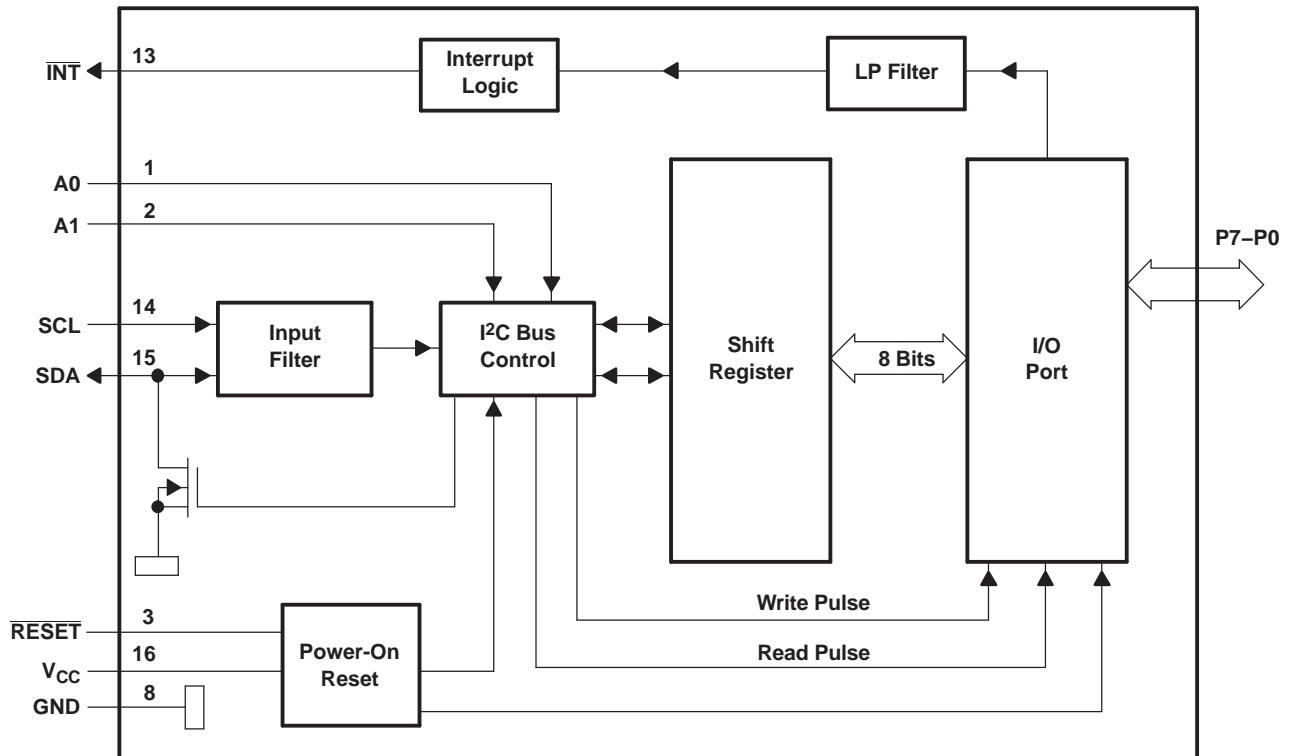

A. Pin numbers shown are for the DB, DBQ, DGV, DW, or PW package.

Figure 18. Functional Block Diagram

Functional Block Diagram (continued)

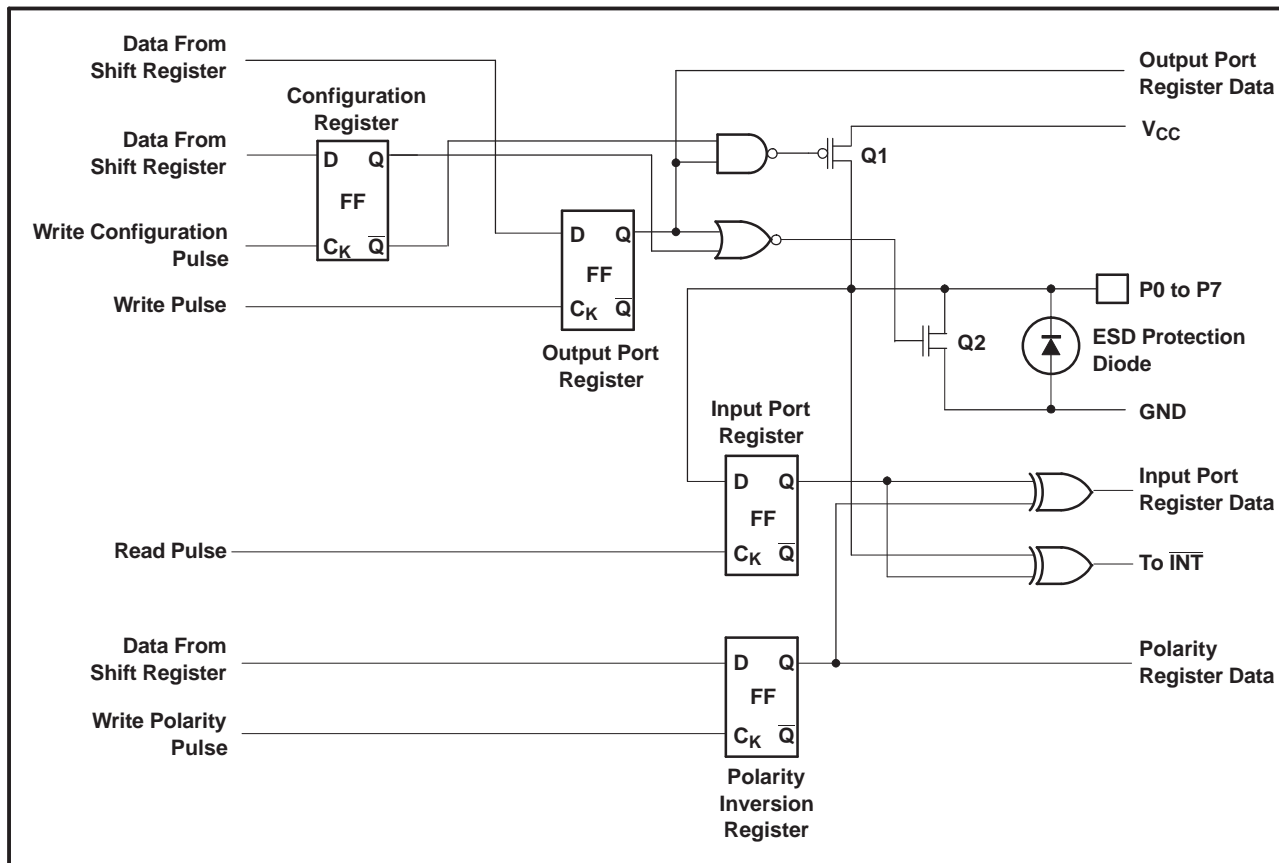

A. At power-on reset, all registers return to default values.

Figure 19. Simplified Schematic Of P0 To P7

8.2 Device Functional Modes

8.2.1 $\overline{\text{RESET}}$ Input

The $\overline{\text{RESET}}$ input can be asserted to reset the system while keeping the V_{CC} at its operating level. A reset can be accomplished by holding the $\overline{\text{RESET}}$ pin low for a minimum of t_W . The PCA9538 registers and I²C/SMBus state machine are changed to their default states once $\overline{\text{RESET}}$ is low (0). Once $\overline{\text{RESET}}$ is high (1), the I/O levels at the P port can be changed externally or through the master. This input requires a pullup resistor to V_{CC} if no active connection is used.

8.2.1.1 $\overline{\text{RESET}}$ Errata

If $\overline{\text{RESET}}$ voltage set higher than VCC, current will flow from $\overline{\text{RESET}}$ pin to VCC pin.

System Impact

VCC will be pulled above its regular voltage level

System Workaround

Design such that $\overline{\text{RESET}}$ voltage is same or lower than VCC

8.2.2 Power-On Reset

When power (from 0 V) is applied to V_{CC} , an internal power-on reset holds the PCA9538 in a reset condition until V_{CC} has reached V_{POR} . At that point, the reset condition is released and the PCA9538 registers and SMBus/I²C state machine will initialize to their default states. After that, V_{CC} must be lowered to below 0.2 V and then back up to the operating voltage for a power-reset cycle.

Please refer to the [Power-On Reset Errata](#) section.

8.2.3 I/O Port

When an I/O is configured as an input, FETs Q1 and Q2 (in [Figure 19](#)) are off, creating a high-impedance input. The input voltage may be raised above V_{CC} to a maximum of 5.5 V.

If the I/O is configured as an output, Q1 or Q2 is enabled depending on the state of the output port register. In this case, there are low impedance paths between the I/O pin and either V_{CC} or GND. The external voltage applied to this I/O pin should not exceed the recommended levels for proper operation.

Device Functional Modes (continued)

8.2.4 Interrupt Output ($\overline{\text{INT}}$)

An interrupt is generated by any rising or falling edge of the port inputs in the input mode. After time, t_{iv} , the signal $\overline{\text{INT}}$ is valid. Resetting the interrupt circuit is achieved when data on the port is changed to the original setting, data is read from the port that generated the interrupt. Resetting occurs in the read mode at the acknowledge (ACK) or not acknowledge (NACK) bit after the rising edge of the SCL signal.

Interrupts that occur during the ACK or NACK clock pulse can be lost (or be very short) due to the resetting of the interrupt during this pulse. Each change of the I/Os after resetting is detected and is transmitted as $\overline{\text{INT}}$. Writing to another device does not affect the interrupt circuit, and a pin configured as an output cannot cause an interrupt. Changing an I/O from an output to an input may cause a false interrupt to occur, if the state of the pin does not match the contents of the Input Port register. Because each 8-pin port is read independently, the interrupt caused by port 0 is not cleared by a read of port 1 or vice versa.

The $\overline{\text{INT}}$ output has an open-drain structure and requires pullup resistor to V_{CC} .

8.2.4.1 Interrupt Errata

The INT will be improperly de-asserted if the following two conditions occur:

1. The last I²C command byte (register pointer) written to the device was 00h.

NOTE

This generally means the last operation with the device was a Read of the input register. However, the command byte may have been written with 00h without ever going on to read the input register. After reading from the device, if no other command byte written, it will remain 00h.

2. Any other slave device on the I²C bus acknowledges an address byte with the R/W bit set high

System Impact

Can cause improper interrupt handling as the Master will see the interrupt as being cleared.

System Workaround

Minor software change: User must change command byte to something besides 00h after a Read operation to the PCA9538 device or before reading from another slave device.

NOTE

Software change will be compatible with other versions (competition and TI redesigns) of this device.

8.3 Programming

8.3.1 I²C Interface

The bidirectional I²C bus consists of the serial clock (SCL) and serial data (SDA) lines. Both lines must be connected to a positive supply through a pull-up resistor when connected to the output stages of a device. Data transfer may be initiated only when the bus is not busy.

I²C communication with this device is initiated by a master sending a Start condition, a high-to-low transition on the SDA input/output while the SCL input is high (see [Figure 20](#)). After the Start condition, the device address byte is sent, most significant bit (MSB) first, including the data direction bit (R/W).

After receiving the valid address byte, this device responds with an acknowledge (ACK), a low on the SDA input/output during the high of the ACK-related clock pulse. The address inputs (A0–A1) of the slave device must not be changed between the Start and the Stop conditions.

On the I²C bus, only one data bit is transferred during each clock pulse. The data on the SDA line must remain stable during the high pulse of the clock period, as changes in the data line at this time are interpreted as control commands (Start or Stop) (see [Figure 21](#)).

Programming (continued)

A Stop condition, a low-to-high transition on the SDA input/output while the SCL input is high, is sent by the master (see [Figure 20](#)).

Any number of data bytes can be transferred from the transmitter to receiver between the Start and the Stop conditions. Each byte of eight bits is followed by one ACK bit. The transmitter must release the SDA line before the receiver can send an ACK bit. The device that acknowledges must pull down the SDA line during the ACK clock pulse so that the SDA line is stable low during the high pulse of the ACK-related clock period (see [Figure 22](#)). When a slave receiver is addressed, it must generate an ACK after each byte is received. Similarly, the master must generate an ACK after each byte that it receives from the slave transmitter. Setup and hold times must be met to ensure proper operation.

A master receiver will signal an end of data to the slave transmitter by not generating an acknowledge (NACK) after the last byte has been clocked out of the slave. This is done by the master receiver by holding the SDA line high. In this event, the transmitter must release the data line to enable the master to generate a Stop condition.

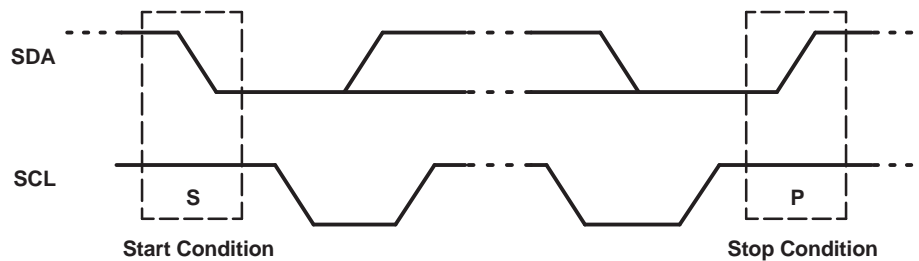

Figure 20. Definition Of Start And Stop Conditions

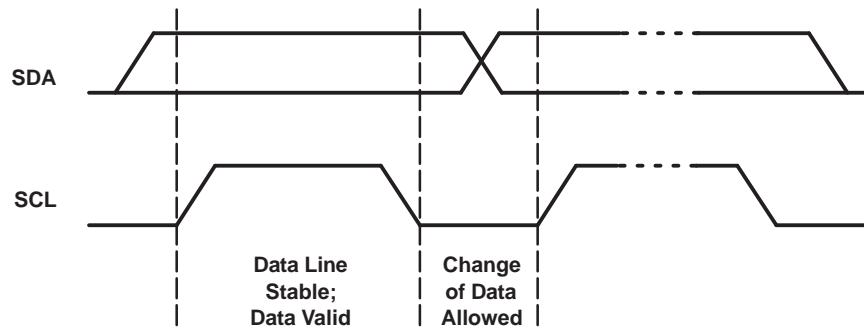

Figure 21. Bit Transfer

Programming (continued)

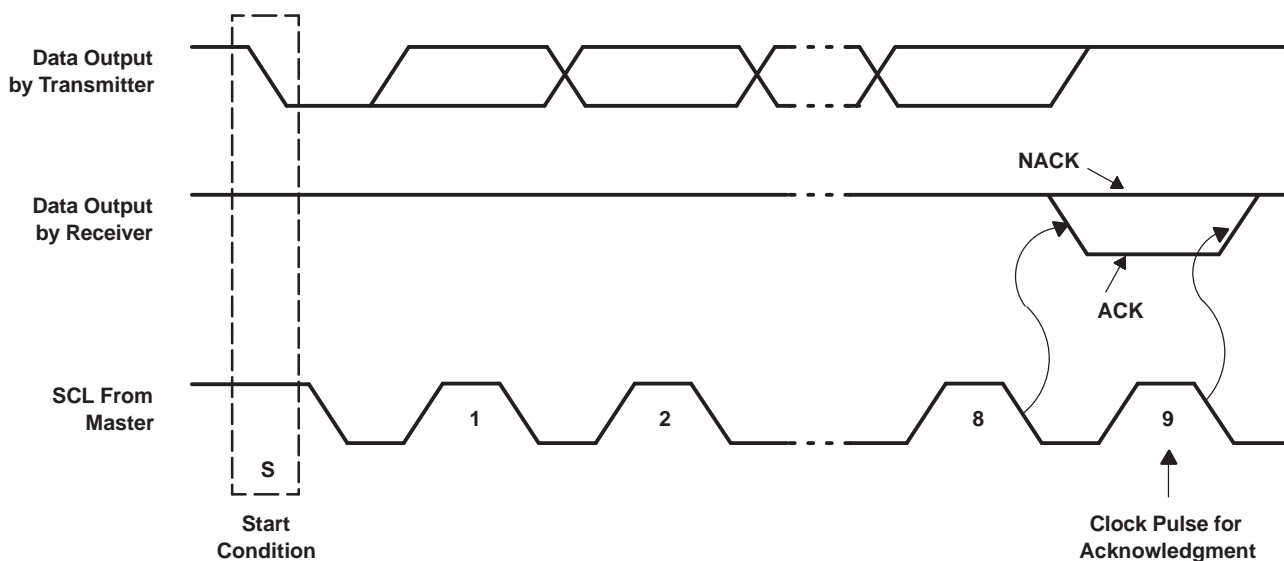

Figure 22. Acknowledgment On I²C Bus

8.3.2 Register Map

Table 1. Interface Definition Table

| BYTE | BIT | | | | | | | |
|--------------------------------|---------|----|----|----|----|----|----|---------|
| | 7 (MSB) | 6 | 5 | 4 | 3 | 2 | 1 | 0 (LSB) |
| I ² C slave address | H | H | H | L | L | A1 | A0 | R/W |
| Px I/O data bus | P7 | P6 | P5 | P4 | P3 | P2 | P1 | P0 |

8.3.2.1 Device Address

Figure 23 shows the address byte of the PCA9538.

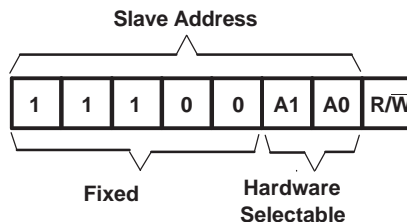

Figure 23. PCA9538 Address

Table 2. Address Reference Table

| INPUTS | | I ² C BUS SLAVE ADDRESS |
|--------|----|------------------------------------|
| A1 | A0 | |
| L | L | 112 (decimal), 70 (hexadecimal) |
| L | H | 113 (decimal), 71 (hexadecimal) |
| H | L | 114 (decimal), 72 (hexadecimal) |
| H | H | 115 (decimal), 73 (hexadecimal) |

The last bit of the slave address defines the operation (read or write) to be performed. When it is high (1), a read is selected while a low (0) selects a write operation.

8.3.2.2 Control Register And Command Byte

Following the successful Acknowledgment of the address byte, the bus master sends a command byte that is stored in the control register in the PCA9538 (see [Figure 24](#)). Two bits of this command byte state the operation (read or write) and the internal register (input, output, polarity inversion or configuration) that will be affected. This register can be written or read through the I²C bus. The command byte is sent only during a write transmission.

Once a command byte has been sent, the register that was addressed continues to be accessed by reads until a new command byte has been sent.

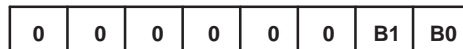
Figure 24. Control Register Bits
Table 3. Command Byte Table

| CONTROL REGISTER BITS | | COMMAND BYTE (HEX) | REGISTER | PROTOCOL | POWER-UP DEFAULT |
|-----------------------|----|--------------------|--------------------|-----------------|------------------|
| B1 | B0 | | | | |
| 0 | 0 | 0x00 | Input Port | Read byte | XXXX XXXX |
| 0 | 1 | 0x01 | Output Port | Read/write byte | 1111 1111 |
| 1 | 0 | 0x02 | Polarity Inversion | Read/write byte | 0000 0000 |
| 1 | 1 | 0x03 | Configuration | Read/write byte | 1111 1111 |

8.3.2.3 Register Descriptions

The Input Port register (register 0) reflects the incoming logic levels of the pins, regardless of whether the pin is defined as an input or an output by the Configuration register. It only acts on read operation. Writes to these registers have no effect. The default value, X, is determined by the externally applied logic level.

Before a read operation, a write transmission is sent with the command byte to indicate to the I²C device that the Input Port register is accessed next.

Table 4. Register 0 (Input Port Register) Table

| BIT | I7 | I6 | I5 | I4 | I3 | I2 | I1 | I0 |
|---------|----|----|----|----|----|----|----|----|
| DEFAULT | X | X | X | X | X | X | X | X |

The Output Port register (register 1) shows the outgoing logic levels of the pins defined as outputs by the Configuration register. Bit values in this register have no effect on pins defined as inputs. In turn, reads from this register reflect the value that is in the flip-flop controlling the output selection, not the actual pin value.

Table 5. Register 1 (Output Port Register) Table

| BIT | O7 | O6 | O5 | O4 | O3 | O2 | O1 | O0 |
|---------|----|----|----|----|----|----|----|----|
| DEFAULT | 1 | 1 | 1 | 1 | 1 | 1 | 1 | 1 |

The Polarity Inversion register (register 2) allows polarity inversion of pins defined as inputs by the Configuration register. If a bit in this register is set (written with 1), the corresponding port pin polarity is inverted. If a bit in this register is cleared (written with a 0), the corresponding port pin original polarity is retained.

Table 6. Register 2 (Polarity Inversion Register) Table

| BIT | N7 | N6 | N5 | N4 | N3 | N2 | N1 | N0 |
|---------|----|----|----|----|----|----|----|----|
| DEFAULT | 0 | 0 | 0 | 0 | 0 | 0 | 0 | 0 |

The Configuration register (register 3) configures the directions of the I/O pins. If a bit in this register is set to 1, the corresponding port pin is enabled as an input with a high-impedance output driver. If a bit in this register is cleared to 0, the corresponding port pin is enabled as an output.

Table 7. Register 3 (Configuration Register) Table

| BIT | C7 | C6 | C5 | C4 | C3 | C2 | C1 | C0 |
|---------|----|----|----|----|----|----|----|----|
| DEFAULT | 1 | 1 | 1 | 1 | 1 | 1 | 1 | 1 |

8.3.2.4 Bus Transactions

Data is exchanged between the master and PCA9538 through write and read commands.

8.3.2.4.1 Writes

Data is transmitted to the PCA9538 by sending the device address and setting the least-significant bit (LSB) to a logic 0 (see Figure 23 for device address). The command byte is sent after the address and determines which register receives the data that follows the command byte (see Figure 25 and Figure 26). There is no limitation on the number of data bytes sent in one write transmission.

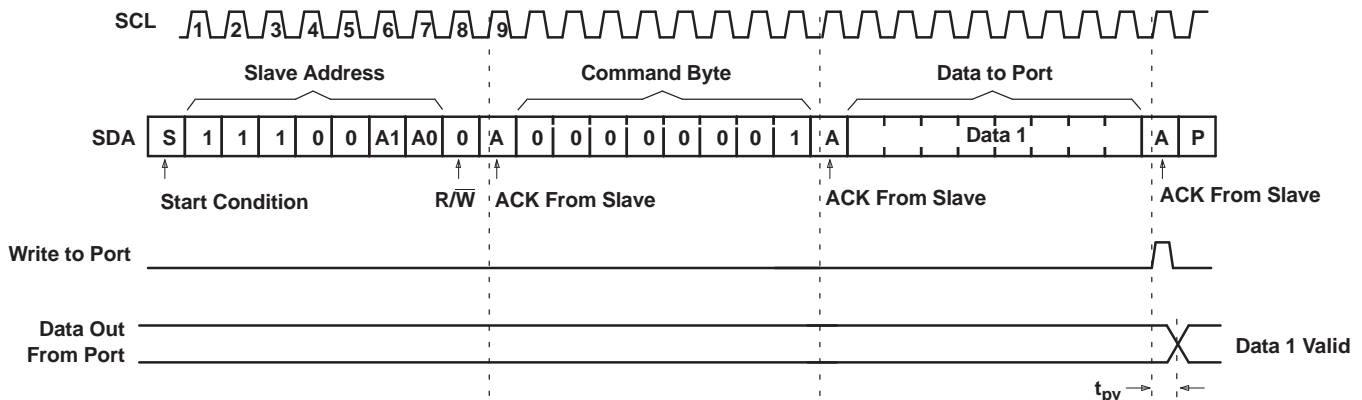

Figure 25. Write To Output Port Register

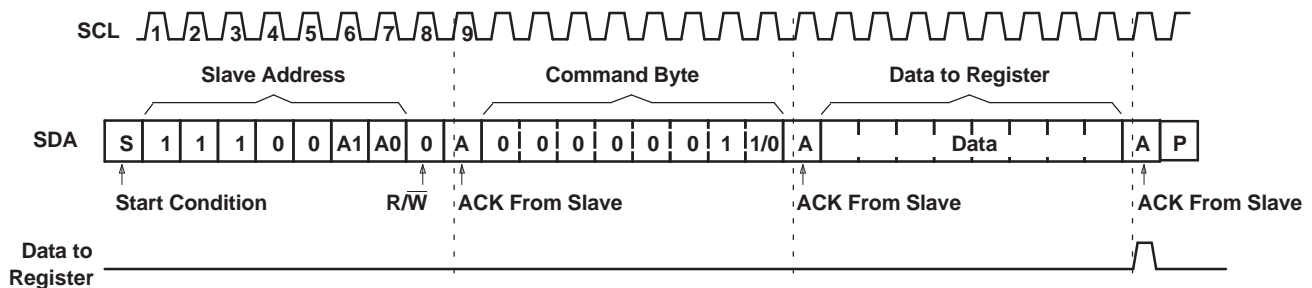

Figure 26. Write To Configuration Or Polarity Inversion Registers

8.3.2.4.2 Reads

The bus master first must send the PCA9538 address with the LSB set to a logic 0 (see Figure 23 for device address). The command byte is sent after the address and determines which register is accessed. After a restart, the device address is sent again but, this time, the LSB is set to a logic 1. Data from the register defined by the command byte then is sent by the PCA9538 (see Figure 27 and Figure 28). After a restart, the value of the register defined by the command byte matches the register being accessed when the restart occurred. Data is clocked into the register on the rising edge of the ACK clock pulse. There is no limitation on the number of data bytes received in one read transmission, but when the final byte is received, the bus master must not acknowledge the data.

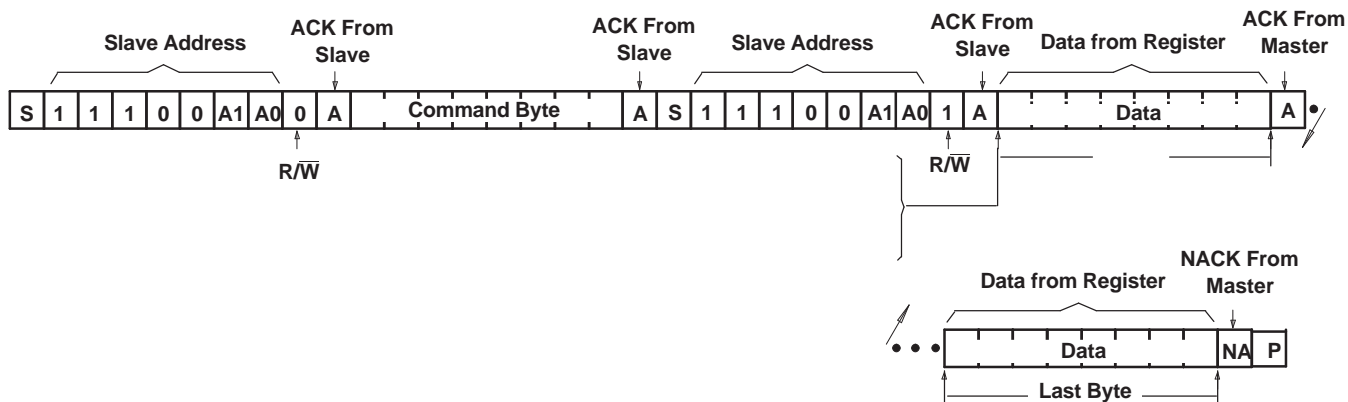
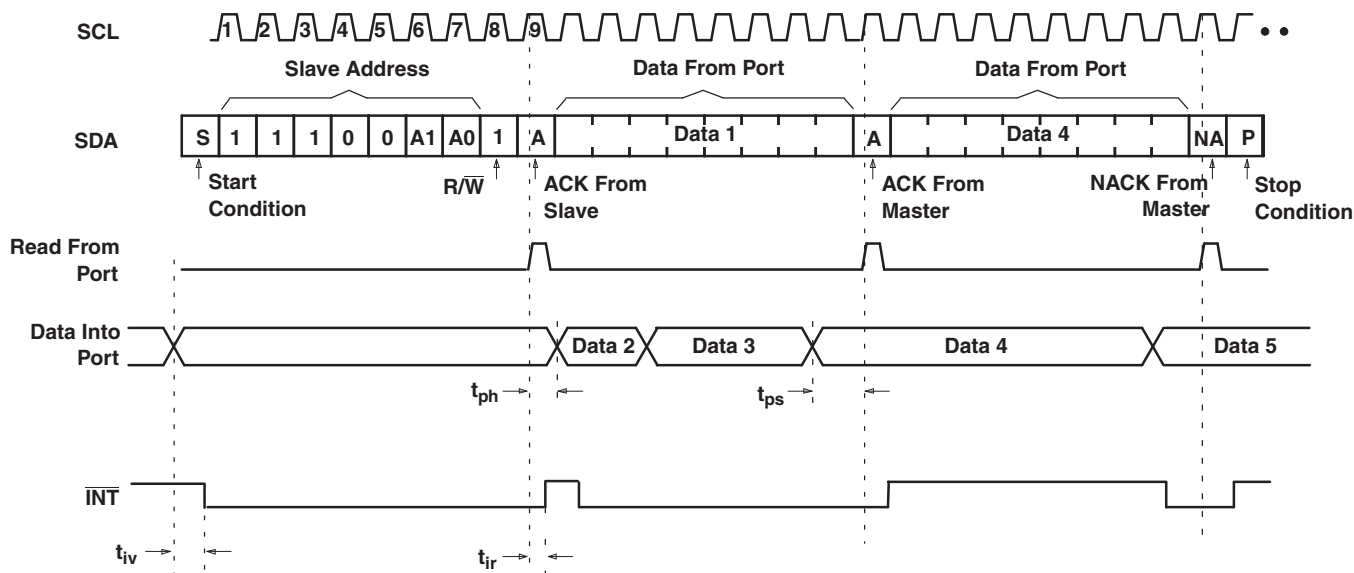

Figure 27. Read From Register



- A. This figure assumes the command byte has previously been programmed with 00h.
- B. Transfer of data can be stopped at any moment by a Stop condition.
- C. This figure eliminates the command byte transfer, a restart, and slave address call between the initial slave address call and actual data transfer from the P port. See Figure 27 for these details.

Figure 28. Read From Input Port Register

9 Application And Implementation

9.1 Typical Application

Figure 29 shows an application in which the PCA9538 can be used.

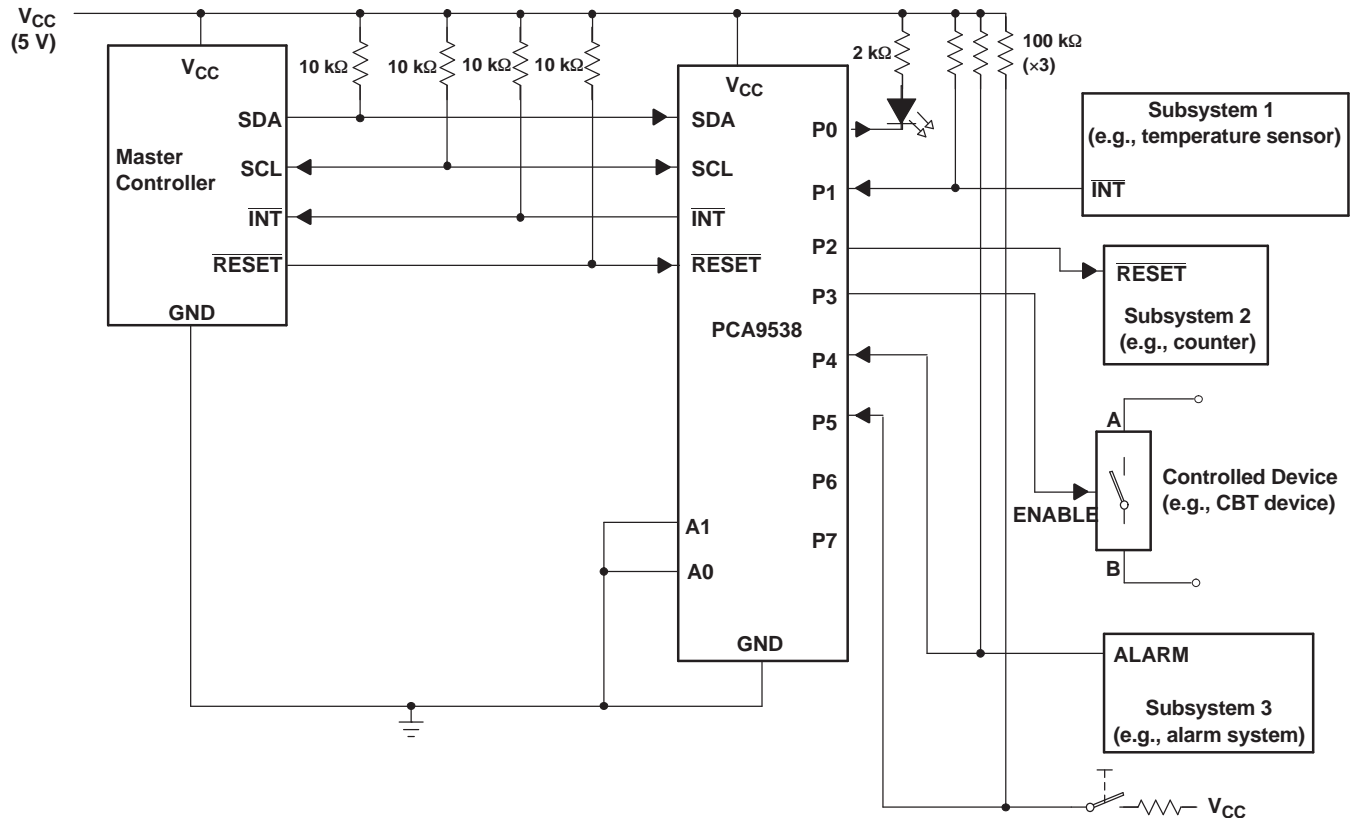

- Device address is configured as 1110000 for this example.
- P0, P2, and P3 are configured as outputs.
- P1, P4, and P5 are configured as inputs.
- P6 and P7 are not used and must be configured as outputs.

Figure 29. Typical Application

Typical Application (continued)

9.1.1 Detailed Design Procedure

9.1.1.1 Minimizing I_{CC} When I/Os Control Leds

When the I/Os are used to control LEDs, normally they are connected to V_{CC} through a resistor as shown in Figure 29. The LED acts as a diode, so when the LED is off, the I/O V_{IN} is about 1.2 V less than V_{CC} . I_{CC} in Electrical Characteristics shows how I_{CC} increases as V_{IN} becomes lower than V_{CC} .

For battery-powered applications, it is essential that the voltage of I/O pins is greater than or equal to V_{CC} when the LED is off to minimize current consumption. Figure 30 shows a high-value resistor in parallel with the LED. Figure 31 shows V_{CC} less than the LED supply voltage by at least 1.2 V. Both of these methods maintain the I/O V_{IN} at or above V_{CC} and prevents additional supply current consumption when the LED is off.

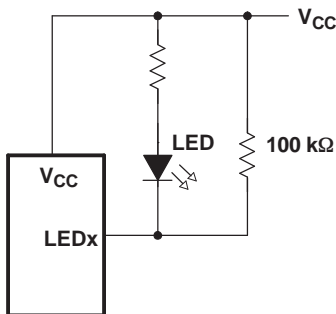

Figure 30. High-Value Resistor In Parallel With Led

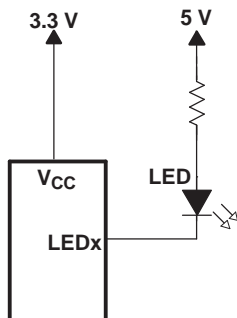
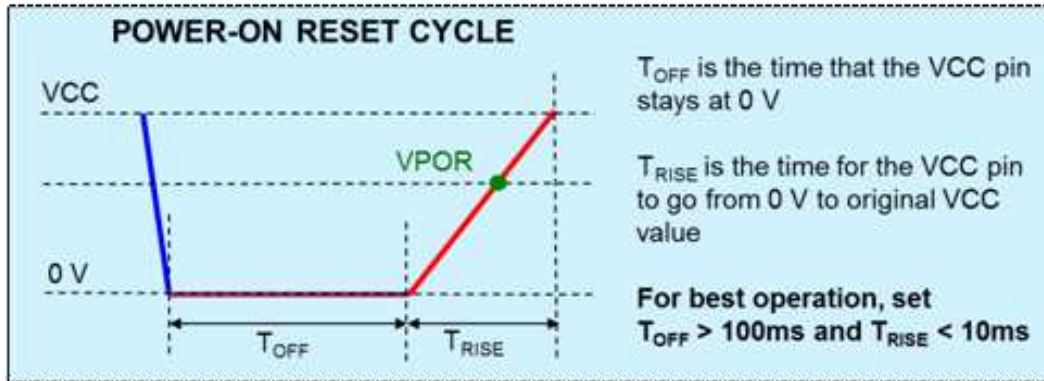

Figure 31. Device Supplied By A Lower Voltage

10 Power Supply Recommendations

10.1 Power-On Reset Errata

A power-on reset condition can be missed if the VCC ramps are outside specification listed below.



System Impact

If ramp conditions are outside timing allowances above, POR condition can be missed, causing the device to lock up.

11 Device and Documentation Support

11.1 Trademarks

All trademarks are the property of their respective owners.

11.2 Electrostatic Discharge Caution



These devices have limited built-in ESD protection. The leads should be shorted together or the device placed in conductive foam during storage or handling to prevent electrostatic damage to the MOS gates.

11.3 Glossary

[SLYZ022](#) — *TI Glossary*.

This glossary lists and explains terms, acronyms, and definitions.

12 Mechanical, Packaging, and Orderable Information

The following pages include mechanical, packaging, and orderable information. This information is the most current data available for the designated devices. This data is subject to change without notice and revision of this document. For browser-based versions of this data sheet, refer to the left-hand navigation.

PACKAGING INFORMATION

| Orderable Device | Status (1) | Package Type | Package Drawing | Pins | Package Qty | Eco Plan (2) | Lead/Ball Finish (6) | MSL Peak Temp (3) | Op Temp (°C) | Device Marking (4/5) | Samples |
|------------------|---------------|--------------|-----------------|------|-------------|-------------------------|-------------------------|----------------------|--------------|-------------------------|-------------------------|
| PCA9538DB | ACTIVE | SSOP | DB | 16 | 80 | Green (RoHS & no Sb/Br) | CU NIPDAU | Level-1-260C-UNLIM | -40 to 85 | PD538 | Samples |
| PCA9538DBR | ACTIVE | SSOP | DB | 16 | 2000 | Green (RoHS & no Sb/Br) | CU NIPDAU | Level-1-260C-UNLIM | -40 to 85 | PD538 | Samples |
| PCA9538DGVR | ACTIVE | TVSOP | DGV | 16 | 2000 | Green (RoHS & no Sb/Br) | CU NIPDAU | Level-1-260C-UNLIM | -40 to 85 | PD538 | Samples |
| PCA9538DW | ACTIVE | SOIC | DW | 16 | 40 | Green (RoHS & no Sb/Br) | CU NIPDAU | Level-1-260C-UNLIM | -40 to 85 | PCA9538 | Samples |
| PCA9538DWR | ACTIVE | SOIC | DW | 16 | 2000 | Green (RoHS & no Sb/Br) | CU NIPDAU | Level-1-260C-UNLIM | -40 to 85 | PCA9538 | Samples |
| PCA9538PW | ACTIVE | TSSOP | PW | 16 | 90 | Green (RoHS & no Sb/Br) | CU NIPDAU | Level-1-260C-UNLIM | -40 to 85 | PD538 | Samples |
| PCA9538PWG4 | ACTIVE | TSSOP | PW | 16 | 90 | Green (RoHS & no Sb/Br) | CU NIPDAU | Level-1-260C-UNLIM | -40 to 85 | PD538 | Samples |
| PCA9538PWR | ACTIVE | TSSOP | PW | 16 | 2000 | Green (RoHS & no Sb/Br) | CU NIPDAU | Level-1-260C-UNLIM | -40 to 85 | PD538 | Samples |

(1) The marketing status values are defined as follows:

ACTIVE: Product device recommended for new designs.

LIFEBUY: TI has announced that the device will be discontinued, and a lifetime-buy period is in effect.

NRND: Not recommended for new designs. Device is in production to support existing customers, but TI does not recommend using this part in a new design.

PREVIEW: Device has been announced but is not in production. Samples may or may not be available.

OBsolete: TI has discontinued the production of the device.

(2) **RoHS:** TI defines "RoHS" to mean semiconductor products that are compliant with the current EU RoHS requirements for all 10 RoHS substances, including the requirement that RoHS substance do not exceed 0.1% by weight in homogeneous materials. Where designed to be soldered at high temperatures, "RoHS" products are suitable for use in specified lead-free processes. TI may reference these types of products as "Pb-Free".

RoHS Exempt: TI defines "RoHS Exempt" to mean products that contain lead but are compliant with EU RoHS pursuant to a specific EU RoHS exemption.

Green: TI defines "Green" to mean the content of Chlorine (Cl) and Bromine (Br) based flame retardants meet JS709B low halogen requirements of <=100ppm threshold. Antimony trioxide based flame retardants must also meet the <=1000ppm threshold requirement.

(3) MSL, Peak Temp. - The Moisture Sensitivity Level rating according to the JEDEC industry standard classifications, and peak solder temperature.

(4) There may be additional marking, which relates to the logo, the lot trace code information, or the environmental category on the device.

⁽⁵⁾ Multiple Device Markings will be inside parentheses. Only one Device Marking contained in parentheses and separated by a "-" will appear on a device. If a line is indented then it is a continuation of the previous line and the two combined represent the entire Device Marking for that device.

⁽⁶⁾ Lead/Ball Finish - Orderable Devices may have multiple material finish options. Finish options are separated by a vertical ruled line. Lead/Ball Finish values may wrap to two lines if the finish value exceeds the maximum column width.

Important Information and Disclaimer:The information provided on this page represents TI's knowledge and belief as of the date that it is provided. TI bases its knowledge and belief on information provided by third parties, and makes no representation or warranty as to the accuracy of such information. Efforts are underway to better integrate information from third parties. TI has taken and continues to take reasonable steps to provide representative and accurate information but may not have conducted destructive testing or chemical analysis on incoming materials and chemicals. TI and TI suppliers consider certain information to be proprietary, and thus CAS numbers and other limited information may not be available for release.

In no event shall TI's liability arising out of such information exceed the total purchase price of the TI part(s) at issue in this document sold by TI to Customer on an annual basis.

TAPE AND REEL INFORMATION



QUADRANT ASSIGNMENTS FOR PIN 1 ORIENTATION IN TAPE



*All dimensions are nominal

| Device | Package Type | Package Drawing | Pins | SPQ | Reel Diameter (mm) | Reel Width W1 (mm) | A0 (mm) | B0 (mm) | K0 (mm) | P1 (mm) | W (mm) | Pin1 Quadrant |
|-------------|--------------|-----------------|------|------|--------------------|--------------------|---------|---------|---------|---------|--------|---------------|
| PCA9538DGVR | TVSOP | DGV | 16 | 2000 | 330.0 | 12.4 | 6.8 | 4.0 | 1.6 | 8.0 | 12.0 | Q1 |
| PCA9538DWR | SOIC | DW | 16 | 2000 | 330.0 | 16.4 | 10.75 | 10.7 | 2.7 | 12.0 | 16.0 | Q1 |
| PCA9538PWR | TSSOP | PW | 16 | 2000 | 330.0 | 12.4 | 6.9 | 5.6 | 1.6 | 8.0 | 12.0 | Q1 |

TAPE AND REEL BOX DIMENSIONS

*All dimensions are nominal

| Device | Package Type | Package Drawing | Pins | SPQ | Length (mm) | Width (mm) | Height (mm) |
|-------------|--------------|-----------------|------|------|-------------|------------|-------------|
| PCA9538DGVR | TVSOP | DGV | 16 | 2000 | 367.0 | 367.0 | 35.0 |
| PCA9538DWR | SOIC | DW | 16 | 2000 | 350.0 | 350.0 | 43.0 |
| PCA9538PWR | TSSOP | PW | 16 | 2000 | 367.0 | 367.0 | 35.0 |



4220204/A 02/2017

NOTES:

1. All linear dimensions are in millimeters. Any dimensions in parenthesis are for reference only. Dimensioning and tolerancing per ASME Y14.5M.
2. This drawing is subject to change without notice.
3. This dimension does not include mold flash, protrusions, or gate burrs. Mold flash, protrusions, or gate burrs shall not exceed 0.15 mm per side.
4. This dimension does not include interlead flash. Interlead flash shall not exceed 0.25 mm per side.
5. Reference JEDEC registration MO-153.

EXAMPLE BOARD LAYOUT

PW0016A

TSSOP - 1.2 mm max height

SMALL OUTLINE PACKAGE



LAND PATTERN EXAMPLE
EXPOSED METAL SHOWN
SCALE: 10X



SOLDER MASK DETAILS

4220204/A 02/2017

NOTES: (continued)

- 6. Publication IPC-7351 may have alternate designs.
- 7. Solder mask tolerances between and around signal pads can vary based on board fabrication site.

EXAMPLE STENCIL DESIGN

PW0016A

TSSOP - 1.2 mm max height

SMALL OUTLINE PACKAGE



SOLDER PASTE EXAMPLE
BASED ON 0.125 mm THICK STENCIL
SCALE: 10X

4220204/A 02/2017

NOTES: (continued)

8. Laser cutting apertures with trapezoidal walls and rounded corners may offer better paste release. IPC-7525 may have alternate design recommendations.
9. Board assembly site may have different recommendations for stencil design.

GENERIC PACKAGE VIEW

DW 16

SOIC - 2.65 mm max height

7.5 x 10.3, 1.27 mm pitch

SMALL OUTLINE INTEGRATED CIRCUIT

This image is a representation of the package family, actual package may vary.
Refer to the product data sheet for package details.

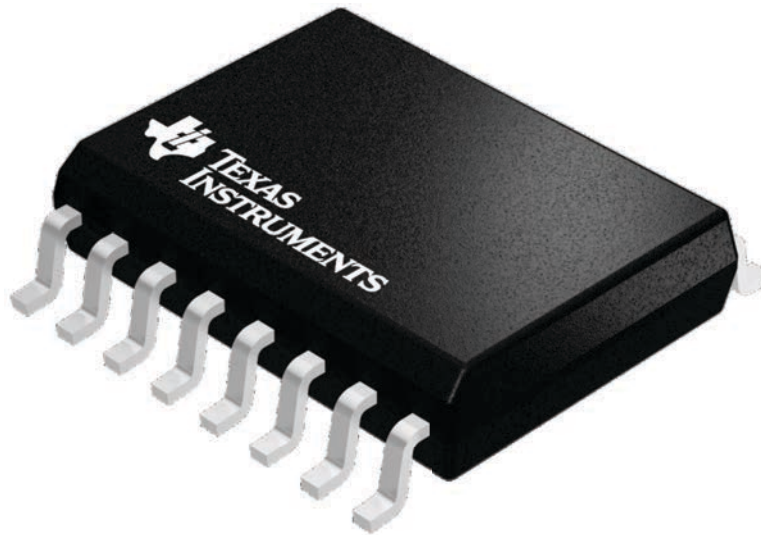

4224780/A

EXAMPLE BOARD LAYOUT

DW0016A

SOIC - 2.65 mm max height

SOIC

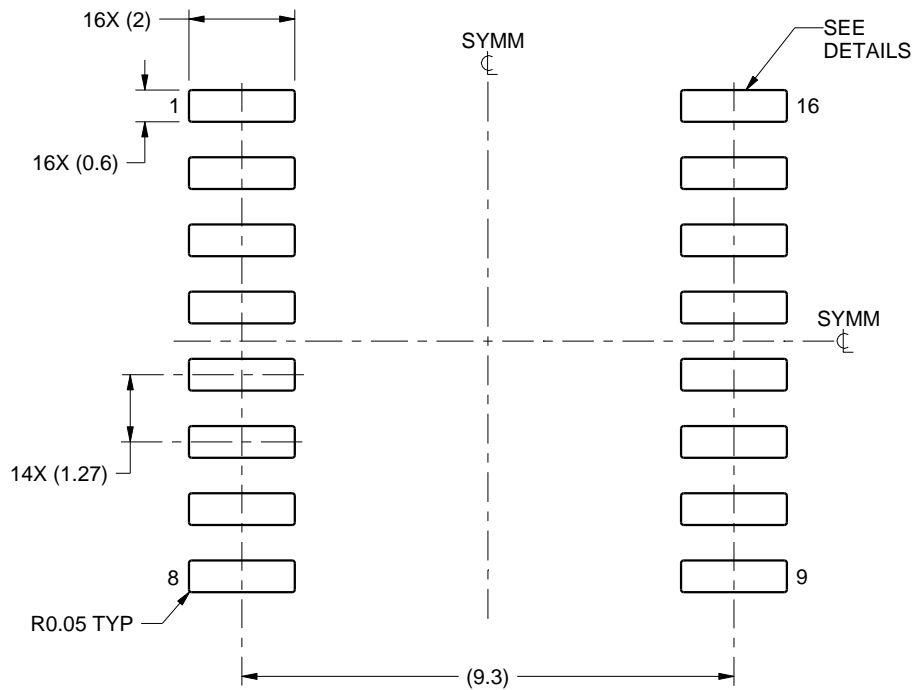

LAND PATTERN EXAMPLE
SCALE:7X

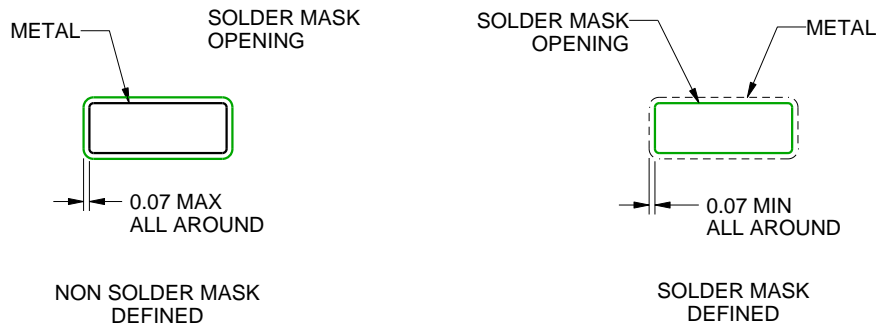

SOLDER MASK DETAILS

4220721/A 07/2016

NOTES: (continued)

- 6. Publication IPC-7351 may have alternate designs.
- 7. Solder mask tolerances between and around signal pads can vary based on board fabrication site.

EXAMPLE STENCIL DESIGN

DW0016A

SOIC - 2.65 mm max height

SOIC

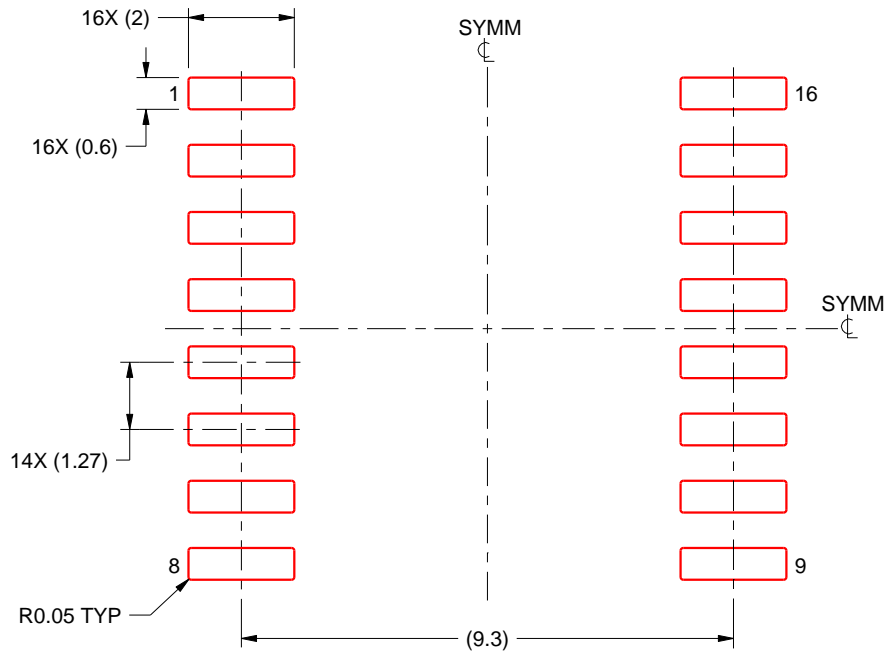

SOLDER PASTE EXAMPLE
BASED ON 0.125 mm THICK STENCIL
SCALE:7X

4220721/A 07/2016

NOTES: (continued)

8. Laser cutting apertures with trapezoidal walls and rounded corners may offer better paste release. IPC-7525 may have alternate design recommendations.
9. Board assembly site may have different recommendations for stencil design.

IMPORTANT NOTICE AND DISCLAIMER

TI PROVIDES TECHNICAL AND RELIABILITY DATA (INCLUDING DATASHEETS), DESIGN RESOURCES (INCLUDING REFERENCE DESIGNS), APPLICATION OR OTHER DESIGN ADVICE, WEB TOOLS, SAFETY INFORMATION, AND OTHER RESOURCES "AS IS" AND WITH ALL FAULTS, AND DISCLAIMS ALL WARRANTIES, EXPRESS AND IMPLIED, INCLUDING WITHOUT LIMITATION ANY IMPLIED WARRANTIES OF MERCHANTABILITY, FITNESS FOR A PARTICULAR PURPOSE OR NON-INFRINGEMENT OF THIRD PARTY INTELLECTUAL PROPERTY RIGHTS.

These resources are intended for skilled developers designing with TI products. You are solely responsible for (1) selecting the appropriate TI products for your application, (2) designing, validating and testing your application, and (3) ensuring your application meets applicable standards, and any other safety, security, or other requirements. These resources are subject to change without notice. TI grants you permission to use these resources only for development of an application that uses the TI products described in the resource. Other reproduction and display of these resources is prohibited. No license is granted to any other TI intellectual property right or to any third party intellectual property right. TI disclaims responsibility for, and you will fully indemnify TI and its representatives against, any claims, damages, costs, losses, and liabilities arising out of your use of these resources.

TI's products are provided subject to TI's Terms of Sale (www.ti.com/legal/termsofsale.html) or other applicable terms available either on ti.com or provided in conjunction with such TI products. TI's provision of these resources does not expand or otherwise alter TI's applicable warranties or warranty disclaimers for TI products.

Mailing Address: Texas Instruments, Post Office Box 655303, Dallas, Texas 75265
Copyright © 2019, Texas Instruments Incorporated

Looking for pricing, stock, or lifecycle information?

Click below to explore more details on WIN SOURCE:

 [View PCA9538DBR on WIN SOURCE](#)

 [Texas Instruments](#) Information

Optimize Your Supply Chain with WIN SOURCE Solutions

-  Global Sourcing Solution
-  Obsolete Management
-  Cost Control Management
-  Shortage Management
-  Alternative Solution
-  Excess Inventory Management