



**THE DATASHEET OF
PCA9504ADGG,112**



DATA SHEET



PCA9504A Glue chip 4

Product data
Supersedes data of 2003 Nov 10

2004 May 11

Glue chip 4

PCA9504A

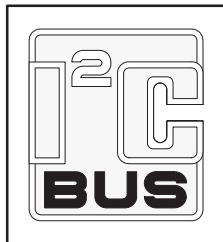

FEATURES

- Dual, Strapping, Selectable Feature Sets
- Audio-disable Circuit
- Mute Audio Circuit
- 5 V reference generation
- 5 V standby reference generation
- HD single color LED driver
- IDE reset signal generation/PCIRST# buffers
- PWROK (PWRGD_3V) signal generation
- Power Sequencing / BACKFEED_CUT
- Power Supply turn on circuitry
- RMSRST# generation
- Voltage translation for DDC to VGA monitor
- HSYNCH / VSYNCH voltage translation to VGA monitor
- 3-state buffers for test
- Extra GP Logic gates
- Power LED Drivers
- Flash FLUSH# / INIT# circuit
- 5 V I²C to 3.3 V SMBus conversion to 400 kHz
- Requires both 3.3 V and 5.0 V operating voltages
- 0 to +70 °C operating temperature range
- ESD protection exceeds 1000 V HBM per JESD22-A114 and 750 V CDM per JESD22-C101
- Latch-up testing is done to JEDEC Standard JESD78 which exceeds 100 mA
- Package offered: TSSOP56

DESCRIPTION

The PCA9504A Glue Chip 4 is a highly integrated and cost-efficient custom ASIC that reduces logic part count, overall component cost, and board space requirements for PC designers and manufacturers. The Glue Chip 4 supports the latest generation of high-volume

platforms based on Intel® processors and chipsets that require additional external circuitry in order to function properly. It is used on entry servers/workstations (840 and 860 chipsets), high-end desktops (820 and 850 chipsets), as well as mid range (815, 830 and 845 chipsets) and low-end (810 chipset) motherboards. Some of these functionalities include meeting timing specifications, buffering signals, and switching between power wells.

The PCA9504A Glue Chip 4 integrates miscellaneous motherboard logic and analog functions into a single, small footprint 56-pin TSSOP device. The Glue Chip 4 typically resides on the motherboard close to the I/O controller Hub (ICH) and is optimized for the Intel 82801BA I/O controller hub (ICH2).

PIN CONFIGURATION

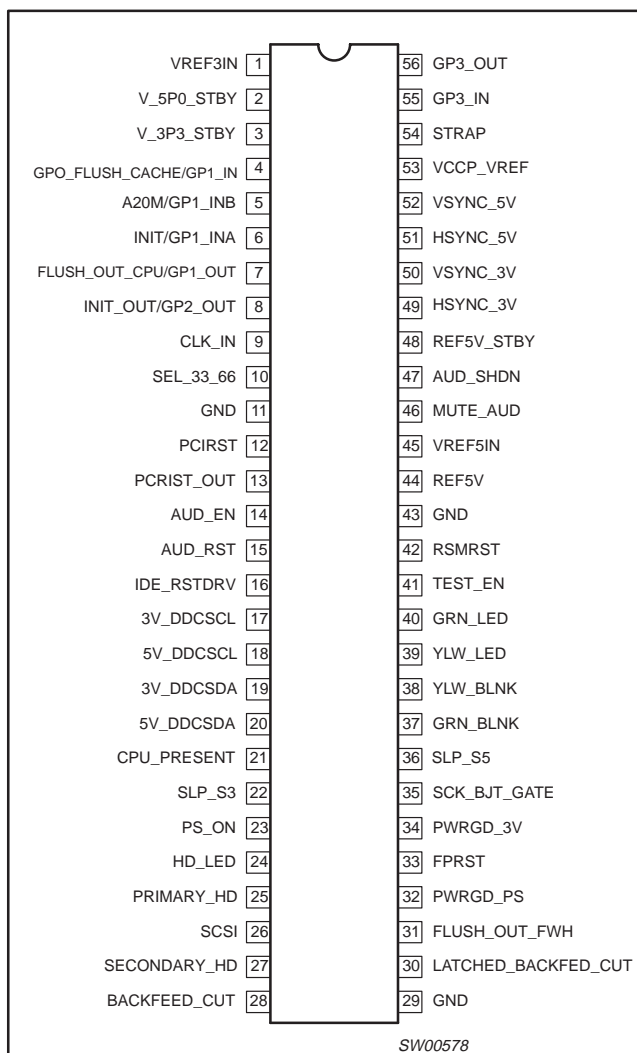

ORDERING INFORMATION

PACKAGE	TEMPERATURE RANGE	ORDER CODE	TOPSIDE MARK	DRAWING NUMBER
56-Pin Plastic TSSOP	0 °C to +70 °C	PCA9504ADGG	PCA9504ADGG	SOT364-1

Standard packing quantities and other packaging data are available at www.philipslogic.com/packaging.

Glue chip 4

PCA9504A

PIN DESCRIPTION

PIN(S)	SYMBOL	FUNCTION	
1	3I	VREF3IN	3.3 V input
2	P	V_5P0_STBY	5 V system standby power supply
3	P	V_3P3_STBY	3 V system standby power supply
4	3IU	GPO_FLUSH_CACHE / GP2_IN	GPO from SIO / ICH2 / Buffer 2 input
5	REF	A20M / GP1_INB	A20M signal from ICH2 / NAND 1 input B
6	REF	INIT / GP1_INA	INIT signal from the ICH2 / Buffer 1 input A
7	5V OD	FLUSH_OUT_CPU / GP1_OUT	Open drain signal, goes to the CPU / NAND 1 output
8	5V OD	INIT_OUT / GP2_OUT	Delayed INIT signal into the CPU / Buffer 2 output
9	3I	CLK_IN	Either 33MHz or 66MHz clock, based on SEL_33_66 pin
10	3IU	SEL_33_66	Strapping option for 33MHz or 66MHz CLK_IN
11, 29, 43	G	GND	Ground
12	3I	PCRIST	PCI reset signal
13	3O	PCRIST_OUT	Copy of PCRIST, increased drive-strength
14	3IU	AUD_EN	Audio enable input (GPO from ICH2 / SIO)
15	3O	AUD_RST	Audio reset output
16	5O	IDE_RSTDRV	IDE reset output, 5 V push/pull
17	3IOD	3V_DDCSCL	DDCSCL input/output 3.3 V side
18	5IOD	5V_DDCSCL	DDCSCL input/output 5 V side
19	3IOD	3V_DDCSDA	DDCSDA input/output 3.3 V side
20	5IOD	5V_DDCSDA	DDCSDA input/output 5 V side
21	3IU	CPU_PRESENT	CPU present signal from the processor
22	3I	SLP_S3	Signal from ICH2 for transitioning to the S3 power state
23	5V OD	PS_ON	Power supply turn-on signal
24	5V OD	HD_LED	Hard drive front panel LED output
25	5IU	PRIMARY_HD	IDE primary drive active input
26	5IU	SCSI	SCSI drive active input
27	5IU	SECONDARY_HD	IDE secondary drive active input
28	5V OD	BACKFEED_CUT	Signal used for STR circuitry
30	5O	LATCHED_BACKFEED_CUT	Signal used for STR circuitry
31	5V OD	FLUSH_OUT_FWH	Open drain signal, goes to the FWH
32	5IU	PWRGD_PS	Power good signal from power supply
33	5IU	FPRST	Reset signal from the front panel
34	3O	PWRGD_3V	3.3 V power good output
35	5V OD	SCK_BJT_GATE	Gate signal from the SCK BJT in suspend to RAM
36	3I	SLP_S5	Signal from the ICH2 for transitioning to the S5 power state
37	3IU	GRN_BLNK	Power LED input, from SIO GPIO
38	3IU	YLW_BLNK	Power LED input, from SIO GPIO
39	5V OD	YLW_LED	Power LED output
40	5V OD	GRN_LED	Power LED output
41	5ID	TEST_EN	Test enable, 100K internal pull-down to GND
42	3O	RSMRST	Reset for the ICH2 resume well
44	AO	REF5V	Highest system supply reference voltage
45	5I	VREF5IN	5V system primary supply input
46	3IU	MUTE_AUD	Signal from SIO to mute audio on power up/down
47	5O	AUD_SHDN	Signal to audio amp to signal shutdown
48	AO	REF5V_STBY	Highest system standby voltage
49	3I	HSYNC_3V	HSYNCH input from chipset video

Glue chip 4

PCA9504A

PIN DESCRIPTION CONTINUED

PIN(S)		SYMBOL	FUNCTION
50	3I	VSYNC_3V	VSYNCH input from chipset video
51	5O	HSYNC_5V	HSYNCH output to monitor
52	5O	VSYNC_5V	VSYNCH output to monitor
53	AI	V _{CCP_VREF}	Analog voltage reference for determining INIT/A20M input thresholds
54	3I/3O	STRAP	Strapping option for GP or FLUSH mode (internal pull-up resistor) Note 1
55	5I	GP3_IN	Generic logic gate 3 input
56	5V OD	GP3_OUT	Generic logic gate 3 output

NOTE:

1. The pin is internally pulled up to default to FLUSH mode.

TYPE	DESCRIPTION
3I	3.3 V input signal
3IU	3.3 V input signal with internal pull-up
5I	5 V input signal
5IU	5 V input signal with internal pull-up
5ID	5 V input signal with internal pull-down
P	Power (input)
G	Ground (input)
3O	3.3 V output signal
5O	5 V output signal
3V OD	3.3 V open-drain output signal
5V OD	5 v open-drain output signal
AO	Analog output
AI	Analog input
3IOD	3.3 V input/output open-drain
5IOD	5 V input/output open-drain
REFL	Input voltage levels referenced to V _{CCP_VREF}

FUNCTION TABLES

Strapping Selection Pin

STRAP (pin 54) ¹	MODE ¹	PIN NAME & (PIN NUMBER)
1 No connect	FLUSH	GPO_FLUSH_CACHE (4)
1 No connect	FLUSH	A20M (5)
1 No connect	FLUSH	INIT (6)
1 No connect	FLUSH	FLUSH_OUT_CPU (7)
1 No connect	FLUSH	INIT_OUT (8)
0 GND	GP	GP2_IN (4)
0 GND	GP	GP1_INB (5)
0 GND	GP	GP1_INA (6)
0 GND	GP	GP1_OUT (7)
0 GND	GP	GP2_OUT (8)

NOTE:

1. The pin is internally pulled up to default to FLUSH mode.

Glue chip 4

PCA9504A

TYPICAL APPLICATION

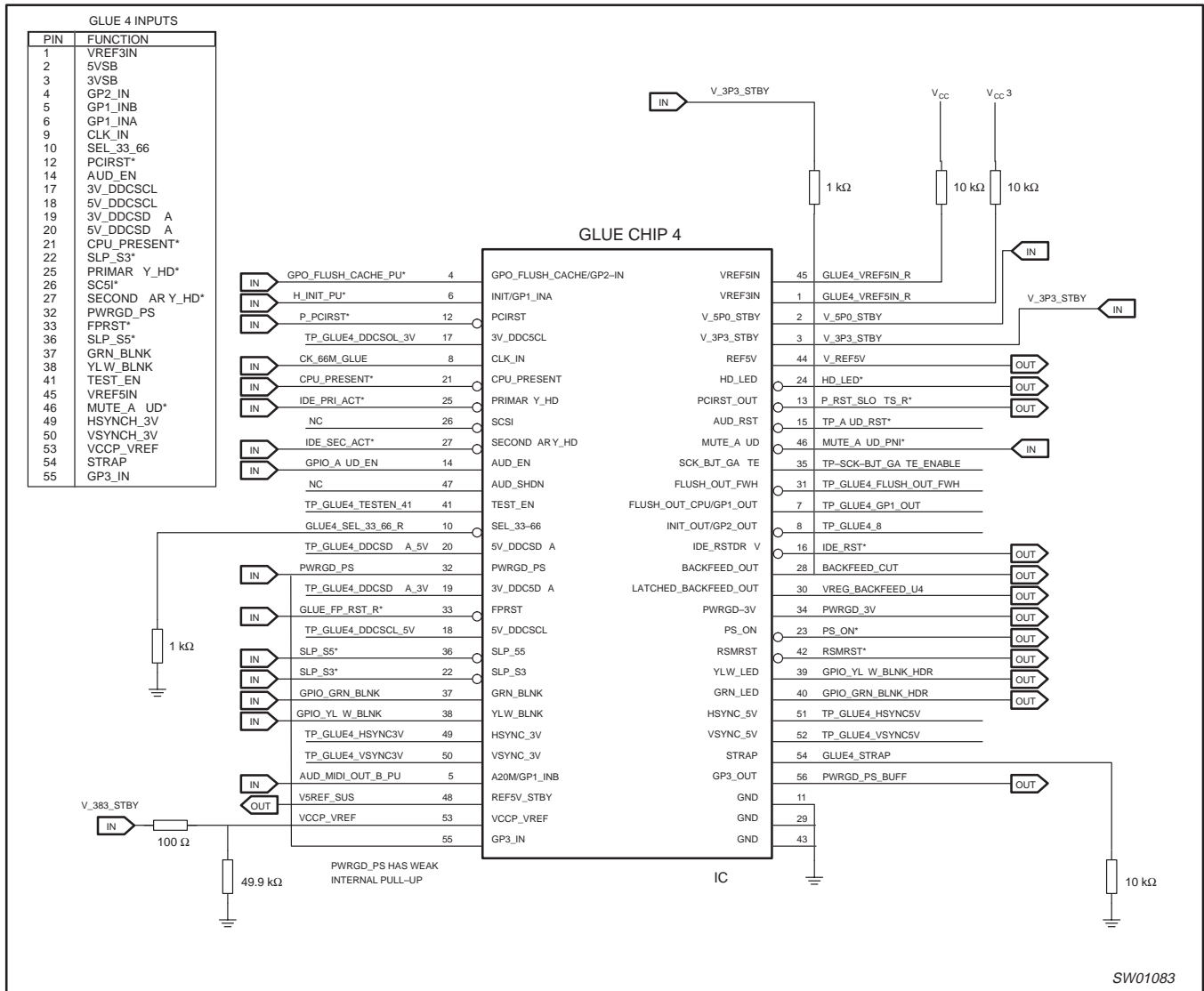

Figure 1. Typical application

Glue chip 4

PCA9504A

ABSOLUTE MAXIMUM RATINGS¹

SYMBOL	PARAMETER	CONDITION	LIMITS		UNIT
			MIN	MAX	
V_5P0_STBY	DC 5.0V supply		-0.5	+6.0	V
V_3P3_STBY	DC 3.3V supply		-0.5	+6.0	V
V _I (5V)	DC input voltage (5 V pins)	Note 2	-0.5	V_5P0_STBY+0.5	V
V _O (5V)	Output voltage range (5 V pins)	Note 2	-0.5	V_5P0_STBY+0.5	V
V _I (3.3V)	DC input voltage (3.3 V pins)	Note 2	-0.5	V_3P3_STBY+0.5	V
V _O (3.3V)	Output voltage range (3.3 V pins)	Note 2	-0.5	V_3P3_STBY+0.5	V
SPD	Supply power dissipation			100	MW
ESD	Static Discharge voltage		2000		V
T _{STG}	Storage temperature range		-55	+150	°C
T _{OTR}	Operating Temperature Range		0	70	°C

NOTES:

- Stresses beyond those listed may cause permanent damage to the device. These are stress ratings only and functional operation of the device at these or any other condition beyond those indicated under "recommended operating condition" is not implied. Exposure to absolute-maximum-rated conditions for extended periods may affect device reliability.
- The input and output voltage rating may be exceeded if the input and output current ratings are observed.

RECOMMENDED OPERATING CONDITIONS

SYMBOL	PARAMETER	CONDITIONS	LIMITS		UNIT
			MIN	MAX	
V _{DD3}	DC 3.3 V supply voltage		3.0	3.6	V
V _{DDL}	DC 2.5 V supply voltage		4.75	5.25	V
V _I	DC input voltage		0	V _{DD3}	V
V _O	DC output voltage		0	V _{DDL} V _{DD3}	V
T _A	Operating ambient temperature range in free air		0	+70	°C

Glue chip 4

PCA9504A

DC CHARACTERISTICS

V_5P0_STBY = 5 V ± 5%; V_3P3_STBY = 3.3 V ± 10%

SYMBOL	PARAMETER	TEST CONDITION	LIMITS			UNIT
			T _{amb} = 0 °C to +70 °C			
			MIN	TYP	MAX	
STRAP						
V _{IH}	HIGH-level input voltage		2.0			V
V _{IL}	LOW-level input voltage				0.8	V
I _{IH}	Input leakage HIGH		-1		1	μA
V _{OL}	LOW-level output voltage	I _{OL} = 6 mA			0.4	V
V _{OH}	HIGH-level output voltage	I _{OH} = -3 mA	2.4			V
I _{IL}	Input leakage LOW		-88		-26	μA
AUD_EN						
V _{IH}	HIGH-level input voltage		2.0			V
V _{IL}	LOW-level input voltage				0.8	V
I _{IL}	Input leakage LOW	V _{IL} = 0 V	-88		-26	μA
I _{IH}	Input leakage HIGH		-1		1	μA
PCIRST						
V _{IH}	HIGH-level input voltage		2.2			V
V _{IL}	LOW-level input voltage				0.8	V
I _L	Input leakage		-1		1	μA
Hys	Input hysteresis		400			mV
MUTE_AUD						
V _{IH}	HIGH-level input voltage		2.2			V
V _{IL}	LOW-level input voltage				0.8	V
I _{IH}	Input leakage HIGH		-1		1	μA
I _{IL}	Input leakage LOW	V _{IL} = 0 V	-88		-26	μA
VREF5IN						
V _{IH}	HIGH-level input voltage		0.85*V5P 0_STBY			V
V _{IL}	LOW-level input voltage				0.2*V5P 0_STBY	V
I _L	Input leakage		-1		1	μA
VREF3IN						
V _{IH}	HIGH-level input voltage		2.2			V
V _{IL}	LOW-level input voltage				0.8	V
I _L	Input leakage		-1		1	μA
PRIMARY_HD						
V _{IH}	HIGH-level input voltage		0.7*5VSB			V
V _{IL}	LOW-level input voltage				0.2*5VSB	V
Hys	Input hysteresis		400			mV
I _{IL}	Input leakage LOW	V _{IL} = 0 V	-88		-26	μA
I _{IH}	Input leakage HIGH	V _{IH} = 5VSB	-1		1	μA
SECONDARY_HD						
V _{IH}	HIGH-level input voltage		0.7*5VSB			V
V _{IL}	LOW-level input voltage				0.2*5VSB	V
Hys	Input hysteresis		400			mV
I _{IL}	Input leakage LOW	V _{IL} = 0 V	-88		-26	μA

Glue chip 4

PCA9504A

SYMBOL	PARAMETER	TEST CONDITION	LIMITS			UNIT
			$T_{amb} = 0\text{ }^{\circ}\text{C to } +70\text{ }^{\circ}\text{C}$			
			MIN	TYP	MAX	
I_{IH}	Input leakage HIGH	$V_{IH} = 5V_{SB}$	-1		1	μA
SCSI						
V_{IH}	HIGH-level input voltage		$0.7 \cdot 5V_{SB}$			V
V_{IL}	LOW-level input voltage				$0.2 \cdot 5V_{SB}$	V
Hys	Input hysteresis		400			mV
I_{IL}	Input leakage LOW	$V_{IL} = 0\text{ V}$	-88		-26	μA
I_{IH}	Input leakage HIGH	$V_{IH} = 5V_{SB}$	-1		1	μA
FPRST						
V_{IH}	HIGH-level input voltage		$0.7 \cdot 5V_{SB}$			V
V_{IL}	LOW-level input voltage				$0.2 \cdot 5V_{SB}$	V
Hys	Input hysteresis		400			mV
I_{IL}	Input leakage LOW	$V_{IL} = 0\text{ V}$	-88		-26	μA
I_{IH}	Input leakage HIGH	$V_{IH} = 5V_{SB}$	-1		1	μA
PWRGD_PS						
V_{IH}	HIGH-level input voltage		$0.7 \cdot 5V_{SB}$			V
V_{IL}	LOW-level input voltage				$0.2 \cdot 5V_{SB}$	V
Hys	Input hysteresis		400			mV
I_{IL}	Input leakage LOW	$V_{IL} = 0\text{ V}$	-88		-26	μA
I_{IH}	Input leakage HIGH	$V_{IH} = 5V_{SB}$	-1		1	μA
GPO_FLUSH_CACHE/GP2_IN						
V_{IH}	HIGH-level input voltage		2.2			V
V_{IL}	LOW-level input voltage				0.8	V
I_L	Input leakage	$V_{IL} = 0\text{ V}$	-88		-26	μA
I_{IH}	Input leakage	$V_{IH} = 5\text{ V}$	-1		1	μA
INIT / GP1_INA (GP Mode)						
V_{IH}	HIGH-level input voltage	Part is strapped for GP mode	2.4			V
V_{IL}	LOW-level input voltage	Part is strapped for GP mode			0.8	V
I_L	Input leakage	Part is strapped for GP mode	-1		1	μA
$V_{CCP_V_{ref}}$	Bias voltage	GP mode	1.95		2.1	V
INIT / GP1_INA (Flush Mode)						
V_{IH}	HIGH-level input voltage	FLUSH mode	1.5			V
V_{IL}	LOW-level input voltage	FLUSH mode			0.4	V
I_{IL}	Input leakage	FLUSH mode	-1		1	μA
$V_{CCP_V_{ref}}$	Bias voltage	FLUSH mode	0.95		1.1	V

Glue chip 4

PCA9504A

SYMBOL	PARAMETER	TEST CONDITION	LIMITS			UNIT
			$T_{amb} = 0\text{ }^{\circ}\text{C to }+70\text{ }^{\circ}\text{C}$			
			MIN	TYP	MAX	
A20M / GP1_INB						
V_{IH}	HIGH-level input voltage	FLUSH mode	1.5			V
V_{IL}	LOW-level input voltage	FLUSH mode			0.4	V
I_{IL}	Input leakage	FLUSH mode	-1		1	μA
$V_{CCP_V_{ref}}$	Bias voltage	FLUSH mode	0.95		1.1	V
V_{IH}	HIGH-level input voltage	GP mode	2.4			V
V_{IL}	LOW-level input voltage	GP mode			0.8	V
I_L	Input leakage	GP mode	-1		1	μA
$V_{CCP_V_{ref}}$	Bias voltage	GP mode	1.95		2.1	V
CLK_IN						
V_{IH}	HIGH-level input voltage		2.2			V
V_{IL}	LOW-level input voltage				0.8	V
Hys	Input hysteresis		250			mV
I_L	Input leakage		-1		1	μA
SEL_33_66						
V_{IH}	HIGH-level input voltage		2.0			V
V_{IL}	LOW-level input voltage				0.8	V
Hys	Input hysteresis		400			mV
I_{IH}	Input leakage		-1		1	μA
I_{IL}	Input leakage	$V_{IL} = 0\text{ V}$	-88		-26	μA
SLP_S3						
V_{IH}	HIGH-level input voltage		2.2			V
V_{IL}	LOW-level input voltage				0.8	V
Hys	Input hysteresis		400			mV
I_L	Input leakage		-1		1	μA
SLP_S5						
V_{IH}	HIGH-level input voltage		2.2			V
V_{IL}	LOW-level input voltage				0.8	V
Hys	Input hysteresis		400			mV
I_L	Input leakage		-1		1	μA
CPU_PRESENT						
V_{IH}	HIGH-level input voltage		2.0			V
V_{IL}	LOW-level input voltage				0.8	V
Hys	Input hysteresis		400			mV
I_{IH}	Input leakage	$V_{IH} = 3V_{SB}$	-1		1	μA
I_{IL}	Input leakage	$V_{IL} = 0\text{ V}$	-88		-26	μA
TEST_EN						
V_{IH}	HIGH-level input voltage		$0.7 \cdot 5V_{SB}$			V
V_{IL}	LOW-level input voltage				$0.2 \cdot 5V_{SB}$	V
Hys	Input hysteresis		400			mV
I_{IH}	Input leakage	$V_{IL} = 0\text{ V}$	-1		1	μA
I_{IL}	Input leakage	$V_{IH} = 5V_{SB}$	20		88	μA

Glue chip 4

PCA9504A

SYMBOL	PARAMETER	TEST CONDITION	LIMITS			UNIT
			$T_{amb} = 0\text{ }^{\circ}\text{C to }+70\text{ }^{\circ}\text{C}$			
			MIN	TYP	MAX	
HSYNC_3V						
V_{IH}	HIGH-level input voltage		2.2			V
V_{IL}	LOW-level input voltage				0.8	V
I_L	Input leakage		-1		1	μA
VSYNC_3V						
V_{IH}	HIGH-level input voltage		2.2			V
V_{IL}	LOW-level input voltage				0.8	V
I_L	Input leakage		-1		1	μA
GRN_BLNK						
V_{IH}	HIGH-level input voltage		2.2			V
V_{IL}	LOW-level input voltage				0.8	V
I_{IH}	Input leakage		-1		1	μA
I_{IL}	Input leakage	$V_{IL} = 0\text{ V}$	-88		-26	μA
YLW_BLNK						
V_{IH}	HIGH-level input voltage		2.0			V
V_{IL}	LOW-level input voltage				0.8	V
I_{IH}	Input leakage		-1		1	μA
I_{IL}	Input leakage	$V_{IL} = 0\text{ V}$	-88		-26	μA
GP3_IN						
V_{IH}	HIGH-level input voltage		2.2			V
V_{IL}	LOW-level input voltage				0.8	V
I_L	Input leakage		-1		1	μA
AUD_RST						
V_{OL}	LOW-level output voltage	$I_{OL} = 6\text{ mA}$			0.4	V
V_{OH}	HIGH-level output voltage	$I_{OH} = -3\text{ mA}$	2.4			V
I_{OZ}	Off state output current		-1		1	μA
AUD_SHDN						
V_{OL}	LOW-level output voltage	$I_{OL} = 6\text{ mA}$			0.4	V
V_{OH}	HIGH-level output voltage	$I_{OH} = -6\text{ mA}$	2.4			V
I_{OZ}	Off state output current		-1		1	μA
REF5V						
V_{OUT5}	LOW-level output voltage	$V_{REF5in} > 1.5\text{ V}$	$V_{REF5in} - 0.05$		$V_{REF5in} + 0.05$	V
V_{OUT3}	HIGH-level output voltage	$V_{REF3in} > 1.5\text{ V}$	$V_{REF3in} - 0.05$		$V_{REF3in} + 0.05$	V
I_{OUTL}	Off state output current		-20		20	μA
REF5V_STBY						
V_{OUT5}	LOW-level output voltage	$V_{_5P0_STBY} > 1.5\text{ V}$	$V_{_5P0_STBY} - 0.05$		$V_{_5P0_STBY} + 0.05$	V
V_{OUT3}	HIGH-level output voltage	$V_{_5P0_STBY} > 1.5\text{ V}$	$V_{_5P0_STBY} - 0.05$		$V_{_5P0_STBY} + 0.05$	V
I_{OUTL}	Off state output current		-20		20	μA
HD_LED						
V_{OL}	LOW-level output voltage	$I_{OL} = 12\text{ mA}$			0.4	V
I_{OZ}	Off state output current		-1		1	μA

Glue chip 4

PCA9504A

SYMBOL	PARAMETER	TEST CONDITION	LIMITS			UNIT
			$T_{amb} = 0\text{ }^{\circ}\text{C to }+70\text{ }^{\circ}\text{C}$			
			MIN	TYP	MAX	
IDE_RSTDRV						
V _{OL}	LOW-level output voltage	I _{OL} = 6 mA			0.4	V
V _{OH}	HIGH-level output voltage	I _{OH} = -6 mA	2.4			V
I _{OZ}	Off state output current		-1		1	μA
PCIRST_OUT						
V _{OL}	LOW-level output voltage	I _{OL} = 6 mA			0.4	V
V _{OH}	HIGH-level output voltage	I _{OH} = -3 mA	2.4			V
I _{OZ}	Off state output current		-1		1	μA
PRWGD_3V						
V _{OL}	LOW-level output voltage	I _{OL} = 6 mA			0.4	V
V _{OH}	HIGH-level output voltage	I _{OH} = -3 mA	2.4			V
I _{OZ}	Off state output current		-1		1	μA
INIT_OUT / GP2_OUT						
V _{OL}	LOW-level output voltage	I _{OL} = 12 mA			0.4	V
I _{OZ}	Off state output current		-1		1	μA
FLUSH_OUT_CPU / GP1_OUT						
V _{OL}	LOW-level output voltage	I _{OL} = 12 mA			0.4	V
I _{OZ}	Off state output current		-1		1	μA
BACKFEED_CUT						
V _{OL}	LOW-level output voltage	I _{OL} = 6 mA			0.4	V
I _{OZ}	Off state output current		-1		1	μA
FLUSH_OUT_FWH						
V _{OL}	LOW-level output voltage	I _{OL} = 6 mA			0.4	V
I _{OZ}	Off state output current		-1		1	μA
LATCHED_BACKFEED_CUT						
V _{OL}	LOW-level output voltage	I _{OL} = 6 mA			0.4	V
V _{OH}	HIGH-level output voltage	I _{OH} = -6 mA	2.4			V
I _{OZ}	Off state output current		-1		1	μA
PS_ON						
V _{OL}	LOW-level output voltage	I _{OL} = 6 mA			0.4	V
I _{OZ}	Off state output current		-1		1	μA
RSMRST						
V _{OL}	LOW-level output voltage	I _{OL} = 6 mA			0.4	V
V _{OH}	HIGH-level output voltage	I _{OH} = -3 mA	2.4			V
I _{OZ}	Off state output current		-1		1	μA
VTRIP	5VSB LOW trip voltage		1.8		3.5	V
SCK_BJT_GATE						
V _{OL}	LOW-level output voltage	I _{OL} = 6 mA			0.4	V
I _{OZ}	Off state output current		-1		1	μA

Glue chip 4

PCA9504A

SYMBOL	PARAMETER	TEST CONDITION	LIMITS			UNIT
			$T_{amb} = 0\text{ }^{\circ}\text{C to }+70\text{ }^{\circ}\text{C}$			
			MIN	TYP	MAX	
3V_DDCSDA						
V_{OL}	LOW-level output voltage	$I_{OL} = 6\text{ mA}$			0.4	V
I_H	Input leakage	$5V_DDCSDA = V_{DD}$	-1		2.5	μA
I_{OZ}	Off state output current		-1		1	μA
5V_DDCSDA						
V_{OL}	LOW-level output voltage	$I_{OL} = 6\text{ mA}$			0.4	V
I_H	Input leakage	$3V_DDCSDA = V_{DD}$	-1		2.5	μA
I_{OZ}	Off state output current		-1		1	μA
3V_DDCSCL						
V_{OL}	LOW-level output voltage	$I_{OL} = 6\text{ mA}$			0.4	V
I_H	Input leakage	$5V_DDCSCL = V_{DD}$	-1		2.5	μA
I_{OZ}	Off state output current		-1		1	μA
5V_DDCSCL						
V_{OL}	LOW-level output voltage	$I_{OL} = 6\text{ mA}$			0.4	V
I_H	Input leakage	$3V_DDCSCL = V_{DD}$	-1		2.5	μA
I_{OZ}	Off state output current		-1		1	μA
HSYNC_5V						
V_{OL}	LOW-level output voltage	$I_{OL} = 6\text{ mA}$			0.4	V
V_{OH}	HIGH-level output voltage	$I_{OH} = -6\text{ mA}$	3.8			V
I_{OZ}	Off state output current		-1		1	μA
VSYNC_5V						
V_{OL}	LOW-level output voltage	$I_{OL} = 6\text{ mA}$			0.4	V
V_{OH}	HIGH-level output voltage	$I_{OH} = -6\text{ mA}$	3.8			V
I_{OZ}	Off state output current		-1		1	μA
GRN_LED / YLW_LED						
V_{OL}	LOW-level output voltage	$I_{OL} = 24\text{ mA}$			0.4	V
I_{OZ}	Off state output current		-1		1	μA
GP3_OUT						
V_{OL}	LOW-level output voltage	$I_{OL} = 6\text{ mA}$				
I_{OZ}	Off state output current		-1		1	μA

Glue chip 4

PCA9504A

AC CHARACTERISTICSV_{CC1} = 3.3 V; V_{CC} = 5.0 V

SYMBOL	PARAMETER	LIMITS			UNITS	NOTES
		T _{amb} = 0 °C to +70 °C				
		MIN	TYP	MAX		
t _{RESET}	RSMRST	4.0		100	ms	
t _{RESET_FALL}	RSMRST			100	ns	
t _{PHL} /t _{PLH}	Propagation Delay AUD_EN to AUD_RST PCIRST to AUD_RST PCIRST to IDE_RSTDRV PCIRST to PCIRST_OUT	1.0		11.0	ns	
t _{PLH} /t _{PHL}	Propagation Delay MUTE_AUD to MUTE_SHDN	2.5		6.0	ns	
t _{PLH} /t _{PHL}	Propagation Delay PWRGD_PS to PWRGD_3V FPRST to PWRGD_3V	4.5		11.0	ns	
t _{PLH} /t _{PHL}	Propagation Delay HSYNC_3V to HSYNC_5V VSYNC_3V to VSYNC_5V	2.0		5.0	ns	
t _{PLH} /t _{PHL}	Propagation Delay PWRGD_PS to SCK_BJT_GATE FPRST to SCK_BJT_GATE	1.0		6.0	ns	
t _{PLZ} /t _{PZL}	Open Drain Prop Delay PRIMARY_HD to HD_LED PRIMARY_HD to HD_LED PRIMARY_HD to HD_LED	1.0		5.0	ns	
t _{PLZ} /t _{PZL}	Open Drain Prop Delay GP1_INA to GP1_OUT GP2_INA to GP1_OUT	3.0		25.0	ns	
t _{PLZ} /t _{PZL}	Open Drain Prop Delay GP2_IN to GP2_OUT	3.0		7.0	ns	
t _{PLZ} /t _{PZL}	Open Drain Prop Delay GP3_IN to GP3_OUT	1.0		4.0	ns	
t _{PLZ} /t _{PZL}	Open Drain Prop Delay SLP_S3 to BACKFEED_OUT PRWGD_PS to BACKFEED_OUT	1.0		6.0	ns	
t _{PLZ} /t _{PZL}	Open Drain Prop Delay CPU_PRESENT to PS_ON	2.0		10.0	ns	
t _{PLZ} /t _{PZL}	Open Drain Prop Delay SLP_S3 to PS_ON	2.0		10.0	ns	
t _{PLZ} /t _{PZL}	Open Drain Prop Delay BACKFEED_OUT to LATCHED_BACKFEED_OUT	2.0		11.0	ns	
t _{PLZ} /t _{PZL}	Open Drain Prop Delay SLP_S5 to YLW_LED SLP_S5 to GRN_LED YLW_BLNK to YLW_LED GRN_BLNK to GRN_LED	1.0		5.0	ns	
t _{PLZ} /t _{PZL}	Open Drain Prop Delay 3V_DDOSDA to 5V_DDOSDA 3V_DDOSDA to 5V_DDOSDA	1.0		5.0	ns	
t _r , t _f	Rise and Fall Times HSYNC_5V VSYNC_5V	3.5			ns	
t _r , t _f	Rise and Fall Times LATCHED_BACKFEED_OUT			1.0	µs	

Glue chip 4

PCA9504A

WAVEFORMS

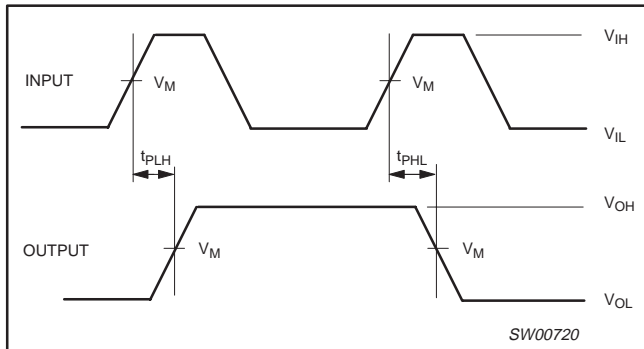

Waveform 1.

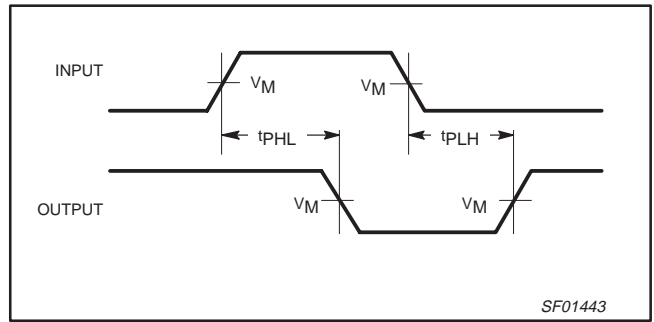

Waveform 3.

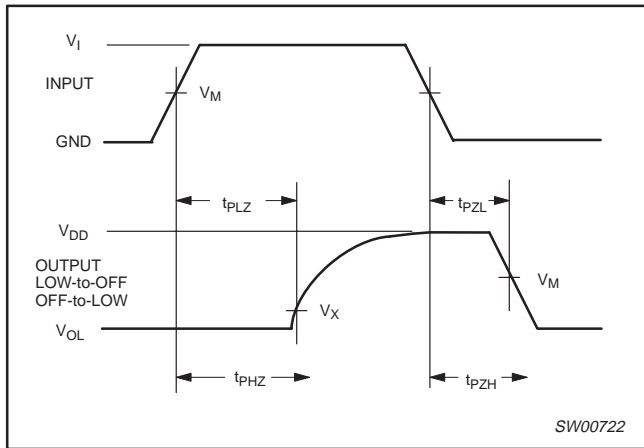

Waveform 2.

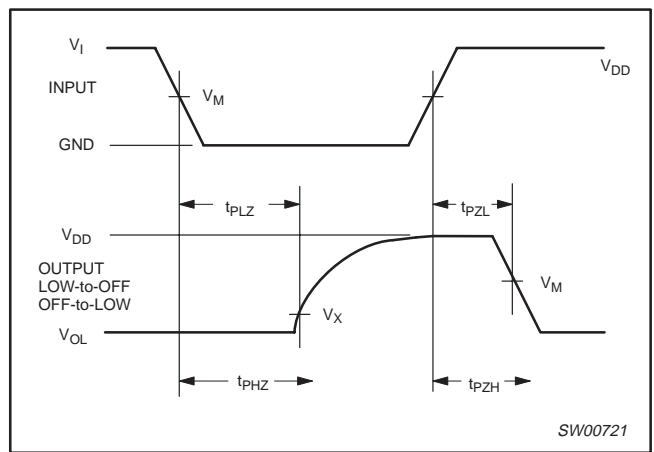

Waveform 4.

Glue chip 4

PCA9504A

5V REFERENCE GENERATION

Supply	REF5V
$V_{REF5IN} < V_{REF3IN}$	V_{REF3IN}
$V_{REF5IN} > V_{REF3IN}$	V_{REF5IN}

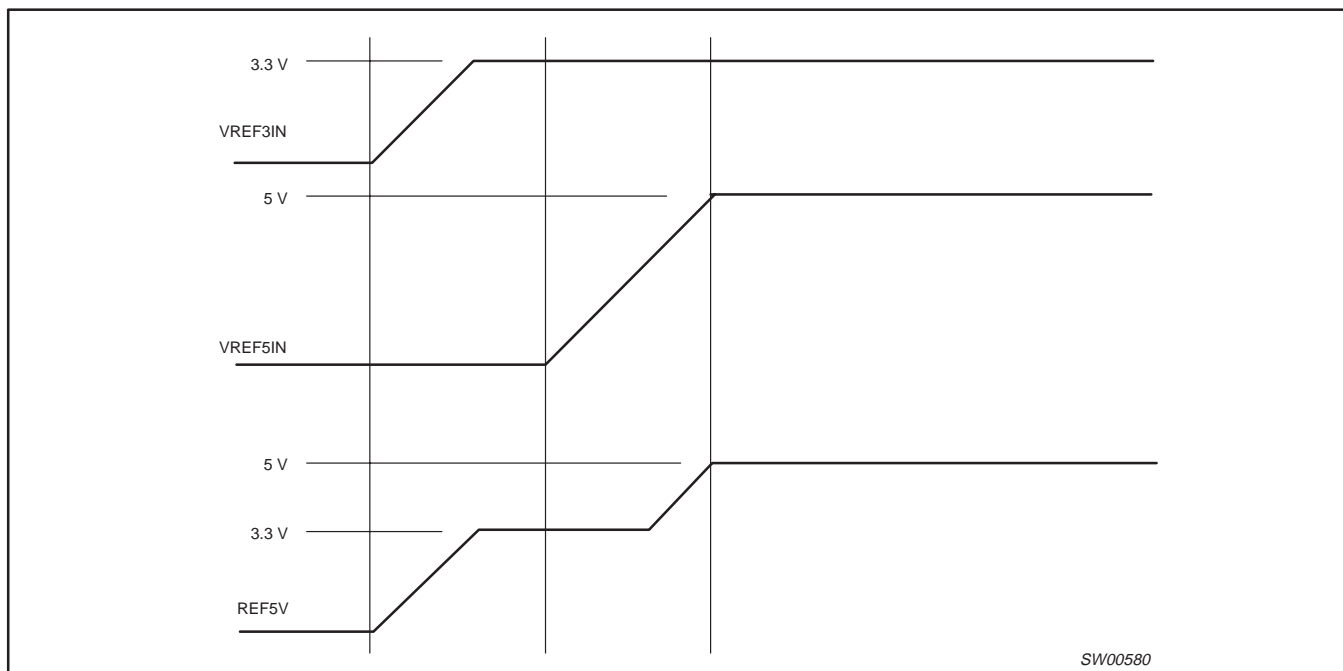

Figure 1. REF5V when VREF3IN ramps before VREF5IN

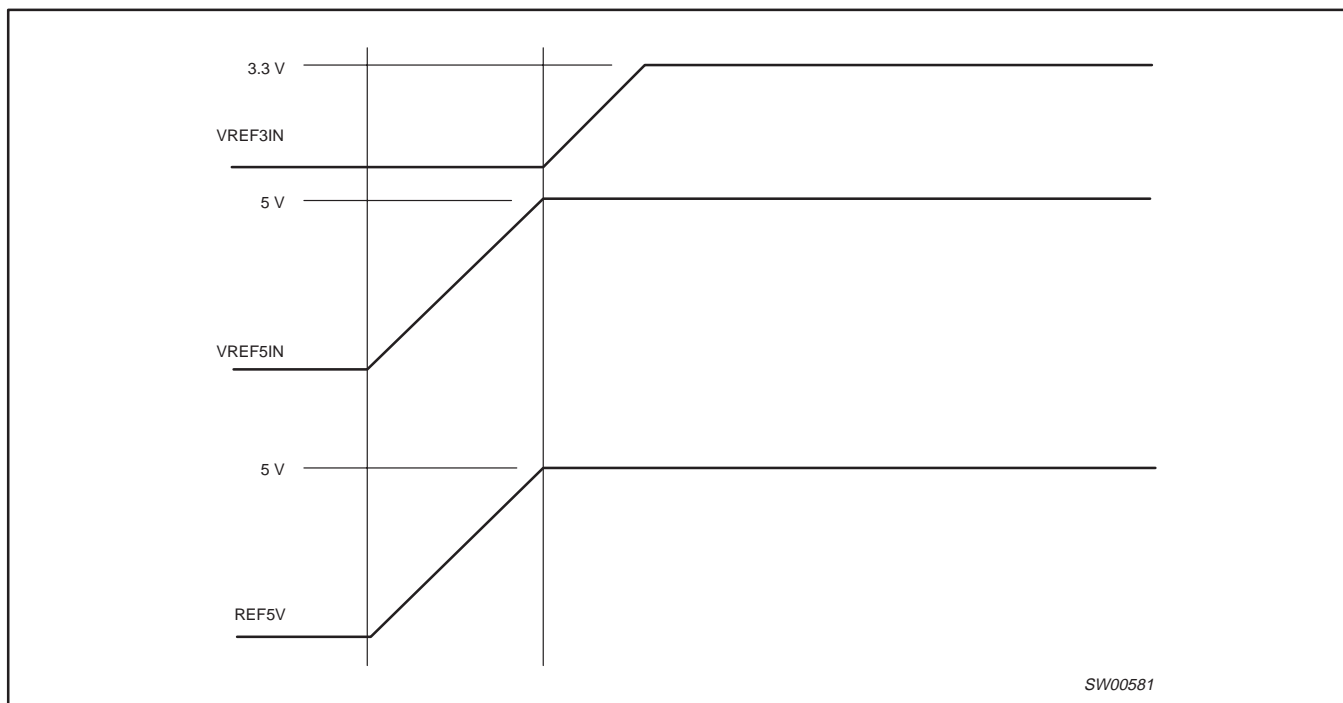

Figure 2. REF5V when VREF5IN ramps before VREF3IN

Glue chip 4

PCA9504A

5V STANDBY REFERENCE GENERATION

Standby Supply	REF5V_STBY
$V_{5PO_STBY} < V_{3P3_STBY}$	V_{3P3_STBY}
$V_{5PO_STBY} > V_{3P3_STBY}$	V_{5PO_STBY}

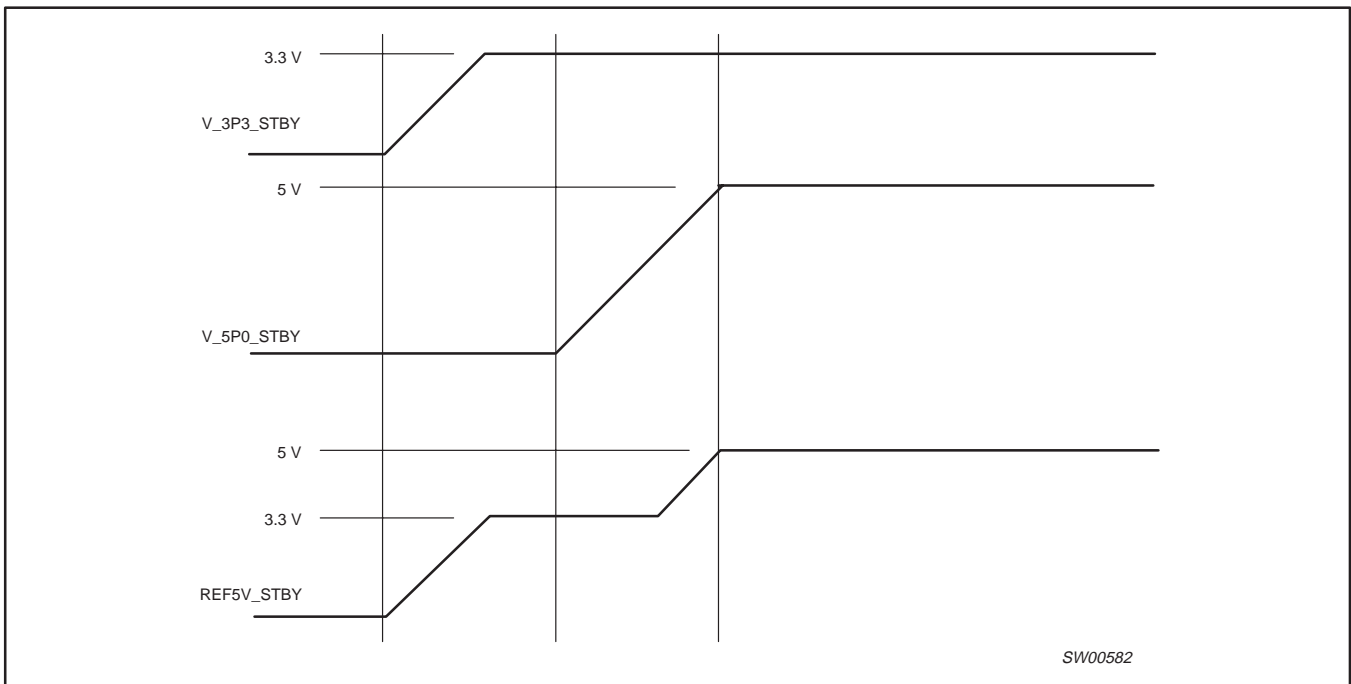

Figure 3. REF5V_STBY when V_3P3_STBY ramps before V_5PO_STBY

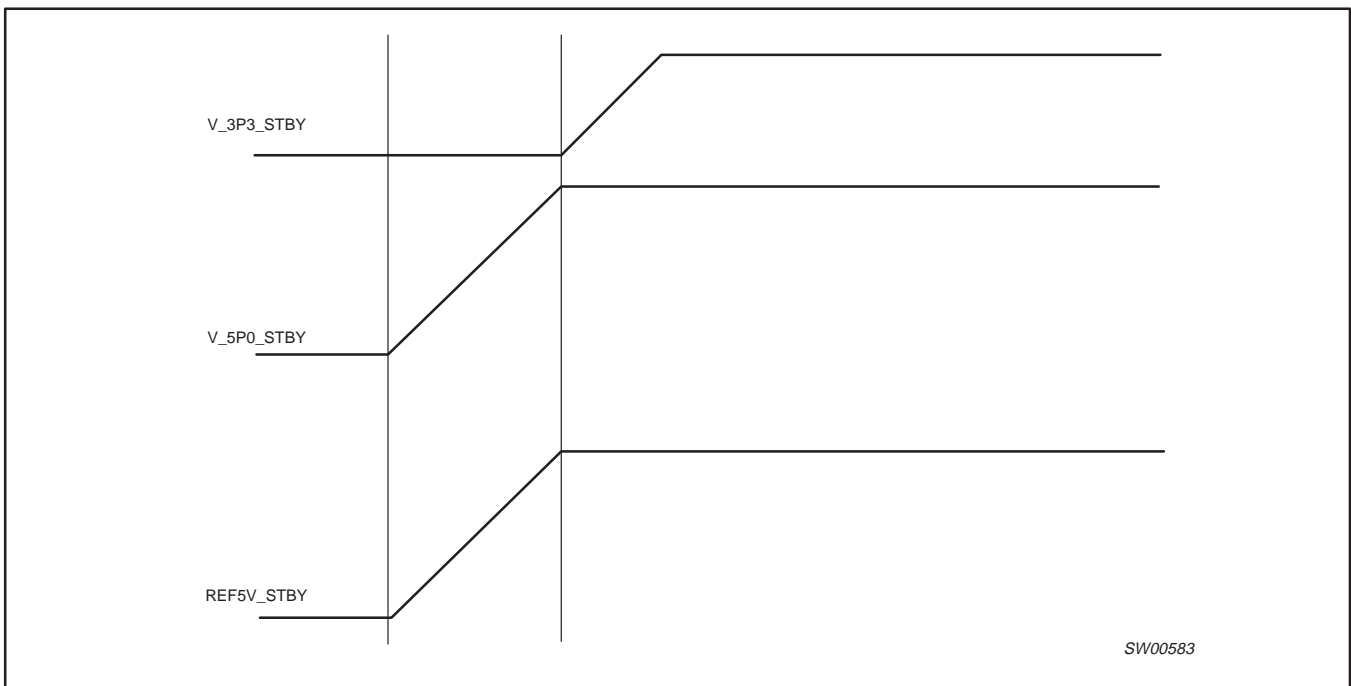

Figure 4. REF5V_STBY when V_5PO_STBY ramps before V_3P3_STBY

Glue chip 4

PCA9504A

FLUSH OUT* / INIT OUT* CIRCUIT

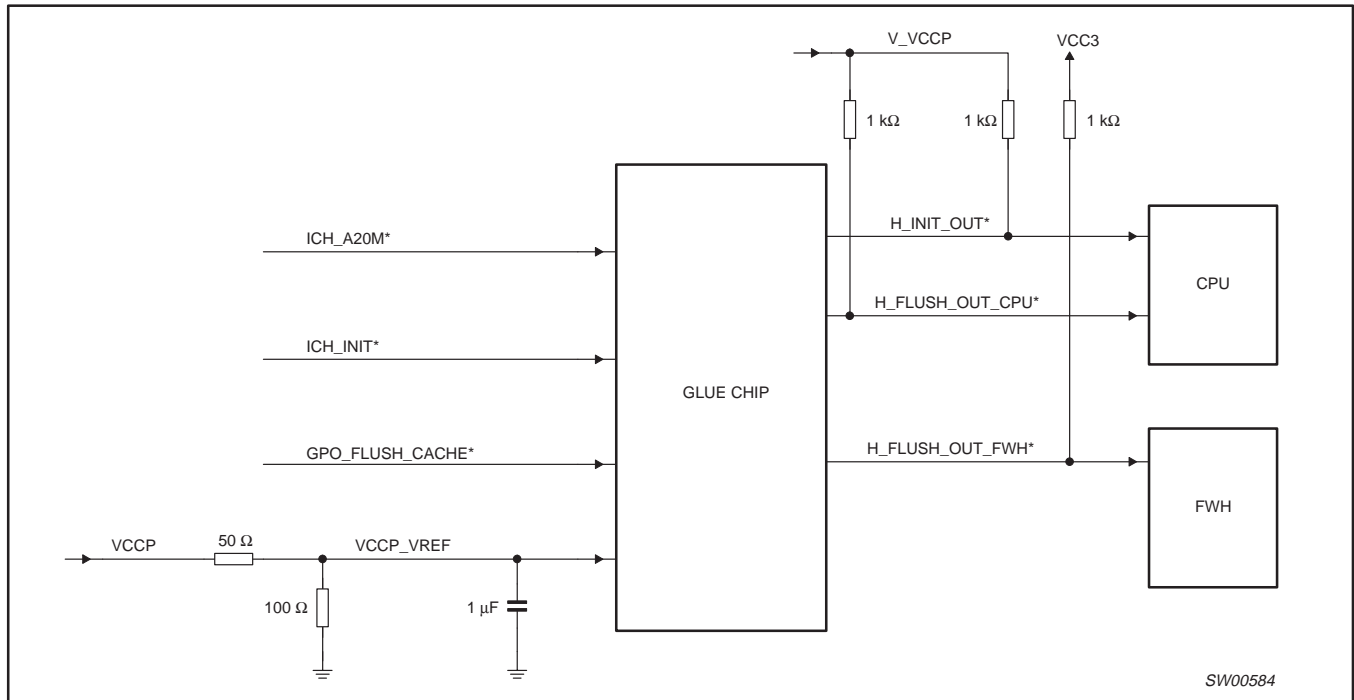

Figure 5. Block diagram for FLUSH_OUT*/INIT_OUT* circuit

Case	A20M*	GPO FLUSH CACHE*	INIT*	FLUSH OUT CPU*	FLUSH OUT FWH*	INIT OUT*
1	1	falling edge	0	0 (for t1)	0 (for t1)	0, Hi-Z, then 0 (delayed by t1-t, then active for 2*t)
2	1	falling edge	1	0 (for t1)	0 (for t1)	Hi-Z, 0 (delayed by t1-t, then active for 2*t)
3	X	1	0	Hi-Z	Hi-Z	0
4	X	1	1	Hi-Z	Hi-Z	Hi-Z
5	0	falling edge	1	Hi-Z	Hi-Z	Hi-Z
6	0	falling edge	0	Hi-Z	Hi-Z	0

NOTE:

- Nominal value timings with tolerances are listed in the DC Characteristics table for t and t1. All Hi-Z outputs are shown as 1's or HIGH in the following diagrams.

Glue chip 4

PCA9504A

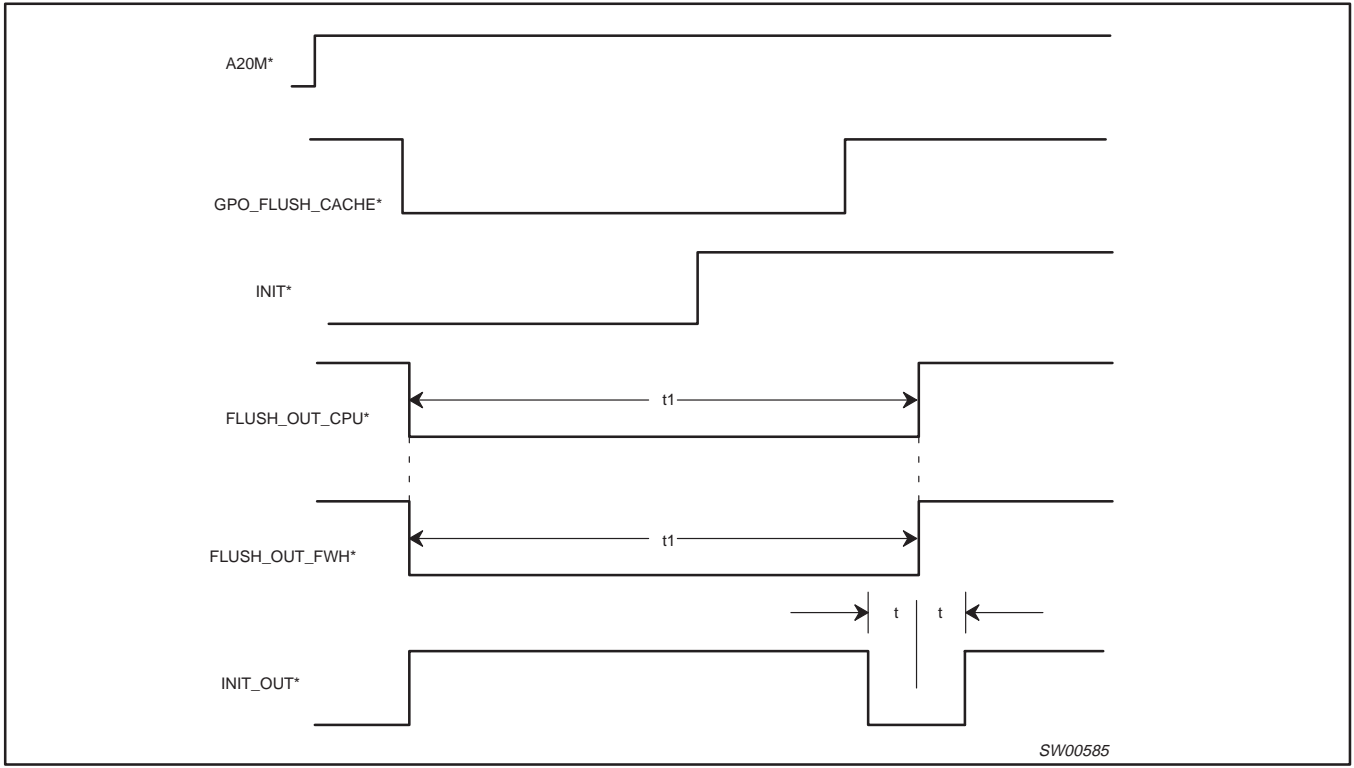

Figure 6. Waveforms for Case 1

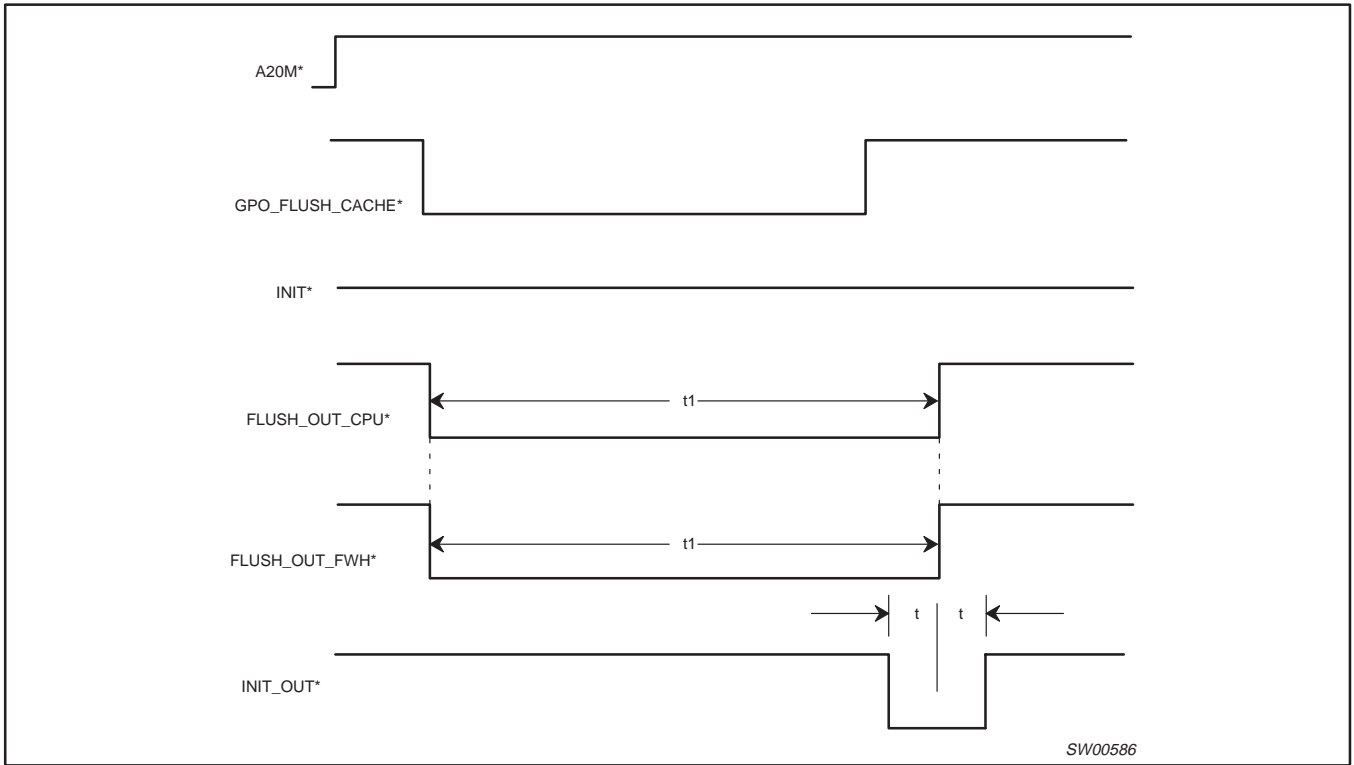

Figure 7. Waveforms for Case 2

Glue chip 4

PCA9504A

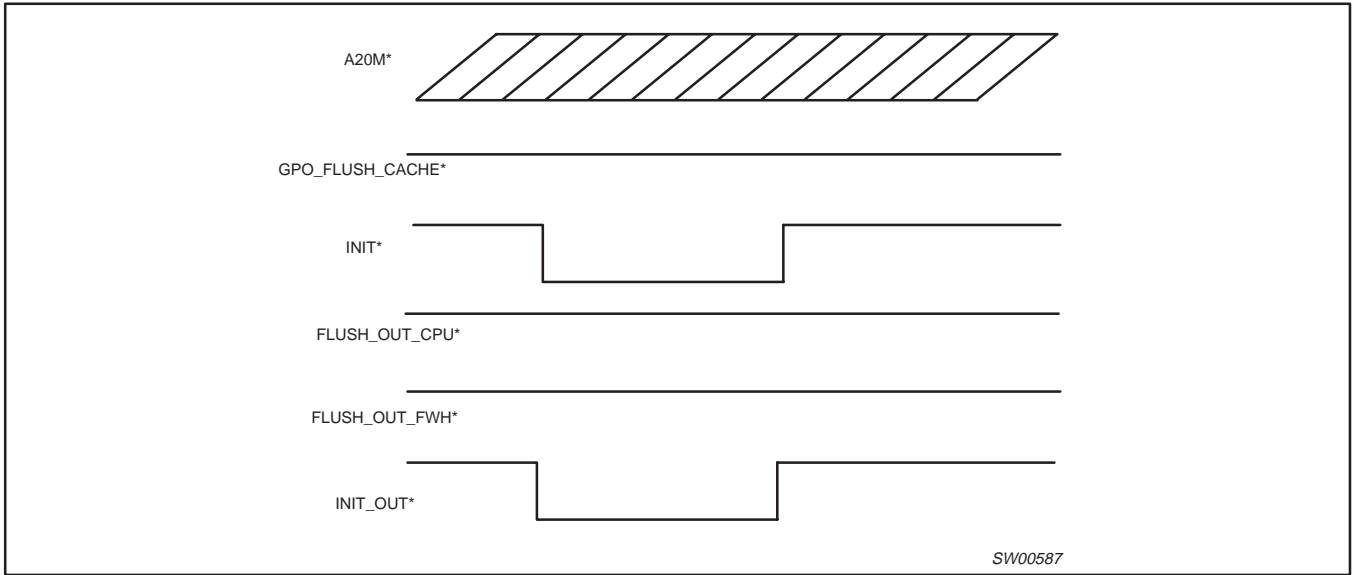

Figure 8. Waveforms for Case 3

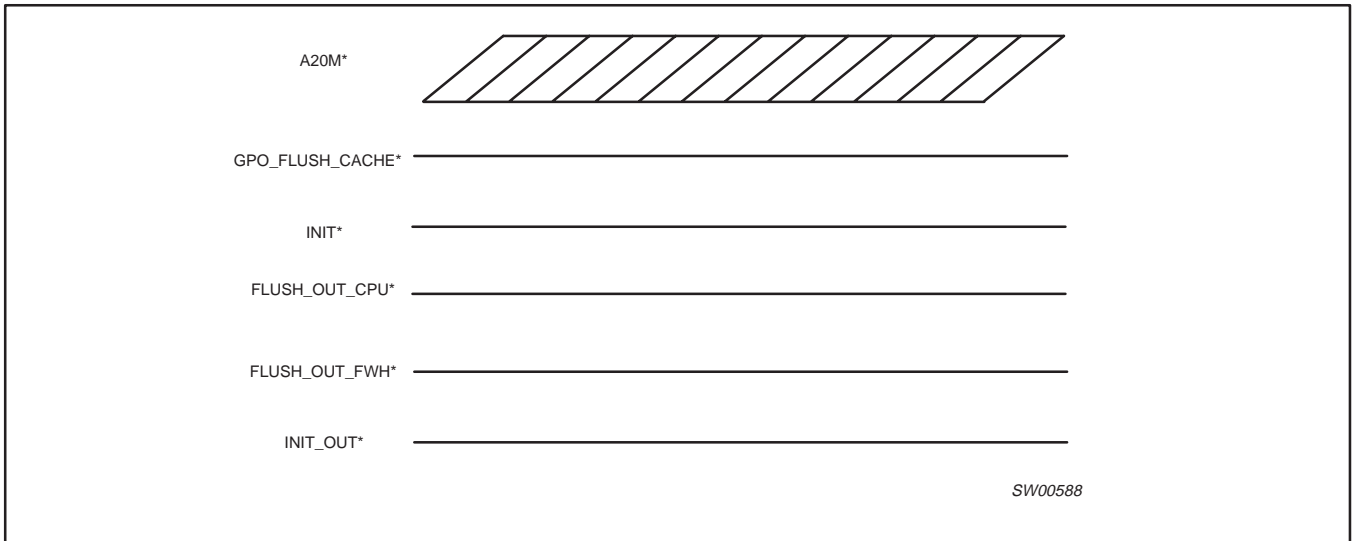

Figure 9. Waveforms for Case 4

Glue chip 4

PCA9504A

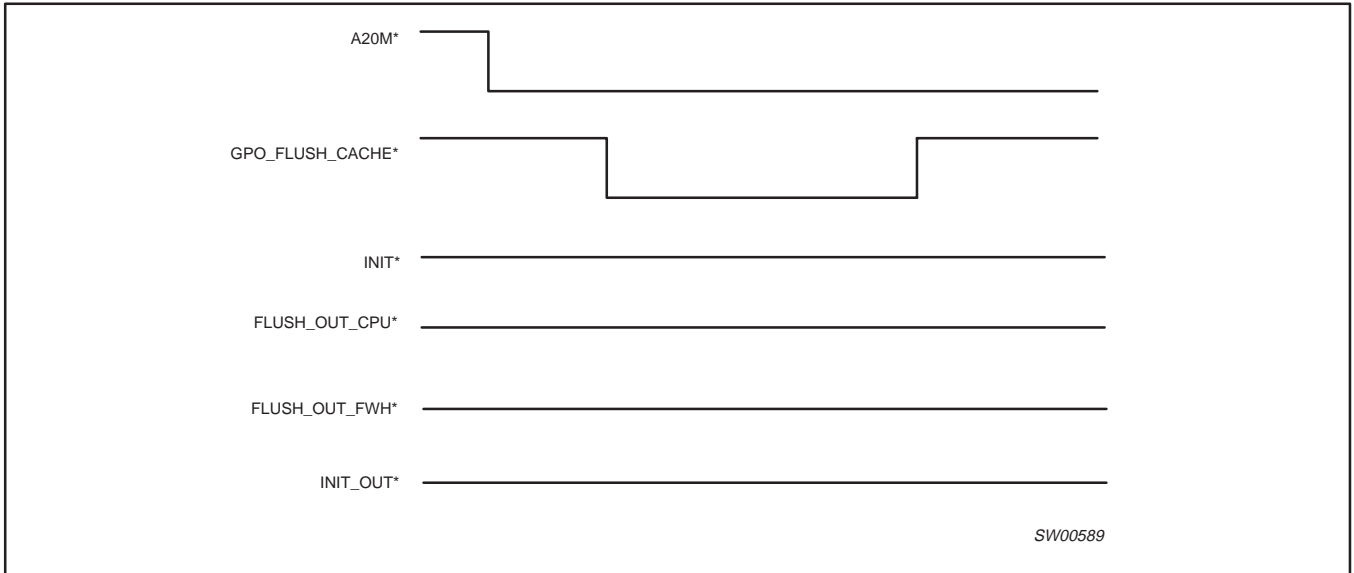

Figure 10. Waveforms for Case 5

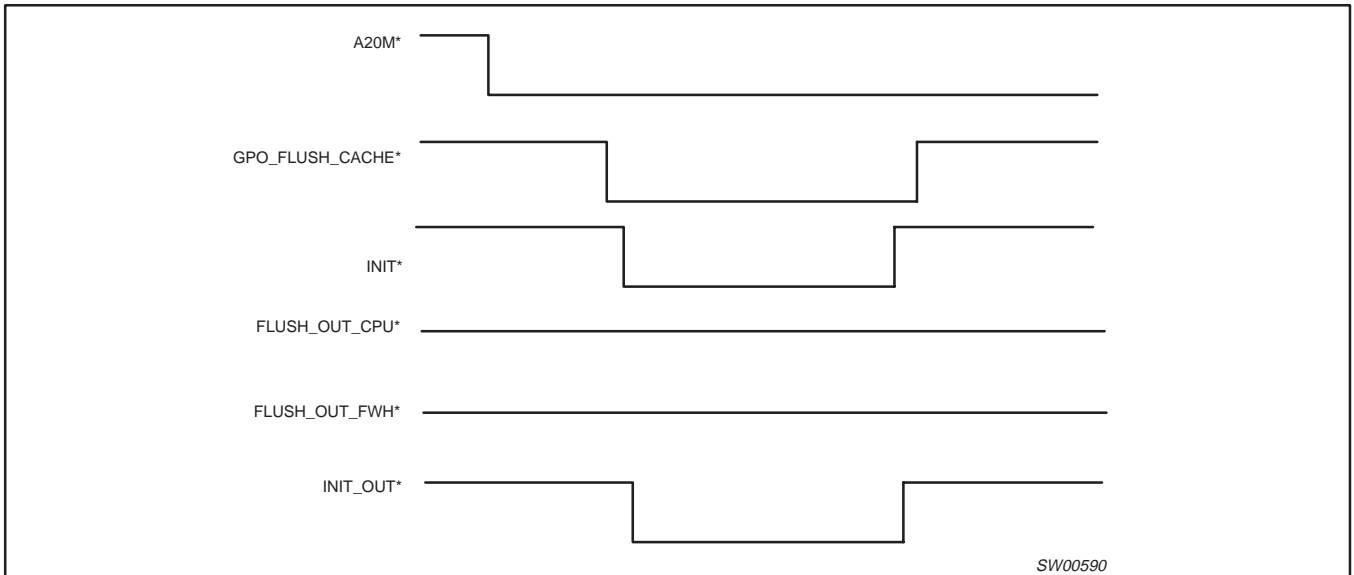

Figure 11. Waveforms for Case 6

Glue chip 4

PCA9504A

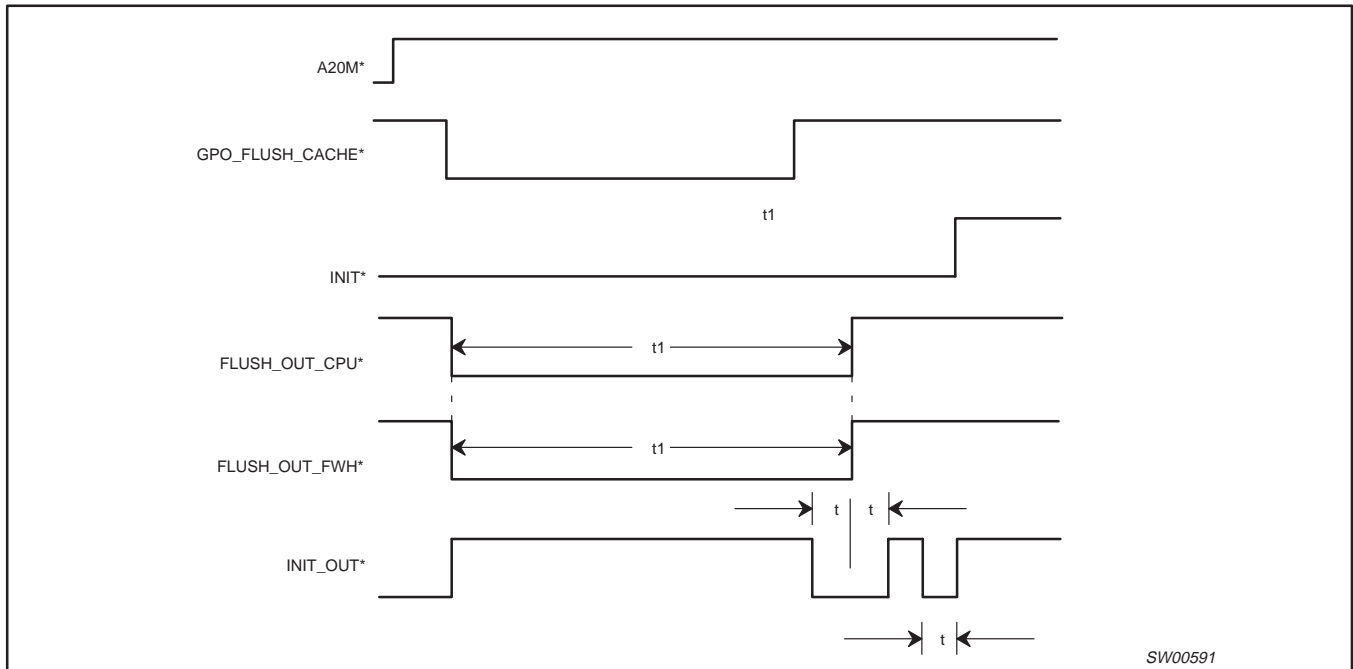

Figure 12. Waveforms for Case 7

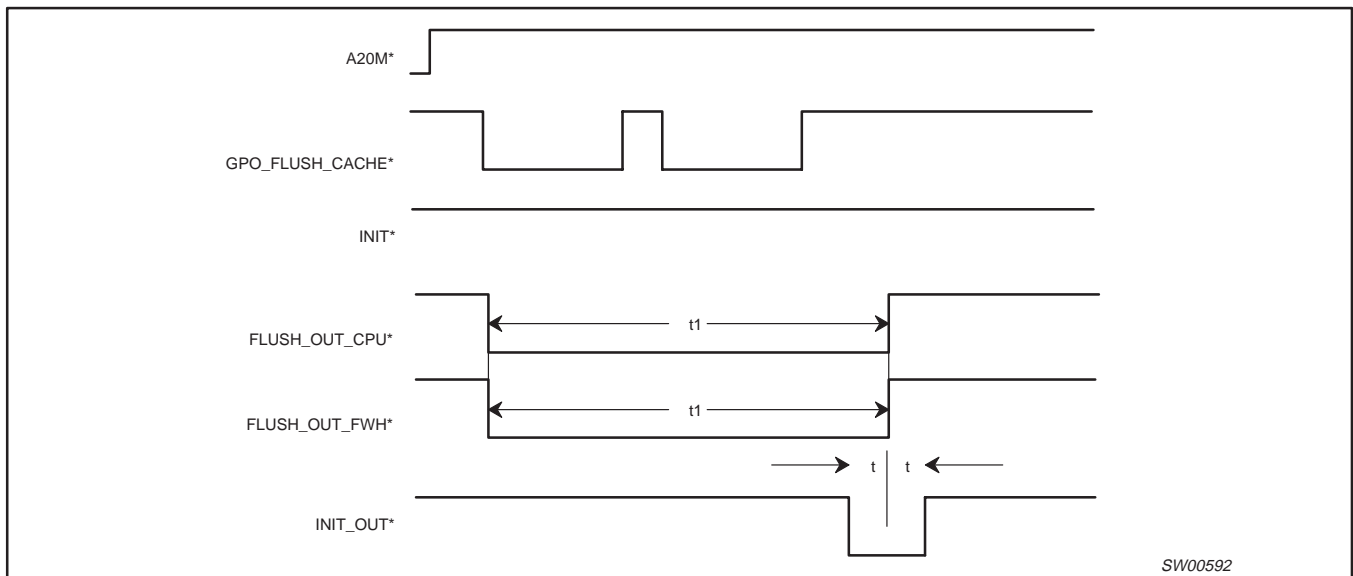

Figure 13. Waveforms for boundary GPO_FLUSH_CACHE* Case

- Timings should remain the same for both a 66 MHz or 33 MHz CLK_IN input.
- The boundary condition for INIT listed above, is a special case where immediately following the FLUSH_OUT*, INIT_OUT* cycle, the ICH2 asserts INIT* into the Glue Chip.
- The boundary condition for GPO_FLUSH_CACHE* listed above, is a special case where immediately following the first assertion of GPO_FLUSH_CACHE*, the GPO is de-asserted, then re-asserted again before the timings have had a chance to complete.

NOTE:

1. Nominal timing values with tolerances are listed in the DC Characteristics table.

GPO_FLUSH_CACHE* – input to logic, GPO from the ICH2, programmed active LOW.

INIT* – input to logic, INIT* signal from the ICH2.

A20M* – input to logic, A20M* signal from the ICH2.

FLUSH_OUT_CPU* – output of logic, route to CPU FLUSH* pin.

FLUSH_OUT_FWH* – output of logic, routed to FWH INIT* pin.

INIT_OUT* – output of logic, routed to CPU INIT* pin.

Glue chip 4

PCA9504A

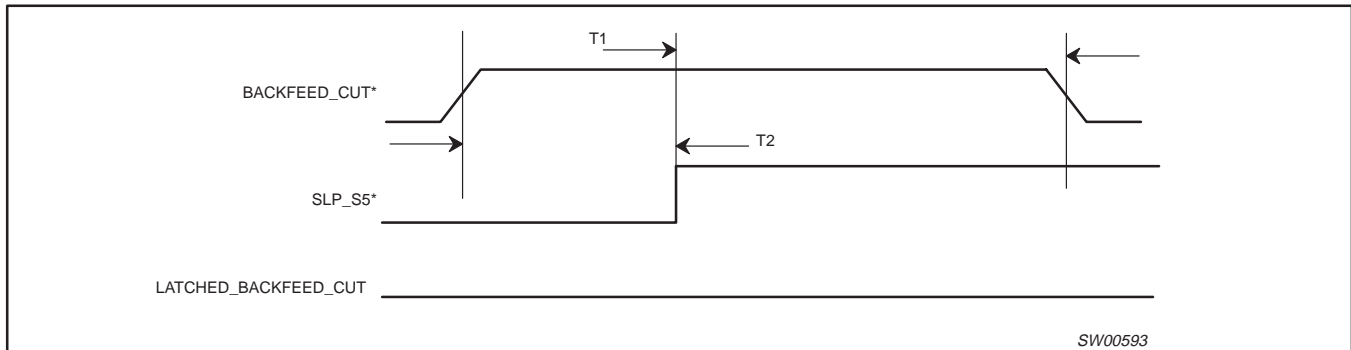

Figure 14. Power up signal sequencing

Power up signal sequencing is shown in Figure 14. BACKFEED_CUT* is following the power rail up to its final value. LATCHED_BACKFEED_CUT should stay LOW, never turning on. SLP_S5* goes to its HIGH value when the power rails have stabilized, ~25 msec after power on. BACKFEED_CUT* is pulled LOW a period T1 after SLP_S5* goes HIGH. T1 can be as short as 1msec. Typical measured values are ~200 msec. T1 and T2 are guaranteed by the inherent design of the system and are not controlled by Glue Chip.

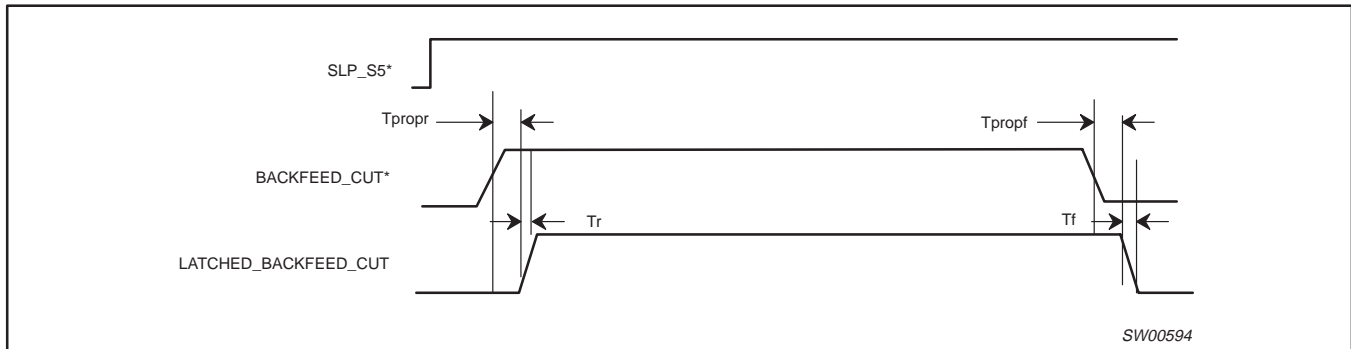

Figure 15. 1st sequence timing

The first possible sequence is with SLP_S5* staying HIGH and BACKFEED_CUT* transitioning from LOW to HIGH, remaining HIGH for an undetermined period and then going back to LOW and the system is back at the end of the power-up sequence. The power-up sequence is shown in Figure 15. During these BACKFEED_CUT* transitions, the propagation delays, rise and fall times, and going into regulation times LATCHED_BACKFEED_CUT are as described in Figure 16. The first sequence starts can start at the end of the power-up sequence at any time.

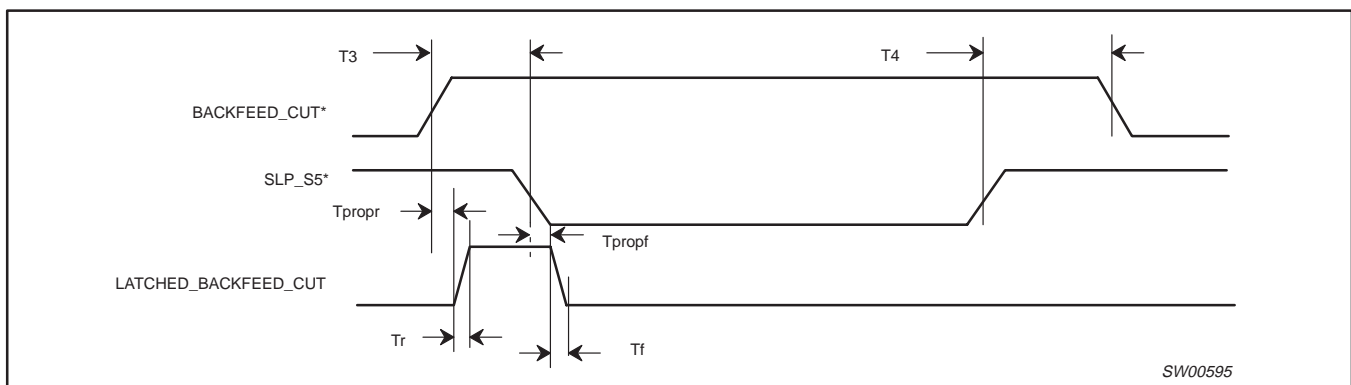

Figure 16. 2nd sequence timing

Signal sequencing for the second possible sequence is shown in Figure 16. BACKFEED_CUT* goes from LOW to HIGH and SLP_S5* goes from HIGH to LOW, 30 µsec to 65 µsec (T3) later. LATCHED_BACKFEED_CUT goes HIGH when BACKFEED_CUT* goes HIGH and then LATCHED_BACKFEED_CUT returns to LOW when SLP_S5* goes LOW. BACKFEED_CUT* stays HIGH and SLP_S5* stays LOW for an indeterminate time and then SLP_S5* will go HIGH. A minimum of 1msec (T4) later, BACKFEED_CUT* will go LOW and the system is back at the end of the power-up sequence. Typical measured values of T4 are ~250 msec. During all transitions, the propagation delays, rise and fall times, and going into regulation times for LATCHED_BACKFEED_CUT are as described in Figure 16. The first sequence starts can start at the end of the power-up sequence at any time.

Glue chip 4

PCA9504A

RSMRST* GENERATION

RSMRST* is a delayed 3.3 V hysteresis copy of V_5PO_STBY. RSMRST* is delayed going inactive from the rising edge of V_5PO_STBY by 32 ms, nominal. This delay starts when V_5PO_STBY hits the trip point. There is minimal delay on the falling edge.

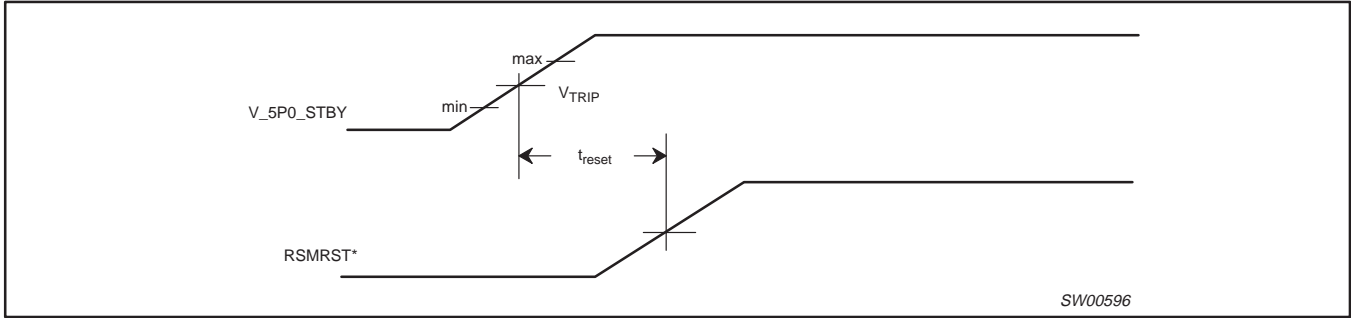

Figure 17. Resume reset functionality

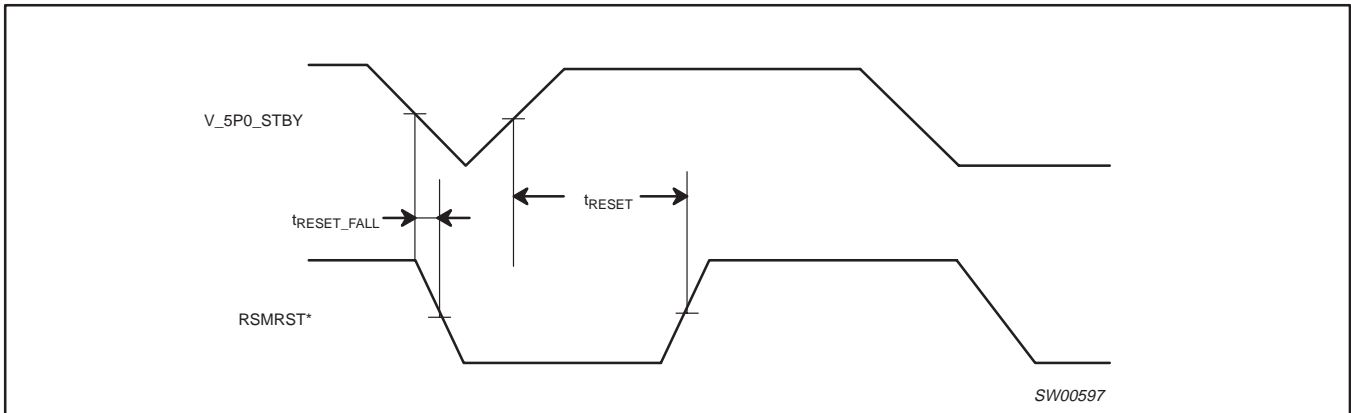

Figure 18. Resume reset functionality during brown out

Glue chip 4

PCA9504A

AUDIO-DISABLE

AUD_EN	PCIRST	AUD_RST
0	0	0
0	1	0
1	0	0
1	1	1

MUTE AUDIO CIRCUIT

MUTE_AUD	AUD_SHDN
0	1
1	0

HD SINGLE COLOR LED DRIVER

PRIMARY_HD	SECONDARY_HD	SCSI	HD_LED
0	0	0	0
0	X	X	0
X	0	X	0
X	X	0	0
1	1	1	HI-Z

IDE RESET SIGNAL GENERATION AND PCIRST DRIVE STRENGTH

PCIRST	IDE_RSTDRV ¹	PCIRST_OUT
0	0	0
1	1	1

NOTE:

1. IDE_RSTDRV is a 5 V copy of PCIRST. PCIRST_OUT is a 3.3 V copy of PCIRST.

PWRGD SIGNAL GENERATION

FPRST	PWRGD_PS	PWRGD_3V
0	0	0
0	1	0
1	0	0
1	1	1

FLUSH_OUT / INIT_OUT CIRCUIT

CASE	A20M	GPO_FLUSH_CACHE	INIT	FLUSH_OUT_CPU	FLUSH_OUT_FWH	INIT_OUT
1	1	Falling edge	0	0(for t1)	0(for t1)	0, Hi-Z, then 0 (delayed by t1-t, then active for 2*t)
2	1	Falling edge	1	0(for t1)	0(for t1)	Hi-Z, 0 (delayed by t1-t, then active for 2*t)
3	X	1	0	Hi-Z	Hi-Z	0
4	X	1	1	Hi-Z	Hi-Z	Hi-Z
5	0	Falling edge	1	Hi-Z	Hi-Z	Hi-Z
6	0	Falling edge	0	Hi-Z	Hi-Z	0

CLK_IN AND SEL_33_66

SEL_33_66	CLK_IN RATE
0	66 MHz
1	33 MHz

Glue chip 4

PCA9504A

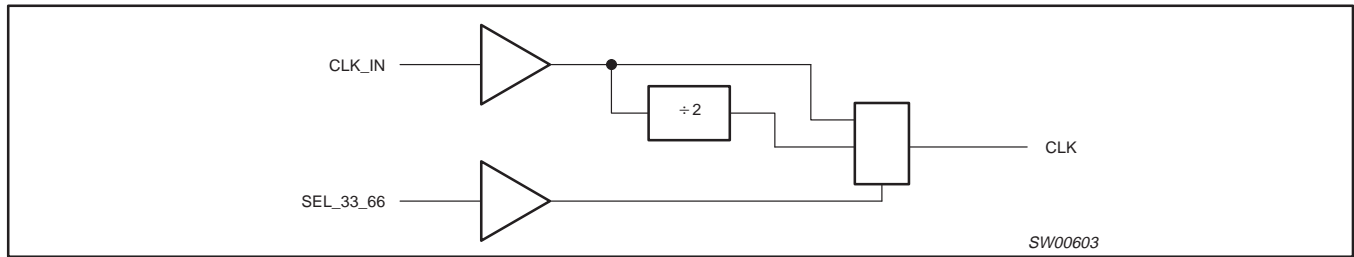

Figure 19.

GP_IN/GP_OUT GENERAL PURPOSE GATES

GP1_INA	GP1_INB	GP1_OUT
0	0	1
0	1	1
1	0	1
1	1	0

GP_IN/GP_OUT GENERAL PURPOSE GATES (continued)

GP2_IN	GP2_OUT
0	1
1	0

GP_IN/GP_OUT GENERAL PURPOSE GATES (continued)

GP3_IN	GP3_OUT
0	0
1	1

POWER SEQUENCING / BACKFEED_CUT

PWRGD_PS	SLP_S3	BACKFEED_CUT
0	0	HI-Z
0	1	HI-Z
1	0	HI-Z
1	1	0

POWER SUPPLY TURN-ON CIRCUIT

SLOT0CC	SLP_S3	SLP_S3A
0	0	Hi-Z
0	1	0
1	0	Hi-Z
1	1	Hi-Z

RAMBUS_SCK_BJT

PWRGD_3V	SCK_BJT_GATE
0	Hi-Z
1	0

Glue chip 4

PCA9504A

VGA DCC VOLTAGE TRANSLATION

3V_DDCSDA	3V_DDCSCL	5V_DDCSDA	5V_DDCSCL
0	0	0	0
0	1	0	1
1	0	1	0
1	1	1	1

HSYNC / VSYNC VOLTAGE TRANSLATION

HSYNC_3V	HSYNC_5V	VSYNC_3V	VSYNC_5V
0	0	0	0
1	1	1	1

POWER LED DRIVER

YLW_BLNK	SLP_S5	YLW_LED	GRN_BLNK	SLP_S5	GRN_LED
0	0	0	0	0	0
0	1	0	0	1	0
1	0	0	1	0	0
1	1	HI-Z	1	1	Hi-Z

Glue chip 4

PCA9504A

TSSOP56: plastic thin shrink small outline package; 56 leads; body width 6.1 mm

SOT364-1

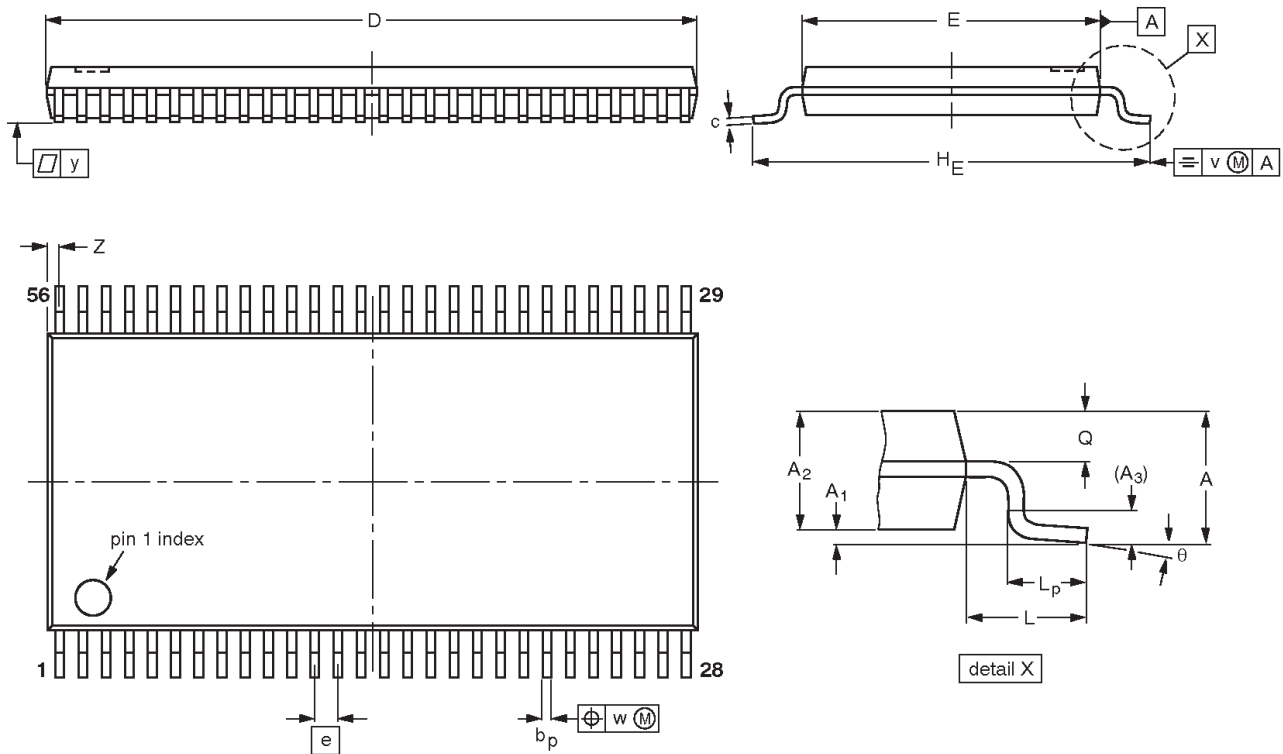

DIMENSIONS (mm are the original dimensions).

UNIT	A max.	A ₁	A ₂	A ₃	b _p	c	D ⁽¹⁾	E ⁽²⁾	e	H _E	L	L _p	Q	v	w	y	Z	θ
mm	1.2	0.15 0.05	1.05 0.85	0.25	0.28 0.17	0.2 0.1	14.1 13.9	6.2 6.0	0.5	8.3 7.9	1	0.8 0.4	0.50 0.35	0.25	0.08	0.1	0.5 0.1	8° 0°

Notes

1. Plastic or metal protrusions of 0.15 mm maximum per side are not included.
2. Plastic interlead protrusions of 0.25 mm maximum per side are not included.

OUTLINE VERSION	REFERENCES				EUROPEAN PROJECTION	ISSUE DATE
	IEC	JEDEC	JEITA			
SOT364-1		MO-153				-99-12-27 03-02-19

Glue chip 4

PCA9504A

REVISION HISTORY

Rev	Date	Description
_5	20040511	Product data (9397 750 13279). Supersedes data of 2003 Nov 10 (9397 750 12288). Modifications: <ul style="list-style-type: none">● Page 24, Audio-disable table: AUD_EN column (reading veritcally) changed from '0000' to '0011'.
_4	20031110	Product data (9397 750 12288); ECN 853-2206 30409 dated 10 October 2003. Supersedes data of 28 March 2003 (9397 750 09602).
_3	20030328	Product data (9397 750 09602); ECN: 853-2206 27930 (2003 Mar 28)

Glue chip 4

PCA9504A



Purchase of Philips I²C components conveys a license under the Philips' I²C patent to use the components in the I²C system provided the system conforms to the I²C specifications defined by Philips. This specification can be ordered using the code 9398 393 40011.

Data sheet status

Level	Data sheet status ^[1]	Product status ^[2] [3]	Definitions
I	Objective data	Development	This data sheet contains data from the objective specification for product development. Philips Semiconductors reserves the right to change the specification in any manner without notice.
II	Preliminary data	Qualification	This data sheet contains data from the preliminary specification. Supplementary data will be published at a later date. Philips Semiconductors reserves the right to change the specification without notice, in order to improve the design and supply the best possible product.
III	Product data	Production	This data sheet contains data from the product specification. Philips Semiconductors reserves the right to make changes at any time in order to improve the design, manufacturing and supply. Relevant changes will be communicated via a Customer Product/Process Change Notification (CPCN).

[1] Please consult the most recently issued data sheet before initiating or completing a design.

[2] The product status of the device(s) described in this data sheet may have changed since this data sheet was published. The latest information is available on the Internet at URL <http://www.semiconductors.philips.com>.

[3] For data sheets describing multiple type numbers, the highest-level product status determines the data sheet status.

Definitions

Short-form specification — The data in a short-form specification is extracted from a full data sheet with the same type number and title. For detailed information see the relevant data sheet or data handbook.

Limiting values definition — Limiting values given are in accordance with the Absolute Maximum Rating System (IEC 60134). Stress above one or more of the limiting values may cause permanent damage to the device. These are stress ratings only and operation of the device at these or at any other conditions above those given in the Characteristics sections of the specification is not implied. Exposure to limiting values for extended periods may affect device reliability.

Application information — Applications that are described herein for any of these products are for illustrative purposes only. Philips Semiconductors make no representation or warranty that such applications will be suitable for the specified use without further testing or modification.

Disclaimers

Life support — These products are not designed for use in life support appliances, devices, or systems where malfunction of these products can reasonably be expected to result in personal injury. Philips Semiconductors customers using or selling these products for use in such applications do so at their own risk and agree to fully indemnify Philips Semiconductors for any damages resulting from such application.

Right to make changes — Philips Semiconductors reserves the right to make changes in the products—including circuits, standard cells, and/or software—described or contained herein in order to improve design and/or performance. When the product is in full production (status 'Production'), relevant changes will be communicated via a Customer Product/Process Change Notification (CPCN). Philips Semiconductors assumes no responsibility or liability for the use of any of these products, conveys no license or title under any patent, copyright, or mask work right to these products, and makes no representations or warranties that these products are free from patent, copyright, or mask work right infringement, unless otherwise specified.

Contact information

For additional information please visit
<http://www.semiconductors.philips.com>. Fax: +31 40 27 24825

© Koninklijke Philips Electronics N.V. 2004
 All rights reserved. Printed in U.S.A.

Date of release: 05-04

For sales offices addresses send e-mail to:
sales.addresses@www.semiconductors.philips.com

Document order number:

9397 750 13279

Let's make things better.

Looking for pricing, stock, or lifecycle information?

Click below to explore more details on WIN SOURCE:

 [View PCA9504ADGG,112 on WIN SOURCE](#)

 [NXP / Nexperia Information](#)

Optimize Your Supply Chain with WIN SOURCE Solutions

-  Global Sourcing Solution
-  Obsolete Management
-  Cost Control Management
-  Shortage Management
-  Alternative Solution
-  Excess Inventory Management