



**THE DATASHEET OF
PCA8802CX8/B/1**





PCA8802

Smartcard RTC; ultra low power oscillator with integrated counter for initiating one time password generation

Rev. 6 — 1 July 2014

Product data sheet

1. General description

The PCA8802 is a CMOS integrated circuit for battery operation, typically supplied by button cells or flexible polymer batteries. Incorporated is a 32.768 kHz quartz crystal oscillator circuit including the two load capacitors. The circuit is optimized for a quartz with 6 pF load capacitance specification. Higher values can also be used with the addition of external load capacitors.

The main function of the oscillator is to generate a $\frac{1}{32}$ Hz clock signal which is used to increment a 24 bit binary counter. The counter can be read over the serial interface and can also be set to any desired value. Control over the divider chain also allows for accurate starting of the counter. Incrementing of the counter value during read is prevented by freezing of the counter during access.

An interrupt signal is also available and is triggered coincident with the counter updating. This signal can be used as a wake-up for a microcontroller.

2. Features and benefits

- 32.768 kHz quartz oscillator, amplitude regulated with excellent frequency stability and high immunity to leakage currents
- Two integrated quartz crystal oscillator capacitors
- Very low current consumption: typically 130 nA
- Two-wire serial interface (I²C-bus)
- Integrated 24-bit counter with auto increment every 32 seconds
- Interrupt output for processor wake-up
- Stop function for accurate time setting and current saving during shelf life
- User test modes for accelerated application testing and development

3. Applications

- One time password function generators
- Ultra low-power time keeper circuit



4. Ordering information

Table 1. Ordering information

Type number	Package		
	Name	Description	Version
PCA8802CX8	WLCSP8	wafer level chip-size package; 8 bumps	PCA8802CX
PCA8802U	WLCSP8	wafer level chip-size package; 8 bumps	PCA8802U

4.1 Ordering options

Table 2. Ordering options

Product type number	Orderable part number	Sales item (12NC)	Delivery form	IC revision
PCA8802CX8/B/1	PCA8802CX8/B/1,027	935288465027	solder bumps; chips in tape and reel	1
PCA8802U/12AA/1 ^[1]	PCA8802U/12AA/1,00	935297673005	gold bumps; sawn wafer on Film Frame Carrier (FFC)	1
PCA8802U/2AA/1 ^[1]	PCA8802U/2AA/1,026	935288535026	gold bumps; chips in tray	1
PCA8802UG/12KB/1 ^[1]	PCA8802UG/12KB/1,0	935299008005	gold bumps; sawn wafer on Film Frame Carrier (FFC)	1

[1] Bump hardness see [Table 18](#).

Table 3. PCA8802 wafer information

Product type number	Wafer thickness	Wafer diameter	FFC for wafer size	Marking of bad die
PCA8802U/12AA/1	200 µm	6 inch	8 inch	wafer mapping
PCA8802UG/12KB/1	250 µm	6 inch	8 inch	inking and wafer mapping

For packing information, see [Section 17 "Packing information" on page 28](#).

5. Marking

Table 4. Marking codes

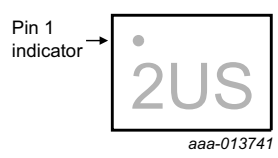
Product type number	Marking code
PCA8802CX8/B/1	PC8802-1 backside (non-active side) laser marking 
PCA8802U/12AA/1	PC8802-1
PCA8802U/2AA/1	PC8802-1
PCA8802UG/12KB/1	PC8802-1

6. Block diagram

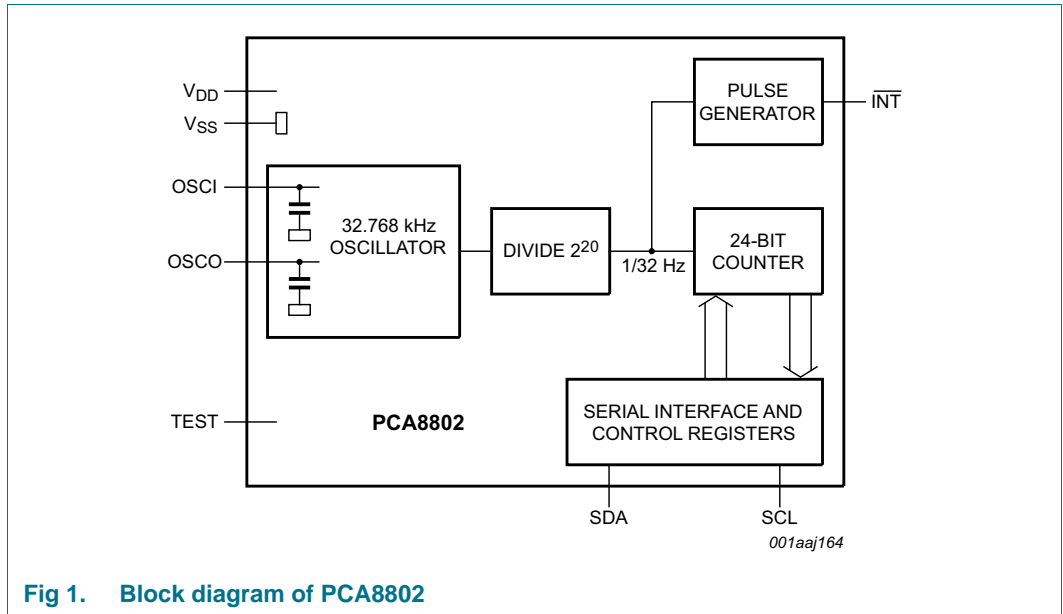
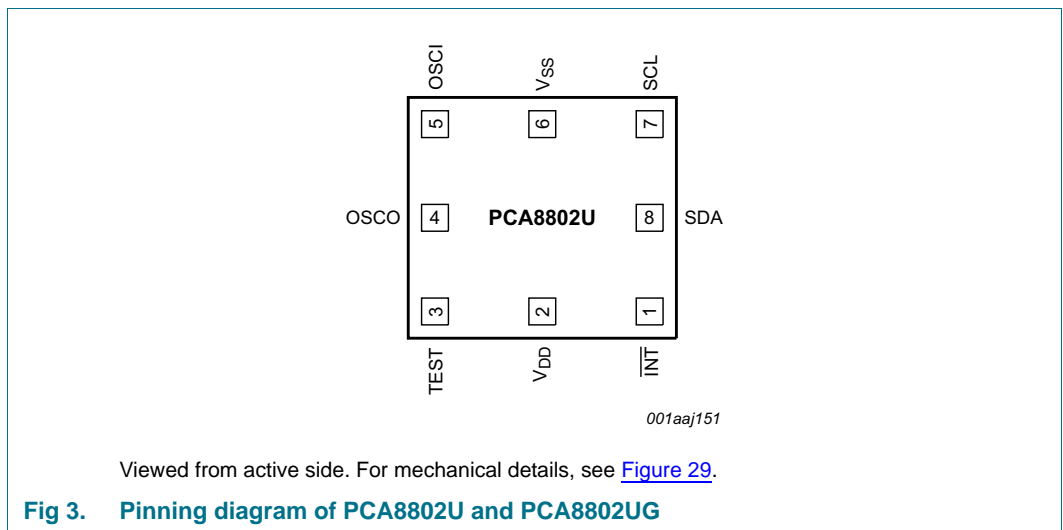
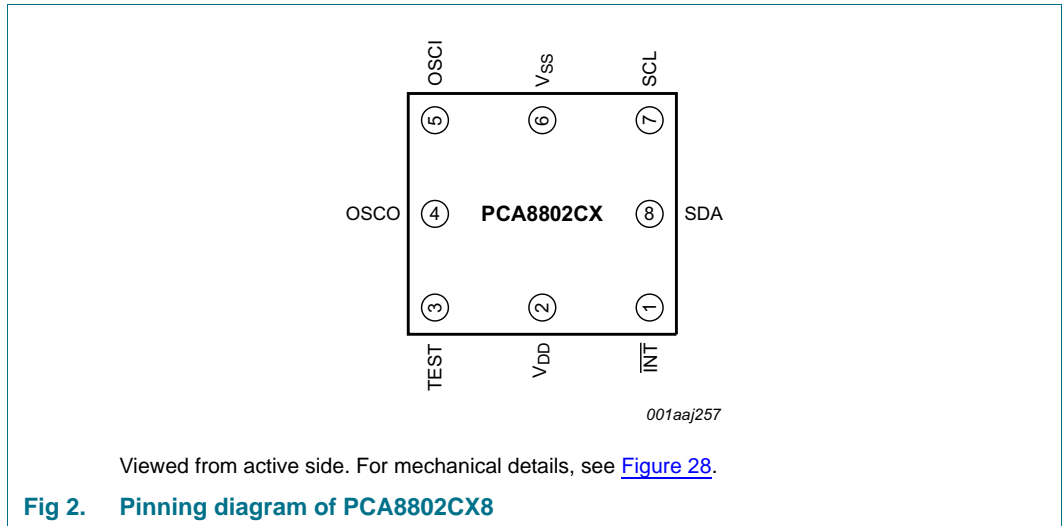

Fig 1. Block diagram of PCA8802

7. Pinning information

7.1 Pinning



7.2 Pin description

Table 5. Pin description for PCA8802

Input or input/output pins must always be at a defined level (V_{SS} or V_{DD}) unless otherwise specified.

Symbol	Pin	Description
\overline{INT}	1	interrupt and test mode output, push-pull
V_{DD}	2	supply voltage
TEST	3	test pin; must be connected to V_{SS}
OSCO	4	oscillator output
OSCI	5	oscillator input
V_{SS}	6	ground
SCL	7	serial interface, clock
SDA	8	serial interface, bidirectional data line; push-pull

8. Device protection diagram

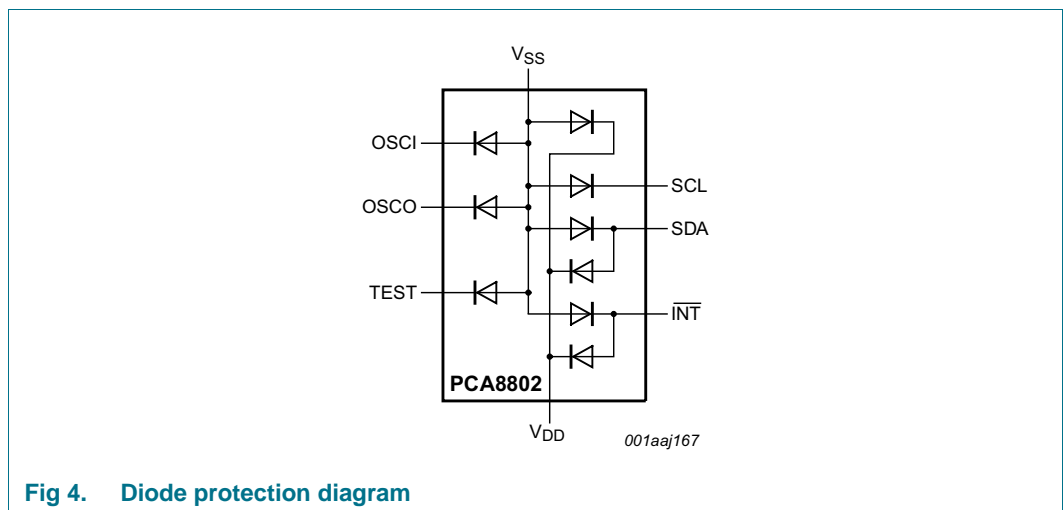

Fig 4. Diode protection diagram

9. Functional description

The PCA8802 is an ultra low-power device for battery operations. The integrated oscillator circuit generates a $\frac{1}{32}$ Hz clock signal to increment a 24-bit counter. The communication between the PCA8802 and other devices is made via point to point I²C-bus protocol.

The device is always running but for longer storage time it can be put in deep sleep and enabled again in case of delivery.

The functions of the device can be controlled with the following instruction set:

Table 6. Instruction set overview

Instruction	Description	Reference
wrt_cmd	device write access	Section 9.6.2
dvs_cmd	divider start or stop switch	Section 9.6.3
pwd_cmd	deep sleep mode switch	Section 9.6.4
32k_cmd	32.768 kHz clock signal on the pin $\overline{\text{INT}}$ switch	Section 9.6.5
fst_cmd	fast system development mode switch	Section 9.6.6
set_cmd	set counter instruction	Section 9.6.7
rd_cmd	counter read instruction	Section 9.6.8

9.1 Oscillator

The 32.768 kHz oscillator includes two integrated load capacitors and an automatic gain control to ensure a reliable start-up.

For prototype development and system debugging, it is possible to output a 32.768 kHz square wave on the INT pin with the 32k_cmd instruction.

9.1.1 Low-power operation

When the oscillator is running, a prime consideration for low power consumption is the series resistance R_s of the quartz used. The series resistance acts as a loss element. Low R_s reduces current consumption further.

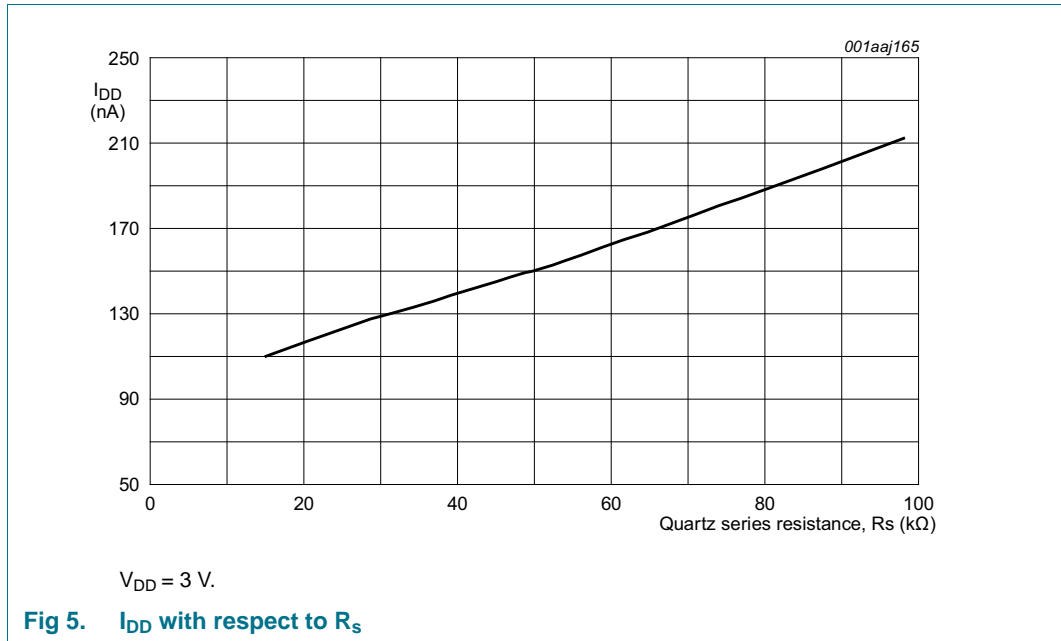

9.1.2 Deep sleep mode

With the deep sleep mode instruction (pww_cmd) the oscillator can be stopped and the device can be put into a deep sleep where power consumption is reduced to an absolute minimum. An example sequence can be found in [Table 9](#). In deep sleep mode, the interface is still accessible.

9.2 Divider

The divider chain is responsible for reducing the 32.768 kHz oscillator frequency down to $\frac{1}{32}$ Hz.

The dividers (see [Figure 6](#)) divider_2 and divider_3 can be reset with the dvs_cmd instruction. The 24-bit counter can be set when the dividers are held in reset, but this is not a requirement. This allows for accurate setting and restarting of the counter.

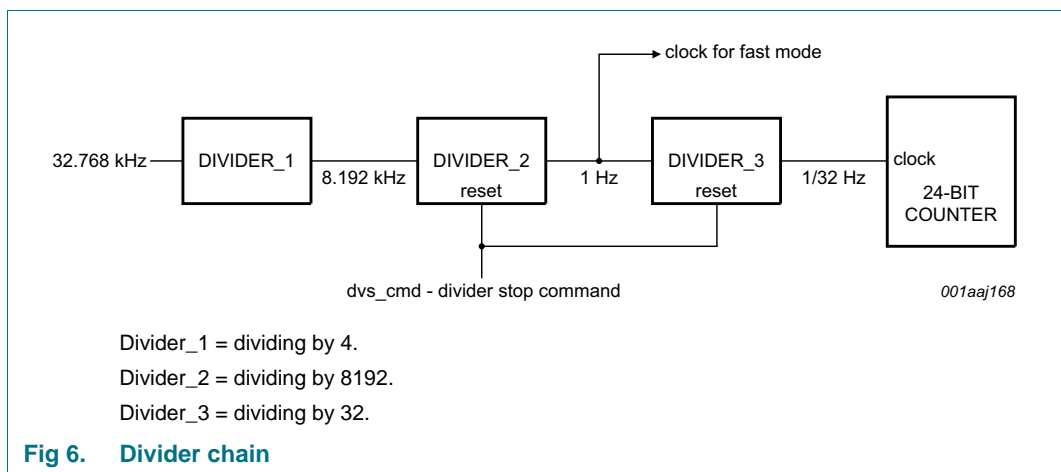

The interface is asynchronous to the quartz oscillator and the state of divider_1 cannot be known when the dvs_cmd is enabled. The 8.192 kHz clock could have just occurred and hence a delay of $\frac{1}{8192}$ seconds will occur before the next increment of the divider_2, or the 8.192 kHz clock could be just about to occur and immediately increment the divider_2.

As a consequence, an uncertainty of between zero and one 8192 Hz clock period (that is, a time uncertainty of about 0 s to 122 μ s) will be present when restarting the counter.

9.3 Binary counter

A 24-bit binary roll-over counter is implemented. The counter is reset at power-on.

The counter can be set to any value using the set_cmd instruction. The set_cmd instruction allows partial writing of data. Partial writing of the data parameters results in partial setting of the counter. For example, if data transfer is stopped after P1[23:16] (see Table 7) is transmitted, then only bit 23 to bit 16 will be updated. The counter will not increment while being set.

The counter can be halted by stopping the dividers using the dvs_cmd instruction.

The counter can be read at any time and the counter value remains stable during reading. If the counter is due to increment during the read or write cycle, then the request to increment will be held off until after the read has concluded. For this reason, it is important to read the counter in bursts, ensuring that an interface STOP condition (see Section 9.5.4) is present between read accesses. Reading for periods of more than 32 seconds at a time results in loss of counts.

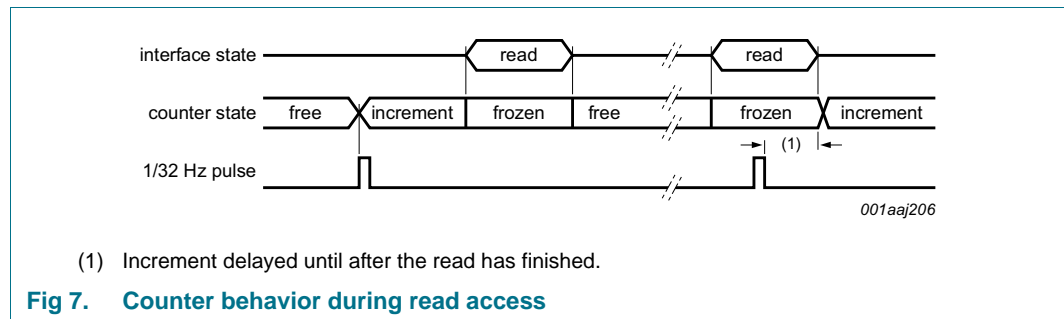

9.4 Pulse generator

An interrupt pulse is available at the $\overline{\text{INT}}$ pin. This pulse is generated once every 32 seconds. It could be used to wake up a microcontroller to perform a periodic function, for example, to calculate and update an LCD display with a new one-time password.

A pulse is generated coincident with the increment of the counter. The new counter value is immediately available.

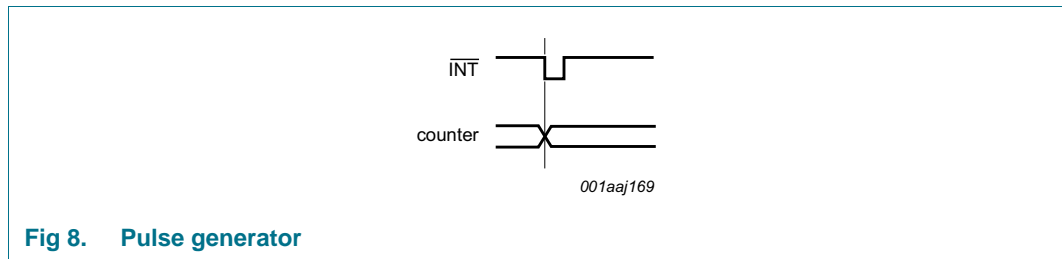

Fig 8. Pulse generator

9.5 I²C-bus interface

For a more detailed information about the I²C-interface, see [Ref. 10 "UM10204"](#)

9.5.1 Interface protocol

The serial interface is a point-to-point I²C-bus protocol. The I²C-bus protocol has the advantage of being robust in terms of immunity to electrical noise. Although the PCA8802 does not have the signal filters inside the interface pins, the slave address and acknowledge hand shaking is nevertheless implemented.

For power saving, the SDA output is a push-pull instead of the more traditional open-drain output. Push-pull prevents the need for power consuming pull-up resistors, but requires that the SDA line of the microcontroller is a push-pull as well¹ and does limit the operation to point-to-point only.

The following slave addresses plus a write and read bit are reserved for the PCA8802:

- write: 1010 0000
- read: 1010 0001

An incorrect slave address results in the device ignoring all bus data. A STOP or START condition (see [Section 9.5.4](#)) is required before a new transfer can be made.

9.5.1.1 The writing protocol

The writing protocol is shown in [Figure 9](#).

There is no restriction for the order of sending instructions. As many instructions as needed can be sent in one access. The total duration of one access must not exceed 32 seconds (see [Figure 11](#)).

1. If the SDA line on the microcontroller is open drain a pull-up resistor is needed.

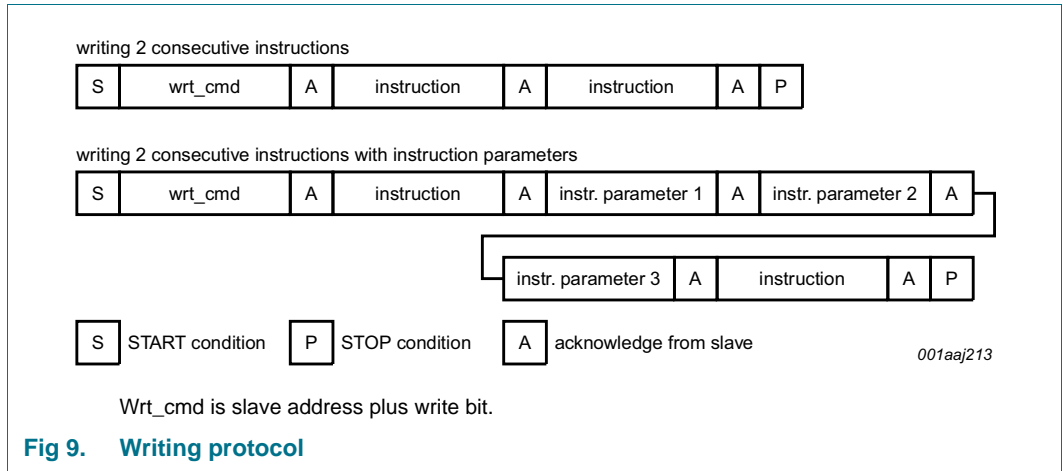

9.5.1.2 The reading protocol

The reading protocol is shown in [Figure 10](#).

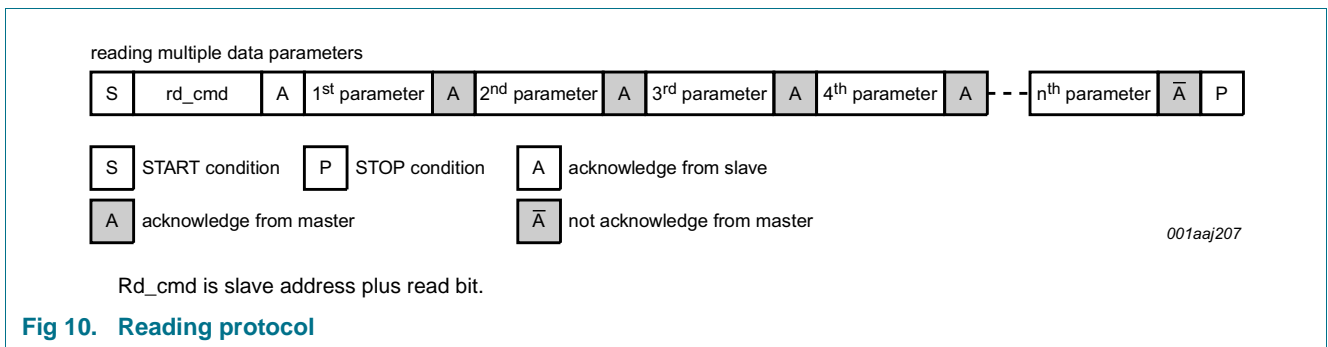

9.5.1.3 Reading and writing limitations

As the counter is frozen during interface accesses, all accesses must be completed within 32 seconds (see [Figure 11](#)). If this rule is not adhered to, then counts are dropped.

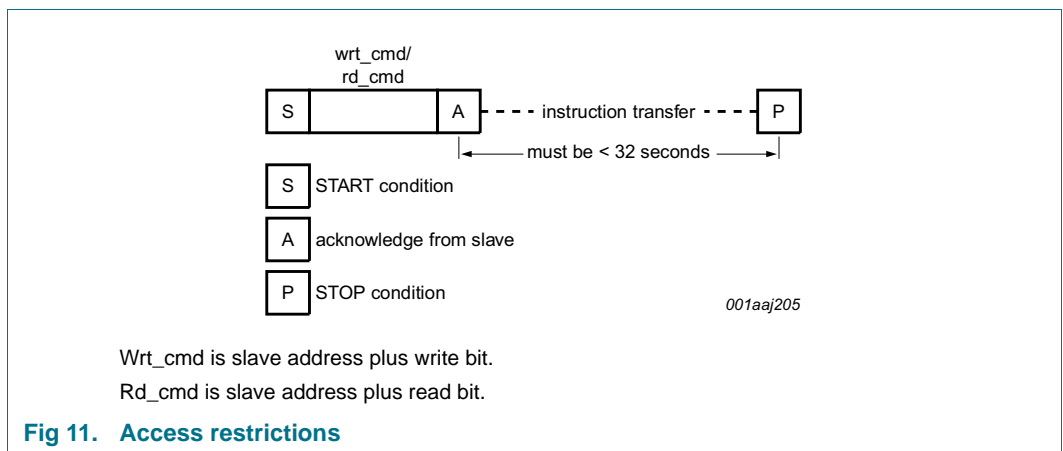

9.5.2 Bit transfer

One data bit is transferred during each clock pulse. The data on the SDA line must remain stable during the HIGH period of the clock pulse as changes in the data line at this time are interpreted as a control signal. Bit transfer is shown in [Figure 12](#).

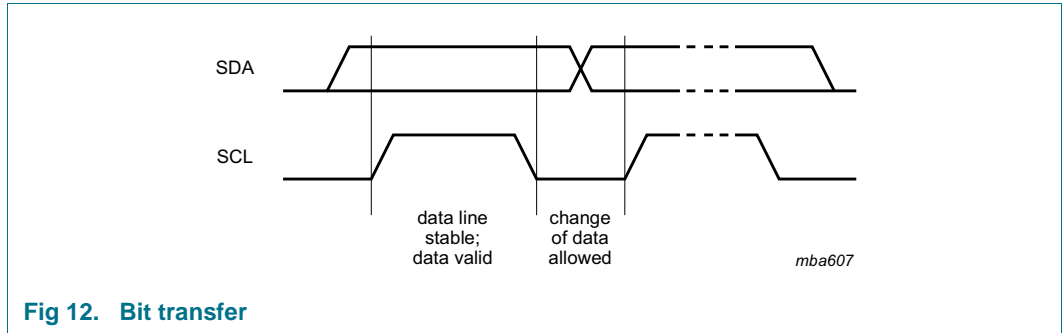

Fig 12. Bit transfer

9.5.3 Bit order

Data is transferred MSB first.

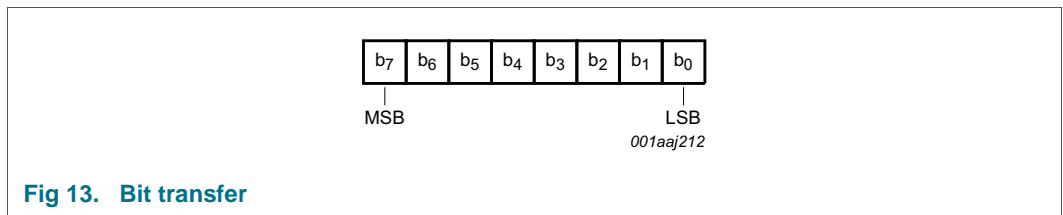

Fig 13. Bit transfer

9.5.4 START and STOP conditions

Both data and clock lines remain HIGH when the bus is not busy. A HIGH-to-LOW transition of the data line, while the clock is HIGH is defined as the START condition (S). A LOW-to-HIGH transition of the data line while the clock is HIGH is defined as the STOP condition (P). The START and STOP conditions are shown in [Figure 14](#).

The data on SDA is sampled with the rising edge of SCL. Data is output to SDA on the falling edge of SCL.

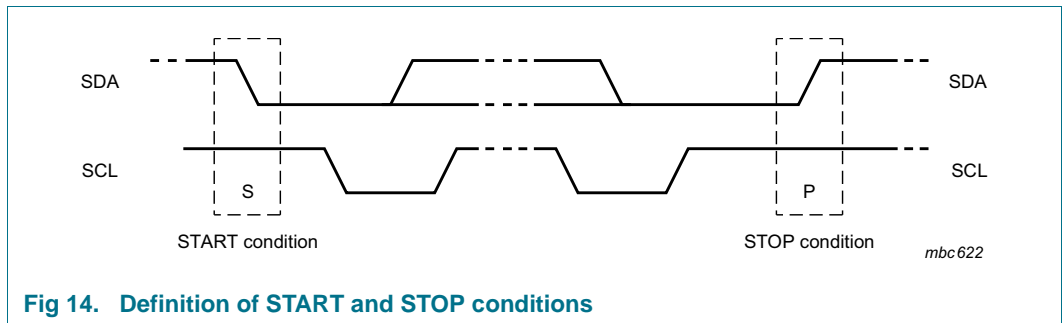

Fig 14. Definition of START and STOP conditions

9.5.5 System configuration

A device generating a message is a transmitter, a device receiving a message is the receiver. The device that controls the message is the master and the device which is controlled by the master is the slave.

9.5.6 Acknowledge

The number of data bytes transferred between the START and STOP conditions from transmitter to receiver is unlimited. But the duration of the access must not exceed 32 seconds. Each byte of 8 bits is followed by an acknowledge bit. The acknowledge bit is a HIGH level signal put on the bus by the transmitter during which time the master generates an extra acknowledge related clock pulse. A slave receiver which is addressed must generate an acknowledge after the reception of each byte. Also a master receiver must generate an acknowledge after the reception of each byte that has been clocked out of the slave transmitter. The device that acknowledges must pull-down the SDA line during the acknowledge clock pulse, so that the SDA line is stable LOW during the HIGH period of the acknowledge related clock pulse (set-up and hold times must be considered). A master receiver must signal an end of data to the transmitter by not generating an acknowledge on the last byte that has been clocked out of the slave. In this event, the transmitter must leave the data line HIGH to enable the master to generate a STOP condition. Acknowledgement is shown in [Figure 15](#).

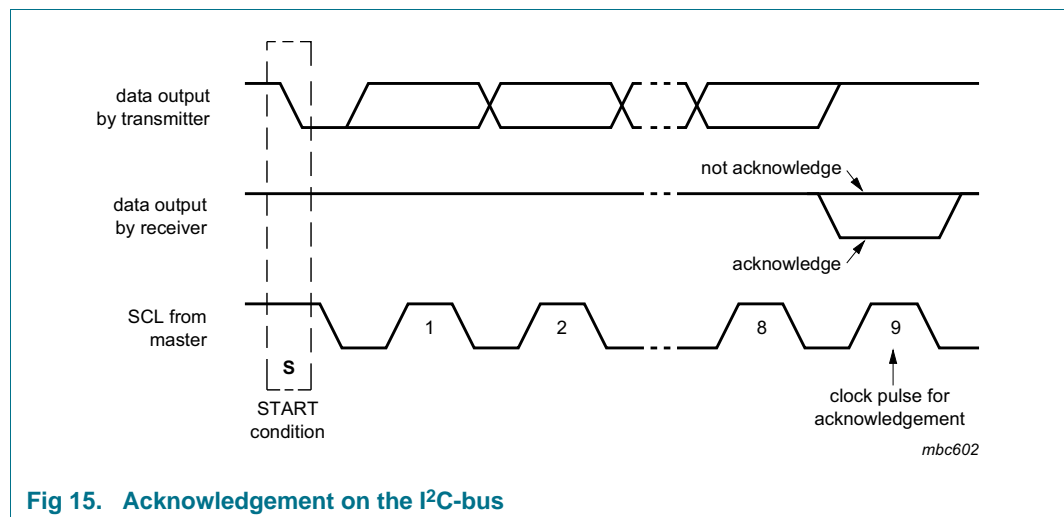

Fig 15. Acknowledgement on the I²C-bus

9.5.7 Data transfer

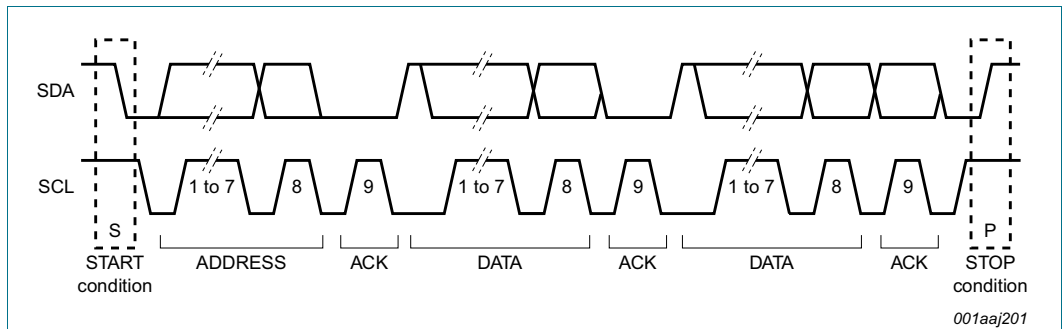

Fig 16. A complete data transfer

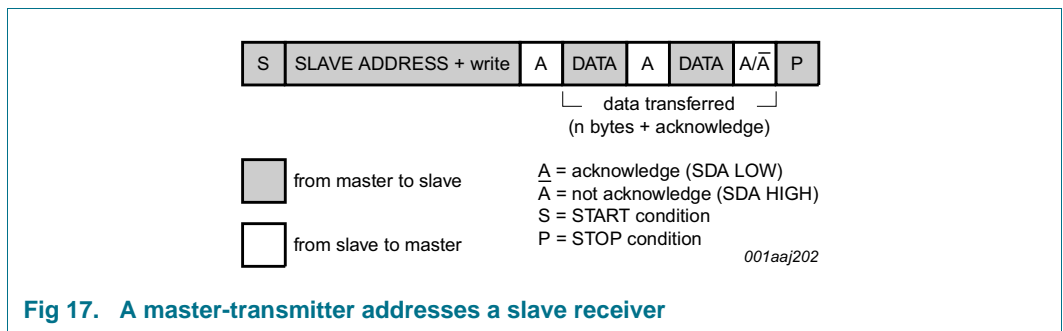

Fig 17. A master-transmitter addresses a slave receiver

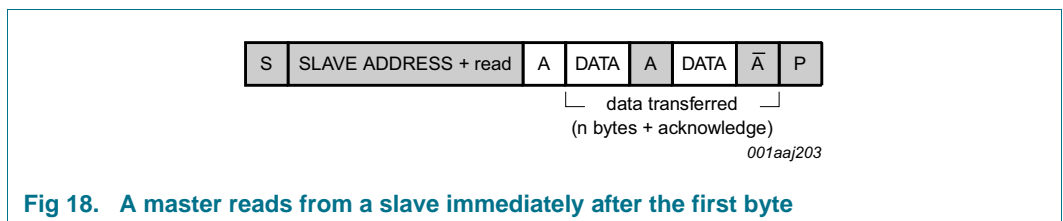
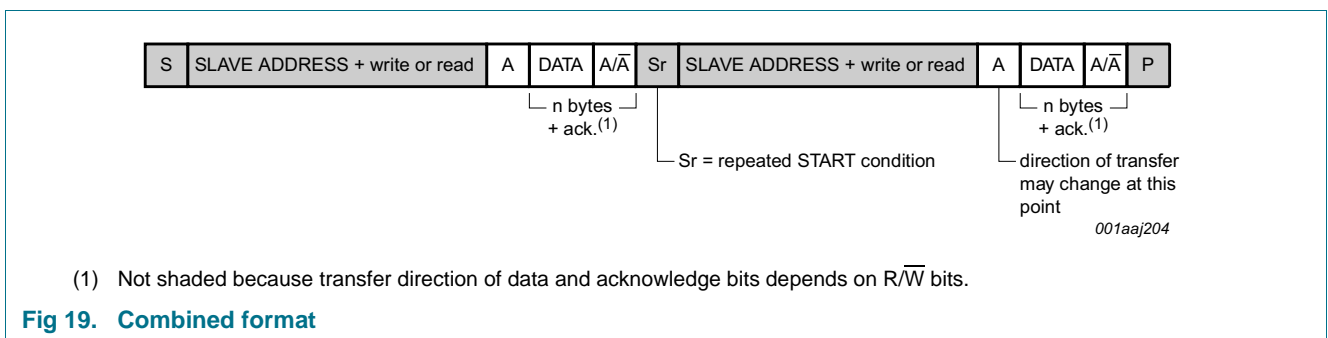

Fig 18. A master reads from a slave immediately after the first byte



(1) Not shaded because transfer direction of data and acknowledge bits depends on R/W bits.

Fig 19. Combined format

9.5.7.1 Example data transfers

Example 1: Sending the instruction dvs_cmd followed by fst_cmd is shown in Figure 20.

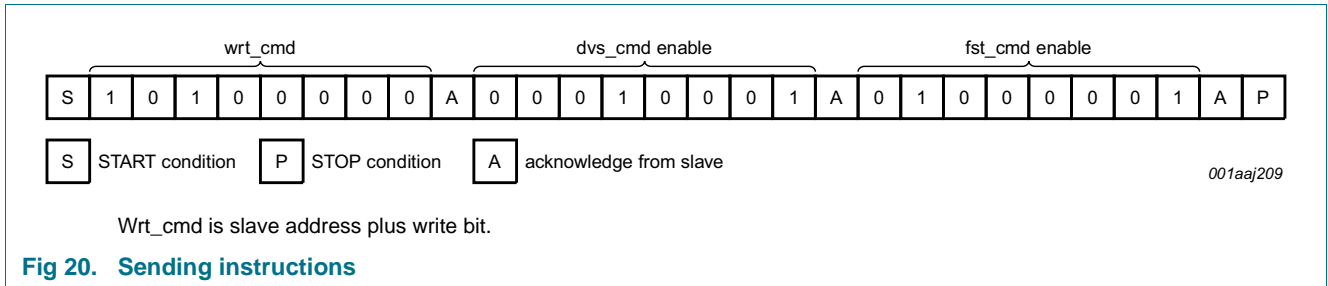

Example 2: Sending dvs_cmd followed by setting the counter to A90001h is shown in Figure 21

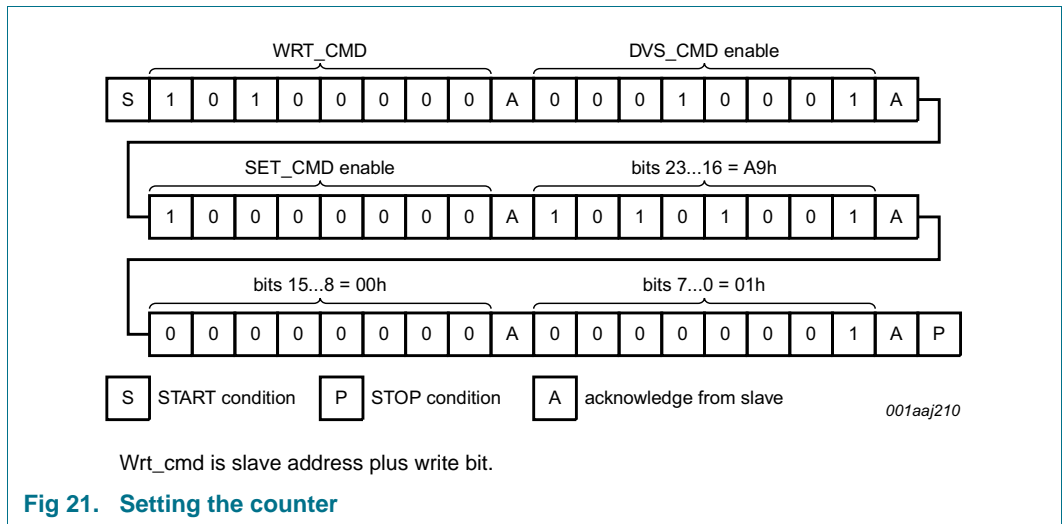

Example 3: Reading the counter (counter = 000011h) is shown in Figure 22.

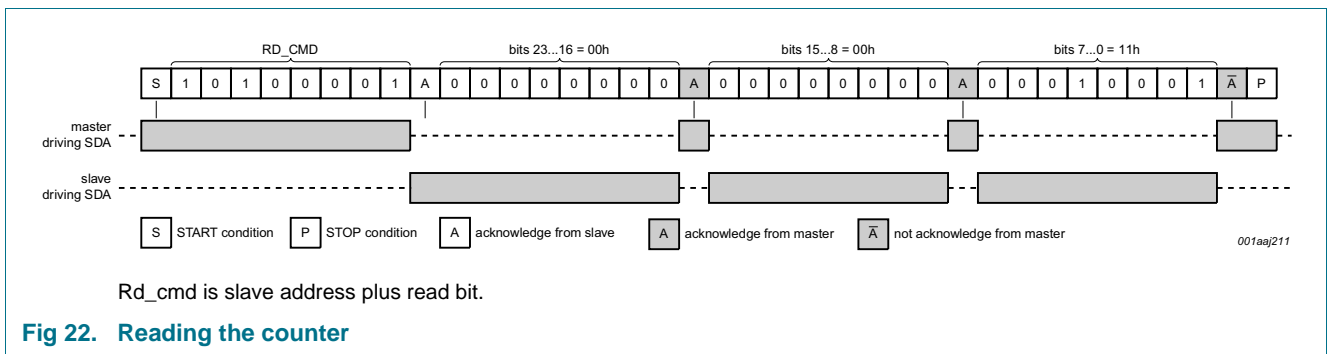

9.6 Instructions

9.6.1 Instruction set

Table 7. Write instructions

The writing protocol is illustrated in [Figure 9](#).

First byte		Second byte		Further bytes	Action
Instruction	Instruction code	Instruction	Instruction code	Parameters	
wrt_cmd	1010 0000			-	device slave write address: slave address plus write bit
		dvs_cmd	0001 0001	-	stop and reset dividers
			0001 0000	-	start dividers
		pwd_cmd	0010 0001	-	shut down the device
			0010 0000	-	enable the device
		32k_cmd	0011 0001	-	enable output of 32.768 kHz on pin $\overline{\text{INT}}$
			0011 0000	-	disable output of 32.768 kHz on pin $\overline{\text{INT}}$
		fst_cmd	0100 0001	-	fast mode; increments counter every second
			0100 0000	-	fast mode disable
		set_cmd	1000 0000		
P1[23:16]					parameter with counter values
P2[15:8]					
P3[7:0]					

Table 8. Read instructions

The reading protocol is illustrated in [Figure 10](#).

First byte		Further bytes	Action
Instruction	Instruction code	Parameters	
rd_cmd ^[1]	1010 0001		device slave read address: slave address plus read bit
		P1[23:16]	parameter with counter values; continues to read until no ACK is received; counter is not updated during this time
		P2[15:8]	
		P3[7:0]	
		P4[23:16]	
:			

[1] Read of the counter is implicit with an interface read.

9.6.2 Instruction wrt_cmd

The write instruction (wrt_cmd) precedes each write sequence. Details of the writing protocol can be found in [Section 9.5.1.1](#).

9.6.3 Instruction dvs_cmd

The divider stop instruction (dvs_cmd) can be used to freeze the divider chain and to put it in a defined state. The first 2 bits of the divider chain cannot be influenced. With this instruction, it is possible to control the time to the next increment of the counter. See [Table 10](#).

When the dividers are restarted, the first increment of the 24-bit counter will be after 32 seconds.

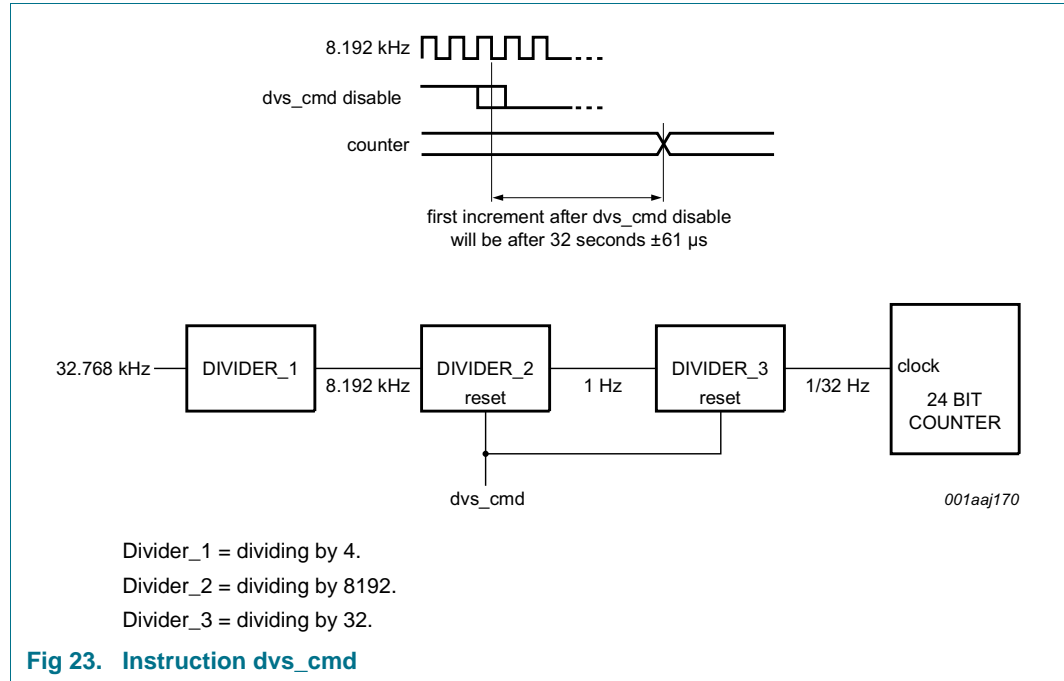

When the dividers are restarted, the 8192 Hz clock could have just occurred and hence a delay of $\frac{1}{8192}$ seconds will occur before the next increment of the divider_2. Or the 8192 Hz clock could be just about to occur and immediately increment the divider_2. As a consequence, an uncertainty of one half clock period in the starting of the 24 bit counter is present when restarting (see [Figure 23](#)).

9.6.4 Instruction pwd_cmd

The power down instruction (pwd_cmd) is intended to be used to put the system into a low-power mode for storage. Static leakage current will be the only power consumed. Storage at temperatures exceeding room temperature can increase leakage currents.

Entering deep sleep mode requires a specific sequence of events since under normal circumstances stopping the oscillator would result in a chip reset.

Table 9. Deep sleep mode sequence

Step	Action	Code sequence	Note
To enter deep sleep mode			
1	initiate transfer	START condition	-
2	send wrt_cmd	1010 0000	-
3	enable dvs_cmd	0001 0001	stop the divider
4	set counter with set_cmd	1000 0000	set the counter = AAAAAAh
		1010 1010	P1[23:16]
		1010 1010	P2[15:8]
		1010 1010	P3[7:0]
5	enable pwd_cmd	0010 0001	stop the oscillator
6	end transfer	STOP condition	-
7	device is now in deep sleep mode	-	-
To exit deep sleep mode			
1	initiate transfer	START condition	-
2	send wrt_cmd	1010 0000	-
3	disable pwd_cmd	0010 0000	oscillator starts on the ACK cycle of this instruction
4	disable dvs_cmd	0001 0000	enable the divider again
5	end transfer	STOP condition	-

9.6.5 Instruction 32k_cmd

The 32.768 kHz enable instruction (32k_cmd) is intended to aid with oscillator characterization during system development. With this instruction, it is possible to obtain a 32.768 kHz clock on the INT pin which can be used for measurement.

This mode does not affect other operation of the chip except for the loss of interrupt output.

9.6.6 Instruction fst_cmd

The fast mode instruction (fst_cmd) is intended to enable faster system development. When enabled, the counter increments once every second instead of once every 32 seconds. Interrupt pulses are generated once every second as well.

When using fst_cmd, data access to the device must be completed within 1 second, if not then counter increments are lost. The 1 second period is measured from the ACK cycle of a valid slave address to the next STOP or repeated START. A repeated START is sufficient to allow the counter to increment.

9.6.7 Instruction set_cmd

The counter can be set to any value using the set instruction (set_cmd). Partial writing of the data parameters results in partial setting of the counter. For example, if data transfer is stopped after P1[23:16] is transmitted, then only bit 23 to bit 16 will be updated.

This instruction takes only 3 parameters in one command. Data after the third parameter are interpreted as the next instruction.

Accurate setting and start-up can be implemented using the `dvs_cmd` instruction in cooperation with the `set_cmd` instruction. An example is shown in [Table 10](#).

Table 10. Example of accurate setting of the counter

Step	Action	Code sequence	Note
1	initiate transfer	START condition	-
2	send <code>wrt_cmd</code>	1010 0000	-
3	enable <code>dvs_cmd</code>	0001 0001	-
4	set counter with <code>set_cmd</code>	1000 0000	set the counter = 1
		0000 0000	P1[23:16]
		0000 0000	P2[15:8]
		0000 0001	P3[7:0]
5	end transfer	STOP condition	-
6	wait for an external time marker	-	-
7	initiate transfer	START condition	-
8	send <code>wrt_cmd</code>	1010 0000	-
9	disable <code>dvs_cmd</code>	0001 0000	counter starts on the ACK cycle of this instruction
10	end transfer	STOP condition	-

9.6.8 Instruction `rd_cmd`

With the read instruction (`rd_cmd`) the counter value can be read at any time. When the counter value is read, the counter is frozen so that there are no changes during the read back. After a read is terminated, the counter will be allowed to increment again. Any increment that was scheduled during the frozen period will then be effected.

Reading the counter is cyclic, that is, the device repeatedly returns the present counter value until the read is terminated. Reading the counter more than once can be useful in the case that the application is subject to a strong Electromagnetic Interference (EMI) environment, so that read-back values can be compared.

Read back must be terminated within 32 seconds else a count will be dropped.

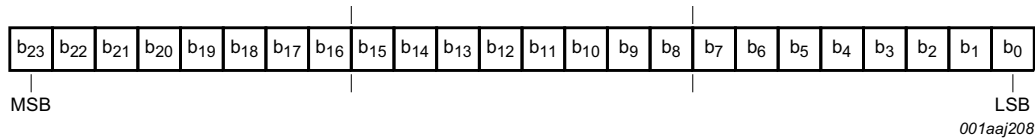

Fig 24. Read bit order

9.7 Power-on reset

At initial power-on a reset is generated. The reset lasts not longer than 10 ms. During this time, the serial interface will not respond when accessed. The state of the device after power-on reset is shown in [Table 11](#).

Table 11. Reset state

Instruction name	State after reset
dvs_cmd	disabled
pwd_cmd	disabled
32k_cmd	disabled
fst_cmd	disabled
24-bit counter	000000h

10. Application design-in information

10.1 PCB or foil landing site

The layout of the landing sites is important. It is recommended to follow the following guidelines

1. All landing sites should be the same size. When one site has a different size or shape, e.g. to indicate pad one, then the pull on the die produced by the surface tension of the solder will be different in one place. This variation can lead to the die not laying flat on the Printed-Circuit Board (PCB) or foil. This can also result in weak solder joints for some pins.
2. It is recommended to use circular landing sites of the same diameter as the solder ball. This will help with self alignment. Solder bump dimensions can be found in [Figure 28](#).
3. If no solder resist is used on the PCB or foil, then consideration should be given to the amount of run-off of the solder along the track connected to the landing site. Uneven run-off may result in similar problems as described in 1.

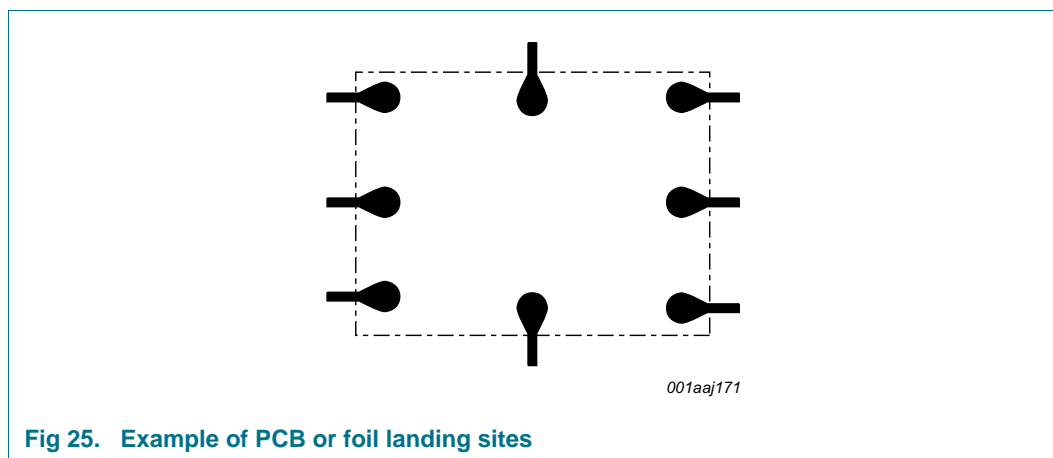

Fig 25. Example of PCB or foil landing sites

11. Safety notes

CAUTION



This device is sensitive to ElectroStatic Discharge (ESD). Observe precautions for handling electrostatic sensitive devices.

Such precautions are described in the *ANSI/ESD S20.20*, *IEC/ST 61340-5*, *JESD625-A* or equivalent standards.

CAUTION



Semiconductors are light sensitive. Exposure to light sources can cause the IC to malfunction. The IC must be protected against light. The protection must be applied to all sides of the IC.

12. Limiting values

Table 12. Limiting values

In accordance with the Absolute Maximum Rating System (IEC 60134).

Symbol	Parameter	Conditions	Min	Max	Unit	
V _{DD}	supply voltage		-0.5	+6.5	V	
I _{DD}	supply current		-50	+50	mA	
V _I	input voltage		-0.5	+6.5	V	
I _I	input current		-10	+10	mA	
V _O	output voltage		-0.5	+6.5	V	
I _O	output current		-10	+10	mA	
P _{tot}	total power dissipation		-	300	mW	
V _{esd}	electrostatic discharge voltage	HBM	[1]	-	±2500	V
		MM	[2]	-	±200	V
I _{lu}	latch-up current		[3]	-	200	mA
T _{amb}	ambient temperature		-40	+85	°C	
T _{stg}	storage temperature		[4]	-65	+150	°C

[1] Pass level; Human Body Model (HBM) according to JESD22-A114.

[2] Pass level; Machine Model (MM), according to JESD22-A115.

[3] Pass level; Latch-up testing, according to JESD78.

[4] According to the store and transport requirements (see [Ref. 11 "UM10569"](#)) the devices have to be stored at a temperature of +8 °C to +45 °C and a humidity of 25 % to 75 %.

13. Static characteristics

Table 13. Static characteristics

$V_{DD} = 1.6\text{ V to }5.5\text{ V}$; $V_{SS} = 0\text{ V}$; $f_{osc} = 32.768\text{ kHz}$; $T_{amb} = -40\text{ }^{\circ}\text{C to }+85\text{ }^{\circ}\text{C}$; quartz crystal: $R_s = 30\text{ k}\Omega$, $C_L = 6.0\text{ pF}$; unless otherwise specified.

Symbol	Parameter	Conditions	Min	Typ	Max	Unit
Supplies						
V_{DD}	supply voltage		1.6	-	5.5	V
		$T_{amb} = 25\text{ }^{\circ}\text{C}$; $f_{SCL} = 0\text{ Hz}$	-	1.0	-	V
ΔV_{DD}	supply voltage variation	$\Delta V/\Delta t = 1\text{ V}/\mu\text{s}$	-	0.25	-	V
I_{DD}	supply current	deep sleep active [1]				
		$T_{amb} = 25\text{ }^{\circ}\text{C}$; $V_{DD} = 3\text{ V}$; $f_{SCL} = 0\text{ Hz}$	-	3	-	nA
		device running				
		$f_{SCL} = 0\text{ Hz}$	-	-	400	nA
		$T_{amb} = 25\text{ }^{\circ}\text{C}$; $V_{DD} = 3\text{ V}$; $f_{SCL} = 0\text{ Hz}$	-	130	-	nA
		interface active				
		$f_{SCL} = 100\text{ kHz}$	-	5	20	μA
$f_{SCL} = 1\text{ MHz}$	-	50	100	μA		
Oscillator						
V_{start}	start voltage		-	1.1	-	V
$t_{startup}$	start-up time		-	0.2	-	s
$C_{L(itg)}$	integrated load capacitance	[2]	-	6.0	-	pF
Inputs						
V_{IL}	LOW-level input voltage		-	-	$0.3V_{DD}$	V
V_{IH}	HIGH-level input voltage		$0.7V_{DD}$	-	-	V
V_I	input voltage	on pins SCL, OSCI, TEST	-0.5	-	5.5	V
		on pin SDA	-0.5	-	$V_{DD} + 0.5$	V
I_{LI}	input leakage current	$V_I = V_{DD}$ or V_{SS} ; on pins SCL, SDA and TEST	-200	0	+200	nA
Outputs						
V_O	output voltage		-0.5	-	$V_{DD}+0.5$	V
I_{OH}	HIGH-level output current	$V_{OH} = 4.0\text{ V}$; $V_{DD} = 5\text{ V}$; on pins $\overline{\text{INT}}$ and SDA	-	5	2	mA
		$V_{OH} = 1.28\text{ V}$; $V_{DD} = 1.6\text{ V}$; on pins $\overline{\text{INT}}$ and SDA	-	0.5	0.2	mA

Table 13. Static characteristics ...continued

$V_{DD} = 1.6\text{ V to }5.5\text{ V}$; $V_{SS} = 0\text{ V}$; $f_{osc} = 32.768\text{ kHz}$; $T_{amb} = -40\text{ °C to }+85\text{ °C}$; quartz crystal: $R_s = 30\text{ k}\Omega$, $C_L = 6.0\text{ pF}$; unless otherwise specified.

Symbol	Parameter	Conditions	Min	Typ	Max	Unit
I _{OL}	LOW-level output current	$V_{OL} = 1.0\text{ V}$; $V_{DD} = 5\text{ V}$; on pins $\overline{\text{INT}}$ and SDA	-2	-7	-	mA
		$V_{OL} = 0.32\text{ V}$; $V_{DD} = 1.6\text{ V}$; on pins $\overline{\text{INT}}$ and SDA	-0.4	-1	-	mA
I _{LO}	output leakage current	$V_O = V_{DD}$ or V_{SS} ; on pins SDA and $\overline{\text{INT}}$	-200	0	+200	nA

[1] Unless otherwise defined, I_{DD} is measured with the reset state, see [Section 9.7](#).

[2] Integrated load capacitance, C_{L(itg)}, is a calculation of C_{OSCI} and C_{OSCO} in series: $C_{L(itg)} = \frac{(C_{OSCI} \cdot C_{OSCO})}{(C_{OSCI} + C_{OSCO})}$.

14. Dynamic characteristics

Table 14. Dynamic characteristics

$V_{DD} = 1.6\text{ V to }5.5\text{ V}$; $V_{SS} = 0\text{ V}$; $T_{amb} = -40\text{ }^{\circ}\text{C to }+85\text{ }^{\circ}\text{C}$; unless otherwise specified. [1]

Symbol	Parameter	Conditions	Min	Typ	Max	Unit
Timing characteristics: serial bus						
f_{SCL}	SCL clock frequency		-	-	1	MHz
t_{LOW}	LOW period of the SCL clock		500	-	-	ns
t_{HIGH}	HIGH period of the SCL clock		260	-	-	ns
t_{BUF}	bus free time between a STOP and START condition		500	-	-	ns
$t_{HD;STA}$	hold time (repeated) START condition		260	-	-	ns
$t_{SU;STA}$	set-up time for a repeated START condition		260	-	-	ns
t_r	rise time of both SDA and SCL signals	[2]	-	10	-	ns
t_f	fall time of both SDA and SCL signals	[2]	-	10	-	ns
$t_{SU;DAT}$	data set-up time		50	-	-	ns
$t_{HD;DAT}$	data hold time		0	-	-	ns
$t_{SU;STO}$	set-up time for STOP condition		260	-	-	ns
$t_{VD;DAT}$	data valid time		75	-	450	ns
C_b	capacitive load for each bus line		-	-	50	pF
Timing characteristics: INT						
$t_{w(int)}$	interrupt pulse width		20	40	80	μs

[1] All timing values are valid within the operating supply voltage and ambient temperature range and are referenced to V_{IL} and V_{IH} with an input voltage swing of V_{SS} to V_{DD} .

[2] Rise and fall times are not limited. Fast edges can lead to system EMI problems, while slow edges are susceptible to noise.

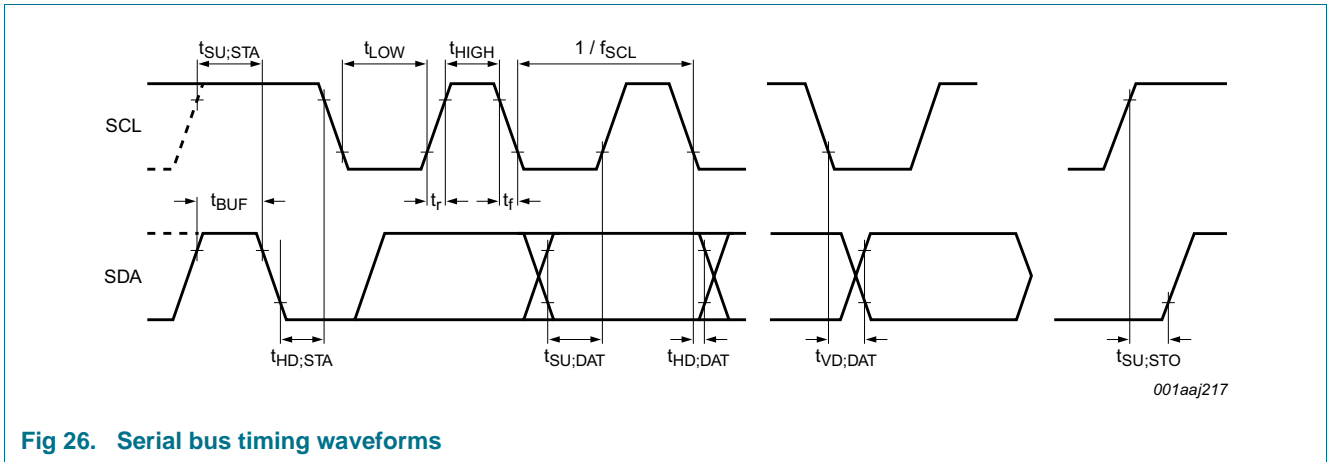

Fig 26. Serial bus timing waveforms

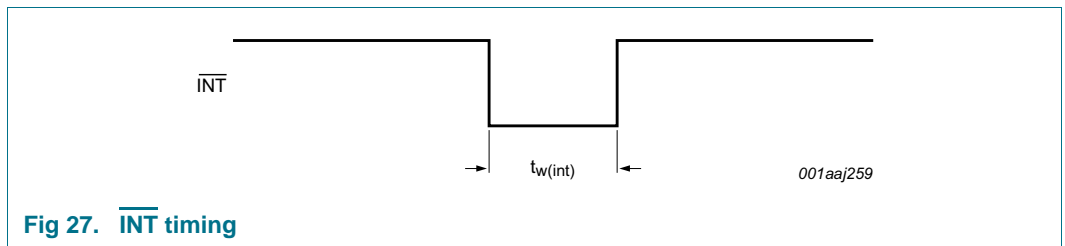

Fig 27. \overline{INT} timing

15. Bare die outline

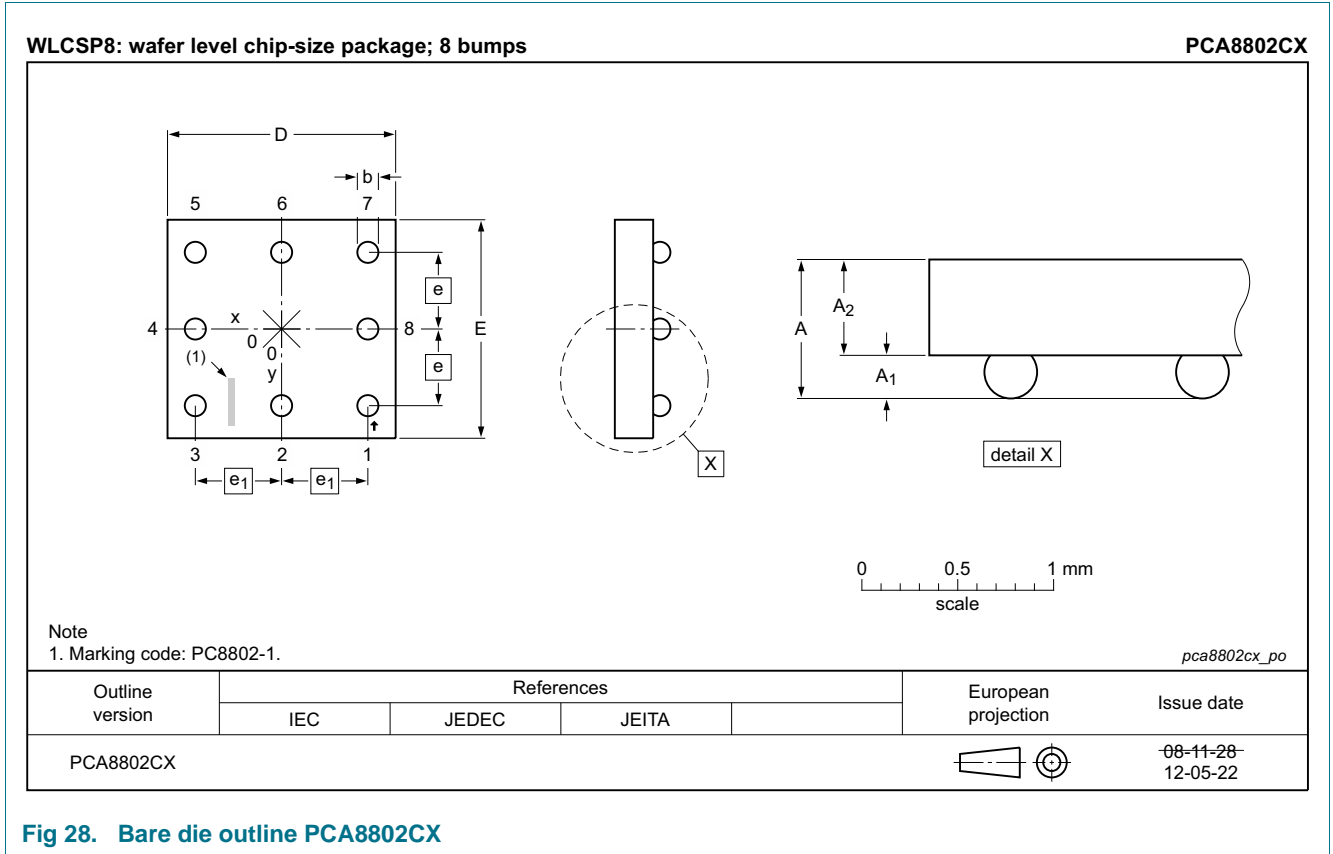

Fig 28. Bare die outline PCA8802CX

Table 15. Dimensions of PCA8802CX

Original dimensions are in mm.

Unit (mm)	A	A ₁	A ₂	b	D	E	e	e ₁	e _D
max	-	0.105	-	0.136	-	-	-	-	-
nom	0.29	0.090	0.2	0.109	1.19	1.14	0.4	0.45	0.96
min	-	0.075	-	0.082	-	-	-	-	-

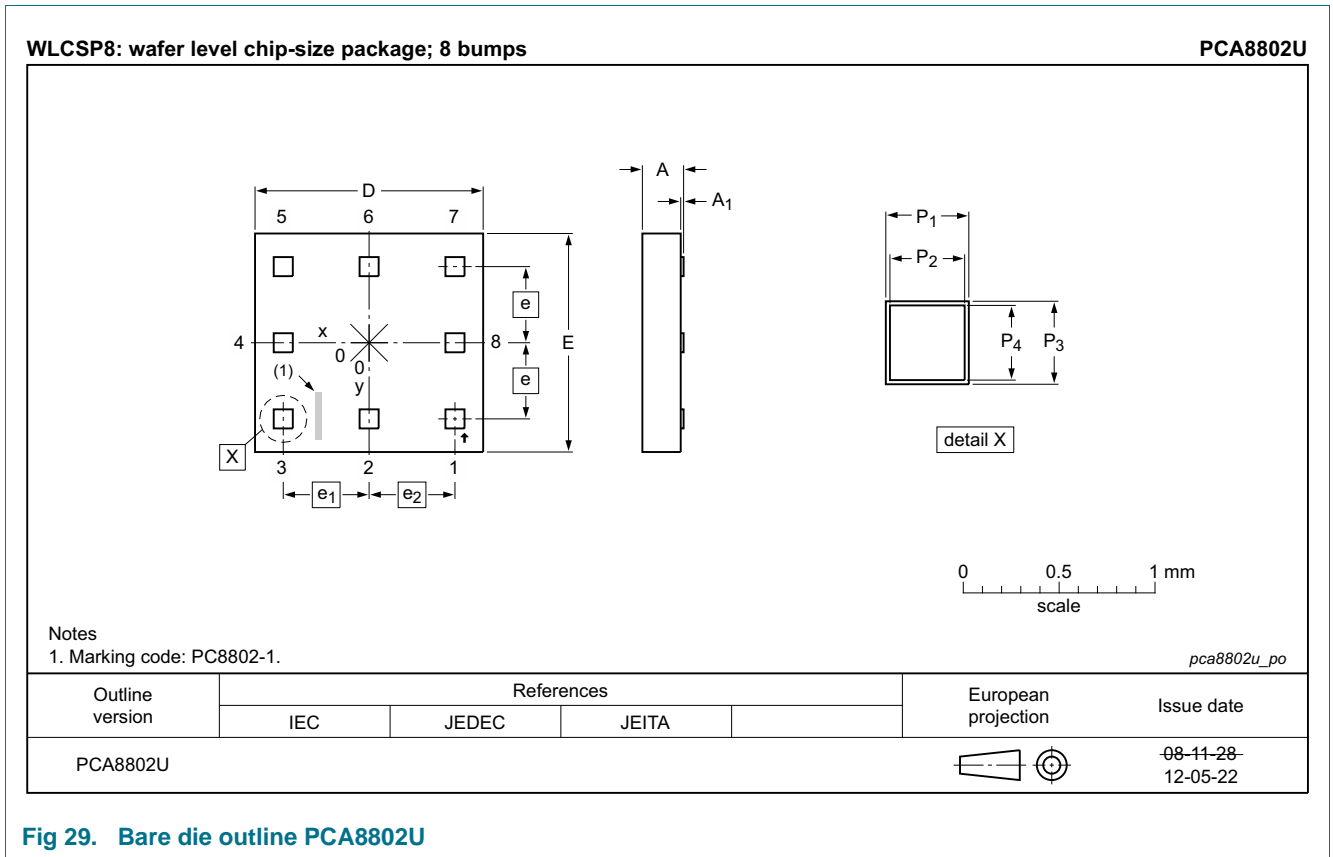

Fig 29. Bare die outline PCA8802U

Table 16. Dimensions of PCA8802U and PCA8802UG

Original dimensions are in mm.

Unit (mm)	A	A ₁	D ^[1]	E ^[1]	e	e ₁	e ₂	P ₁ ^[2]	P ₂ ^[3]	P ₃ ^[2]	P ₄ ^[3]
PCA8802U/2AA/1 and PCA8802U/12AA/1											
max	-	0.018	-	-	-	-	-	-	0.093	-	0.093
nom	0.215	0.015	1.19	1.14	0.396	0.448	0.449	0.099	0.090	0.099	0.090
min	-	0.012	-	-	-	-	-	-	0.087	-	0.087
PCA8802UG/12KB/1											
max	-	0.018	-	-	-	-	-	-	0.093	-	0.093
nom	0.265	0.015	1.19	1.14	0.396	0.448	0.449	0.099	0.090	0.099	0.090
min	-	0.012	-	-	-	-	-	-	0.087	-	0.087

[1] Including saw lane.

[2] Pad size.

[3] Bump size.

Table 17. Bump and reference point locations of PCA8802U and PCA8802UG

Symbol	Pad	Coordinates ^[1]	
		x	y
$\overline{\text{INT}}$	1	437	-396
V _{DD}	2	-12	-430
TEST	3	-460	-396
OSCO	4	-460	1
OSCI	5	-460	396
V _{SS} ^[2]	6	-12	430
SCL	7	437	396
SDA	8	437	1
pin 1 identifier	-	474.7	-472.0
bottom left die corner ^[3]	-	-594.8	-568.2
top right die corner ^[3]	-	594.7	568.3

- [1] All coordinates are referenced, in μm , to the center of the die (see [Figure 29](#)).
- [2] The substrate (rear side of the die) is connected to V_{SS} and should be electrically isolated.
- [3] Die size before dicing. Final dimensions will be 10 μm to 20 μm smaller.

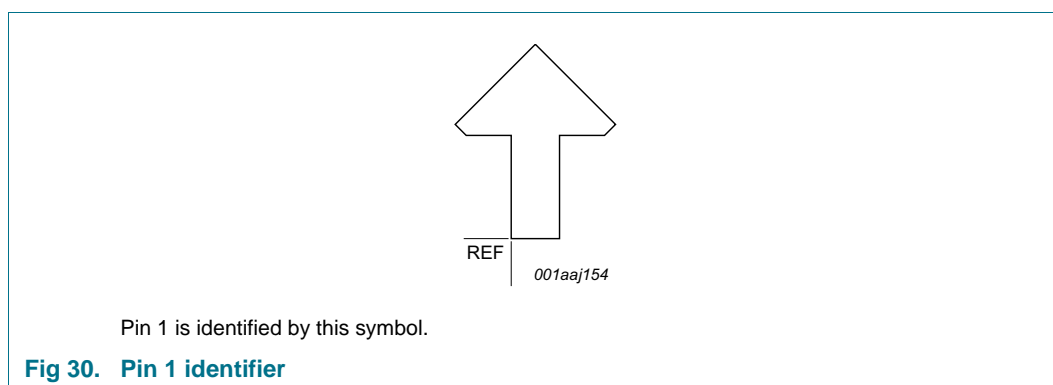

Table 18. Gold bump hardness of PCA8802U and PCA8802UG

Gold bump type	Min	Max	Unit ^[1]
soft gold bump	35	80	HV

- [1] Pressure of diamond head: 10 g to 50 g.

16. Handling information

All input and output pins are protected against ElectroStatic Discharge (ESD) under normal handling. When handling Metal-Oxide Semiconductor (MOS) devices ensure that all normal precautions are taken as described in *JESD625-A*, *IEC 61340-5* or equivalent standards.

17. Packing information

17.1 Tape and reel information for PCA8802CX8/B/1

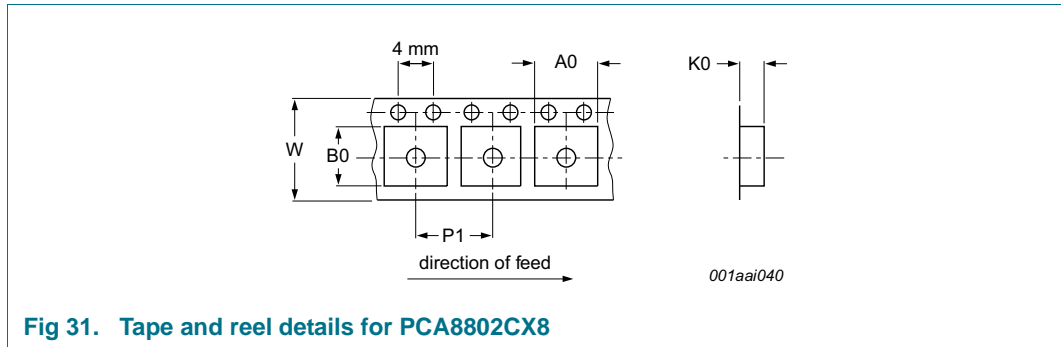
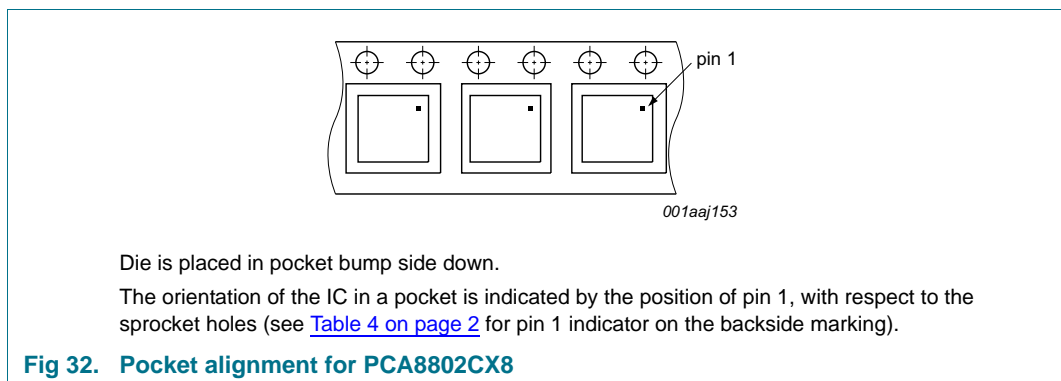

Table 19. Tape and reel dimensions

Dimension	Description	Value
W	tape width	8.0 mm
A0	pocket length	1.3 mm
B0	pocket width	1.3 mm
K0	pocket depth	0.5 mm
P1	pocket pitch	4.0 mm



17.2 Wafer and Film Frame Carrier (FFC) information for PCA8802U/12AA/1 and PCA8802UG/12KB/1

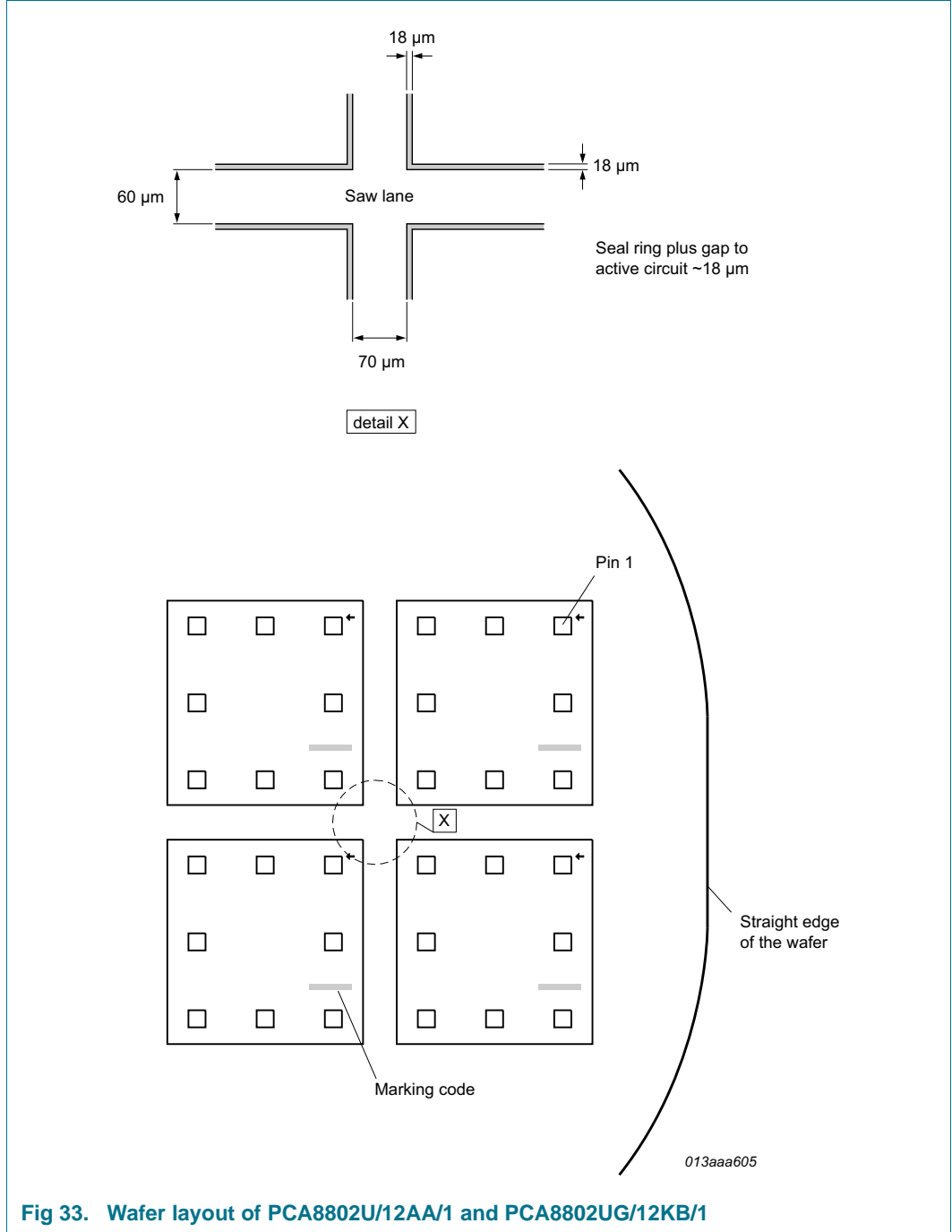

Fig 33. Wafer layout of PCA8802U/12AA/1 and PCA8802UG/12KB/1

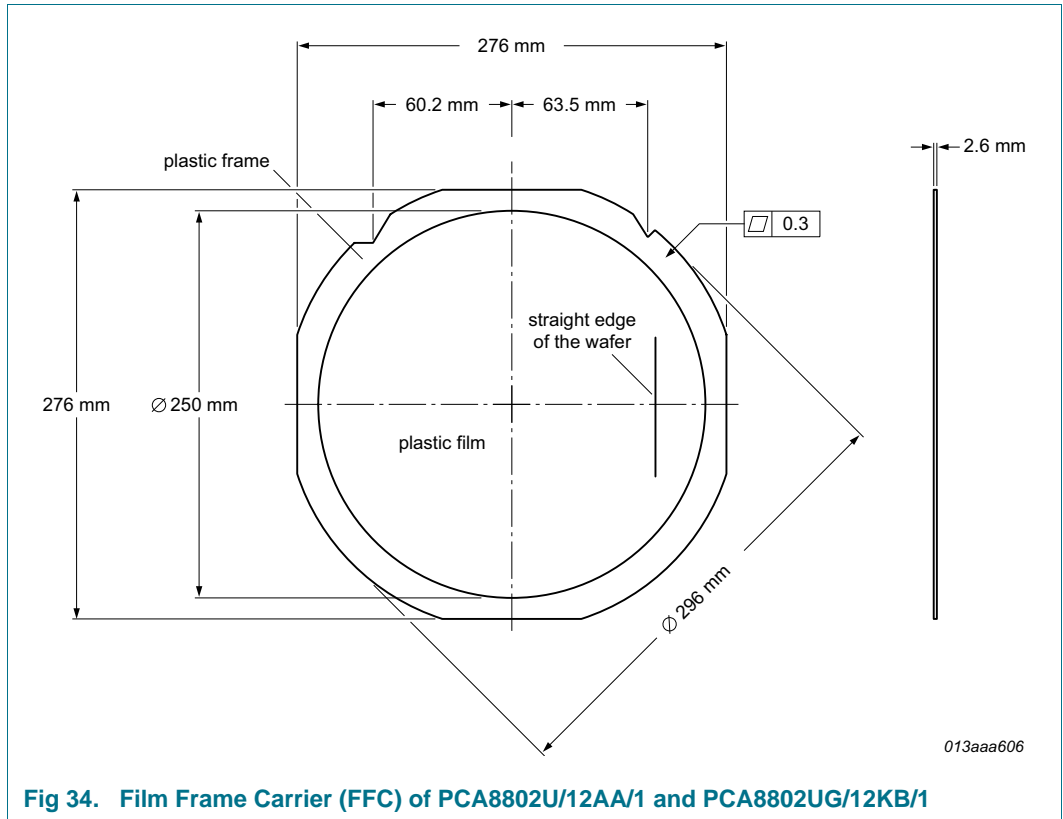

Fig 34. Film Frame Carrier (FFC) of PCA8802U/12AA/1 and PCA8802UG/12KB/1

17.3 Tray information for PCA8802U/2AA/1

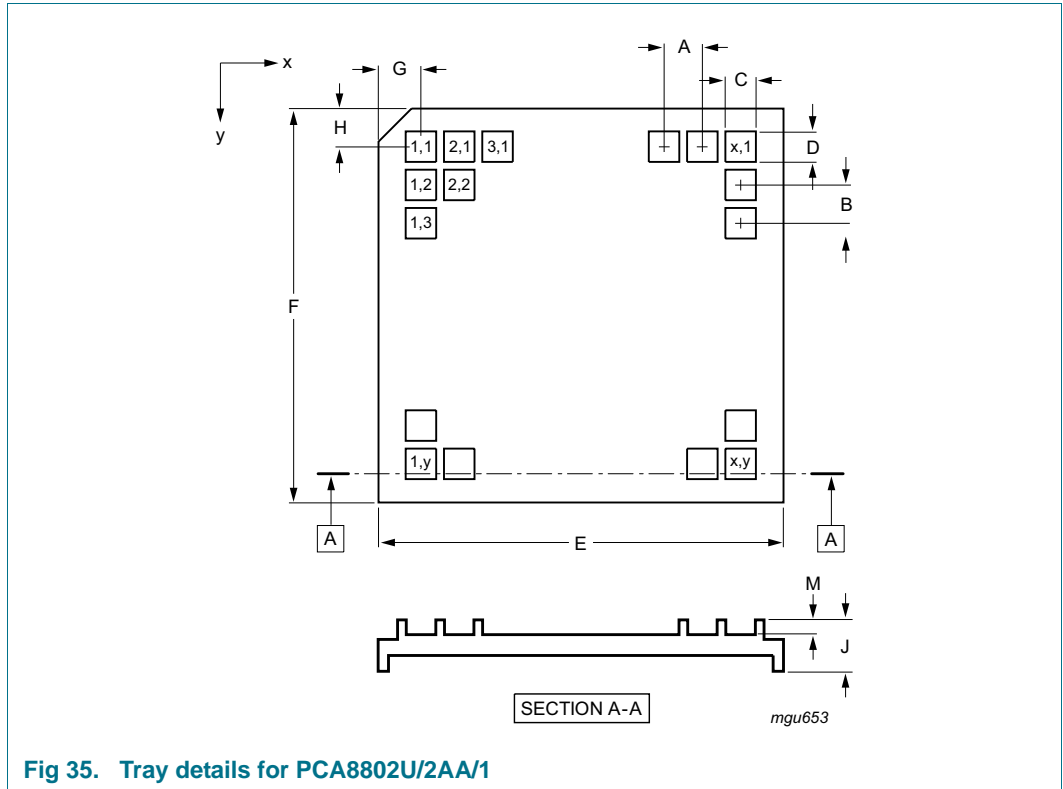
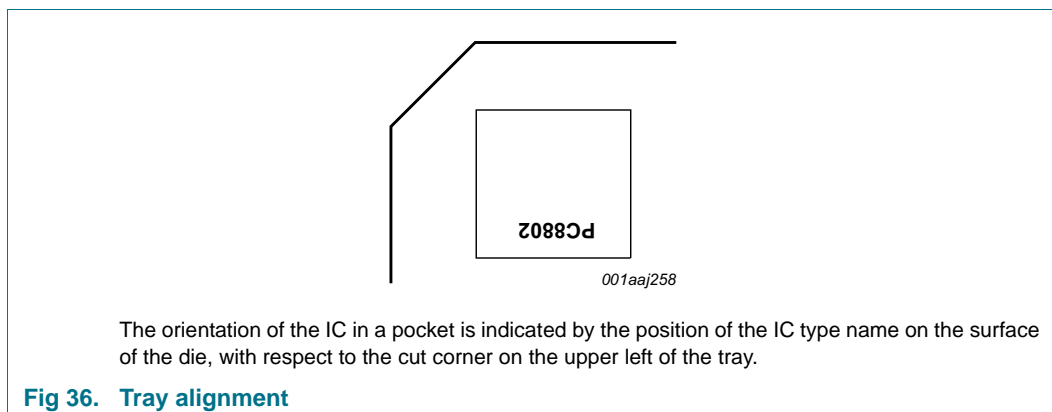

Fig 35. Tray details for PCA8802U/2AA/1

Table 20. Tray dimensions [1]

Dimension	Description	Value
A	pocket pitch; x direction	3.1 mm
B	pocket pitch; y direction	3.1 mm
C	pocket width; x direction	1.29 mm
D	pocket width; y direction	1.24 mm
E	tray width; x direction	50.8 mm
F	tray width; y direction	50.8 mm
G	distance from cut corner to pocket (1,1) center	5.25 mm
H	distance from cut corner to pocket (1,1) center	5.25 mm
J	tray thickness	3.96 mm
M	pocket depth	0.5 mm
x	number of pockets in x direction	14
y	number of pockets in y direction	14

[1] Die is placed in pocket bump side up.



18. Soldering of WLCSP packages

18.1 Introduction to soldering WLCSP packages

This text provides a very brief insight into a complex technology. A more in-depth account of soldering WLCSP (Wafer Level Chip-Size Packages) can be found in application note AN10439 "Wafer Level Chip Scale Package" and in application note AN10365 "Surface mount reflow soldering description".

Wave soldering is not suitable for this package.

All NXP WLCSP packages are lead-free.

18.2 Board mounting

Board mounting of a WLCSP requires several steps:

1. Solder paste printing on the PCB
2. Component placement with a pick and place machine
3. The reflow soldering itself

18.3 Reflow soldering

Key characteristics in reflow soldering are:

- Lead-free versus SnPb soldering; note that a lead-free reflow process usually leads to higher minimum peak temperatures (see [Figure 37](#)) than a SnPb process, thus reducing the process window
- Solder paste printing issues, such as smearing, release, and adjusting the process window for a mix of large and small components on one board
- Reflow temperature profile; this profile includes preheat, reflow (in which the board is heated to the peak temperature), and cooling down. It is imperative that the peak temperature is high enough for the solder to make reliable solder joints (a solder paste characteristic) while being low enough that the packages and/or boards are not damaged. The peak temperature of the package depends on package thickness and volume and is classified in accordance with [Table 21](#).

Table 21. Lead-free process (from J-STD-020D)

Package thickness (mm)	Package reflow temperature (°C)		
	Volume (mm ³)		
	< 350	350 to 2000	> 2000
< 1.6	260	260	260
1.6 to 2.5	260	250	245
> 2.5	250	245	245

Moisture sensitivity precautions, as indicated on the packing, must be respected at all times.

Studies have shown that small packages reach higher temperatures during reflow soldering, see [Figure 37](#).

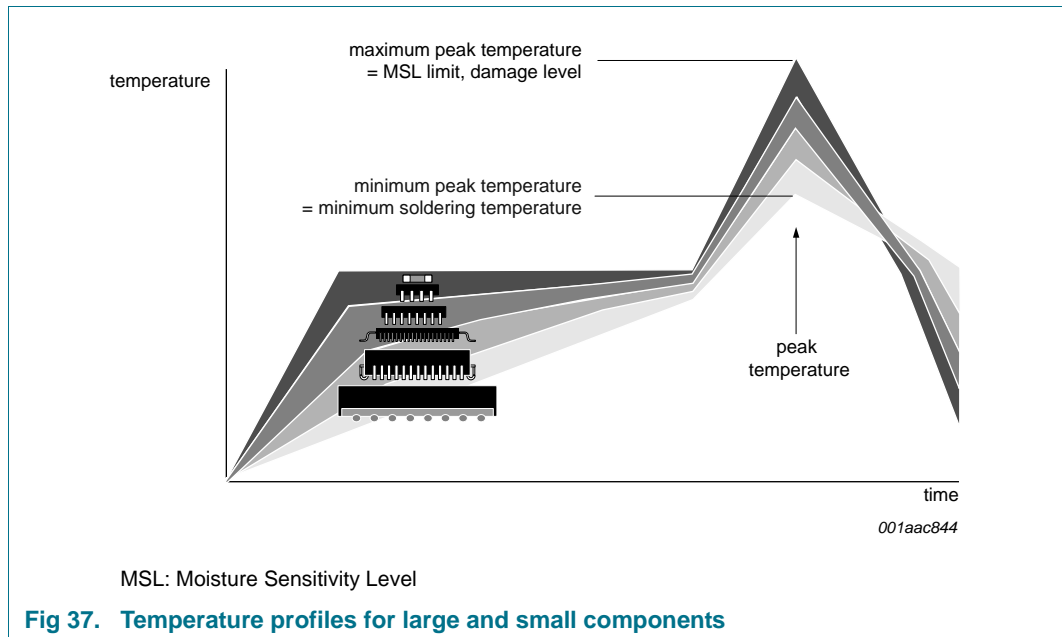

For further information on temperature profiles, refer to application note *AN10365 "Surface mount reflow soldering description"*.

18.3.1 Stand off

The stand off between the substrate and the chip is determined by:

- The amount of printed solder on the substrate
- The size of the solder land on the substrate
- The bump height on the chip

The higher the stand off, the better the stresses are released due to TEC (Thermal Expansion Coefficient) differences between substrate and chip.

18.3.2 Quality of solder joint

A flip-chip joint is considered to be a good joint when the entire solder land has been wetted by the solder from the bump. The surface of the joint should be smooth and the shape symmetrical. The soldered joints on a chip should be uniform. Voids in the bumps after reflow can occur during the reflow process in bumps with high ratio of bump diameter to bump height, i.e. low bumps with large diameter. No failures have been found to be related to these voids. Solder joint inspection after reflow can be done with X-ray to monitor defects such as bridging, open circuits and voids.

18.3.3 Rework

In general, rework is not recommended. By rework we mean the process of removing the chip from the substrate and replacing it with a new chip. If a chip is removed from the substrate, most solder balls of the chip will be damaged. In that case it is recommended not to re-use the chip again.

Device removal can be done when the substrate is heated until it is certain that all solder joints are molten. The chip can then be carefully removed from the substrate without damaging the tracks and solder lands on the substrate. Removing the device must be done using plastic tweezers, because metal tweezers can damage the silicon. The surface of the substrate should be carefully cleaned and all solder and flux residues and/or underfill removed. When a new chip is placed on the substrate, use the flux process instead of solder on the solder lands. Apply flux on the bumps at the chip side as well as on the solder pads on the substrate. Place and align the new chip while viewing with a microscope. To reflow the solder, use the solder profile shown in application note AN10365 “Surface mount reflow soldering description”.

18.3.4 Cleaning

Cleaning can be done after reflow soldering.

19. Abbreviations

Table 22. Abbreviations

Acronym	Description
CMOS	Complementary Metal Oxide Semiconductor
EMI	ElectroMagnetic Interference
HBM	Human Body Model
IC	Integrated Circuit
LCD	Liquid Crystal Display
LSB	Least Significant Bit
MM	Machine Model
MSB	Most Significant Bit
PCB	Printed-Circuit Board
RTC	Real-Time Clock
WLCSP	Wafer Level Chip-Size Package

20. References

- [1] **AN10439** — Wafer Level Chip Size Package
- [2] **AN10706** — Handling bare die
- [3] **AN10853** — ESD and EMC sensitivity of IC
- [4] **IEC 60134** — Rating systems for electronic tubes and valves and analogous semiconductor devices
- [5] **IEC 61340-5** — Protection of electronic devices from electrostatic phenomena
- [6] **JESD22-A114** — Electrostatic Discharge (ESD) Sensitivity Testing Human Body Model (HBM)
- [7] **JESD22-A115** — Electrostatic Discharge (ESD) Sensitivity Testing Machine Model (MM)
- [8] **JESD78** — IC Latch-Up Test
- [9] **JESD625-A** — Requirements for Handling Electrostatic-Discharge-Sensitive (ESDS) Devices
- [10] **UM10204** — I²C-bus specification and user manual
- [11] **UM10569** — Store and transport requirements

21. Revision history

Table 23. Revision history

Document ID	Release date	Data sheet status	Change notice	Supersedes
PCA8802 v.6	20140701	Product data sheet	-	PCA8802 v.5
Modifications:	<ul style="list-style-type: none"> • The format of this data sheet has been redesigned to comply with the new identity guidelines of NXP Semiconductors. • Legal texts have been adapted to the new company name where appropriate. • Changed description of Figure 2 and Figure 3 • Updated information in Table 4 • Enhanced description of Table 5 • Enhanced description of Section 9.5 			
PCA8802 v.5	20130305	Product data sheet	-	PCA8802 v.4
PCA8802 v.4	20120927	Product data sheet	-	PCA8802 v.3
PCA8802 v.3	20120330	Product data sheet	-	PCA8802 v.2
PCA8802 v.2	20120126	Product data sheet	-	PCA8802_1
PCA8802_1	20090219	Product data sheet	-	-

22. Legal information

22.1 Data sheet status

Document status ^{[1][2]}	Product status ^[3]	Definition
Objective [short] data sheet	Development	This document contains data from the objective specification for product development.
Preliminary [short] data sheet	Qualification	This document contains data from the preliminary specification.
Product [short] data sheet	Production	This document contains the product specification.

[1] Please consult the most recently issued document before initiating or completing a design.

[2] The term 'short data sheet' is explained in section "Definitions".

[3] The product status of device(s) described in this document may have changed since this document was published and may differ in case of multiple devices. The latest product status information is available on the Internet at URL <http://www.nxp.com>.

22.2 Definitions

Draft — The document is a draft version only. The content is still under internal review and subject to formal approval, which may result in modifications or additions. NXP Semiconductors does not give any representations or warranties as to the accuracy or completeness of information included herein and shall have no liability for the consequences of use of such information.

Short data sheet — A short data sheet is an extract from a full data sheet with the same product type number(s) and title. A short data sheet is intended for quick reference only and should not be relied upon to contain detailed and full information. For detailed and full information see the relevant full data sheet, which is available on request via the local NXP Semiconductors sales office. In case of any inconsistency or conflict with the short data sheet, the full data sheet shall prevail.

Product specification — The information and data provided in a Product data sheet shall define the specification of the product as agreed between NXP Semiconductors and its customer, unless NXP Semiconductors and customer have explicitly agreed otherwise in writing. In no event however, shall an agreement be valid in which the NXP Semiconductors product is deemed to offer functions and qualities beyond those described in the Product data sheet.

22.3 Disclaimers

Limited warranty and liability — Information in this document is believed to be accurate and reliable. However, NXP Semiconductors does not give any representations or warranties, expressed or implied, as to the accuracy or completeness of such information and shall have no liability for the consequences of use of such information. NXP Semiconductors takes no responsibility for the content in this document if provided by an information source outside of NXP Semiconductors.

In no event shall NXP Semiconductors be liable for any indirect, incidental, punitive, special or consequential damages (including - without limitation - lost profits, lost savings, business interruption, costs related to the removal or replacement of any products or rework charges) whether or not such damages are based on tort (including negligence), warranty, breach of contract or any other legal theory.

Notwithstanding any damages that customer might incur for any reason whatsoever, NXP Semiconductors' aggregate and cumulative liability towards customer for the products described herein shall be limited in accordance with the *Terms and conditions of commercial sale* of NXP Semiconductors.

Right to make changes — NXP Semiconductors reserves the right to make changes to information published in this document, including without limitation specifications and product descriptions, at any time and without notice. This document supersedes and replaces all information supplied prior to the publication hereof.

Suitability for use — NXP Semiconductors products are not designed, authorized or warranted to be suitable for use in life support, life-critical or safety-critical systems or equipment, nor in applications where failure or malfunction of an NXP Semiconductors product can reasonably be expected to result in personal injury, death or severe property or environmental damage. NXP Semiconductors and its suppliers accept no liability for inclusion and/or use of NXP Semiconductors products in such equipment or applications and therefore such inclusion and/or use is at the customer's own risk.

Applications — Applications that are described herein for any of these products are for illustrative purposes only. NXP Semiconductors makes no representation or warranty that such applications will be suitable for the specified use without further testing or modification.

Customers are responsible for the design and operation of their applications and products using NXP Semiconductors products, and NXP Semiconductors accepts no liability for any assistance with applications or customer product design. It is customer's sole responsibility to determine whether the NXP Semiconductors product is suitable and fit for the customer's applications and products planned, as well as for the planned application and use of customer's third party customer(s). Customers should provide appropriate design and operating safeguards to minimize the risks associated with their applications and products.

NXP Semiconductors does not accept any liability related to any default, damage, costs or problem which is based on any weakness or default in the customer's applications or products, or the application or use by customer's third party customer(s). Customer is responsible for doing all necessary testing for the customer's applications and products using NXP Semiconductors products in order to avoid a default of the applications and the products or of the application or use by customer's third party customer(s). NXP does not accept any liability in this respect.

Limiting values — Stress above one or more limiting values (as defined in the Absolute Maximum Ratings System of IEC 60134) will cause permanent damage to the device. Limiting values are stress ratings only and (proper) operation of the device at these or any other conditions above those given in the Recommended operating conditions section (if present) or the Characteristics sections of this document is not warranted. Constant or repeated exposure to limiting values will permanently and irreversibly affect the quality and reliability of the device.

Terms and conditions of commercial sale — NXP Semiconductors products are sold subject to the general terms and conditions of commercial sale, as published at <http://www.nxp.com/profile/terms>, unless otherwise agreed in a valid written individual agreement. In case an individual agreement is concluded only the terms and conditions of the respective agreement shall apply. NXP Semiconductors hereby expressly objects to applying the customer's general terms and conditions with regard to the purchase of NXP Semiconductors products by customer.

No offer to sell or license — Nothing in this document may be interpreted or construed as an offer to sell products that is open for acceptance or the grant, conveyance or implication of any license under any copyrights, patents or other industrial or intellectual property rights.

Export control — This document as well as the item(s) described herein may be subject to export control regulations. Export might require a prior authorization from competent authorities.

Non-automotive qualified products — Unless this data sheet expressly states that this specific NXP Semiconductors product is automotive qualified, the product is not suitable for automotive use. It is neither qualified nor tested in accordance with automotive testing or application requirements. NXP Semiconductors accepts no liability for inclusion and/or use of non-automotive qualified products in automotive equipment or applications.

In the event that customer uses the product for design-in and use in automotive applications to automotive specifications and standards, customer (a) shall use the product without NXP Semiconductors' warranty of the product for such automotive applications, use and specifications, and (b) whenever customer uses the product for automotive applications beyond NXP Semiconductors' specifications such use shall be solely at customer's own risk, and (c) customer fully indemnifies NXP Semiconductors for any liability, damages or failed product claims resulting from customer design and use of the product for automotive applications beyond NXP Semiconductors' standard warranty and NXP Semiconductors' product specifications.

Translations — A non-English (translated) version of a document is for reference only. The English version shall prevail in case of any discrepancy between the translated and English versions.

Bare die — All die are tested on compliance with their related technical specifications as stated in this data sheet up to the point of wafer sawing and are handled in accordance with the NXP Semiconductors storage and transportation conditions. If there are data sheet limits not guaranteed, these will be separately indicated in the data sheet. There are no post-packing tests performed on individual die or wafers.

NXP Semiconductors has no control of third party procedures in the sawing, handling, packing or assembly of the die. Accordingly, NXP Semiconductors assumes no liability for device functionality or performance of the die or systems after third party sawing, handling, packing or assembly of the die. It is the responsibility of the customer to test and qualify their application in which the die is used.

All die sales are conditioned upon and subject to the customer entering into a written die sale agreement with NXP Semiconductors through its legal department.

22.4 Trademarks

Notice: All referenced brands, product names, service names and trademarks are the property of their respective owners.

I²C-bus — logo is a trademark of NXP Semiconductors N.V.

23. Contact information

For more information, please visit: <http://www.nxp.com>

For sales office addresses, please send an email to: salesaddresses@nxp.com

24. Tables

Table 1.	Ordering information	2
Table 2.	Ordering options	2
Table 3.	PCA8802 wafer information	2
Table 4.	Marking codes	2
Table 5.	Pin description for PCA8802	5
Table 6.	Instruction set overview	6
Table 7.	Write instructions	15
Table 8.	Read instructions	15
Table 9.	Deep sleep mode sequence	17
Table 10.	Example of accurate setting of the counter	18
Table 11.	Reset state	19
Table 12.	Limiting values	20
Table 13.	Static characteristics	21
Table 14.	Dynamic characteristics	23
Table 15.	Dimensions of PCA8802CX	25
Table 16.	Dimensions of PCA8802U and PCA8802UG	26
Table 17.	Bump and reference point locations of PCA8802U and PCA8802UG	27
Table 18.	Gold bump hardness of PCA8802U and PCA8802UG	27
Table 19.	Tape and reel dimensions	28
Table 20.	Tray dimensions [1]	31
Table 21.	Lead-free process (from J-STD-020D)	33
Table 22.	Abbreviations	35
Table 23.	Revision history	37

25. Figures

Fig 1.	Block diagram of PCA8802	3
Fig 2.	Pinning diagram of PCA8802CX8	4
Fig 3.	Pinning diagram of PCA8802U and PCA8802UG	4
Fig 4.	Diode protection diagram.	5
Fig 5.	I_{DD} with respect to R_s .	7
Fig 6.	Divider chain	7
Fig 7.	Counter behavior during read access	8
Fig 8.	Pulse generator	9
Fig 9.	Writing protocol	10
Fig 10.	Reading protocol	10
Fig 11.	Access restrictions	10
Fig 12.	Bit transfer	11
Fig 13.	Bit transfer	11
Fig 14.	Definition of START and STOP conditions.	11
Fig 15.	Acknowledgement on the I ² C-bus	12
Fig 16.	A complete data transfer	13
Fig 17.	A master-transmitter addresses a slave receiver.	13
Fig 18.	A master reads from a slave immediately after the first byte.	13
Fig 19.	Combined format	13
Fig 20.	Sending instructions	14
Fig 21.	Setting the counter	14
Fig 22.	Reading the counter	14
Fig 23.	Instruction <code>dvs_cmd</code> .	16
Fig 24.	Read bit order	18
Fig 25.	Example of PCB or foil landing sites	19
Fig 26.	Serial bus timing waveforms	24
Fig 27.	INT timing	24
Fig 28.	Bare die outline PCA8802CX	25
Fig 29.	Bare die outline PCA8802U	26
Fig 30.	Pin 1 identifier	27
Fig 31.	Tape and reel details for PCA8802CX8	28
Fig 32.	Pocket alignment for PCA8802CX8	28
Fig 33.	Wafer layout of PCA8802U/12AA/1 and PCA8802UG/12KB/1	29
Fig 34.	Film Frame Carrier (FFC) of PCA8802U/12AA/1 and PCA8802UG/12KB/1	30
Fig 35.	Tray details for PCA8802U/2AA/1	31
Fig 36.	Tray alignment	32
Fig 37.	Temperature profiles for large and small components	34

26. Contents

1	General description	1	14	Dynamic characteristics	23
2	Features and benefits	1	15	Bare die outline	25
3	Applications	1	16	Handling information	27
4	Ordering information	2	17	Packing information	28
4.1	Ordering options	2	17.1	Tape and reel information for PCA8802CX8/B/1	28
5	Marking	2	17.2	Wafer and Film Frame Carrier (FFC) information for PCA8802U/12AA/1 and PCA8802UG/12KB/1	29
6	Block diagram	3	17.3	Tray information for PCA8802U/2AA/1	31
7	Pinning information	4	18	Soldering of WLCSP packages	33
7.1	Pinning	4	18.1	Introduction to soldering WLCSP packages	33
7.2	Pin description	5	18.2	Board mounting	33
8	Device protection diagram	5	18.3	Reflow soldering	33
9	Functional description	6	18.3.1	Stand off	34
9.1	Oscillator	6	18.3.2	Quality of solder joint	34
9.1.1	Low-power operation	6	18.3.3	Rework	34
9.1.2	Deep sleep mode	7	18.3.4	Cleaning	35
9.2	Divider	7	19	Abbreviations	35
9.3	Binary counter	8	20	References	36
9.4	Pulse generator	8	21	Revision history	37
9.5	I ² C-bus interface	9	22	Legal information	38
9.5.1	Interface protocol	9	22.1	Data sheet status	38
9.5.1.1	The writing protocol	9	22.2	Definitions	38
9.5.1.2	The reading protocol	10	22.3	Disclaimers	38
9.5.1.3	Reading and writing limitations	10	22.4	Trademarks	39
9.5.2	Bit transfer	11	23	Contact information	39
9.5.3	Bit order	11	24	Tables	40
9.5.4	START and STOP conditions	11	25	Figures	41
9.5.5	System configuration	11	26	Contents	42
9.5.6	Acknowledge	12			
9.5.7	Data transfer	13			
9.5.7.1	Example data transfers	14			
9.6	Instructions	15			
9.6.1	Instruction set	15			
9.6.2	Instruction wrt_cmd	15			
9.6.3	Instruction dvs_cmd	15			
9.6.4	Instruction pwd_cmd	16			
9.6.5	Instruction 32k_cmd	17			
9.6.6	Instruction fst_cmd	17			
9.6.7	Instruction set_cmd	17			
9.6.8	Instruction rd_cmd	18			
9.7	Power-on reset	19			
10	Application design-in information	19			
10.1	PCB or foil landing site	19			
11	Safety notes	20			
12	Limiting values	20			
13	Static characteristics	21			

Please be aware that important notices concerning this document and the product(s) described herein, have been included in section 'Legal information'.

© NXP Semiconductors N.V. 2014.

All rights reserved.

For more information, please visit: <http://www.nxp.com>

For sales office addresses, please send an email to: salesaddresses@nxp.com

Date of release: 1 July 2014

Document identifier: PCA8802



Looking for pricing, stock, or lifecycle information?

Click below to explore more details on WIN SOURCE:

 [View PCA8802CX8/B/1 on WIN SOURCE](#)

 [NXP / Nexperia Information](#)

Optimize Your Supply Chain with WIN SOURCE Solutions

-  Global Sourcing Solution
-  Obsolete Management
-  Cost Control Management
-  Shortage Management
-  Alternative Solution
-  Excess Inventory Management