

# DATA SHEET

## **PCA8581; PCA8581C** 128 × 8-bit EEPROM with I<sup>2</sup>C-bus interface

Product specification  
Supersedes data of 1996 Aug 19  
File under Integrated Circuits, IC12

1997 Apr 02

**128 × 8-bit EEPROM with I<sup>2</sup>C-bus interface****PCA8581; PCA8581C****CONTENTS**

1	FEATURES
2	GENERAL DESCRIPTION
3	QUICK REFERENCE DATA
4	ORDERING INFORMATION
5	BLOCK DIAGRAM
6	PINNING
7	CHARACTERISTICS OF THE I <sup>2</sup> C-BUS
7.1	Bit transfer
7.2	Start and stop conditions
7.3	System configuration
7.4	Acknowledge
7.5	I <sup>2</sup> C-bus protocol
8	LIMITING VALUES
9	HANDLING
10	DC CHARACTERISTICS
11	AC CHARACTERISTICS
12	APPLICATION INFORMATION
12.2	Application example
12.2	Slave address
12.3	Diode protection
13	PACKAGE OUTLINES
14	SOLDERING
14.1	Introduction
14.2	DIP
14.2.1	Soldering by dipping or by wave
14.2.2	Repairing soldered joints
14.3	SO
14.3.1	Reflow soldering
14.3.2	Wave soldering
14.3.3	Repairing soldered joints
15	DEFINITIONS
16	LIFE SUPPORT APPLICATIONS
17	PURCHASE OF PHILIPS I <sup>2</sup> C COMPONENTS



128 × 8-bit EEPROM with I<sup>2</sup>C-bus interface

## PCA8581; PCA8581C

**1 FEATURES**

- Operating supply voltage:
  - 4.5 to 5.5 V (PCA8581)
  - 2.5 to 6.0 V (PCA8581C)
- Integrated voltage multiplier and timer for writing (no external components required)
- Automatic erase before write
- Low standby current; maximum 10 µA
- 8-byte page write mode
- Serial input/output bus (I<sup>2</sup>C-bus)
- Address by 3 hardware address pins
- Automatic word address incrementing
- Designed for minimum 10000 write cycles per byte
- 10 years minimum non-volatile data retention
- Infinite number of read cycles
- Pin and address compatibility to PCF8570C and PCF8582
- Operating ambient temperature: –25 to +85 °C.

**2 GENERAL DESCRIPTION**

The PCA8581 and PCA8581C are low power CMOS EEPROMs with standard and wide operating voltages:

4.5 to 5.5 V (PCA8581)

2.5 to 6.0 V (PCA8581C).

In the following text, the generic term 'PCA8581' is used to refer to both types in all packages except when otherwise specified.

The PCA8581 is organized as 128 words of 8-bytes.

Addresses and data are transferred serially via a two-line bidirectional bus (I<sup>2</sup>C-bus). The built-in word address register is incremented automatically after each written or read data byte. All bytes can be read in a single operation. Up to 8 bytes can be written in one operation, reducing the total write time per byte. Three address pins, A0, A1 and A2 are used to define the hardware address, allowing the use of up to 8 devices connected to the bus without additional hardware.

**3 QUICK REFERENCE DATA**

SYMBOL	PARAMETER	CONDITIONS	MIN.	MAX.	UNIT
V <sub>DD</sub>	supply voltage				
	PCA8581		4.5	5.5	V
	PCA8581C		2.5	6.0	V
I <sub>DD</sub>	supply current (standby)	f <sub>SCL</sub> = 0 Hz	–	10	µA
T <sub>amb</sub>	operating ambient temperature		–25	+85	°C
T <sub>stg</sub>	storage temperature	without EEPROM retention	–65	+150	°C
		with EEPROM retention	–65	+85	°C

**4 ORDERING INFORMATION**

TYPE NUMBER	PACKAGE		
	NAME	DESCRIPTION	VERSION
PCA8581P	DIP8	plastic dual in-line package; 8 leads (300 mil)	SOT97-1
PCA8581CP	DIP8	plastic dual in-line package; 8 leads (300 mil)	SOT97-1
PCA8581T	SO8	plastic small outline package; 8 leads; body width 3.9 mm	SOT96-1
PCA8581CT	SO8	plastic small outline package; 8 leads; body width 3.9 mm	SOT96-1

128 × 8-bit EEPROM with I<sup>2</sup>C-bus interface

PCA8581; PCA8581C

5 BLOCK DIAGRAM

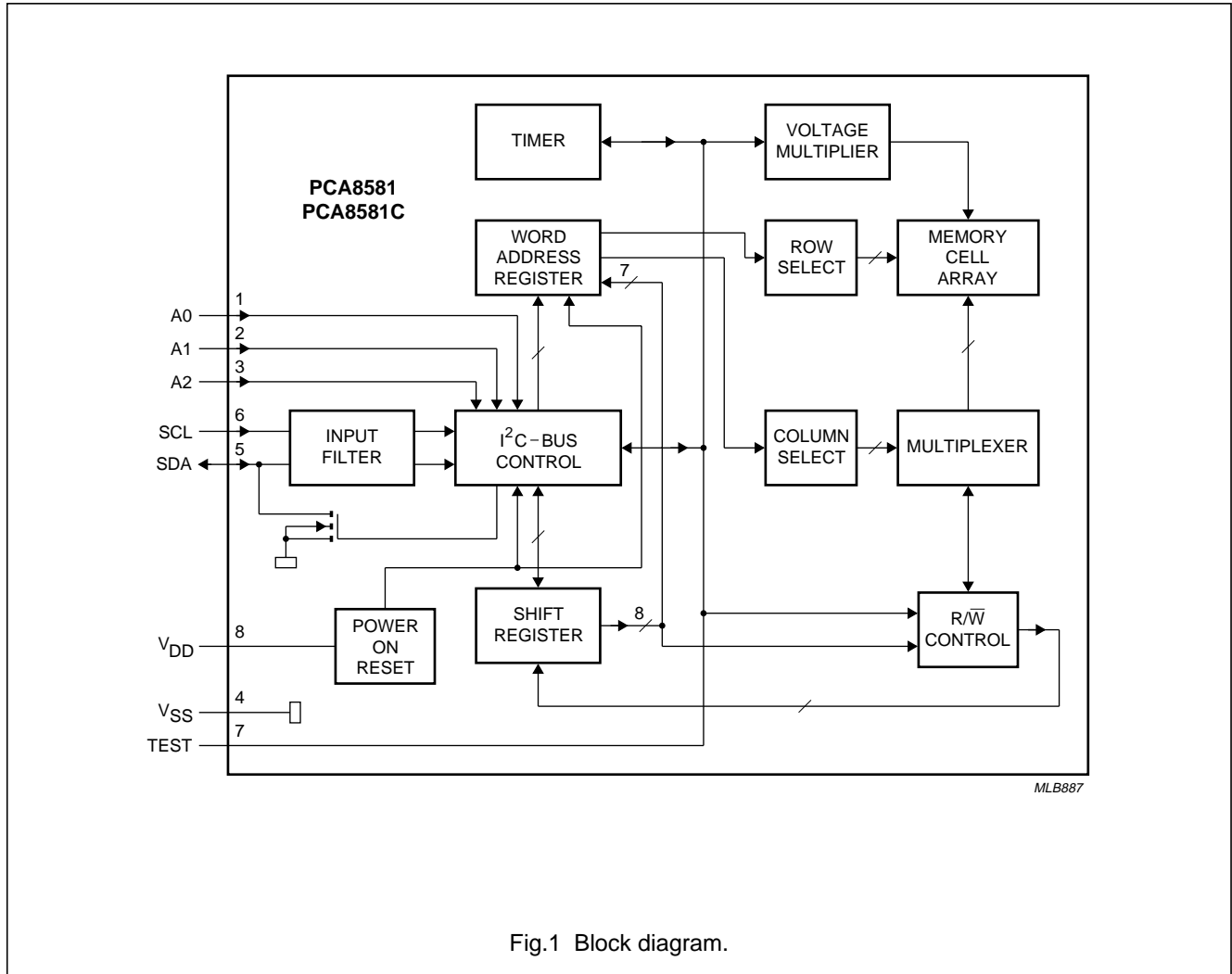

Fig.1 Block diagram.

6 PINNING

SYMBOL	PIN	DESCRIPTION
A0	1	hardware address input 0
A1	2	hardware address input 1
A2	3	hardware address input 2
V <sub>SS</sub>	4	negative supply
SDA	5	serial data input/output
SCL	6	serial clock input
TEST	7	test output can be connected to V <sub>SS</sub> , V <sub>DD</sub> or left open-circuit
V <sub>DD</sub>	8	positive supply

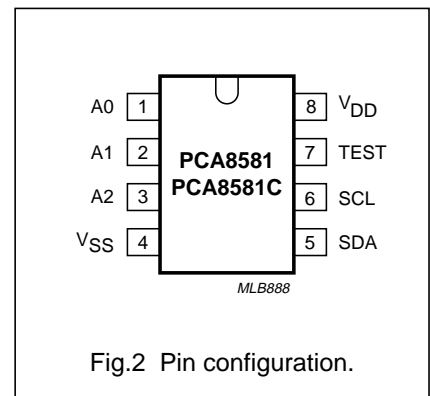

Fig.2 Pin configuration.

128 × 8-bit EEPROM with I<sup>2</sup>C-bus interface

PCA8581; PCA8581C

7 CHARACTERISTICS OF THE I<sup>2</sup>C-BUS

The I<sup>2</sup>C-bus is for bidirectional, two-line communication between different ICs or modules. The two lines are a serial data line (SDA) and a serial clock line (SCL). Both lines must be connected to a positive supply via a pull-up resistor. Data transfer may be initiated only when the bus is not busy.

7.1 Bit transfer

One data bit is transferred during each clock pulse. The data on the SDA line must remain stable during the HIGH period of the clock pulse as changes in the data line at this time will be interpreted as a control signal.

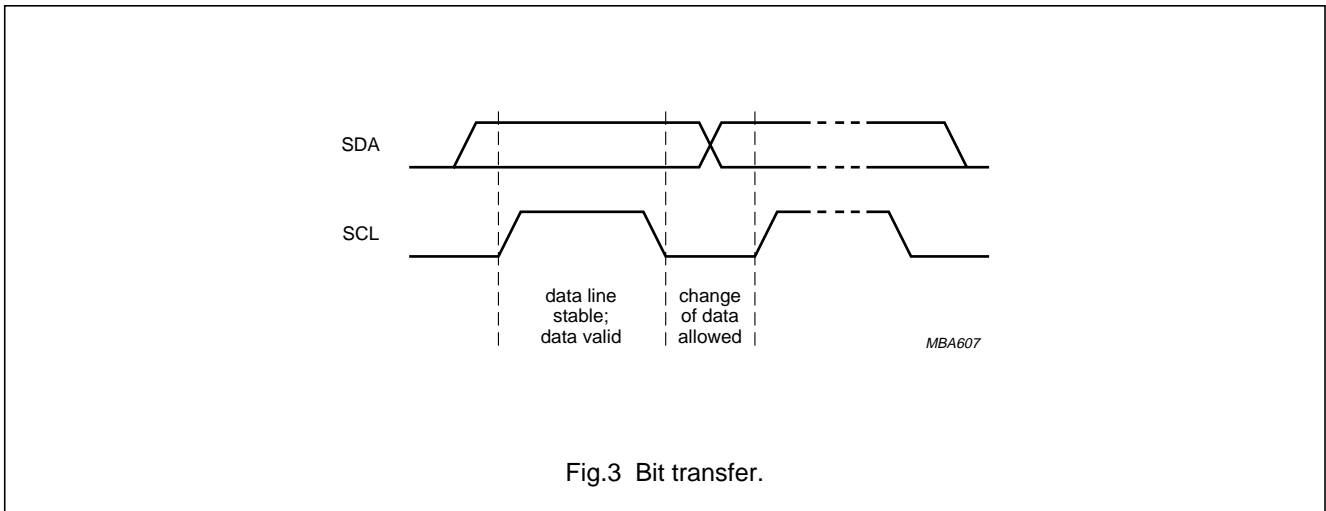

Fig.3 Bit transfer.

7.2 Start and stop conditions

Both data and clock lines remain HIGH when the bus is not busy. A HIGH-to-LOW transition of the data line, while the clock is HIGH is defined as the start condition (S). A LOW-to-HIGH transition of the data line while the clock is HIGH is defined as the stop condition (P).

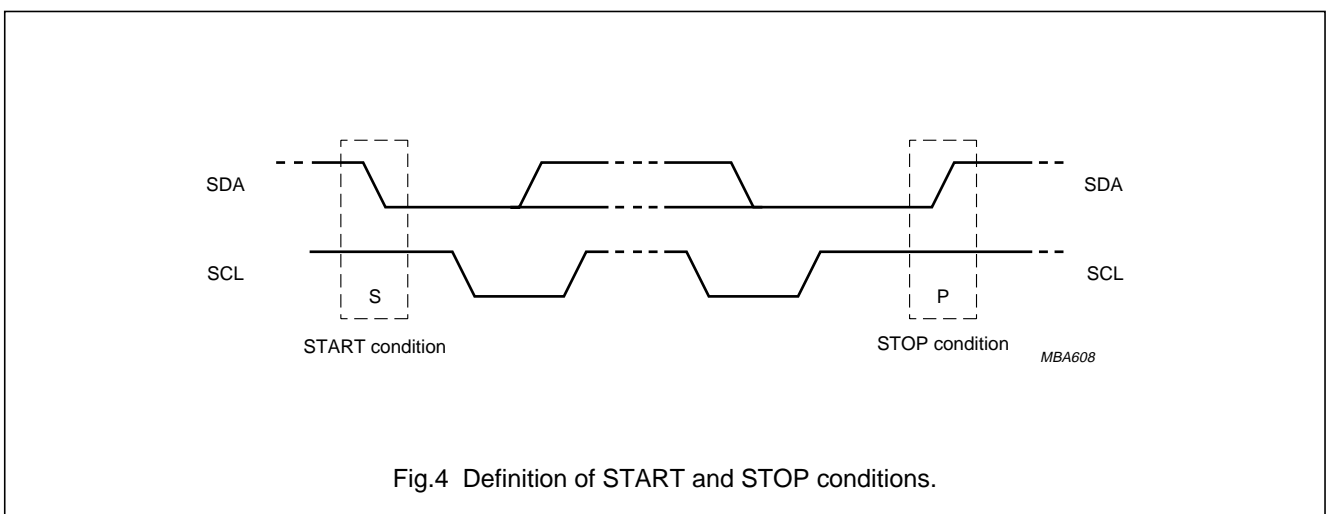

Fig.4 Definition of START and STOP conditions.

# 128 × 8-bit EEPROM with I<sup>2</sup>C-bus interface

# PCA8581; PCA8581C

### 7.3 System configuration

A device generating a message is a 'transmitter', a device receiving a message is the 'receiver'. The device that controls the message is the 'master' and the devices which are controlled by the master are the 'slaves'.

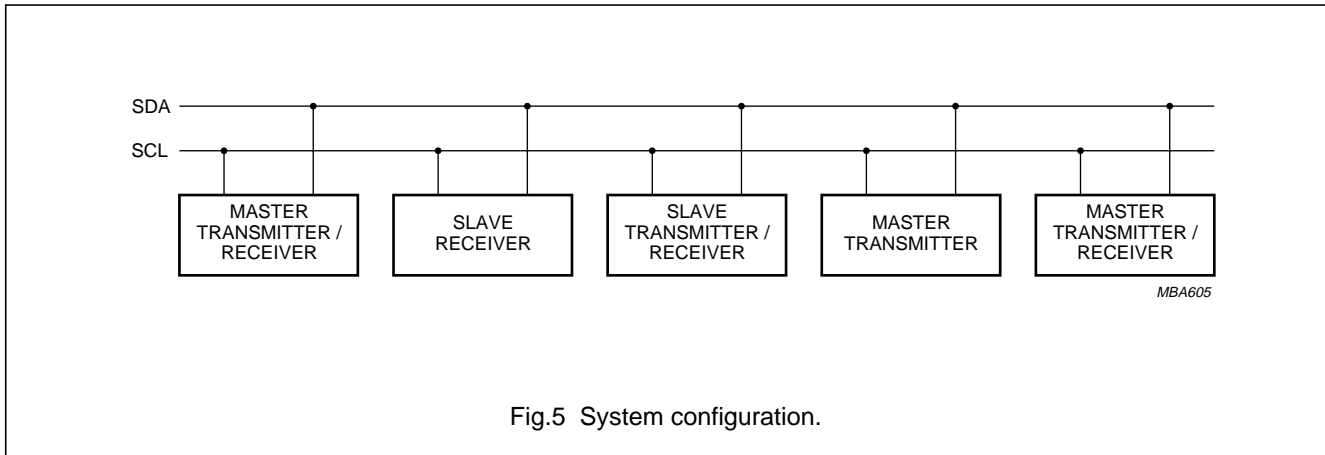

### 7.4 Acknowledge

The number of data bytes transferred between the start and stop conditions from transmitter to receiver is unlimited. Each byte of eight bits is followed by an acknowledge bit. The acknowledge bit is a HIGH level signal put on the bus by the transmitter during which time the master generates an extra acknowledge related clock pulse. A slave receiver which is addressed must generate an acknowledge after the reception of each byte. Also a master receiver must generate an acknowledge after the reception of each byte that has been clocked out of the slave transmitter.

The device that acknowledges must pull down the SDA line during the acknowledge clock pulse, so that the SDA line is stable LOW during the HIGH period of the acknowledge related clock pulse (set-up and hold times must be taken into consideration). A master receiver must signal an end of data to the transmitter by not generating an acknowledge on the last byte that has been clocked out of the slave. In this event the transmitter must leave the data line HIGH to enable the master to generate a stop condition.

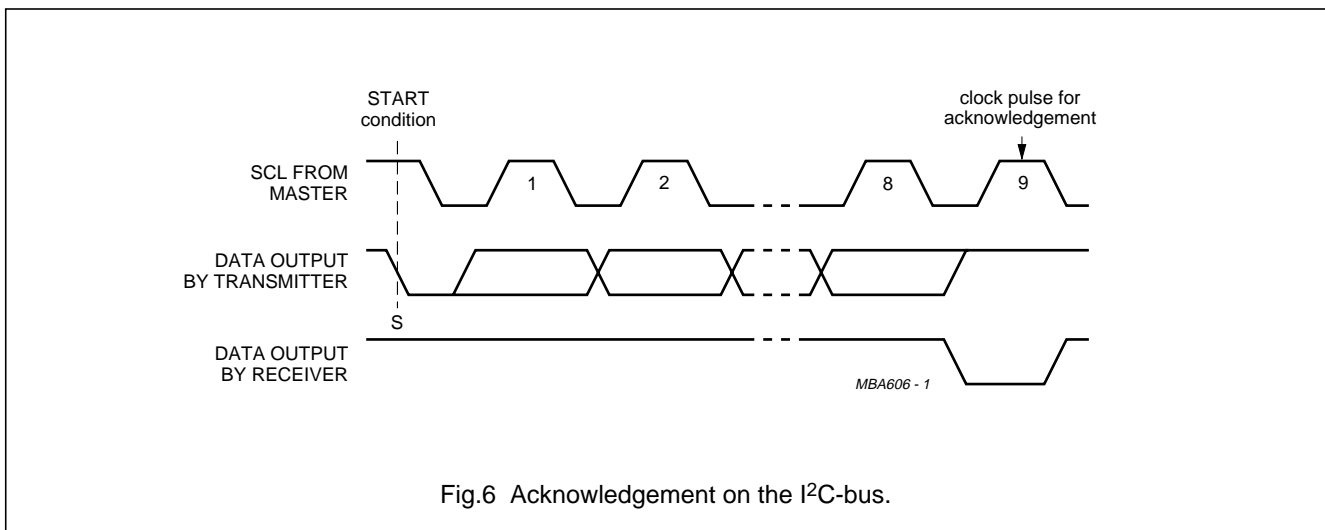

128 × 8-bit EEPROM with I<sup>2</sup>C-bus interface

PCA8581; PCA8581C

7.5 I<sup>2</sup>C-bus protocol

Before any data is transmitted on the I<sup>2</sup>C-bus, the device which should respond is addressed first. The addressing is always carried out with the first byte transmitted after the start procedure. The I<sup>2</sup>C-bus configuration for the different PCA8581 WRITE and READ cycles is shown in Figs 7, 9 and 10.

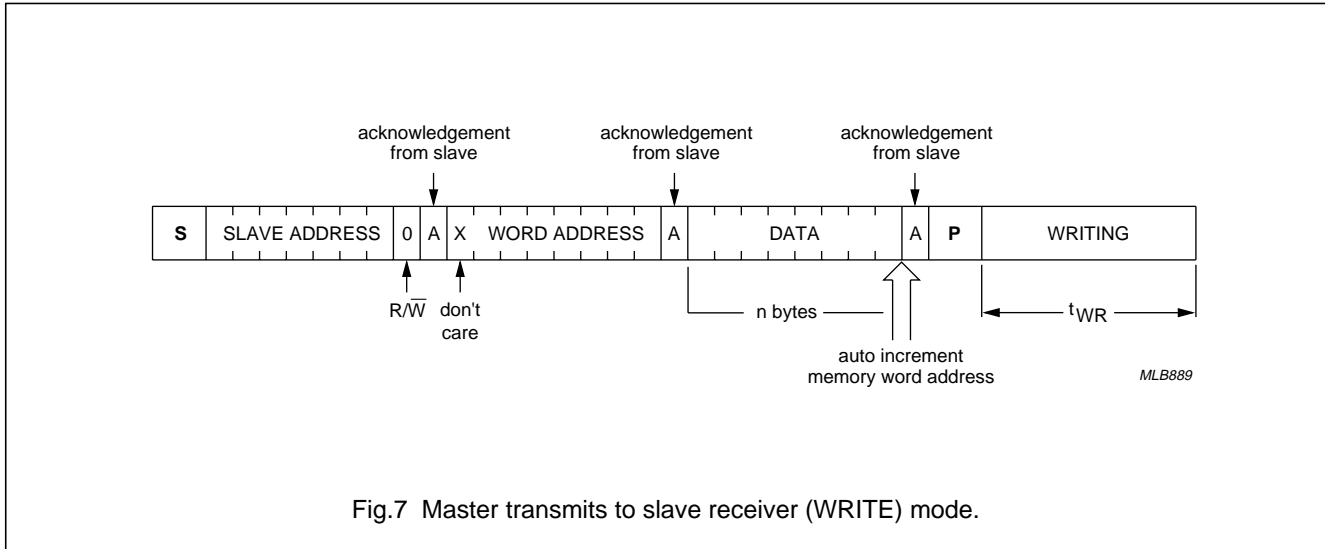

After the word address, one-to-eight data bytes can be sent. The address is automatically incremented, but the four highest address bits (row) are internally latched. Therefore all bytes are written in the same row.

An example of writing eight bytes with word address X 0 0 0 0 0 0 0 and six bytes with word address X 0 0 1 0 1 0 1 is shown in Fig.8.

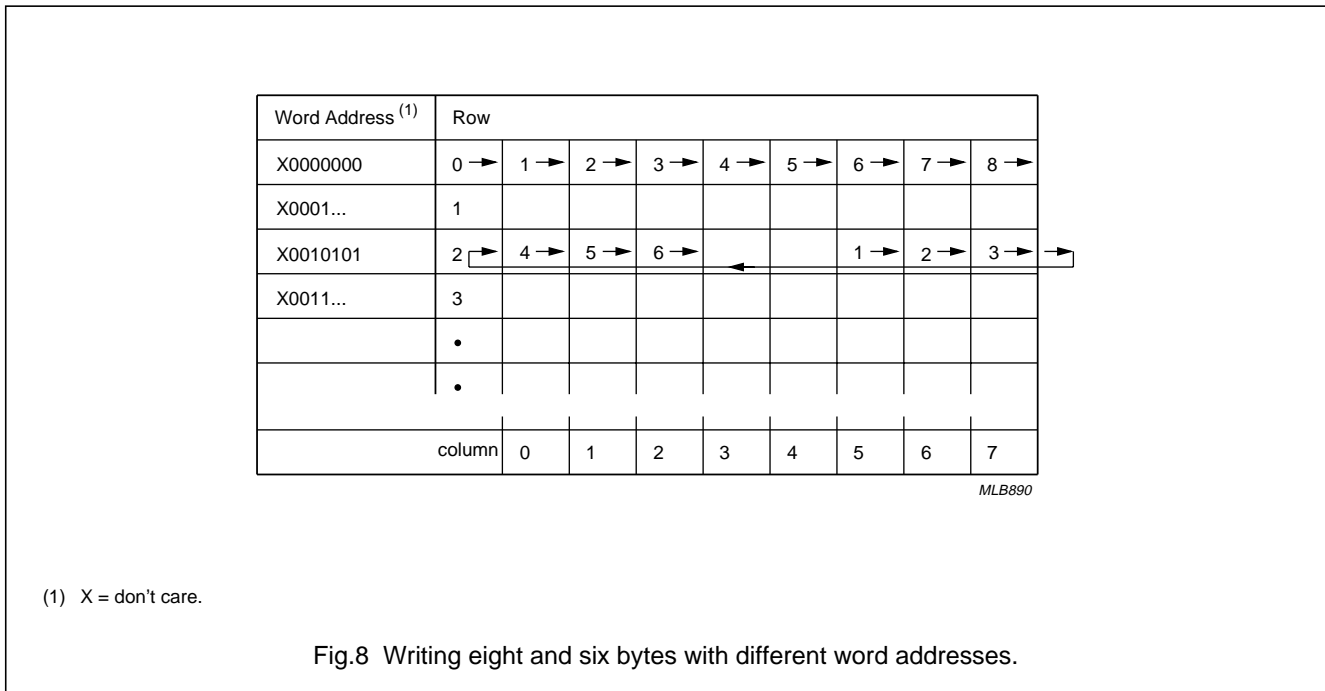

128 × 8-bit EEPROM with I<sup>2</sup>C-bus interface

PCA8581; PCA8581C

To transmit eight bytes in sequential order, begin with the lowest address bits 0 0 0. The data is written after a stop is detected. The data is only written if complete bytes have been received and acknowledged. Writing takes a time  $t_{WR}$  (6 to 10 ms) during which the device will not respond to its slave address. Note that to write the next row, a new write operation is required (start, slave address, row address, data and stop).

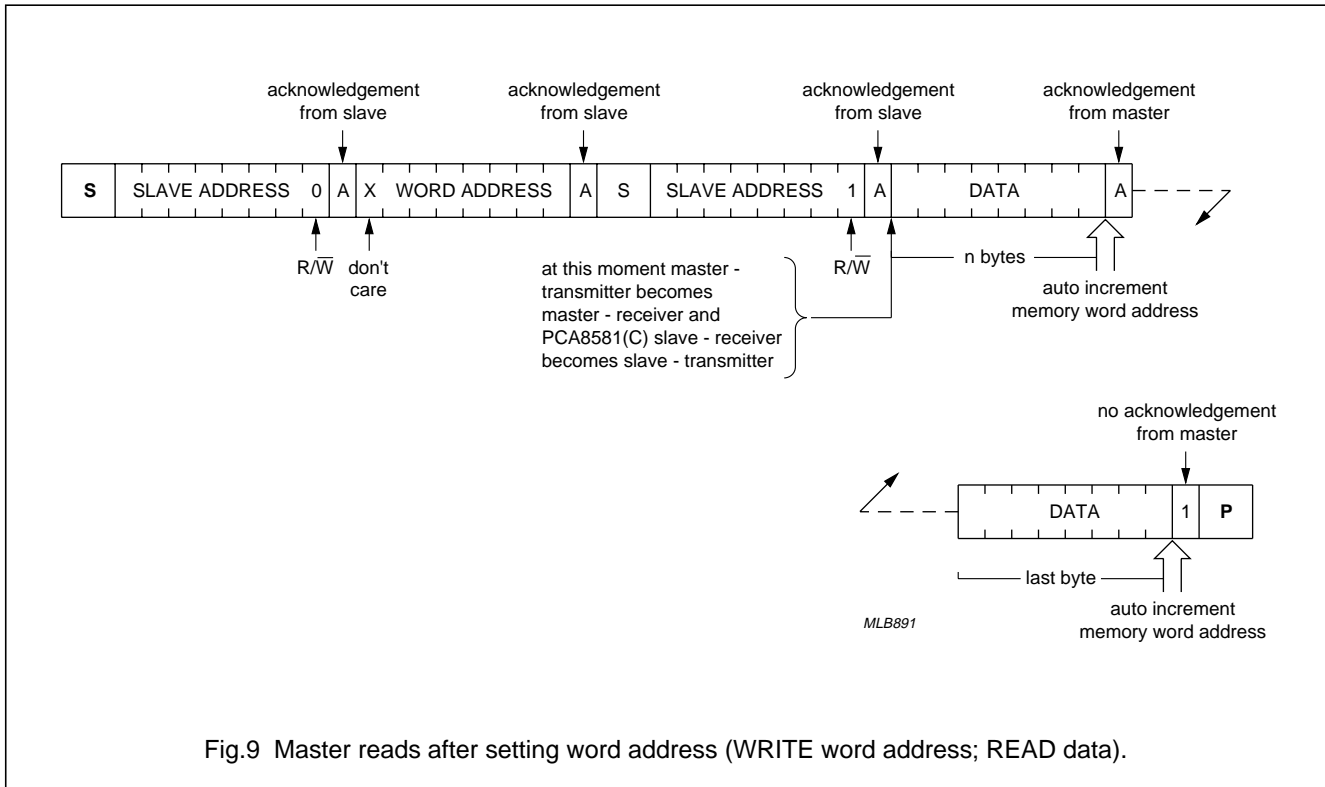

Fig.9 Master reads after setting word address (WRITE word address; READ data).

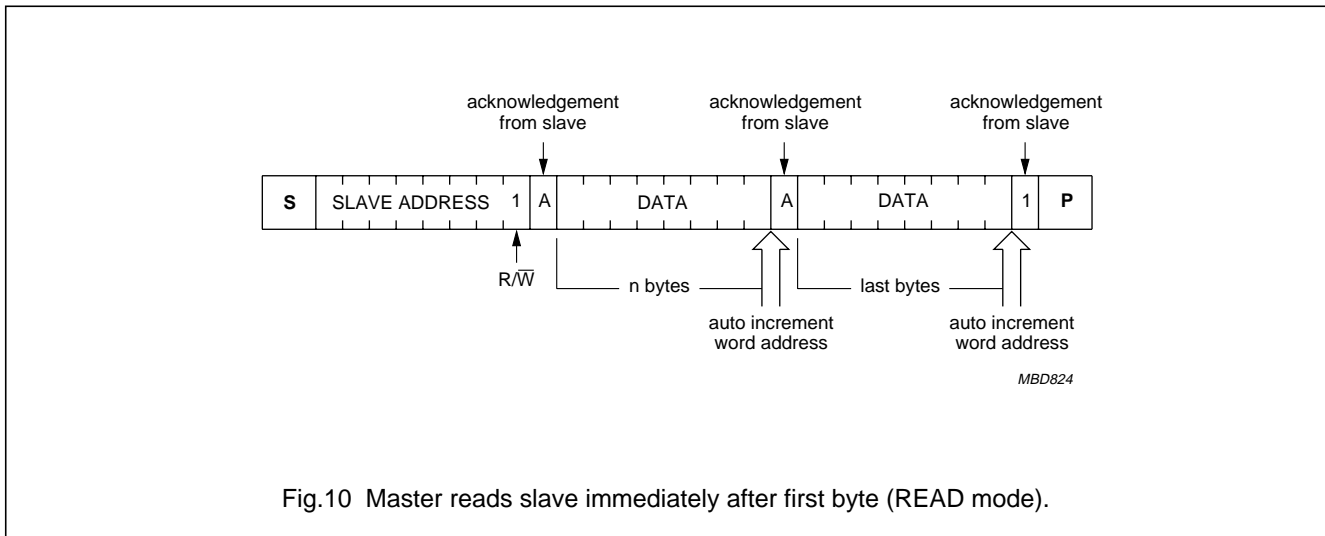

Fig.10 Master reads slave immediately after first byte (READ mode).

An unlimited number of data bytes can be read in one operation. The address is automatically incremented. If a read without setting the word address is performed after a write operation, the address pointer may point at a byte in the row after the previously written row. This occurs if, during writing, the three lowest address bits (column) rolled over.

128 × 8-bit EEPROM with I<sup>2</sup>C-bus interface

## PCA8581; PCA8581C

**8 LIMITING VALUES**

In accordance with the Absolute Maximum Rating System (IEC 134).

SYMBOL	PARAMETER	CONDITIONS	MIN.	MAX.	UNIT
V <sub>DD</sub>	supply voltage (pin 8)		-0.3	+7.0	V
V <sub>I</sub>	input voltage (any input)	measured via a 500 Ω resistor	-0.8	V <sub>DD</sub> + 0.8	V
I <sub>I</sub>	DC input current		-	±10	mA
I <sub>O</sub>	DC output current		-	±10	mA
P <sub>tot</sub>	total power dissipation per package		-	150	mW
P <sub>O</sub>	power dissipation per output		-	50	mW
T <sub>amb</sub>	operating ambient temperature		-25	+85	°C
T <sub>stg</sub>	storage temperature	without EEPROM retention	-65	+150	°C
		with EEPROM retention	-65	+85	°C

**9 HANDLING**

Inputs and outputs are protected against electrostatic discharge in normal handling. However, to be totally safe, it is desirable to take precautions appropriate to handling MOS devices. Advice can be found in Data Handbook IC12 under "Handling MOS Devices".

128 × 8-bit EEPROM with I<sup>2</sup>C-bus interface

## PCA8581; PCA8581C

**10 DC CHARACTERISTICS**

$V_{DD} = 2.5$  to  $6.0$  V (PCA8581C);  $V_{DD} = 4.5$  to  $5.5$  V (PCA8581);  $V_{SS} = 0$  V;  $T_{amb} = -25$  to  $+85$  °C; note 1; unless otherwise specified.

SYMBOL	PARAMETER	CONDITIONS	MIN.	TYP.	MAX.	UNIT
<b>Supply</b>						
$V_{DD}$	supply voltage					
	PCA8581C		2.5	–	6.0	V
	PCA8581		4.5	–	5.5	V
$I_{DD}$	supply current					
	standby mode	$f_{SCL} = 0$ Hz; $V_{IL} = 0$ V; $V_{IH} = V_{DD}$	–	–	10	μA
	during read cycle	$f_{SCL} = 100$ Hz; $V_{IL} = 0$ V; $V_{IH} = V_{DD}$	–	–	400	μA
	during write cycle	$V_{IL} = 0$ V; $V_{IH} = V_{DD}$	–	–	1000	μA
<b>Inputs A0, A1, A2, SDA and SCL</b>						
$V_{IL}$	LOW level input voltage		–	–	$0.3V_{DD}$	V
$V_{IH}$	HIGH level input voltage		$0.7V_{DD}$	–	–	V
$I_{LI}$	input leakage current	$V_I = V_{DD}$ or $V_{SS}$	–	–	1	μA
$C_i$	input capacitance	$V_I = V_{SS}$	–	–	7	pF
<b>Output SDA</b>						
$I_{OL}$	LOW level output current	$V_{OL} = 0.4$ V	3	–	–	mA
<b>Erase/write data</b>						
$t_{WR}$	write time		–	7	10	ms
$t_{RET}$	data retention time		10	–	–	years

**Note**

1. The PCA8581C is guaranteed to be programmed with all locations 'FF' (hexadecimal) provided the device has been stored within the temperature limits  $-65$  to  $+85$  °C.

128 × 8-bit EEPROM with I<sup>2</sup>C-bus interface

PCA8581; PCA8581C

11 AC CHARACTERISTICS

All timing values are valid within the operating supply voltage and ambient temperature range and reference to V<sub>IL</sub> and V<sub>IH</sub> with an input voltage swing of V<sub>SS</sub> to V<sub>DD</sub>.

SYMBOL	PARAMETER	MIN.	TYP.	MAX.	UNIT
<b>I<sup>2</sup>C-bus timing</b> (see Fig.11; note 1)					
f <sub>SCL</sub>	SCL clock frequency	–	–	100	kHz
t <sub>SP</sub>	tolerable spike width on bus	–	–	100	ns
t <sub>BUF</sub>	bus free time	4.7	–	–	μs
t <sub>SU;STA</sub>	START condition set-up time	4.7	–	–	μs
t <sub>HD;STA</sub>	START condition hold time	4.0	–	–	μs
t <sub>LOW</sub>	SCL LOW time	4.7	–	–	μs
t <sub>HIGH</sub>	SCL HIGH time	4.0	–	–	μs
t <sub>r</sub>	SCL and SDA rise time	–	–	1.0	μs
t <sub>f</sub>	SCL and SDA fall time	–	–	0.3	μs
t <sub>SU;DAT</sub>	data set-up time	250	–	–	ns
t <sub>HD;DAT</sub>	data hold time	0	–	–	ns
t <sub>VD;DAT</sub>	SCL LOW to data out valid	–	–	3.4	μs
t <sub>SU;STO</sub>	STOP condition set-up time	4.0	–	–	μs

Note

1. A detailed description of the I<sup>2</sup>C-bus specification, with applications, is given in brochure “The I<sup>2</sup>C-bus and how to use it”. This brochure may be ordered using the code 9398 393 40011.

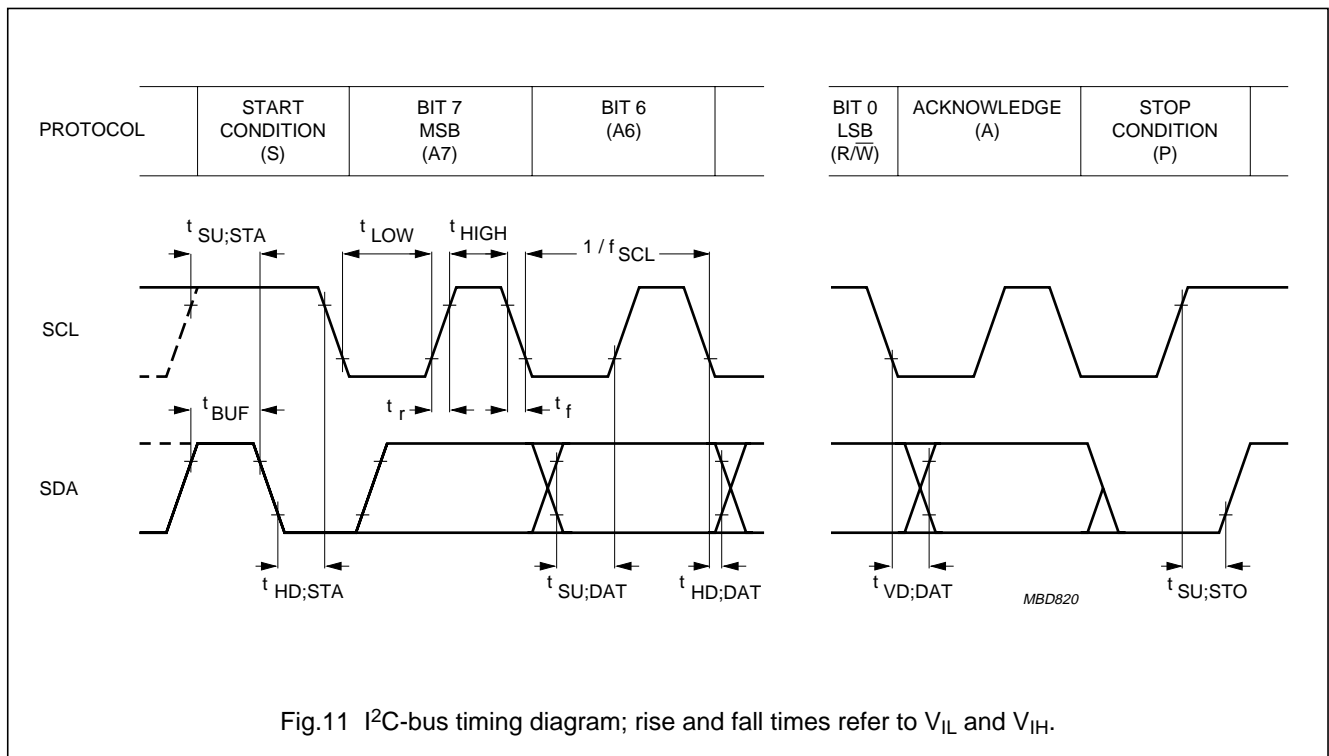

128 × 8-bit EEPROM with I<sup>2</sup>C-bus interface

PCA8581; PCA8581C

12 APPLICATION INFORMATION

12.1 Application example

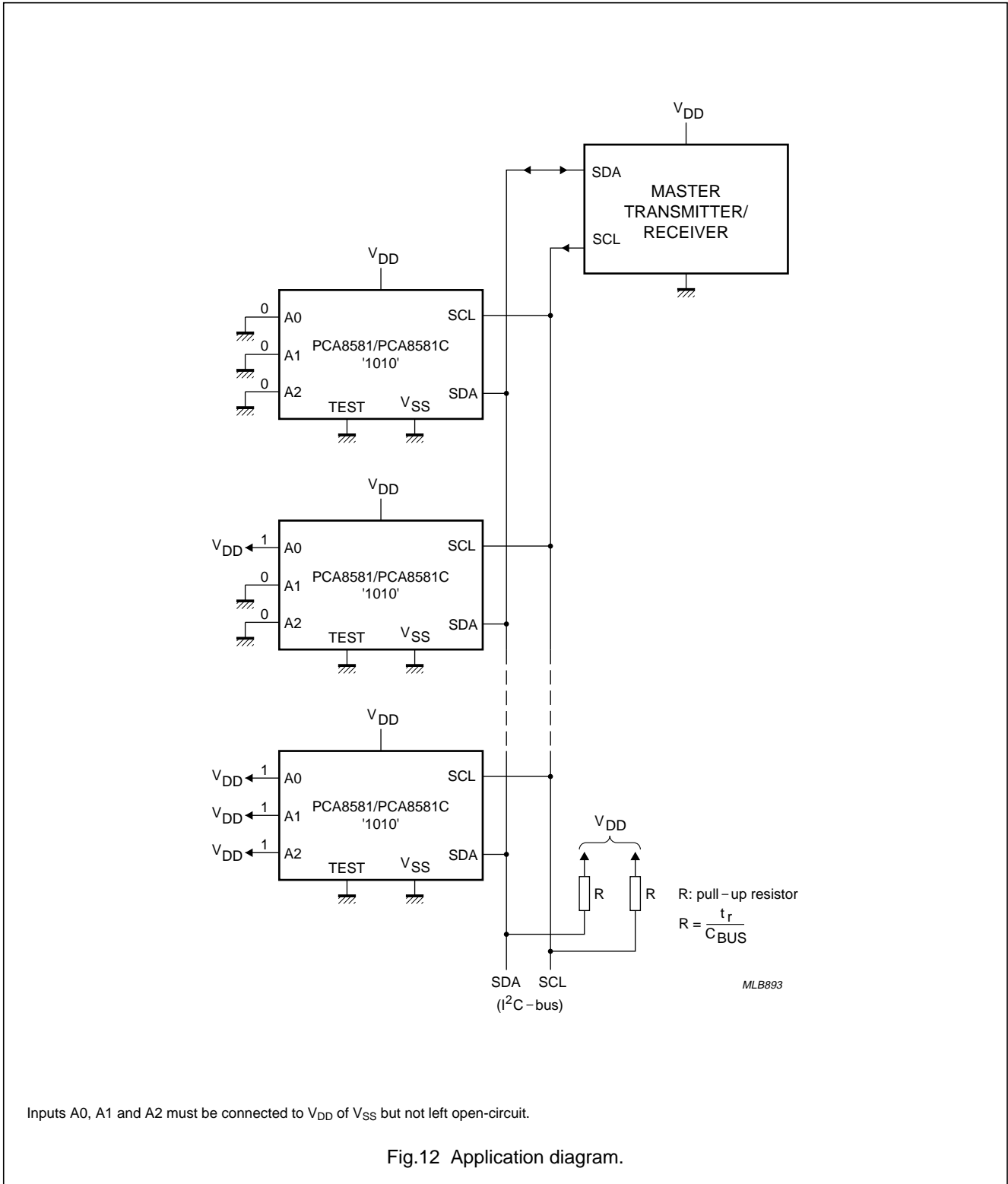

128 × 8-bit EEPROM with I<sup>2</sup>C-bus interface

PCA8581; PCA8581C

12.2 Slave address

The PCA8581 has a fixed combination 1 0 1 0 as group 1, while group 2 is fully programmable (see Fig.13).

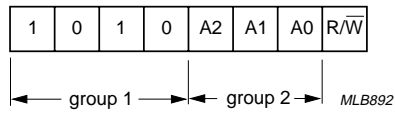
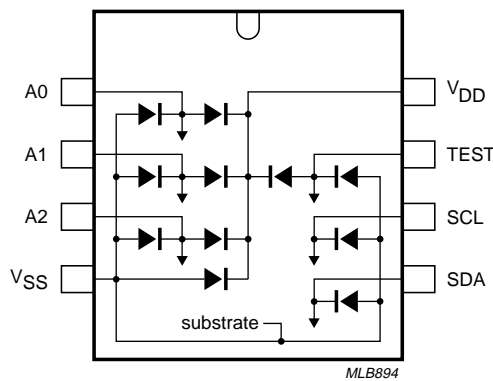

Fig.13 Slave address.

12.3 Diode protection



There is no connection between SCL and V<sub>DD</sub>, and SDA and V<sub>DD</sub>; this allows powering down the device without affecting I<sup>2</sup>C-bus operation.

Fig.14 Device diode protection.

128 × 8-bit EEPROM with I<sup>2</sup>C-bus interface

PCA8581; PCA8581C

13 PACKAGE OUTLINES

DIP8: plastic dual in-line package; 8 leads (300 mil)

SOT97-1

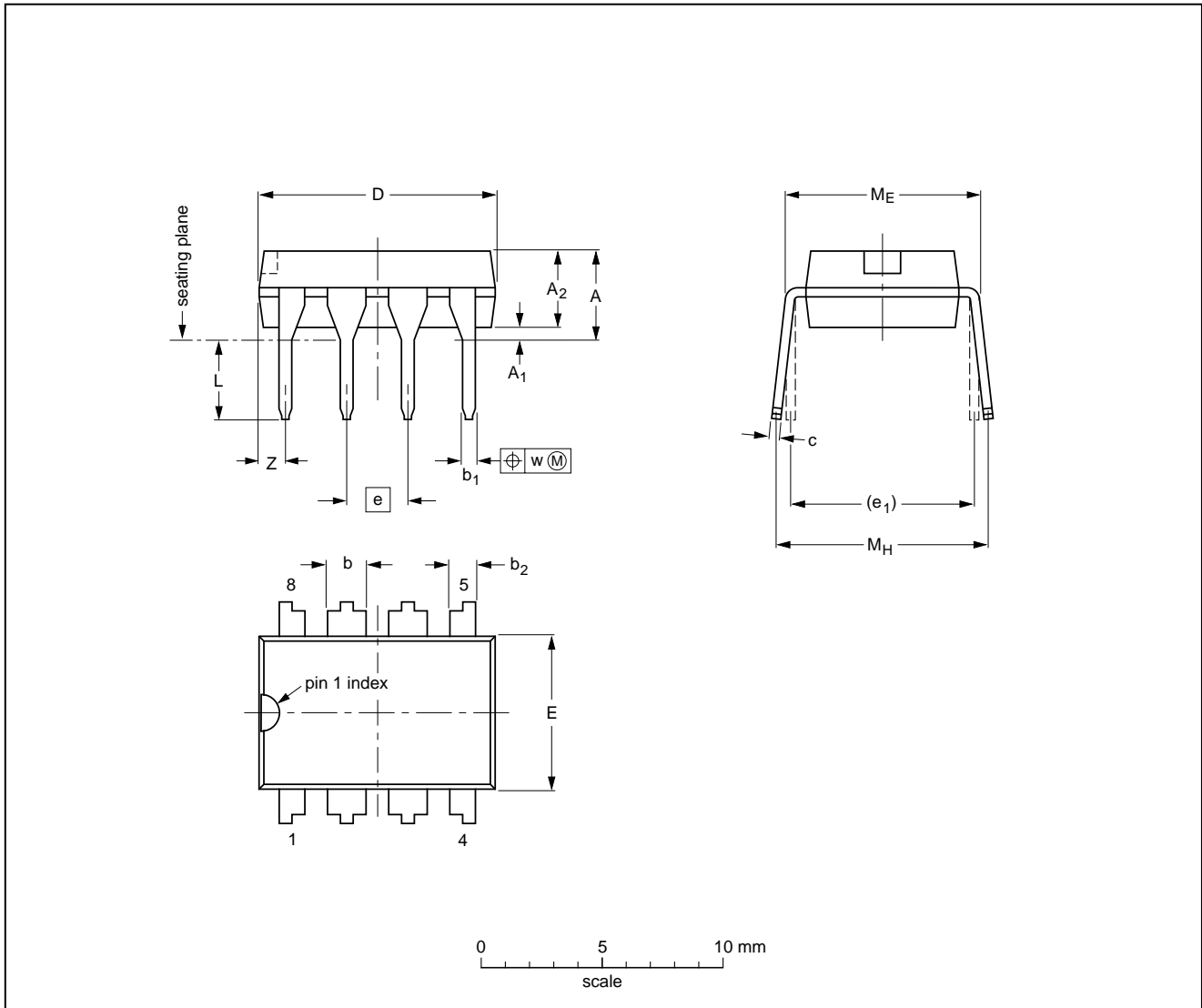

DIMENSIONS (inch dimensions are derived from the original mm dimensions)

UNIT	A max.	A <sub>1</sub> min.	A <sub>2</sub> max.	b	b <sub>1</sub>	b <sub>2</sub>	c	D <sup>(1)</sup>	E <sup>(1)</sup>	e	e <sub>1</sub>	L	M <sub>E</sub>	M <sub>H</sub>	w	Z <sup>(1)</sup> max.
mm	4.2	0.51	3.2	1.73 1.14	0.53 0.38	1.07 0.89	0.36 0.23	9.8 9.2	6.48 6.20	2.54	7.62	3.60 3.05	8.25 7.80	10.0 8.3	0.254	1.15
inches	0.17	0.020	0.13	0.068 0.045	0.021 0.015	0.042 0.035	0.014 0.009	0.39 0.36	0.26 0.24	0.10	0.30	0.14 0.12	0.32 0.31	0.39 0.33	0.01	0.045

Note

1. Plastic or metal protrusions of 0.25 mm maximum per side are not included.

OUTLINE VERSION	REFERENCES				EUROPEAN PROJECTION	ISSUE DATE
	IEC	JEDEC	EIAJ			
SOT97-1	050G01	MO-001AN				92-11-17 95-02-04

128 × 8-bit EEPROM with I<sup>2</sup>C-bus interface

PCA8581; PCA8581C

S08: plastic small outline package; 8 leads; body width 3.9 mm

SOT96-1

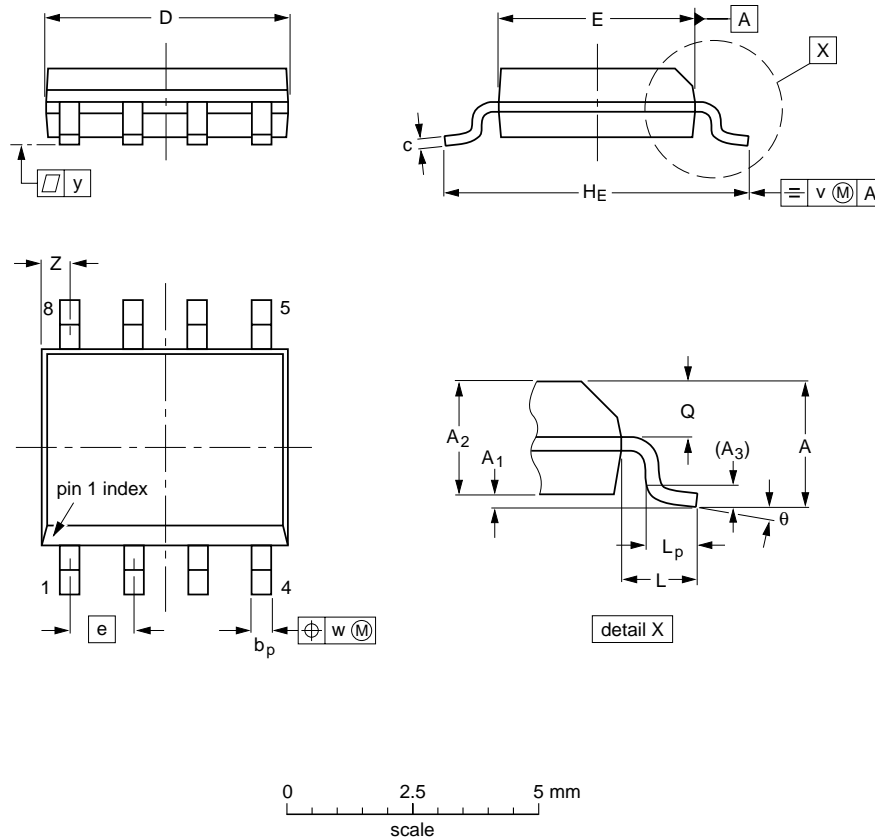

**DIMENSIONS (inch dimensions are derived from the original mm dimensions)**

UNIT	A max.	A <sub>1</sub>	A <sub>2</sub>	A <sub>3</sub>	b <sub>p</sub>	c	D <sup>(1)</sup>	E <sup>(2)</sup>	e	H <sub>E</sub>	L	L <sub>p</sub>	Q	v	w	y	Z <sup>(1)</sup>	θ
mm	1.75	0.25 0.10	1.45 1.25	0.25	0.49 0.36	0.25 0.19	5.0 4.8	4.0 3.8	1.27	6.2 5.8	1.05	1.0 0.4	0.7 0.6	0.25	0.25	0.1	0.7 0.3	8° 0°
inches	0.069	0.010 0.004	0.057 0.049	0.01	0.019 0.014	0.0100 0.0075	0.20 0.19	0.16 0.15	0.050	0.244 0.228	0.041	0.039 0.016	0.028 0.024	0.01	0.01	0.004	0.028 0.012	

**Notes**

1. Plastic or metal protrusions of 0.15 mm maximum per side are not included.
2. Plastic or metal protrusions of 0.25 mm maximum per side are not included.

OUTLINE VERSION	REFERENCES			EUROPEAN PROJECTION	ISSUE DATE
	IEC	JEDEC	EIAJ		
SOT96-1	076E03S	MS-012AA			95-02-04 97-05-22

## 128 × 8-bit EEPROM with I<sup>2</sup>C-bus interface

PCA8581; PCA8581C

### 14 SOLDERING

#### 14.1 Introduction

There is no soldering method that is ideal for all IC packages. Wave soldering is often preferred when through-hole and surface mounted components are mixed on one printed-circuit board. However, wave soldering is not always suitable for surface mounted ICs, or for printed-circuits with high population densities. In these situations reflow soldering is often used.

This text gives a very brief insight to a complex technology. A more in-depth account of soldering ICs can be found in our *"IC Package Databook"* (order code 9398 652 90011).

#### 14.2 DIP

##### 14.2.1 SOLDERING BY DIPPING OR BY WAVE

The maximum permissible temperature of the solder is 260 °C; solder at this temperature must not be in contact with the joint for more than 5 seconds. The total contact time of successive solder waves must not exceed 5 seconds.

The device may be mounted up to the seating plane, but the temperature of the plastic body must not exceed the specified maximum storage temperature ( $T_{stg\ max}$ ). If the printed-circuit board has been pre-heated, forced cooling may be necessary immediately after soldering to keep the temperature within the permissible limit.

##### 14.2.2 REPAIRING SOLDERED JOINTS

Apply a low voltage soldering iron (less than 24 V) to the lead(s) of the package, below the seating plane or not more than 2 mm above it. If the temperature of the soldering iron bit is less than 300 °C it may remain in contact for up to 10 seconds. If the bit temperature is between 300 and 400 °C, contact may be up to 5 seconds.

#### 14.3 SO

##### 14.3.1 REFLOW SOLDERING

Reflow soldering techniques are suitable for all SO packages.

Reflow soldering requires solder paste (a suspension of fine solder particles, flux and binding agent) to be applied to the printed-circuit board by screen printing, stencilling or pressure-syringe dispensing before package placement.

Several techniques exist for reflowing; for example, thermal conduction by heated belt. Dwell times vary between 50 and 300 seconds depending on heating method. Typical reflow temperatures range from 215 to 250 °C.

Preheating is necessary to dry the paste and evaporate the binding agent. Preheating duration: 45 minutes at 45 °C.

##### 14.3.2 WAVE SOLDERING

Wave soldering techniques can be used for all SO packages if the following conditions are observed:

- A double-wave (a turbulent wave with high upward pressure followed by a smooth laminar wave) soldering technique should be used.
- The longitudinal axis of the package footprint must be parallel to the solder flow.
- The package footprint must incorporate solder thieves at the downstream end.

During placement and before soldering, the package must be fixed with a droplet of adhesive. The adhesive can be applied by screen printing, pin transfer or syringe dispensing. The package can be soldered after the adhesive is cured.

Maximum permissible solder temperature is 260 °C, and maximum duration of package immersion in solder is 10 seconds, if cooled to less than 150 °C within 6 seconds. Typical dwell time is 4 seconds at 250 °C.

A mildly-activated flux will eliminate the need for removal of corrosive residues in most applications.

##### 14.3.3 REPAIRING SOLDERED JOINTS

Fix the component by first soldering two diagonally-opposite end leads. Use only a low voltage soldering iron (less than 24 V) applied to the flat part of the lead. Contact time must be limited to 10 seconds at up to 300 °C. When using a dedicated tool, all other leads can be soldered in one operation within 2 to 5 seconds between 270 and 320 °C.

128 × 8-bit EEPROM with I<sup>2</sup>C-bus interface

## PCA8581; PCA8581C

**15 DEFINITIONS**

<b>Data sheet status</b>	
Objective specification	This data sheet contains target or goal specifications for product development.
Preliminary specification	This data sheet contains preliminary data; supplementary data may be published later.
Product specification	This data sheet contains final product specifications.
<b>Limiting values</b>	
Limiting values given are in accordance with the Absolute Maximum Rating System (IEC 134). Stress above one or more of the limiting values may cause permanent damage to the device. These are stress ratings only and operation of the device at these or at any other conditions above those given in the Characteristics sections of the specification is not implied. Exposure to limiting values for extended periods may affect device reliability.	
<b>Application information</b>	
Where application information is given, it is advisory and does not form part of the specification.	

**16 LIFE SUPPORT APPLICATIONS**

These products are not designed for use in life support appliances, devices, or systems where malfunction of these products can reasonably be expected to result in personal injury. Philips customers using or selling these products for use in such applications do so at their own risk and agree to fully indemnify Philips for any damages resulting from such improper use or sale.

**17 PURCHASE OF PHILIPS I<sup>2</sup>C COMPONENTS**

Purchase of Philips I<sup>2</sup>C components conveys a license under the Philips' I<sup>2</sup>C patent to use the components in the I<sup>2</sup>C system provided the system conforms to the I<sup>2</sup>C specification defined by Philips. This specification can be ordered using the code 9398 393 40011.

128 × 8-bit EEPROM with I<sup>2</sup>C-bus interface

PCA8581; PCA8581C

---

**NOTES**

128 × 8-bit EEPROM with I<sup>2</sup>C-bus interface

PCA8581; PCA8581C

---

**NOTES**

# Philips Semiconductors – a worldwide company

**Argentina:** see South America

**Australia:** 34 Waterloo Road, NORTH RYDE, NSW 2113,  
Tel. +61 2 9805 4455, Fax. +61 2 9805 4466

**Austria:** Computerstr. 6, A-1101 WIEN, P.O. Box 213,  
Tel. +43 1 60 101, Fax. +43 1 60 101 1210

**Belarus:** Hotel Minsk Business Center, Bld. 3, r. 1211, Volodarski Str. 6,  
220050 MINSK, Tel. +375 172 200 733, Fax. +375 172 200 773

**Belgium:** see The Netherlands

**Brazil:** see South America

**Bulgaria:** Philips Bulgaria Ltd., Energoproject, 15th floor,  
51 James Bourchier Blvd., 1407 SOFIA,  
Tel. +359 2 689 211, Fax. +359 2 689 102

**Canada:** PHILIPS SEMICONDUCTORS/COMPONENTS,  
Tel. +1 800 234 7381

**China/Hong Kong:** 501 Hong Kong Industrial Technology Centre,  
72 Tat Chee Avenue, Kowloon Tong, HONG KONG,  
Tel. +852 2319 7888, Fax. +852 2319 7700

**Colombia:** see South America

**Czech Republic:** see Austria

**Denmark:** Prags Boulevard 80, PB 1919, DK-2300 COPENHAGEN S,  
Tel. +45 32 88 2636, Fax. +45 31 57 1949

**Finland:** Sinikalliontie 3, FIN-02630 ESPOO,  
Tel. +358 9 615800, Fax. +358 9 61580/xxx

**France:** 4 Rue du Port-aux-Vins, BP317, 92156 SURESNES Cedex,  
Tel. +33 1 40 99 6161, Fax. +33 1 40 99 6427

**Germany:** Hammerbrookstraße 69, D-20097 HAMBURG,  
Tel. +49 40 23 53 60, Fax. +49 40 23 536 300

**Greece:** No. 15, 25th March Street, GR 17778 TAVROS/ATHENS,  
Tel. +30 1 4894 339/239, Fax. +30 1 4814 240

**Hungary:** see Austria

**India:** Philips INDIA Ltd, Shivsagar Estate, A Block, Dr. Annie Besant Rd.  
Worli, MUMBAI 400 018, Tel. +91 22 4938 541, Fax. +91 22 4938 722

**Indonesia:** see Singapore

**Ireland:** Newstead, Clonskeagh, DUBLIN 14,  
Tel. +353 1 7640 000, Fax. +353 1 7640 200

**Israel:** RAPAC Electronics, 7 Kehilat Saloniki St, TEL AVIV 61180,  
Tel. +972 3 645 0444, Fax. +972 3 649 1007

**Italy:** PHILIPS SEMICONDUCTORS, Piazza IV Novembre 3,  
20124 MILANO, Tel. +39 2 6752 2531, Fax. +39 2 6752 2557

**Japan:** Philips Bldg 13-37, Kohnan 2-chome, Minato-ku, TOKYO 108,  
Tel. +81 3 3740 5130, Fax. +81 3 3740 5077

**Korea:** Philips House, 260-199 Itaewon-dong, Yongsan-ku, SEOUL,  
Tel. +82 2 709 1412, Fax. +82 2 709 1415

**Malaysia:** No. 76 Jalan Universiti, 46200 PETALING JAYA, SELANGOR,  
Tel. +60 3 750 5214, Fax. +60 3 757 4880

**Mexico:** 5900 Gateway East, Suite 200, EL PASO, TEXAS 79905,  
Tel. +9-5 800 234 7381

**Middle East:** see Italy

**Netherlands:** Postbus 90050, 5600 PB EINDHOVEN, Bldg. VB,  
Tel. +31 40 27 82785, Fax. +31 40 27 88399

**New Zealand:** 2 Wagener Place, C.P.O. Box 1041, AUCKLAND,  
Tel. +64 9 849 4160, Fax. +64 9 849 7811

**Norway:** Box 1, Manglerud 0612, OSLO,  
Tel. +47 22 74 8000, Fax. +47 22 74 8341

**Philippines:** Philips Semiconductors Philippines Inc.,  
106 Valero St. Salcedo Village, P.O. Box 2108 MCC, MAKATI,  
Metro MANILA, Tel. +63 2 816 6380, Fax. +63 2 817 3474

**Poland:** Ul. Lukiska 10, PL 04-123 WARSZAWA,  
Tel. +48 22 612 2831, Fax. +48 22 612 2327

**Portugal:** see Spain

**Romania:** see Italy

**Russia:** Philips Russia, Ul. Usatcheva 35A, 119048 MOSCOW,  
Tel. +7 095 755 6918, Fax. +7 095 755 6919

**Singapore:** Lorong 1, Toa Payoh, SINGAPORE 1231,  
Tel. +65 350 2538, Fax. +65 251 6500

**Slovakia:** see Austria

**Slovenia:** see Italy

**South Africa:** S.A. PHILIPS Pty Ltd., 195-215 Main Road Martindale,  
2092 JOHANNESBURG, P.O. Box 7430 Johannesburg 2000,  
Tel. +27 11 470 5911, Fax. +27 11 470 5494

**South America:** Rua do Rocio 220, 5th floor, Suite 51,  
04552-903 São Paulo, SÃO PAULO - SP, Brazil,  
Tel. +55 11 821 2333, Fax. +55 11 829 1849

**Spain:** Balmes 22, 08007 BARCELONA,  
Tel. +34 3 301 6312, Fax. +34 3 301 4107

**Sweden:** Kottbygatan 7, Akalla, S-16485 STOCKHOLM,  
Tel. +46 8 632 2000, Fax. +46 8 632 2745

**Switzerland:** Allmendstrasse 140, CH-8027 ZÜRICH,  
Tel. +41 1 488 2686, Fax. +41 1 481 7730

**Taiwan:** Philips Semiconductors, 6F, No. 96, Chien Kuo N. Rd., Sec. 1,  
TAIPEI, Taiwan Tel. +886 2 2134 2870, Fax. +886 2 2134 2874

**Thailand:** PHILIPS ELECTRONICS (THAILAND) Ltd.,  
209/2 Sanpavuth-Bangna Road Prakanong, BANGKOK 10260,  
Tel. +66 2 745 4090, Fax. +66 2 398 0793

**Turkey:** Talatpasa Cad. No. 5, 80640 GÜLTEPE/ISTANBUL,  
Tel. +90 212 279 2770, Fax. +90 212 282 6707

**Ukraine:** PHILIPS UKRAINE, 4 Patrice Lumumba str., Building B, Floor 7,  
252042 KIEV, Tel. +380 44 264 2776, Fax. +380 44 268 0461

**United Kingdom:** Philips Semiconductors Ltd., 276 Bath Road, Hayes,  
MIDDLESEX UB3 5BX, Tel. +44 181 730 5000, Fax. +44 181 754 8421

**United States:** 811 East Arques Avenue, SUNNYVALE, CA 94088-3409,  
Tel. +1 800 234 7381

**Uruguay:** see South America

**Vietnam:** see Singapore

**Yugoslavia:** PHILIPS, Trg N. Pasica 5/v, 11000 BEOGRAD,  
Tel. +381 11 625 344, Fax. +381 11 635 777

**For all other countries apply to:** Philips Semiconductors, Marketing & Sales Communications,  
Building BE-p, P.O. Box 218, 5600 MD EINDHOVEN, The Netherlands, Fax. +31 40 27 24825

**Internet:** <http://www.semiconductors.philips.com>

© Philips Electronics N.V. 1997

SCA53

All rights are reserved. Reproduction in whole or in part is prohibited without the prior written consent of the copyright owner.

The information presented in this document does not form part of any quotation or contract, is believed to be accurate and reliable and may be changed without notice. No liability will be accepted by the publisher for any consequence of its use. Publication thereof does not convey nor imply any license under patent- or other industrial or intellectual property rights.

Printed in The Netherlands

417067/1200/03/pp20

Date of release: 1997 Apr 02

Document order number: 9397 750 01747

*Let's make things better.*

**Philips  
Semiconductors**



**PHILIPS**

## Looking for pricing, stock, or lifecycle information?

Click below to explore more details on WIN SOURCE:

- ⊖ [View PCA8581T/6,112 on WIN SOURCE](#)
- ⊖ [NXP / Nexperia Information](#)

## Optimize Your Supply Chain with WIN SOURCE Solutions

- ✓ Global Sourcing Solution
- ✓ Obsolete Management
- ✓ Cost Control Management
- ✓ Shortage Management
- ✓ Alternative Solution
- ✓ Excess Inventory Management