



**THE DATASHEET OF
PCA8565TS/1,118**





PCA8565

Real time clock/calendar

Rev. 4 — 5 December 2014

Product data sheet

1. General description

The PCA8565 is a CMOS¹ real time clock and calendar optimized for low power consumption. A programmable clock output, interrupt output and voltage-low detector are also provided. All address and data are transferred serially via a two-line bidirectional I²C-bus. Maximum bus speed is 400 kbit/s. The built-in word address register is incremented automatically after each written or read data byte.

For a selection of NXP Real-Time Clocks, see [Table 36 on page 40](#)

2. Features and benefits

- AEC-Q100 compliant (PCA8565TS) for automotive applications
- Provides year, month, day, weekday, hours, minutes and seconds based on a 32.768 kHz quartz crystal
- Clock operating voltage: 0.9 V to 5.5 V at room temperature
- Extended operating temperature range: -40 °C to +125 °C
- Low current; typical 0.65 μA at V_{DD} = 3.0 V and T_{amb} = 25 °C
- 400 kHz two-wire I²C-bus interface (at V_{DD} = 1.8 V to 5.5 V)
- Programmable clock output for peripheral devices (32.768 kHz, 1.024 kHz, 32 Hz and 1 Hz)
- Alarm and timer functions
- Internal power-on reset
- I²C-bus slave address: read A3h and write A2h
- Open-drain interrupt pin
- One integrated oscillator capacitor

3. Applications

- Automotive
- Industrial
- Other applications that require a wide operating temperature range

1. The definition of the abbreviations and acronyms used in this data sheet can be found in [Section 22](#).



4. Ordering information

Table 1. Ordering information

Type number	Package		
	Name	Description	Version
PCA8565TS	TSSOP8	plastic thin shrink small outline package; 8 leads; body width 3 mm	SOT505-1

4.1 Ordering options

Table 2. Ordering options

Product type number	Orderable part number	Sales item (12NC)	Delivery form	IC revision
PCA8565TS/1	PCA8565TS/1,118	935272132118	tape and reel, 13 inch	1
PCA8565TS/S410/1	PCA8565TS/S410/1,5	935273247518	tape and reel, 13 inch, dry pack	1

5. Marking

Table 3. Marking codes

Type number	Marking code
PCA8565TS	8565

6. Block diagram

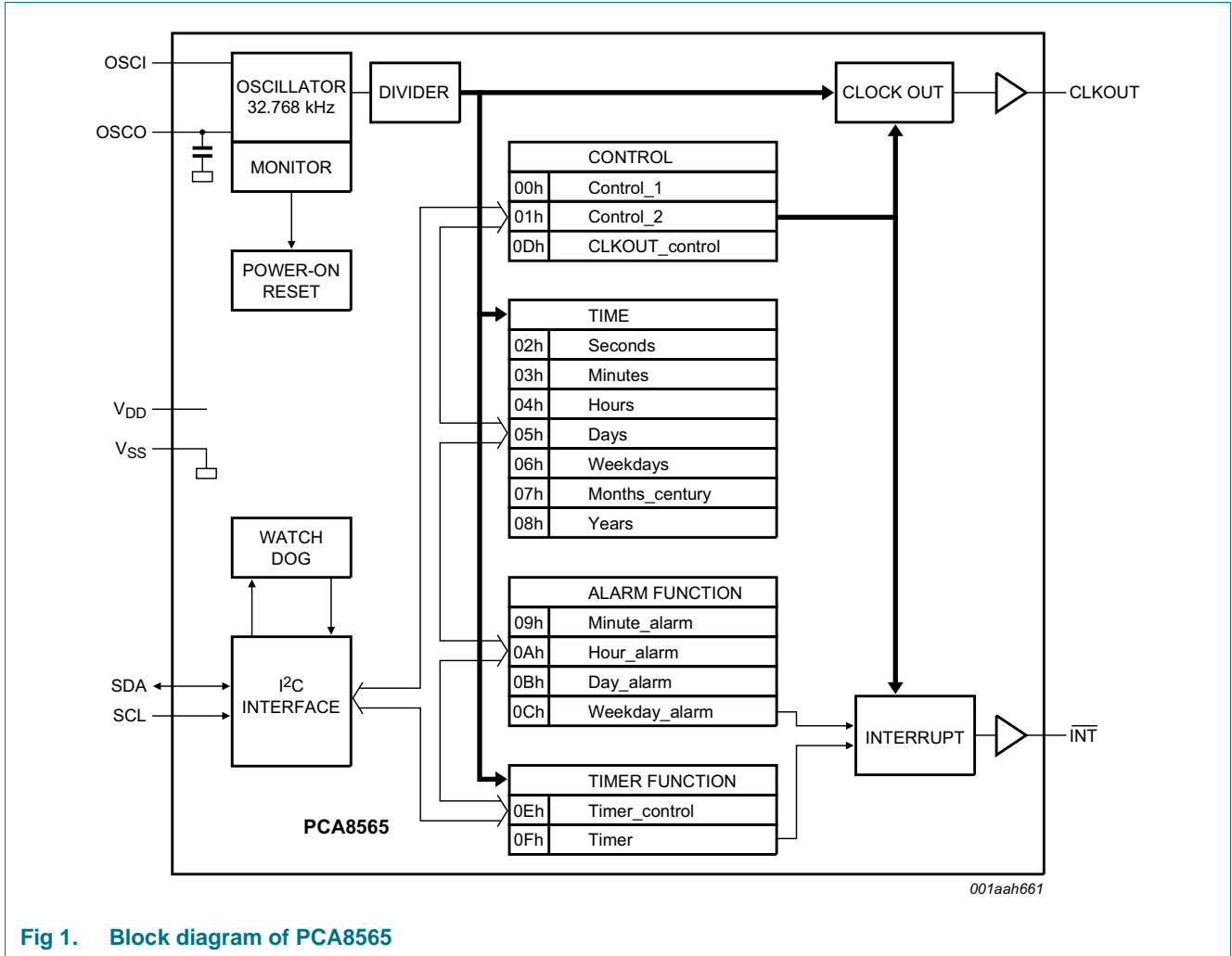
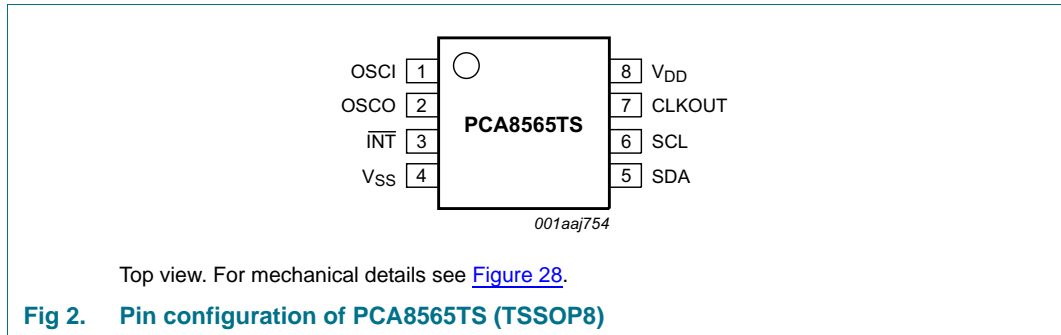

Fig 1. Block diagram of PCA8565

7. Pinning information

7.1 Pinning



7.2 Pin description

Table 4. Pin description

Input or input/output pins must always be at a defined level (V_{SS} or V_{DD}) unless otherwise specified.

Symbol	Pin	Description
	PCA8565TS	
OSCI	1	oscillator input
OSCO	2	oscillator output
$\overline{\text{INT}}$	3	interrupt output (open-drain; active LOW)
V_{SS}	4	ground
SDA	5	serial data I/O
SCL	6	serial clock input
CLKOUT	7	clock output, open-drain
V_{DD}	8	positive supply voltage

8. Functional description

The PCA8565 contains sixteen 8-bit registers with an auto-incrementing address register, an on-chip 32.768 kHz oscillator with one integrated capacitor, a frequency divider which provides the source clock for the Real Time Clock (RTC), a programmable clock output, a timer, an alarm, a voltage-low detector and a 400 kHz I²C-bus interface.

All 16 registers are designed as addressable 8-bit registers although not all bits are implemented:

- The first two registers (memory address 00h and 01h) are used as control and status registers
- The registers at memory addresses 02h through 08h are used as counters for the clock function (seconds up to years counters)
- Address locations 09h through 0Ch contain alarm registers which define the conditions for an alarm
- The register at address 0Dh controls the CLKOUT output frequency
- At address 0Eh is the timer control register and address 0Fh contains the timer value

The arrays SECONDS, MINUTES, HOURS, DAYS, WEEKDAYS, MONTHS, YEARS as well as the bit fields MINUTE_ALARM, HOUR_ALARM, DAY_ALARM and WEEKDAY_ALARM are all coded in Binary Coded Decimal (BCD) format.

When one of the RTC registers is written or read the contents of all time counters are frozen. This prevents faulty writing or reading of the clock or calendar during a carry condition (see [Section 9.5.3](#)).

8.1 Register overview

Table 5. Register overview and control bits default values

Bit positions labeled as - are not implemented. Bit positions labeled as N should always be written with logic 0. Reset values are shown in [Table 8](#).

Address	Register name	Bit							
		7	6	5	4	3	2	1	0
Control registers									
00h	Control_1	TEST1	N	STOP	N	TESTC	N	N	N
01h	Control_2	N	N	N	TI_TP	AF	TF	AIE	TIE
Time and date registers									
02h	Seconds	VL	SECONDS (0 to 59)						
03h	Minutes	-	MINUTES (0 to 59)						
04h	Hours	-	-	HOURS (0 to 23)					
05h	Days	-	-	DAYS (1 to 31)					
06h	Weekdays	-	-	-	-	-	WEEKDAYS (0 to 6)		
07h	Months_century	C	-	-	MONTHS (1 to 12)				
08h	Years	YEARS (0 to 99)							
Alarm registers									
09h	Minute_alarm	AE_M	MINUTE_ALARM (0 to 59)						
0Ah	Hour_alarm	AE_H	-	HOUR_ALARM (0 to 23)					
0Bh	Day_alarm	AE_D	-	DAY_ALARM (1 to 31)					
0Ch	Weekday_alarm	AE_W	-	-	-	-	WEEKDAY_ALARM (0 to 6)		
CLKOUT control register									
0Dh	CLKOUT_control	FE	-	-	-	-	-	FD	
Timer registers									
0Eh	Timer_control	TE	-	-	-	-	-	TD	
0Fh	Timer	COUNTDOWN_TIMER							

8.2 Control registers

8.2.1 Register Control_1

Table 6. Register Control_1 (address 00h) bits description

Bit	Symbol	Value	Description
7	TEST1	0 ^[1]	normal mode
		1	EXT_CLK test mode
6	N	0 ^[2]	default value
5	STOP	0 ^[1]	RTC source clock runs
		1	all RTC divider chain flip-flops are asynchronously set to logic 0; the RTC clock is stopped (CLKOUT at 32.768 kHz is still available)
4	N	0 ^[2]	default value
3	TESTC	0	power-on reset override facility is disabled; set to logic 0 for normal operation
		1 ^[1]	power-on reset override may be enabled
2 to 0	N	000 ^[2]	default value

[1] Default value.

[2] Bits labeled as N should always be written with logic 0.

8.2.2 Register Control_2

Table 7. Register Control_2 (address 01h) bits description

Bit	Symbol	Value	Description
7 to 5	N	000 ^[1]	default value
4	TI_TP	0 ^[2]	$\overline{\text{INT}}$ is active when TF is active (subject to the status of TIE)
		1	$\overline{\text{INT}}$ pulses active according to Table 29 (subject to the status of TIE); Remark: note that if AF and AIE are active then $\overline{\text{INT}}$ will be permanently active
3	AF	0 ^[2]	alarm flag inactive
		1	alarm flag active
2	TF	0 ^[2]	timer flag inactive
		1	timer flag active
1	AIE	0 ^[2]	alarm interrupt disabled
		1	alarm interrupt enabled
0	TIE	0 ^[2]	timer interrupt disabled
		1	timer interrupt enabled

[1] Bits labeled as N should always be written with logic 0.

[2] Default value.

8.3 Reset

The PCA8565 includes an internal reset circuit which is active whenever the oscillator is stopped. In the reset state the I²C-bus logic is initialized including the address pointer. All other registers are set according to [Table 8](#).

Table 8. Register reset values^[1]

Address	Register name	Bit							
		7	6	5	4	3	2	1	0
00h	Control_1	0	0	0	0	1	0	0	0
01h	Control_2	x	x	0	0	0	0	0	0
02h	Seconds	1	x	x	x	x	x	x	x
03h	Minutes	1	x	x	x	x	x	x	x
04h	Hours	x	x	x	x	x	x	x	x
05h	Days	x	x	x	x	x	x	x	x
06h	Weekdays	x	x	x	x	x	x	x	x
07h	Months_century	x	x	x	x	x	x	x	x
08h	Years	x	x	x	x	x	x	x	x
09h	Minute_alarm	1	x	x	x	x	x	x	x
0Ah	Hour_alarm	1	x	x	x	x	x	x	x
0Bh	Day_alarm	1	x	x	x	x	x	x	x
0Ch	Weekday_alarm	1	x	x	x	x	x	x	x
0Dh	CLKOUT_control	1	x	x	x	x	x	0	0
0Eh	Timer_control	0	x	x	x	x	x	1	1
0Fh	Timer	x	x	x	x	x	x	x	x

[1] Registers labeled 'x' are undefined at power-on and unchanged by subsequent resets.

8.3.1 Power-On Reset (POR) override

The POR duration is directly related to the crystal oscillator start-up time. Due to the long start-up times experienced by these types of circuits, a mechanism has been built in to disable the POR and hence speed up on-board test of the device. The setting of this mode requires that the I²C-bus pins, SDA and SCL, be toggled in a specific order as shown in [Figure 3](#). All timings are required minimums.

Once the override mode has been entered, the device immediately stops being reset and normal operation may commence i.e. entry into the EXT_CLK test mode via I²C-bus access. The override mode may be cleared by writing a logic 0 to TESTC. TESTC must be set to logic 1 before re-entry into the override mode is possible. Setting TESTC to logic 0 during normal operation has no effect except to prevent entry into the POR override mode.

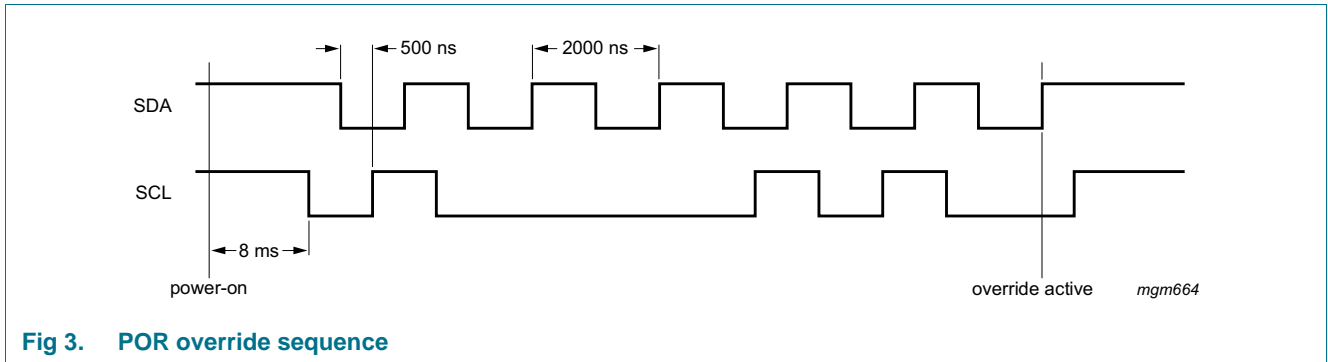

Fig 3. POR override sequence

8.4 Time and date registers

The majority of the registers are coded in the BCD format to simplify application use.

8.4.1 Register Seconds

Table 9. Register Seconds (address 02h) bits description

Bit	Symbol	Value	Place value	Description
7	VL	0	-	clock integrity is guaranteed
		1 ^[1]	-	integrity of the clock information is not guaranteed
6 to 4	SECONDS	0 to 5	ten's place	actual seconds coded in BCD format
3 to 0		0 to 9	unit place	

[1] Start-up value.

Table 10. Seconds coded in BCD format

Seconds value in decimal	Upper-digit (ten's place)			Digit (unit place)			
	Bit 6	Bit 5	Bit 4	Bit 3	Bit 2	Bit 1	Bit 0
00	0	0	0	0	0	0	0
01	0	0	0	0	0	0	1
02	0	0	0	0	0	1	0
:							
09	0	0	0	1	0	0	1
10	0	0	1	0	0	0	0
:							
58	1	0	1	1	0	0	0
59	1	0	1	1	0	0	1

8.4.1.1 Voltage-low detector

The PCA8565 has an on-chip voltage-low detector. When V_{DD} drops below V_{low} , bit VL in the Seconds register is set to indicate that the integrity of the clock information is no longer guaranteed. The VL flag is cleared by command.

Bit VL is intended to detect the situation when V_{DD} is decreasing slowly, for example under battery operation. Should V_{DD} reach V_{low} before power is re-asserted then bit VL is set. This indicates that the time may be corrupt (see Figure 4).

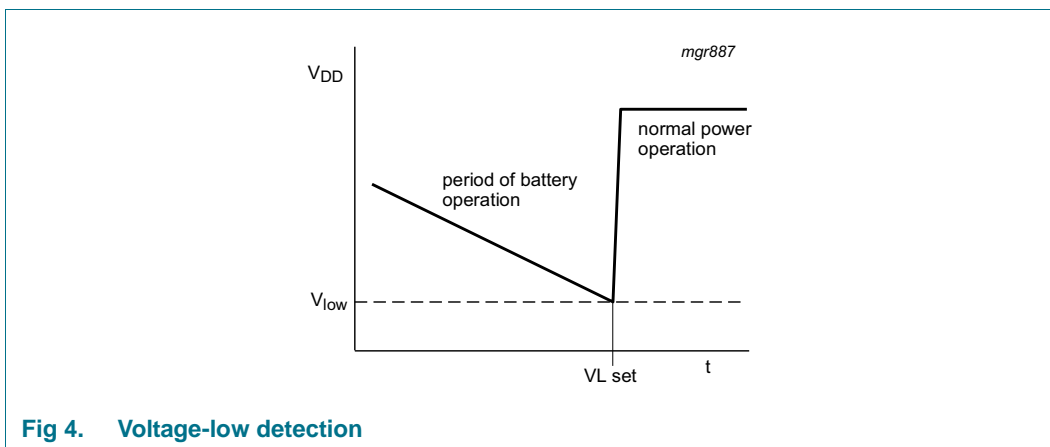

Fig 4. Voltage-low detection

8.4.2 Register Minutes

Table 11. Register Minutes (address 03h) bits description

Bit	Symbol	Value	Place value	Description
7	-	-	-	unused
6 to 4	MINUTES	0 to 5	ten's place	actual minutes coded in BCD format
3 to 0		0 to 9	unit place	

8.4.3 Register Hours

Table 12. Register Hours (address 04h) bits description

Bit	Symbol	Value	Place value	Description
7 to 6	-	-	-	unused
5 to 4	HOURS	0 to 2	ten's place	actual hours coded in BCD format
3 to 0		0 to 9	unit place	

8.4.4 Register Days

Table 13. Register Days (address 05h) bits description

Bit	Symbol	Value	Place value	Description
7 to 6	-	-	-	unused
5 to 4	DAYS ^[1]	0 to 3	ten's place	actual day coded in BCD format
3 to 0		0 to 9	unit place	

[1] The PCA8565 compensates for leap years by adding a 29th day to February if the year counter contains a value which is exactly divisible by 4, including the year 00.

8.4.5 Register Weekdays

Table 14. Register Weekdays (address 06h) bits description

Bit	Symbol	Value	Description
7 to 3	-	-	unused
2 to 0	WEEKDAYS	0 to 6	actual weekday values, see Table 15

Table 15. Weekday assignments

Day ^[1]	Bit		
	2	1	0
Sunday	0	0	0
Monday	0	0	1
Tuesday	0	1	0
Wednesday	0	1	1
Thursday	1	0	0
Friday	1	0	1
Saturday	1	1	0

[1] Definition may be re-assigned by the user.

8.4.6 Register Months_century

Table 16. Register Months_century (address 07h) bits description

Bit	Symbol	Value	Place value	Description
7	C ^[1]	0 ^[2]	-	indicates the century is x
		1	-	indicates the century is x + 1
6 to 5	-	-	-	unused
4	MONTHS	0 to 1	ten's place	actual month coded in BCD format, see Table 17
3 to 0		0 to 9	unit place	

[1] This bit may be re-assigned by the user.

[2] This bit is toggled when the years register overflows from 99 to 00.

Table 17. Month assignments coded in BCD format

Month	Upper-digit (ten's place)	Digit (unit place)			
	Bit 4	Bit 3	Bit 2	Bit 1	Bit 0
January	0	0	0	0	1
February	0	0	0	1	0
March	0	0	0	1	1
April	0	0	1	0	0
May	0	0	1	0	1
June	0	0	1	1	0
July	0	0	1	1	1
August	0	1	0	0	0
September	0	1	0	0	1
October	1	0	0	0	0
November	1	0	0	0	1
December	1	0	0	1	0

8.4.7 Register Years

Table 18. Register Years (08h) bits description

Bit	Symbol	Value	Place value	Description
7 to 4	YEARS	0 to 9	ten's place	actual year coded in BCD format
3 to 0		0 to 9	unit place	

8.5 Setting and reading the time

Figure 5 shows the data flow and data dependencies starting from the 1 Hz clock tick.

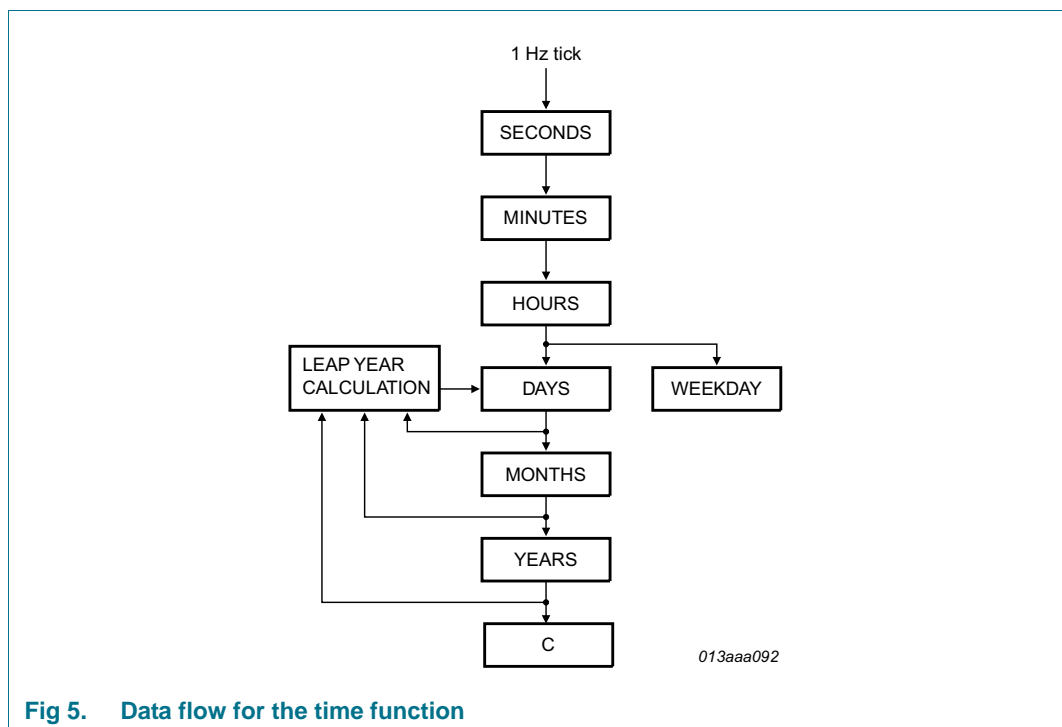

Fig 5. Data flow for the time function

During read/write operations, the time counting circuits (memory locations 02h through 08h) are blocked.

This prevents

- Faulty reading of the clock and calendar during a carry condition
- Incrementing the time registers, during the read cycle

After this read/write access is completed, the time circuit is released again and any pending request to increment the time counters that occurred during the read access is serviced. A maximum of 1 request can be stored; therefore, all accesses must be completed within 1 second (see Figure 6).

As a consequence of this method, it is very important to make a read or write access in one go, that is, setting or reading seconds through to years should be made in one single access. Failing to comply with this method could result in the time becoming corrupted.

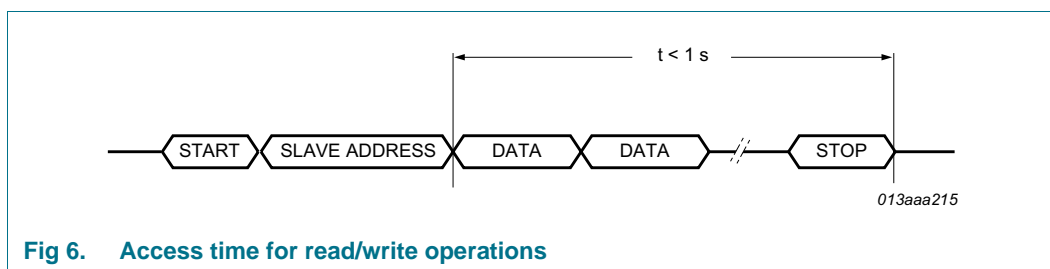

Fig 6. Access time for read/write operations

As an example, if the time (seconds through to hours) is set in one access and then in a second access the date is set, it is possible that the time may increment between the two accesses. A similar problem exists when reading. A roll over may occur between reads thus giving the minutes from one moment and the hours from the next.

Recommended method for reading the time:

1. Send a START condition and the slave address for write (A2h).
2. Set the address pointer to registers Seconds (02h).
3. Send a RESTART condition or STOP followed by START.
4. Send the slave address for read (A3h).
5. Read the register Seconds.
6. Read the register Minutes.
7. Read the register Hours.
8. Read the register Days.
9. Read the register Weekdays.
10. Read the register Months_century.
11. Read the register Years.
12. Send a STOP condition.

8.6 Alarm registers

When one or more of the alarm registers are loaded with a valid minute, hour, day or weekday and its corresponding bit alarm enable (AE_x) is logic 0, then that information is compared with the actual minute, hour, day and weekday.

When all enabled comparisons first match, the Alarm Flag (AF) is set. AF will remain set until cleared by command. **Once AF has been cleared it is only set again when the time increments to match the alarm condition once more.** (For clearing the AF, see [Section 8.9.1.1 on page 18.](#))

Alarm registers which have their bit AE_x at logic 1 are ignored.

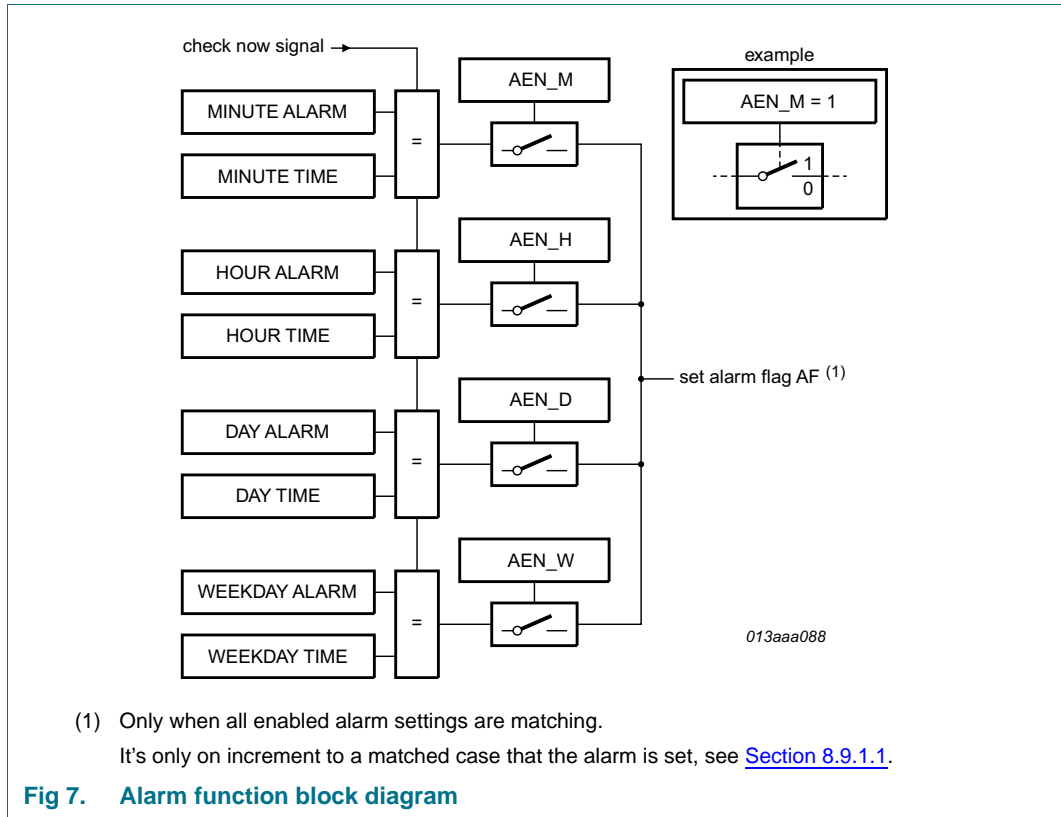

8.6.1 Register Minute_alarm

Table 19. Register Minute_alarm (address 09h) bits description

Bit	Symbol	Value	Place value	Description
7	AE_M	0	-	minute alarm is enabled
		1 ^[1]	-	minute alarm is disabled
6 to 4	MINUTE_ALARM	0 to 5	ten's place	minute alarm information coded in BCD format
3 to 0		0 to 9	unit place	

[1] Default value.

8.6.2 Register Hour_alarm

Table 20. Register Hour_alarm (address 0Ah) bits description

Bit	Symbol	Value	Place value	Description
7	AE_H	0	-	hour alarm is enabled
		1 ^[1]	-	hour alarm is disabled
6	-	-	-	unused
5 to 4	HOUR_ALARM	0 to 2	ten's place	hour alarm information coded in BCD format
3 to 0		0 to 9	unit place	

[1] Default value.

8.6.3 Register Day_alarm

Table 21. Register Day_alarm (address 0Bh) bits description

Bit	Symbol	Value	Place value	Description
7	AE_D	0	-	day alarm is enabled
		1 ^[1]	-	day alarm is disabled
6	-	-	-	unused
5 to 4	DAY_ALARM	0 to 3	ten's place	day alarm information coded in BCD format
3 to 0		0 to 9	unit place	

[1] Default value.

8.6.4 Register Weekday_alarm

Table 22. Register Weekday_alarm (address 0Ch) bits description

Bit	Symbol	Value	Description
7	AE_W	0	weekday alarm is enabled
		1 ^[1]	weekday alarm is disabled
6 to 3	-	-	unused
2 to 0	WEEKDAY_ALARM	0 to 6	weekday alarm information coded in BCD format

[1] Default value.

8.7 Timer functions

The 8-bit countdown timer at address 0Fh is controlled by the timer control register at address 0Eh. The timer control register determines one of 4 source clock frequencies for the timer (4.096 kHz, 64 Hz, 1 Hz, or 1/60 Hz) and enables or disables the timer. The timer counts down from a software-loaded 8-bit binary value. At the end of every countdown, the timer sets the timer flag (TF) in the register Control_status_2. The TF may only be cleared by command. The asserted TF can be used to generate an interrupt (on pin INT). The interrupt may be generated as a pulsed signal every countdown period or as a permanently active signal which follows the state of TF. Bit TI_TP is used to control this mode selection. When reading the timer, the current countdown value is returned.

8.7.1 Register Timer_control

The timer register is an 8-bit binary countdown timer. It is enabled and disabled via the bit TE in register Timer_control. The source clock for the timer is also selected by the TD[1:0] in register Timer_control. Other timer properties such as interrupt generation are controlled via register Control_2.

Table 23. Register Timer_control (address 0Eh) bits description

Bit	Symbol	Value	Description
7	TE	0 ^[1]	timer is disabled
		1	timer is enabled
6 to 2	-	-	unused
1 to 0	TD[1:0]		timer source clock frequency select ^[2]
		00	4.096 kHz
		01	64 Hz
		10	1 Hz
		11 ^[2]	1/60 Hz

[1] Default value.

[2] These bits determine the source clock for the countdown timer; when not in use, TD[1:0] should be set to 1/60 Hz for power saving.

8.7.2 Register Countdown_Timer

Table 24. Timer (address 0Fh) bits description

Bit	Symbol	Value	Description
7 to 0	COUNTDOWN_TIMER	00h to FFh	countdown period in seconds: $CountdownPeriod = \frac{n}{SourceClockFrequency}$ where n is the countdown value

Table 25. Timer register bits value range

Bit							
7	6	5	4	3	2	1	0
128	64	32	16	8	4	2	1

The timer register is an 8-bit binary countdown timer. It is enabled or disabled via the Timer_control register. The source clock for the timer is also selected by the Timer_control register. Other timer properties such as single or periodic interrupt generation are controlled via the register Control_status_2 (address 01h).

For accurate read back of the count down value, it is recommended to read the register twice and check for consistent results, since it is not possible to freeze the countdown timer counter during read back.

8.8 Register CLKOUT_control and clock output

A programmable square wave is available at pin CLKOUT. Operation is controlled by the CLKOUT_control register at address 0Dh. Frequencies of 32.768 kHz (default), 1.024 kHz, 32 Hz and 1 Hz can be generated for use as a system clock, microcontroller clock, input to a charge pump, or for calibration of the oscillator. CLKOUT is an open-drain output and enabled at power-on. If disabled it becomes high-impedance.

Table 26. Register CLKOUT_control (address 0Dh) bits description

Bit	Symbol	Value	Description
7	FE	0	the CLKOUT output is inhibited and CLKOUT output is set to high-impedance
		1 ^[1]	the CLKOUT output is activated
6 to 2	-	-	unused
1 to 0	FD[1:0]		frequency output at pin CLKOUT
		00 ^[1]	32.768 kHz
		01	1.024 kHz
		10	32 Hz
		11	1 Hz

[1] Default value.

8.9 Interrupt output

8.9.1 Bits TF and AF

When an alarm occurs, AF is set to 1. Similarly, at the end of a timer countdown, TF is set to 1. These bits maintain their value until overwritten by command. If both timer and alarm interrupts are required in the application, the source of the interrupt is determined by reading these bits.

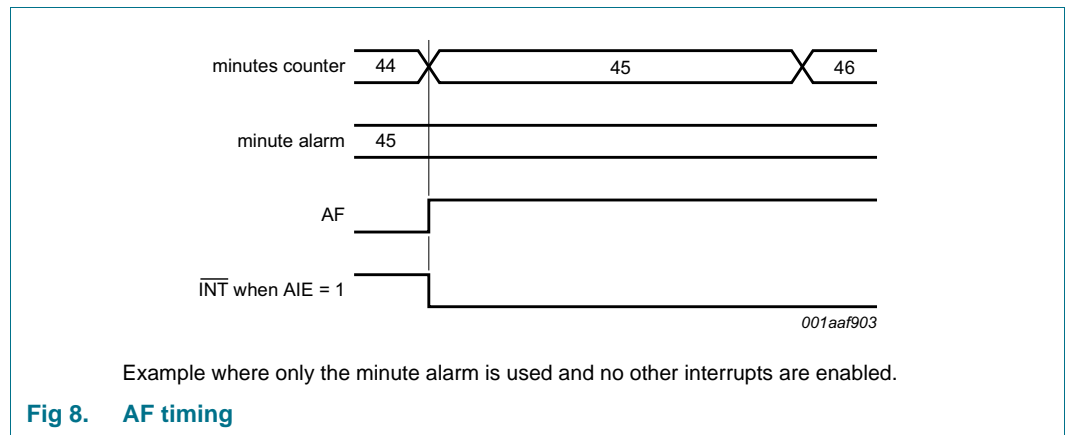

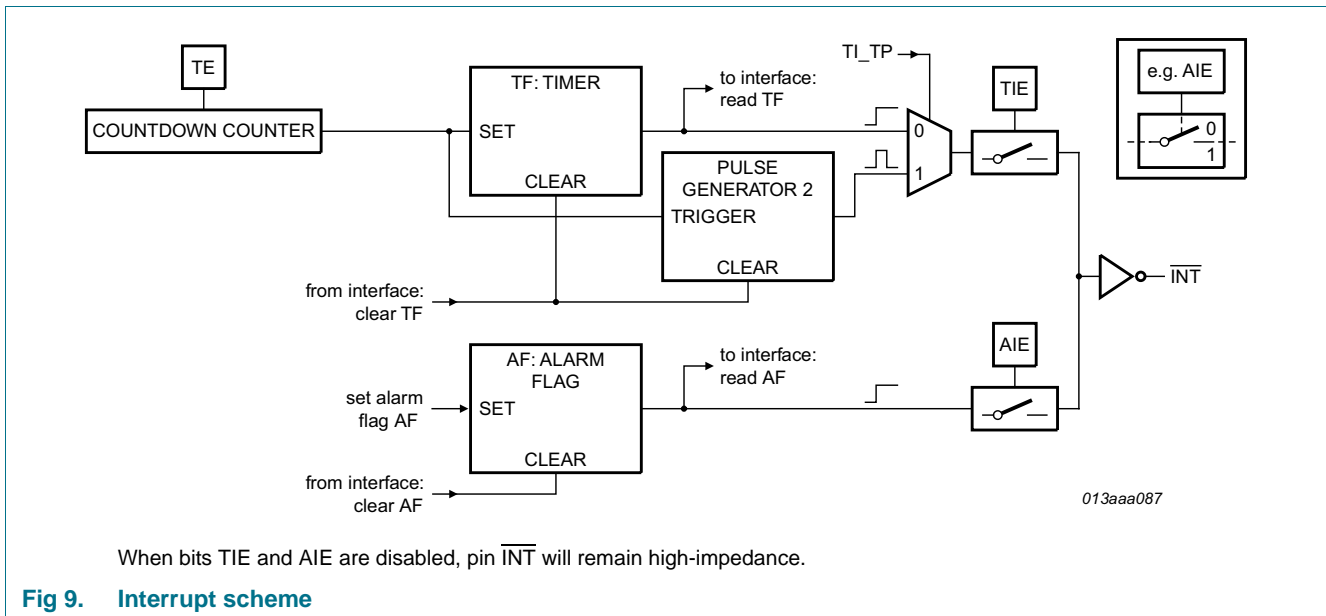

8.9.1.1 Clearing the alarm flag (AF)

Table 28 shows an example for clearing bit AF but leaving bit TF unaffected. Clearing the flags is made by a write command; therefore bits 7, 6, 4, 1 and 0 must be written with their previous values. Repeatedly re-writing these bits has no influence on the functional behavior.

To prevent the timer flags being overwritten while clearing AF, a logical AND is performed during a write access. Writing a logic 1 will cause the flag to maintain its value, whereas writing a logic 0 will cause the flag to be reset.

Table 27. Flag location in register Control_2

Register	Bit							
	7	6	5	4	3	2	1	0
Control_2	-	-	-	-	AF	TF	-	-

The following table shows what instruction must be sent to clear bit AF. In this example bit TF is unaffected.

Table 28. Example to clear only AF (bit 3) in register Control_2

Register	Bit							
	7	6	5	4	3	2	1	0
Control_2	-	-	-	-	0	1	-	-

8.9.2 Bits TIE and AIE

These bits activate or deactivate the generation of an interrupt when TF or AF is asserted respectively. The interrupt is the logical OR of these two conditions when both AIE and TIE are set.

8.9.3 Countdown timer interrupts

The pulse generator for the countdown timer interrupt uses an internal clock and is dependent on the selected source clock for the countdown timer and on the countdown value n. As a consequence, the width of the interrupt pulse varies (see [Table 29](#)).

Table 29. $\overline{\text{INT}}$ operation (bit TI_TP = 1)

Source clock (Hz)	$\overline{\text{INT}}$ period (s)	
	n = 1 ^[1]	n > 1
4096	$\frac{1}{8192}$	$\frac{1}{4096}$
64	$\frac{1}{128}$	$\frac{1}{64}$
1	$\frac{1}{64}$	$\frac{1}{64}$
$\frac{1}{60}$	$\frac{1}{64}$	$\frac{1}{64}$

[1] n = loaded countdown value. Timer stopped when n = 0.

8.10 External clock (EXT_CLK) test mode

A test mode is available which allows for on-board testing. In such a mode it is possible to set up test conditions and control the operation of the RTC.

The test mode is entered by setting bit TEST1 in register Control_1. Then pin CLKOUT becomes an input. The test mode replaces the internal 64 Hz signal with the signal applied to pin CLKOUT. Every 64 positive edges applied to pin CLKOUT will then generate an increment of one second.

The signal applied to pin CLKOUT should have a minimum pulse width of 300 ns and a maximum period of 1000 ns. The internal 64 Hz clock, now sourced from CLKOUT, is divided down to 1 Hz by a 2⁶ divide chain called a prescaler. The prescaler can be set into a known state by using bit STOP. When bit STOP is set, the prescaler is reset to 0 (STOP must be cleared before the prescaler can operate again).

From a STOP condition, the first 1 second increment will take place after 32 positive edges on CLKOUT. Thereafter, every 64 positive edges will cause a 1 second increment.

Remark: Entry into EXT_CLK test mode is not synchronized to the internal 64 Hz clock. When entering the test mode, no assumption as to the state of the prescaler can be made.

Operation example:

1. Set EXT_CLK test mode (Control_1, bit TEST1 = 1).
2. Set STOP (Control_1, bit STOP = 1).
3. Clear STOP (Control_1, bit STOP = 0).
4. Set time registers to desired value.
5. Apply 32 clock pulses to CLKOUT.
6. Read time registers to see the first change.
7. Apply 64 clock pulses to CLKOUT.
8. Read time registers to see the second change.

Repeat 7 and 8 for additional increments.

8.11 STOP bit function

The function of the STOP bit is to allow for accurate starting of the time circuits. The STOP bit function will cause the upper part of the prescaler (F_2 to F_{14}) to be held in reset and thus no 1 Hz ticks will be generated (see Figure 10). The time circuits can then be set and will not increment until the STOP bit is released (see Figure 11 and Table 30).

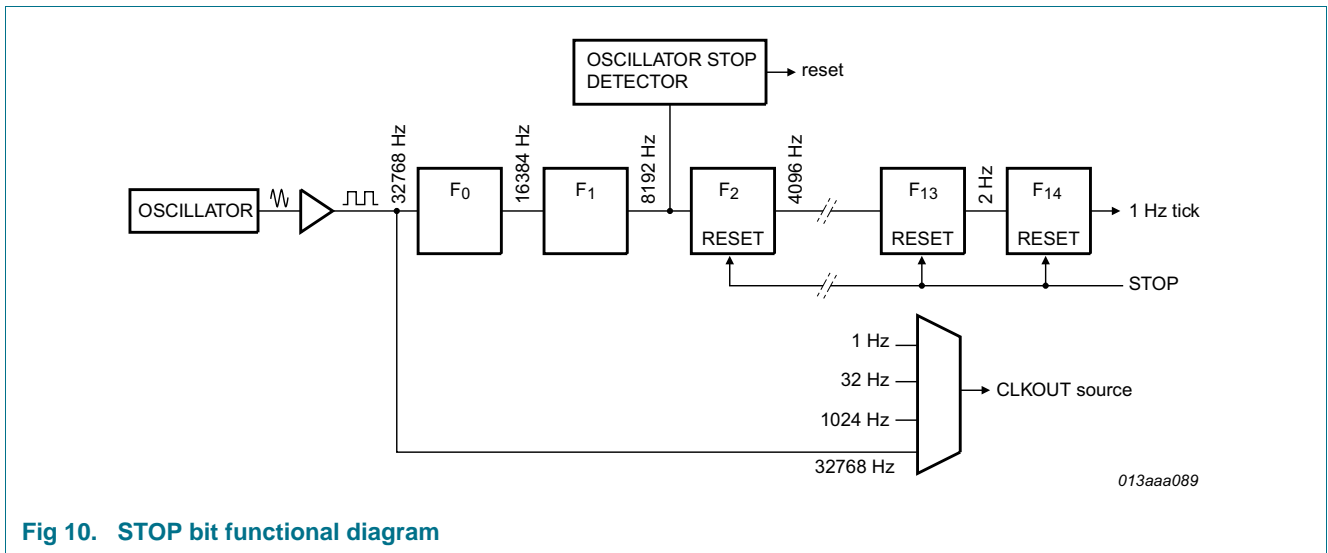

Fig 10. STOP bit functional diagram

The STOP bit function will not affect the output of 32.768 kHz but will stop 1.024 kHz, 32 Hz and 1 Hz.

The lower two stages of the prescaler (F_0 and F_1) are not reset and because the I²C-bus is asynchronous to the crystal oscillator, the accuracy of re-starting the time circuits will be between zero and one 8.192 kHz cycle (see Figure 11).

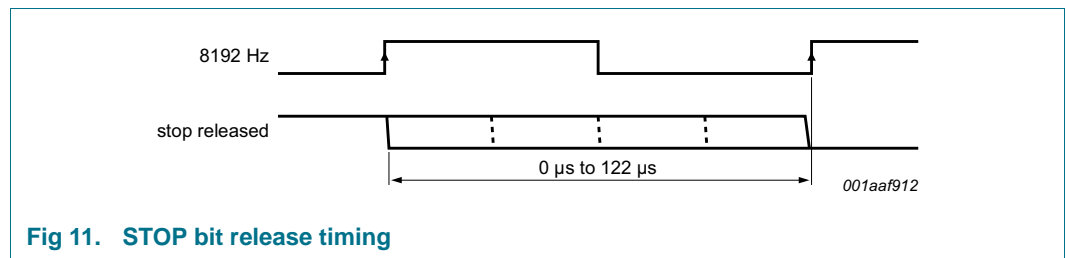

Fig 11. STOP bit release timing

Table 30. First increment of time circuits after STOP bit release

Bit	Prescaler bits	[1] 1 Hz tick	Time	Comment
STOP	F ₀ F ₁ -F ₂ to F ₁₄		hh:mm:ss	
Clock is running normally				
0	01-0 0001 1101 0100		12:45:12	prescaler counting normally
STOP bit is activated by user. F₀F₁ are not reset and values cannot be predicted externally				
1	XX-0 0000 0000 0000		12:45:12	prescaler is reset; time circuits are frozen
New time is set by user				
1	XX-0 0000 0000 0000		08:00:00	prescaler is reset; time circuits are frozen
STOP bit is released by user				
0	XX-0 0000 0000 0000		08:00:00	prescaler is now running
	XX-1 0000 0000 0000		08:00:00	-
	XX-0 1000 0000 0000		08:00:00	-
	XX-1 1000 0000 0000		08:00:00	-
	:		:	:
	11-1 1111 1111 1110		08:00:00	-
	00-0 0000 0000 0001		08:00:01	0 to 1 transition of F ₁₄ increments the time circuits
	10-0 0000 0000 0001		08:00:01	-
	:		:	:
	11-1 1111 1111 1111		08:00:01	-
	00-0 0000 0000 0000		08:00:01	-
	10-0 0000 0000 0000		08:00:01	-
	:		:	:
	11-1 1111 1111 1110		08:00:01	-
	00-0 0000 0000 0001		08:00:02	0 to 1 transition of F ₁₄ increments the time circuits

[1] F₀ is clocked at 32.768 kHz.

The first increment of the time circuits is between 0.507813 s and 0.507935 s after STOP bit is released. The uncertainty is caused by the prescaler bits F₀ and F₁ not being reset (see [Table 30](#)) and the unknown state of the 32 kHz clock.

9. Characteristics of the I²C-bus

The I²C-bus is for bidirectional, two-line communication between different ICs or modules. The two lines are a Serial Data Line (SDA) and a Serial CLock line (SCL). Both lines must be connected to a positive supply via a pull-up resistor. Data transfer may be initiated only when the bus is not busy.

9.1 Bit transfer

One data bit is transferred during each clock pulse. The data on the SDA line must remain stable during the HIGH period of the clock pulse as changes in the data line at this time will be interpreted as a control signal (see [Figure 12](#)).

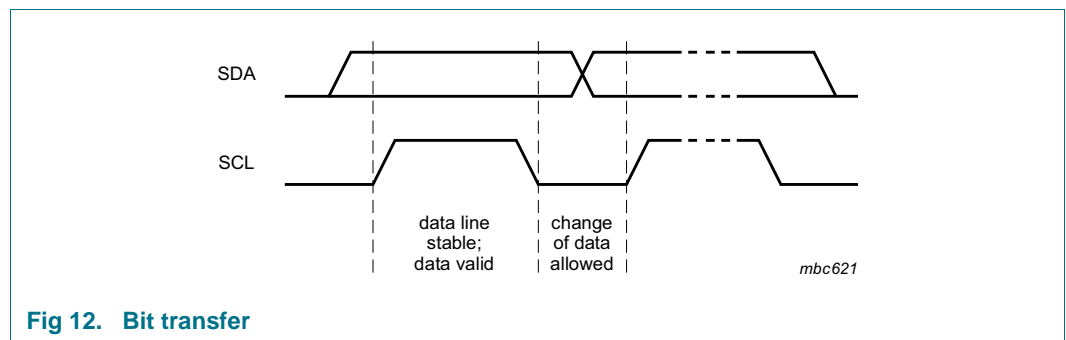

Fig 12. Bit transfer

9.2 START and STOP conditions

Both data and clock lines remain HIGH when the bus is not busy. A HIGH-to-LOW transition of the data line, while the clock is HIGH is defined as the START condition (S). A LOW-to-HIGH transition of the data line while the clock is HIGH is defined as the STOP condition (P), see [Figure 13](#).

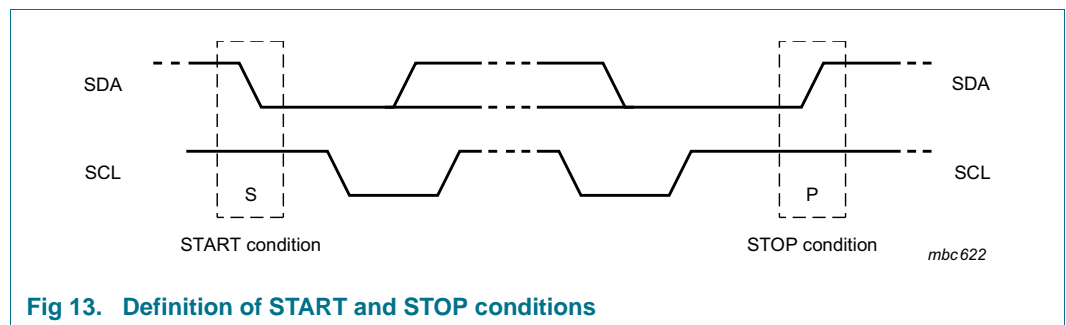

Fig 13. Definition of START and STOP conditions

9.3 System configuration

A device generating a message is a transmitter, a device receiving a message is the receiver. The device that controls the message is the master and the devices which are controlled by the master are the slaves (see [Figure 14](#)).

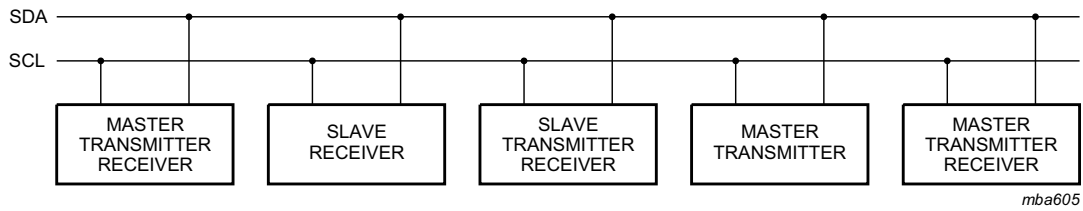

Fig 14. System configuration

9.4 Acknowledge

The number of data bytes transferred between the START and STOP conditions from transmitter to receiver is unlimited. Each byte of eight bits is followed by an acknowledge cycle.

- A slave receiver, which is addressed, must generate an acknowledge after the reception of each byte.
- A master receiver must generate an acknowledge after the reception of each byte that has been clocked out of the slave transmitter.
- The device that acknowledges must pull-down the SDA line during the acknowledge clock pulse, so that the SDA line is stable LOW during the HIGH period of the acknowledge related clock pulse (set-up and hold times must be taken into consideration).
- A master receiver must signal an end of data to the transmitter by not generating an acknowledge on the last byte that has been clocked out of the slave. In this event, the transmitter must leave the data line HIGH to enable the master to generate a STOP condition.

Acknowledgement on the I²C-bus is shown in [Figure 15](#).

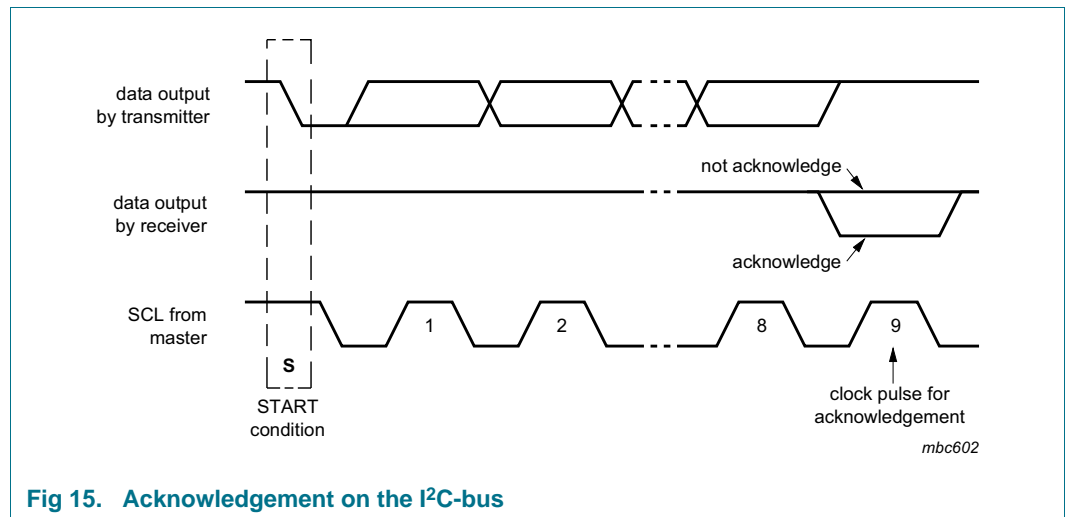

Fig 15. Acknowledgement on the I²C-bus

9.5 I²C-bus protocol

9.5.1 Addressing

Before any data is transmitted on the I²C-bus, the device which should respond is addressed first. The addressing is always carried out with the first byte transmitted after the start procedure.

The PCA8565 acts as a slave receiver or slave transmitter. Therefore the clock signal SCL is only an input signal, but the data signal SDA is a bidirectional line.

The PCA8565 slave address is shown in [Figure 16](#).

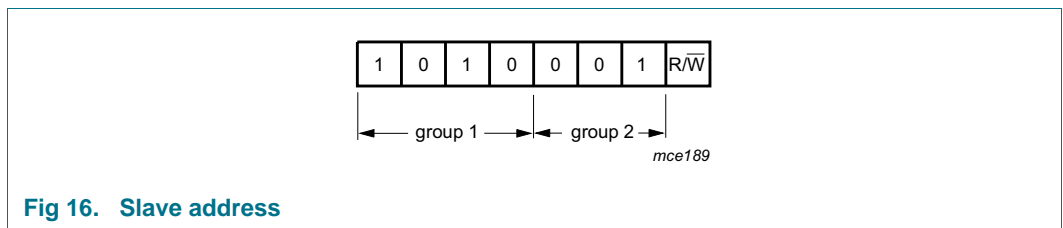

Fig 16. Slave address

9.5.2 Clock and calendar read/write cycles

The I²C-bus configuration for the different PCA8565 read and write cycles is shown in [Figure 17](#), [Figure 18](#) and [Figure 19](#). The word address is a 4-bit value that defines which register is to be accessed next. The upper four bits of the word address are not used.

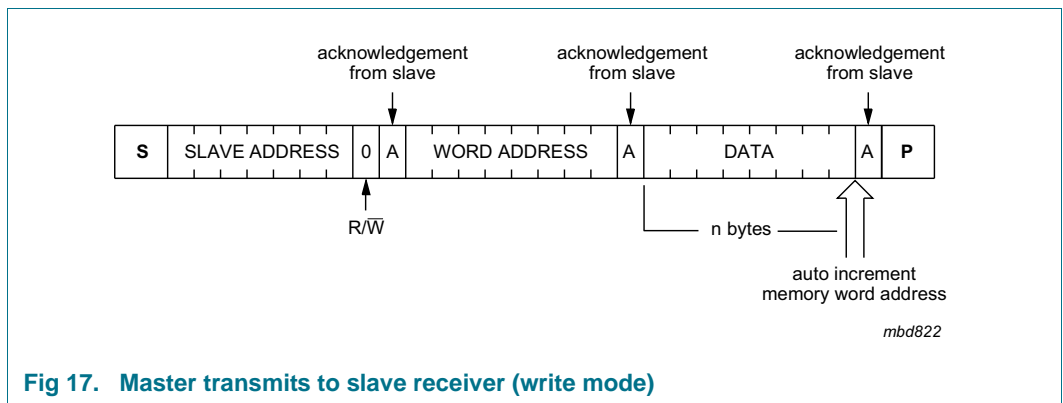

Fig 17. Master transmits to slave receiver (write mode)

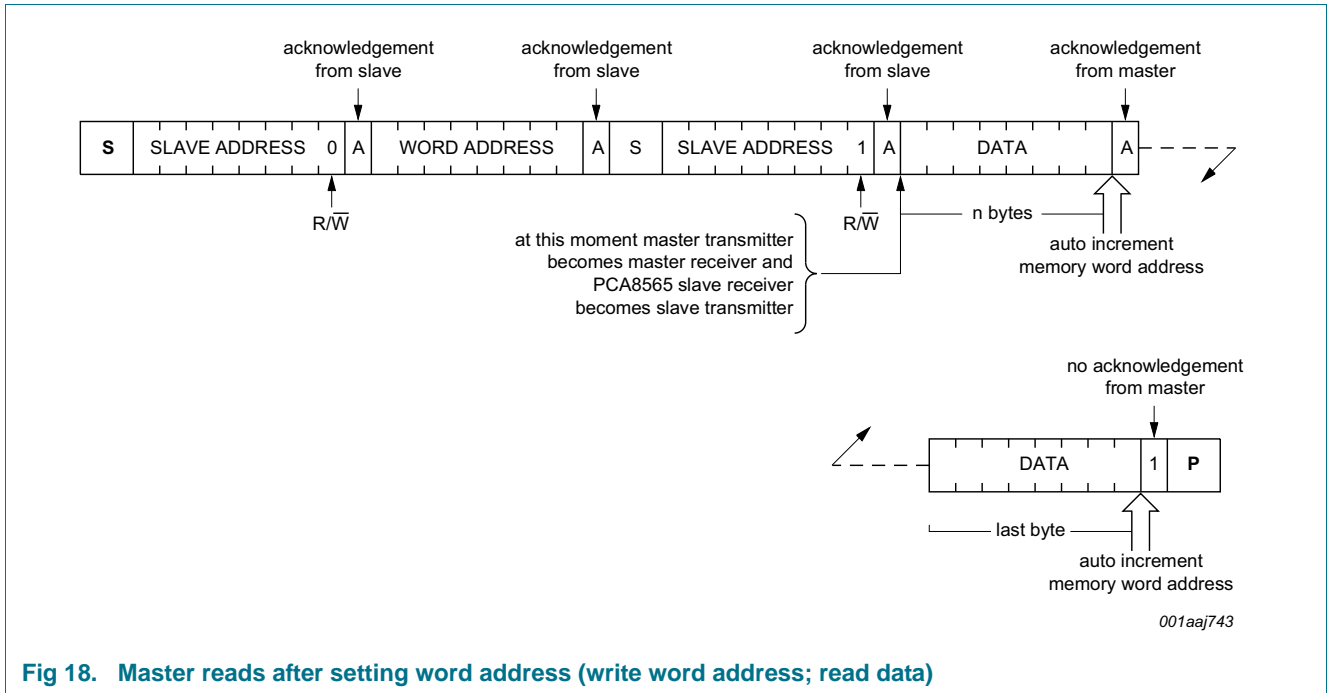

Fig 18. Master reads after setting word address (write word address; read data)

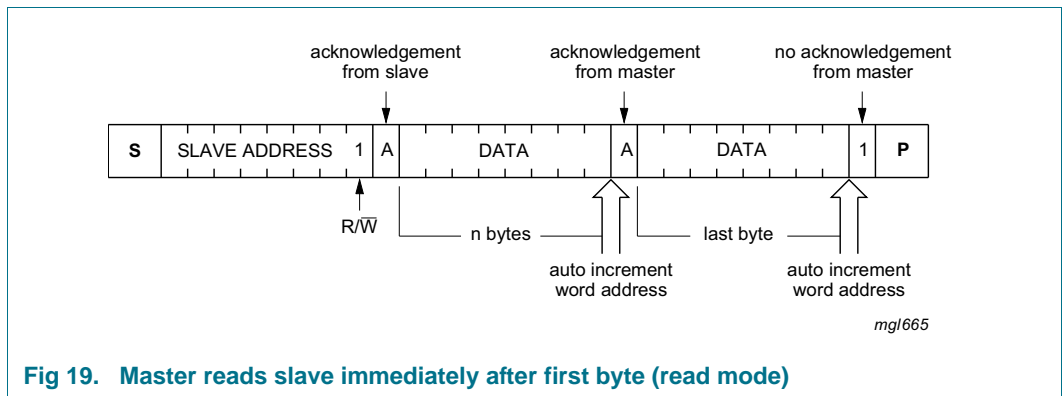

Fig 19. Master reads slave immediately after first byte (read mode)

9.5.3 Interface watchdog timer

During read/write operations, the time counting circuits are frozen. To prevent a situation where the accessing device becomes locked and does not clear the interface, the PCA8565 has a built in watchdog timer. Should the interface be active for more than 1 s from the time a valid slave address is transmitted, then the PCA8565 will automatically clear the interface and allow the time counting circuits to continue counting. Under a correct data transfer, the watchdog timer is stopped on receipt of a START or STOP condition.

The watchdog is implemented to prevent the excessive loss of time due to interface access failure e.g. if main power is removed from a battery backed-up system during an interface access.

Each time the watchdog period is exceeded, 1 s will be lost from the time counters. The watchdog will trigger between 1 s and 2 s after receiving a valid slave address.

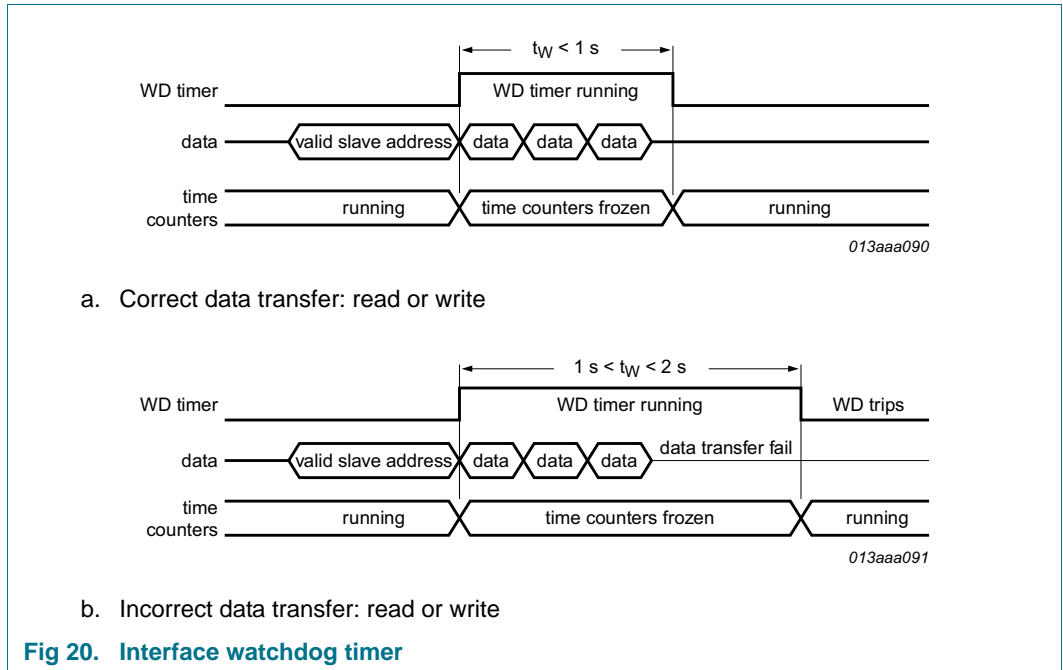

10. Internal circuitry

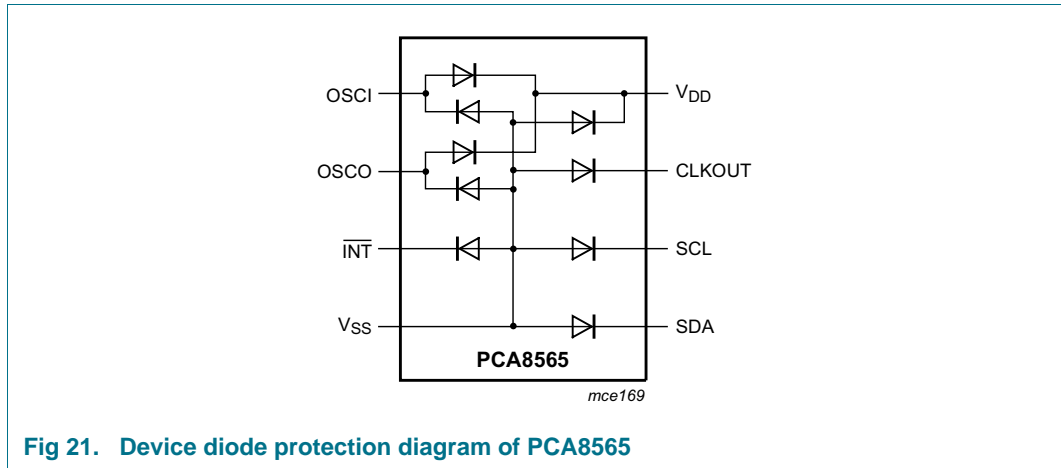

11. Safety notes

CAUTION



This device is sensitive to ElectroStatic Discharge (ESD). Observe precautions for handling electrostatic sensitive devices.

Such precautions are described in the *ANSI/ESD S20.20*, *IEC/ST 61340-5*, *JESD625-A* or equivalent standards.

12. Limiting values

Table 31. Limiting values

In accordance with the Absolute Maximum Rating System (IEC 60134).

Symbol	Parameter	Conditions	Min	Max	Unit	
V _{DD}	supply voltage		-0.5	+6.5	V	
I _{SS}	ground supply current		-50	+50	mA	
I _{DD}	supply current		-50	+50	mA	
V _I	input voltage		-0.5	+6.5	V	
I _I	input current		-10	+10	mA	
I _O	output current		-10	+10	mA	
P _{tot}	total power dissipation		-	300	mW	
V _{ESD}	electrostatic discharge voltage	HBM	[1]	-	±3000	V
		CDM	[2]	-	±1100	V
I _{lu}	latch-up current		[3]	-	250	mA
T _{stg}	storage temperature		[4]	-65	+150	°C
T _{amb}	ambient temperature			-40	+125	°C

[1] Pass level; Human Body Model (HBM) according to [Ref. 6 "JESD22-A114"](#).

[2] Pass level; Charged-Device Model (CDM), according to [Ref. 7 "JESD22-C101"](#).

[3] Pass level; latch-up testing, according to [Ref. 8 "JESD78"](#).

[4] According to the store and transport requirements (see [Ref. 14 "UM10569"](#)) the devices have to be stored at a temperature of +8 °C to +45 °C and a humidity of 25 % to 75 %.

13. Static characteristics

Table 32. Static characteristics

$V_{DD} = 1.8\text{ V to }5.5\text{ V}$; $V_{SS} = 0\text{ V}$; $T_{amb} = -40\text{ °C to }+125\text{ °C}$; $f_{osc} = 32.768\text{ kHz}$; quartz $R_s = 40\text{ k}\Omega$; $C_L = 8\text{ pF}$; unless otherwise specified.

Symbol	Parameter	Conditions	Min	Typ	Max	Unit
Supplies						
V_{DD}	supply voltage		1.8	-	5.5	V
		for clock data integrity	V_{low}	-	5.5	V
V_{low}	low voltage	for low voltage detection	-	0.9	1.7	V
I_{DD}	supply current	interface active				
		$f_{SCL} = 400\text{ kHz}$	-	-	820	μA
		$f_{SCL} = 100\text{ kHz}$	-	-	220	μA
		interface inactive ($f_{SCL} = 0\text{ Hz}$); $T_{amb} = 25\text{ °C}$ [1]				
		CLKOUT disabled				
		$V_{DD} = 5.0\text{ V}$	-	750	1500	nA
		$V_{DD} = 4.0\text{ V}$	-	700	1400	nA
		$V_{DD} = 3.0\text{ V}$	-	650	1300	nA
		$V_{DD} = 2.0\text{ V}$	-	600	1200	nA
		$V_{DD} = 5.0\text{ V}$; $T_{amb} = 125\text{ °C}$ [2]	-	750	5000	nA
		CLKOUT enabled at 32 kHz [1]				
		$V_{DD} = 5.0\text{ V}$	-	1000	2000	nA
		$V_{DD} = 4.0\text{ V}$	-	900	1800	nA
		$V_{DD} = 3.0\text{ V}$	-	800	1600	nA
$V_{DD} = 2.0\text{ V}$	-	700	1400	nA		
$V_{DD} = 5.0\text{ V}$; $T_{amb} = 125\text{ °C}$ [2]	-	1000	6000	nA		
Inputs						
V_{IL}	LOW-level input voltage		$V_{SS} - 0.3$	-	$0.3V_{DD}$	V
V_{IH}	HIGH-level input voltage	on pins SCL and SDA	$0.7V_{DD}$	-	5.5	V
		on pin OSCI	$0.7V_{DD}$	-	$V_{DD} + 0.3$	V
I_{LI}	input leakage current	on pins SCL and SDA; $V_i = V_{DD}$ or V_{SS}	-1	0	+1	μA
C_i	input capacitance	[3]	-	-	7	pF

Table 32. Static characteristics ...continued

$V_{DD} = 1.8\text{ V to }5.5\text{ V}$; $V_{SS} = 0\text{ V}$; $T_{amb} = -40\text{ }^{\circ}\text{C to }+125\text{ }^{\circ}\text{C}$; $f_{osc} = 32.768\text{ kHz}$; quartz $R_s = 40\text{ k}\Omega$; $C_L = 8\text{ pF}$; unless otherwise specified.

Symbol	Parameter	Conditions	Min	Typ	Max	Unit
Outputs						
I_{OL}	LOW-level output current	output sink current				
		$V_{OL} = 0.4\text{ V}$; $V_{DD} = 5\text{ V}$				
		on pin SDA	3	-	-	mA
		on pin $\overline{\text{INT}}$	1	-	-	mA
		$V_O = V_{DD}$ or V_{SS}				
	on pin CLKOUT	1	-	-	mA	
I_{LO}	output leakage current		-1	0	+1	μA

- [1] Timer source clock = $\frac{1}{60}$ Hz, level of pins SCL and SDA is V_{DD} or V_{SS} .
- [2] Worst case is at high temperature and high supply voltage.
- [3] Tested on sample basis.

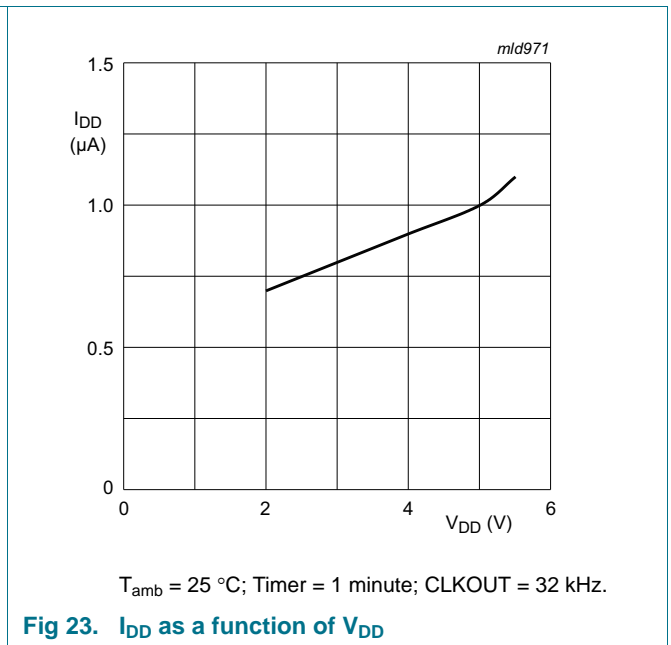
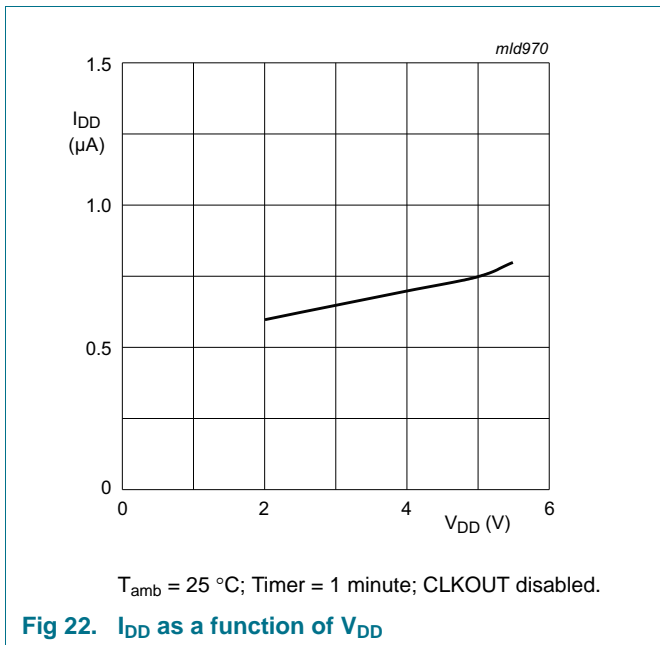

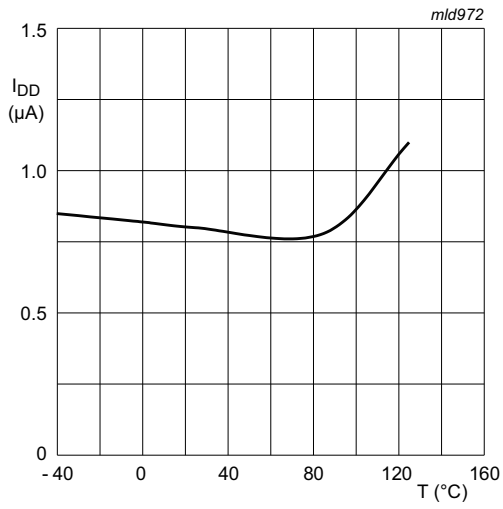

V_{DD} = 3 V; Timer = 1 minute; CLKOUT = 32 kHz.

Fig 24. I_{DD} as a function of temperature

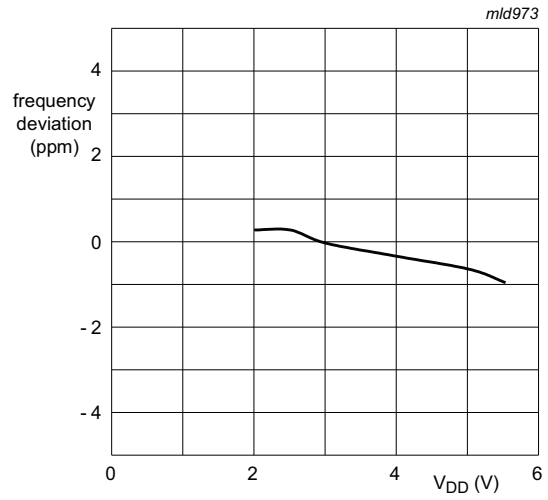

T_{amb} = 25 °C; normalized to V_{DD} = 3 V.

Fig 25. Frequency deviation as a function of V_{DD}

14. Dynamic characteristics

Table 33. Dynamic characteristics

$V_{DD} = 1.8\text{ V to }5.5\text{ V}$; $V_{SS} = 0\text{ V}$; $T_{amb} = -40\text{ °C to }+125\text{ °C}$; $f_{osc} = 32.768\text{ kHz}$; quartz $R_s = 40\text{ k}\Omega$; $C_L = 8\text{ pF}$; unless otherwise specified.

Symbol	Parameter	Conditions	Min	Typ	Max	Unit
Oscillator						
$C_{L(itg)}$	integrated load capacitance	[1]	15	25	35	pF
$\Delta f_{osc}/f_{osc}$	relative oscillator frequency variation	$\Delta V_{DD} = 200\text{ mV}$; $T_{amb} = 25\text{ °C}$	-	0.2	-	ppm
Quartz crystal parameters (f = 32.768 kHz)						
R_s	series resistance		-	-	100	k Ω
C_L	load capacitance		-	10	-	pF
C_{trim}	trimmer capacitance		5	-	25	pF
CLKOUT output						
δ_{CLKOUT}	duty cycle on pin CLKOUT	[2]	-	50	-	%
I²C-bus timing characteristics [3][4]						
f_{SCL}	SCL clock frequency	[5]	-	-	400	kHz
$t_{HD;STA}$	hold time (repeated) START condition		0.6	-	-	μs
$t_{SU;STA}$	set-up time for a repeated START condition		0.6	-	-	μs
t_{LOW}	LOW period of the SCL clock		1.3	-	-	μs
t_{HIGH}	HIGH period of the SCL clock		0.6	-	-	μs
t_r	rise time of both SDA and SCL signals		-	-	0.3	μs
t_f	fall time of both SDA and SCL signals		-	-	0.3	μs
$t_{SU;DAT}$	data set-up time		100	-	-	ns
$t_{HD;DAT}$	data hold time		0	-	-	ns
t_{BUF}	bus free time between a STOP and START condition		4.7	-	-	μs
$t_{SU;STO}$	set-up time for STOP condition		0.6	-	-	μs
t_{SP}	pulse width of spikes that must be suppressed by the input filter		-	-	50	ns
C_b	capacitive load for each bus line		-	-	400	pF

[1] Integrated load capacitance, $C_{L(itg)}$, is a calculation of C_{OSCI} and C_{OSCO} in series. $C_{L(itg)} = \frac{(C_{OSCI} \cdot C_{OSCO})}{(C_{OSCI} + C_{OSCO})}$

[2] For $f_{CLKOUT} = 1.024\text{ kHz}$, 32 Hz and 1 Hz .

[3] All timing values are valid within the operating supply voltage at ambient temperature and referenced to V_{IL} and V_{IH} with an input voltage swing of V_{SS} to V_{DD} .

[4] A detailed description of the I²C-bus specification is given in the document [Ref. 12 "UM10204"](#).

[5] I²C-bus access time between two STARTs or between a START and a STOP condition to this device must be less than one second.

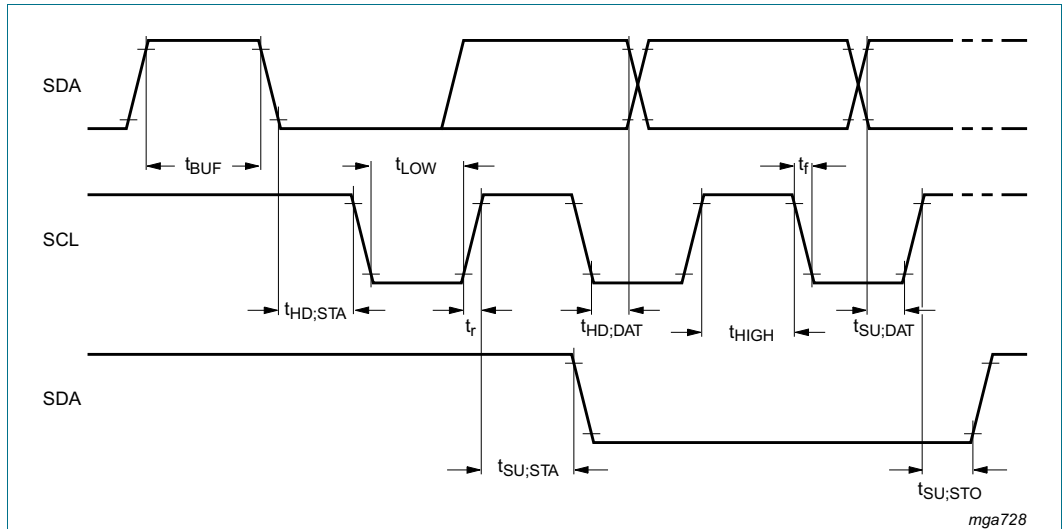

Fig 26. I²C-bus timing waveforms

15. Application information

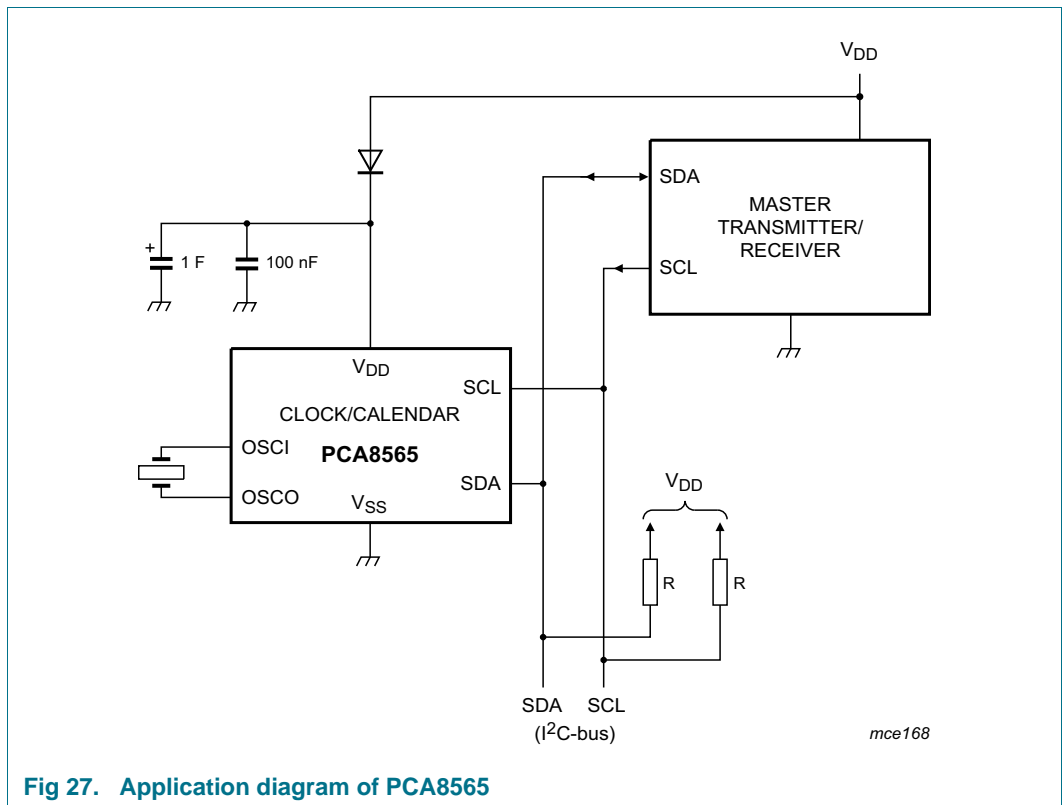

Fig 27. Application diagram of PCA8565

15.1 Quartz frequency adjustment

15.1.1 Method 1: fixed OSCI capacitor

By evaluating the average capacitance necessary for the application layout, a fixed capacitor can be used. The frequency is best measured via the 32.768 kHz signal available after power-on at pin CLKOUT. The frequency tolerance depends on the quartz crystal tolerance, the capacitor tolerance and the device-to-device tolerance (on average $\Delta f/f = \pm 5 \times 10^{-6}$). Average deviations of ± 5 minutes per year can be easily achieved.

15.1.2 Method 2: OSCI trimmer

Using the 32.768 kHz signal available after power-on at pin CLKOUT, fast setting of a trimmer is possible.

15.1.3 Method 3: OSCO output

Direct measurement of OSCO out (allowing for test probe capacitance).

16. Test information

16.1 Quality information

This product has been qualified in accordance with the Automotive Electronics Council (AEC) standard Q100 - *Failure mechanism based stress test qualification for integrated circuits*, and is suitable for use in automotive applications.

17. Package outline

TSSOP8: plastic thin shrink small outline package; 8 leads; body width 3 mm

SOT505-1

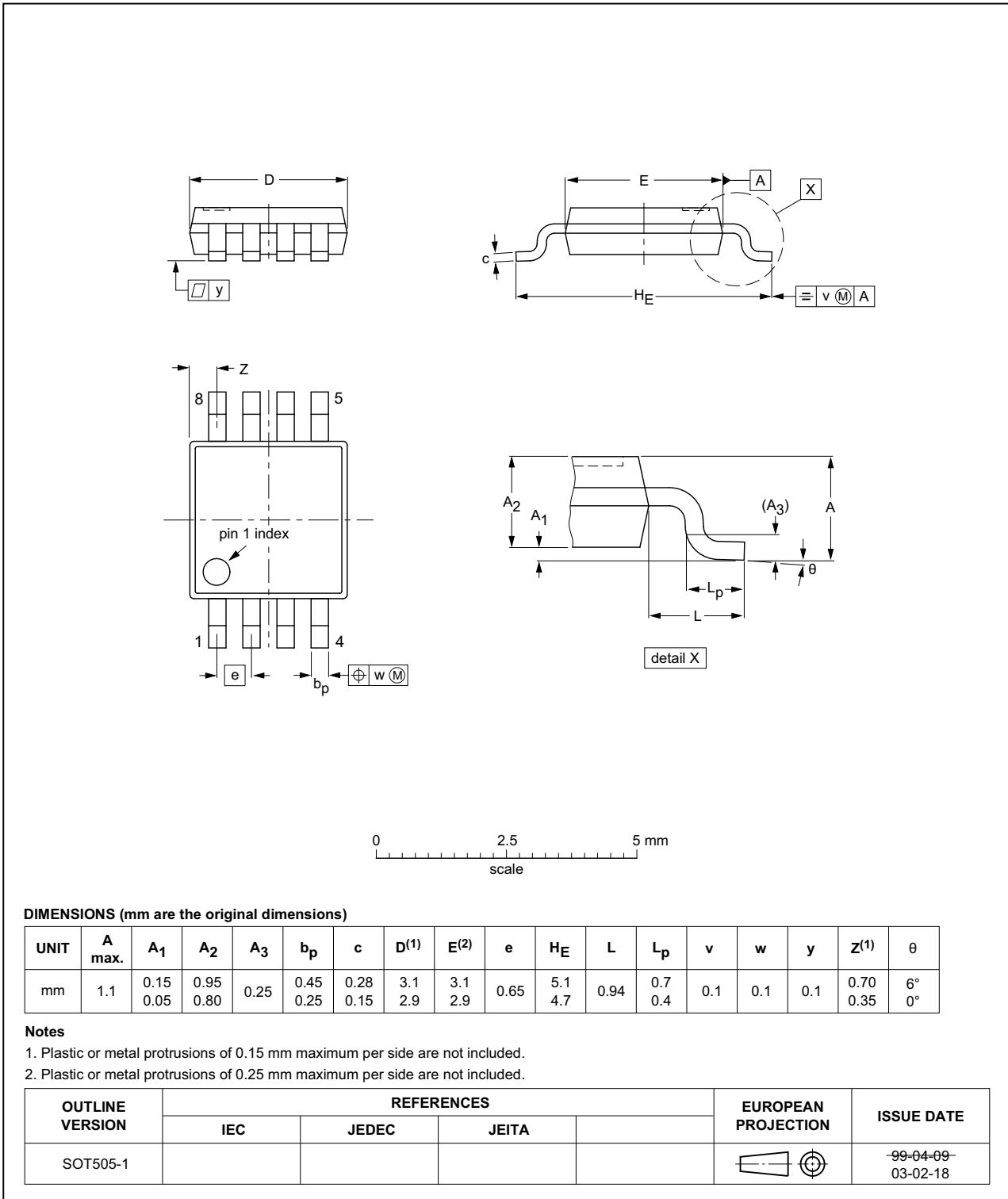

Fig 28. Package outline SOT505-1 (TSSOP8) of PCA8565TS

18. Handling information

All input and output pins are protected against ElectroStatic Discharge (ESD) under normal handling. When handling Metal-Oxide Semiconductor (MOS) devices ensure that all normal precautions are taken as described in *JESD625-A*, *IEC 61340-5* or equivalent standards.

19. Packing information

19.1 Tape and reel information

For tape and reel packing information, please see [Ref. 10 "SOT505-1_118"](#) and [Ref. 11 "SOT505-1_518" on page 42](#)

20. Soldering of SMD packages

This text provides a very brief insight into a complex technology. A more in-depth account of soldering ICs can be found in Application Note *AN10365 "Surface mount reflow soldering description"*.

20.1 Introduction to soldering

Soldering is one of the most common methods through which packages are attached to Printed Circuit Boards (PCBs), to form electrical circuits. The soldered joint provides both the mechanical and the electrical connection. There is no single soldering method that is ideal for all IC packages. Wave soldering is often preferred when through-hole and Surface Mount Devices (SMDs) are mixed on one printed wiring board; however, it is not suitable for fine pitch SMDs. Reflow soldering is ideal for the small pitches and high densities that come with increased miniaturization.

20.2 Wave and reflow soldering

Wave soldering is a joining technology in which the joints are made by solder coming from a standing wave of liquid solder. The wave soldering process is suitable for the following:

- Through-hole components
- Leaded or leadless SMDs, which are glued to the surface of the printed circuit board

Not all SMDs can be wave soldered. Packages with solder balls, and some leadless packages which have solder lands underneath the body, cannot be wave soldered. Also, leaded SMDs with leads having a pitch smaller than ~0.6 mm cannot be wave soldered, due to an increased probability of bridging.

The reflow soldering process involves applying solder paste to a board, followed by component placement and exposure to a temperature profile. Leaded packages, packages with solder balls, and leadless packages are all reflow solderable.

Key characteristics in both wave and reflow soldering are:

- Board specifications, including the board finish, solder masks and vias
- Package footprints, including solder thieves and orientation
- The moisture sensitivity level of the packages
- Package placement
- Inspection and repair
- Lead-free soldering versus SnPb soldering

20.3 Wave soldering

Key characteristics in wave soldering are:

- Process issues, such as application of adhesive and flux, clinching of leads, board transport, the solder wave parameters, and the time during which components are exposed to the wave
- Solder bath specifications, including temperature and impurities

20.4 Reflow soldering

Key characteristics in reflow soldering are:

- Lead-free versus SnPb soldering; note that a lead-free reflow process usually leads to higher minimum peak temperatures (see [Figure 29](#)) than a SnPb process, thus reducing the process window
- Solder paste printing issues including smearing, release, and adjusting the process window for a mix of large and small components on one board
- Reflow temperature profile; this profile includes preheat, reflow (in which the board is heated to the peak temperature) and cooling down. It is imperative that the peak temperature is high enough for the solder to make reliable solder joints (a solder paste characteristic). In addition, the peak temperature must be low enough that the packages and/or boards are not damaged. The peak temperature of the package depends on package thickness and volume and is classified in accordance with [Table 34](#) and [35](#)

Table 34. SnPb eutectic process (from J-STD-020D)

Package thickness (mm)	Package reflow temperature (°C)	
	Volume (mm ³)	
	< 350	≥ 350
< 2.5	235	220
≥ 2.5	220	220

Table 35. Lead-free process (from J-STD-020D)

Package thickness (mm)	Package reflow temperature (°C)		
	Volume (mm ³)		
	< 350	350 to 2000	> 2000
< 1.6	260	260	260
1.6 to 2.5	260	250	245
> 2.5	250	245	245

Moisture sensitivity precautions, as indicated on the packing, must be respected at all times.

Studies have shown that small packages reach higher temperatures during reflow soldering, see [Figure 29](#).

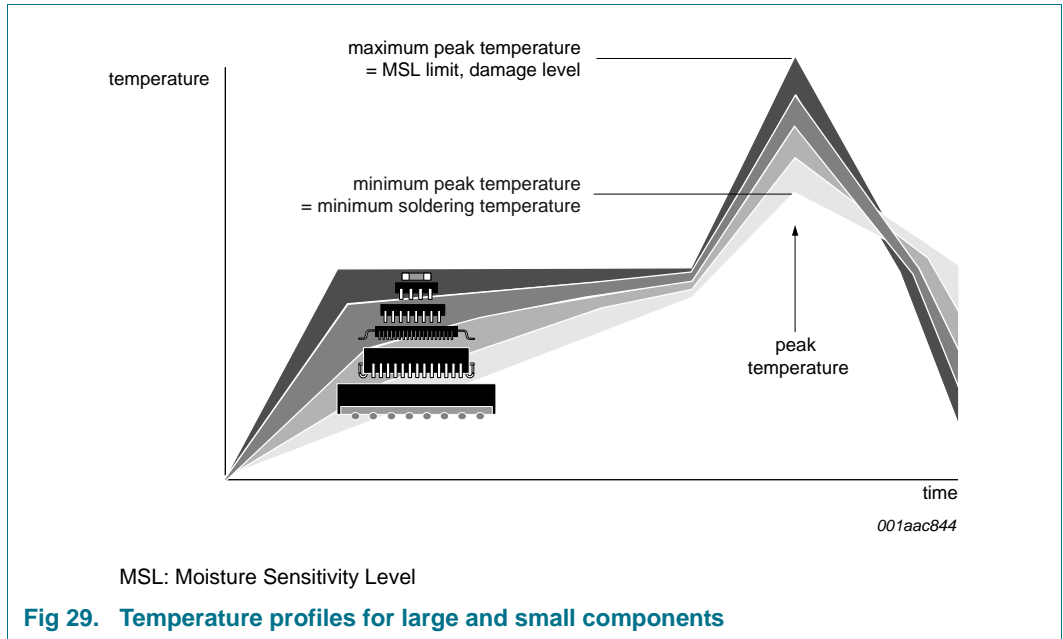

For further information on temperature profiles, refer to Application Note AN10365 "Surface mount reflow soldering description".

21. Appendix

21.1 Real-Time Clock selection

Table 36. Selection of Real-Time Clocks

Type name	Alarm, Timer, Watchdog	Interrupt output	Interface	I _{DD} , typical (nA)	Battery backup	Timestamp, tamper input	AEC-Q100 compliant	Special features
PCF8563	X	1	I ² C	250	-	-	-	-
PCF8564A	X	1	I ² C	250	-	-	-	integrated oscillator
PCA8565	X	1	I ² C	600	-	-	grade 1	high robustness, T _{amb} = -40 °C to 125 °C
PCA8565A	X	1	I ² C	600	-	-	-	integrated oscillator
PCF85063	-	1	I ² C	220	-	-	-	T _{amb} = -40 °C to 125 °C
PCF85063A	X	1	I ² C	220	-	-	-	basic functions only
PCF85063B	X	1	SPI	220	-	-	-	alarm
PCF85263A	X	2	I ² C	230	X	X	-	tiny package
PCF85263B	X	2	SPI	230	X	X	-	time stamp, battery backup, stopwatch
PCF85363A	X	2	I ² C	230	X	X	-	time stamp, battery backup, stopwatch
PCF85363B	X	2	SPI	230	X	X	-	time stamp, battery backup, stopwatch
PCF8523	X	2	I ² C	150	X	-	-	lowest power 150 nA operation, FM+ 1 M
PCF2123	X	1	SPI	100	-	-	-	lowest power 100 nA operation
PCF2127	X	1	I ² C and SPI	500	X	X	-	temperature compensated, quartz, calibrated, 512 B RAM

Table 36. Selection of Real-Time Clocks ...continued

Type name	Alarm, Timer, Watchdog	Interrupt output	Interface	I _{DD} , typical (nA)	Battery backup	Timestamp, tamper input	AEC-Q100 compliant	Special features
PCF2127A	X	1	I ² C and SPI	500	X	X	-	temperature compensated, quartz in, calibrated, 512 B RAM
PCF2129	X	1	I ² C and SPI	500	X	X	-	temperature compensated, quartz in, calibrated
PCF2129A	X	1	I ² C and SPI	500	X	X	-	temperature compensated, quartz in, calibrated
PCA2129	X	1	I ² C and SPI	500	X	X	grade 3	temperature compensated, quartz in, calibrated
PCA21125	X	1	SPI	820	-	-	grade 1	high robustness, T _{amb} = -40 °C to 125

22. Abbreviations

Table 37. Abbreviations

Acronym	Description
BCD	Binary Coded Decimal
CDM	Charged-Device Model
CMOS	Complementary Metal Oxide Semiconductor
HBM	Human Body Model
I ² C	Inter-Integrated Circuit
IC	Integrated Circuit
MSB	Most Significant Bit
MSL	Moisture Sensitivity Level
PCB	Printed-Circuit Board
POR	Power-On Reset
RC	Resistance and Capacitance
RTC	Real Time Clock
SMD	Surface Mount Device

23. References

- [1] **AN10365** — Surface mount reflow soldering description
- [2] **AN10853** — ESD and EMC sensitivity of IC
- [3] **IEC 60134** — Rating systems for electronic tubes and valves and analogous semiconductor devices
- [4] **IEC 61340-5** — Protection of electronic devices from electrostatic phenomena
- [5] **IPC/JEDEC J-STD-020D** — Moisture/Reflow Sensitivity Classification for Nonhermetic Solid State Surface Mount Devices
- [6] **JESD22-A114** — Electrostatic Discharge (ESD) Sensitivity Testing Human Body Model (HBM)
- [7] **JESD22-C101** — Field-Induced Charged-Device Model Test Method for Electrostatic-Discharge-Withstand Thresholds of Microelectronic Components
- [8] **JESD78** — IC Latch-Up Test
- [9] **JESD625-A** — Requirements for Handling Electrostatic-Discharge-Sensitive (ESDS) Devices
- [10] **SOT505-1_118** — TSSOP8; Reel pack; SMD, 13", packing information
- [11] **SOT505-1_518** — TSSOP8; Reel dry pack; SMD, 13", packing information
- [12] **UM10204** — I²C-bus specification and user manual
- [13] **UM10301** — User Manual for NXP Real Time Clocks PCF85x3, PCA8565 and PCF2123, PCA2125
- [14] **UM10569** — Store and transport requirements

24. Revision history

Table 38. Revision history

Document ID	Release date	Data sheet status	Change notice	Supersedes
PCA8565 v.4	20141205	Product data sheet	-	PCA8565 v.3
Modifications:	• Corrected Figure 27			
PCA8565 v.3	20140901	Product data sheet	-	PCA8565 v.2
PCA8565 v.2	20090616	Product data sheet	-	PCA8565 v.1
PCA8565 v.1	20030331	Product data sheet	-	-

25. Legal information

25.1 Data sheet status

Document status ^{[1][2]}	Product status ^[3]	Definition
Objective [short] data sheet	Development	This document contains data from the objective specification for product development.
Preliminary [short] data sheet	Qualification	This document contains data from the preliminary specification.
Product [short] data sheet	Production	This document contains the product specification.

[1] Please consult the most recently issued document before initiating or completing a design.

[2] The term 'short data sheet' is explained in section "Definitions".

[3] The product status of device(s) described in this document may have changed since this document was published and may differ in case of multiple devices. The latest product status information is available on the Internet at URL <http://www.nxp.com>.

25.2 Definitions

Draft — The document is a draft version only. The content is still under internal review and subject to formal approval, which may result in modifications or additions. NXP Semiconductors does not give any representations or warranties as to the accuracy or completeness of information included herein and shall have no liability for the consequences of use of such information.

Short data sheet — A short data sheet is an extract from a full data sheet with the same product type number(s) and title. A short data sheet is intended for quick reference only and should not be relied upon to contain detailed and full information. For detailed and full information see the relevant full data sheet, which is available on request via the local NXP Semiconductors sales office. In case of any inconsistency or conflict with the short data sheet, the full data sheet shall prevail.

Product specification — The information and data provided in a Product data sheet shall define the specification of the product as agreed between NXP Semiconductors and its customer, unless NXP Semiconductors and customer have explicitly agreed otherwise in writing. In no event however, shall an agreement be valid in which the NXP Semiconductors product is deemed to offer functions and qualities beyond those described in the Product data sheet.

25.3 Disclaimers

Limited warranty and liability — Information in this document is believed to be accurate and reliable. However, NXP Semiconductors does not give any representations or warranties, expressed or implied, as to the accuracy or completeness of such information and shall have no liability for the consequences of use of such information. NXP Semiconductors takes no responsibility for the content in this document if provided by an information source outside of NXP Semiconductors.

In no event shall NXP Semiconductors be liable for any indirect, incidental, punitive, special or consequential damages (including - without limitation - lost profits, lost savings, business interruption, costs related to the removal or replacement of any products or rework charges) whether or not such damages are based on tort (including negligence), warranty, breach of contract or any other legal theory.

Notwithstanding any damages that customer might incur for any reason whatsoever, NXP Semiconductors' aggregate and cumulative liability towards customer for the products described herein shall be limited in accordance with the *Terms and conditions of commercial sale* of NXP Semiconductors.

Right to make changes — NXP Semiconductors reserves the right to make changes to information published in this document, including without limitation specifications and product descriptions, at any time and without notice. This document supersedes and replaces all information supplied prior to the publication hereof.

Suitability for use in automotive applications — This NXP Semiconductors product has been qualified for use in automotive applications. Unless otherwise agreed in writing, the product is not designed, authorized or warranted to be suitable for use in life support, life-critical or safety-critical systems or equipment, nor in applications where failure or malfunction of an NXP Semiconductors product can reasonably be expected to result in personal injury, death or severe property or environmental damage. NXP Semiconductors and its suppliers accept no liability for inclusion and/or use of NXP Semiconductors products in such equipment or applications and therefore such inclusion and/or use is at the customer's own risk.

Applications — Applications that are described herein for any of these products are for illustrative purposes only. NXP Semiconductors makes no representation or warranty that such applications will be suitable for the specified use without further testing or modification.

Customers are responsible for the design and operation of their applications and products using NXP Semiconductors products, and NXP Semiconductors accepts no liability for any assistance with applications or customer product design. It is customer's sole responsibility to determine whether the NXP Semiconductors product is suitable and fit for the customer's applications and products planned, as well as for the planned application and use of customer's third party customer(s). Customers should provide appropriate design and operating safeguards to minimize the risks associated with their applications and products.

NXP Semiconductors does not accept any liability related to any default, damage, costs or problem which is based on any weakness or default in the customer's applications or products, or the application or use by customer's third party customer(s). Customer is responsible for doing all necessary testing for the customer's applications and products using NXP Semiconductors products in order to avoid a default of the applications and the products or of the application or use by customer's third party customer(s). NXP does not accept any liability in this respect.

Limiting values — Stress above one or more limiting values (as defined in the Absolute Maximum Ratings System of IEC 60134) will cause permanent damage to the device. Limiting values are stress ratings only and (proper) operation of the device at these or any other conditions above those given in the Recommended operating conditions section (if present) or the Characteristics sections of this document is not warranted. Constant or repeated exposure to limiting values will permanently and irreversibly affect the quality and reliability of the device.

Terms and conditions of commercial sale — NXP Semiconductors products are sold subject to the general terms and conditions of commercial sale, as published at <http://www.nxp.com/profile/terms>, unless otherwise agreed in a valid written individual agreement. In case an individual agreement is concluded only the terms and conditions of the respective agreement shall apply. NXP Semiconductors hereby expressly objects to applying the customer's general terms and conditions with regard to the purchase of NXP Semiconductors products by customer.

No offer to sell or license — Nothing in this document may be interpreted or construed as an offer to sell products that is open for acceptance or the grant, conveyance or implication of any license under any copyrights, patents or other industrial or intellectual property rights.

Export control — This document as well as the item(s) described herein may be subject to export control regulations. Export might require a prior authorization from competent authorities.

Translations — A non-English (translated) version of a document is for reference only. The English version shall prevail in case of any discrepancy between the translated and English versions.

25.4 Trademarks

Notice: All referenced brands, product names, service names and trademarks are the property of their respective owners.

I²C-bus — logo is a trademark of NXP Semiconductors N.V.

26. Contact information

For more information, please visit: <http://www.nxp.com>

For sales office addresses, please send an email to: salesaddresses@nxp.com

27. Tables

Table 1.	Ordering information	2
Table 2.	Ordering options	2
Table 3.	Marking codes	2
Table 4.	Pin description	4
Table 5.	Register overview and control bits default values	6
Table 6.	Register Control_1 (address 00h) bits description	7
Table 7.	Register Control_2 (address 01h) bits description	7
Table 8.	Register reset values ^[1]	8
Table 9.	Register Seconds (address 02h) bits description	9
Table 10.	Seconds coded in BCD format	9
Table 11.	Register Minutes (address 03h) bits description	10
Table 12.	Register Hours (address 04h) bits description	10
Table 13.	Register Days (address 05h) bits description	10
Table 14.	Register Weekdays (address 06h) bits description	10
Table 15.	Weekday assignments	11
Table 16.	Register Months_century (address 07h) bits description	11
Table 17.	Month assignments coded in BCD format	11
Table 18.	Register Years (08h) bits description	12
Table 19.	Register Minute_alarm (address 09h) bits description	14
Table 20.	Register Hour_alarm (address 0Ah) bits description	14
Table 21.	Register Day_alarm (address 0Bh) bits description	15
Table 22.	Register Weekday_alarm (address 0Ch) bits description	15
Table 23.	Register Timer_control (address 0Eh) bits description	16
Table 24.	Timer (address 0Fh) bits description	16
Table 25.	Timer register bits value range	16
Table 26.	Register CLKOUT_control (address 0Dh) bits description	17
Table 27.	Flag location in register Control_2	18
Table 28.	Example to clear only AF (bit 3) in register Control_2	18
Table 29.	$\overline{\text{INT}}$ operation (bit TI_TP = 1)	19
Table 30.	First increment of time circuits after STOP bit release	21
Table 31.	Limiting values	28
Table 32.	Static characteristics	29
Table 33.	Dynamic characteristics	32
Table 34.	SnPb eutectic process (from J-STD-020D)	38
Table 35.	Lead-free process (from J-STD-020D)	38
Table 36.	Selection of Real-Time Clocks	40
Table 37.	Abbreviations	42
Table 38.	Revision history	43

28. Figures

Fig 1.	Block diagram of PCA8565	3
Fig 2.	Pin configuration of PCA8565TS (TSSOP8)	4
Fig 3.	POR override sequence	9
Fig 4.	Voltage-low detection	10
Fig 5.	Data flow for the time function	12
Fig 6.	Access time for read/write operations	13
Fig 7.	Alarm function block diagram	14
Fig 8.	AF timing	17
Fig 9.	Interrupt scheme	18
Fig 10.	STOP bit functional diagram	20
Fig 11.	STOP bit release timing	20
Fig 12.	Bit transfer	22
Fig 13.	Definition of START and STOP conditions	22
Fig 14.	System configuration	23
Fig 15.	Acknowledgement on the I ² C-bus	23
Fig 16.	Slave address	24
Fig 17.	Master transmits to slave receiver (write mode)	24
Fig 18.	Master reads after setting word address (write word address; read data)	25
Fig 19.	Master reads slave immediately after first byte (read mode)	25
Fig 20.	Interface watchdog timer	26
Fig 21.	Device diode protection diagram of PCA8565	27
Fig 22.	I _{DD} as a function of V _{DD}	30
Fig 23.	I _{DD} as a function of V _{DD}	30
Fig 24.	I _{DD} as a function of temperature	31
Fig 25.	Frequency deviation as a function of V _{DD}	31
Fig 26.	I ² C-bus timing waveforms	33
Fig 27.	Application diagram of PCA8565	33
Fig 28.	Package outline SOT505-1 (TSSOP8) of PCA8565TS	35
Fig 29.	Temperature profiles for large and small components	39

29. Contents

1	General description	1	9.3	System configuration	22
2	Features and benefits	1	9.4	Acknowledge	23
3	Applications	1	9.5	I ² C-bus protocol	24
4	Ordering information	2	9.5.1	Addressing	24
4.1	Ordering options	2	9.5.2	Clock and calendar read/write cycles	24
5	Marking	2	9.5.3	Interface watchdog timer	25
6	Block diagram	3	10	Internal circuitry	27
7	Pinning information	4	11	Safety notes	27
7.1	Pinning	4	12	Limiting values	28
7.2	Pin description	4	13	Static characteristics	29
8	Functional description	5	14	Dynamic characteristics	32
8.1	Register overview	6	15	Application information	33
8.2	Control registers	7	15.1	Quartz frequency adjustment	34
8.2.1	Register Control_1	7	15.1.1	Method 1: fixed OSCI capacitor	34
8.2.2	Register Control_2	7	15.1.2	Method 2: OSCI trimmer	34
8.3	Reset	8	15.1.3	Method 3: OSCO output	34
8.3.1	Power-On Reset (POR) override	8	16	Test information	34
8.4	Time and date registers	9	16.1	Quality information	34
8.4.1	Register Seconds	9	17	Package outline	35
8.4.1.1	Voltage-low detector	9	18	Handling information	36
8.4.2	Register Minutes	10	19	Packing information	37
8.4.3	Register Hours	10	19.1	Tape and reel information	37
8.4.4	Register Days	10	20	Soldering of SMD packages	37
8.4.5	Register Weekdays	10	20.1	Introduction to soldering	37
8.4.6	Register Months_century	11	20.2	Wave and reflow soldering	37
8.4.7	Register Years	12	20.3	Wave soldering	38
8.5	Setting and reading the time	12	20.4	Reflow soldering	38
8.6	Alarm registers	13	21	Appendix	40
8.6.1	Register Minute_alarm	14	21.1	Real-Time Clock selection	40
8.6.2	Register Hour_alarm	14	22	Abbreviations	42
8.6.3	Register Day_alarm	15	23	References	42
8.6.4	Register Weekday_alarm	15	24	Revision history	43
8.7	Timer functions	15	25	Legal information	44
8.7.1	Register Timer_control	15	25.1	Data sheet status	44
8.7.2	Register Countdown_Timer	16	25.2	Definitions	44
8.8	Register CLKOUT_control and clock output	16	25.3	Disclaimers	44
8.9	Interrupt output	17	25.4	Trademarks	45
8.9.1	Bits TF and AF	17	26	Contact information	45
8.9.1.1	Clearing the alarm flag (AF)	18	27	Tables	46
8.9.2	Bits TIE and AIE	18	28	Figures	47
8.9.3	Countdown timer interrupts	19	29	Contents	48
8.10	External clock (EXT_CLK) test mode	19			
8.11	STOP bit function	20			
9	Characteristics of the I²C-bus	22			
9.1	Bit transfer	22			
9.2	START and STOP conditions	22			

Please be aware that important notices concerning this document and the product(s) described herein, have been included in section 'Legal information'.

© NXP Semiconductors N.V. 2014.

All rights reserved.

For more information, please visit: <http://www.nxp.com>

For sales office addresses, please send an email to: salesaddresses@nxp.com

Date of release: 5 December 2014

Document identifier: PCA8565





Looking for pricing, stock, or lifecycle information?

Click below to explore more details on WIN SOURCE:

 [View PCA8565TS/1,118 on WIN SOURCE](#)

 [NXP / Nexperia Information](#)

Optimize Your Supply Chain with WIN SOURCE Solutions

-  Global Sourcing Solution
-  Obsolete Management
-  Cost Control Management
-  Shortage Management
-  Alternative Solution
-  Excess Inventory Management