



**THE DATASHEET OF  
PC9RS08LA8CFT**



# Addendum for New QFN Package Migration

This addendum provides the changes to the 98A case outline numbers for products covered in this book. Case outlines were changed because of the migration from gold wire to copper wire in some packages. See the table below for the old (gold wire) package versus the new (copper wire) package.

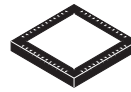
To view the new drawing, go to [Freescale.com](http://Freescale.com) and search on the new 98A package number for your device.

For more information about QFN package use, see EB806: *Electrical Connection Recommendations for the Exposed Pad on QFN and DFN Packages*.

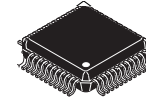
Part Number	Package Description	Original (gold wire) package document number	Current (copper wire) package document number
MC68HC908JW32	48 QFN	98ARH99048A	98ASA00466D
MC9S08AC16			
MC9S908AC60			
MC9S08AC128			
MC9S08AW60			
MC9S08GB60A			
MC9S08GT16A			
MC9S08JM16			
MC9S08JM60			
MC9S08LL16			
MC9S08QE128			
MC9S08QE32			
MC9S08RG60			
MCF51CN128			
MC9RS08LA8	48 QFN	98ARL10606D	98ASA00466D
MC9S08GT16A	32 QFN	98ARH99035A	98ASA00473D
MC9S908QE32	32 QFN	98ARE10566D	98ASA00473D
MC9S908QE8	32 QFN	98ASA00071D	98ASA00736D
MC9S08JS16	24 QFN	98ARL10608D	98ASA00734D
MC9S08QB8			
MC9S08QG8	24 QFN	98ARL10605D	98ASA00474D
MC9S08SH8	24 QFN	98ARE10714D	98ASA00474D
MC9RS08KB12	24 QFN	98ASA00087D	98ASA00602D
MC9S08QG8	16 QFN	98ARE10614D	98ASA00671D
MC9RS08KB12	8 DFN	98ARL10557D	98ASA00672D
MC9S08QG8			
MC9RS08KA2	6 DFN	98ARL10602D	98ASA00735D



## MC9RS08LA8



48 QFN  
Case 1975  
7 mm<sup>2</sup>



48 LQFP  
Case 932  
7 mm<sup>2</sup>

## MC9RS08LA8

### Features:

- 8-Bit RS08 Central Processor Unit (CPU)
  - Up to 20 MHz CPU at 2.7 V to 5.5 V across temperature range of –40°C to 85°C
  - Subset of HC08 instruction set with added BGND instruction
- On-Chip Memory
  - 8 KB flash read/program/erase over full operating voltage and temperature
  - 256-byte random-access memory (RAM)
  - Security circuitry to prevent unauthorized access to flash contents
- Power-Saving Modes
  - Wait and stop
- Clock Source Options
  - Oscillator (XOSC) — Loop-control Pierce oscillator; crystal or ceramic resonator range of 31.25 kHz to 39.0625 kHz or 1 MHz to 16 MHz
  - Internal clock source (ICS) — Internal clock source module containing a frequency-locked-loop (FLL) controlled by internal or external reference; supports bus frequencies up to 10 MHz
- System Protection
  - Watchdog computer operating properly (COP) reset with option to run from dedicated 1 kHz internal clock source or bus clock
  - Low-voltage detection with reset or interrupt; selectable trip points
  - Illegal opcode detection with reset
  - Illegal address detection with reset
  - Flash block protection
- Development Support
  - Single-wire background debug interface
  - Breakpoint capability to allow single breakpoint setting during in-circuit debugging
- Peripherals
  - **LCD** — Up to 8 × 21 or 4 × 25 segments; compatible with 5 V or 3 V LCD glass displays using on-chip charge pump; functional in wait, stop modes for very low power LCD operation; frontplane and backplane pins multiplexed with GPIO functions; selectable frontplane and backplane configurations
  - **ADC** — 6-channel, 10-bit resolution; 2.5 μs conversion time; automatic compare function; 1.7 mV/°C temperature sensor; internal bandgap reference channel; operation in stop; fully functional from 2.7 V to 5.5 V.
  - **TPM** — One 2-channel 16-bit timer/pulse-width modulator (TPM) module
  - **SCI** — One 2-channel serial communications interface module with optional 13-bit break; LIN extensions
  - **SPI** — One serial peripheral interface module in 8-bit data length mode with a receive data buffer hardware match function
  - **ACMP** — Analog comparator with option to compare to internal reference
  - **MTIM** — One 8-bit modulo timer
  - **KBI** — 8-pin keyboard interrupt module
  - **RTI** — One real-time interrupt module with optional reference clock.
- Input/Output
  - 33 GPIOs including 1 output only pin and 1 input only pin.
  - Hysteresis and configurable pullup device on all input pins; configurable slew rate and drive strength on all output pins.
- Package Options
  - 48-pin QFN
  - 48-pin LQFP

This document contains information on a product under development. Freescale reserves the right to change or discontinue this product without notice.

## Table of Contents

1	MCU Block Diagram	3	3.8.1	Control Timing	17
2	Pin Assignments	4	3.8.2	TPM/MTIM Module Timing	18
3	Electrical Characteristics	7	3.9	Analog Comparator (ACMP) Electrical	19
3.1	Parameter Classification	7	3.10	Internal Clock Source Characteristics	19
3.2	Absolute Maximum Ratings	7	3.11	ADC Characteristics	20
3.3	Thermal Characteristics	8	3.12	AC Characteristics	22
3.4	ESD Protection and Latch-Up Immunity	9	3.12.1	Control Timing	22
3.5	DC Characteristics	10	3.13	Flash Specifications	23
3.6	Supply Current Characteristics	14	4	Ordering Information	25
3.7	External (XOSC) and Internal (ICS) Oscillator Characteristics	15	5	Package Information and Mechanical Drawings	26
3.8	AC Characteristics	17			

## Revision History

To provide the most up-to-date information, the revision of our documents on the World Wide Web will be the most current. Your printed copy may be an earlier revision. To verify you have the latest information available, refer to:

<http://freescale.com/>

The following revision history table summarizes changes contained in this document.

Revision	Date	Description of Changes
1	10/9/2008	Initial public released.
2	1/30/2012	Updated the case number of 48-pin QFN to 1975; updated 48-pin QFN case outline drawing.

## Related Documentation

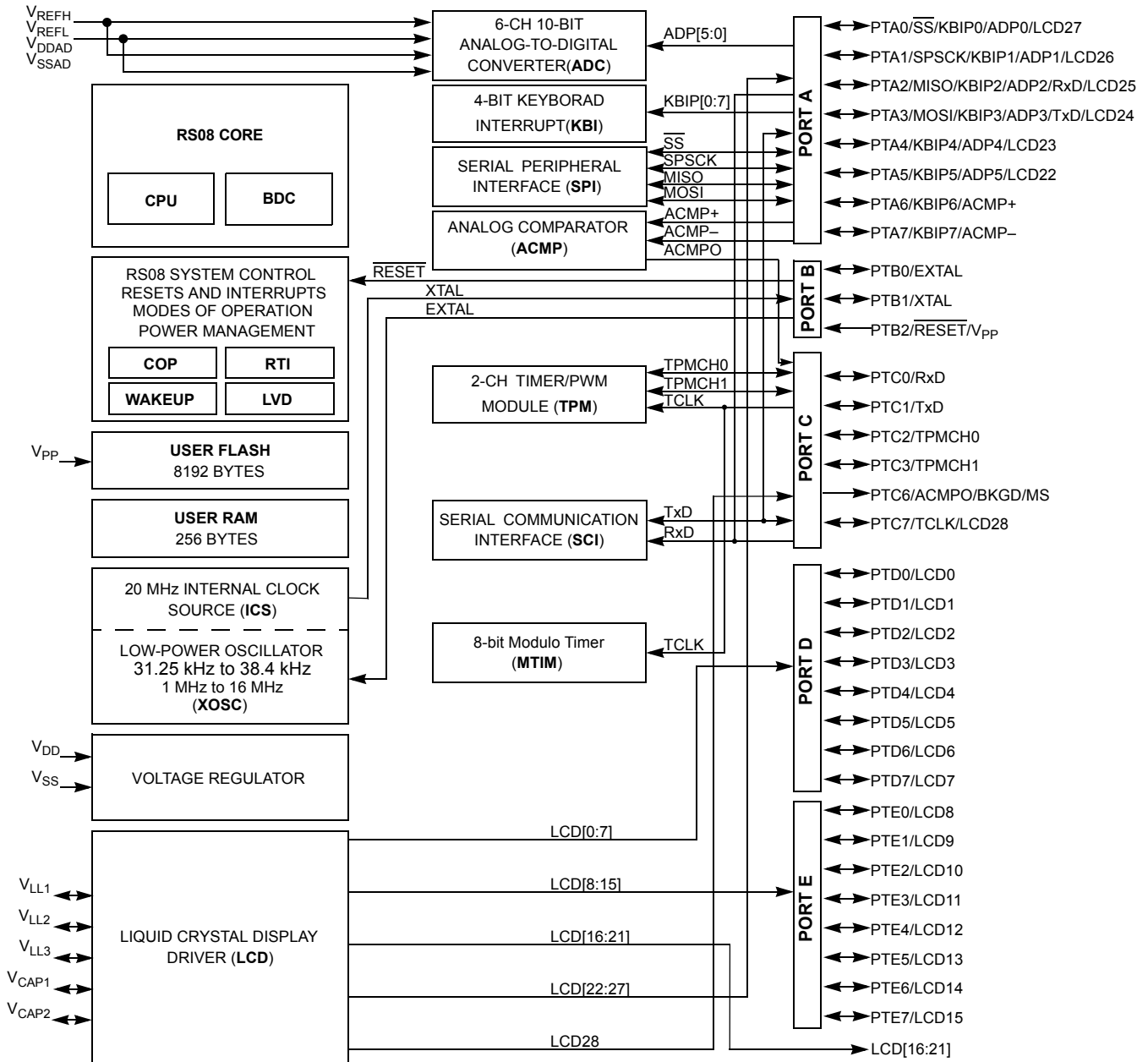
Find the most current versions of all documents at: <http://www.freescale.com>

### Reference Manual (MC9RS08LA8RM)

Contains extensive product information including modes of operation, memory, resets and interrupts, register definition, port pins, CPU, and all module information.

# 1 MCU Block Diagram

The block diagram, [Figure 1](#), shows the structure of the MC9RS08LA8 MCU.



**NOTES:**

1.  $\overline{PTB2}/\overline{RESET}/V_{PP}$  is an input only pin when used as port pin
2. PTC6/ACMPO/BKGD/MS is an output only pin

**Figure 1. MC9RS08LA8 Series Block Diagram**

## 2 Pin Assignments

This section shows the pin assignments in the packages available for the MC9RS08LA8 series.

**Table 1. Pin Availability by Package Pin-Count**

Pin Number	<-- Lowest Priority --> Highest					
48	Port Pin	Alt 1	Alt 2	Alt 3	Alt 4	Alt 5
1	PTD7					LCD7
2	PTD6					LCD6
3	PTD5					LCD5
4	PTD4					LCD4
5	PTD3					LCD3
6	PTD2					LCD2
7	PTD1					LCD1
8	PTD0					LCD0
9						V <sub>CAP1</sub>
10						V <sub>CAP2</sub>
11						V <sub>LL1</sub>
12						V <sub>LL2</sub>
13						V <sub>LL3</sub>
14	PTA6	KBIP6	ACMP+			
15	PTA7	KBIP7	ACMP-			
16				V <sub>SSAD</sub> /V <sub>REFL</sub>		
17				V <sub>DDAD</sub> /V <sub>REFH</sub>		
18	PTB0			EXTAL		
19	PTB1			XTAL		
20				V <sub>DD</sub>		
21				V <sub>SS</sub>		
22	PTB2		RESET	V <sub>PP</sub>		
23	PTC0		RxD			
24	PTC1		TxD			
25	PTC2		TPMCH0			
26	PTC3		TPMCH1			
27	PTC6	ACMPO	BKGD	MS		
28	PTC7		TCLK			LCD28
29	PTA0	SS	KBIP0	ADP0		LCD27
30	PTA1	SPSCK	KBIP1	ADP1		LCD26
31	PTA2	MISO	KBIP2	RxD	ADP2	LCD25

**Table 1. Pin Availability by Package Pin-Count (continued)**

Pin Number	<-- Lowest Priority --> Highest					
	Port Pin	Alt 1	Alt 2	Alt 3	Alt 4	Alt 5
32	PTA3	MOSI	KBIP3	TxD	ADP3	LCD24
33	PTA4		KBIP4	ADP4		LCD23
34	PTA5		KBIP5	ADP5		LCD22
35						LCD21
36						LCD20
37						LCD19
38						LCD18
39						LCD17
40						LCD16
41	PTE7					LCD15
42	PTE6					LCD14
43	PTE5					LCD13
44	PTE4					LCD12
45	PTE3					LCD11
46	PTE2					LCD10
47	PTE1					LCD9
48	PTE0					LCD8

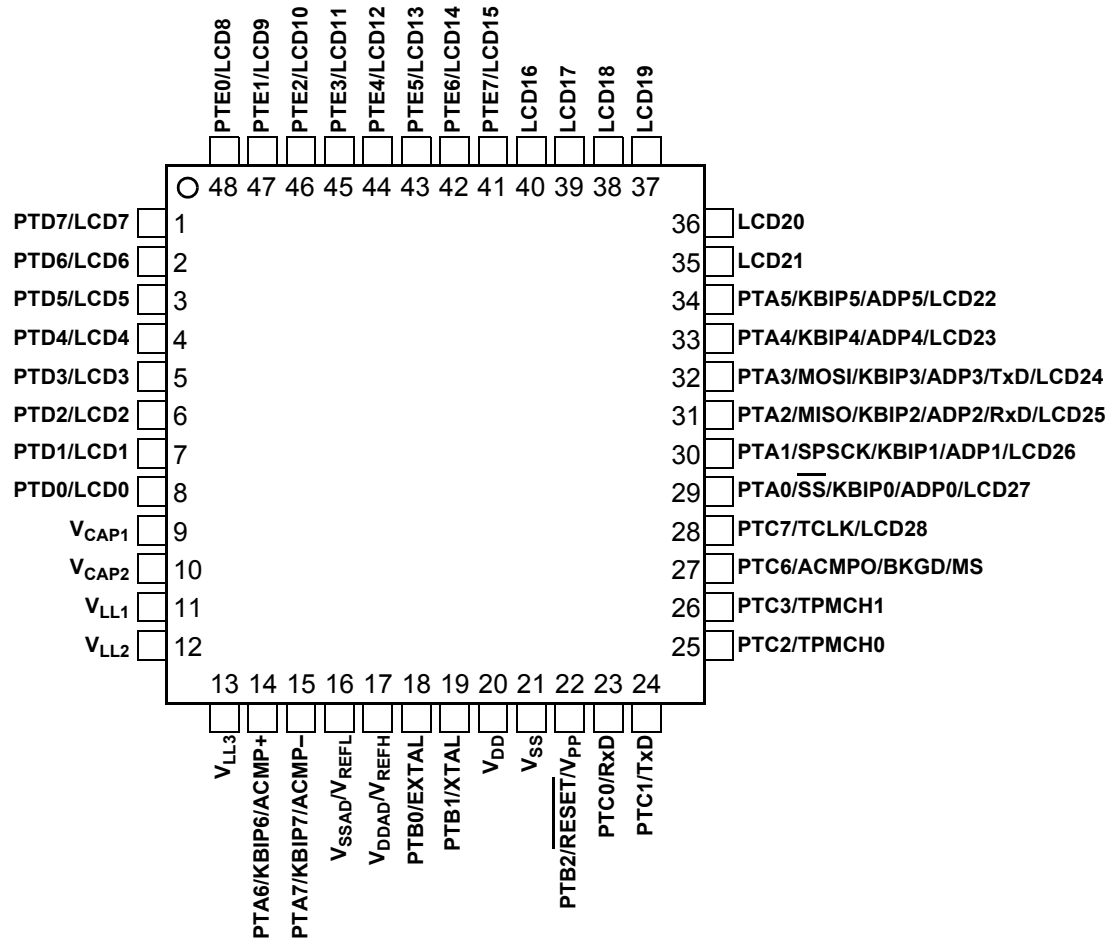


Figure 2. MC9RS08LA8 Series in 48-Pin QFN/LQFP Package

## 3 Electrical Characteristics

This chapter contains electrical and timing specifications.

### 3.1 Parameter Classification

The electrical parameters shown in this supplement are guaranteed by various methods. To give the customer a better understanding the following classification is used and the parameters are tagged accordingly in the tables where appropriate:

**Table 2. Parameter Classifications**

<b>P</b>	Those parameters are guaranteed during production testing on each individual device.
<b>C</b>	Those parameters are achieved by the design characterization by measuring a statistically relevant sample size across process variations.
<b>T</b>	Those parameters are achieved by design characterization on a small sample size from typical devices under typical conditions unless otherwise noted. All values shown in the typical column are within this category.
<b>D</b>	Those parameters are derived mainly from simulations.

#### NOTE

The classification is shown in the column labeled “C” in the parameter tables where appropriate.

### 3.2 Absolute Maximum Ratings

Absolute maximum ratings are stress ratings only, and functional operation at the maxima is not guaranteed. Stress beyond the limits specified in [Table 3](#) may affect device reliability or cause permanent damage to the device. For functional operating conditions, refer to the remaining tables in this chapter.

This device contains circuitry protecting against damage due to high static voltage or electrical fields; however, it is advised that normal precautions be taken to avoid application of any voltages higher than maximum-rated voltages to this high-impedance circuit. Reliability of operation is enhanced if unused inputs are tied to an appropriate logic voltage level (for instance, either  $V_{SS}$  or  $V_{DD}$ ) or the programmable pull-up resistor associated with the pin is enabled.

**Table 3. Absolute Maximum Ratings**

Rating	Symbol	Value	Unit
Supply voltage	$V_{DD}$	2.7 to 5.5	V
Maximum current into $V_{DD}$	$I_{DD}$	120	mA
Digital input voltage	$V_{In}$	-0.3 to $V_{DD} + 0.3$	V
Instantaneous maximum current Single pin limit (applies to all port pins) <sup>1, 2, 3</sup>	$I_D$	±25	mA
Storage temperature range	$T_{stg}$	-55 to 150	°C

## Electrical Characteristics

- <sup>1</sup> Input must be current limited to the value specified. To determine the value of the required current-limiting resistor, calculate resistance values for positive ( $V_{DD}$ ) and negative ( $V_{SS}$ ) clamp voltages, then use the larger of the two resistance values.
- <sup>2</sup> All functional non-supply pins are internally clamped to  $V_{SS}$  and  $V_{DD}$  except the  $\overline{\text{RESET}}/V_{PP}$  pin which is internally clamped to  $V_{SS}$  only.
- <sup>3</sup> Power supply must maintain regulation within operating  $V_{DD}$  range during instantaneous and operating maximum current conditions. If positive injection current ( $V_{in} > V_{DD}$ ) is greater than  $I_{DD}$ , the injection current may flow out of  $V_{DD}$  and could result in external power supply going out of regulation. Ensure external  $V_{DD}$  load will shunt current greater than maximum injection current. This will be the greatest risk when the MCU is not consuming power. Examples are: if no system clock is present, or if the clock rate is very low which would reduce overall power consumption.

## 3.3 Thermal Characteristics

This section provides information about operating temperature range, power dissipation, and package thermal resistance. Power dissipation on I/O pins is usually small compared to the power dissipation in on-chip logic and voltage regulator circuits and it is user-determined rather than being controlled by the MCU design. In order to take  $P_{I/O}$  into account in power calculations, determine the difference between actual pin voltage and  $V_{SS}$  or  $V_{DD}$  and multiply by the pin current for each I/O pin. Except in cases of unusually high pin current (heavy loads), the difference between pin voltage and  $V_{SS}$  or  $V_{DD}$  will be very small.

**Table 4. Thermal Characteristics**

Rating	Symbol	Value	Unit
Operating temperature range (packaged)	$T_A$	$T_L$ to $T_H$ -40 to 85	°C
Maximum junction temperature	$T_{JMAX}$	105	°C
Thermal resistance Single layer board	$\theta_{JA}$	71	°C/W
48-pin LQFP		84	
48-pin QFN			
Four layer board			
		49	
		28	

The average chip-junction temperature ( $T_J$ ) in °C can be obtained from:

$$T_J = T_A + (P_D \times \theta_{JA}) \quad \text{Eqn. 1}$$

where:

$T_A$  = Ambient temperature, °C

$\theta_{JA}$  = Package thermal resistance, junction-to-ambient, °C /W

$P_D = P_{int} + P_{I/O}$

$P_{int} = I_{DD} \times V_{DD}$ , Watts chip internal power

$P_{I/O}$  = Power dissipation on input and output pins user determined

For most applications,  $P_{I/O} \ll P_{int}$  and can be neglected. An approximate relationship between  $P_D$  and  $T_J$

(if PI/O is neglected) is:

$$P_D = K \div (T_J + 273^\circ\text{C}) \quad \text{Eqn. 2}$$

Solving Equation 1 and Equation 2 for K gives:

$$K = P_D \times (T_A + 273^\circ\text{C}) + \theta_{JA} \times (P_D)^2 \quad \text{Eqn. 3}$$

where K is a constant pertaining to the particular part. K can be determined from Equation A-3 by measuring  $P_D$  (at equilibrium) for a known  $T_A$ . Using this value of K, the values of  $P_D$  and  $T_J$  can be obtained by solving equations 1 and 2 iteratively for any value of  $T_A$ .

### 3.4 ESD Protection and Latch-Up Immunity

Although damage from electrostatic discharge (ESD) is much less common on these devices than on early CMOS circuits, normal handling precautions must be used to avoid exposure to static discharge. Qualification tests are performed to ensure that these devices can withstand exposure to reasonable levels of static without suffering any permanent damage.

All ESD testing is in conformity with AEC-Q100 Stress Test Qualification for Automotive Grade Integrated Circuits. During the device qualification ESD stresses were performed for the human body model (HBM), the machine model (MM) and the charge device model (CDM).

A device is defined as a failure if after exposure to ESD pulses the device no longer meets the device specification. Complete DC parametric and functional testing is performed per the applicable device specification at room temperature followed by hot temperature, unless specified otherwise in the device specification.

**Table 5. ESD and Latch-up Test Conditions**

Model	Description	Symbol	Value	Unit
Human Body	Series resistance	R1	1500	$\Omega$
	Storage capacitance	C	100	pF
	Number of pulses per pin	—	3	—
Machine	Series resistance	R1	0	$\Omega$
	Storage capacitance	C	200	pF
	Number of pulses per pin	—	3	—
Latch-up	Minimum input voltage limit	—	-2.5	V
	Maximum input voltage limit	—	7.5	V

**Table 6. ESD and Latch-Up Protection Characteristics**

No.	Rating <sup>1</sup>	Symbol	Min	Max	Unit
1	Human body model (HBM)	$V_{HBM}$	$\pm 2000$	—	V
2	Machine model (MM)	$V_{MM}$	$\pm 200$	—	V
3	Charge device model (CDM)	$V_{CDM}$	$\pm 500$	—	V
4	Latch-up current at $T_A = 85^\circ\text{C}$	$I_{LAT}$	$\pm 100^2$	—	mA
	Latch-up current at $T_A = 85^\circ\text{C}$	$I_{LAT}$	$\pm 75^3$	—	mA

<sup>1</sup> Parameter is achieved by design characterization on a small sample size from typical devices under typical conditions unless otherwise noted.

<sup>2</sup> These pins meet JESD78A Class II (section 1.2) Level A (section 1.3) requirement of  $\pm 100$  mA.

<sup>3</sup> This pin meets JESD78A Class II (section 1.2) Level B (section 1.3) characterization to  $\pm 75$  mA.

### 3.5 DC Characteristics

This section includes information about power supply requirements, I/O pin characteristics, and power supply current in various operating modes.

**Table 7. DC Characteristics (Temperature Range =  $-40$  to  $85^\circ\text{C}$  Ambient)**

Num	C	Parameter	Symbol	Min	Typical	Max	Unit
1	P	Supply voltage (run, wait and stop modes) $0 < f_{BUS} < 10$ MHz	$V_{DD}$	2.7	—	5.5	V
2	D	Minimum RAM retention supply voltage applied to $V_{DD}$	$V_{RAM}$	$0.8^1$	—	—	V
3	P	Low-voltage Detection threshold ( $V_{DD}$ falling)	$V_{LVD}$	—	1.8	—	V
4	C	Power on RESET (POR) voltage	$V_{POR}$	0.9	1.4	1.7	V
5	P	Input high voltage ( $V_{DD} > 5$ V) (all digital inputs)	$V_{IH}$	$0.70 \times V_{DD}$	—	—	V
6	P	Input high voltage ( $2.7 \text{ V} \leq V_{DD} \leq 5 \text{ V}$ ) (all digital inputs)	$V_{IH}$	$0.85 \times V_{DD}$	—	—	V
7	P	Input low voltage ( $V_{DD} > 5 \text{ V}$ ) (all digital inputs)	$V_{IL}$	—	—	$0.30 \times V_{DD}$	V
8	P	Input low voltage ( $2.7 \text{ V} \leq V_{DD} \leq 5 \text{ V}$ ) (all digital inputs)	$V_{IL}$	—	—	$0.30 \times V_{DD}$	V
9	C	Input hysteresis (all digital inputs)	$V_{hys}$	$0.06 \times V_{DD}$	—	—	V
10	P	Input leakage current (per pin) $V_{In} = V_{DD}$ or $V_{SS}$ , all input only pins	$ I_{In} $	—	0.025	1.0	$\mu\text{A}$
11	P	High impedance (off-state) leakage current (per pin) $V_{In} = V_{DD}$ or $V_{SS}$ , all input/output	$ I_{OZ} $	—	0.025	1.0	$\mu\text{A}$
12	C	Internal pullup/pulldown resistors <sup>2</sup> (all port pins)	$R_{PU}$	20	45	65	$\text{k}\Omega$
13	P	Output high voltage (all ports) <sup>3,4</sup> $I_{OH} = -5 \text{ mA}$ ( $V_{DD} \geq 4.5 \text{ V}$ ) $I_{OH} = -3 \text{ mA}$ ( $V_{DD} \geq 3 \text{ V}$ )	$V_{OH}$	$V_{DD} - 0.8$	—	—	V
14	C	Maximum total $I_{OH}$ for all port pins	$ I_{OHT} $	—	—	100	mA

**Table 7. DC Characteristics (Temperature Range = -40 to 85°C Ambient) (continued)**

Num	C	Parameter	Symbol	Min	Typical	Max	Unit
15	P	Output low voltage (port A) <sup>4</sup> $I_{OL} = 5 \text{ mA}$ ( $V_{DD} \geq 4.5 \text{ V}$ ) $I_{OL} = 3 \text{ mA}$ ( $V_{DD} \geq 3 \text{ V}$ )	$V_{OL}$	—	—	0.8 0.8	V
16	C	Maximum total IOL for all port pins	$I_{OLT}$	—	—	100	mA
17	C	dc injection current <sup>5,6,7</sup> $V_{In} < V_{SS}$ , $V_{In} > V_{DD}$ Single pin limit Total MCU limit, includes sum of all stressed pins		— —	— —	0.2 0.8	mA mA
18	C	Input capacitance (all non-supply pins)	$C_{In}$	—	—	7	pF

<sup>1</sup> This parameter is characterized and not tested on each device.

<sup>2</sup> Measurement condition for pull resistors:  $V_{In} = V_{SS}$  for pullup and  $V_{In} = V_{DD}$  for pulldown.

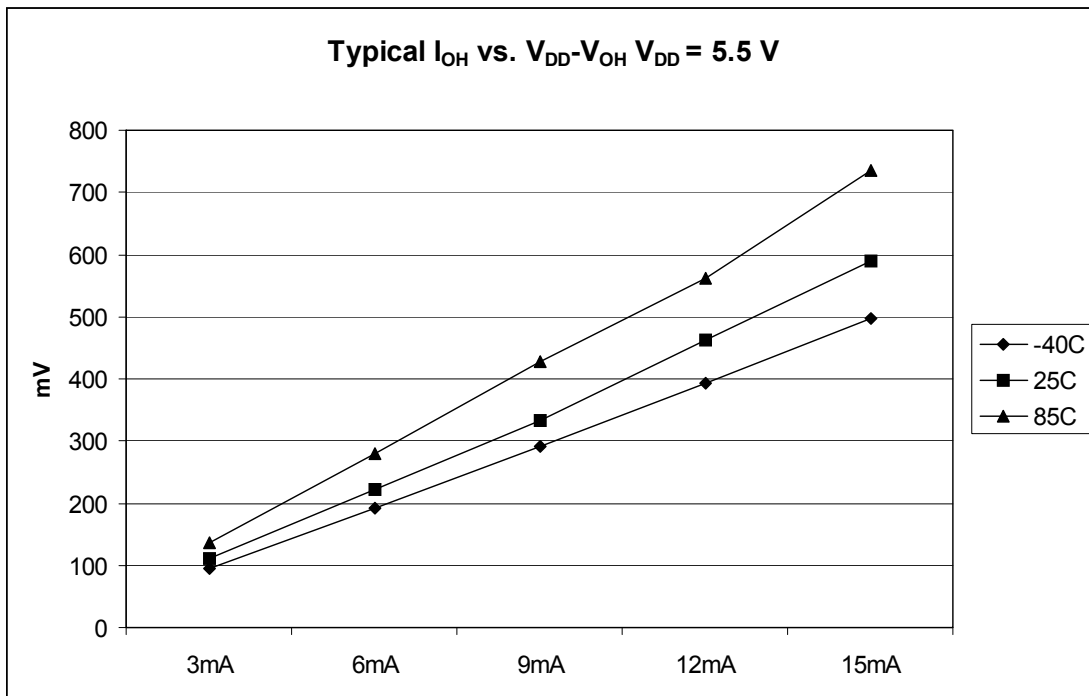
<sup>3</sup> The  $I_{OH}$  is for high output drive strength.

<sup>4</sup> It is tested under high output drive strength only.

<sup>5</sup> All functional non-supply pins are internally clamped to  $V_{SS}$  and  $V_{DD}$  except the  $\overline{\text{RESET}}/V_{PP}$  which is internally clamped to  $V_{SS}$  only

<sup>6</sup> Input must be current limited to the value specified. To determine the value of the required current-limiting resistor, calculate resistance values for positive and negative clamp voltages, then use the larger of the two values.

<sup>7</sup> This parameter is characterized and not tested on each device.


**Figure 3. Typical  $I_{OH}$  vs.  $V_{DD}-V_{OH}$  ( $V_{DD} = 5.5 \text{ V}$ )**

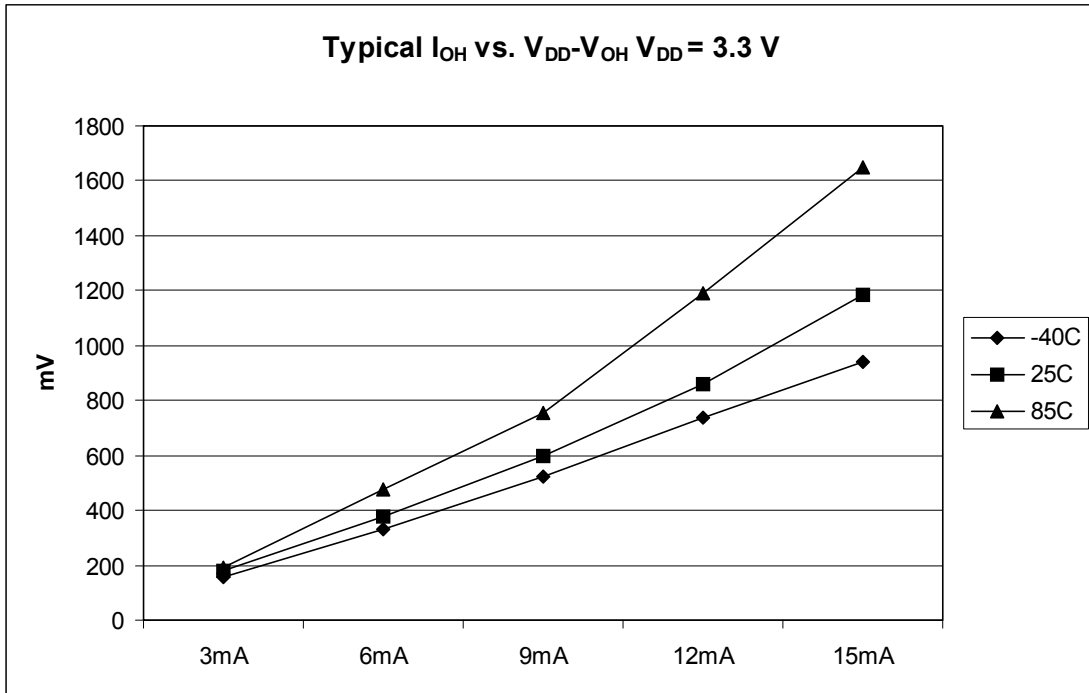


Figure 4. Typical  $I_{OH}$  vs.  $V_{DD}-V_{OH}$  ( $V_{DD} = 3.3\text{ V}$ )

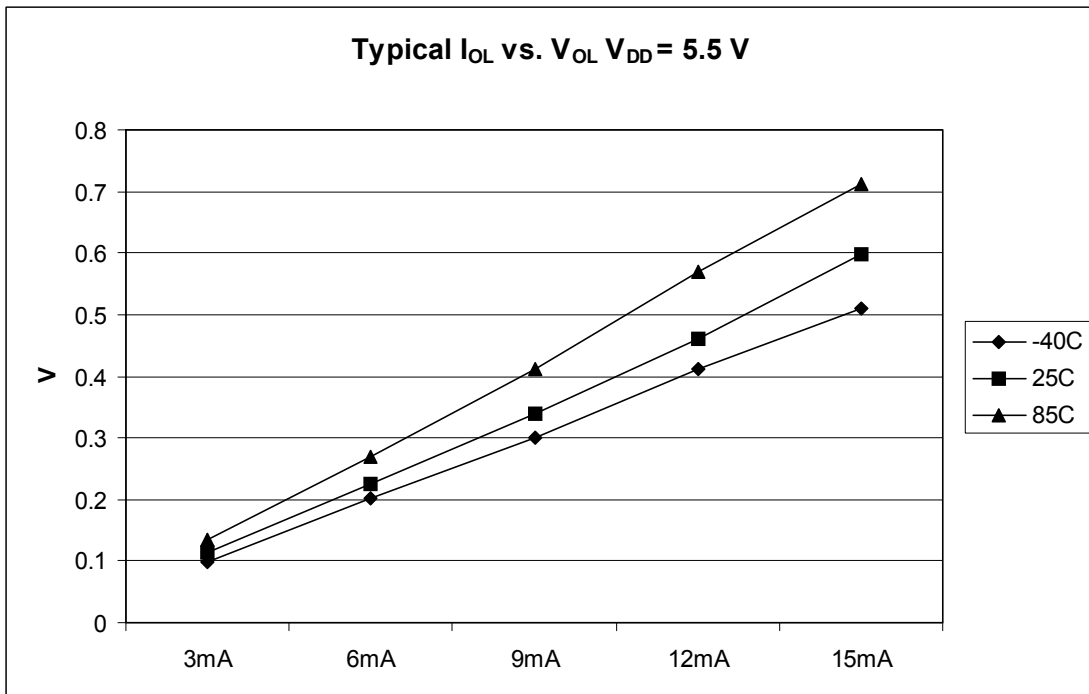


Figure 5. Typical  $I_{OL}$  vs.  $V_{OL}$  ( $V_{DD} = 5.5\text{ V}$ )

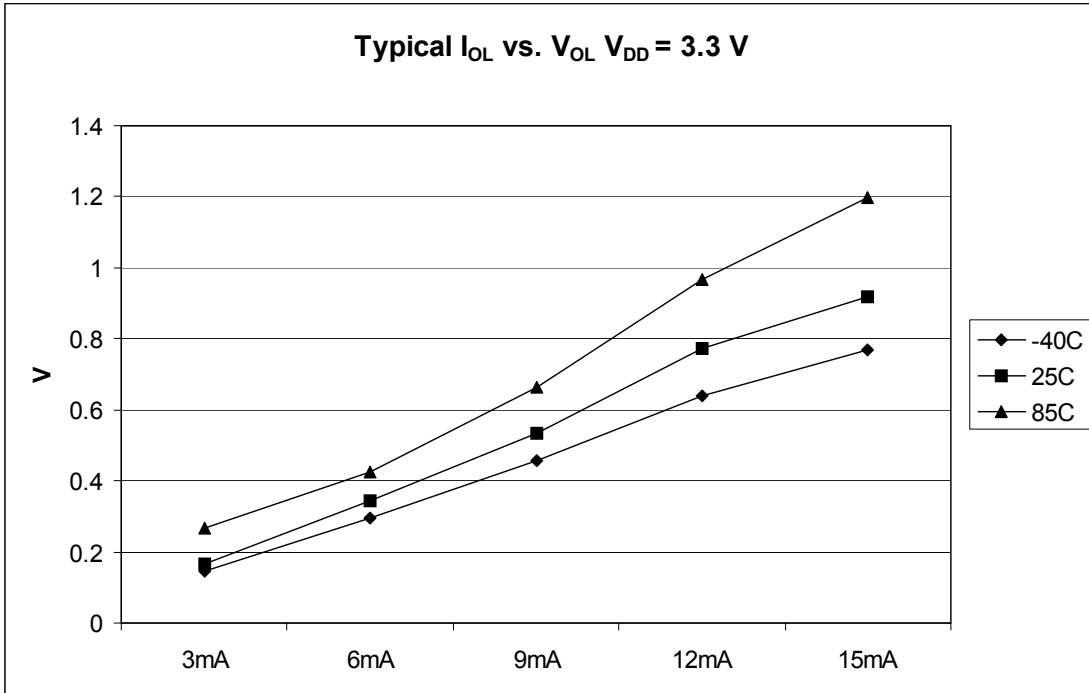


Figure 6. Typical  $I_{OL}$  vs.  $V_{OL}$  ( $V_{DD} = 3.3$  V)

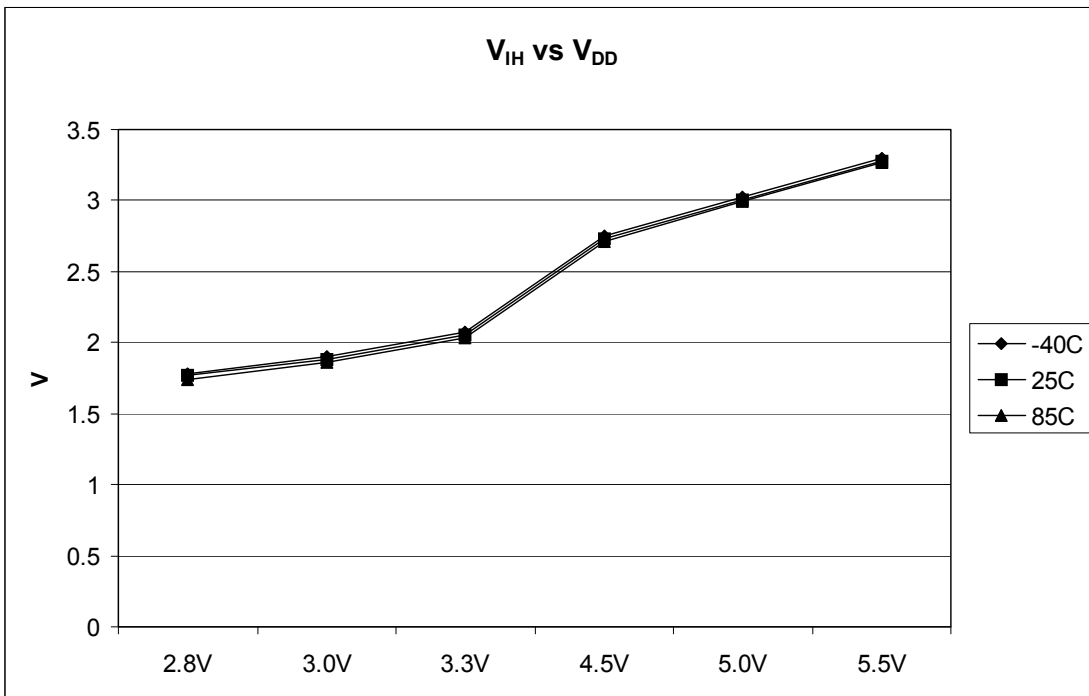


Figure 7. Typical  $V_{DD}$  vs.  $V_{IH}$

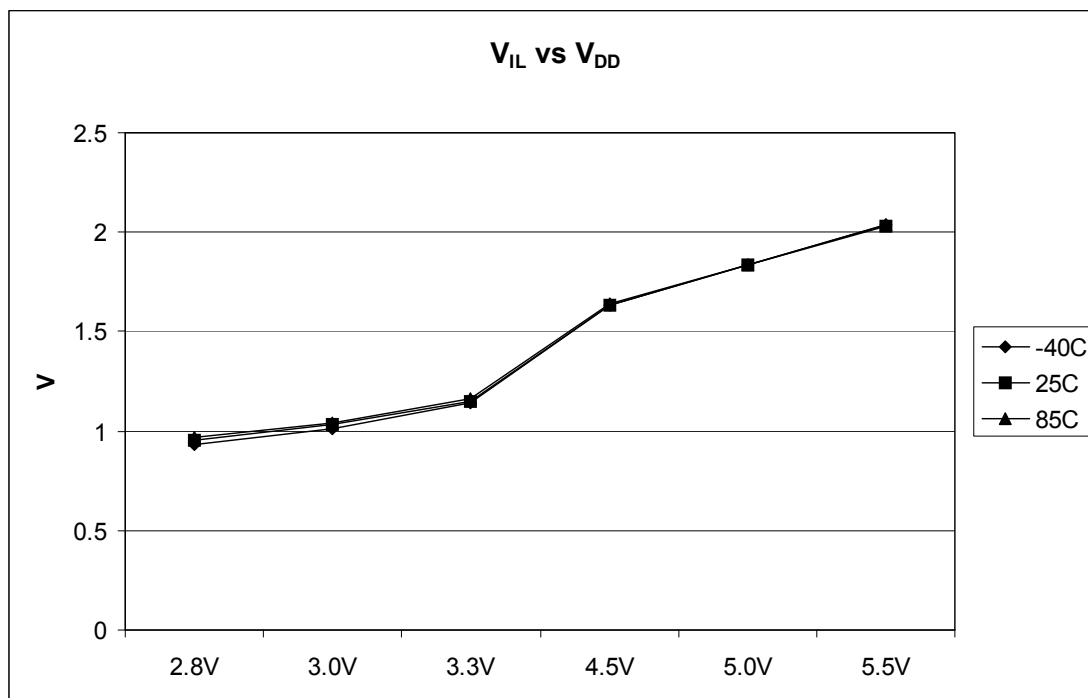


Figure 8. Typical  $V_{DD}$  vs.  $V_{IL}$

### 3.6 Supply Current Characteristics

Table 8. Supply Current Characteristics

Num	C	Parameter	Symbol	$V_{DD}$ (V)	Typical <sup>1</sup>	Unit
1	P	Run supply current <sup>2</sup> measured at ( $f_{Bus} = 10$ MHz)	$R_{I_{DD10}}$	5	3.71	mA
				3.3	3.68	mA
				3	3.67	mA
				2.7	3.66	mA
2	P	Wait mode supply current	$W_{I_{DD1}}$	5	1.37	mA
				3.3	1.37	mA
				3	1.37	mA
				2.7	1.36	mA
3	P	Stop mode supply current	$S_{I_{DD}}$	5	1.40	$\mu$ A
				3.3	1.35	$\mu$ A
				3	1.31	$\mu$ A
				2.7	1.25	$\mu$ A
4	C	ADC adder from stop <sup>3</sup>	—	5	125.45	$\mu$ A
				3.3	122.04	$\mu$ A
				3	121.59	$\mu$ A
				2.7	121.22	$\mu$ A
5	C	ACMP adder from stop (ACME = 1)	—	5	21	$\mu$ A
				3	18.5	$\mu$ A

**Table 8. Supply Current Characteristics (continued)**

Num	C	Parameter	Symbol	V <sub>DD</sub> (V)	Typical <sup>1</sup>	Unit
6	C	RTI adder from stop with 1 kHz clock source enabled <sup>4</sup>	—	5	2.4	μA
				3	1.9	μA
8	C	LVI adder from stop (LVDE = 1 and LVDSE = 1)	—	5	70	μA
				3	65	μA

<sup>1</sup> Typicals are measured at 25 °C.

<sup>2</sup> Does not include any dc loads on port pins

<sup>3</sup> Required asynchronous ADC clock and LVD to be enabled.

<sup>4</sup> Most customers are expected to find that auto-wakeup from stop can be used instead of the higher current wait mode. Wait mode typical is 1.37 mA at 5 V and 3 V with  $f_{BUS} = 10$  MHz.

### 3.7 External (XOSC) and Internal (ICS) Oscillator Characteristics

Reference [Figure 9](#) for crystal or resonator circuit.

**Table 9. External Oscillator Specifications (Temperature Range = –40 to 85°C Ambient)**

Characteristic	Symbol	Min	Typical <sup>1</sup>	Max	Unit
Oscillator crystal or resonator (EREFS = 1)					
Low range, (IREFS = x)	$f_{lo}$	32	—	38.4	kHz
High range, FLL bypassed external (CLKS = 10, IREFS = x)	$f_{hi\_byp}$	1	—	10	MHz
High range, FLL engaged external (CLKS = 00, IREFS = 0)	$f_{hi\_eng}$	1	—	10	MHz
Load capacitors	$C_1$ $C_2$	See Note <sup>2</sup>			
Feedback resistor					
Low range (32 kHz to 100 kHz)	$R_F$		10		M $\Omega$
High range (1 MHz to 16 MHz)			1		M $\Omega$
Series resistor					
Low range					
Low Gain (HGO = 0)		—	0	—	
High Gain (HGO = 1)		—	100	—	
High range					
Low Gain (HGO = 0)	$R_S$	—	0	—	k $\Omega$
High Gain (HGO = 1)					
≥ 8 MHz		—	0	—	
4 MHz		—	10	—	
1 MHz		—	20	—	
Crystal start-up time <sup>3, 4</sup>					
Low range	$t_{CSTL}$	—	500	—	ms
High range	$t_{CSTH}$	—	4	—	
Square wave input clock frequency (EREFS = 0)					
FLL bypass external (CLKS = 10)	$f_{extal}$	0	—	20	MHz
FLL engaged external (CLKS = 00)		0.03125	—	5	
Average internal reference frequency - untrimmed	$f_{int\_ut}$	25	31.25	41.66	kHz
Average internal reference frequency - trimmed	$f_{int\_t}$	31.25	31.25	39.0625	kHz
DCO output frequency range - untrimmed	$f_{dco\_ut}$	12.8	16	21.33	MHz
DCO output frequency range - trimmed	$f_{dco\_t}$	16	16	20	MHz
Resolution of trimmed DCO output frequency at fixed voltage and temperature	$\Delta f_{dco\_res\_t}$	—	—	±0.2	% $f_{dco}$
Total deviation of trimmed DCO output frequency over voltage and temperature	$\Delta f_{dco\_t}$	—	—	±2	% $f_{dco}$
FLL acquisition time <sup>3,5</sup>	$t_{acquire}$	—	—	1	ms
Long term Jitter <sup>6</sup> of DCO output clock (averaged over 2ms interval)	$C_{jitter}$	—	—	0.6	% $f_{dco}$

<sup>1</sup> Data in Typical column was characterized at 3.0 V, 25 °C or is typical recommended value.

<sup>2</sup> See crystal or resonator manufacturer's recommendation.

<sup>3</sup> This parameter is characterized and not tested on each device.

<sup>4</sup> Proper PC board layout procedures must be followed to achieve specifications.

<sup>5</sup> This specification applies to any time the FLL reference source or reference divider is changed, trim value changed or changing from FLL disabled (FBELP, FBILP) to FLL enabled (FEI, FEE, FBE, FBI). If a crystal/resonator is being used as the reference, this specification assumes it is already running.

<sup>6</sup> Jitter is the average deviation from the programmed frequency measured over the specified interval at maximum  $f_{BUS}$ . Measurements are made with the device powered by filtered supplies and clocked by a stable external clock signal. Noise injected into the FLL circuitry via  $V_{DD}$  and  $V_{SS}$  and variation in crystal oscillator frequency increase the  $C_{Jitter}$  percentage for a given interval.

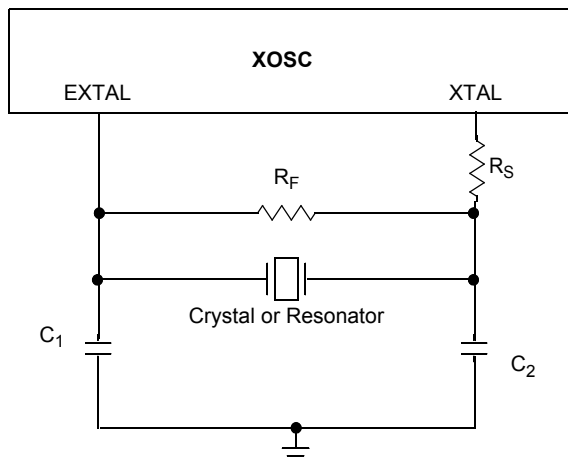


Figure 9. Typical Crystal or Resonator Circuit

### 3.8 AC Characteristics

This section describes ac timing characteristics for each peripheral system.

#### 3.8.1 Control Timing

Table 10. Control Timing

Parameter	Symbol	Min	Typical	Max	Unit
Bus frequency ( $t_{cyc} = 1/f_{BUS}$ )	$f_{BUS}$	0	—	10	MHz
Real time interrupt internal oscillator period	$t_{RTI}$	700	1000	1300	$\mu s$
External RESET pulse width <sup>1</sup>	$t_{extrst}$	150	—	—	ns
KBI pulse width <sup>2</sup>	$t_{KBIPW}$	$1.5 t_{cyc}$	—	—	ns
KBI pulse width in stop <sup>1</sup>	$t_{KBIPWS}$	100	—	—	ns
Port rise and fall time (load = 50 pF) <sup>3</sup> Slew rate control disabled (PTxSE = 0) Slew rate control enabled (PTxSE = 1)	$t_{Rise}, t_{Fall}$	—	11 35	—	ns

<sup>1</sup> This is the shortest pulse that is guaranteed to pass through the pin input filter circuitry. Shorter pulses may or may not be recognized.

<sup>2</sup> This is the minimum pulse width that is guaranteed to pass through the pin synchronization circuitry. Shorter pulses may or may not be recognized. In stop mode, the synchronizer is bypassed so shorter pulses can be recognized in that case.

<sup>3</sup> Timing is shown with respect to 20%  $V_{DD}$  and 80%  $V_{DD}$  levels. Temperature range  $-40^{\circ}C$  to  $85^{\circ}C$ .

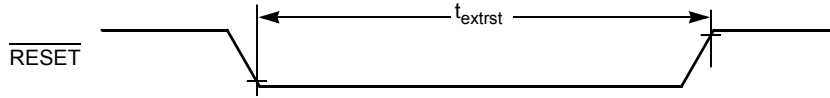


Figure 10. Reset Timing

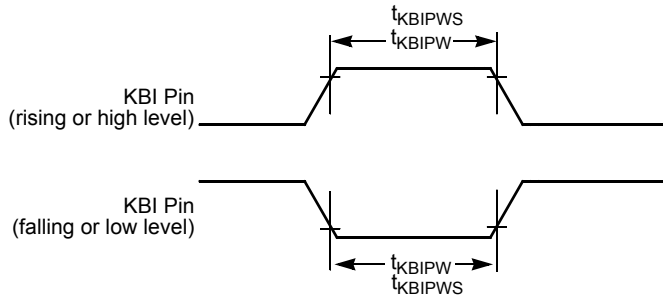


Figure 11. KBI Pulse Width

### 3.8.2 TPM/MTIM Module Timing

Synchronizer circuits determine the shortest input pulses that can be recognized or the fastest clock that can be used as the optional external source to the timer counter. These synchronizers operate from the current bus rate clock.

Table 11. TPM/MTIM Input Timing

Function	Symbol	Min	Max	Unit
External clock frequency	$f_{TCLK}$	0	$f_{BUS}/4$	MHz
External clock period	$t_{TCLK}$	4	—	$t_{CYC}$
External clock high time	$t_{clkh}$	1.5	—	$t_{CYC}$
External clock low time	$t_{clkl}$	1.5	—	$t_{CYC}$
Input capture pulse width	$f_{ICPW}$	1.5	—	$t_{CYC}$

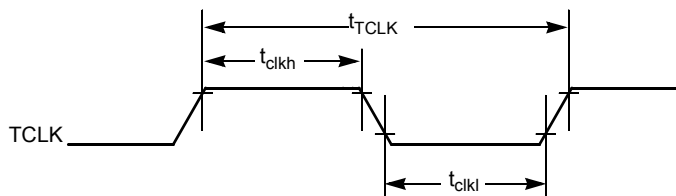


Figure 12. Timer External Clock

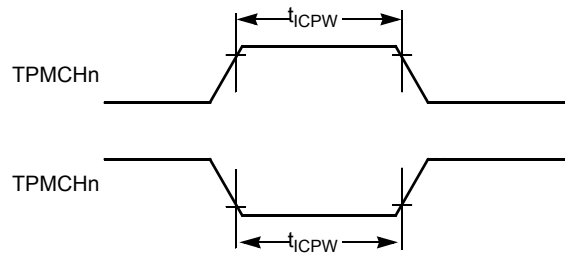


Figure 13. Timer Input Capture Pulse

### 3.9 Analog Comparator (ACMP) Electrical

Table 12. Analog Comparator Electrical Specifications

Characteristic	Symbol	Min	Typical	Max	Unit
Supply voltage	$V_{DD}$	2.7	—	5.5	V
Supply current (active)	$I_{DDAC}$	—	20	35	$\mu A$
Analog input voltage	$V_{AIN}$	$V_{SS} - 0.3$	—	$V_{DD}$	V
Analog input offset voltage <sup>1</sup>	$V_{AIO}$	—	20	40	mV
Analog Comparator hysteresis <sup>1</sup>	$V_H$	3.0	9.0	15.0	mV
Analog source impedance	$R_{AS}$	—	—	10	$k\Omega$
Analog input leakage current	$I_{ALKG}$	—	—	1.0	$\mu A$
Analog Comparator initialization delay	$t_{AINIT}$	—	—	1.0	$\mu s$
Analog Comparator bandgap reference voltage	$V_{BG}$	1.208	1.208	1.208	V

<sup>1</sup> These data are characterized but not production tested. Measurements are made with the device entered STOP mode.

### 3.10 Internal Clock Source Characteristics

Table 13. Internal Clock Source Specifications

Characteristic	Symbol	Min	Typical <sup>1</sup>	Max	Unit
Average internal reference frequency — untrimmed	$f_{int\_ut}$	25	31.25	41.66	kHz
Average internal reference frequency — trimmed	$f_{int\_t}$	31.25	39.0625 <sup>2</sup>	39.0625	kHz
DCO output frequency range — untrimmed	$f_{dco\_ut}$	12.8	16	21.33	MHz
DCO output frequency range — trimmed	$f_{dco\_t}$	16	20 <sup>3</sup>	20	MHz
Resolution of trimmed DCO output frequency at fixed voltage and temperature	$\Delta f_{dco\_res\_t}$	—	—	0.2	% $f_{dco}$
Total deviation of trimmed DCO output frequency over voltage and temperature	$\Delta f_{dco\_t}$	—	—	2	% $f_{dco}$
FLL acquisition time <sup>4,5</sup>	$t_{acquire}$	—	—	1	ms
Stop recovery time (FLL wakeup to previous acquired frequency) IREFSTEN = 0 IREFSTEN = 1	$t_{wakeup}$	—	100 86	—	$\mu s$

<sup>1</sup> Data in typical column was characterized at 3.0 V and 5.0 V, 25 °C or is typical recommended value.

<sup>2</sup> This value has been trimmed to 39.0625 kHz when out of factory

<sup>3</sup> This value has been trimmed to 20 MHz when out of factory

## Electrical Characteristics

- <sup>4</sup> This parameter is characterized and not tested on each device.
- <sup>5</sup> This specification applies to any time the FLL reference source or reference divider is changed, trim value changed or changing from FLL disabled (FBILP) to FLL enabled (FEI, FBI).

### 3.11 ADC Characteristics

**Table 14. 5 Volt 10-bit ADC Operating Conditions**

Characteristic	Conditions	Symbol	Min	Typical <sup>1</sup>	Max	Unit
Supply voltage	Absolute	$V_{DDAD}$	2.7	—	5.5	V
	Delta to $V_{DD}$ ( $V_{DD} - V_{DDAD}$ ) <sup>2</sup>	$\Delta V_{DDAD}$	-100	0	100	mV
Ground voltage	Delta to $V_{SS}$ ( $V_{SS} - V_{SSAD}$ ) <sup>2</sup>	$\Delta V_{SSAD}$	-100	0	100	mV
Ref voltage high	—	$V_{REFH}$	2.7	$V_{DDAD}$	$V_{DDAD}$	V
Ref voltage low	—	$V_{REFL}$	$V_{SSAD}$	$V_{SSAD}$	$V_{SSAD}$	V
Input voltage	—	$V_{ADIN}$	$V_{REFL}$	—	$V_{REFH}$	V
Input capacitance	—	$C_{ADIN}$	—	4.5	5.5	pF
Input resistance	—	$R_{ADIN}$	—	3	5	k $\Omega$
Analog source resistance external to MCU	10-bit mode $f_{ADCK} > 4\text{MHz}$ $f_{ADCK} < 4\text{MHz}$	$R_{AS}$	—	—	5	k $\Omega$
	8-bit mode (all valid $f_{ADCK}$ )		—	—	10	
ADC conversion clock frequency	High speed (ADLPC = 0)	$f_{ADCK}$	0.4	—	8.0	MHz
	Low power (ADLPC = 1)		0.4	—	4.0	

<sup>1</sup> Typical values assume  $V_{DDAD} = 5.0\text{ V}$ , Temp = 25 °C,  $f_{ADCK} = 1.0\text{ MHz}$  unless otherwise stated. Typical values are for reference only and are not tested in production.

<sup>2</sup> DC potential difference.

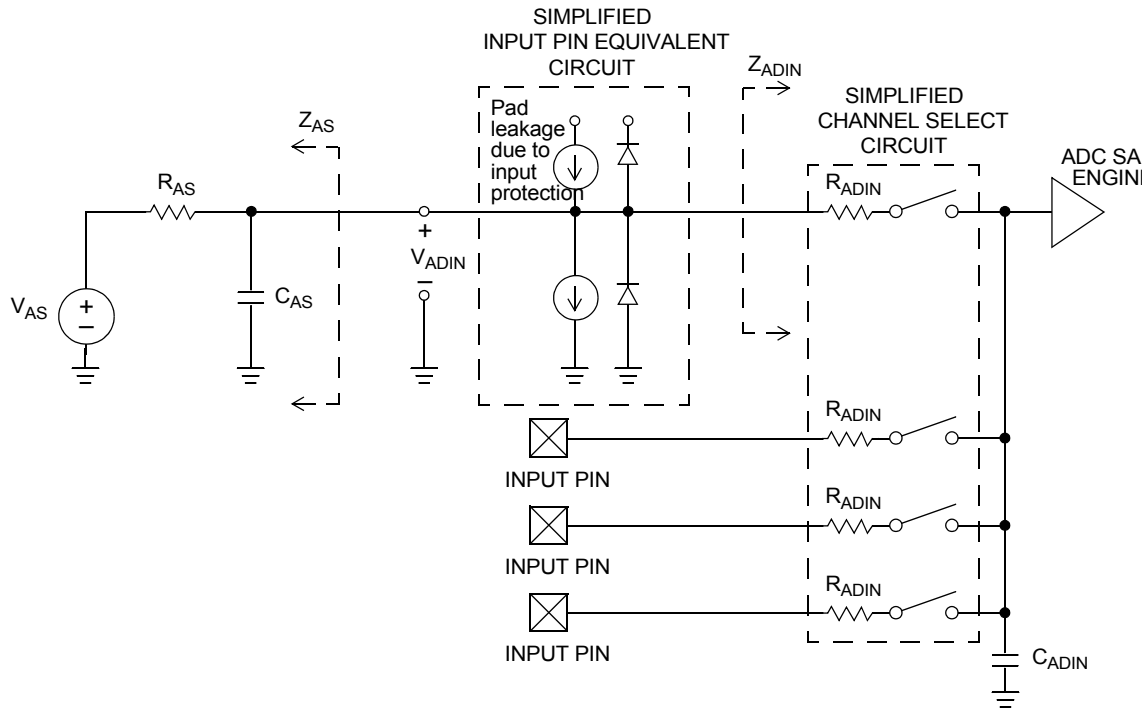


Figure 14. ADC Input Impedance Equivalency Diagram

 Table 15. 10-bit ADC Characteristics ( $V_{REFH} = V_{DDAD}$ ,  $V_{REFL} = V_{SSAD}$ )

Characteristic	Conditions	C	Symbol	Min	Typical <sup>1</sup>	Max	Unit
Supply current ADLPC=1 ADLSMP=1 ADCO=1		T	$I_{DDAD}$	—	133	—	$\mu\text{A}$
Supply current ADLPC=1 ADLSMP=0 ADCO=1		T	$I_{DDAD}$	—	218	—	$\mu\text{A}$
Supply current ADLPC=0 ADLSMP=1 ADCO=1		T	$I_{DDAD}$	—	327	—	$\mu\text{A}$
Supply current ADLPC=0 ADLSMP=0 ADCO=1	$V_{DDAD} \leq 5.5 \text{ V}$	P	$I_{DDAD}$	—	0.582	1	mA
Supply current	Stop, Reset, Module Off		$I_{DDAD}$	—	0.011	1	$\mu\text{A}$
ADC asynchronous clock source	High Speed (ADLPC = 0)	P	$f_{ADACK}$	2	3.3	5	MHz
	Low Power (ADLPC = 1)			1.25	2	3.3	

**Table 15. 10-bit ADC Characteristics ( $V_{REFH} = V_{DDAD}$ ,  $V_{REFL} = V_{SSAD}$ ) (continued)**

Characteristic	Conditions	C	Symbol	Min	Typical <sup>1</sup>	Max	Unit
Conversion time (Including sample time)	Short Sample (ADLSMP = 0)	P	$t_{ADC}$	—	20	—	ADCK cycles
	Long Sample (ADLSMP = 1)			—	40	—	
Sample time	Short Sample (ADLSMP = 0)	P	$t_{ADS}$	—	3.5	—	ADCK cycles
	Long Sample (ADLSMP = 1)			—	23.5	—	
Total unadjusted error	10-bit mode	P	$E_{TUE}$	—	$\pm 1$	$\pm 2.5$	LSB <sup>2</sup>
	8-bit mode			—	$\pm 0.5$	$\pm 1.0$	
Differential non-linearity	10-bit mode	P	DNL	—	$\pm 0.5$	$\pm 1.0$	LSB <sup>2</sup>
	8-bit mode			—	$\pm 0.3$	$\pm 0.5$	
	Monotonicity and no-missing-code guaranteed						
Integral non-linearity	10-bit mode	C	INL	—	$\pm 0.5$	$\pm 1.0$	LSB <sup>2</sup>
	8-bit mode			—	$\pm 0.3$	$\pm 0.5$	
Zero-scale error	10-bit mode	P	$E_{ZS}$	—	$\pm 0.5$	$\pm 1.5$	LSB <sup>2</sup>
	8-bit mode			—	$\pm 0.5$	$\pm 0.5$	
Full-scale error $V_{ADIN} = V_{DDA}$	10-bit mode	P	$E_{FS}$	—	$\pm 0.5$	$\pm 1.5$	LSB <sup>2</sup>
	8-bit mode			—	$\pm 0.5$	$\pm 0.5$	
Quantization error	10-bit mode	D	$E_Q$	—	—	$\pm 0.5$	LSB <sup>2</sup>
	8-bit mode			—	—	$\pm 0.5$	
Input leakage error pad leakage <sup>3</sup> * RAS	10-bit mode	D	$E_{IL}$	—	$\pm 0.2$	$\pm 2.5$	LSB <sup>2</sup>
	8-bit mode			—	$\pm 0.1$	$\pm 1$	

<sup>1</sup> Typical values assume  $V_{DDAD} = 5.0$  V, Temp = 25 °C,  $f_{ADCK} = 1.0$  MHz unless otherwise stated. Typical values are for reference only and are not tested in production.

<sup>2</sup> 1 LSB =  $(V_{REFH} - V_{REFL})/2^N$

<sup>3</sup> Based on input pad leakage current. Refer to pad electrical.

## 3.12 AC Characteristics

This section describes AC timing characteristics for each peripheral system.

### 3.12.1 Control Timing

**Table 16. Control Timing**

Characteristic	Symbol	Min	Typical	Max	Unit
Bus frequency ( $t_{cyc} = 1/f_{Bus}$ )	$f_{Bus}$	DC	—	10	MHz
Real time interrupt internal oscillator period	$t_{RTI}$	700	1000	1300	$\mu$ s

Table 16. Control Timing (continued)

Characteristic	Symbol	Min	Typical	Max	Unit
External $\overline{\text{RESET}}$ pulse width <sup>1</sup>	$t_{\text{extrst}}$	150		—	ns
KBI pulse width <sup>2</sup>	$t_{\text{KBIPW}}$	$1.5 t_{\text{cyc}}$		—	ns
KBI pulse width in stop <sup>1</sup>	$t_{\text{KBIPWS}}$	100		—	ns
Port rise and fall time (load = 50 pF) <sup>3</sup> Slew rate control disabled (PTxSE = 0) Slew rate control enabled (PTxSE = 1)	$t_{\text{Rise}}, t_{\text{Fall}}$	— —	11 35	— —	ns

<sup>1</sup> This is the shortest pulse that is guaranteed to pass through the pin input filter circuitry. Shorter pulses may or may not be recognized.

<sup>2</sup> This is the minimum pulse width that is guaranteed to pass through the pin synchronization circuitry. Shorter pulses may or may not be recognized. In stop mode, the synchronizer is bypassed so shorter pulses can be recognized in that case.

<sup>3</sup> Timing is shown with respect to 20%  $V_{\text{DD}}$  and 80%  $V_{\text{DD}}$  levels. Temperature range  $-40^{\circ}\text{C}$  to  $85^{\circ}\text{C}$ .

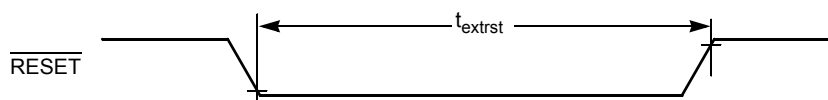


Figure 15. Reset Timing

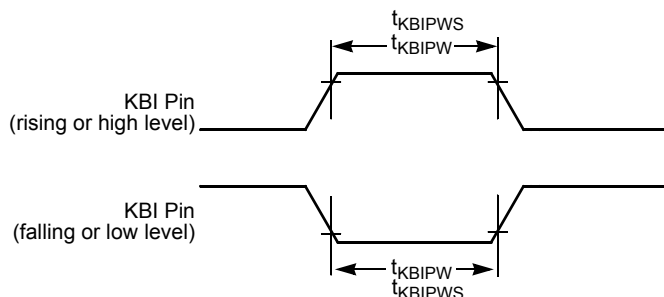


Figure 16. KBI Pulse Width

### 3.13 Flash Specifications

This section provides details about program/erase times and program-erase endurance for the flash memory. For detailed information about program/erase operations, see the reference manual.

Table 17. Flash Characteristics

Characteristic	Symbol	Min	Typical <sup>1</sup>	Max	Unit
Supply voltage for program/erase	$V_{\text{DD}}$	2.7	—	5.5	V
Program/Erase voltage	$V_{\text{PP}}$	11.8	12	12.2	V
$V_{\text{PP}}$ current					
Program	$I_{\text{VPP\_prog}}$	—	—	200	$\mu\text{A}$
Mass erase	$I_{\text{VPP\_erase}}$	—	—	100	$\mu\text{A}$
Supply voltage for read operation $0 < f_{\text{Bus}} < 10 \text{ MHz}$	$V_{\text{Read}}$	2.7	—	5.5	V

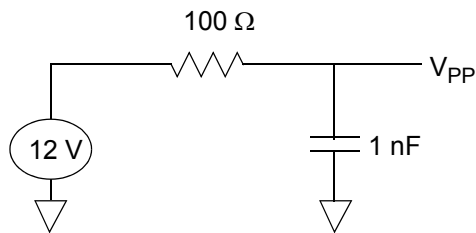
**Table 17. Flash Characteristics (continued)**

Characteristic	Symbol	Min	Typical <sup>1</sup>	Max	Unit
Byte program time	$t_{prog}$	20	—	40	$\mu$ s
Mass erase time	$t_{me}$	500	—	—	ms
Cumulative program HV time <sup>2</sup>	$t_{hv}$	—	—	8	ms
Total cumulative HV time (total of $t_{me}$ & $t_{hv}$ applied to device)	$t_{hv\_total}$	—	—	2	hours
HVEN to program setup time	$t_{pgs}$	10	—	—	$\mu$ s
PGM/MASS to HVEN setup time	$t_{nvs}$	5	—	—	$\mu$ s
HVEN hold time for PGM	$t_{nh}$	5	—	—	$\mu$ s
HVEN hold time for MASS	$t_{nh1}$	100	—	—	$\mu$ s
$V_{PP}$ to PGM/MASS setup time	$t_{vps}$	20	—	—	ns
HVEN to $V_{PP}$ hold time	$t_{vph}$	20	—	—	ns
$V_{PP}$ rise time <sup>3</sup>	$t_{vrs}$	200	—	—	ns
Recovery time	$t_{rcv}$	1	—	—	$\mu$ s
Program/erase endurance $T_L$ to $T_H = -40\text{ }^\circ\text{C}$ to $85\text{ }^\circ\text{C}$	—	1000	—	—	cycles
Data retention	$t_{D\_ret}$	15	—	—	years

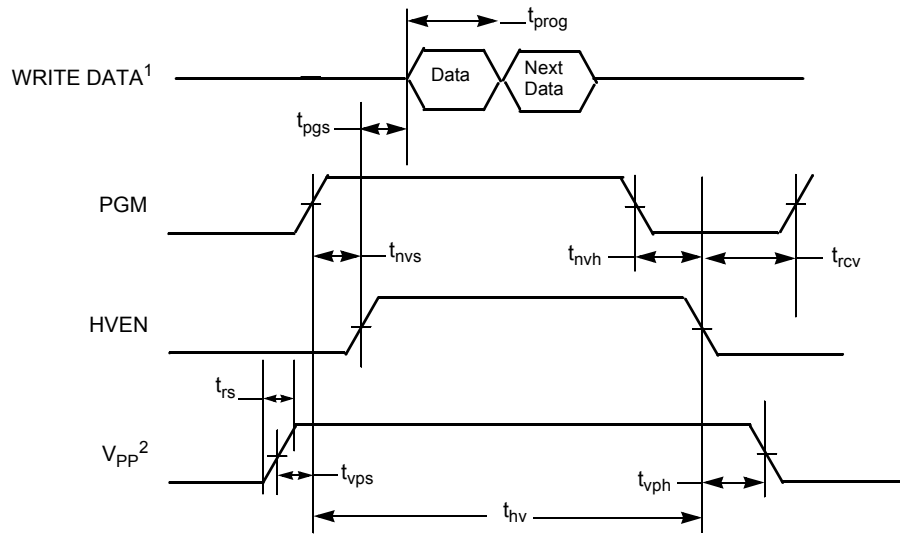
<sup>1</sup> Typicals are measured at 25 °C.

<sup>2</sup>  $t_{hv}$  is the cumulative high voltage programming time to the same row before next erase. Same address can not be programmed more than twice before next erase.

<sup>3</sup> Fast  $V_{PP}$  rise time may potentially trigger the ESD protection structure, which may result in over current flowing into the pad and cause permanent damage to the pad. External filtering for the  $V_{PP}$  power source is recommended. An example  $V_{PP}$  filter is shown in [Figure 17](#).

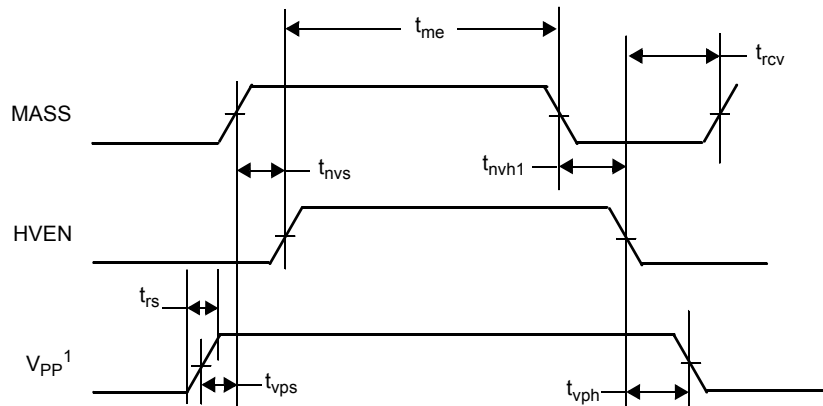


**Figure 17. Example  $V_{PP}$  Filtering**



- <sup>1</sup> Next Data applies if programming multiple bytes in a single row, refer to *MC9RS08LA8 Series Reference Manual*.
- <sup>2</sup>  $V_{DD}$  must be at a valid operating voltage before voltage is applied or removed from the  $V_{PP}$  pin.

**Figure 18. Flash Program Timing**

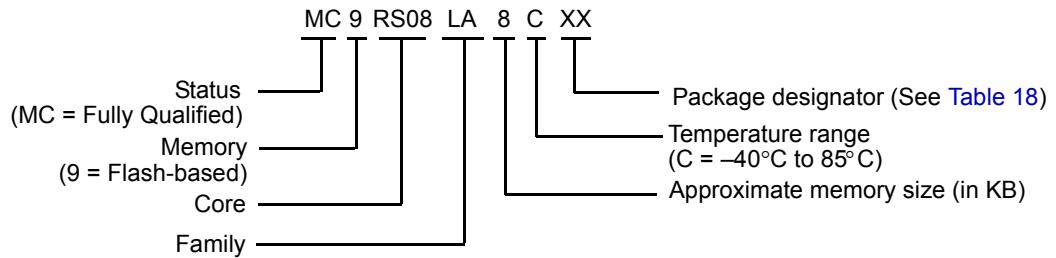


- <sup>1</sup>  $V_{DD}$  must be at a valid operating voltage before voltage is applied or removed from the  $V_{PP}$  pin.

**Figure 19. Flash Mass Erase Timing**

## 4 Ordering Information

This section contains ordering information for MC9RS08LA8 devices. See below for an example of the device numbering system.



## 5 Package Information and Mechanical Drawings

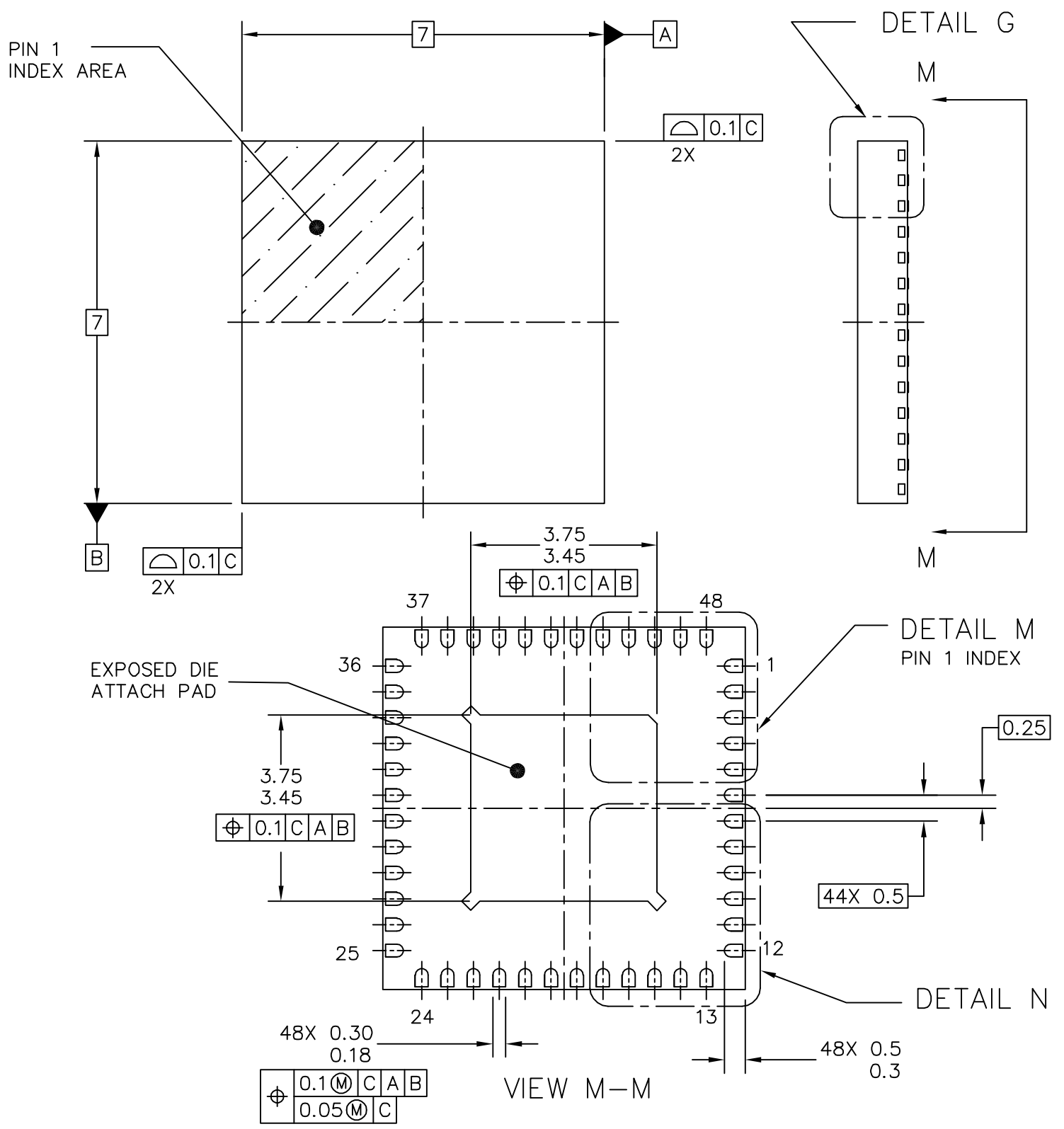
Table 18 provides the available package types and their document numbers. The latest package outline/mechanical drawings are available on the MC9RS08LA8 Series Product Summary pages at <http://www.freescale.com>.

To view the latest drawing, either:

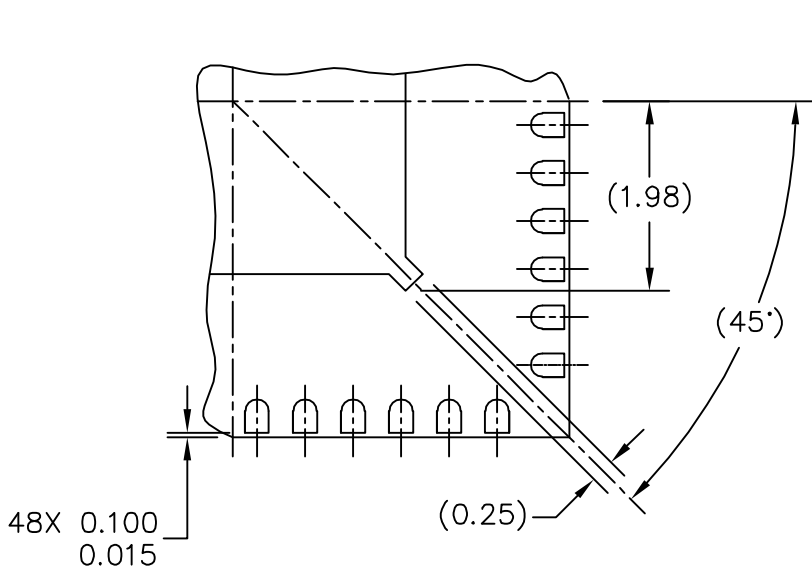
- Click on the appropriate link in Table 18, or
- Open a browser to the Freescale® website (<http://www.freescale.com>), and enter the appropriate document number (from Table 18) in the “Enter Keyword” search box at the top of the page.

**Table 18. Device Numbering System**

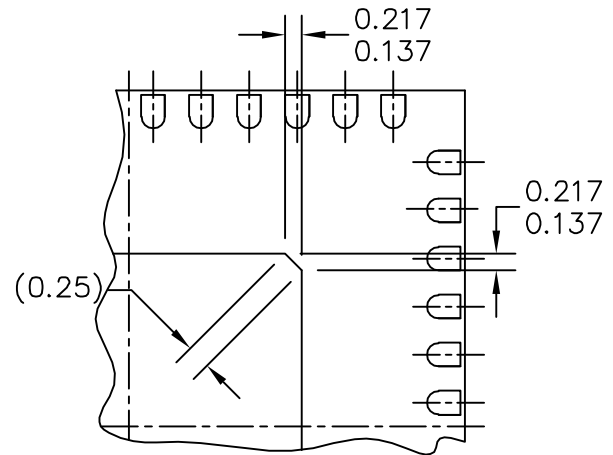
Device Number	Memory		Package		
	FLASH	RAM	Type	Designator	Document No.
<b>MC9RS08LA8</b>	8 KB	256 bytes	48-Pin QFN	FT	<a href="#">98ARL10606D</a>
			48-Pin LQFP	LF	<a href="#">98ASH00962A</a>



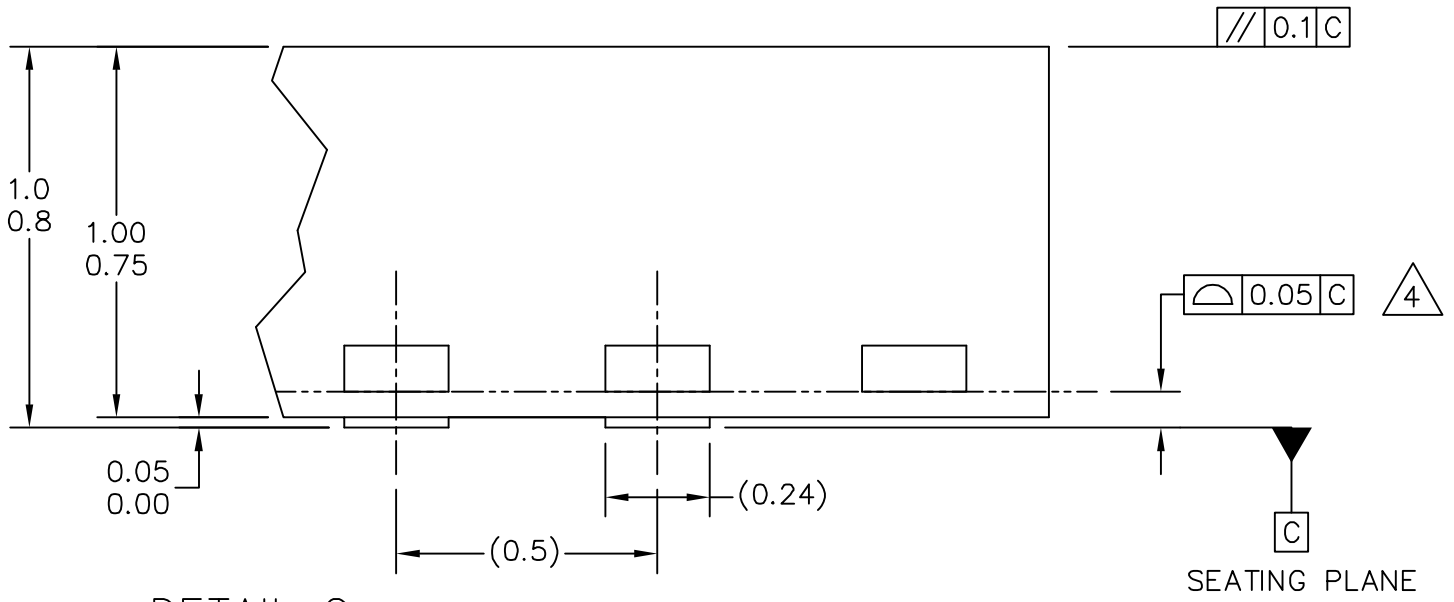
© FREESCALE SEMICONDUCTOR, INC. ALL RIGHTS RESERVED.	<b>MECHANICAL OUTLINE</b>	PRINT VERSION NOT TO SCALE	
TITLE: THERMALLY ENHANCED QUAD FLAT NON-LEADED PACKAGE (QFN) 48 TERMINAL, 0.5 PITCH (7 X 7 X 1)	DOCUMENT NO: 98ARL10606D	REV: 0	
	CASE NUMBER: 1975-01	29 AUG 2007	
	STANDARD: JEDEC-MO-220 VKKD-2		



DETAIL N  
PREFERRED CORNER CONFIGURATION



DETAIL M  
PREFERRED PIN 1 BACKSIDE IDENTIFIER




DETAIL G  
VIEW ROTATED 90° CW

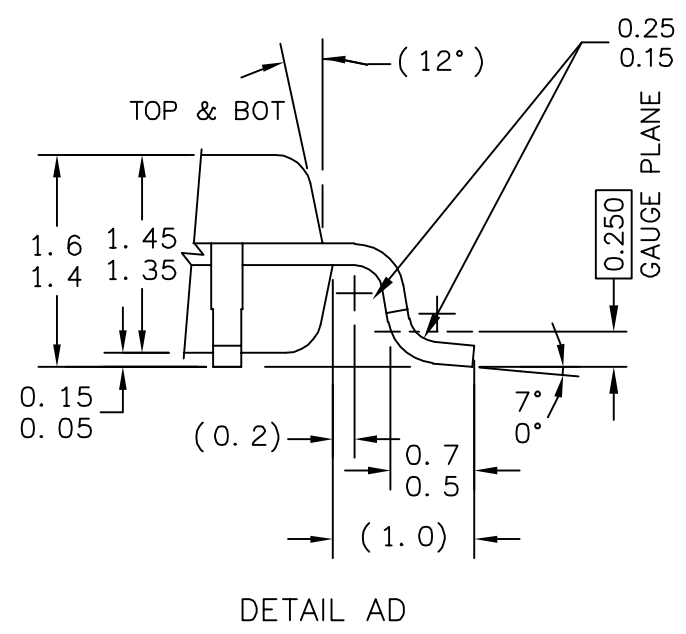
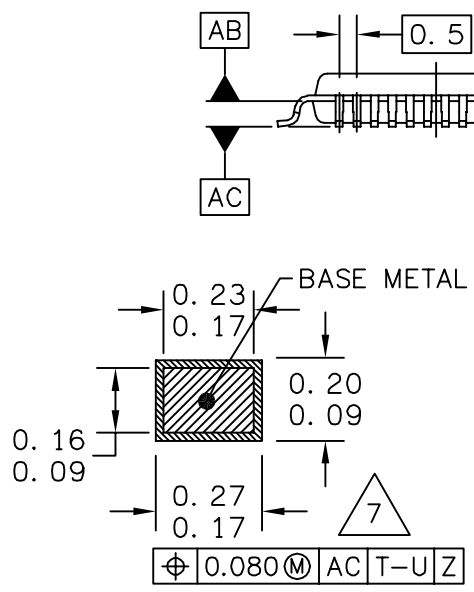
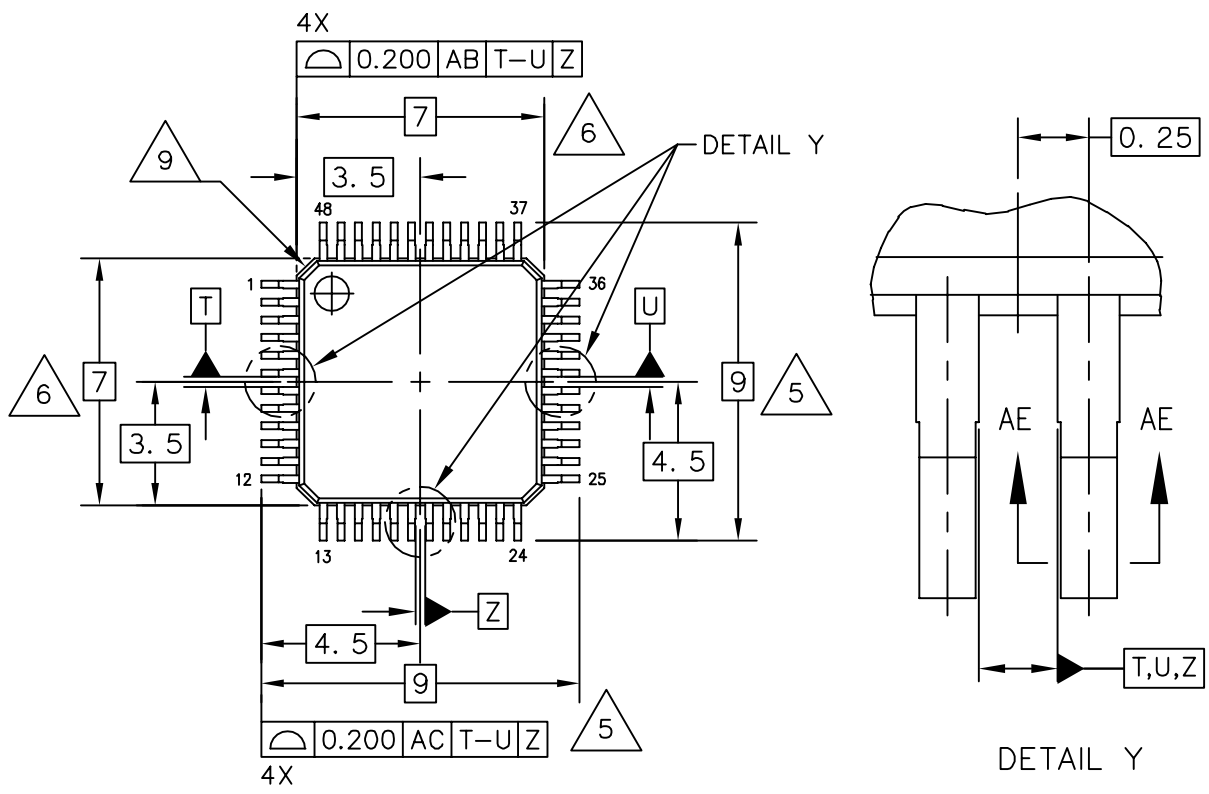
© FREESCALE SEMICONDUCTOR, INC. ALL RIGHTS RESERVED.	<b>MECHANICAL OUTLINE</b>	PRINT VERSION NOT TO SCALE	
TITLE: THERMALLY ENHANCED QUAD FLAT NON-LEADED PACKAGE (QFN) 48 TERMINAL, 0.5 PITCH (7 X 7 X 1)	DOCUMENT NO: 98ARL10606D	REV: 0	
	CASE NUMBER: 1975-01	29 AUG 2007	
	STANDARD: JEDEC-MO-220 VKKD-2		



NOTES:

1. DIMENSIONS ARE IN MILLIMETERS.
2. INTERPRET DIMENSIONS AND TOLERANCES PER ASME Y14.5M-1994.
3. THE COMPLETE JEDEC DESIGNATOR FOR THIS PACKAGE IS: HF-PQFN.
4.  COPLANARITY APPLIES TO LEADS, CORNER LEADS, AND DIE ATTACH PAD.
5. MIN METAL GAP SHOULD BE 0.2MM.

© FREESCALE SEMICONDUCTOR, INC. ALL RIGHTS RESERVED.	<b>MECHANICAL OUTLINE</b>	PRINT VERSION NOT TO SCALE	
TITLE: THERMALLY ENHANCED QUAD FLAT NON-LEADED PACKAGE (QFN) 48 TERMINAL, 0.5 PITCH (7 X 7 X 1)	DOCUMENT NO: 98ARL10606D	REV: 0	
	CASE NUMBER: 1975-01	29 AUG 2007	
	STANDARD: JEDEC-MO-220 VKKD-2		



SECTION AE-AE

DETAIL AD

© FREESCALE SEMICONDUCTOR, INC. ALL RIGHTS RESERVED.	<b>MECHANICAL OUTLINE</b>	PRINT VERSION NOT TO SCALE	
TITLE: LQFP, 48 LEAD, 0.50 PITCH (7.0 X 7.0 X 1.4)	DOCUMENT NO: 98ASH00962A	REV: G	
	CASE NUMBER: 932-03	14 APR 2005	
	STANDARD: JEDEC MS-026-BBC		



NOTES:

1. DIMENSIONS AND TOLERANCING PER ASME Y14.5M-1994.
2. CONTROLLING DIMENSION: MILLIMETER.
3. DATUM PLANE AB IS LOCATED AT BOTTOM OF LEAD AND IS COINCIDENT WITH THE LEAD WHERE THE LEAD EXITS THE PLASTIC BODY AT THE BOTTOM OF THE PARTING LINE.
4. DATUMS T, U, AND Z TO BE DETERMINED AT DATUM PLANE AB.

5. DIMENSIONS TO BE DETERMINED AT SEATING PLANE AC.

6. DIMENSIONS DO NOT INCLUDE MOLD PROTRUSION. ALLOWABLE PROTRUSION IS 0.250 PER SIDE. DIMENSIONS DO INCLUDE MOLD MISMATCH AND ARE DETERMINED AT DATUM PLANE AB.

7. THIS DIMENSION DOES NOT INCLUDE DAMBAR PROTRUSION. DAMBAR PROTRUSION SHALL NOT CAUSE THE LEAD WIDTH TO EXCEED 0.350.

8. MINIMUM SOLDER PLATE THICKNESS SHALL BE 0.0076.

9. EXACT SHAPE OF EACH CORNER IS OPTIONAL.

© FREESCALE SEMICONDUCTOR, INC. ALL RIGHTS RESERVED.	<b>MECHANICAL OUTLINE</b>	PRINT VERSION NOT TO SCALE	
TITLE: LQFP, 48 LEAD, 0.50 PITCH (7.0 X 7.0 X 1.4)	DOCUMENT NO: 98ASH00962A	REV: G	
	CASE NUMBER: 932-03	14 APR 2005	
	STANDARD: JEDEC MS-026-BBC		



## How to Reach Us:

### Home Page:

[www.freescale.com](http://www.freescale.com)

### Web Support:

<http://www.freescale.com/support>

### USA/Europe or Locations Not Listed:

Freescale Semiconductor, Inc.  
Technical Information Center, EL516  
2100 East Elliot Road  
Tempe, Arizona 85284  
1-800-521-6274 or +1-480-768-2130  
[www.freescale.com/support](http://www.freescale.com/support)

### Europe, Middle East, and Africa:

Freescale Halbleiter Deutschland GmbH  
Technical Information Center  
Schatzbogen 7  
81829 Muenchen, Germany  
+44 1296 380 456 (English)  
+46 8 52200080 (English)  
+49 89 92103 559 (German)  
+33 1 69 35 48 48 (French)  
[www.freescale.com/support](http://www.freescale.com/support)

### Japan:

Freescale Semiconductor Japan Ltd.  
Headquarters  
ARCO Tower 15F  
1-8-1, Shimo-Meguro, Meguro-ku,  
Tokyo 153-0064  
Japan  
0120 191014 or +81 3 5437 9125  
[support.japan@freescale.com](mailto:support.japan@freescale.com)

### Asia/Pacific:

Freescale Semiconductor China Ltd.  
Exchange Building 23F  
No. 118 Jianguo Road  
Chaoyang District  
Beijing 100022  
China  
+86 10 5879 8000  
[support.asia@freescale.com](mailto:support.asia@freescale.com)

### For Literature Requests Only:

Freescale Semiconductor Literature Distribution Center  
P.O. Box 5405  
Denver, Colorado 80217  
1-800-441-2447 or +1-303-675-2140  
Fax: +1-303-675-2150  
[LDCForFreescaleSemiconductor@hibbertgroup.com](mailto:LDCForFreescaleSemiconductor@hibbertgroup.com)

Information in this document is provided solely to enable system and software implementers to use Freescale Semiconductor products. There are no express or implied copyright licenses granted hereunder to design or fabricate any integrated circuits or integrated circuits based on the information in this document.

Freescale Semiconductor reserves the right to make changes without further notice to any products herein. Freescale Semiconductor makes no warranty, representation or guarantee regarding the suitability of its products for any particular purpose, nor does Freescale Semiconductor assume any liability arising out of the application or use of any product or circuit, and specifically disclaims any and all liability, including without limitation consequential or incidental damages. "Typical" parameters that may be provided in Freescale Semiconductor data sheets and/or specifications can and do vary in different applications and actual performance may vary over time. All operating parameters, including "Typicals", must be validated for each customer application by customer's technical experts. Freescale Semiconductor does not convey any license under its patent rights nor the rights of others. Freescale Semiconductor products are not designed, intended, or authorized for use as components in systems intended for surgical implant into the body, or other applications intended to support or sustain life, or for any other application in which the failure of the Freescale Semiconductor product could create a situation where personal injury or death may occur. Should Buyer purchase or use Freescale Semiconductor products for any such unintended or unauthorized application, Buyer shall indemnify and hold Freescale Semiconductor and its officers, employees, subsidiaries, affiliates, and distributors harmless against all claims, costs, damages, and expenses, and reasonable attorney fees arising out of, directly or indirectly, any claim of personal injury or death associated with such unintended or unauthorized use, even if such claim alleges that Freescale Semiconductor was negligent regarding the design or manufacture of the part.

RoHS-compliant and/or Pb-free versions of Freescale products have the functionality and electrical characteristics as their non-RoHS-compliant and/or non-Pb-free counterparts. For further information, see <http://www.freescale.com> or contact your Freescale sales representative.

For information on Freescale's Environmental Products program, go to <http://www.freescale.com/epp>.

Freescale™ and the Freescale logo are trademarks of Freescale Semiconductor, Inc. All other product or service names are the property of their respective owners.

© Freescale Semiconductor, Inc. 2008-2012. All rights reserved.



Document Number: MC9RS08LA8

Rev. 2

1/2012

## Looking for pricing, stock, or lifecycle information?

Click below to explore more details on WIN SOURCE:

-  [View PC9RS08LA8CFT on WIN SOURCE](#)
-  [Freescale Semiconductor - NXP Information](#)

## Optimize Your Supply Chain with WIN SOURCE Solutions

-  Global Sourcing Solution
-  Obsolete Management
-  Cost Control Management
-  Shortage Management
-  Alternative Solution
-  Excess Inventory Management