

PC929 Series

High Speed, Built-in Short
Protection Circuit, Gate Drive
SMD 14 pin *OPIC Photocoupler

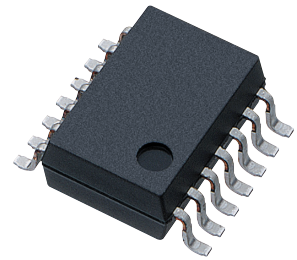

■ Description

PC929 Series contains an IRED optically coupled to an OPIC chip.

It is packaged in a Mini-flat, Half pitch type (14 pin).

Input-output isolation voltage(rms) is 4.0kV. High speed response (t_{PLH} , t_{PHL} : MAX. 0.5 μ s).

■ Features

1. 14 pin Half pitch type (Lead pitch : 1.27 mm)
2. Double transfer mold package
(Ideal for Flow Soldering)
3. Built-in IGBT shortcircuit protector circuit
4. Built-in direct drive circuit for IGBT drive
(Peak output current : I_{O1P} , I_{O2P} : MAX. 0.4 A)
5. High speed response (t_{PLH} , t_{PHL} : MAX. 0.5 μ s)
6. High isolation voltage ($V_{iso(rms)}$: 4.0 kV)

■ Agency approvals/Compliance

1. Recognized by UL1577 (Double protection isolation), file No. E64380 (as model No. **PC929**)
2. Approved by VDE (VDE0884) (as an option) file No. 94626 (as model No. **PC929**)
3. Package resin : UL flammability grade (94V-0)

■ Applications

1. Inverter

* "OPIC"(Optical IC) is a trademark of the SHARP Corporation. An OPIC consists of a light-detecting element and a signal-processing circuit integrated onto a single chip.

Notice The content of data sheet is subject to change without prior notice.

In the absence of confirmation by device specification sheets, SHARP takes no responsibility for any defects that may occur in equipment using any SHARP devices shown in catalogs, data books, etc. Contact SHARP in order to obtain the latest device specification sheets before using any SHARP device.

Internal Connection Diagram

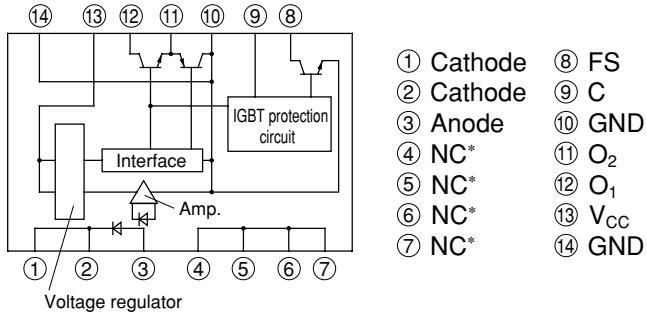

Truth table

Input	C input-output	O ₂ output	FS output	
ON	Low level	High level	High level	
	High level	Low level	Low level	At operating protection function
OFF	Low level	Low level	High level	
	High level	Low level	High level	

Outline Dimensions

(Unit : mm)

1. SMT Gullwing Lead-Form [ex. PC929P]

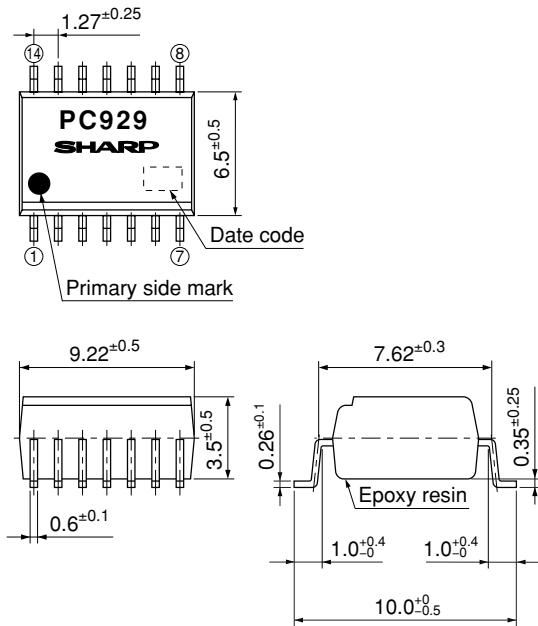

2. SMT Gullwing Lead-Form (VDE0884 option) [ex. PC929PY]

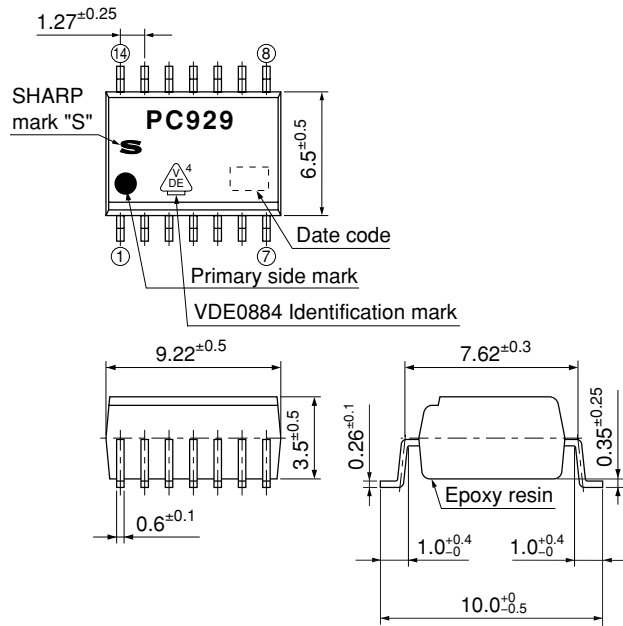

Product mass : approx. 0.47g

Date code (2 digit)

1st digit				2nd digit	
Year of production				Month of production	
A.D.	Mark	A.D	Mark	Month	Mark
1990	A	2002	P	January	1
1991	B	2003	R	February	2
1992	C	2004	S	March	3
1993	D	2005	T	April	4
1994	E	2006	U	May	5
1995	F	2007	V	June	6
1996	H	2008	W	July	7
1997	J	2009	X	August	8
1998	K	2010	A	September	9
1999	L	2011	B	October	O
2000	M	2012	C	November	N
2001	N	∴	∴	December	D

repeats in a 20 year cycle

Country of origin

Japan

■ Absolute Maximum Ratings

(unless otherwise specified $T_a=T_{opr}$)

	Parameter	Symbol	Rating	Unit
Input	*1 Forward current	I_F	20	mA
	*2 Reverse voltage	V_R	6	V
Output	Supply voltage	V_{CC}	35	V
	O ₁ output current	I_{O1}	0.1	A
	*3 O ₁ peak output current	I_{O1P}	0.4	A
	O ₂ output current	I_{O2}	0.1	A
	*3 O ₂ peak output current	I_{O2P}	0.4	A
	O ₁ output voltage	V_{O1}	35	V
	*4 Power dissipation	P_O	500	mW
	Overcurrent detection voltage	V_C	V_{CC}	V
	Overcurrent detection current	I_C	30	mA
	Error signal output voltage	V_{FS}	V_{CC}	V
	Error signal output current	I_{FS}	20	mA
*5 Total power dissipation	P_{tot}	550	mW	
*6 Isolation voltage	$V_{iso (rms)}$	4.0	kV	
Operating temperature	T_{opr}	-25 to +80	°C	
Storage temperature	T_{stg}	-55 to +125	°C	
*7 Soldering temperature	T_{sol}	260	°C	

*1 The derating factors of a absolute maximum ratings due to ambient temperature are shown in Fig.15

*2 $T_a=25^\circ\text{C}$

*3 Pulse width $\leq 0.15\mu\text{s}$, Duty ratio : 0.01

*4.5 The derating factors of a absolute maximum ratings due to ambient temperature are shown in Fig.16

*6 AC for 1minute, 40 to 60 %RH, $T_a=25^\circ\text{C}$, $f=60\text{Hz}$

*7 For 10s

■ Electro-optical Characteristics

(unless otherwise specified $T_a=T_{opr}$)

	Parameter	Symbol	Conditions *8	MIN.	TYP.	MAX.	Unit
Input	Forward voltage	V_{F1}	$T_a=25^\circ\text{C}$, $I_F=10\text{mA}$	-	1.6	1.75	V
		V_{F2}	$T_a=25^\circ\text{C}$, $I_F=0.2\text{mA}$	1.2	1.5	-	V
	Reverse current	I_R	$T_a=25^\circ\text{C}$, $V_R=5\text{V}$	-	-	10	μA
	Terminal capacitance	C_t	$T_a=25^\circ\text{C}$, $V=0$, $f=1\text{kHz}$	-	30	250	pF
Output	Supply voltage	V_{CC}	$T_a=-10$ to $+60^\circ\text{C}$	15	-	30	V
			-	15	-	24	V
	O ₁ Low level output voltage	V_{O1L}	$V_{CC1}=12\text{V}$, $V_{CC2}=-12\text{V}$, $I_{O1}=0.1\text{A}$, $I_F=5\text{mA}^{*9}$	-	0.2	0.4	V
	O ₂ High level output voltage	V_{O2H}	$V_{CC}=V_{O1}=24\text{V}$, $I_{O2}=-0.1\text{A}$, $I_F=5\text{mA}^{*9}$	20	22	-	V
	O ₂ Low level output voltage	V_{O2L}	$V_{CC}=24\text{V}$, $I_{O2}=0.1\text{A}$, $I_F=0^{*9}$	-	1.2	2.0	V
	O ₁ leak current	I_{O1L}	$T_a=25^\circ\text{C}$, $V_{CC}=V_{O1}=35\text{V}$, $I_F=0^{*9}$	-	-	500	μA
	High level supply current	I_{CCH}	$T_a=25^\circ\text{C}$, $V_{CC}=V_{O1}=24\text{V}$, $I_F=5\text{mA}^{*9}$	-	10	17	mA
			$V_{CC}=V_{O1}=24\text{V}$, $I_F=5\text{mA}^{*9}$	-	-	19	mA
Low level supply current	I_{CCL}	$T_a=25^\circ\text{C}$, $V_{CC}=V_{O1}=24\text{V}$, $I_F=0^{*9}$	-	11	18	mA	
		$V_{CC}=V_{O1}=24\text{V}$, $I_F=0^{*9}$	-	-	20	mA	

*8 It shall connect a by-pass capacitor of 0.01 μF or more between V_{CC} (pin ③) and GND (pin, ⑩, ⑬) near the device, when it measures the transfer characteristics and the output side characteristics.

*9 FS=OPEN, $V_C=0$

(unless otherwise specified $T_a=T_{opr}$)

Parameter		Symbol	Conditions *10	MIN.	TYP.	MAX.	Unit	
Transfer characteristics	*11 "Low→High" input threshold current	I_{FLH}	$T_a=25^\circ\text{C}, V_{CC}=V_{O1}=24\text{V}, FS=OPEN, V_C=0$	0.3	1.5	3.0	mA	
			$V_{CC}=V_{O1}=24\text{V}, FS=OPEN, V_C=0$	0.2	-	5.0	mA	
	Isolation resistance	R_{ISO}	$T_a=25^\circ\text{C}, DC=500\text{V}, 40 \text{ to } 60\%RH$	5×10^{10}	10^{11}	-	Ω	
	Response time	"Low→High" propagation delay time	t_{PLH}	$T_a=25^\circ\text{C},$ $V_{CC}=V_{O1}=24\text{V}, I_F=5\text{mA},$ $R_G=47\Omega, C_G=3\ 000\text{pF}$ $FS=OPEN, V_C=0$	-	0.3	0.5	μs
		"High→Low" propagation delay time	t_{PHL}		-	0.3	0.5	μs
		Rise time	t_r		-	0.2	0.5	μs
		Fall time	t_f		-	0.2	0.5	μs
	Instantaneous common mode rejection voltage (High level output)	CM_H	$T_a=25^\circ\text{C}, V_{CM}=600\text{V(p-p)}$ $I_F=5\text{mA}, V_{CC}=V_{O1}=24\text{V},$ $\Delta V_{O2H}=2.0\text{V}, FS=OPEN, V_C=0$	-1.5	-	-	kV/ μs	
	Instantaneous common mode rejection voltage (Low level output)	CM_L	$T_a=25^\circ\text{C}, V_{CM}=600\text{V(p-p)}$ $I_F=0, V_{CC}=V_{O1}=24\text{V},$ $\Delta V_{O2L}=2.0\text{V}, FS=OPEN, V_C=0$	1.5	-	-	kV/ μs	
	Overcurrent detection	*12 Overcurrent detection voltage	V_{CTH}	$T_a=25^\circ\text{C}$ $V_{CC}=V_{O1}=24\text{V}$ $I_F=5\text{mA}, R_G=47\Omega$ $C_G=3\ 000\text{pF}, FS=OPEN$	$V_{CC}-6.5$	$V_{CC}-6$	$V_{CC}-5.5$	V
Overcurrent detection voltage hysteresis width		V_{CHIS}	1		2	3	V	
Protection output	O ₂ "High→Low" propagation delay time at overcurrent protection	t_{PCOHL}	$T_a=25^\circ\text{C}$ $V_{CC}=V_{O1}=24\text{V}$ $I_F=5\text{mA},$ $R_G=47\Omega, C_G=3\ 000\text{pF},$ $R_C=1\text{k}\Omega, C_P=3\ 000\text{pF}$ $FS=OPEN$	-	4	10	μs	
	O ₂ Fall time at overcurrent protection	t_{PCOf}		2	5	-	μs	
	O ₂ "High→Low" output voltage at overcurrent protection	V_{OE}		-	-	2	V	
Error signal output	Low level error signal voltage	V_{FSL}	$T_a=25^\circ\text{C}, I_F=5\text{mA}$ $V_{CC}=V_{O1}=24\text{V}$ $I_{FS}=10\text{mA}, R_G=47\Omega$ $C_G=3\ 000\text{pF}, C=OPEN$	-	0.2	0.4	V	
	High level error signal voltage	I_{FSH}		-	-	100	μA	
	Error signal "High→Low" propagation delay time	t_{PCFHL}		$T_a=25^\circ\text{C}, V_{CC}=V_{O1}=24\text{V}$ $I_F=5\text{mA}, R_{FS}=1.8\text{k}\Omega$ $R_G=47\Omega, R_C=1\text{k}\Omega$ $C_G=3\ 000\text{pF}, C_P=1\ 000\text{pF}$	-	1	5	μs
	Error signal output pulse width	Δt_{FS}			20	35	-	μs

*10 It shall connect a by-pass capacitor of 0.01 μF or more between V_{CC} (pin ⑬) and GND (pin ⑩, ⑭) near the device, when it measures the device, when it measures the overcurrent characteristics, Protection output characteristics, and Error signal output characteristics.

*11 I_{FLH} represents forward current when output goes from "Low" to "High"

*12 V_{CTH} is the of C(pin ⑨) voltage when output becomes from "High" to "Low"

■ Model Line-up

Lead Form	SMT Gullwing			
Package	Sleeve		Taping	
	50pcs/sleeve		1 000pcs/reel	
VDE0884	——	Approved	——	Approved
Model No.	PC929	PC929Y	PC929P	PC929PY

Please contact a local SHARP sales representative to inquire about production status and Lead-Free options.

Fig.1 Test Circuit for O₁ Low Level Output Voltage

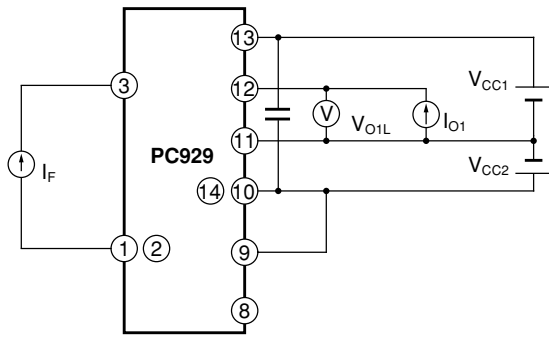

Fig.2 Test Circuit for O₂ High Level Output Voltage

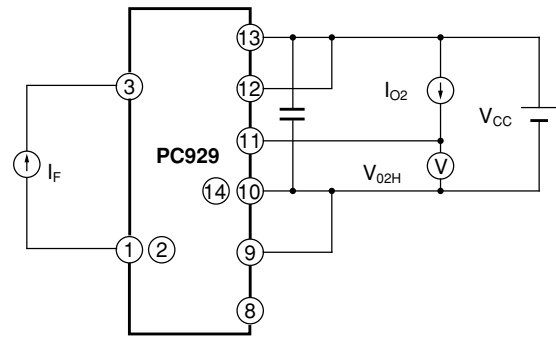

Fig.3 Test Circuit for O₂ Low Level Output Voltage

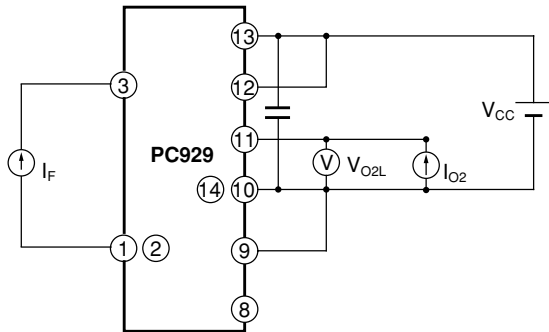

Fig.4 Test Circuit for O₁ Leak Current

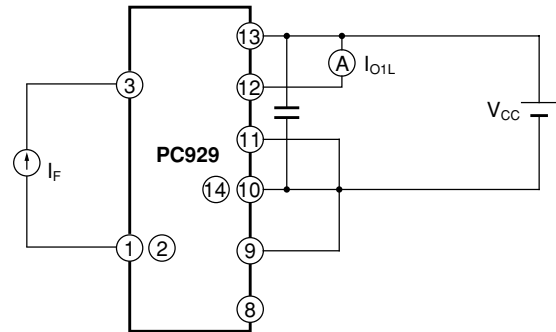

Fig.5 Test Circuit for "Low→High" Input Threshold Current

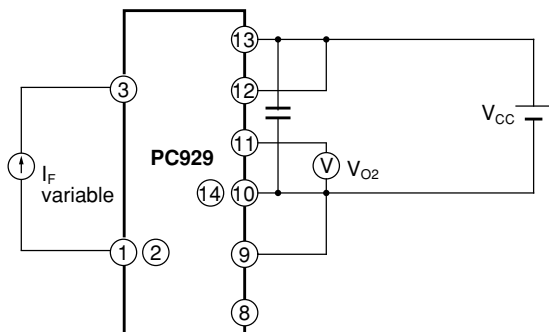

Fig.6 Test Circuit for High Level / Low Level Supply Current

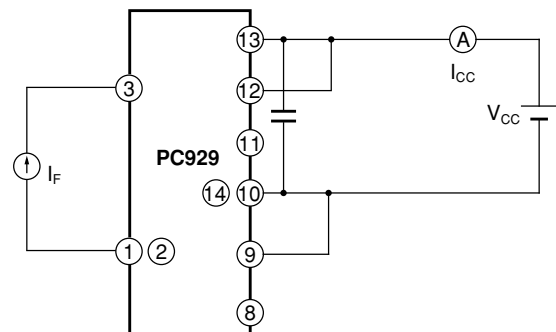

Fig.7 Test Circuit for Instantaneous Common Mode Rejection Voltage

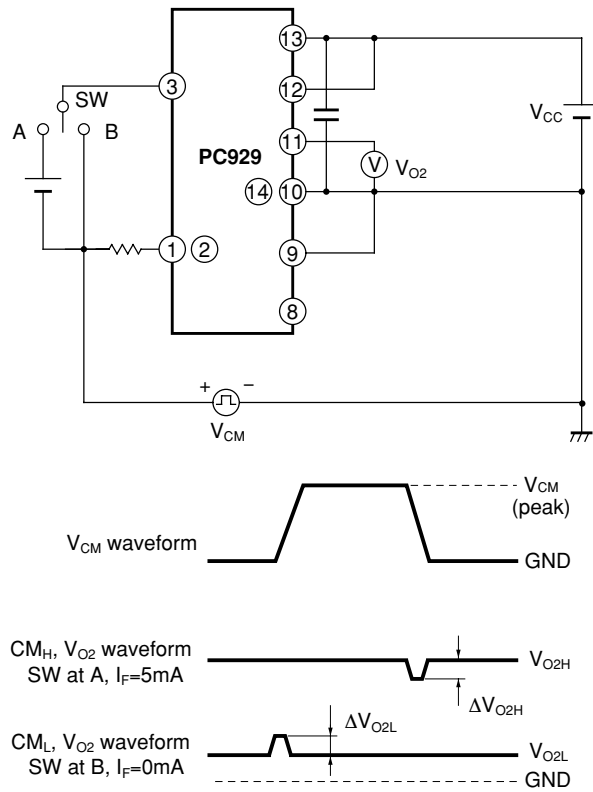

Fig.8 Test Circuit for Response Time

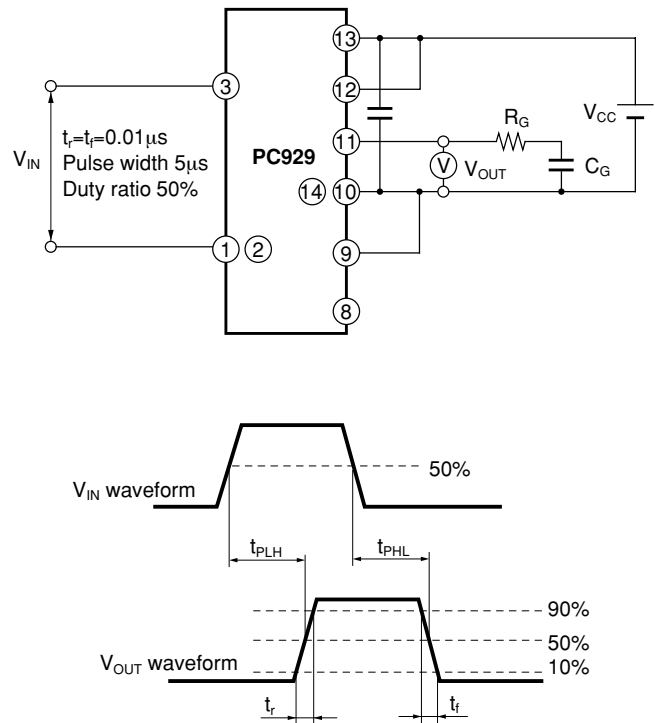

Fig.9 Test Circuit for Overcurrent Detection Voltage, Overcurrent Detection Voltage Hysteresis

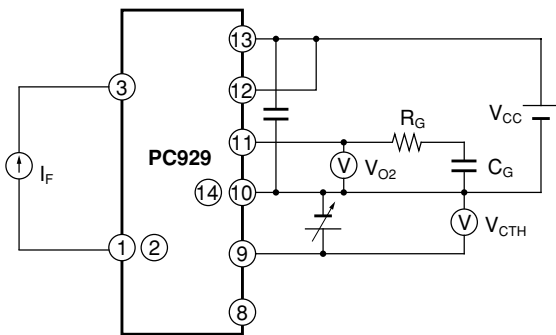

Fig.10 Test Circuit for O₂ Output Voltage at Overcurrent Protection

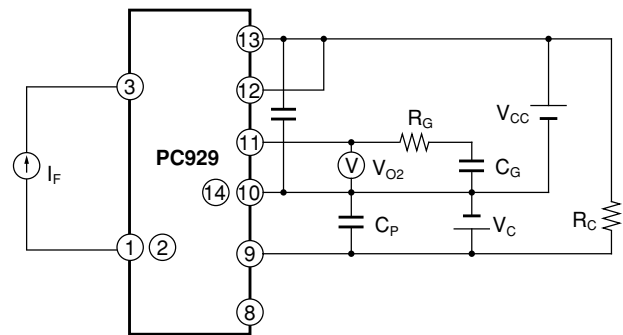

Fig.11 Test Circuit for O₁ Low Level Error Signal Voltage

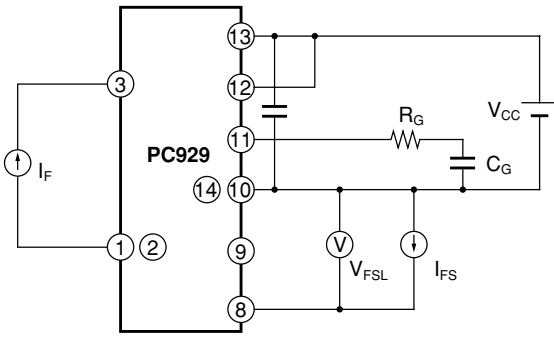

Fig.12 Test Circuit for High Level Error Signal Current

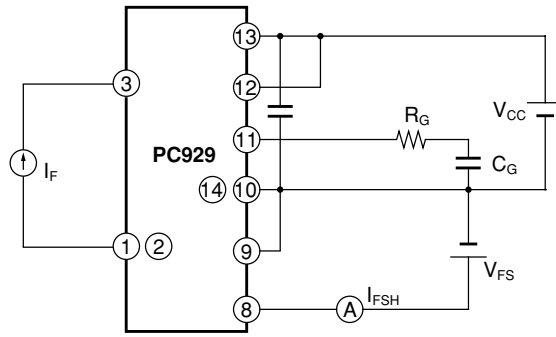

Fig.13 Test Circuit for O₂ "High→Low" Propagation Delay Time at Overcurrent Protection, O₂ Fall Time at Overcurrent Protection

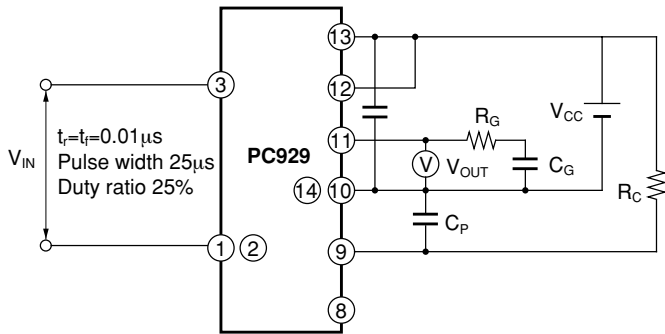

Fig.14 Error Signal "High→Low" propagation Delay Time, Error Signal Output Pulse Width

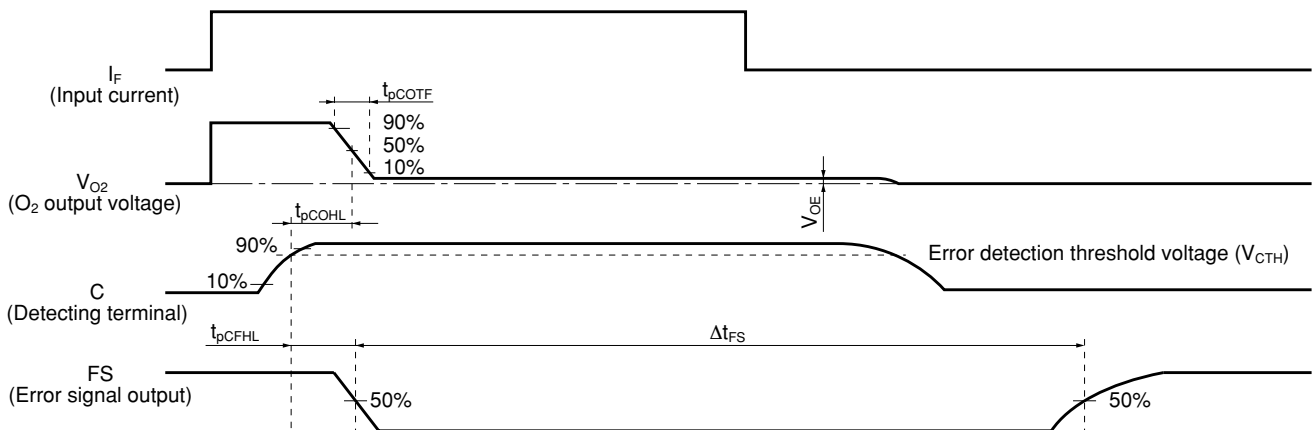
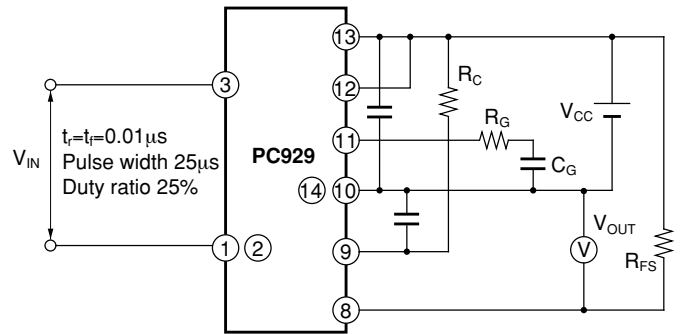

Fig.15 Forward Current vs. Ambient Temperature

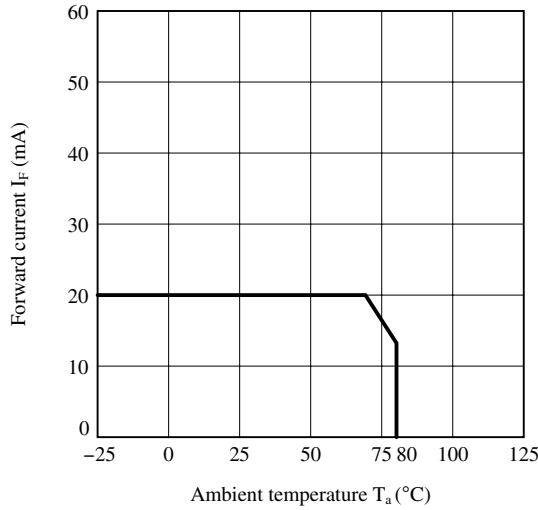

Fig.16 Power Dissipation vs. Ambient Temperature

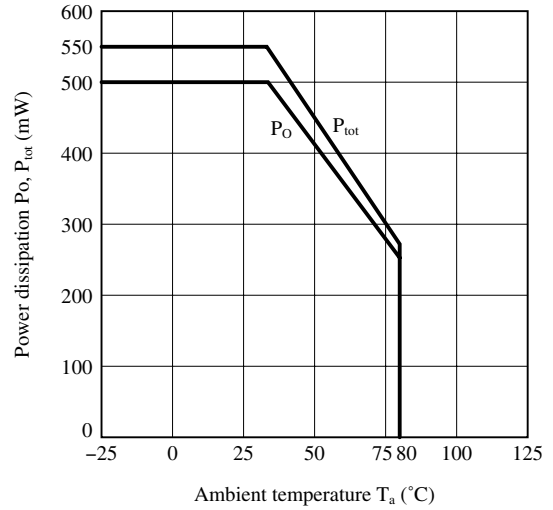

Fig.17 Forward Current vs. Forward Voltage

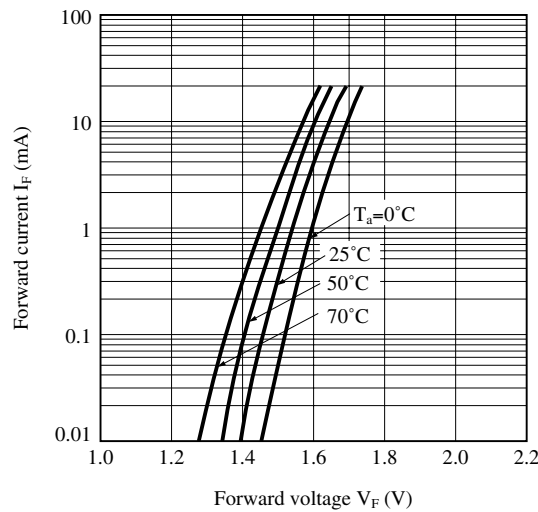

Fig.18 "Low→High" Relative Input Threshold Current vs. Supply Voltage

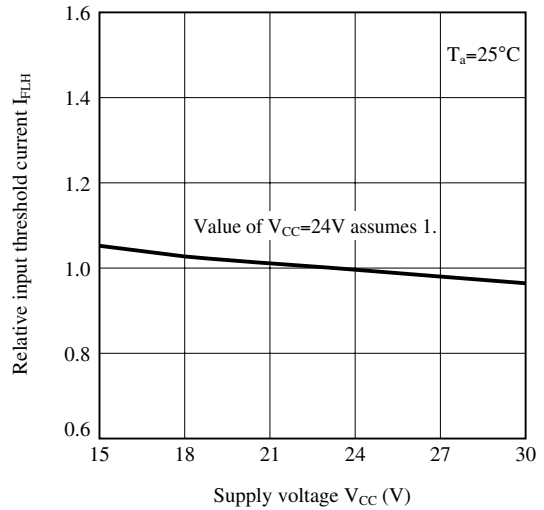

Fig.19 "Low→High" Relative Input Threshold Current vs. Ambient Temperature

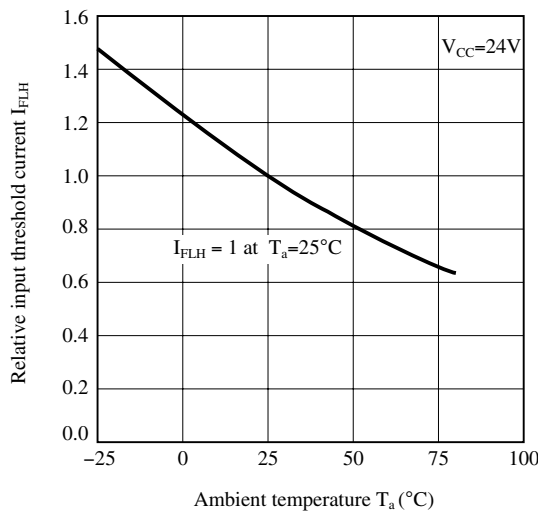

Fig.20 O₁ Low Level Output Voltage vs. O₁ Output Current

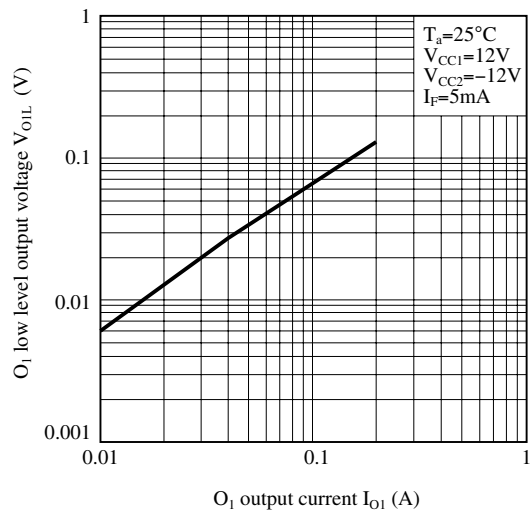

Fig.21 O₁ Low Level Output Voltage vs. Ambient Temperature

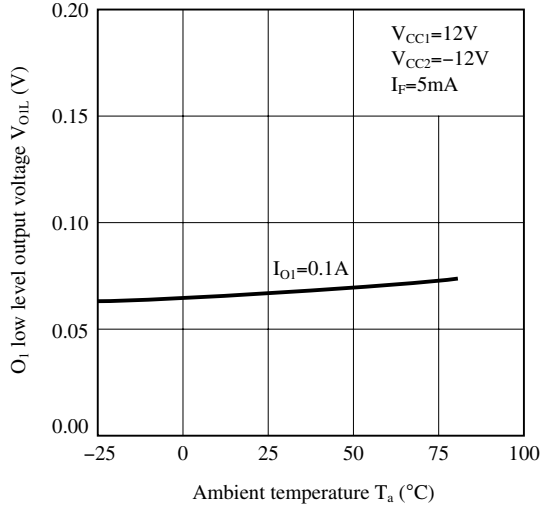

Fig.22 O₁ Leak Current vs. Ambient Temperature

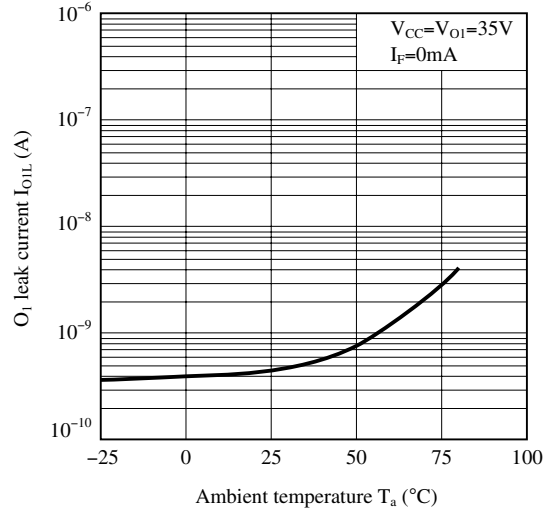

Fig.23 O₂ High Level Output Voltage vs. Supply Voltage

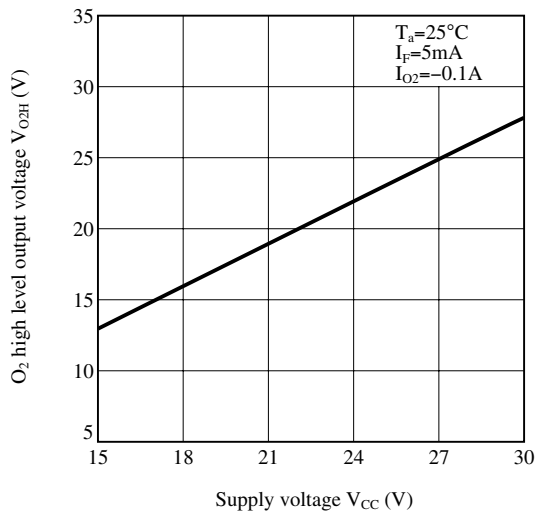

Fig.24 O₂ High Level Output Voltage vs. Ambient Temperature

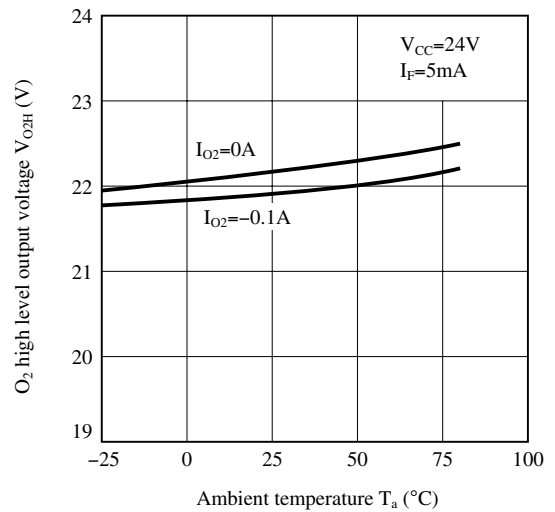

Fig.25 O₂ Low Level Output Voltage vs. O₂ Output Current

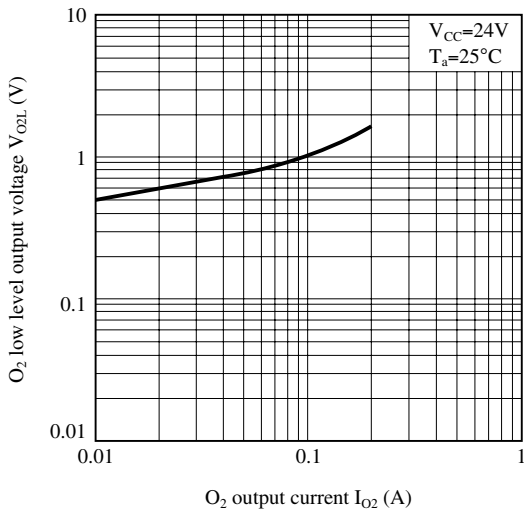

Fig.26 O₂ Low Level Output Voltage vs. Ambient Temperature

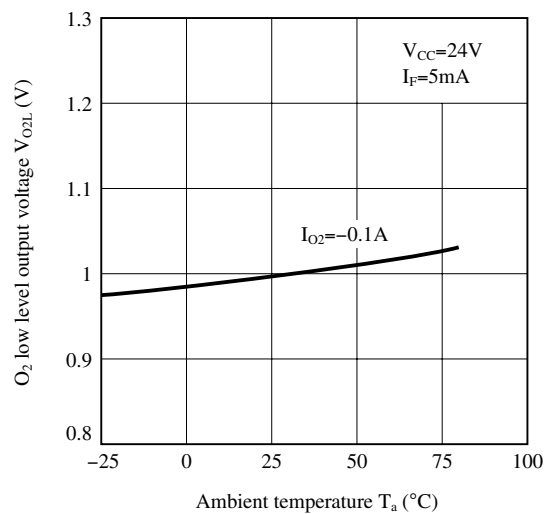

Fig.27 High Level Supply Current vs. Supply Voltage

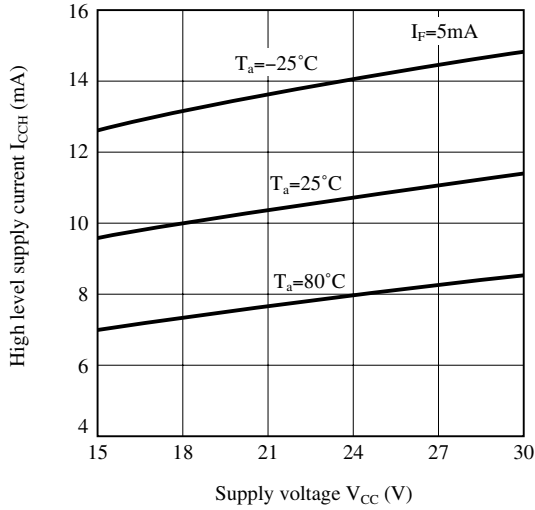

Fig.28 Low Level Supply Current vs. Supply Voltage

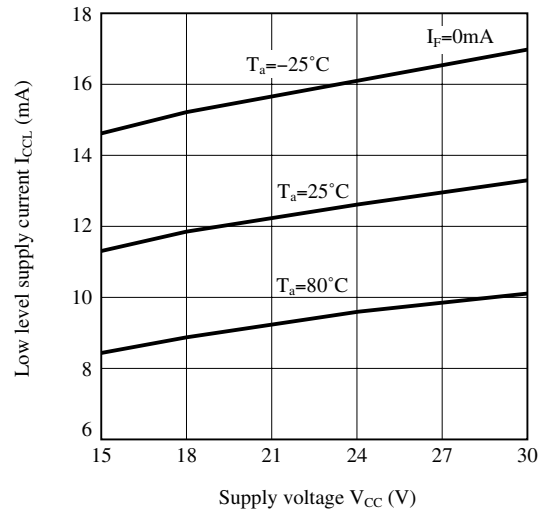

Fig.29 Propagation Delay Time vs. Forward Current

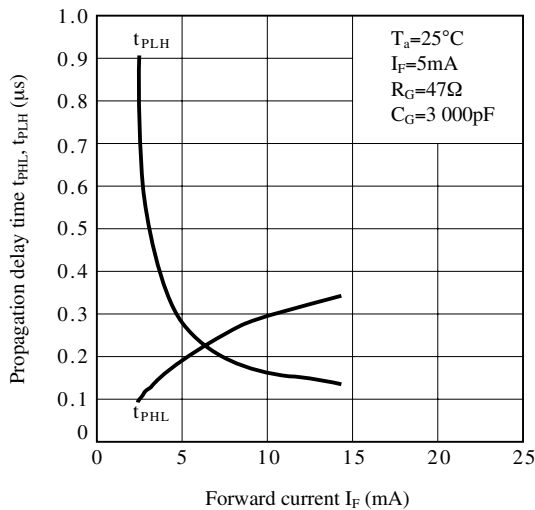

Fig.30 Propagation Delay Time vs. Ambient Temperature

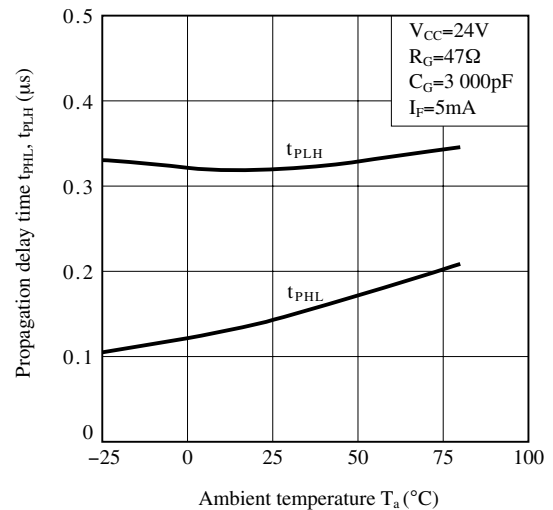

Fig.31 Overcurrent Detecting Voltage vs. Ambient Temperature

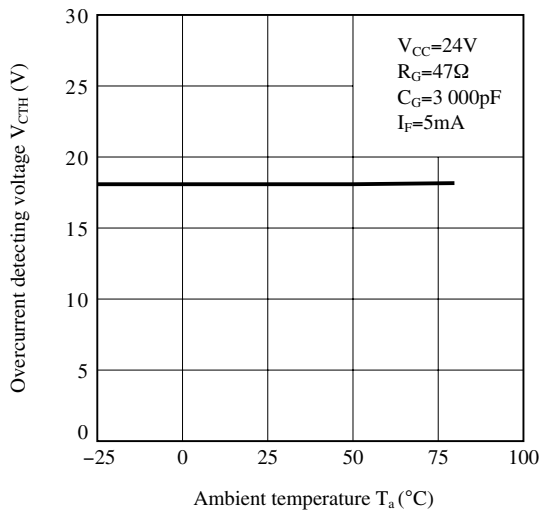

Fig.32 O₂ Output Fall Time at Protection from Overcurrent/O₂ "High-Low" Propagation Delay Time at Protection from Overcurrent vs. Ambient Temperature

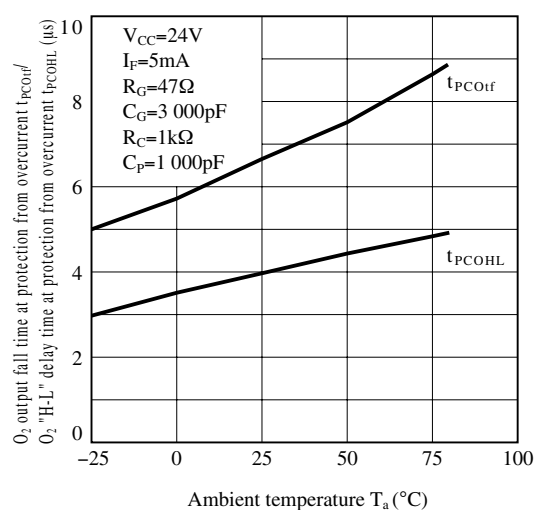

Fig.33 Error Signal "High-Low" Propagation Delay Time vs. Ambient Temperature

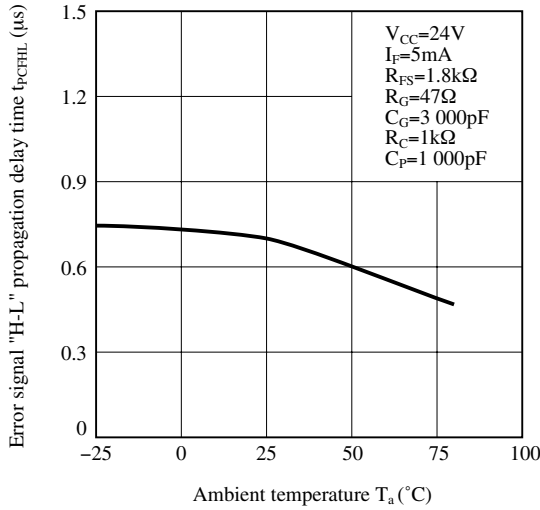

Fig.34 O_2 Output Voltage at Protection from Overcurrent vs. Ambient Temperature

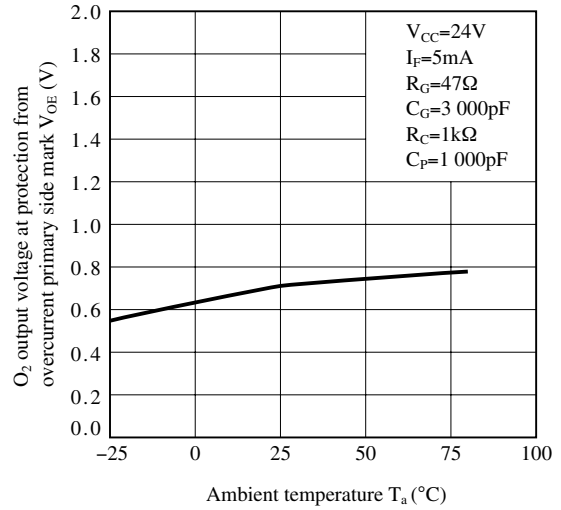

Fig.35 Low Level Error Signal Voltage vs. Ambient Temperature

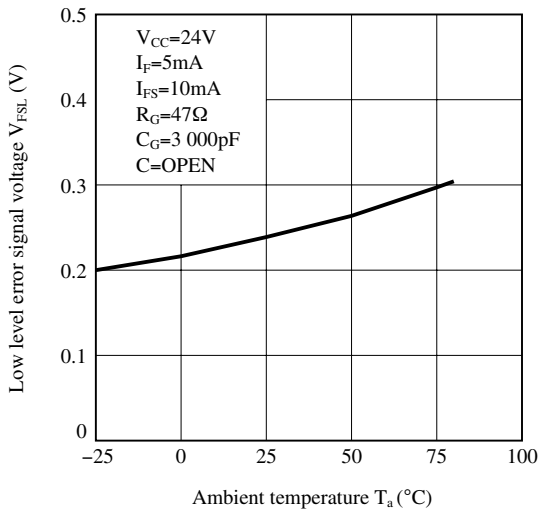

Fig.36 High Level Error Signal Current vs. Ambient Temperature

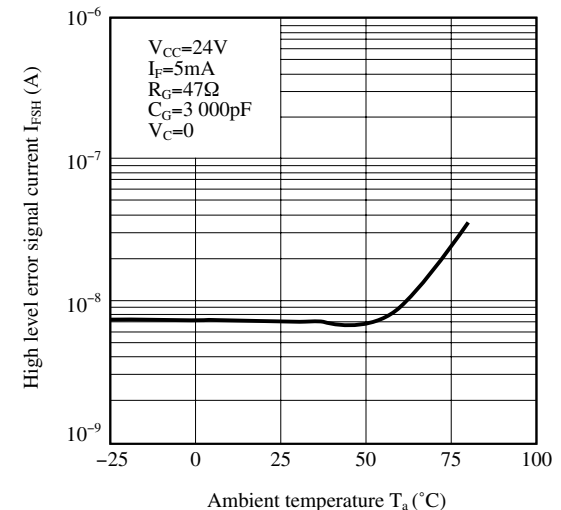

Fig.37 Error signal output pulse width vs. Ambient Temperature

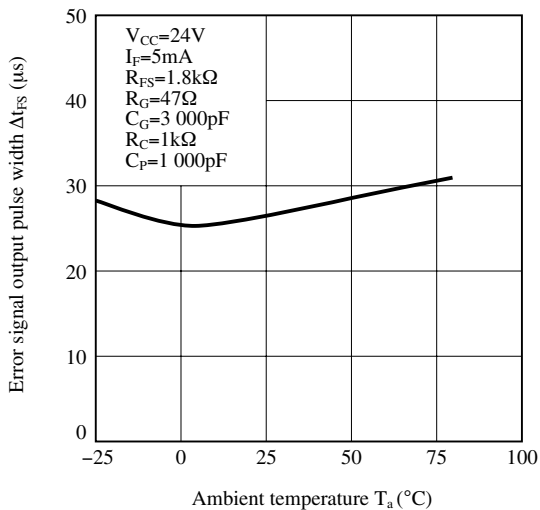

Fig.38 Overcurrent Detecting Voltage vs. Supply Voltage

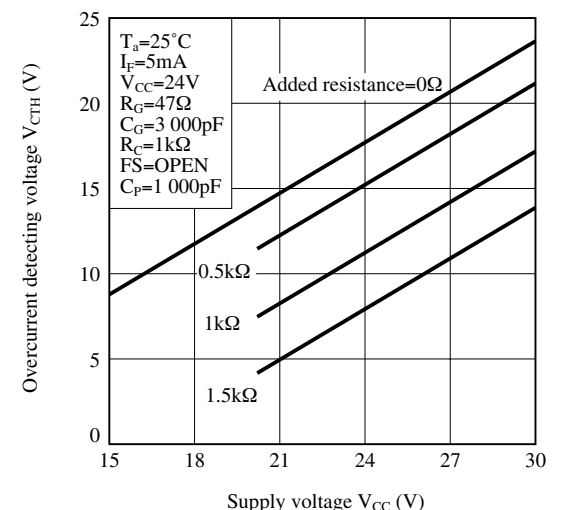

Fig.39 Overcurrent Detecting Voltage - Supply Voltage Characteristics Test Circuit

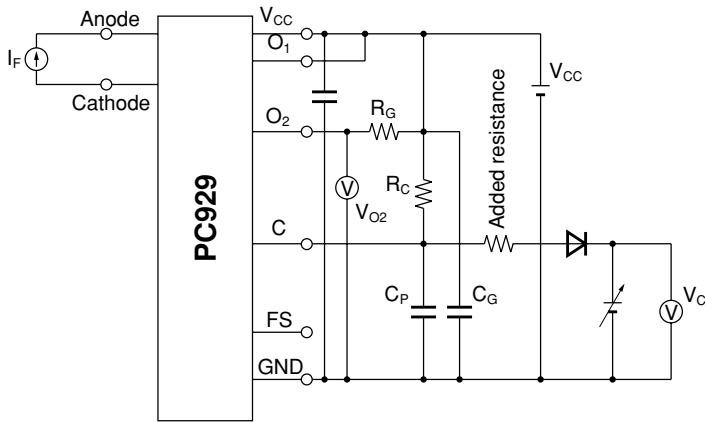
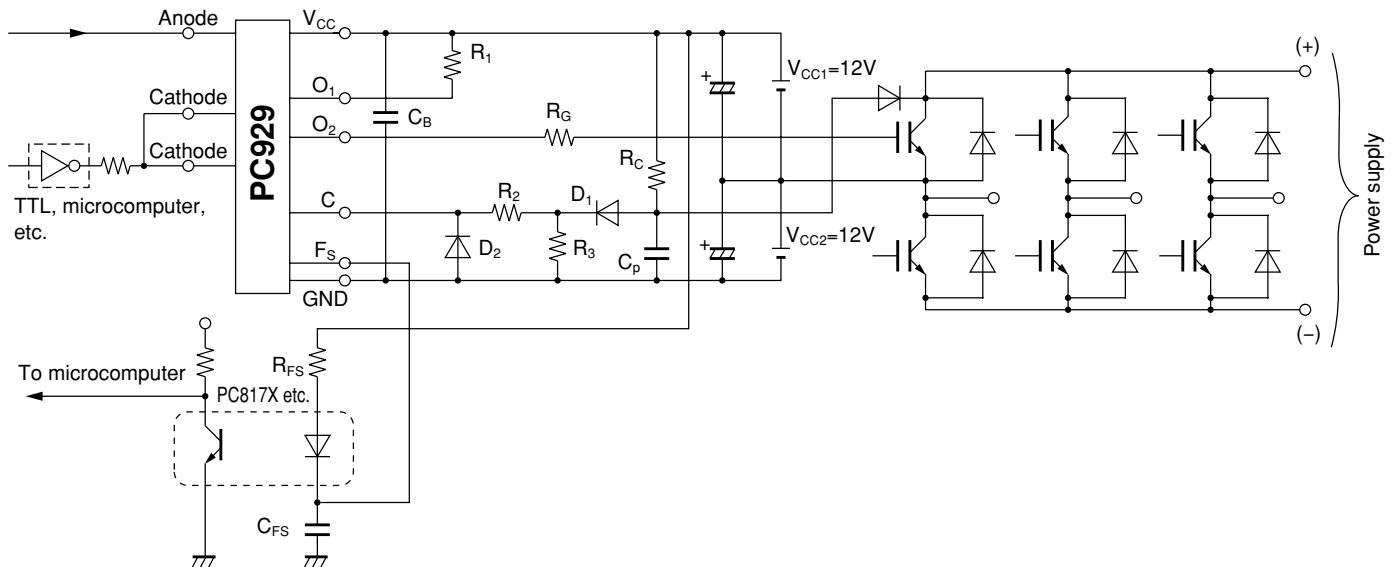

Fig.40 Example of The Application Circuit (IGBT Drive for Inverter)



- In order to stabilize the power supply line, we recommend to locate a bypass capacitor C_B (0.01 μ F or more) between V_{CC} and GND near photocoupler.
- In order to stabilize the detecting voltage of pin-C, we recommend to locate a capacitor C_P (approximately 1 000pF) between pin-C and GND, and a resistor R_C (approximately 1.0k Ω) between V_{CC} and pin-C. However, the rise time of the detection voltage at Pin-C varies along with the time constants of C_P and R_C . So, please make sure the device works properly in actual conditions.
- For the diode D, which is located between pin-C and collector of IGBT, we recommend to use a diode that has the withstand voltage characteristic equivalent to IGBT and also has little leak current.
- In order to prevent the failure mode or breakdown of pin-C from V_{CE} variation of IGBT, we recommend to locate a resistor R_2 (approximately 10k Ω) and a diode D1 at near pin-C, and a resistor R_3 (approximately 50k Ω) and a diode D2 at between pin-C and GND.

This application circuit shows the general example of a circuit, and is not a design guarantee for right operation.

■ Design Considerations

● Notes about static electricity

Transistor of detector side in bipolar configuration may be damaged by static electricity due to its minute design.

When handling these devices, general countermeasure against static electricity should be taken to avoid breakdown of devices or degradation of characteristics.

● Design guide

In order to stabilize power supply line, we should certainly recommend to connect a by-pass capacitor of 0.01 μ F or more between V_{CC} and GND near the device.

We recommend to use approximately 1 000pF of capacitor between C-pin and GND in order to prevent miss operation by noise.

In the case that capacitor is used approximately 1k Ω of resistance shall be recommended to use between V_{CC} and C-pin. However, the rise time of C-pin shall be changed by time constant of added CR, so that please use this device after confirmation.

In case that some sudden big noise caused by voltage variation is provided between primary and secondary terminals of photocoupler some current caused by it is floating capacitance may be generated and result in false operation since current may go through LED or current may change.

If the photocoupler may be used under the circumstances where noise will be generated we recommend to use the bypass capacitors at the both ends of LED.

The detector which is used in this device, has parasitic diode between each pins and GND.

There are cases that miss operation or destruction possibly may be occurred if electric potential of any pin becomes below GND level even for instant.

Therefore it shall be recommended to design the circuit that electric potential of any pin does not become below GND level.

This product is not designed against irradiation and incorporates non-coherent LED.

● **Degradation**

In general, the emission of the LED used in photocouplers will degrade over time.

In the case of long term operation, please take the general LED degradation (50% degradation over 5years) into the design consideration.

Please decide the input current which become 2times of MAX. I_{FLH} .

● **Recommended Foot Print (reference)**

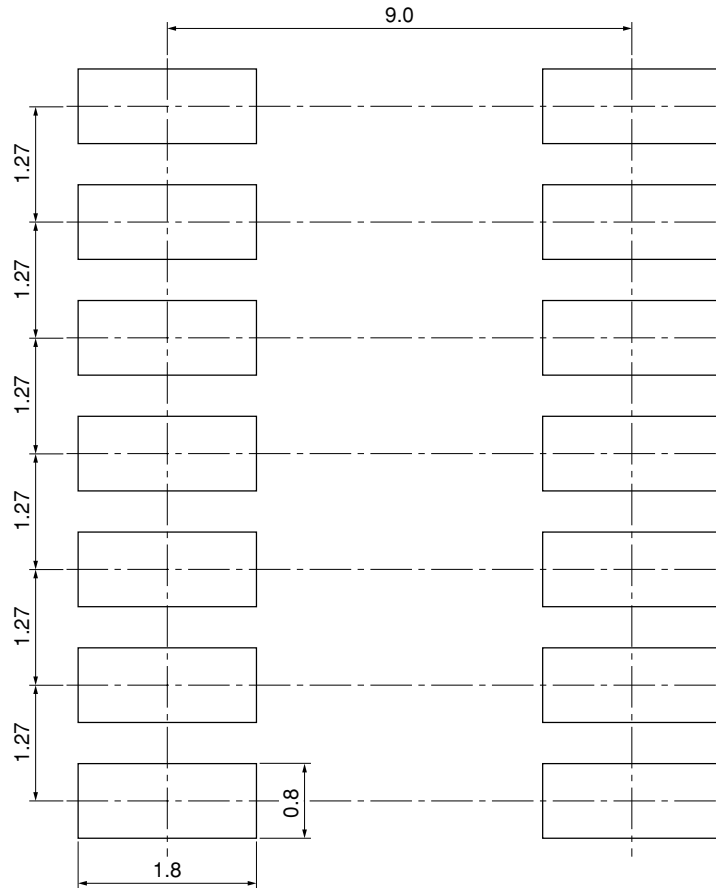

(Unit : mm)

☆ For additional design assistance, please review our corresponding Optoelectronic Application Notes.

■ Manufacturing Guidelines

● Soldering Method

Reflow Soldering:

Reflow soldering should follow the temperature profile shown below.

Soldering should not exceed the curve of temperature profile and time.

Please don't solder more than twice.

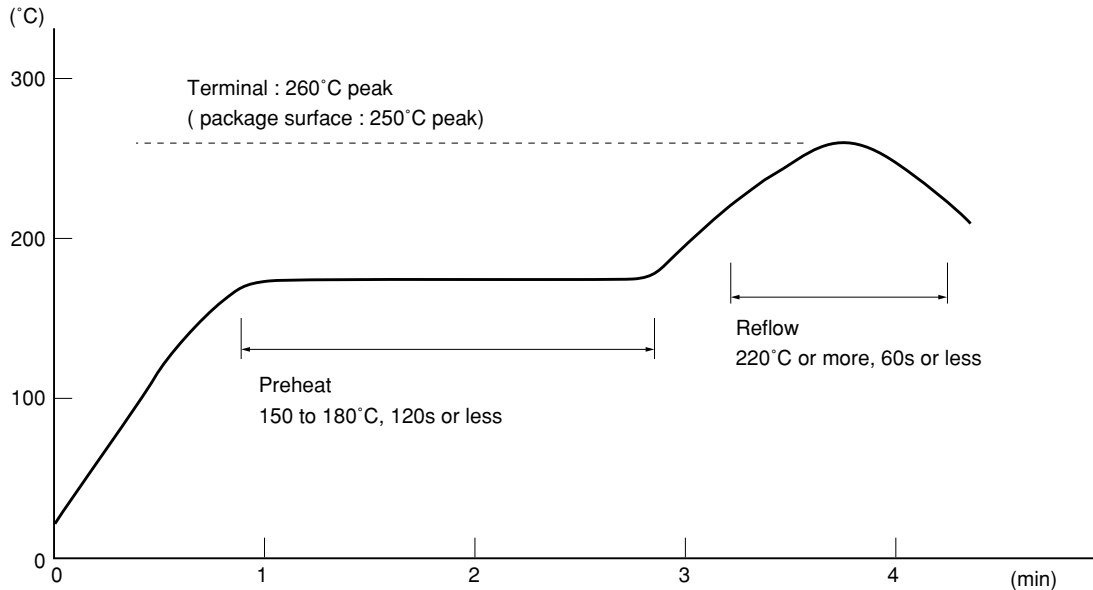

Flow Soldering :

Due to SHARP's double transfer mold construction submersion in flow solder bath is allowed under the below listed guidelines.

Flow soldering should be completed below 260°C and within 10s.

Preheating is within the bounds of 100 to 150°C and 30 to 80s.

Please don't solder more than twice.

Hand soldering

Hand soldering should be completed within 3s when the point of solder iron is below 400°C.

Please don't solder more than twice.

Other notices

Please test the soldering method in actual condition and make sure the soldering works fine, since the impact on the junction between the device and PCB varies depending on the tooling and soldering conditions.

● Cleaning instructions**Solvent cleaning:**

Solvent temperature should be 45°C or below Immersion time should be 3minutes or less

Ultrasonic cleaning:

The impact on the device varies depending on the size of the cleaning bath, ultrasonic output, cleaning time, size of PCB and mounting method of the device.

Therefore, please make sure the device withstands the ultrasonic cleaning in actual conditions in advance of mass production.

Recommended solvent materials:

Ethyl alcohol, Methyl alcohol and Isopropyl alcohol

In case the other type of solvent materials are intended to be used, please make sure they work fine in actual using conditions since some materials may erode the packaging resin.

● Presence of ODC

This product shall not contain the following materials.

And they are not used in the production process for this device.

Regulation substances : CFCs, Halon, Carbon tetrachloride, 1.1.1-Trichloroethane (Methylchloroform)

Specific brominated flame retardants such as the PBBOs and PBBs are not used in this product at all.

■ **Package specification**

● **Sleeve package**

Package materials

Sleeve : HIPS (with anti-static material)

Stopper : Styrene-Elastomer

Package method

MAX. 50 pcs. of products shall be packaged in a sleeve.

Both ends shall be closed by tabbed and tabless stoppers.

The product shall be arranged in the sleeve with its primary side mark on the tabless stopper side.

MAX. 20 sleeves in one case.

Sleeve outline dimensions

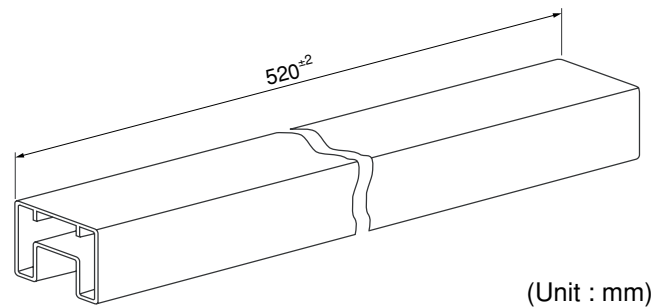
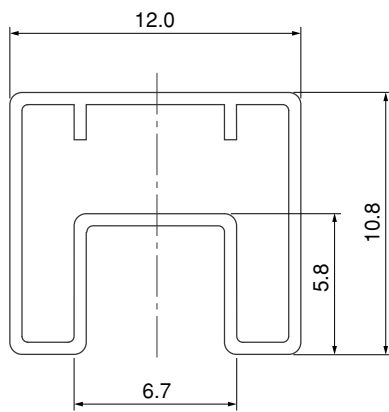

● **Tape and Reel package**

Package materials

Carrier tape : A-PET (with anti-static material)

Cover tape : PET (three layer system)

Reel : PS

Carrier tape structure and Dimensions

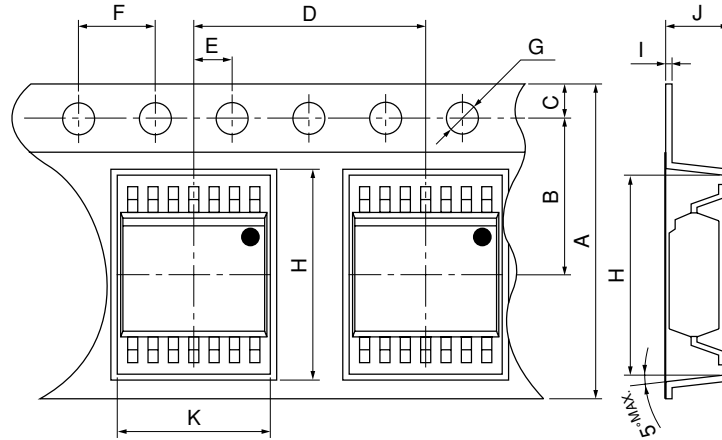

Dimensions List (Unit : mm)

A	B	C	D	E	F	G
16.0±0.3	7.5±0.1	1.75±0.1	12.0±0.1	2.0±0.1	4.0±0.1	φ1.5±0.1
H	I	J	K			
10.4±0.1	0.4±0.05	4.2±0.1	9.7±0.1			

Reel structure and Dimensions

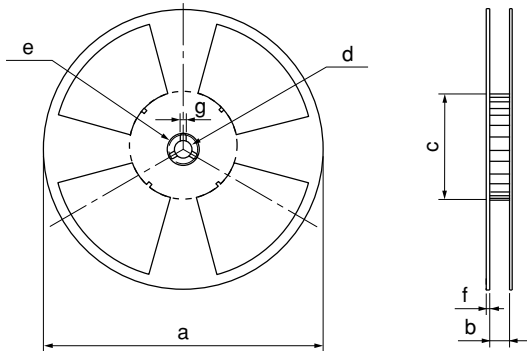

Dimensions List (Unit : mm)

a	b	c	d
330	17.5±1.5	100±1.0	13±0.5
e	f	g	
23±1.0	2.0±0.5	2.0±0.5	

Direction of product insertion

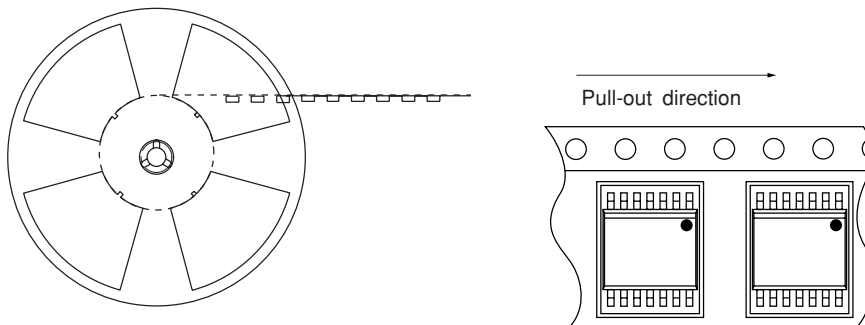

[Packing : 1 000pcs/reel]

■ Important Notices

· The circuit application examples in this publication are provided to explain representative applications of SHARP devices and are not intended to guarantee any circuit design or license any intellectual property rights. SHARP takes no responsibility for any problems related to any intellectual property right of a third party resulting from the use of SHARP's devices.

· Contact SHARP in order to obtain the latest device specification sheets before using any SHARP device. SHARP reserves the right to make changes in the specifications, characteristics, data, materials, structure, and other contents described herein at any time without notice in order to improve design or reliability. Manufacturing locations are also subject to change without notice.

· Observe the following points when using any devices in this publication. SHARP takes no responsibility for damage caused by improper use of the devices which does not meet the conditions and absolute maximum ratings to be used specified in the relevant specification sheet nor meet the following conditions:

(i) The devices in this publication are designed for use in general electronic equipment designs such as:

- Personal computers
- Office automation equipment
- Telecommunication equipment [terminal]
- Test and measurement equipment
- Industrial control
- Audio visual equipment
- Consumer electronics

(ii) Measures such as fail-safe function and redundant design should be taken to ensure reliability and safety when SHARP devices are used for or in connection

with equipment that requires higher reliability such as:

- Transportation control and safety equipment (i.e., aircraft, trains, automobiles, etc.)
- Traffic signals
- Gas leakage sensor breakers
- Alarm equipment
- Various safety devices, etc.

(iii) SHARP devices shall not be used for or in connection with equipment that requires an extremely high level of reliability and safety such as:

- Space applications
- Telecommunication equipment [trunk lines]
- Nuclear power control equipment
- Medical and other life support equipment (e.g., scuba).



· If the SHARP devices listed in this publication fall within the scope of strategic products described in the Foreign Exchange and Foreign Trade Law of Japan, it is necessary to obtain approval to export such SHARP devices.

· This publication is the proprietary product of SHARP and is copyrighted, with all rights reserved. Under the copyright laws, no part of this publication may be reproduced or transmitted in any form or by any means, electronic or mechanical, for any purpose, in whole or in part, without the express written permission of SHARP. Express written permission is also required before any use of this publication may be made by a third party.

· Contact and consult with a SHARP representative if there are any questions about the contents of this publication.

Looking for pricing, stock, or lifecycle information?

Click below to explore more details on WIN SOURCE:

-  [View PC929 on WIN SOURCE](#)
-  [Sharp Microelectronics Information](#)

Optimize Your Supply Chain with WIN SOURCE Solutions

-  Global Sourcing Solution
-  Obsolete Management
-  Cost Control Management
-  Shortage Management
-  Alternative Solution
-  Excess Inventory Management