

REFERENCE

SPEC. No. ED-09P022
ISSUE June 29, 2009

SHARP

SYSTEM DEVICE DIVISION I
ELECTRONIC COMPONENTS AND DEVICES GROUP
SHARP CORPORATION

SPECIFICATION

DEVICE SPECIFICATION FOR

PHOTOCOUPLER

MODEL No.

PC851

Business dealing name

PC851XNNSZ0F

PC851XNYSZ0F

Specified for

Enclosed please find copies of the Specifications which consists of 15 pages including cover.
This specification sheets and attached sheets shall be both side copy.
After confirmation of the contents, please be sure to send back copies of the Specifications
with approving signature on each.

CUSTOMER'S APPROVAL

DATE

BY

PRESENTED

DATE

June 29, 2009

BY

M. Imataka

for.

M. Kubo,
Department General Manager of
Development Dept. IV
System Device Div. I
Electronic Components and Devices Group
SHARP CORPORATION

Product name : PHOTOCOUPLER

Model No. : PC851

Business dealing name

PC851XNNSZ0F	PC851XNYSZ0F
--------------	--------------

1. These specification sheets include materials protected under copyright of Sharp Corporation ("Sharp"). Please do not reproduce or cause anyone to reproduce them without Sharp's consent.
2. When using this product, please observe the absolute maximum ratings and the instructions for use outlined in these specification sheets, as well as the precautions mentioned below. Sharp assumes no responsibility for any damage resulting from use of the product which does not comply with the absolute maximum ratings and the instructions included in these specification sheets, and the precautions mentioned below.

(Precautions)

- (1) This product is designed for use in the following application areas ;

· OA equipment	· Audio visual equipment	· Home appliances
· Telecommunication equipment (Terminal)	· Measuring equipment	
· Tooling machines	· Computers	

If the use of the product in the above application areas is for equipment listed in paragraphs (2) or (3), please be sure to observe the precautions given in those respective paragraphs.

- (2) Appropriate measures, such as fail-safe design and redundant design considering the safety design of the overall system and equipment, should be taken to ensure reliability and safety when this product is used for equipment which demands high reliability and safety in function and precision, such as ;

· Transportation control and safety equipment (aircraft, train, automobile etc.)	}
· Traffic signals · Gas leakage sensor breakers · Rescue and security equipment	
· Other safety equipment	

- (3) Please do not use this product for equipment which require extremely high reliability and safety in function and precision, such as ;

· Space equipment	· Telecommunication equipment (for trunk lines)	}
· Nuclear power control equipment	· Medical equipment	

- (4) Please contact and consult with a Sharp sales representative if there are any questions regarding interpretation of the above three paragraphs.

3. Please contact and consult with a Sharp sales representative for any questions about this product.

1. Application

This specification applies to the outline and characteristics of photocoupler Model No. PC851(Lead-Free Type).

2. Outline Refer to the attached sheet, page 4.

3. Ratings and characteristics Refer to the attached sheet, page 5, 6.

4. Reliability Refer to the attached sheet, page 7.

5. Outgoing inspection Refer to the attached sheet, page 8.

6. Supplement

6.1 Isolation voltage shall be measured in the following method.

- (1) Short between anode and cathode on the primary side and between collector and emitter on the secondary side.
- (2) The dielectric withstanding tester with zero-cross circuit shall be used.
- (3) The wave form of applied voltage shall be a sine wave.
(It is recommended that the isolation voltage be measured in insulation oil.)

6.2 Package specifications Refer to the attached sheet, page 9, 10.

6.3 Business dealing name

("O" mark indicates business dealing name of ordered product)

Product	Business dealing name	Remark
	PC851XNNSZ0F	
	PC851XNYSZ0F	Applied to product as a option (Attachment-2-1 to 2-3.)

6.4 This Model is approved by UL.

Approved Model No. : PC851

UL file No. : E64380

6.5 This product is not designed against irradiation.

This product is assembled with electrical input and output.

This product incorporates non-coherent light emitting diode.

6.6 ODS materials

This product shall not contain the following materials.

Also, the following materials shall not be used in the production process for this product.

Materials for ODS : CFC_s, Halon, Carbon tetrachloride, 1.1.1-Trichloroethane (Methyl chloroform)

6.7 Specified brominated flame retardants

Specified brominated flame retardants (PBB and PBDE) are not used in this device at all.

6.8 Compliance with each regulation

(1) The RoHS directive (2002/95/EC)

This product complies with the RoHS directive (2002/95/EC).

Object substances: mercury, lead, cadmium, hexavalent chromium, polybrominated biphenyls (PBB) and polybrominated diphenyl ethers (PBDE)

(2) Content of six substances specified in Management Methods for Control of Pollution Caused by Electronic Information Products Regulation (Chinese : 电子信息产品污染控制管理办法).

Category	Toxic and hazardous substances					
	Lead (Pb)	Mercury (Hg)	Cadmium (Cd)	Hexavalent chromium (Cr ⁶⁺)	Polybrominated biphenyls (PBB)	Polybrominated diphenyl ethers (PBDE)
Photocoupler	✓	✓	✓	✓	✓	✓

✓: indicates that the content of the toxic and hazardous substance in all the homogeneous materials of the part is below the concentration limit requirement as described in SJ/T 11363-2006 standard .

7. Notes

Precautions for Photocouplers : Attachment-1.

PC851XNNSZ0F REFERENCE

2. Outline

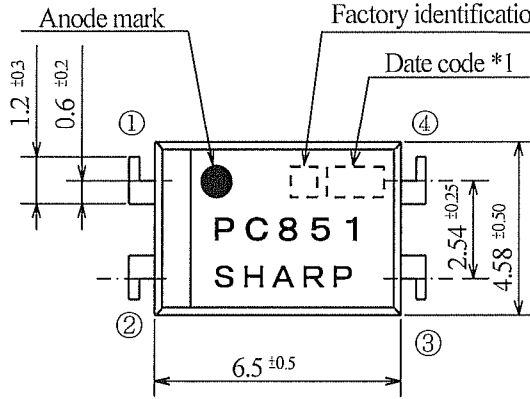

Pin-Number and internal connection diagram

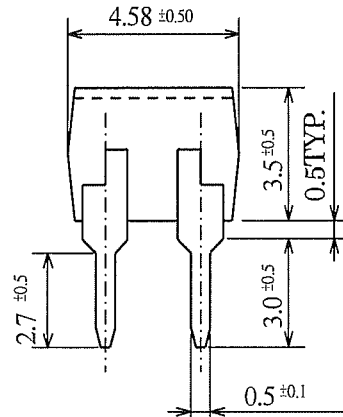
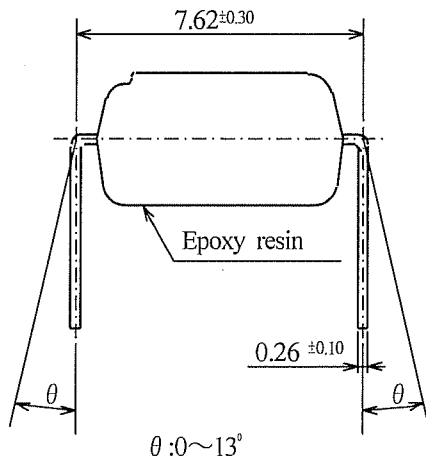
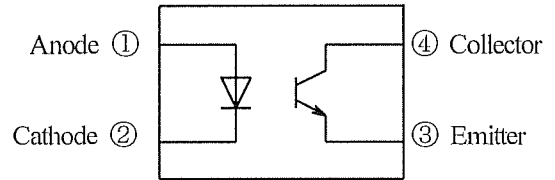

*1) 2-digit number shall be marked according to OLD DIN standard.

*2) Factory identification mark applies to the below.

: WUXI WONDERFUL ELECTRONICS CO. LTD. (China)

or : SUN-S Electronic Technology (KUNSHAN) Co., Ltd (China)

Pin material : Copper Alloy

Pin finish : SnCu plating (Cu : TYP. 2%)

Product mass : Approx.0.23g

Marking is laser marking

UNIT : 1/1 mm

Name	PC851 Outline Dimensions (Business dealing name : PC851XNNSZ0F)
------	--

3. Ratings and characteristics

3.1 Absolute maximum ratings

$T_a=25^{\circ}\text{C}$

Parameter		Symbol	Rating	Unit
Input	*1 Forward current	I_F	50	mA
	*2 Peak forward current	I_{FM}	1	A
	Reverse voltage	V_R	6	V
	*1 Power dissipation	P	70	mW
Output	Collector-emitter voltage	V_{CEO}	350	V
	Emitter-collector voltage	V_{ECO}	6	V
	Collector current	I_c	50	mA
	*1 Collector power dissipation	P_c	150	mW
*1 Total power dissipation	P_{tot}	200	mW	
Operating temperature		T_{opr}	-25 to +100	$^{\circ}\text{C}$
Storage temperature		T_{stg}	-55 to +125	$^{\circ}\text{C}$
*3 Isolation voltage	$V_{iso(ms)}$	5	kV	
*4 Soldering temperature	T_{sol}	270	$^{\circ}\text{C}$	

3.2 Electro-optical characteristics

$T_a=25^{\circ}\text{C}$

Parameter		Symbol	Condition	MIN.	TYP.	MAX.	Unit
Input	Forward voltage	V_F	$I_F=20\text{mA}$	-	1.2	1.4	V
	Reverse current	I_R	$V_R=4\text{V}$	-	-	10	μA
	Terminal capacitance	C_t	$V=0, f=1\text{kHz}$	-	30	250	pF
Output	Dark current	I_{CEO}	$V_{CE}=200\text{V}, I_F=0$	-	-	1	μA
	Collector-emitter breakdown voltage	BV_{CEO}	$I_c=0.1\text{mA}, I_F=0$	350	-	-	V
	Emitter-collector breakdown voltage	BV_{ECO}	$I_E=10\mu\text{A}, I_F=0$	6	-	-	V
Transfer characteristics	Collector current	I_c	$I_F=5\text{mA}, V_{CE}=5\text{V}$	2.0	4.0	-	mA
	Collector-emitter saturation voltage	$V_{CE(sat)}$	$I_F=20\text{mA}, I_c=1\text{mA}$	-	0.1	0.3	V
	Isolation resistance	R_{ISO}	DC500V 40 to 60%RH	5×10^{10}	10^{11}	-	Ω
	Floating capacitance	C_f	$V=0, f=1\text{MHz}$	-	0.6	1.0	pF
	Cut-off frequency	f_c	$V_{CE}=5\text{V}, I_c=2\text{mA}$ $R_L=100\Omega, -3\text{dB}$	-	50	-	kHz
	Rise time	t_r	$V_{CE}=2\text{V}, I_c=2\text{mA}$ $R_L=100\Omega$	-	4	10	μs
Fall time	t_f	-		5	12	μs	

*1 The derating factors of absolute maximum ratings due to ambient temperature are shown in Fig. 1 to 4.

*2 Pulse width $\leq 100\mu\text{s}$, Duty ratio : 0.001 (Refer to Fig. 5)

*3 AC for 1 min, 40 to 60%RH

*4 For 10 s

(Fig. 1) Forward current vs. ambient temperature

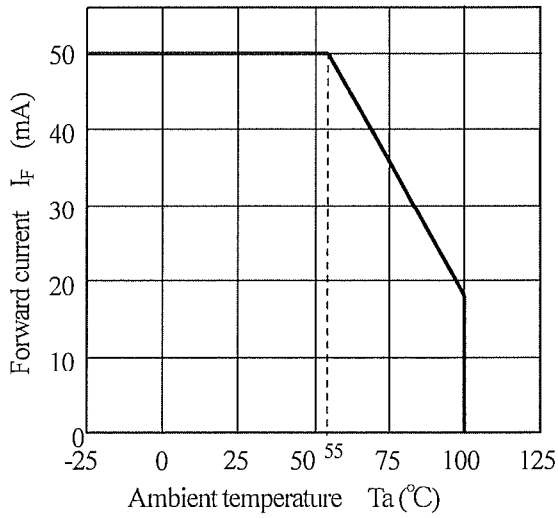

(Fig. 2) Diode power dissipation vs. ambient temperature

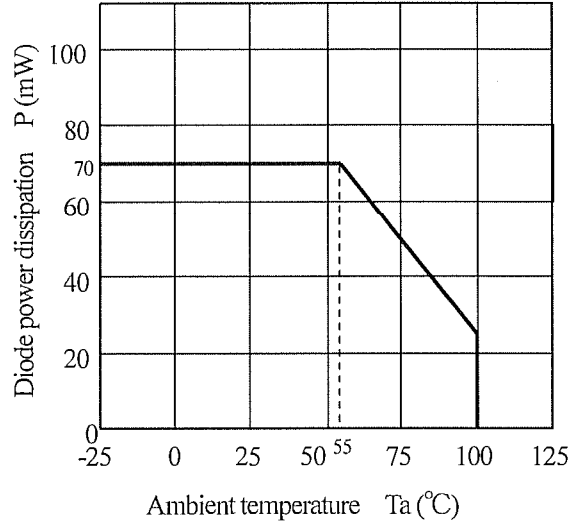

(Fig. 3) Collector power dissipation vs. ambient temperature

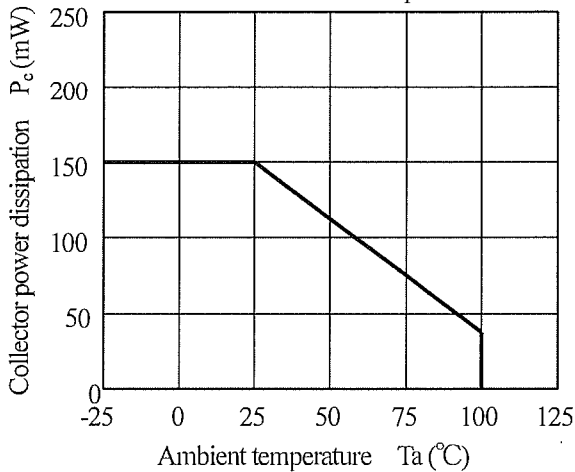

(Fig. 4) Total power dissipation vs. ambient temperature

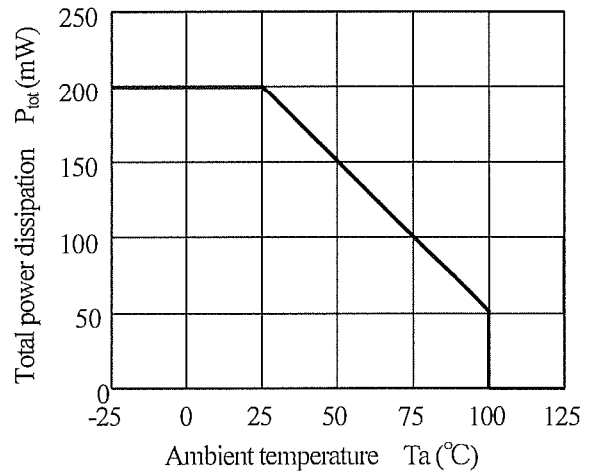

(Fig. 5) Peak forward current vs. duty ratio
 Pulse width $\leq 100\mu s$
 $T_a = 25^\circ C$

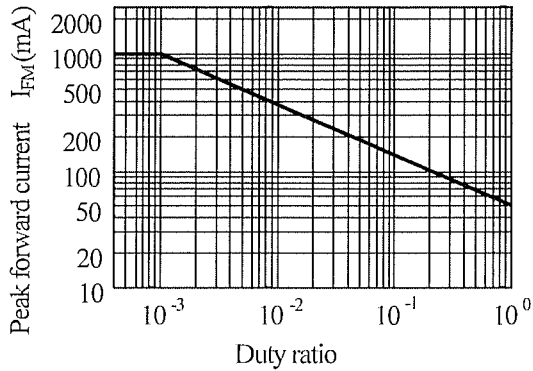

4. Reliability

The reliability of products shall satisfy items listed below.

Confidence level : 90%

LTPD : 10or20

Test Items	Condition *1	Failure Judgment Criteria	Samples (n) Defective (C)
Solderability	245±3°C, 5s	*2	n=11, C=0
Soldering heat	(Flow soldering) 270°C, 10 s	$V_F > U \times 1.2$ $I_R > U \times 2$ $I_{CEO} > U \times 2$ $I_C < L \times 0.7$ $V_{CE(sat)} > U \times 1.2$ U: Upper specification limit L: Lower specification limit	n=11, C=0
	(Soldering by hand) 400°C, 3 s		n=11, C=0
Terminal strength (Tension)	Weight: 5N 5 s/each terminal		n=11, C=0
Terminal strength (Bending) *3	Weight: 2.5N 2 times/each terminal		n=11, C=0
Mechanical shock	15km/s ² , 0.5ms 3 times/±X, ±Y, ±Z direction		n=11, C=0
Variable frequency vibration	100 to 2000 to 100Hz/4 min 200m/s ² 4 times/X, Y, Z direction		n=11, C=0
Temperature cycling	1 cycle -55 °C to +125 °C (30 min) (30 min) 20 cycles test		n=22, C=0
High temp. and high Humidity storage	+85°C, 85%RH, 1000h		n=22, C=0
High temp. storage	+125 °C, 1000h		n=22, C=0
Low temp. storage	-55 °C, 1000h		n=22, C=0
Operation life	I _F =50mA, P _{tot} =200mW T _a =25 °C, 1000h		n=22, C=0

*1 Test method, conforms to EIAJ ED 4701.

*2 The product whose not-soldered area is more than 5% for all of the dipped area, and/or whose pinholes or voids are concentrated on one place shall be judged defect.

*3 Terminal bending direction is shown below.

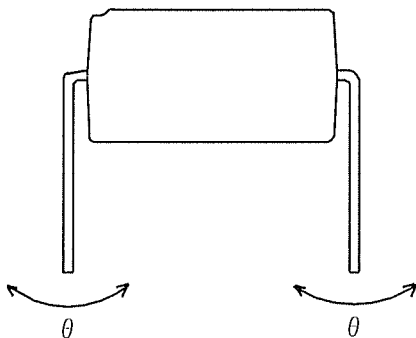

5. Outgoing inspection

5.1 Inspection items

(1) Electrical characteristics

 $V_F, I_R, I_{CEO}, V_{CE(sat)}, I_C, R_{ISO}, V_{ISO}$

(2) Appearance

5.2 Sampling method and Inspection level

A single sampling plan, normal inspection level II based on ISO 2859 is applied.

The AQL according to the inspection items are shown below.

Defect	Inspection item	AQL (%)
Major defect	Electrical characteristics Unreadable marking	0.065
Minor defect	Appearance defect except the above mentioned.	0.25

6.2 Package specification

6.2.1 Package materials

No.	Name	Materials	Purposes
①	Sleeve	HIPS or ABS with preventing static electricity	Products packaged
②	Stopper	Styrene-Erastomer	Products fixed
③	Packing case	Corrugated cardboard	Sleeve packaged
④	Kraft tape	Paper	Lid of packing case fixed
⑤	Label	Paper	Model No.,(Business dealing name),Lot No., Quantity, country of origin , Company name and inspection date specified

6.2.2 Package method

- (1) MAX. 100pcs. of products shall be packaged in a sleeve ① and both of sleeve edges shall be fixed by stoppers ②.
- (2) MAX. 20 sleeves (Product : 2000pcs.) above shall be packaged in a packing case ③.
- (3) The label ⑤ shall be put on the side of the packing case.
- (4) Case shall be closed with the lid and enclosed with kraft tape ④.

6.2.3 Sleeve ① outline dimensions

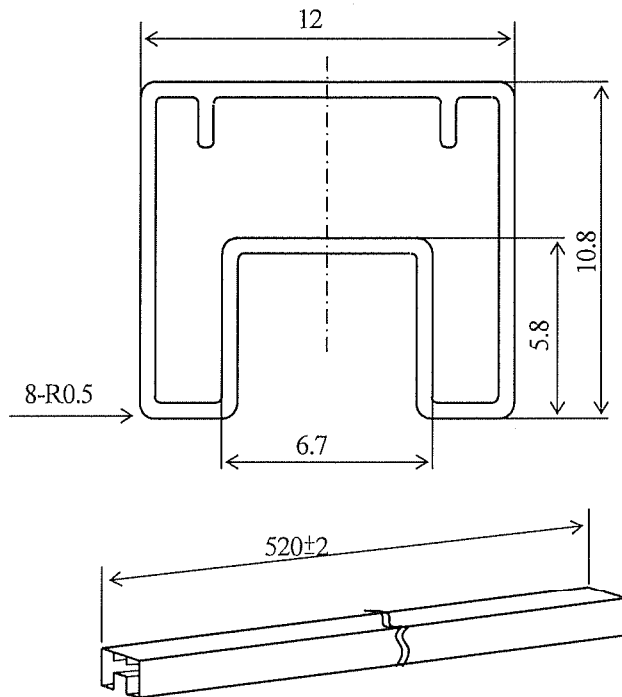

(Unit :mm)

- Note
- 1) Thickness : 0.5 ± 0.2 mm
 - 2) Process with applying antistatic agent.
 - 3) Unless otherwise specified tolerances shall be ± 0.5 mm.
(However except for deformation due to the stopper in sleeve.)

PC851X1NSZ0F
REFERENCE

6.2.4 Packaging case outline dimensions

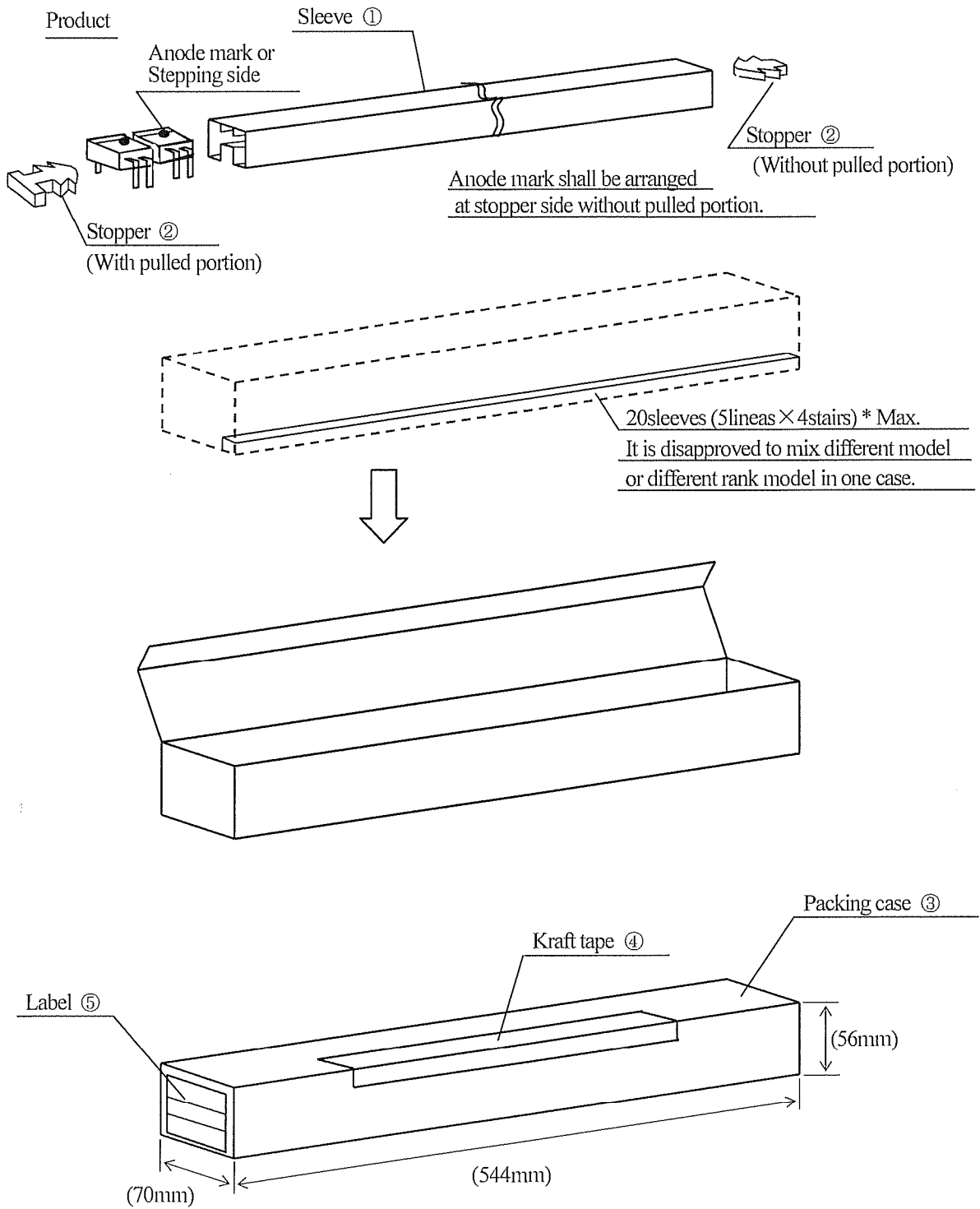

Regular packing mass : Approx. 860g

() : Reference dimensions

Precautions for Photocouplers

1 Cleaning

- (1) Solvent cleaning : Solvent temperature 45°C or less
Immersion for 3 min or less
- (2) Ultrasonic cleaning : The effect to device by ultrasonic cleaning differs by cleaning bath size, ultrasonic power output, cleaning time, PCB size or device mounting condition etc. Please test it in actual using condition and confirm that any defect doesn't occur before starting the ultrasonic cleaning.
- (3) Applicable solvent : Ethyl alcohol, Methyl alcohol, Isopropyl alcohol
When the other solvent is used, there are cases that the packaging resin is eroded.
Please use the other solvent after thorough confirmation is performed in actual using condition.

2. Circuit design

- 2.1 The LED used in the Photocoupler generally decreases the light emission power by operation.
In case of long operation time, please design the circuit in consideration of the degradation of the light emission power of the LED.(50%/5years)
- 2.2 There are cases that the deviation of the CTR and the degradation of the relative light emission power of the LED increase when the setting value of $I_F < 1.0\text{mA}$. Please design the circuit in consideration of this point.

3. Precautions for Soldering

- (1) In the case of flow soldering (Whole dipping is possible)
It is recommended that flow soldering should be at 270°C or less for 10 s or less (Pre-heating : 100 to 150°C, 30 to 80s).
(2 times or less)
- (2) In the case of hand soldering
What is done on the following condition is recommended.(2 times or less)
Soldering iron temperature : 400°C or less
Time : 3s or less
- (3) Other precautions
Depending on equipment and soldering conditions (temperature, Using solder etc.), the effect to the device and the PCB is different.
Please confirm that there is no problem on the actual use conditions in advance.

PC851XNYSZ0F REFERENCE

1. This specification shall be applied to photocoupler, Model No. PC851 as an option.
2. Applicable Models (Business dealing name)
PC851XNYSZ0F
3. The relevant models are the models Approved by VDE according to DIN EN 60747-5-2.
Approved Model No. : PC851
VDE approved No. : 40008087 (According to the specification DIN EN 60747-5-2)
 - Operating isolation voltage U_{IORM} : 890V (Peak)
 - Transient voltage : 9000V (Peak)
 - Pollution : 2
 - Clearances distance (Between input and output) : 6.4 mm (MIN.)
 - Creepage distance (Between input and output) : 6.4 mm (MIN.)
 - Isolation thickness between input and output : 0.15mm (MIN.)
 - Tracking-proof : CTI 175
 - Safety limit values
 - Current (I_{si}) : 200mA (Diode side)
 - Power (P_{si}) : 300mW (Phototransistor side)
 - Temperature (T_{si}) : 150°C

In order to keep safety electric isolation of photocoupler, please set the protective circuit to keep within safety limit values when the actual application equipment troubled.

- Indication of VDE approval prints "  " on minimum unit package.

4. Outline Refer to the attachment-2-2.

5. Isolation specification according to EN 60747-5-2.

Parameter	Symbol	Condition	Rating	Unit	Remark									
Class of environmental test	-	-	55/110/21	-										
Pollution	-	-	2	-										
Maximum operating isolation voltage	U_{IORM} (PEAK)	-	890	V	Refer to the Diagram 1,2 (Attachement-2-3)									
Partial discharge test voltage (Between input and output)														
<table border="1" style="width: 100%; border-collapse: collapse;"> <tr> <td style="width: 50%;">Diagram 1</td> <td style="width: 10%;">U_{pr} (PEAK)</td> <td style="width: 30%;">tp=10s, qc<5pC</td> <td style="width: 10%;">1340</td> <td style="width: 10%;">V</td> </tr> <tr> <td>Diagram 2</td> <td></td> <td>tp=1s, qc<5pC</td> <td>1670</td> <td>V</td> </tr> </table>	Diagram 1	U_{pr} (PEAK)	tp=10s, qc<5pC	1340		V	Diagram 2		tp=1s, qc<5pC	1670	V			
Diagram 1	U_{pr} (PEAK)	tp=10s, qc<5pC	1340	V										
Diagram 2		tp=1s, qc<5pC	1670	V										
Maximum over-voltage	U_{IOTM} (PEAK)	t _{INT} =60 s	9000	V										
Safety maximum ratings					Refer to Fig 6,7 (Attachement-2-3)									
1) Case temperature	T _{si}	I _F =0, P _C =0,	150	°C										
2) Input current	I _{si}	P _C =0	200	mA										
3) Electric power (Output or Total power dissipation)	P _{si}	-	300	mW										
Isolation resistance (Test voltage between input and output ; DC500V)	R _{ISO}	T _a =T _{si}	MIN.10 ⁹	Ω										
		T _a =T _{opr} (MAX.)	MIN.10 ¹¹											
		T _a =25°C	MIN.10 ¹²											

6. Precautions in performing isolation test

6.1 Partial discharge test methods shall be the ones according to the specifications of EN 60747-5-2

6.2 Please don't carry out isolation test (V_{iso}) over U_{IOTM}. This product deteriorates isolation characteristics by partial discharge due to applying high voltage (ex. U_{IOTM}).

And there is possibility that partial discharge occurs in operating isolation voltage. (U_{IORM}).

PC851XNYSZ0F REFERENCE

4. Outline

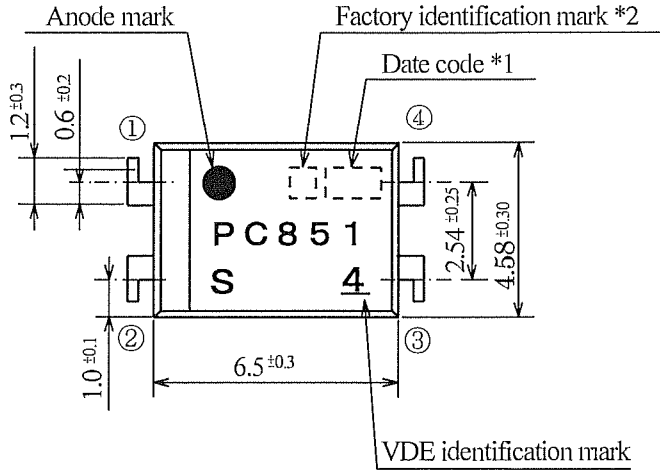

Pin-Number and internal connection diagram

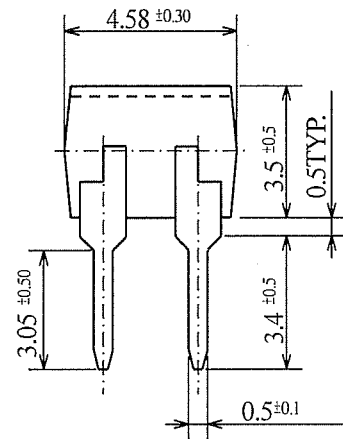
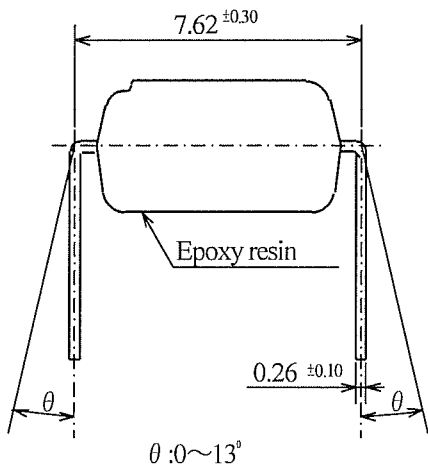
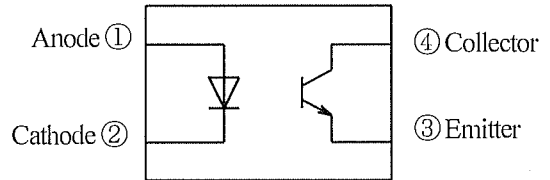

*1) 2-digit number shall be marked according to OLD DIN standard

*2) Factory identification mark applies to the below.

 : WUXI WONDERFUL ELECTRONICS CO. LTD. (China)

 or  : SUN-S Electronic Technology (KUNSHAN) Co., Ltd (China)

Pin material : Copper Alloy

Pin finish : SnCu plating (Cu : TYP. 2%)

Product mass : Approx. 0.23 g

Marking is laser marking

UNIT : 1/1 mm	
Name	Outline Dimensions PC851 (Business dealing name : PC851XNYSZ0F)

Method of Diagram 1: Breakdown test (Apply to type test and sampling test)

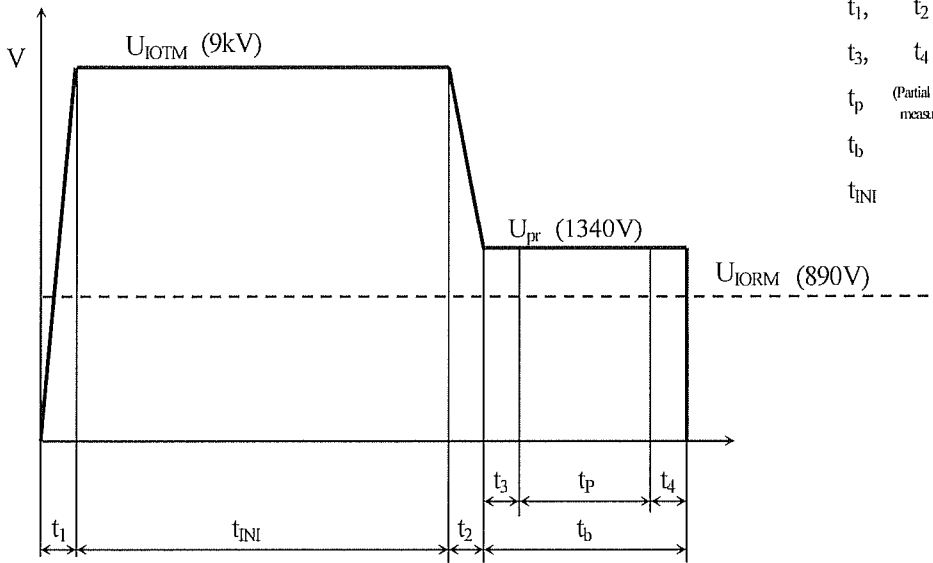

t_1, t_2	= 1 to 10 s
t_3, t_4	= 1 s
t_p (Partial discharge measuring time)	= 10 s
t_b	= 12 s
t_{INI}	= 60 s

Method of Diagram 2: Non breakdown test (Apply to all device test)

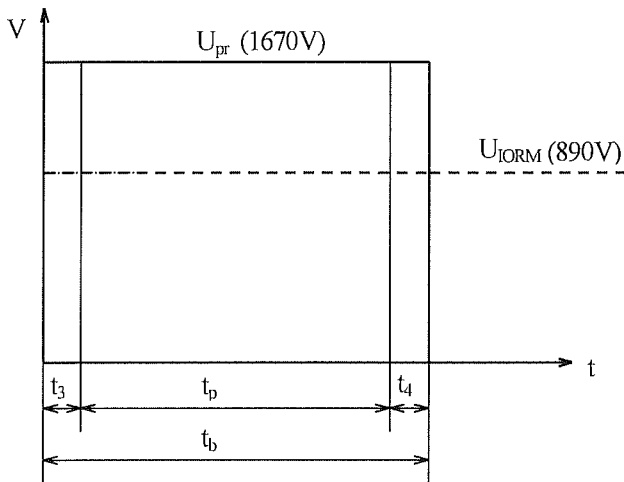

t_3, t_4	= 0.1 s
t_p (Partial discharge measuring time)	= 1 s
t_b	= 1.2 s

(Fig.6) Safety maximum power dissipation vs. ambient temperature (When failed)

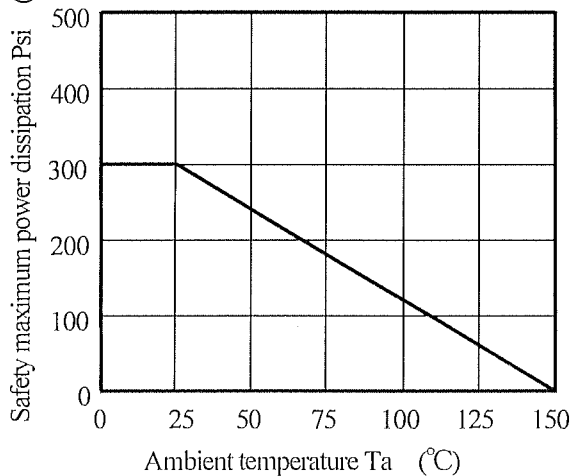

(Fig. 7) Safety maximum forward current vs. ambient temperature (When failed)

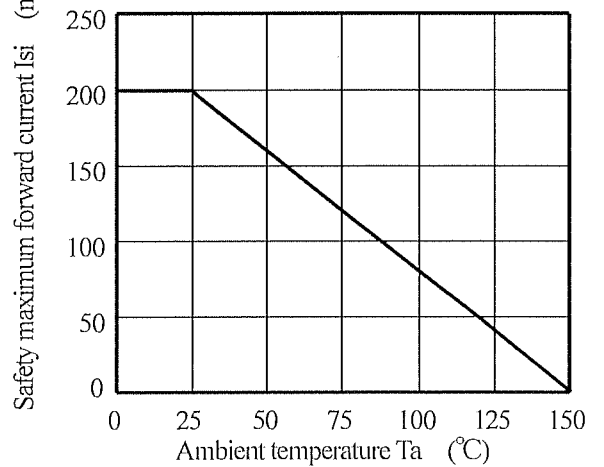

Looking for pricing, stock, or lifecycle information?

Click below to explore more details on WIN SOURCE:

- ⊖ [View PC851XNNSZ0F](#) on WIN SOURCE
- ⊖ [Sharp Microelectronics](#) Information

Optimize Your Supply Chain with WIN SOURCE Solutions

- ✓ Global Sourcing Solution
- ✓ Obsolete Management
- ✓ Cost Control Management
- ✓ Shortage Management
- ✓ Alternative Solution
- ✓ Excess Inventory Management