



THE DATASHEET OF PC3Q64



PREPARED BY: DATE <i>H. Takakura Apr 17 1993</i>	<h1>SHARP</h1> ELECTRONIC COMPONENTS GROUP SHARP CORPORATION <h2>SPECIFICATION</h2>	SPEC No. ED-93032
APPROVED BY: DATE <i>J. Yamakawa Apr 19 1993</i>		FILE No.
		ISSUE April 9, 1993
		PAGE 12 Pages
		REPRESENTATIVE DIVISION <input type="checkbox"/> PHOTOVOLTAICS DIV. <input checked="" type="checkbox"/> OPTO-ELECTRONIC DEVICES DIV. <input type="checkbox"/> ELECTRONIC COMPONENTS DIV. <input type="checkbox"/> <input type="checkbox"/>

DEVICE SPECIFICATION FOR
PHOTOCOUPLER

MODEL No. PC3Q64

1. This specification sheets include the contents under the copyright of Sharp Corporation ("Sharp"). Please keep them with reasonable care as important information. Please don't reproduce or cause anyone reproduce them without Sharp's consent.
2. Please obey the instructions mentioned below for actual use of this device.
 - (1) This device is designed for general electronic equipment.
Main uses of this device are as follows;

· Computer · OA equipment · Telecommunication equipment (Terminal)
· Measuring equipment · Tooling machine · AV equipment
· Home appliance, etc.
 - (2) Please take proper steps in order to maintain reliability and safety, in case this device is used for the uses mentioned below which require high reliability.

· Unit concerning control and safety of a vehicle (air plane, train, automobile etc.) · Gas leak detection breaker · Traffic signal
· Fire box and burglar alarm box · Other safety equipment, etc.
 - (3) Please don't use for the uses mentioned below which require extremely high reliability

· Space equipment · Telecommunication equipment (Trunk)
· Nuclear control equipment · Medical equipment (relating to any fatal element), etc.

CUSTOMER'S APPROVAL

DATE _____

BY _____

PRESENTED BY *T. Matsumura*

T. Matsumura,
Department General Manager of
Engineering Dept., II
Opto-Electronic Devices Div.
ELECOM Group
SHARP CORPORATION

SHARP

1. Application

This specification applies to the outline and characteristics of photocoupler Model No. PC3Q64.

2. Outline

Refer to the attached drawing No. CY5888K02.

3. Ratings and characteristics

3.1 Absolute maximum ratings

Ta=25°C

Parameter		Symbol	Rating	Unit
Input	*1 Forward current	I _F	±50	mA
	*2 Peak forward current	I _{FM}	±1	A
	*1 Power dissipation	P	70	mW
Output	Collector-emitter voltage	V _{CEO}	35	V
	Emitter-collector voltage	V _{ECO}	6	V
	Collector current	I _c	50	mA
	*1 Collector power dissipation	P _c	150	mW
*1 Total power dissipation		P _{tot}	170	mW
Operating temperature		T _{opr}	-30 ~ +100	°C
Storage temperature		T _{stg}	-40 ~ +125	°C
*3 Isolation voltage		V _{iso}	2.5	kV _{rms}
*4 Soldering temperature		T _{sol}	260	°C

*1 The derating factors of absolute maximum rating due to ambient temperature are shown in Fig. 1 ~ 4.

*2 Pulse width ≤ 100μs, Duty ratio : 0.001 (Refer to Fig. 5)

*3 AC for 1 min., 40 ~ 60%RH, f=60Hz

*4 For 10 s

SHARP

3.2 Electro-optical characteristics

Ta=25°C

Parameter		Symbol	MIN.	TYP.	MAX.	Unit	Conditions
Input	Forward voltage	V_F	-	1.2	1.4	V	$I_F = \pm 20\text{mA}$
	Terminal capacitance	C_t	-	30	250	pF	$V=0, f=1\text{kHz}$
Output	Dark current	I_{CEO}	-	-	100	nA	$V_{CE}=20\text{V}, I_F=0$
	Collector-emitter breakdown voltage	BV_{CEO}	35	-	-	V	$I_c=0.1\text{mA}$ $I_F=0$
	Emitter-collector breakdown voltage	BV_{ECO}	6	-	-	V	$I_E=10\mu\text{A}, I_F=0$
Transfer characteristics	Collector current	I_c	0.2	-	4.0	mA	$I_F = \pm 1\text{mA}$ $V_{CE}=5\text{V}$
	Collector-emitter saturation voltage	$V_{CE(\text{sat})}$	-	0.1	0.2	V	$I_F = \pm 20\text{mA}$ $I_c=1\text{mA}$
	Isolation resistance	R_{iso}	5×10^{10}	10^{11}	-	Ω	DC500V 40 ~ 60%RH
	Floating capacitance	C_f	-	0.6	1.0	pF	$V=0, f=1\text{MHz}$
	Response time (Rise)	t_r	-	4	18	μs	$V_{CE}=2\text{V}$ $I_c=2\text{mA}$
	Response time (Fall)	t_f	-	3	18	μs	$R_L=100\Omega$

SHARP

4. Reliability

Refer to the attached sheet, Page 7.

5. Incoming inspection

Refer to the attached sheet, Page 8.

6. Supplements

6.1 Isolation voltage shall be measured in the following method.

- (1) Short between anode and cathode on the primary side and between collector and Emitter on the secondary side.
- (2) The dielectric withstand tester with zero-cross circuit shall be used.
- (3) The waveform of applied voltage shall be a sine wave.
(It is recommended that the isolation voltage be measured in insulation oil)

6.2 This product is AC input type.

6.3 (1) This product is not designed as radiation hardened.

- (2) This product is assembled with electrical input and output.
- (3) This product incorporates non coherent light emitting diode.

6.4 Package specifications

Refer to the attached sheet, Page 9 to 11.

6.5 UL : Under preparation

SHARP

7. Notes

7.1 For cleaning

* Cleaning conditions:

- (1) Solvent cleaning: Solvent temperature 45°C or less
Immersion 3 min. or less
- (2) Ultrasonic cleaning: Affection to device by ultrasonic cleaning has different affection by cleaning bath size, ultrasonic power output, cleaning time, PWB size or device mounting condition etc. If user carries out ultrasonic cleaning, user should select fit condition that doesn't occur defect.

* The cleaning shall be carried out with solvent below.

Solvent: Ethyl alcohol, Methyl alcohol, Isopropyl alcohol
Freon TE·TF, Daiflon-solvent S3-E

Please refrain from using Chloro Fluoro Carbon type solvent to clean devices as much as possible since it is restricted to protect the ozonosphere. Before you use alternative solvent you are requested to confirm that it does not damage package resin.

7.2 On mounting

In mounting this device, please perform soldering reflow satisfied with the conditions indicated in page 12. And please pay attention not to occur the temperature rising of the package sectionally.

8. Others

Any doubt as to this specification shall be determined in good faith upon mutual consultation of the both parties.

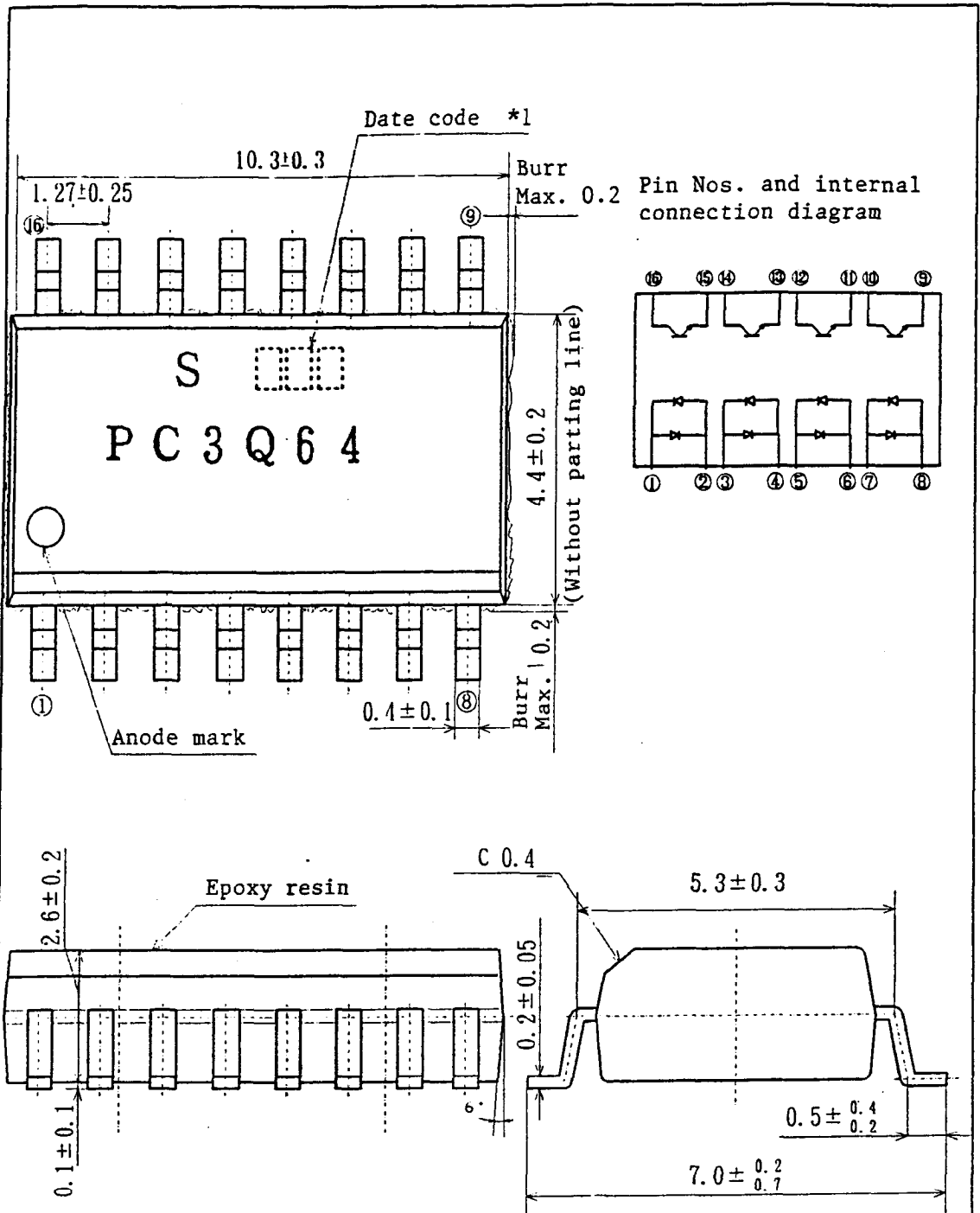

*1) Date code is composed of 2-digit number marked according to DIN standard and the following weekly code .

- First week : 1
- Second week : 2
- Third week : 3
- Fourth week : 4
- Fifth, Sixth week : 5

UNIT : 1 / 1 mm	
Name	PC3Q64 Outline Dimensions
Drawing No.	CY5888K02

Fig. 1 Forward current vs. ambient temperature

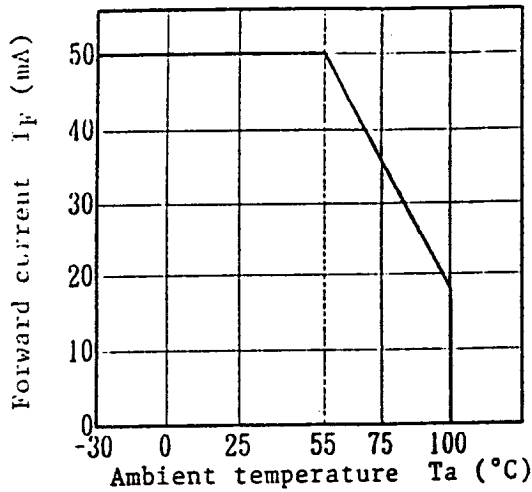

Fig. 2 Diode power dissipation vs. ambient temperature

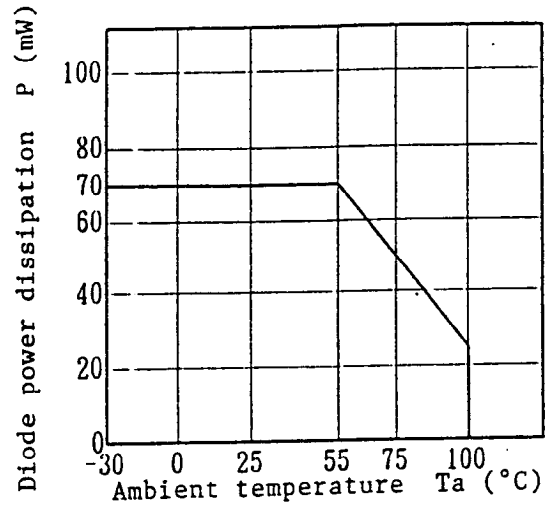

Fig. 3 Collector power dissipation vs. ambient temperature

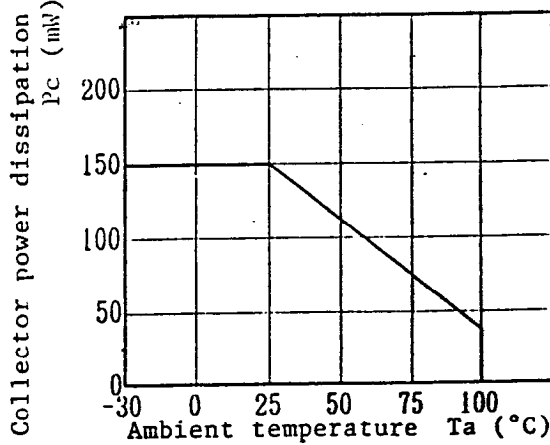

Fig. 4 Total power dissipation vs. ambient temperature

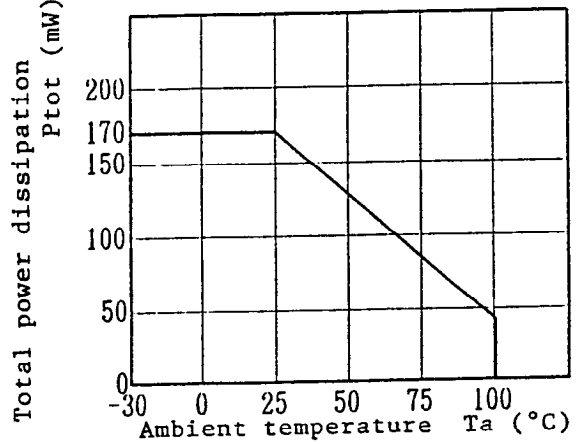
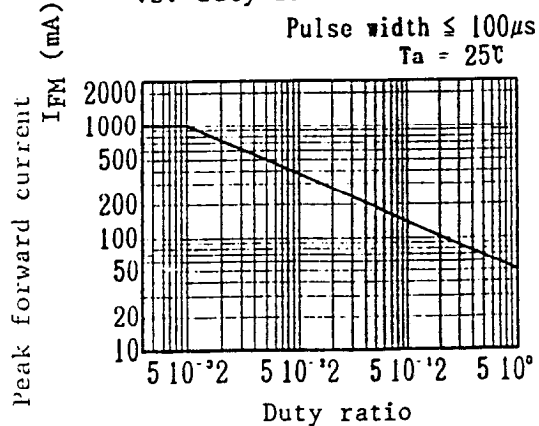

Fig. 5 Peak forward current vs. duty ratio



SHARP

4. Reliability

The reliability of products shall be satisfied with items listed below.

Confidence level : 90%, LTPD : 10%/20%

Test Items	Test Conditions	Failure Judgement Criteria	Samples (n) Defective(C)
Solderability *1	230°C, 5 s		n=11, C=0
Soldering heat *2	260°C, 10 s		n=11, C=0
Terminal strength (Bending) *3	Weight : 1N{0.1kgf} 1 time/each terminal	$V_F > U \times 1.2$	n=11, C=0
Mechanical shock	15000m/s ² {1500G}, 0.5ms 3 times/±X, ±Y, ±Z direction	$I_{CEO} > U \times 2$ $I_c < L \times 0.7$	n=11, C=0
Variable frequency vibration	100 ~ 2000 ~ 100 Hz/4 min. 4 times/X,Y,Z direction 200m/s ² {20G}	$V_{CE(sat)} > U \times 1.2$	n=11, C=0
Temperature cycling	1 cycle -40°C ~ +125°C (30min.) (30min.) 20 cycle test		n=22, C=0
High temp. and high humidity storage	+85°C, 85%RH, 500h	U: Upper specification limit	n=22, C=0
High temp. storage	+125°C, 1000h		n=22, C=0
Low temp. storage	-40°C, 1000h	L: Lower specification limit	n=22, C=0
Operation life	Ta=25°C, I _F =±50mA Ptot=170mW, 1000h		n=22, C=0

*1 Solder shall adhere at the area of 95% or more of immersed portion of lead and pin hole or other holes shall not be concentrated on one portion.

*2 The lead pin depth dipped into solder shall be away 0.2mm from the root of lead pins. (Refer to the below)

*3 Terminal bending direction is shown below.

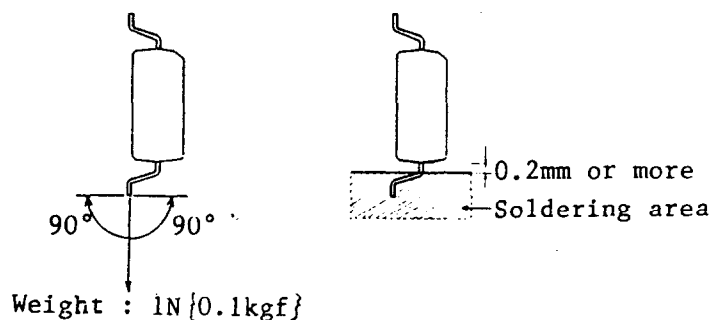

SHARP

5. Incoming inspection

5.1 Inspection items

(1) Electrical characteristics

 V_F , I_{CEO} , $V_{CE(sat)}$, I_c , R_{iso} , V_{iso}

(2) Appearance

5.2 Sampling method and Inspection level

A single sampling plan, normal inspection level II based on MIL-STD-105D is applied. The AQL according to the inspection items are shown below.

Defect	Inspection item	Inspection level	AQL(%)
Major defect	Electrical characteristics Unreadable marking	Normal inspection II	0.1
Minor defect	Appearance defect except the above mentioned.	Normal inspection II	0.4

SHARP

6.2 Package specifications

6.2.1 Taping conditions (Refer to the attached sheet, Page 10)

(1) Tape structure and Dimensions

The tape shall have a structure in which a cover tape is sealed heat-pressed on the carrier tape of hard vinylchloride to protect against static electricity.

(2) Reel structure and Dimensions (Refer to the attached sheet, Page 11)

The taping reel shall be of corrugated cardboard with its dimensions as shown in the attached drawing.

(3) Direction of product insertion (Refer to the attached sheet, Page 11)

Product direction in carrier tape shall direct to the anode mark at the hole side on the tape.

(4) Joint of tape

The cover tape and carrier tape in one reel shall be jointless.

(5) The way to repair taped failure devices

The way to repair taped failure devices cut a bottom of carrier tape with a cutter, and after replacing to good devices, the cutting portion shall be sealed with adhesive tape.

6.2.2 Adhesiveness of cover tape

The exfoliation force between carrier tape and cover tape shall be $0.2N\{20gf\} \sim 1N\{100gf\}$ for the angle from 160° to 180° .

6.2.3 Rolling method and quantity

Wind the tape back on the reel so that the cover tape will be outside the tape. Attach more than 20 cm of blank tape to the trailer and the leader of the tape and fix the both ends with adhesive tape.

One reel shall contain 1000 pcs.

6.2.4 Marking

The outer packaging case shall be marked with following information.

* Model No. * Number of pieces delivered * Production date

6.2.5 Storage condition

Taped products shall be stored at the temperature lower than $5 \sim 30^\circ C$ and the humidities lower than 70%RH.

6.2.6 Safety protection during shipping

There shall be no deformation of component or degradation of electrical characteristics due to shipping.

Tape structure and Dimensions

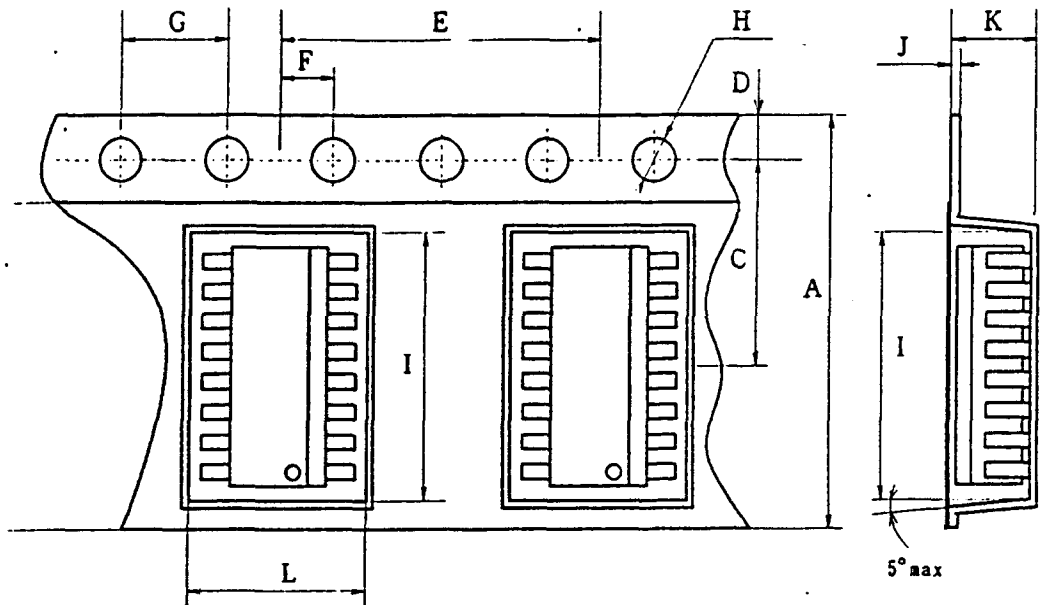

Dimension list (Unit : mm)

A	C	D	E	F	G	H	I
24.0±0.3	11.5±0.1	1.75±0.1	12.0±0.1	2.0±0.1	4.0±0.1	∅1.5 ^{±0.1}	10.8±0.1
J	K	L					
0.4±0.05	3.0±0.1	7.4±0.1					

Reel structure and Dimensions

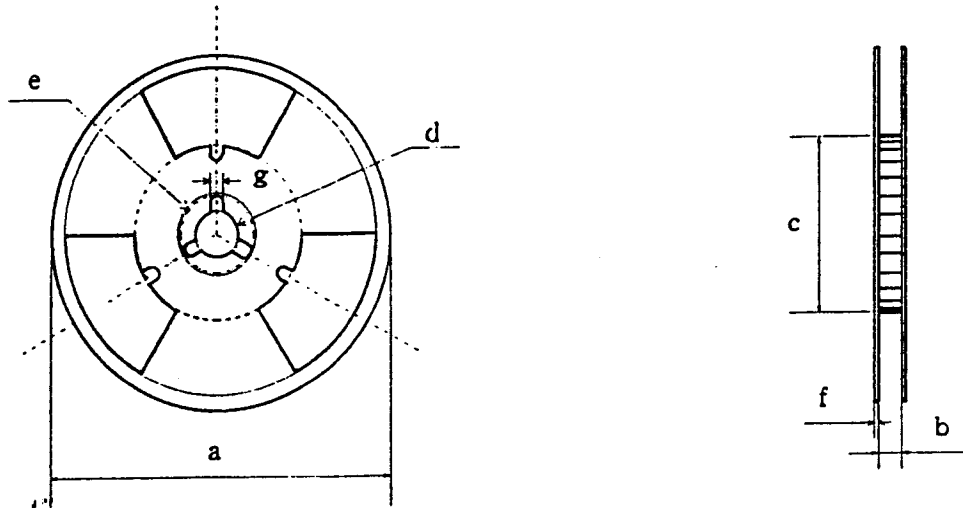

Dimension list (Unit : mm)

a	b	c	d	e	f	g
330	25.5±1.5	100±1.0	13±0.5	23±1.0	2.0±0.5	2.0±0.5

Direction of product insertion

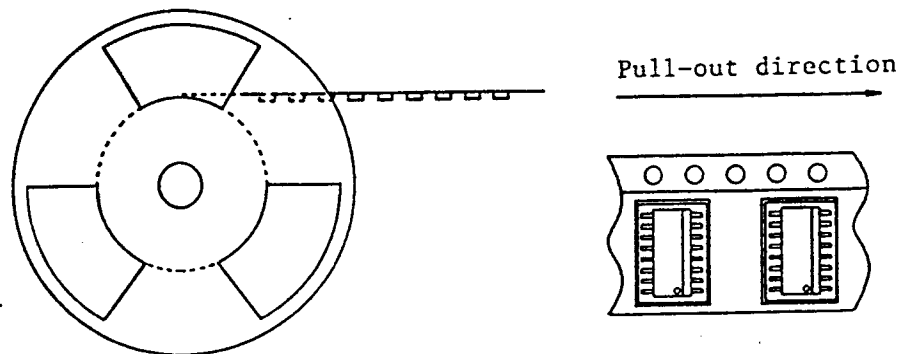

SHARP

Precautions for Soldering Photocouplers

1. If solder reflow:

It is recommended that only one soldering be done at the temperature and the time within the temperature profile as shown in the figure.

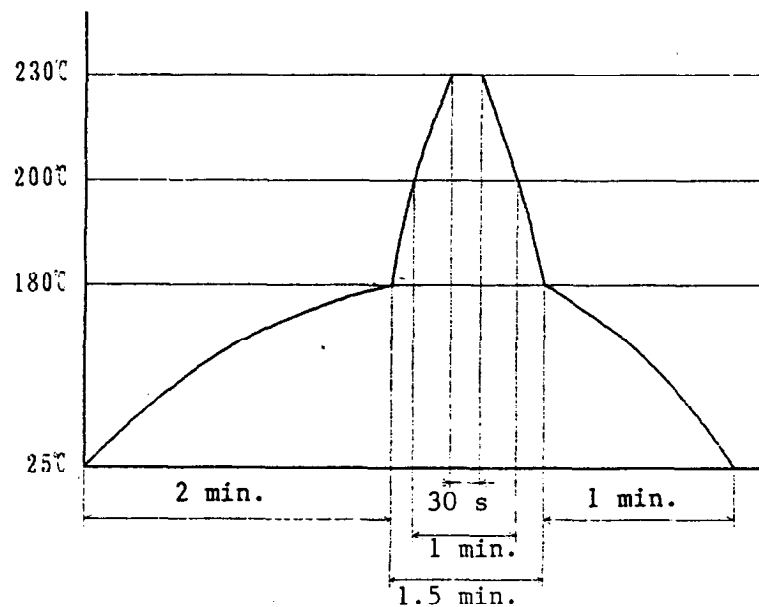



2. Other precautions



An infrared lamp used to heat up for soldering may cause a localized temperature rise in the resin. So keep the package temperature within that specified in Item 1. Also avoid immersing the resin part in the solder.

Looking for pricing, stock, or lifecycle information?

Click below to explore more details on WIN SOURCE:

-  [View PC3Q64 on WIN SOURCE](#)
-  [Sharp Microelectronics Information](#)

Optimize Your Supply Chain with WIN SOURCE Solutions

-  Global Sourcing Solution
-  Obsolete Management
-  Cost Control Management
-  Shortage Management
-  Alternative Solution
-  Excess Inventory Management