



**THE DATASHEET OF  
PC28F256P33TFA**





# **Conversion Guide: Numonyx™ StrataFlash® Embedded Memory P33 (256-Mbit, 256-Mbit/256- Mbit) 130nm to 65nm**

**Application Note - 909**

---

***Nov 2008***

INFORMATION IN THIS DOCUMENT IS PROVIDED IN CONNECTION WITH NUMONYX™ PRODUCTS. NO LICENSE, EXPRESS OR IMPLIED, BY ESTOPPEL OR OTHERWISE, TO ANY INTELLECTUAL PROPERTY RIGHTS IS GRANTED BY THIS DOCUMENT. EXCEPT AS PROVIDED IN NUMONYX'S TERMS AND CONDITIONS OF SALE FOR SUCH PRODUCTS, NUMONYX ASSUMES NO LIABILITY WHATSOEVER, AND NUMONYX DISCLAIMS ANY EXPRESS OR IMPLIED WARRANTY, RELATING TO SALE AND/OR USE OF NUMONYX PRODUCTS INCLUDING LIABILITY OR WARRANTIES RELATING TO FITNESS FOR A PARTICULAR PURPOSE, MERCHANTABILITY, OR INFRINGEMENT OF ANY PATENT, COPYRIGHT OR OTHER INTELLECTUAL PROPERTY RIGHT. Numonyx products are not intended for use in medical, life saving, life sustaining, critical control or safety systems, or in nuclear facility applications.

Numonyx B.V. may make changes to specifications and product descriptions at any time, without notice.

Numonyx B.V. may have patents or pending patent applications, trademarks, copyrights, or other intellectual property rights that relate to the presented subject matter. The furnishing of documents and other materials and information does not provide any license, express or implied, by estoppel or otherwise, to any such patents, trademarks, copyrights, or other intellectual property rights.

Designers must not rely on the absence or characteristics of any features or instructions marked "reserved" or "undefined." Numonyx reserves these for future definition and shall have no responsibility whatsoever for conflicts or incompatibilities arising from future changes to them.

Contact your local Numonyx sales office or your distributor to obtain the latest specifications and before placing your product order.

Copies of documents which have an order number and are referenced in this document, or other Numonyx literature may be obtained by visiting the Numonyx website at <http://www.numonyx.com>.

Numonyx, the Numonyx logo, and StrataFlash are trademarks or registered trademarks of Numonyx B.V. or its subsidiaries in other countries.

\*Other names and brands may be claimed as the property of others.

Copyright © 2008, Numonyx, B.V., All Rights Reserved.

## Contents

---

<b>1.0</b>	<b>Introduction</b> .....	5
<b>2.0</b>	<b>Device Overview</b> .....	5
2.1	P33 130nm Device .....	5
2.2	P33 65nm Device .....	5
2.3	P33 130nm and 65nm Features Comparison .....	6
<b>3.0</b>	<b>Device Packaging and Ballout</b> .....	7
3.1	Easy BGA Ballout .....	7
3.2	TSOP Pinout .....	8
<b>4.0</b>	<b>Hardware Design Considerations</b> .....	9
4.1	AC Read Specifications .....	9
4.2	AC Write/Erase Specifications .....	9
4.3	DC Current Specification .....	10
<b>5.0</b>	<b>Flash Software Design Considerations</b> .....	11
5.1	Device Identification .....	11
5.2	Read Configuration Register (RCR) .....	11
5.3	Blank Check .....	12
5.4	Device Commands .....	13
5.5	WAIT State Comparison .....	13
5.5.1	WAIT State P33 65nm .....	13
5.5.2	WAIT State P33 130nm .....	14
5.6	CFI Differences .....	15
5.6.1	CFI revision .....	15
5.6.2	Time-out changes .....	15
5.7	Performance Improvements in P33 65nm .....	16
<b>6.0</b>	<b>Conversion Considerations</b> .....	17
<b>A</b>	<b>Additional Information</b> .....	17

## Revision History

---

Date of Revision	Revision	Description
May 2008	001	Initial Release.
July 2008	02	Removed buffer programming difference; added in its place <a href="#">Section 5.7, "Performance Improvements in P33 65nm"</a> on page 16.
Sep 2008	03	Updated Axccl trademark Removed 64M related contents.
Nov 2008	04	Returned to StrataFlashl trademark Removed 128M related contents Clarify package options for each density Align Address to start from A1 Remove Numonyx Confidential Remove Enhanced Configuration Register command

## **1.0 Introduction**

This application note describes the migration from the Numonyx™ StrataFlash® Embedded Memory (P33-130nm) device to the Numonyx™ StrataFlash® Embedded Memory (P33-65nm) device.

*Note:* Unless otherwise indicated, throughout the rest of this document, the Numonyx™ StrataFlash® Embedded Memory (P33-130nm) device is referred to as the P33 130nm device and the Numonyx™ StrataFlash® Embedded Memory (P33-65nm) device is referred to as the P33 65nm device.

This document was written based on device information available at the time. Any changes in specifications to either device might not be reflected in this document. Refer to the appropriate documents or sales personnel for the current product information before finalizing any design.

## **2.0 Device Overview**

The following sections provide a brief overview of the feature differences between the P33 130nm and the P33 65nm devices.

### **2.1 P33 130nm Device**

The P33 130nm device features 64-Mbit through 512-Mbit densities and AC/DC specifications for 52MHz operation. Other features include high performance synchronous-burst read, Buffered Enhanced Factory Programming (BEFP) with a 32-word buffer, and an expanded OTP register space. Packaging options include industry-standard Easy BGA, TSOP and Quad+ packages.

### **2.2 P33 65nm Device**

The P33 65nm device features 64-Mbit through 2-Gbit densities and AC/DC specifications for 52 MHz operation. This document covers specially 256-Mbit and 512-Mbit (256M/256M) product information. Other features include high performance synchronous-burst read, Buffered Enhanced Factory Programming (BEFP) with a 512-word buffer, and an expanded OTP register space. The P33 65nm device also features enhanced protection via a password access feature, which allows users to protect write access to the pre-defined blocks. Please contact the Numonyx Sales for further details concerning password access. Packaging options include industry-standard Easy BGA and TSOP packages.

## 2.3 P33 130nm and 65nm Features Comparison

**Table 1: P33 130nm and 65nm Feature Comparison**

Features / Specifications		P33 130nm	P33 65nm
Available Densities (Monolithic)	64 Mbit	Yes	Yes*
	128 Mbit	Yes	Yes*
	256 Mbit	Yes	Yes
Available Densities (Stack)	512 Mbit	Yes	Yes
Performance	Speed	52 MHz	52 MHz
	Initial Access Time (Easy BGA)	85 ns	95 ns
	Initial Access Time (TSOP)	95 ns	105 ns
Block Architecture	Parameter Blocks	Four: 32-kByte	Four: 32-kByte
	Main Blocks	128-kByte	128-kByte
	16-bit data bus	Yes	Yes
Operating Voltage	Logic Core (V <sub>CC</sub> )	2.3 V to 3.6 V	2.3 V to 3.6 V
	I/O (V <sub>CCQ</sub> )	2.3 V to 3.6 V	2.3 V to 3.6 V
Features	OTP Register Space	128-bits + 2 Kbits	128-bits + 2 Kbits
	Flexible Block Locking	Yes	Yes
	Buffered Enhanced Factory Program	32-word buffer	512-word buffer
	Password Access	No	Yes
	Blank Check	No	Yes
Reliability	Operating Temperature	-40 °C to +85 °C	-40 °C to +85 °C
	Cycles	100,000	100,000

**Note:** This document doesn't cover 64-Mbit and 128-Mbit die information. Please refer to Numonyx local Sales for detail.

### 3.0 Device Packaging and Ballout

The following section provides a brief overview of the package and ballout differences between the P33 130nm and P33 65nm devices.

**Table 2: Package Comparison**

Features / Specifications		P33 130nm	P33 65nm
Monolithic Densities	Easy BGA	Yes	Yes
	TSOP	Yes	Yes
	QUAD+ (SCSP)	Yes	No
Stack Densities	Easy BGA	Yes	Yes
	TSOP	Yes	See Note
	QUAD+ (SCSP)	Yes	No

**Note:** For 256M/256M stack TSOP migration options, please contact your local Numonyx local Sales representative.

### 3.1 Easy BGA Ballout

The Easy BGA ballout is available for both P33 130nm and P33 65nm products. Ball pitch of the Easy BGA ballout is 1.0 mm. The package has an 8 x 8 active-ball matrix.

**Figure 1: 64-Ball Easy BGA Ballout (256/512-Mbit)**

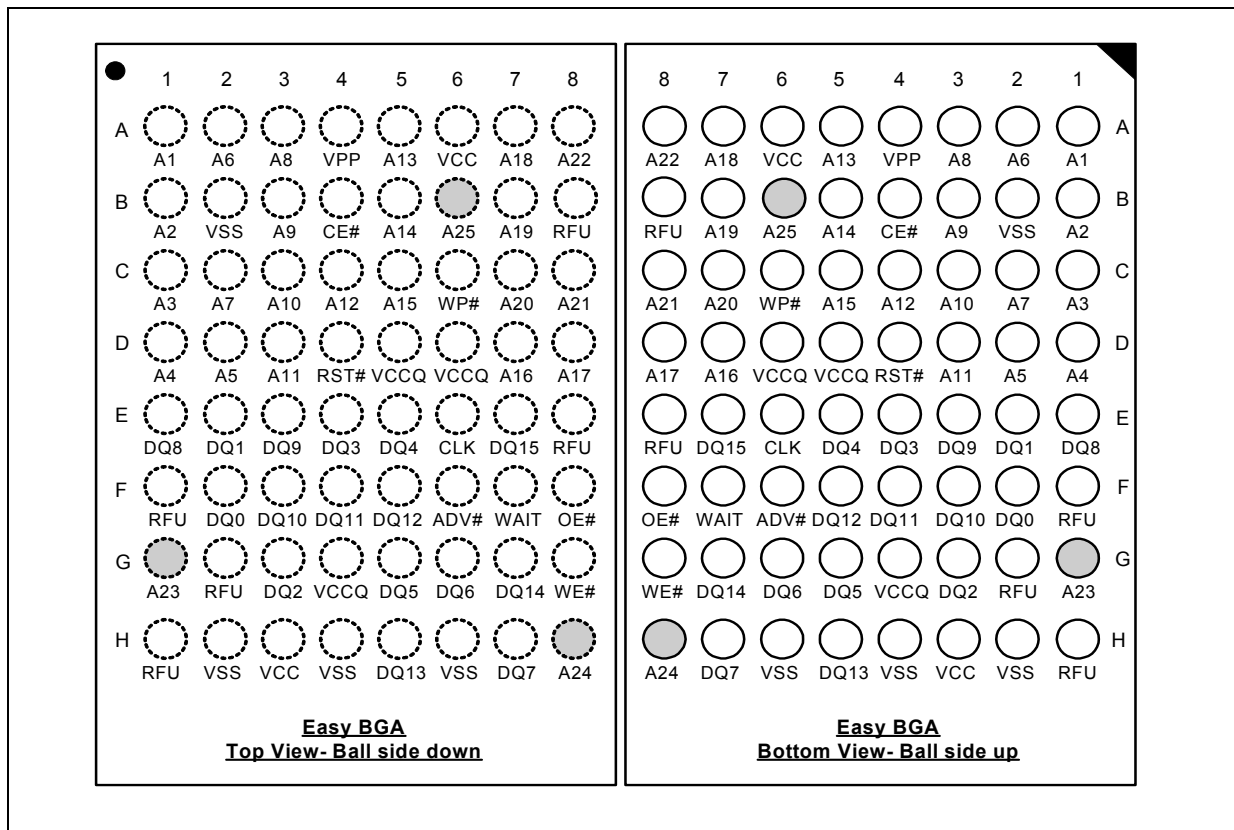

**Notes:**

1. A1 is the least significant address bit.
2. A24 is valid for 256-Mbit densities and above; otherwise, it is a no connect (NC).
3. A25 is valid for 512-Mbit densities; otherwise, it is a no connect (NC).

### 3.2 TSOP Pinout

The TSOP Pinout is available and compatible for both P33 130nm and P33 65nm products. Pin 13 on P33 130nm is connected to Vcc. For P33 65nm this pin has no internal connection; it may be driven or left floated

**Figure 2: 56-Lead TSOP Pinout (256-Mbit)**

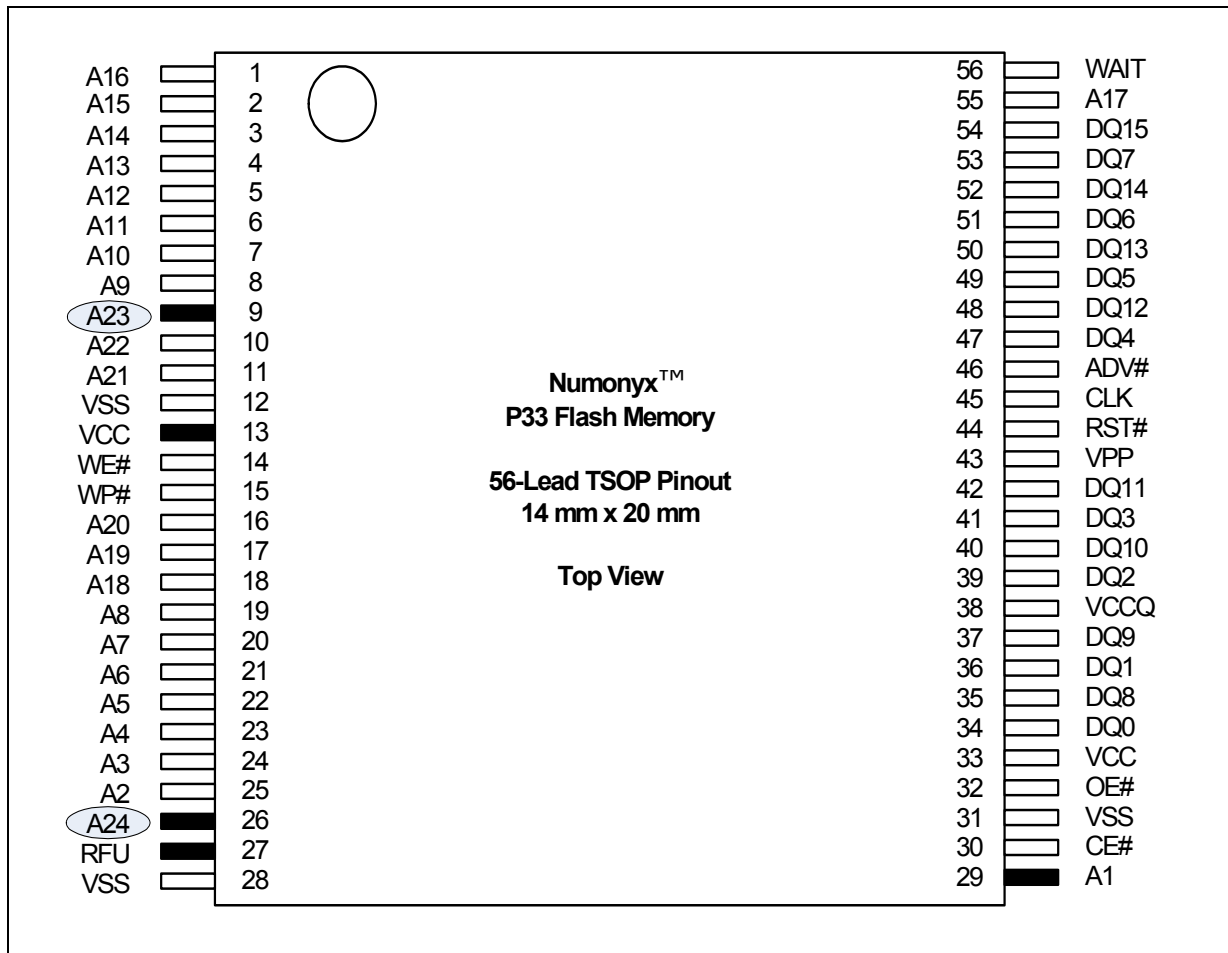

1. A1 is the least significant address bit.
2. A24 is valid for 256-Mbit densities; otherwise, it is a no connect (NC).
3. No Internal Connection on VCC Pin 13; it may be driven or floated. For legacy designs, pin can be tied to Vcc

## 4.0 Hardware Design Considerations

The P33 130nm and P33 65nm flash memory devices provide reliable, two-bit-per-cell storage technology for embedded applications. They satisfy the need for more density in less space, with a high-speed interface. Both flash devices feature asymmetrically-blocked architecture, Buffered Enhanced Factory Programming, and synchronous-burst read mode. The following sections discuss hardware design considerations when converting from the P33 130nm device to the P33 65nm device.

### 4.1 AC Read Specifications

Refer to the product datasheet for detailed list of all read timing specifications:

- Numonyx™ StrataFlash® Embedded Memory (P33-130nm) Datasheet (314749)
- Numonyx™ StrataFlash® Embedded Memory (P33-65nm) Datasheet (320003)

**Table 3: Key AC Read Specification Comparison**

Features / Specifications		P33 130nm	P33 65nm
Performance	Clock Frequency (Max)	52 MHz	52 MHz
	Asynchronous Access ( $t_{AVQV}$ $t_{VLQV}$ $t_{ELQV}$ )	Easy BGA: 85 ns	Easy BGA: 95 ns
		TSOP: 95 ns	TSOP: 105 ns
	Asynch Page Access time ( $t_{APA}$ )	25 ns	25 ns
	Clock-to-Data Burst Access ( $t_{CHQV}$ )	17 ns	17 ns
	Burst Data Hold Time ( $t_{CHQX}$ )	3 ns	3ns
	Address and ADV# Setup Time ( $t_{AVCH}$ , $t_{VLCH}$ )	9 ns	9 ns
	CE# Setup Time ( $t_{ELCH}$ )	9 ns	9 ns
	Rise/Fall Time ( $t_{FCLK/LCLK}$ )	3.0 ns	3.0 ns
	Clock High/Low Time ( $t_{CH/CL}$ )	5 ns	5ns
	Vcc power valid to RST# de-assertion (high)	60 us	300 us
	Async Page Size	4 words	16 words
	Synchronous Burst Length (word)	4-, 8-, 16-, and Cont.	4-, 8-, 16- and Cont.
	Burst Suspend Mode	Yes	Yes

### 4.2 AC Write/Erase Specifications

*Note:* Refer to the product datasheet for detailed list of all write and erase timing specifications.

- Numonyx™ StrataFlash® Embedded Memory (P33-130nm) Datasheet (314749)
- Numonyx™ StrataFlash® Embedded Memory (P33-65nm) Datasheet (320003)

**Table 4: Key AC Write-Erase Specification Comparison**

Features / Specifications		P33 130nm	P33 65nm
Program Performance	Program Buffer Size	64 Bytes	1024 Bytes
	Single Word Program Time (typ/max)	90/200 $\mu$ s	150/456 $\mu$ s
	Aligned 32-word Buffered Program Time (typ)	145 KBytes/s ( $V_{PPL}$ ) 188 KByte/s ( $V_{PPH}$ )	364 KBytes/s
	Aligned 64-word Buffered Program Time (typ)	—	593 KBytes/s
	Aligned 128-word Buffered Program Time (typ)	—	941 KBytes/s
	Aligned 256-word Buffered Program Time (typ)	—	1.29 MBytes/s
	Aligned 512-word Buffered Program Time (typ)	—	1.46 MBytes/s
	BEFP Environment Requirement	25 $^{\circ}$ C +/- 5 $^{\circ}$ C 100 P/E cycles	30 $^{\circ}$ C +/- 10 $^{\circ}$ C 50 P/E cycles
BEFP Time	188KB/s	2.0MB/s	
Erase Performance	Erase Time - 16KW Param. Block (typ/max)	0.4/2.5 s	0.8/4.0 s
	Erase Time - 64KW Main Block (typ/max)	0.8/4.0 s	0.8/4.0 s
	Program/Erase Suspend Latency (typ)	20 $\mu$ s	20 $\mu$ s
	Blank Check	No	Yes

### 4.3 DC Current Specification

The P33 65nm device consumes higher power than the P33 130nm device in standby mode under MAX condition.

**Table 5: Key DC Read Specification Comparison**

Features / Specifications		P33 130nm	P33 65nm
DC Current Characteristics	Standby Current (typ/max)	70/195 $\mu$ A (256-Mbit)	65/210 $\mu$ A (256-Mbit)
	Continuous Burst Read Current (max)	28 mA (52 MHz)	24 mA (52 MHz)
	Program/Erase Current (typ/max)	35/50 mA	35/50 mA
	VPP Factory Program Current (max)	22 mA	Less than 1 mA

## 5.0 Flash Software Design Considerations

The following sections discuss software design considerations when converting from the P33 130nm device to the P33 65nm device.

### 5.1 Device Identification

The P33 130nm and P33 65nm flash devices have identical device identification codes.

**Table 6: P33 Device ID Codes**

Code Type	Address Offset	Device Density	P33-130nm Codes		P33-65nm Codes	
			Top	Bottom	Top	Bottom
Device Identification	0x01	256 Mbit	891F	8922	891F	8922

### 5.2 Read Configuration Register (RCR)

Read configurations for both the P33 130nm and P33 65nm devices are configured using the Read Configuration Register (RCR). For example, to place the device in synchronous burst-read mode, you set the read mode bit in the RCR. The P33 65nm RCR includes the following modifications to the RCR:

- Latency Count *RCR[14:11]*: an additional bit, RCR14, has been added to the P33 65nm device; RCR14 was reserved on P33 130nm. P33 65nm supports latency counts of 8, 9, 10, 11, 12, 13, 14, and 15.
- WAIT Polarity *RCR[10]*: P33 130nm default setting high and P33 65nm default setting is low.
- Data Hold *RCR[9]*: P33 130nm supports 1-clock or 2-clock cycle data hold. RCR[9] is reserved for P33 65nm and supports a data hold of one cycle only.
- WAIT Delay *RCR[8]*: Same values for P33 130nm and P33-65nm.
- Burst Sequence *RCR[7]*: P33 130nm supports Linear "1" and Intel "0" burst order. P33 65nm supports linear "0" only. Setting P33 65nm to "1" will not affect the burst order; the burst order will always be linear.
- Clock Edge *RCR[6]*: Same values for P33 130nm and P33 65nm.
- Reserved *RCR[5:4]*: Same values for P33 130nm and P33 65nm.
- Burst Wrap *RCR[3]*: Same values for P33 130nm and P33 65nm.
- Burst Length *RCR[2:0]*: Same values for P33 130nm and P33 65nm.

*Note:* The differences are summarized in the table below.

**Table 7: Read Configuration Register Differences**

Register Field	Value	P33 130nm	P33 65nm
Latency Count	1000 = Code 8 1001 = Code 9 1010 = Code 10 1011 = Code 11 1100 = Code 12	NA	Available
WAIT Polarity	0 =WAIT signal is active low 1 =WAIT signal is active high	Default High	Default Low
Data Hold	0 =Data held for a 1-clock data cycle 1 =Data held for a 2-clock data cycle	Available	1-clock cycle only
Burst Sequence	0 =Reserved 1 =Linear	Intel Burst Order Linear Burst Order	Linear Burst Order
Clock Edge	0 = Falling edge 1 = Rising edge	Available	Available
Burst Wrap	0 =Wrap; Burst accesses wrap within burst length set by BL[2:0] 1 =No Wrap; Burst accesses do not wrap within burst length	Available	Available
Burst Length	001 =4-word burst 010 =8-word burst 011 =16-word burst 111 =Continuous-word burst	Available	Available

### 5.3 Blank Check

Blank Check is used to confirm whether a main-array block is completely erased. A Blank Check operation is performed one block at a time, and cannot be used during Program Suspend or Erase Suspend.

To use Blank Check, issue the Blank Check setup command then the confirm command. The addressed partition is automatically changed to Read Status Register mode, which remains in effect until another read-mode command is issued. During a blank check operation, the Status Register indicates a busy status (SR7 = 0). Upon completion, the Status Register indicates a ready status (SR7 = 1).

The Status Register should be checked for any errors, and then cleared. If the Blank Check operation fails, which means the block is not completely erased, the Status Register will indicate a Blank Check error (SR[7,5] = 1).

## 5.4 Device Commands

The command set for the P33 65nm and P33 130nm devices are fully compatible. However, the P33 65nm device includes new features such as the blank check operation and the enhanced configuration operation. Command set operations are compared here:

**Table 8: Command Bus Operations**

Command		P33 130nm Code (Setup/Confirm)	P33 65nm Code (Setup/Confirm)
Read Modes	Read Array	00FFh	00FFh
	Read Status Register	0070h	0070h
	Clear Status Register	0050h	0050h
	Read Device Information	0090h	0090h
	CFI Query	0098h	0098h
Program/Erase Operations	Word Program	0040h	0040h
	Buffered Program	00E8h/00D0h	00E8h/00D0h
	Buffered Enhanced Factory Program	0080h/00D0h	0080h/00D0h
	Block Erase	0020h/00D0h	0020h/00D0h
	Program/Erase Suspend	00B0h	00B0h
	Program/Erase Resume	00D0h	00D0h
	Blank Check	N/A	00BCh/00D0h
Security	Lock Block	0060h/0001h	0060h/0001h
	Unlock Block	0060h/00D0h	0060h/00D0h
	Lock Down Block	0060h/002Fh	0060h/002Fh
	Password Access	N/A	00EBh
Registers	Program Read Configuration Register	0060h/0003h	0060h/0003h
	Program OTP Register	00C0h	00C0h

**Note:** During Buffered Program command (E8h) sequence, if a read of the Main Array Data needs to be performed during the loading of the program buffer, then a write to an address outside of current block will abort the Buffer Programming Operation. Issuing the Read Array command (FFh) will put the device into Read Array mode. After Main Array read operation has been completed, the Buffer Program Operation must be restarted.

## 5.5 WAIT State Comparison

This section will compare the difference between the WAIT states on the P33 130nm and the P33 65nm.

### 5.5.1 WAIT State P33 65nm

End of wordline (EOWL) WAIT states can result when the starting address of the burst operation is not aligned to a 16-word boundary; that is, A[3:0] of start address does not equal 0x0. [Figure 3, "End of Wordline Timing Diagram" on page 14](#) illustrates the end of wordline WAIT state(s), which occur after the first 16-word boundary is reached. The number of data words and the number of WAIT states for both P33 130nm and P33 65nm are summarized in [Table 9, "End of Wordline Data and WAIT State Comparison" on page 14](#).

**Figure 3: End of Wordline Timing Diagram**

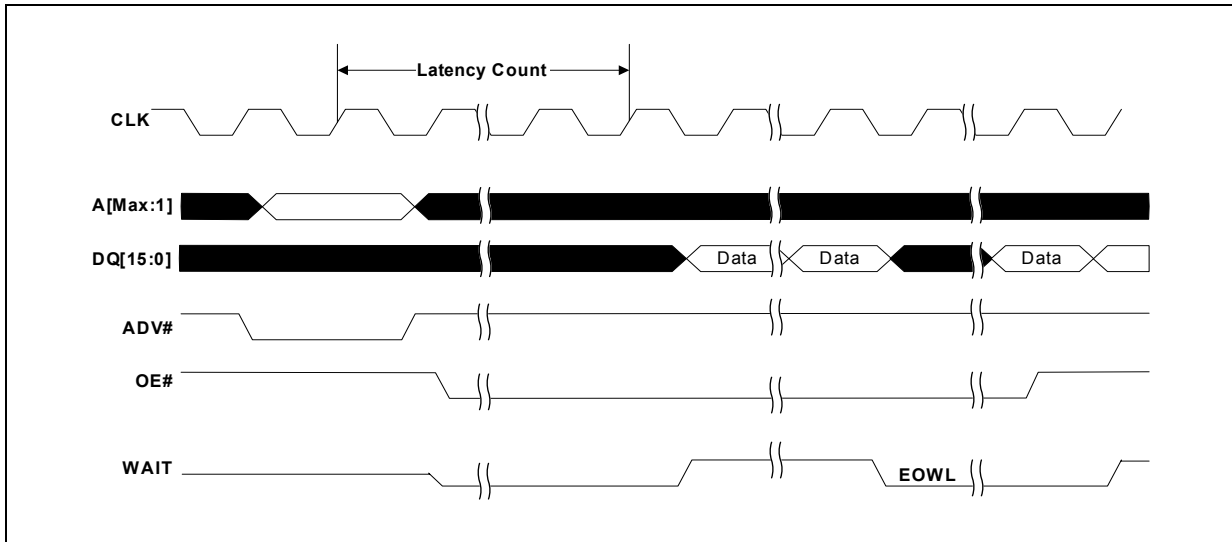

**Table 9: End of Wordline Data and WAIT State Comparison**

Latency Count	P33 130nm		P33 65nm	
	Data States	WAIT States	Data States	WAIT States
1	Not Supported	Not Supported	Not Supported	Not Supported
2	4	0 to 1	Not Supported	Not Supported
3	4	0 to 2	16	0 to 2
4	4	0 to 3	16	0 to 3
5	4	0 to 4	16	0 to 4
6	4	0 to 5	16	0 to 5
7	4	0 to 6	16	0 to 6
8	Not Supported	Not Supported	16	0 to 7
9			16	0 to 8
10			16	0 to 9
11			16	0 to 10
12			16	0 to 11
13			16	0 to 12
14			16	0 to 13
15			16	0 to 14

**5.5.2 WAIT State P33 130nm**

After encountering an EOWL situation, periodic WAIT states can occur in general as illustrated in Figure 4, "Periodic WAIT State Timing Diagram" on page 15.

Figure 10, "Periodic Data and WAIT State Comparison" on page 15 shows that P33 130nm has periodic WAIT states, but P33 65nm does not.

**Figure 4: Periodic WAIT State Timing Diagram**

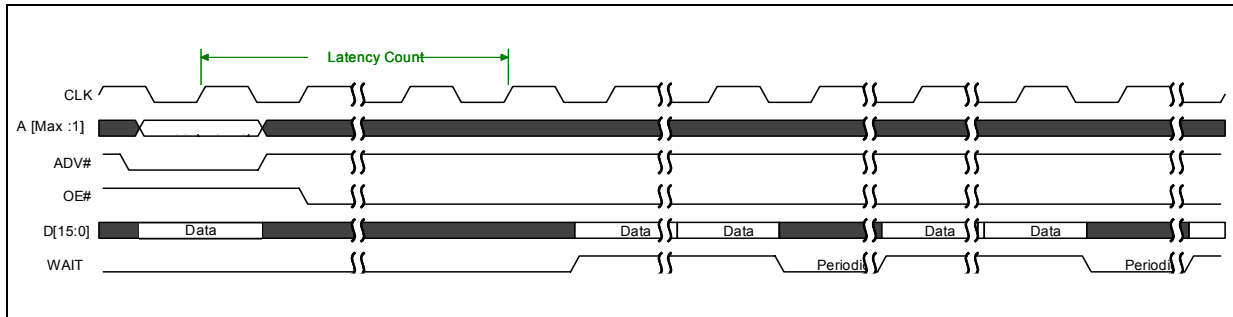

**Table 10: Periodic Data and WAIT State Comparison**

Latency Count	P33 130nm		P33 65nm	
	Data States	WAIT States	Data States	WAIT States
1	Not Supported	Not Supported	Not Supported	Not Supported
2	4	0	Not Supported	Not Supported
3	4	0	16	0
4	4	0	16	0
5	4	1	16	0
6	4	2	16	0
7	4	3	16	0
8	Not Supported	Not Supported	16	0
9			16	0
10			16	0
11			16	0
12			16	0
13			16	0
14			16	0
15			16	0

## 5.6 CFI Differences

P33 65nm has a different CFI revision. During adoption of Numonyx or third party software, several differences must be taken into account. This section will describe the changes.

### 5.6.1 CFI revision

The CFI minor revision sorted in offset (P+4)h remains as 5.

CFI version 1.5 is supported in the software provided by Numonyx.

### 5.6.2 Time-out changes

All CFI time-out changes are listed in [Table 11, "Value Changes"](#)

**Table 11: Value Changes**

Num	Difference	130nm		65nm	
		offset	value	offset	Values
1	"n" such that typical max. buffer write time-out = 2 <sup>n</sup> μ-sec	20h	512	20h	1024
2	"n" such that maximum buffer write time-out = 2 <sup>n</sup> times typical	24h	1024	24h	4096
3	"n" such that maximum number of bytes in write buffer = 2 <sup>n</sup>	2Ah	64	2Ah	1024
4	Page Mode Read capability bits 0–7 = "n" such that 2n HEX value represents the number of read-page bytes. See offset 28h for device word width to determine page-mode data output width. 00h indicates no read page buffer.	(P+1D)h	8	(P+1D)h	32

### 5.7 Performance Improvements in P33 65nm

The write performance can be increased on P33 65nm by using the 1024 Byte/512 Word buffer. If buffered programming is being done using the 16 word buffer (similar to 130nm devices), no software changes need to be implemented.

To achieve maximum performance using the 1024 Byte/ 512 Word buffer on 65nm devices, the following considerations apply during software modifications:

1. Use the Full 1024 Byte/ 512 Word Buffer
2. If 1024 Byte/ 512 Word Buffer is being used, the programming addresses should be aligned in 512 word address boundaries. For example: Start Programming address is 000000h and End Programming Address is 0001FFh. Please refer to Figure 3.
3. If the addresses must be mis-aligned, they must be in chunks of 256 Words. For example: Start Programming Address to Start Programming Address + 0000FFh (256 Words). Please refer to Figure 3.

The Read performance can be improved by providing read page buffer up to 16 Words (P+1Dh).

**Figure 5: Main Array Representation**

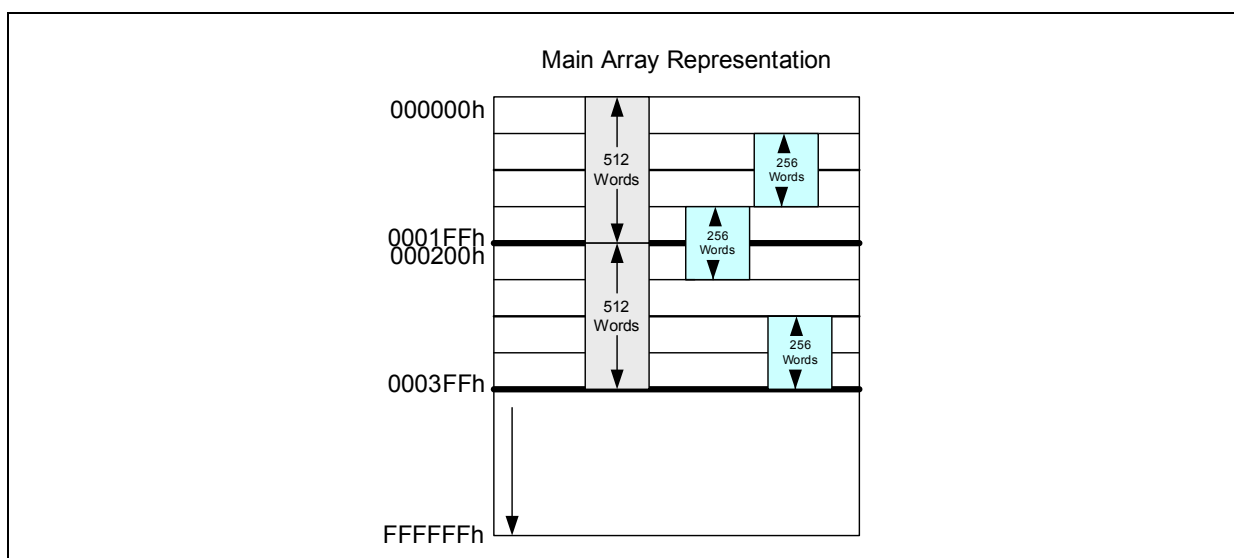

## **6.0 Conversion Considerations**

P33 65nm has a larger program buffer size to greatly improve the write performance. Users should use appropriate program and read modes to take advantage of this improved performance.

## **Appendix A Additional Information**



<b>Order/Document Number</b>	<b>Document/Tool</b>
314749	Numonyx™ StrataFlash® Embedded Memory (P33-130nm) Datasheet
320003	Numonyx™ StrataFlash® Embedded Memory (P33-65nm) Datasheet

**Note:** Contact your local Numonyx or distribution sales office or visit Numonyx's World Wide Web home page at <http://www.Numonyx.com> for technical documentation, tools, and additional information.



## Looking for pricing, stock, or lifecycle information?

Click below to explore more details on WIN SOURCE:

-  [View PC28F256P33TFA on WIN SOURCE](#)
-  [Micron Technology Inc. Information](#)

## Optimize Your Supply Chain with WIN SOURCE Solutions

-  Global Sourcing Solution
-  Obsolete Management
-  Cost Control Management
-  Shortage Management
-  Alternative Solution
-  Excess Inventory Management