



SPEC. No. ED-04P126A
ISSUE November 24, 2004

OPTO-ELECTRONIC DEVICES DIVISION
ELECTRONIC COMPONENTS GROUP
SHARP CORPORATION

SPECIFICATION

DEVICE SPECIFICATION FOR
PHOTOCOUPLER
MODEL No. PC123

Business dealing name

| | |
|--|--------------|
| | PC123Y12FZ0F |
| | PC123Y22FZ0F |
| | PC123Y52FZ0F |
| | PC123Y82FZ0F |
| | PC123Y92FZ0F |

Specified for

Enclosed please find copies of the Specifications which consists of 13 pages including cover.
This specification sheets and attached sheets shall be both side copy.
After confirmation of the contents, please be sure to send back copies of the Specifications
with approving signature on each.

CUSTOMER'S APPROVAL

DATE

BY

PRESENTED

DATE

BY



H. Imanaka,
Department General Manager of
Engineering Dept., II
Opto-Electronic Devices Div.
ELECOM Group
SHARP CORPORATION

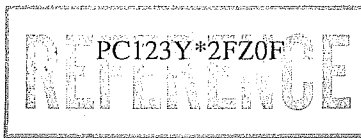

Product name : PHOTOCOUPLER

Model No. : PC123

Business dealing name

| |
|--------------|
| PC123Y12FZ0F |
| PC123Y22FZ0F |
| PC123Y52FZ0F |
| PC123Y82FZ0F |
| PC123Y92FZ0F |

1. These specification sheets include materials protected under copyright of Sharp Corporation ("Sharp"). Please do not reproduce or cause anyone to reproduce them without Sharp's consent.
2. When using this product, please observe the absolute maximum ratings and the instructions for use outlined in these specification sheets, as well as the precautions mentioned below. Sharp assumes no responsibility for any damage resulting from use of the product which does not comply with the absolute maximum ratings and the instructions included in these specification sheets, and the precautions mentioned below.

(Precautions)

- (1) This product is designed for use in the following application areas ;

- | | | |
|--|--------------------------|-------------------|
| · OA equipment | · Audio visual equipment | · Home appliances |
| · Telecommunication equipment (Terminal) | · Measuring equipment | |
| · Tooling machines | · Computers | |

If the use of the product in the above application areas is for equipment listed in paragraphs (2) or (3), please be sure to observe the precautions given in those respective paragraphs.

- (2) Appropriate measures, such as fail-safe design and redundant design considering the safety design of the overall system and equipment, should be taken to ensure reliability and safety when this product is used for equipment which demands high reliability and safety in function and precision, such as ;

- | | |
|--|---------------------------------|
| · Transportation control and safety equipment (aircraft, train, automobile etc.) | |
| · Traffic signals | · Gas leakage sensor breakers |
| · Other safety equipment | · Rescue and security equipment |

- (3) Please do not use this product for equipment which require extremely high reliability and safety in function and precision, such as ;

- | | |
|-----------------------------------|---|
| · Space equipment | · Telecommunication equipment (for trunk lines) |
| · Nuclear power control equipment | · Medical equipment etc. |

- (4) Please contact and consult with a Sharp sales representative if there are any questions regarding interpretation of the above three paragraphs.

3. Please contact and consult with a Sharp sales representative for any questions about this product.

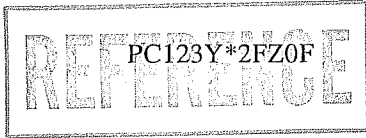

1. Application

This specification applies to the outline and characteristics of photocoupler Model No. PC123 (Lead-Free Type).

2. Outline Refer to the attached sheet, page 5.

3. Ratings and characteristics Refer to the attached sheet, page 6, 7.

4. Reliability Refer to the attached sheet, page 8.

5. Outgoing inspection Refer to the attached sheet, page 9.

6. Supplement

6.1 Isolation voltage shall be measured in the following method.

- (1) Short between anode and cathode on the primary side and between collector and emitter on the secondary side.
- (2) The dielectric withstanding tester with zero-cross circuit shall be used.
- (3) The wave form of applied voltage shall be a sine wave.

(It is recommended that the isolation voltage be measured in insulation oil.)

6.2 Packing specifications Refer to the attached sheet, page 10, 11.

6.3 Collector current (Ic) Delivery rank table ("O" mark indicates business dealing name of ordered product)

| Rank at delivery | * Business dealing name | Rank mark | Ic (mA) |
|------------------|-------------------------|-----------|--------------|
| | PC123Y12FZ0F | L | 2.5 to 7.5 |
| | PC123Y22FZ0F | M | 5.0 to 12.5 |
| | PC123Y52FZ0F | N | 10.0 to 20.0 |
| | PC123Y82FZ0F | E | 5.0 to 10.0 |
| | PC123Y92FZ0F | C | 8.0 to 15.0 |

| Test condition |
|---|
| I _F =5mA V _{CE} =5V Ta=25°C |

3. The relevant models are the models approved by VDE according to DIN EN60747-5-2 .

Up to date code "RD" (Decenber2003),the relevant models are approved by VDE according to DIN VDE0884/08.87.

Approved Model No. : PC123

VDE approved No. : 40008087 (According to the specification DIN EN60747-5-2)

- Operating isolation voltage U_{IORM} : 1140V (Peak)
- Transient voltage : 9000V (Peak)
- Pollution : 2
- Clearances distance (Between input and output) : 8.0mm (MIN.)
- Creep age distance (Between input and output) : 8.0mm (MIN.)
- Isolation thickness between input and output : 0.4mm (MIN.)
- Tracking-proof : CTI 175
- Safety limit values Current (I_{si}) : 200mA (Diode side)
- Power (P_{si}) : 300mW (Phototransistor side)
- Temperature (T_{si}) : 150°C

In order to keep safety electric isolation of photocoupler, please set the protective circuit to keep within safety limit values when the actual application equipment troubled.

• Indication of VDE approval "  " is printed on minimum unit package.

Isolation specification according to EN60747-5-2

| Parameter | Symbol | Condition | Rating | Unit | Remark |
|--|----------------------|----------------------|----------------------|------|---|
| Class of environmental test | - | - | 55/100/21 | - | |
| Pollution | - | - | 2 | - | |
| Maximum operating isolation voltage | U_{IORM} (PEAK) | - | 1140 | V | Refer to the Diagram 1, 2 (Page 4/11) |
| Partial discharge test voltage (Between input and output) | | | | | |
| Diagram 1 | U_{pr} | $t_p=10s, q_c<5pC$ | 1710 | V | |
| Diagram 2 | (PEAK) | $t_p=1s, q_c<5pC$ | 2140 | V | |
| Maximum over-voltage | U_{IOTM} (PEAK) | $t_{NI}=60s$ | 9000 | V | |
| Safety maximum ratings | | | | | Refer to the Fig. 1, 2 (Page 4/11) |
| 1) Case temperature | Tsi | $I_F=0, P_C=0$ | 150 | °C | |
| 2) Input current | Isi | $P_C=0$ | 200 | mA | |
| 3) Electric power (Output or Total power dissipation) | Psi | - | 300 | mW | |
| Isolation resistance (Test voltage between input and output ; DC500V) | R_{ISO} | $T_a=T_{si}$ | MIN.10 ⁹ | Ω | |
| | | $T_a=T_{opr}$ (MAX.) | MIN.10 ¹¹ | | |
| | | $T_a=25°C$ | MIN.10 ¹² | | |

Precautions in performing isolation test

- (1) Partial discharge test methods shall be the ones according to the specifications of EN60747-5-2
- (2) Please don't carry out isolation test (V_{iso}) over U_{IOTM} .
This product deteriorates isolation characteristics by partial discharge due to applying high voltage (ex. U_{IOTM}).
And there is possibility that this product occurs partial discharge in operating isolation voltage. (U_{IORM}).

6.5 This Model is approved by UL.

Approved Model No. : PC123
UL file No. : E64380

6.6 This Model is approved by CSA.

Approved Model No. : PC123
CSA file No. : CA95323

CSA approved mark "  " shall be indicated on minimum unit package.

6.7 This product is approved by BSI. (BS EN60065, BS EN60950)

Approved Model No. : PC123
Certificate No. : 7087/7409

6.8 This product is approved by SEMKO, DEMKO, NEMKO and FIMKO.

6.9 This product is not designed against irradiation.

This product is assembled with electrical input and output.
This product incorporates non-coherent light emitting diode.

6.10 ODS materials

This product shall not contain the following materials.

Also, the following materials shall not be used in the production process for this product.

Materials for ODS : CFC_s, Halon, Carbon tetrachloride, 1.1.1-Trichloroethane (Methyl chloroform)

6.11 Brominated flame retardants

Specific brominated flame retardants such as the PBBO_s and PBB_s are not used in this device at all.

7. Notes

Precautions for photocouplers : Attachment-1

Method of Diagram 1: Breakdown test (Apply to tape test and sampling test)

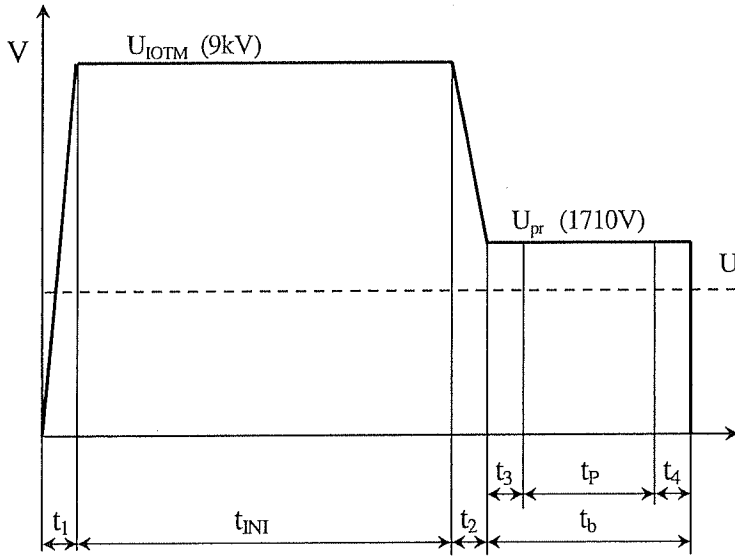

- t_1, t_2 = 1 to 10 s
- t_3, t_4 = 1 s
- t_P (Partial discharge measuring time) = 10 s
- t_b = 12 s
- t_{INI} = 60 s

Method of Diagram 2: Non breakdown test (Apply to all device test)

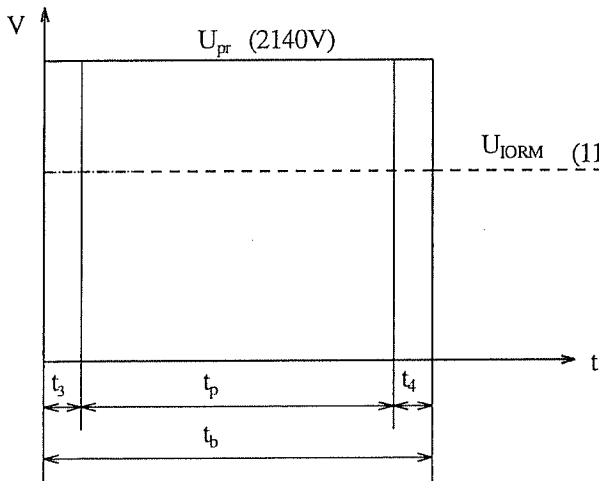

- t_3, t_4 = 0.1 s
- t_P (Partial discharge measuring time) = 1 s
- t_b = 1.2 s

(Fig.1) Safety maximum power dissipation vs. ambient temperature (When failed)

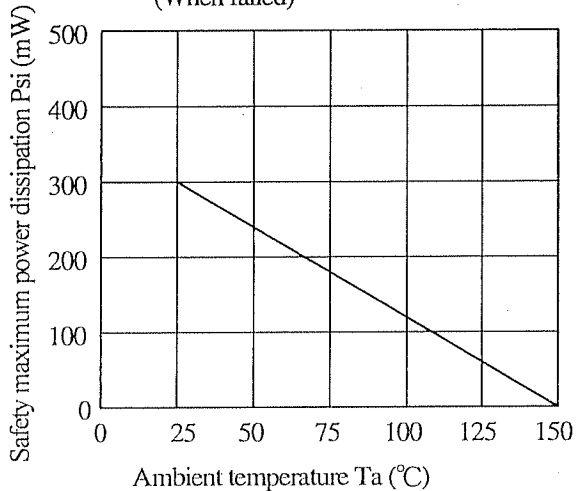

(Fig. 2) Safety maximum forward current vs. ambient temperature (When failed)

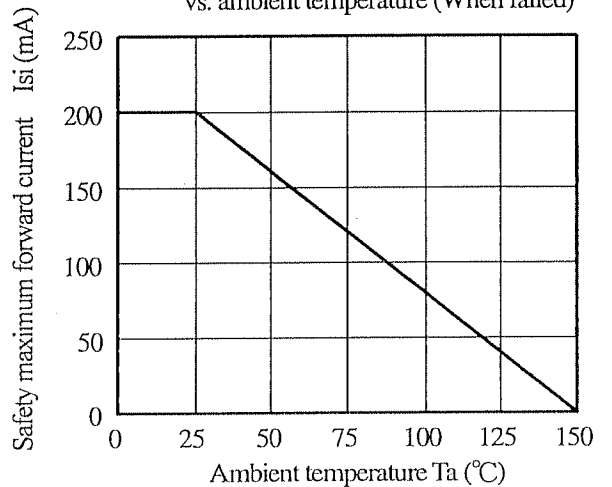

2. Outline

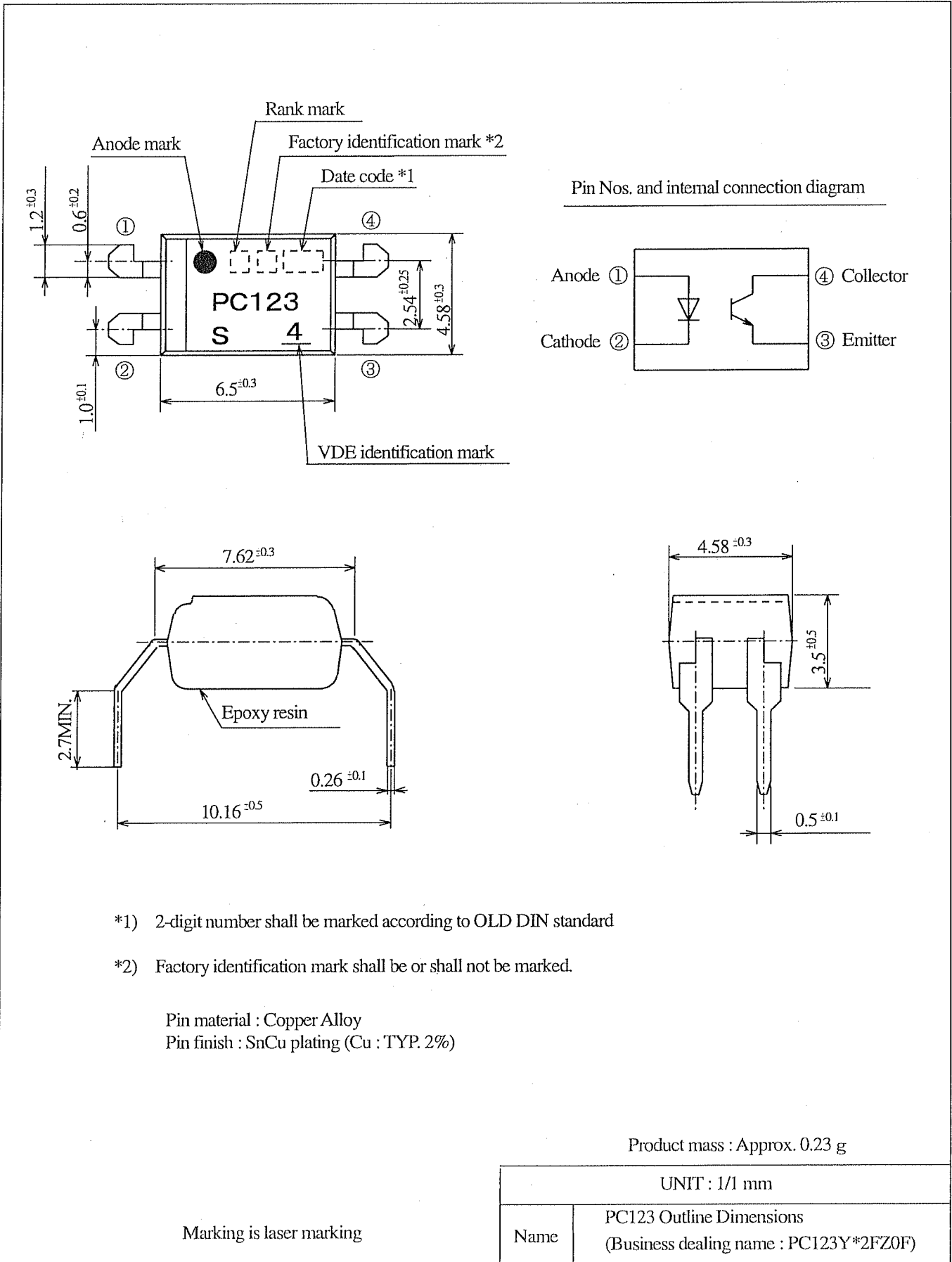

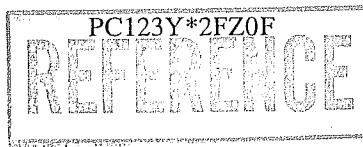

3. Ratings and characteristics

3.1 Absolute maximum ratings

Ta=25°C

| Parameter | | Symbol | Rating | Unit |
|----------------------------|--------------------------------|-----------------|-------------|------|
| Input | Forward current *1 | I_F | 50 | mA |
| | Peak forward current *2 | I_{FM} | 1 | A |
| | Reverse voltage | V_R | 6 | V |
| | Power dissipation *1 | P | 70 | mW |
| Output | Collector-emitter voltage | V_{CEO} | 70 | V |
| | Emitter-collector voltage | V_{ECO} | 6 | V |
| | Collector current | I_c | 50 | mA |
| | Collector power dissipation *1 | P_c | 150 | mW |
| Total power dissipation *1 | | P_{tot} | 200 | mW |
| Operating temperature | | T_{opr} | -30 to +100 | °C |
| Storage temperature | | T_{stg} | -55 to +125 | °C |
| Isolation voltage *3 | | $V_{iso (rms)}$ | 5 | kV |
| Soldering temperature *4 | | T_{sol} | 270 | °C |

3.2 Electro-optical characteristics

Ta=25°C

| Parameter | | Symbol | Condition | MIN. | TYP. | MAX. | Unit |
|--------------------------|--------------------------------------|---------------|--|--------------------|-----------|---------|----------|
| Input | Forward voltage | V_F | $I_F=20mA$ | - | 1.2 | 1.4 | V |
| | Reverse current | I_R | $V_R=4V$ | - | - | 10 | μA |
| | Terminal capacitance | C_t | $V=0, f=1kHz$ | - | 30 | 250 | pF |
| Output | Dark current | I_{CEO} | $V_{CE}=50V, I_F=0$ | - | - | 100 | nA |
| | Collector-emitter breakdown voltage | BV_{CEO} | $I_c=0.1mA, I_F=0$ | 70 | - | - | V |
| | Emitter-Collector breakdown voltage | BV_{ECO} | $I_c=10 \mu A, I_F=0$ | 6 | - | - | V |
| Transfer characteristics | Collector current | I_c | $I_F=5mA, V_{CE}=5V$ | 2.5 | - | 20 | mA |
| | Collector-emitter saturation voltage | $V_{CE(sat)}$ | $I_F=20mA, I_c=1mA$ | - | 0.1 | 0.2 | V |
| | Isolation resistance | R_{ISO} | DC500V 40 to 60%RH | 5×10^{10} | 10^{11} | - | Ω |
| | Floating capacitance | C_f | $V=0, f=1MHz$ | - | 0.6 | 1.0 | pF |
| | Cut-off frequency | f_c | $V_{CE}=5V, I_c=2mA$ $R_L=100 \Omega, -3dB$ | - | 80 | - | kHz |
| | Response time (Rise) | t_r | $V_{CE}=2V, I_c=2mA$ $R_L=100 \Omega$ | - | 4 | 18 | μs |
| Response time (Fall) | t_f | - | | 3 | 18 | μs | |

*1 The derating factors of absolute maximum ratings due to ambient temperature are shown in Fig. 1 to 4.

*2 Pulse width $\leq 100 \mu s$, Duty ratio : 0.001 (Refer to Fig. 5)

*3 AC for 1 min, 40 to 60%RH

*4 For 10s

(Fig.1) Forward current vs. ambient temperature

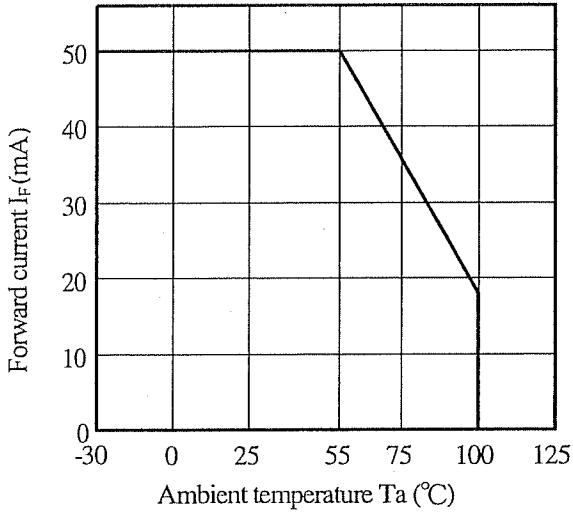

(Fig.2) Diode power dissipation vs. ambient temperature

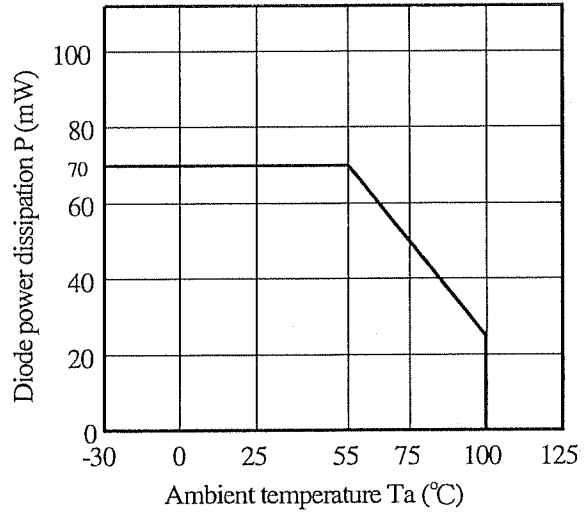

(Fig.3) Collector power dissipation vs. ambient temperature

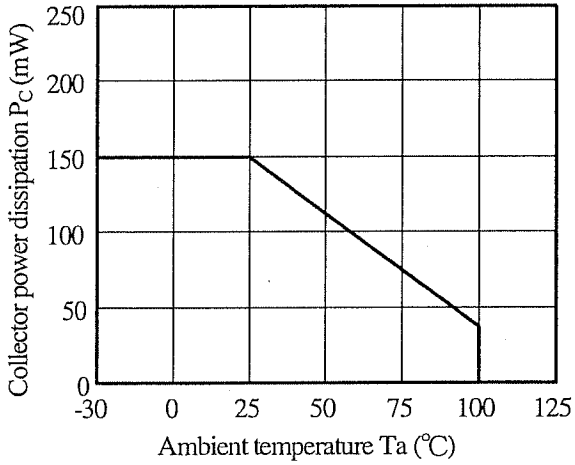

(Fig.4) Total power dissipation vs. ambient temperature

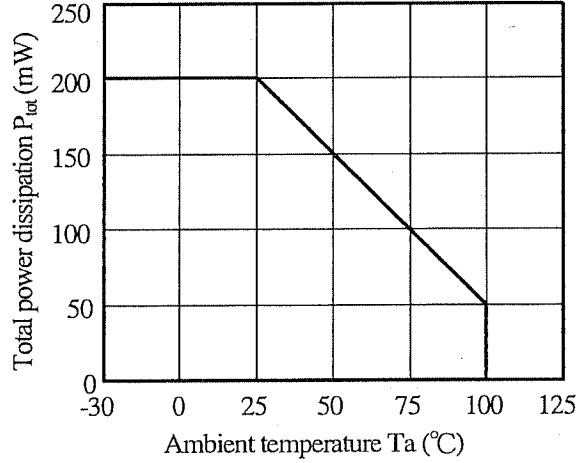

(Fig.5) Peak forward current vs. duty ratio
Pulse width $\leq 100\mu s$
 $T_a = 25^\circ C$

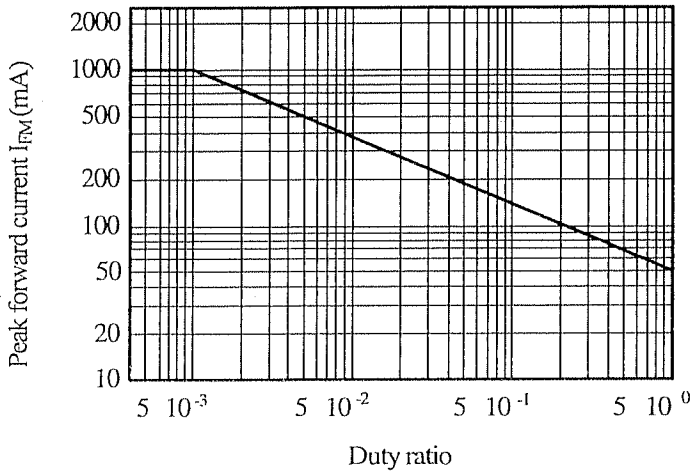

4. Reliability

The reliability of products shall satisfy items listed below.

Confidence level : 90%

LTPD : 10 or 20

| Test Items | Condition *1 | Failure Judgment Criteria | Samples (n) |
|--------------------------------------|---|--|---------------|
| | | | Defective (C) |
| Solder ability *2 | 245±3°C, 5s | - | n=11, C=0 |
| Soldering heat | (Flow soldering) 270°C, 10 s | $V_F > U \times 1.2$ $I_R > U \times 2$ $I_{CEO} > U \times 2$ $I_C < L \times 0.7$ $V_{CE(sat)} > U \times 1.2$ U: Upper specification limit L: Lower specification limit | n=11, C=0 |
| | (Soldering by hand) 400°C, 3 s | | n=11, C=0 |
| Terminal strength (Tension) | Weight: 5N 5s / each terminal | | n=11, C=0 |
| Terminal strength (Bending) *3 | Weight: 2.5N 2 times / each terminal | | n=11, C=0 |
| Mechanical shock | 15km/s ² , 0.5ms 3 times / ±X, ±Y, ±Z direction | | n=11, C=0 |
| Variable frequency vibration | 100 to 2000 to 100Hz / 4min, 200m/s ² 4 times / X, Y, Z direction | | n=11, C=0 |
| Temperature cycling | 1 cycle -55°C to +125°C (30 min) (30 min) 20 cycles test | | n=22, C=0 |
| High temp. and high Humidity storage | +85°C, 85%RH, 1000h | | n=22, C=0 |
| High temp. storage | +125°C, 1000h | | n=22, C=0 |
| Low temp. storage | -55°C, 1000h | | n=22, C=0 |
| Operation life | I _F =50mA, P _{tot} =200mW T _a =25°C, 1000h | n=22, C=0 | |

*1 Test method, conforms to EIAJ ED 4701.

*2 Solder shall adhere at the area of 95% or more of immersed portion of lead, and pin hole or other holes shall not be concentrated on one portion.

*3 Terminal bending direction is shown below.

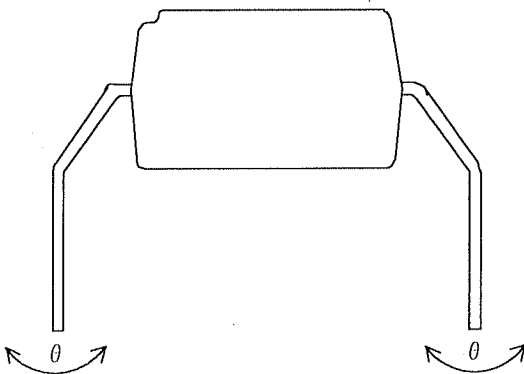

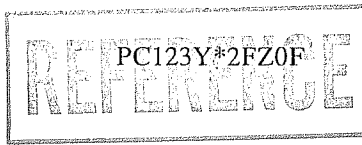

5. Outgoing inspection

5.1 Inspection items

(1) Electrical characteristics

$V_F, I_R, I_{CEO}, V_{CE(sat)}, I_C, R_{ISO}, V_{iso}$

(2) Appearance

5.2 Sampling method and Inspection level

A single sampling plan, normal inspection level II based on ISO 2859 is applied.

The AQL according to the inspection items are shown below.

| Defect | Inspection item | AQL (%) |
|--------------|--|---------|
| Major defect | Electrical characteristics Unreadable marking | 0.065 |
| Minor defect | Appearance defect except the above mentioned. | 0.25 |

6.2 Packing specification

6.2.1 Package materials

| No. | Name | Materials | Purposes |
|-----|--------------|---|--|
| ① | Sleeve | HIPS with preventing static electricity | Products packaged |
| ② | Stopper | Styrene-Erastomer | Products fixed |
| ③ | Packing case | Corrugated cardboard | Sleeve packaged |
| ④ | Molt plane | Urethane | Sleeve fixed |
| ⑤ | Kraft tape | Paper | Lid of packing case fixed |
| ⑥ | Label | Paper | Model No., quantity, inspection date and lot No. specified |

6.2.2 Package method

- (1) MAX. 100pcs. of products shall be packaged in a sleeve ① and both of sleeve edges shall be fixed by stoppers ②.
- (2) MAX. 20 sleeves (product : 2000pcs.) above shall be packaged in a packing case ③ and pack a sheet of Molt plane ④ at one side.
- (3) Model No., quantity, inspection date and lot No. shall be marked on the label ⑥ and this label shall be put on the side of the packing case.
- (4) Case shall be closed with the lid and enclosed with kraft tape ⑤.

6.2.3 Sleeve package ① outline dimensions

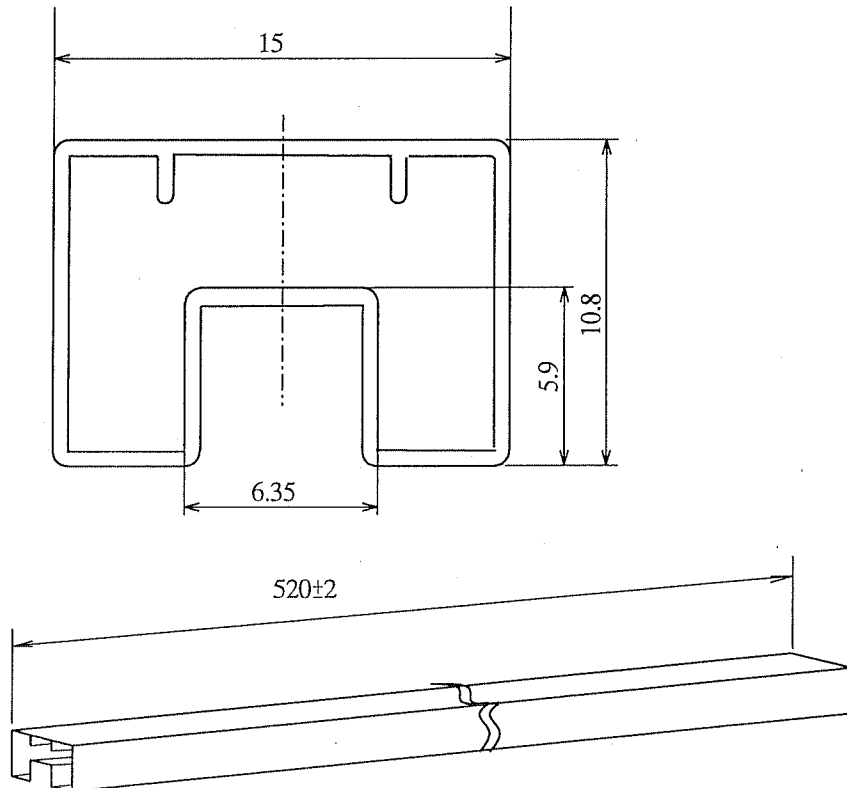

- Note
- 1) Thickness : 0.5 ± 0.2 mm
 - 2) Outer R : 0.5mm
 - 3) Process with applying antistatic agent.
 - 4) Unless otherwise specified tolerances shall be ± 0.5 mm.
(However except for deformation due to the stopper in sleeve.)

6.2.4 Packing case outline dimensions

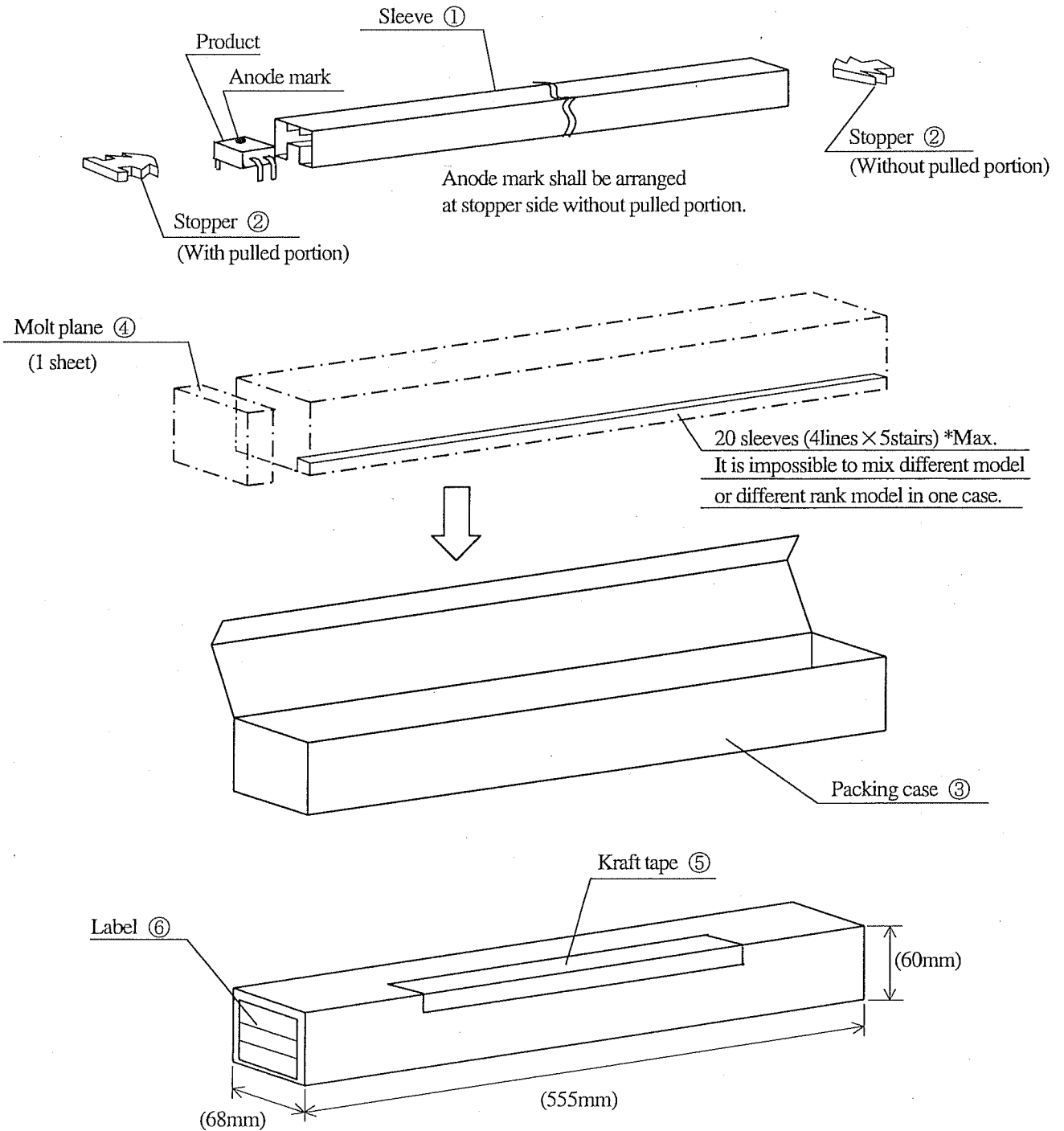

Regular packing mass : Approx. 860g
() : typical value

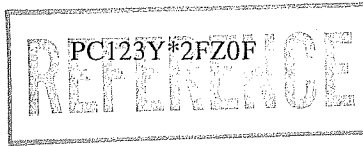

Precautions for Photocouplers

1 For cleaning

- (1) Solvent cleaning : Solvent temperature 45°C or less
Immersion for 3 min or less
- (2) Ultrasonic cleaning : The effect to device by ultrasonic cleaning differs by cleaning bath size, ultrasonic power output, cleaning time, PCB size or device mounting condition etc. Please test it in actual using condition and confirm that any defect doesn't occur before starting the ultrasonic cleaning.
- (3) Applicable solvent : Ethyl alcohol, Methyl alcohol, Isopropyl alcohol
When the other solvent is used, there are cases that the packaging resin is eroded.
Please use the other solvent after thorough confirmation is performed in actual using condition.

2. For circuit design

- 2.1 The LED used in the Photocoupler generally decreases the light emission power by operation.
In case of long operation time, please design the circuit in consideration of the degradation of the light emission power of the LED. (50%/5years)
- 2.2 There are cases that the deviation of the CTR and the degradation of the relative light emission power of the LED in consideration of the setting value of $I_F < 1\text{mA}$. Please design the circuit with considering this point.

3. Precautions for Soldering

- (1) In the case of flow soldering (Whole dipping is possible)
It is recommended that flow soldering should be at 270°C or less for 10 s or less
(Pre-heating : 100 to 150°C, 30 to 80s). (2 times or less)
- (2) In the case of hand soldering
What is done on the following condition is recommended.(2 times or less)
Soldering iron temperature : 400°C or less
Time : 3s or less
- (3) Other precautions
Depending on equipment and soldering conditions (temperature, Using solder etc.), the effect to the device PCB is different.
Please confirm that there is no problem on the actual use conditions in advance.

Looking for pricing, stock, or lifecycle information?

Click below to explore more details on WIN SOURCE:

- ⊖ [View PC123Y22FZ0F on WIN SOURCE](#)
- ⊖ [Sharp Microelectronics Information](#)

Optimize Your Supply Chain with WIN SOURCE Solutions

- ✓ Global Sourcing Solution
- ✓ Obsolete Management
- ✓ Cost Control Management
- ✓ Shortage Management
- ✓ Alternative Solution
- ✓ Excess Inventory Management