



**THE DATASHEET OF
PAM8615RHR**



16W/ 32W STEREO CLASS-D AUDIO POWER AMPLIFIER

Description

The PAM8615 is a 16W 32W (per channel) efficient Class-D audio power amplifier for driving stereo speakers in a single-ended configuration or mono bridge-tied speaker. The PAM8615 can drive single-ended speakers as low as 4Ω. Due to the low power dissipation and high efficiency the device can be used without any external heat sink when playing music.

Stereo speaker volume is controlled with a DC voltage applied to the volume control terminal offering a range of gain from -40dB to +36dB.

The PAM8615 is available in a TSSOP-24 package.

Features

- 32W/ch into 8Ω BTL Load from 24V Supply (Thermal Limited)
- 16W/ch into 4Ω SE Load from 24V Supply (Thermal Limited)
- Operates from 8V to 30V
- Supports Multiple Output Configurations:
 - 2-Ch Single-ended (half bridge)(16WX2)
 - 1 Ch Bridge-tied load (full bridge) (32WX1)
- High Efficiency Above 90%
- 64-Setup DC Volume Control from -40dB to +36dB
- Singel Ended Analog Inputs
- Thermal and Short-Circuit Protection
- Flexible Frequency Adjustable by External Component
- Clock Output for Synchronization with Multiple Class-D Devices
- No Pop Noise for Start-Up and Shut-Down Sequences
- Space-Saving Surface-Mount 24 Pin TSSOP Package
- Pb-Free Package

Pin Assignments

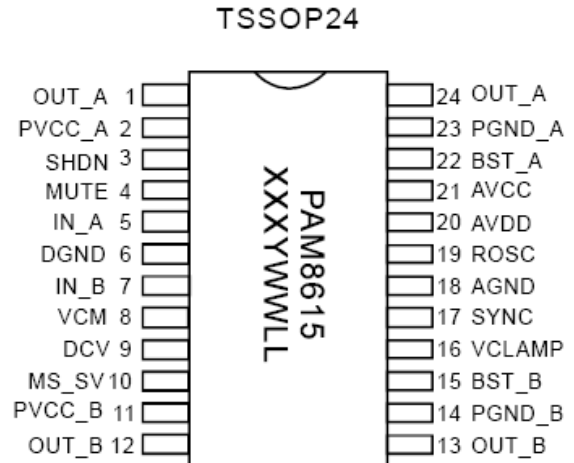

Applications

- Televisions
- Home Sound Systems

Typical Applications Circuit

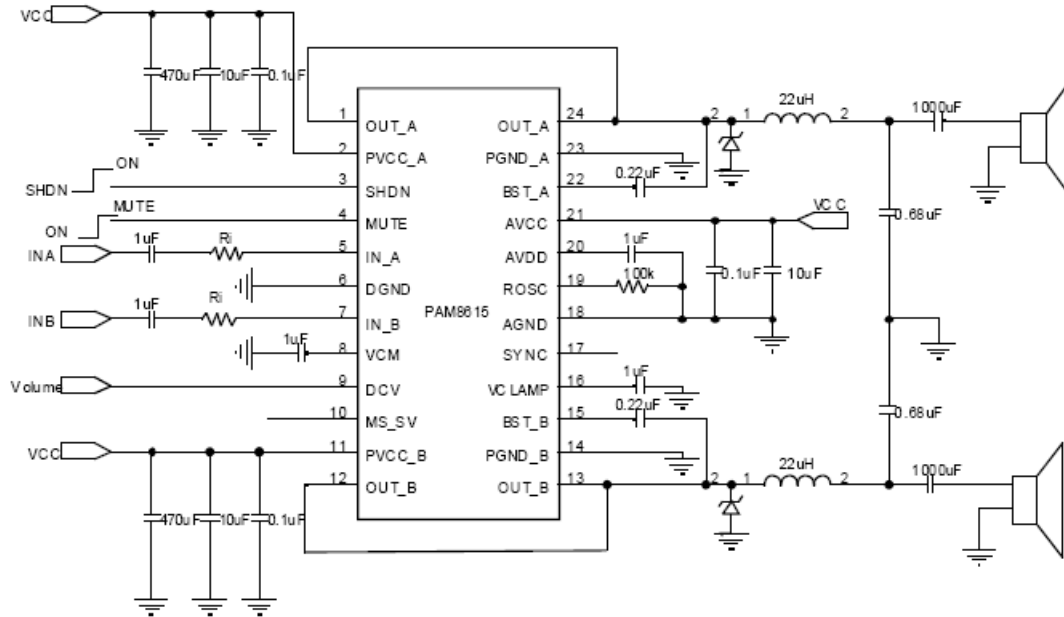

Single-Ended Configuration

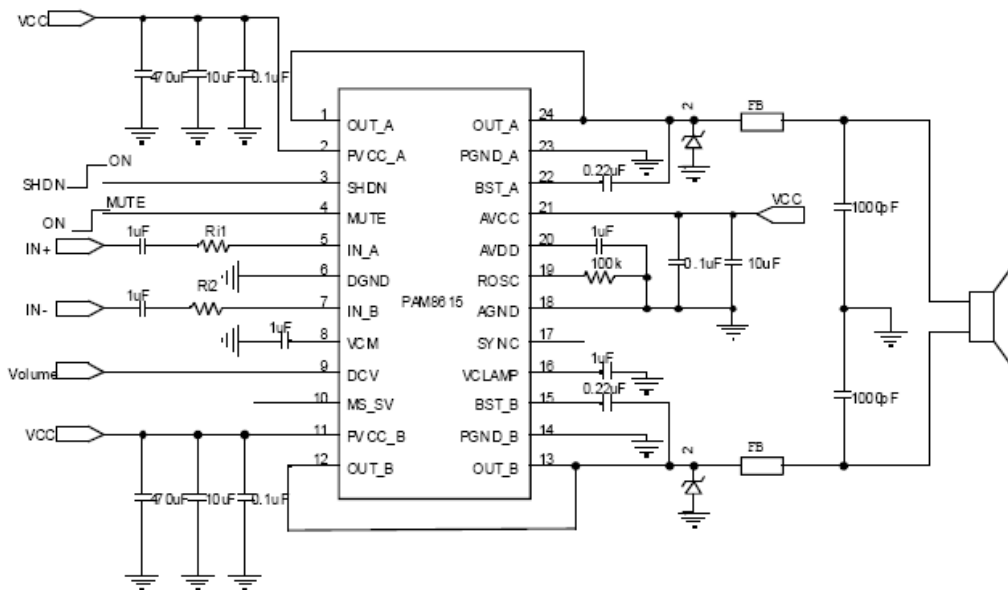

BTL Configuration

Pin Descriptions

Pin Number	Pin Name	I/O/P	Function
1	OUT_A	O	H-bridge A output.
2	PVCC_A	P	Power supply for H-bridge A not connected to PVCC_B or AVCC.
3	SHDN	I	Shutdown signal for IC (low = shutdown, high = operational). TTL logic levels with compliance to AVCC.
4	MUTE	I	Logic high on this pin disables the outputs. A low on this pin enables the outputs. TTL logic levels with compliance to AVCC.
5	IN_A	I	Audio input for channel A.
6	DGND	P	Digital GND
7	IN_B	I	Audio input for channel B.
8	VCM	O	Reference for analog cells.
9	DCV	I	DC voltage setting the gain of the amplifier.
10	MS_SV	I	Master/Slave select for determining direction of SYNC terminal. High = Master mode, SYNC terminal is an output; Low = Slave mode, SYNC terminal accepts a clock input.
11	PVCC_B	P	Power supply for H-bridge B, not connected to PVCC_A or AVCC
12, 13	OUT_B	O	H-bridge B output
14	PGND_B	P	Power ground for H-bridge B
15	BST_B	I/O	Bootstrap I/O for H-bridge B high-side FET
16	VCLAMP	P	Internally generated voltage supply for bootstrap. Not to be used as a supply or connected to any component other than the decoupling capacitor.
17	STNC	I/O	Clock input/output for synchronizing multiple class-D devices. Direction determined by MS_SV terminal.
18	AGND	P	Analog GND.
19	ROSC	I/O	Current setting resistor for ramp generator.
20	AVDD	P	Analog 5V Regulated output.
21	AVCC	P	High-voltage analog power supply.
22	BST_A	I/O	Bootstrap I/O for H-bridge A high-side FET.
23	PGND_A	P	Power ground for H-bridge A.

Functional Block Diagram

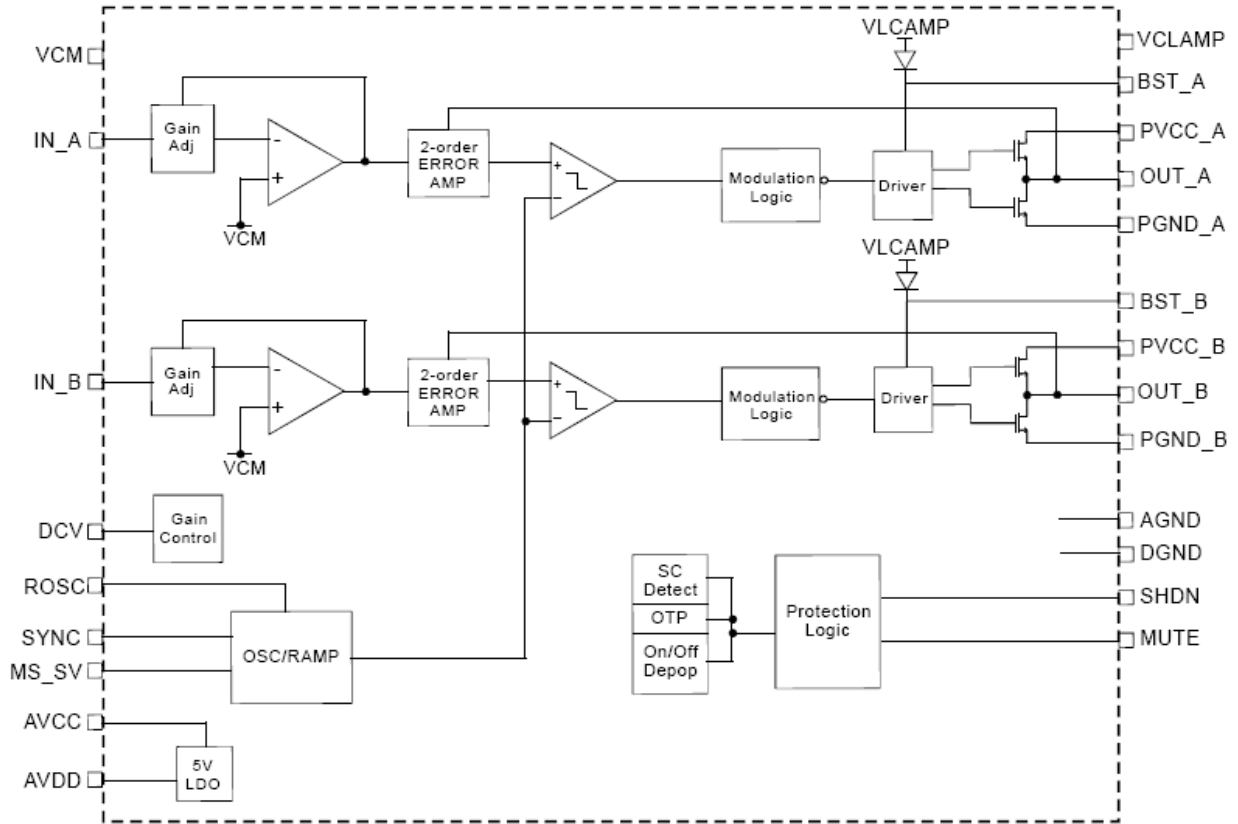

Absolute Maximum Ratings (@T_A = +25°C, unless otherwise specified.)

These are stress ratings only and functional operation is not implied. Exposure to absolute maximum ratings for prolonged time periods may affect device reliability. All voltages are with respect to ground.

Parameter	Rating	Unit
Supply Voltage AVCC, PVCC	-0.3 to +30	V
Logic Input Voltage:		
SHDN, MUTE	-0.3 to AVCC +0.3	V
DCV, MS_SV, SYNC	0 to +5.5	
Analog Input Voltage:		
IN-A, IN-B	0 to +5.5	V
Storage Temperature	-65 to +150	°C
Soldering Temperature	300, 5sec	

Recommended Operating Conditions (@T_A = +25°C, unless otherwise specified.)

Parameter	Rating	Unit
Supply Voltage (V _{CC})	10 to 26	V
DCV Volume Control Pin	0 to 5	
f _{OSC} Oscillator Frequency (R _{OSC} = 100kΩ)	250 to 350	kHz
T _A – Operating Free-Air Temperature	-40 to +85	°C
Ambient Operating Temperature	-20 to +85	
Ambient Temperature Range	-40 to +160	
Junction Temperature Range	-40 to +85	

Thermal Information

Parameter	Package	Symbol	Max	Unit
Thermal Resistance (Junction to Ambient)	TSSOP-24	θ _{JA}	30	°C/W

Electrical Characteristics (@T_A = +25°C, V_{CC} = 24V, Gain = 20dB, R_L = 4Ω, unless otherwise specified.)

Parameter	Symbol	Test Conditions	Min	Typ	Max	Units
Class-D Output Offset Voltage (measured differently)	V _{OS}	V _I = 0V, A _V = 36dB		10	65	mV
Quiescent Supply Current	I _{CC}	SHDN = 2V, MUTE = 0V, Input AC_GND, No load		25	40	mA
Quiescent Supply Current in Mute Mode	I _{CC(MUTE)}	MUTE = 2V, No load		25	40	mA
Quiescent Supply Current in Shutdown Mode	I _{CC(SD)}	SHDN = 0.5V, No load		5	20	μA
Oscillator Frequency	f _{OSC}	R _{OSC} = 100kΩ		323		kHz
Drain-Source On-State Resistance	R _{DS(ON)}	V _{CC} = 24V, I _O = 1A, T _A = 27°C		220		mΩ
Power Supply Rejection Ratio	PSRR	V _{CC} = 23.5V to 24.5V		-60		dB
Output Power at 1% THD+N	P _{O(SE)}	V _{CC} = 24V, R _L = 4Ω, f = 1kHz		14		W
		V _{CC} = 24V, R _L = 8Ω, f = 1kHz		8.2		
Output Power at 10% THD+N	P _{O(SE)}	V _{CC} = 24V, R _L = 4Ω, f = 1kHz		17.3		W
		V _{CC} = 24V, R _L = 8Ω, f = 1kHz		9.8		
Output Power at 1% THD+N	P _{O(BTL)}	V _{CC} = 24V, R _L = 8Ω, f = 1kHz		27		W
		V _{CC} = 12V, R _L = 8Ω, f = 1kHz		7		
Output Power at 10% THD+N		V _{CC} = 24V, R _L = 8Ω, f = 1kHz		35		
		V _{CC} = 12V, R _L = 8Ω, f = 1kHz		9		
Total Harmonic Distortion + Noise	THD+N	R _L = 4Ω, f = 1kHz, P _O = 10W		0.25%		
		R _L = 8Ω, f = 1kHz, P _O = 5W		0.15%		
Output Integrated Noise Floor	V _N	20Hz to 22kHz, A-weighted filter, Gain = 20dB		-67		dBV
Crosstalk	C _S	P _O = 1W, f = 1kHz, Gain = 20dB		-60		dB
Signal-to-Noise Ratio	SNR	Max output at THD+N < 1%, f = 1kHz, Gain = 20dB		86		dB
Thermal Trip Point				160		°C
Thermal Hysteresis				40		°C

DC Volume Control

STEP	VOLTAGE OF THE VOLUME	TOTAL_GAIN	STEP	VOLTAGE OF THE VOLUME	TOTAL_GAIN
	(V)	(dB)		(V)	(dB)
1	0.10	-60	33	2.34	17.4
2	0.17	-40	34	2.41	18.0
3	0.24	-30	35	2.48	18.6
4	0.31	-20	36	2.55	19.2
5	0.38	-10	37	2.62	19.8
6	0.45	-5	38	2.69	20.4
7	0.52	-2.5	39	2.76	21.0
8	0.59	0	40	2.83	21.6
9	0.66	2	41	2.90	22.2
10	0.73	3	42	2.97	22.8
11	0.80	4	43	3.04	23.4
12	0.87	4.8	44	3.11	24.0
13	0.94	5.4	45	3.18	24.6
14	1.01	6.0	46	3.25	25.2
15	1.08	6.6	47	3.32	25.8
16	1.15	7.2	48	3.39	26.4
17	1.22	7.8	49	3.46	27.0
18	1.29	8.4	50	3.53	27.6
19	1.36	9.0	51	3.60	28.2
20	1.43	9.6	52	3.67	28.8
21	1.50	10.2	53	3.74	29.4
22	1.57	10.8	54	3.81	30.0
23	1.64	11.4	55	3.88	30.6
24	1.71	12.0	56	3.95	31.2
25	1.78	12.6	57	4.02	31.8
26	1.85	13.2	58	4.09	32.4
27	1.92	13.8	59	4.16	33.0
28	1.99	14.4	60	4.23	33.6
29	2.06	15.0	61	4.30	34.2
30	2.13	15.6	62	4.37	34.8
31	2.20	16.2	63	4.44	35.4
32	2.27	16.8	64	4.51	36.0

Typical Performance Characteristics (@ $T_A = +25^\circ\text{C}$, $V_{DD} = 24\text{V}$, $R_L = 8\Omega$, unless otherwise specified.)

1. THD Power — Single-Ended (Load=8Ω)

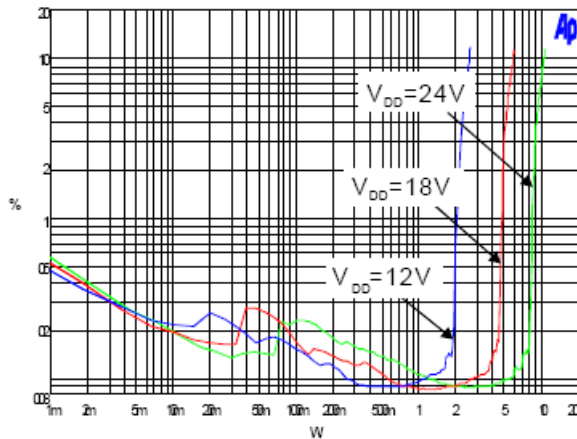

2. THD Power — Single-Ended (load=4Ω)

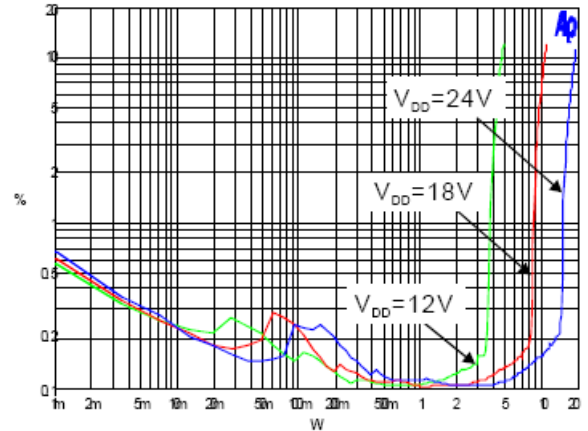

3. Frequency response — Single-Ended

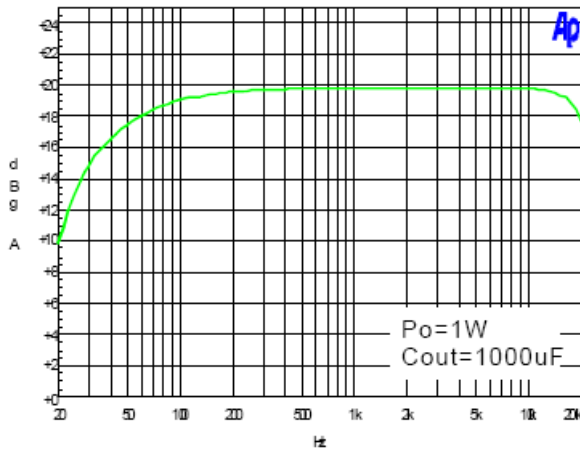

4. Cross talk — Single-Ended

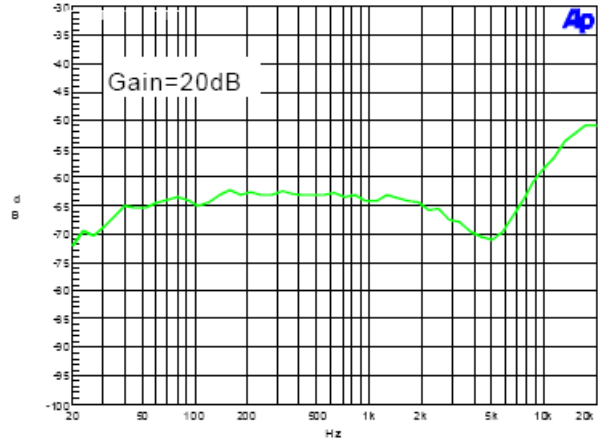

5. PSRR — Single-Ended

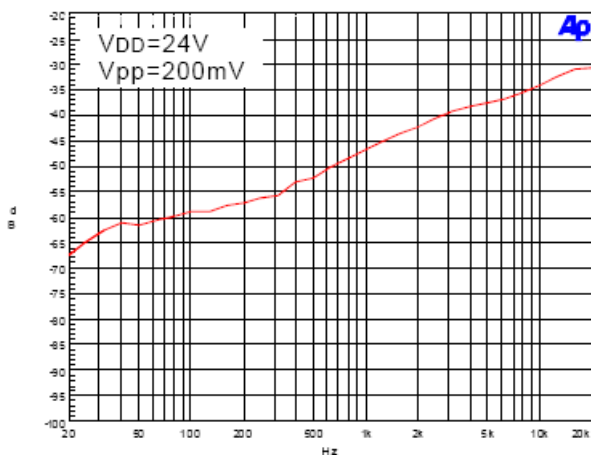

6. THD Power — Single-Ended

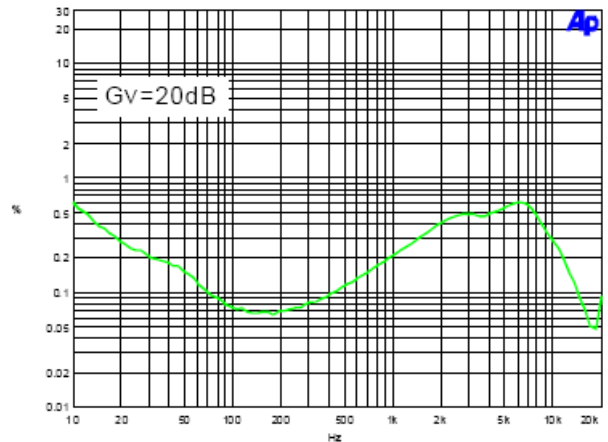

Typical Performance Characteristics (cont.) (@ $T_A = +25^\circ\text{C}$, $V_{DD} = 24\text{V}$, $R_L = 8\Omega$, unless otherwise specified.)

7. THD Power—BTL

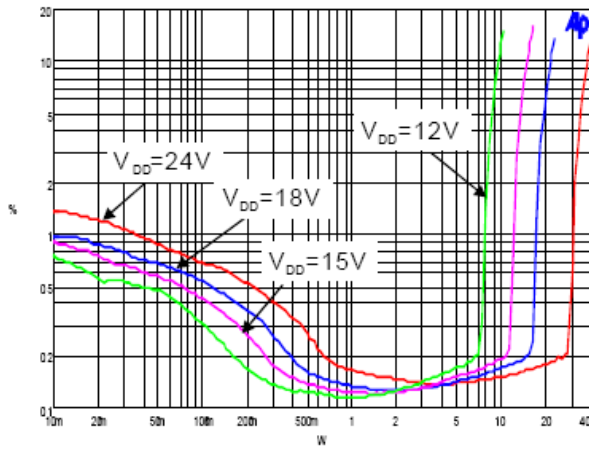

8. Frequency response—BTL

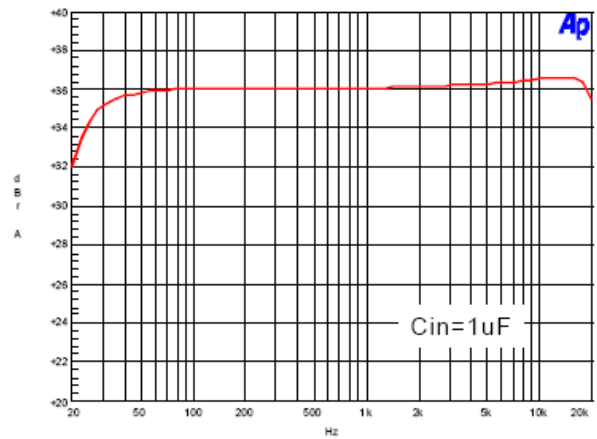

9. THD Frequency—BTL

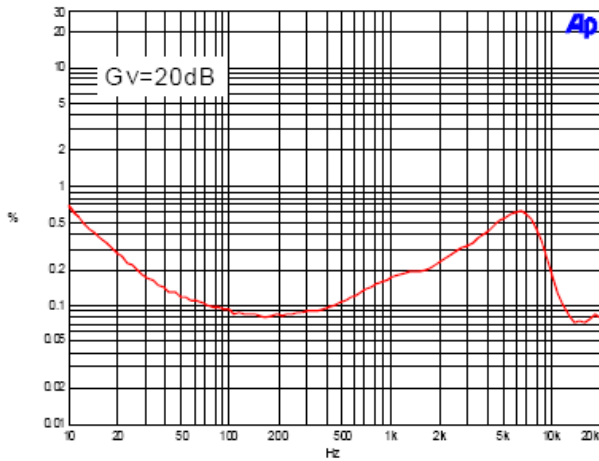

10. PSRR—BTL

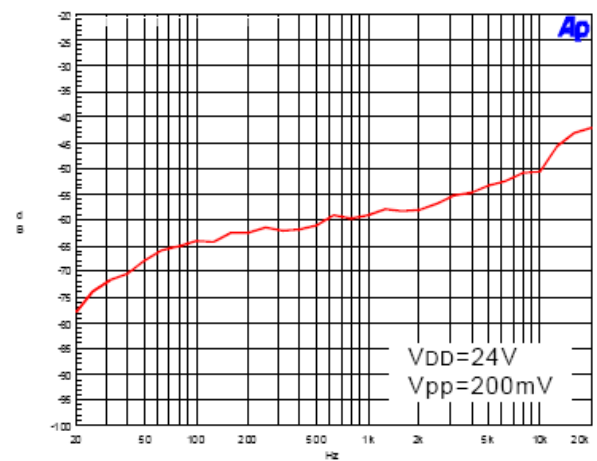

Test Setup for Performance Testing

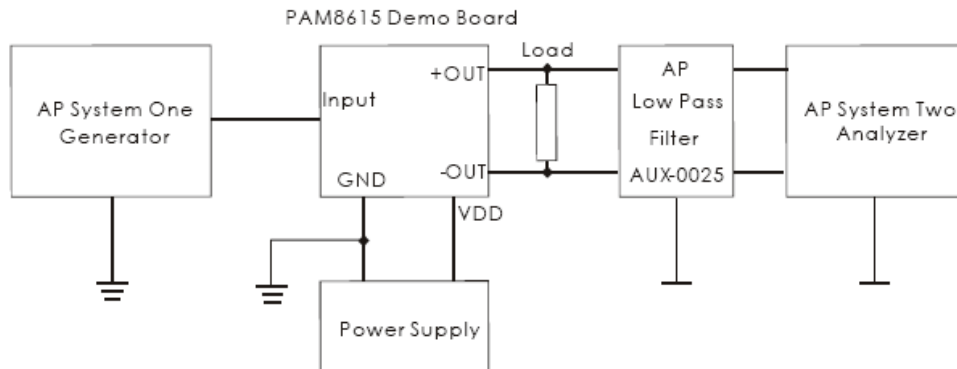

- Notes:
1. The AP AUX-0025 low pass filter is necessary for class-D amplifier measurement with AP analyzer.
 2. Two 22 μ H inductors are used in series with load resistor to emulate the small speaker for efficiency measurement.

Application Information

Power and Heat Dissipation

Choose speakers that are able to stand large output power from the PAM8615. Otherwise, speaker may suffer damage.

Heat dissipation is very important when the device works in full power operation. Two factors affect the heat dissipation, the efficiency of the device that determines the dissipation power, and the thermal resistance of the package that determines the heat dissipation capability.

Generally, Class-D amplifiers are high efficiency and need no heat sink. For high power ones that has high dissipation power, the heat sink may also not necessary if the PCB is carefully designed to achieve good heat dissipation by the PCB itself.

Dual-Side PCB

To achieve good heat dissipation, the PCB's copper plate should be thicker than 35 μ m and the copper plate on both sides of the PCB should be utilized for heat sink.

The thermal pad on the bottom of the device should be soldered to the plate of the PCB, and via holes, usually 9 to 16 should be drilled in the PCB area under the device and deposited copper on the vias should be thick enough so that the heat can be dissipated to the other side of the plate. There should be no insulation mask on the other side of the copper plate. It is better to drill more vias on the PCB around the device if possible.

Volume Control

A DC volume control section is integrated in PAM8615, controlling via DCV and DGND terminals. The voltage on DCV pin, determines internal amplifier gain as listed in Page 6.

If a resistor divider is used to fix gain of the amplifier, the DCV terminal can be directly connected to the resistor divider connected across AVDD and DGND. For fixed gain, the resistor divider values are calculated to center the voltage given in Page 6.

MUTE Operation

The MUTE pin is an input for controlling the output state of the PAM8615. A logic high on this pin disables the outputs and low enables the outputs. This pin may be used as a quick disable or enable of the outputs without a volume fade.

Application Information (cont.)

Shutdown Operation

The PAM8615 employs a shutdown operation mode to reduce supply current to the absolute minimum level during periods of non-use to save power. The SD input terminal should be pull high during normal operation when the amplifier is in use. Pulling SD low causes the outputs to mute and the amplifier to enter a low-current state. SD should never be left unconnected to prevent the amplifier from unpredictable operation.

For the best power-off pop performance, the amplifier should be set in shutdown mode prior to removing the power supply voltage.

Internal Bias Generator Capacitor Selection

The internal bias generator (VCM) provides the internal bias for the preamplifier stage. The external input capacitors and this internal reference allow the inputs to be biased within the optimal common-mode range of the input preamplifiers.

The selection of the capacitor value on the VCM terminal is critical for achieving the best device performance. During startup or recovery from shutdown state, the VCM capacitor determines the rate at which the amplifier starts up. The startup time is not critical for the best de-pop performance since any heard pop sound is the result of the class-D output switching-on other than that of the startup time. However, at least a 0.47µF capacitor is recommended for the VCM capacitor.

Another function of the VCM capacitor is to bypass high frequency noise on the internal bias generator.

Power Supply Decoupling, CS

The PAM8615 is a high-performance CMOS audio amplifier that requires adequate power supply decoupling to ensure the output total harmonic distortion (THD) as low as possible. Power supply decoupling also prevents oscillations caused by long lead between the amplifier and the speaker. The optimum decoupling is achieved by using two capacitors of different types that target different types of noise on the power supply leads. For higher frequency transients, spikes, or digital hash on the line, a good low equivalent-series-resistance (ESR) ceramic capacitor, typically 0.1µF, is recommended, placing as close as possible to the device's PVCC lead. To filter lower-frequency noises, a large aluminum electrolytic capacitor of 470µF or greater is recommended, placing near the audio power amplifier. The 10µF capacitor also serves as a local storage capacitor for supplying current during large signal transients on the amplifier outputs.

Selection of ROSC

The switching frequency is determined by the values of components connected to ROSC (pin 19) and calculated with the following equation:

$$f_{\text{OSC}} = \frac{0.68}{R_{\text{OSC}} \times 21\text{pF}}$$

The recommended values is $R_{\text{OSC}} = 100\text{k}\Omega$ for a switching frequency of 323kHz.

BST_A and BST_B Capacitors

The half H-bridge output stages use NMOS transistors only. They therefore require bootstrap capacitors for the high side of each output to turn on correctly. An at least 220nF ceramic capacitor, rated for at least 25V, must be connected from each output to its corresponding bootstrap input. Specifically, one 220nF capacitor must be connected from OUT_A to BST_A, and another 220nF capacitor from OUT_B to BST_B. It is recommended to use 1µF BST capacitor to replace 220nF for lower than 100Hz applications.

VCLAMP Capacitors

To ensure that the maximum gate-to-source voltage for the NMOS output transistors not exceeded, two internal regulators are used to clamp the gate voltage. A 1µF capacitors must be connected from VCLAMP to ground and must be rated for at least 25V. The voltages at the VCLAMP terminals vary with VCC and may not be used to power any other circuitry.

Internal Regulated 5-V Supply (AVDD)

The AVDD terminal is the output of an internally generated 5V supply, used for the oscillator, preamplifier, and volume control circuitry. It requires a 0.1µF to 1µF capacitor, placed very close to the pin to Ground to keep the regulator stable. The regulator may not be used to power any external circuitry.

Application Information (cont.)

Using low-ESR Capacitors

Low - ESR capacitors are recommended throughout this application section. A real (with respect to ideal) capacitor can be modeled simply as a resistor in series with an ideal capacitor. The voltage drop across this resistor minimizes the beneficial effects of the capacitor in the circuit. The lower the equivalent value of this resistance the more the real capacitor behaves as an ideal capacitor.

Short-Circuit Protection

The PAM8615 has short circuit protection circuitry on the outputs to prevent damage to the device when output-to-output shorts (BTL mode), output-to- GND shorts, or output-to-VCC shorts occur. Once a short-circuit is detected on the outputs, the output drive is immediately disabled. This is a latched fault and must be reset by cycling the voltage on the SD pin to a logic low and back to the logic high state for normal operation. This will clear the short-circuit flag and allow for normal operation if the short was removed. If the short was not removed, the protection circuitry will again activate.

Thermal Protection

Thermal protection on the PAM8615 prevents damage to the device when the internal die temperature exceeds +160°C. There is a ±15 degree tolerance on this trip point from device to device. Once the die temperature exceeds the set thermal point, the device enters into the shutdown state and the outputs are disabled. This is not a latched fault. The thermal fault is cleared once the temperature of the die is reduced by +40°C. The device begins normal operation at this point without external system intervention.

Master-Slave and SYNC Operation

The MS/SL and SYNC terminals can be used to synchronize the frequency of the class-D output switching. When the MS/SL is high or left floating due to the internal pull up resistor, the switching frequency is determined by the ROSC. The SYNC becomes an output whose source/sink current is about 0.5mA, and the frequency of this output is also determined by the ROSC. And this output can be connected to another PAM8615 who is configured in the slave mode. The output switching is synchronized to avoid any beat frequencies that occur in the audio band when two Class-D amplifiers in the same system are switching at the slight different frequencies. When the MS/SL is low, the switching frequency is determined by the incoming square wave on the SYNC input. The SYNC becomes an input in this mode and accept a square wave from another PAM8615 configured in the master mode or from an external GPIO.

(Key: MS/SL = "H", Master Mode, MS/SL = "L", Slave Mode)

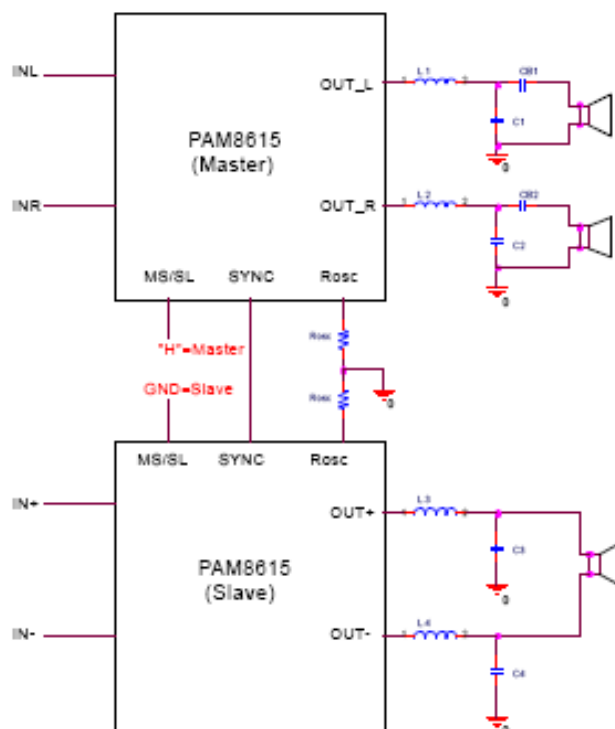

Ordering Information

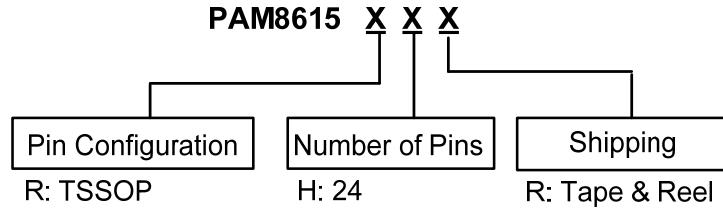

Part Number	Package Type	Standard Package
PAM8615RHR	TSSOP-24	3000 Units/Tape & Reel

Marking Information

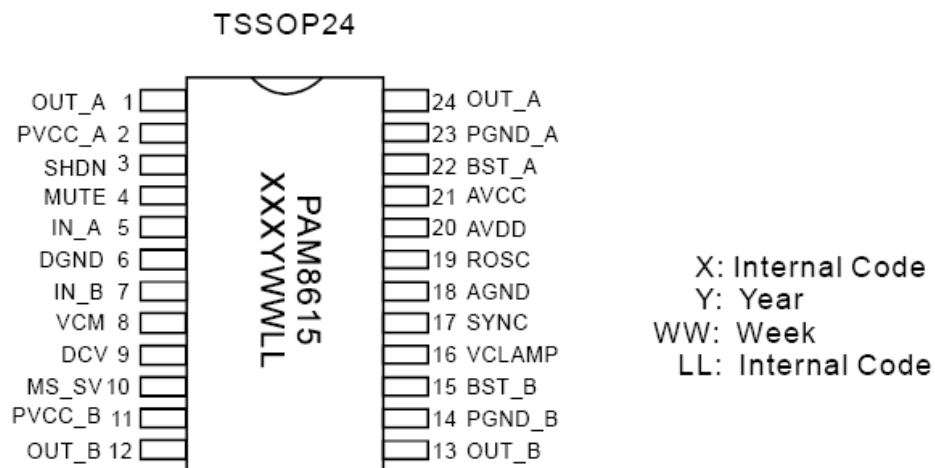

Package Outline Dimensions (All dimensions in mm.)

TSSOP-24

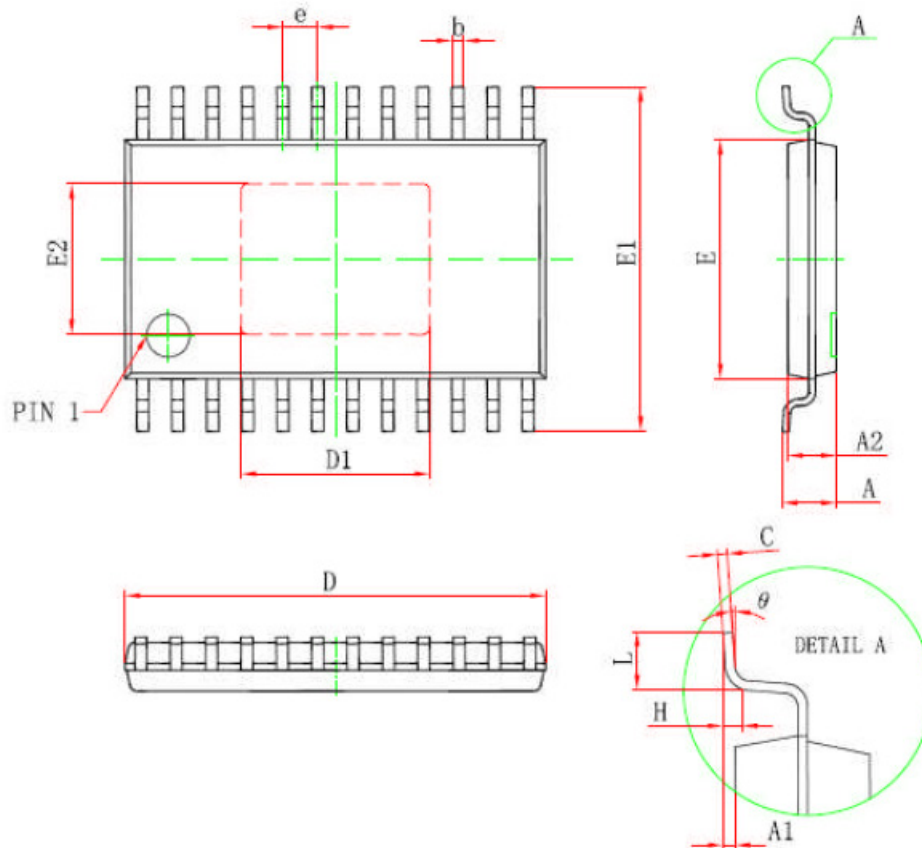

Symbol	Dimensions In Millimeters		Dimensions In Inches	
	Min	Max	Min	Max
D	7.700	7.900	0.303	0.311
D1	3.400	3.600	0.134	0.138
E	4.300	4.500	0.169	0.177
b	0.190	0.300	0.007	0.012
c	0.090	0.200	0.004	0.008
E1	6.250	6.350	0.246	0.258
E2	2.700	2.900	0.106	0.122
A		1.100		0.043
A2	0.800	1.000	0.031	0.039
A1	0.020	0.150	0.001	0.006
e	0.65 (BSC)		0.026 (BSC)	
L	0.500	0.700	0.02	0.028
H	0.25(TYP)		0.01(TYP)	
theta	1°	7°	1°	7°

IMPORTANT NOTICE

DIODES INCORPORATED MAKES NO WARRANTY OF ANY KIND, EXPRESS OR IMPLIED, WITH REGARDS TO THIS DOCUMENT, INCLUDING, BUT NOT LIMITED TO, THE IMPLIED WARRANTIES OF MERCHANTABILITY AND FITNESS FOR A PARTICULAR PURPOSE (AND THEIR EQUIVALENTS UNDER THE LAWS OF ANY JURISDICTION).

Diodes Incorporated and its subsidiaries reserve the right to make modifications, enhancements, improvements, corrections or other changes without further notice to this document and any product described herein. Diodes Incorporated does not assume any liability arising out of the application or use of this document or any product described herein; neither does Diodes Incorporated convey any license under its patent or trademark rights, nor the rights of others. Any Customer or user of this document or products described herein in such applications shall assume all risks of such use and will agree to hold Diodes Incorporated and all the companies whose products are represented on Diodes Incorporated website, harmless against all damages.

Diodes Incorporated does not warrant or accept any liability whatsoever in respect of any products purchased through unauthorized sales channel. Should Customers purchase or use Diodes Incorporated products for any unintended or unauthorized application, Customers shall indemnify and hold Diodes Incorporated and its representatives harmless against all claims, damages, expenses, and attorney fees arising out of, directly or indirectly, any claim of personal injury or death associated with such unintended or unauthorized application.

Products described herein may be covered by one or more United States, international or foreign patents pending. Product names and markings noted herein may also be covered by one or more United States, international or foreign trademarks.

This document is written in English but may be translated into multiple languages for reference. Only the English version of this document is the final and determinative format released by Diodes Incorporated.

LIFE SUPPORT

Diodes Incorporated products are specifically not authorized for use as critical components in life support devices or systems without the express written approval of the Chief Executive Officer of Diodes Incorporated. As used herein:

A. Life support devices or systems are devices or systems which:

1. are intended to implant into the body, or
2. support or sustain life and whose failure to perform when properly used in accordance with instructions for use provided in the labeling can be reasonably expected to result in significant injury to the user.

B. A critical component is any component in a life support device or system whose failure to perform can be reasonably expected to cause the failure of the life support device or to affect its safety or effectiveness.

Customers represent that they have all necessary expertise in the safety and regulatory ramifications of their life support devices or systems, and acknowledge and agree that they are solely responsible for all legal, regulatory and safety-related requirements concerning their products and any use of Diodes Incorporated products in such safety-critical, life support devices or systems, notwithstanding any devices- or systems-related information or support that may be provided by Diodes Incorporated. Further, Customers must fully indemnify Diodes Incorporated and its representatives against any damages arising out of the use of Diodes Incorporated products in such safety-critical, life support devices or systems.

Copyright © 2012, Diodes Incorporated

www.diodes.com

Looking for pricing, stock, or lifecycle information?

Click below to explore more details on WIN SOURCE:

-  [View PAM8615RHR on WIN SOURCE](#)
-  [Diodes Incorporated Information](#)

Optimize Your Supply Chain with WIN SOURCE Solutions

-  Global Sourcing Solution
-  Obsolete Management
-  Cost Control Management
-  Shortage Management
-  Alternative Solution
-  Excess Inventory Management