



THE DATASHEET OF PAM8012AZN



PAM8012

**MONO 2.0W ANTI-SATURATION CLASS-D
AUDIO POWER AMPLIFIER with POWER LIMIT**

Description

The PAM8012 is a 2.0W mono filterless class-D amplifier with high PSRR and differential input that reduce noise.

Features like 90% efficiency and small PCB area make the PAM8012 Class-D amplifier ideal for cellular handsets. The filterless architecture requires no external output filter, fewer external components, less PCB area and lower system costs, and simplifies application design.

The PAM8012 features anti-saturation function which detect output signal clip due to the over input level and keep the output non-saturation automatically to get the excellent sound quality.

The maximum output power without clip can be set by one resistor at PL pin that to prevent the speaker to be damaged.

The PAM8012 features short circuit protection and over temperature protection.

The PAM8012 is available in tiny WCSP9 (1.3mm x 1.3mm) and eMSOP10 packages.

Features

- 1.0W/2.0W @ <1% THD Output with a 8Ω/ 4Ω Load at 5V Supply
- Maximum Output Power Can Be Set by One External Resistor
- Minimized ON/OFF Pop Noise
- Superior Low Noise
- High PSRR
- Supply Voltage from 2.5V to 5.5V
- Auto Recovering Short Circuit Protection
- Over Temperature Protection
- 9 Ball, 1.3mm x 1.3mm, 0.4mm Pitch WCSP and eMSOP10 Packages

Applications

- Wireless or Cellular Handsets and PDAs
- Portable Navigation Devices
- General Portable Audio Devices

Pin Assignments

9 Ball 0.4mm pitch WCSP
Top View of PCB

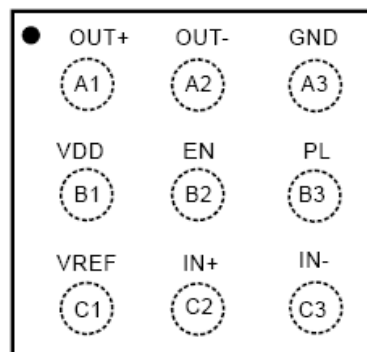

Top View
eMSOP10

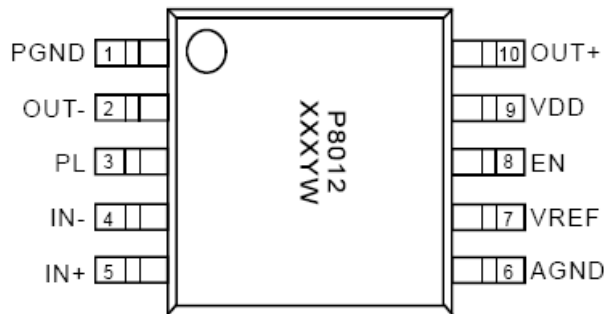

Typical Applications Circuit

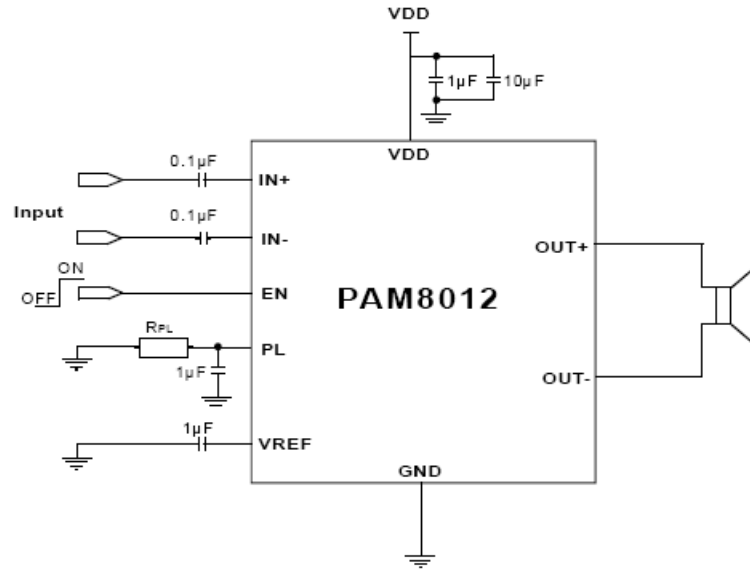

Functional Block Diagram

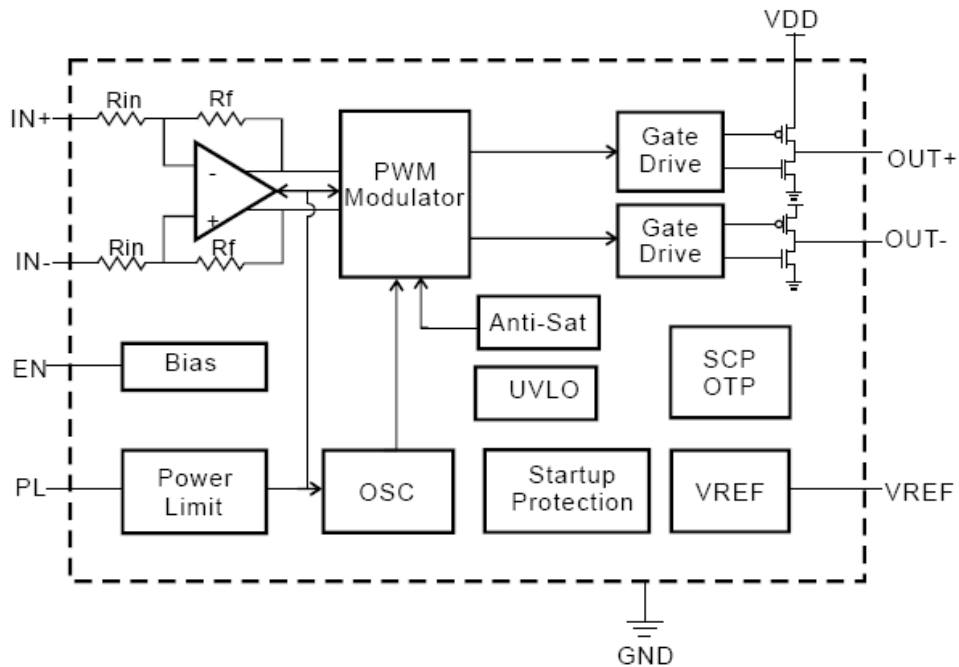

Absolute Maximum Ratings (@T_A = +25°C, unless otherwise specified.)

These are stress ratings only and functional operation is not implied. Exposure to absolute maximum ratings for prolonged time periods may affect device reliability. All voltages are with respect to ground.

Parameter	Rating	Unit
Supply Voltage, V _{DD}	6.0	V
Input Voltage, IN+, IN-	-0.3 to V _{DD} +0.3	
Minimum Load Resistance	3.2	Ω
Maximum Junction Temperature	-65 to +150	°C
Storage Temperature	150	
Soldering Temperature	260, 10sec	

Recommended Operating Conditions (@T_A = +25°C, unless otherwise specified.)

Parameter	Rating	Unit
Supply Voltage Range	2.5 to 5.5	V
Ambient Temperature Range	-40 to +85	°C
Junction Temperature Range	-40 to +125	

Thermal Information

Parameter	Package	Symbol	Max	Unit
Thermal Resistance (Junction to Ambient)	WCSP9 1.3 x 1.3	θ _{JA}	100	°C/W
	eMSOP10		60	
Thermal Resistance (Junction to Case)	WCSP9 1.3 x 1.3	θ _{JC}	40	
	eMSOP10		30	

Electrical Characteristics (@T_A = +25°C, V_{DD} = 5V, unless otherwise specified.)

Symbol	Parameter	Test Conditions		Min	Typ	Max	Units
V _{DD}	Supply Voltage			2.5		5.5	V
P _O	Output Power	R _{PL} = 110KΩ, f = 3kHz, R = 4Ω	V _{DD} = 5V		2.0		W
		R _{PL} = 110KΩ, f = 3kHz, R = 8Ω	V _{DD} = 5V		1.0		
THD+N	Total Harmonic Distortion Plus Noise	V _{DD} = 5V, P _O = 1W, R = 4Ω	f = 1kHz		0.08		
		V _{DD} = 3.6V, P _O = 2W, R = 4Ω			0.08		%
		V _{DD} = 5V, P _O = 1W, R = 8Ω	f = 1kHz		0.08		
		V _{DD} = 5V, P _O = 0.5W, R = 8Ω			0.08		%
PSRR	AC Power Supply Ripple Rejection	f = 217Hz, Inputs AC-Grounded with C _{IN} = 0.1μF	V _{DD} = 5.0V		-75		
			V _{DD} = 3.6V		-75		
SNR	Signal to Noise Ratio	THD = 1%, f = 1KHz	V _{DD} = 5.0V		95		dB
			V _{DD} = 3.6V		95		
V _N	Output Noise	C _{IN} = 0.1μF, Inputs AC-Grounded	No A-Weighting		60		
			A-Weighting		40		μV
η	Peak Efficiency	R _L = 8Ω	f = 1kHz		90		
		R _L = 4Ω			87		%
I _Q	Quiescent Current	V _{EN} = 5.0V, V _{DD} = 5V, PL = 0V	No Load		4.2		mA
I _{SD}	Shutdown Current	V _{DD} = 2.5V to 5.5V, V _{EN} = 0V	No Load			1	μA
V _{OS}	Offset Voltage	V _{DD} = 5V		-20		+20	mV
R _{IN}	Input Resistor	V _{DD} = 5V			31		KΩ
G _V	Closed Loop Gain	V _{DD} = 5V			18		dB
f _{SW}	Switching Frequency	V _{DD} = 5V			250		KHz
T _{ON}	Turn-On Time	V _{DD} = 5V			45		mS
OTP	Over Temperature Protection	V _{DD} = 5V	No Load		150		°C
OTH	Over Temperature Hysteresis	V _{DD} = 5V	No Load		40		°C
V _{ENH}	High-Level EN Voltage	V _{DD} = 5V		1.4			V
V _{ENL}	Low-Level EN Voltage	V _{DD} = 5V				0.4	V
AR	Maximum Attenuation Range	Anti-Saturation Active from +18dB to -18dB			26		dB

Typical Performance Characteristics (@ $T_A = +25^\circ\text{C}$, $V_{DD} = 5\text{V}$, unless otherwise specified.)

1. THD+N VS Output Power

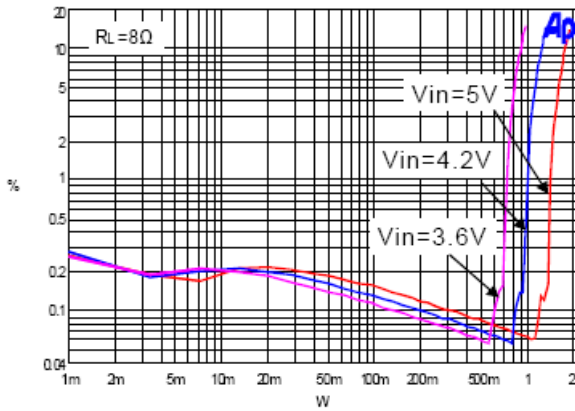

2. THD+N VS Output Power

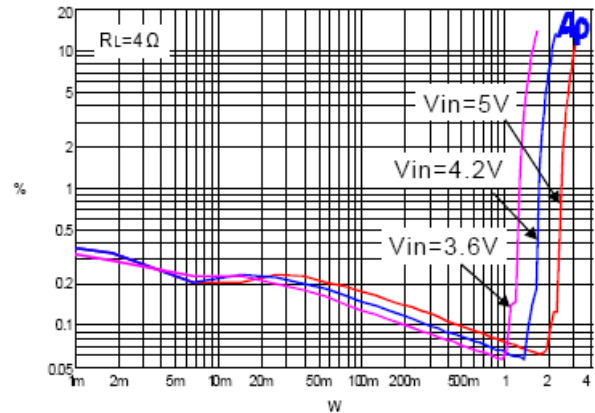

3. THD+N VS Frequency

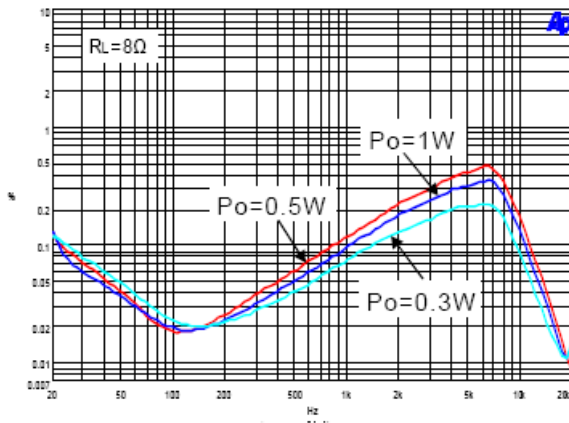

4. THD+N VS Frequency

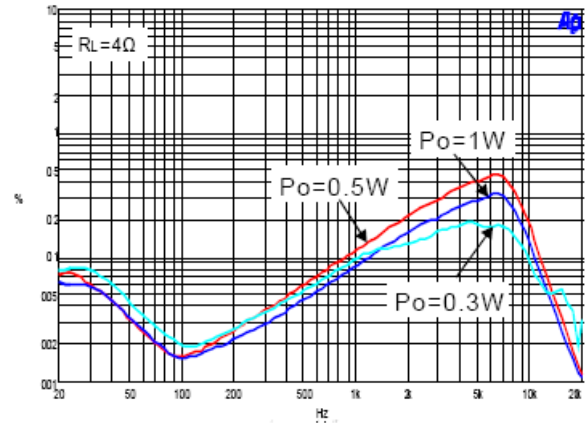

5. Frequency Response

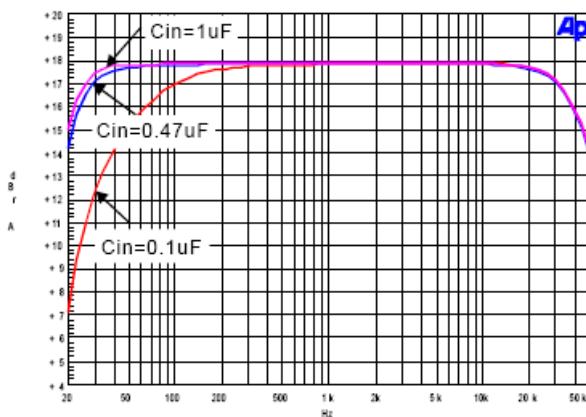

6. Frequency VS Supply Voltage

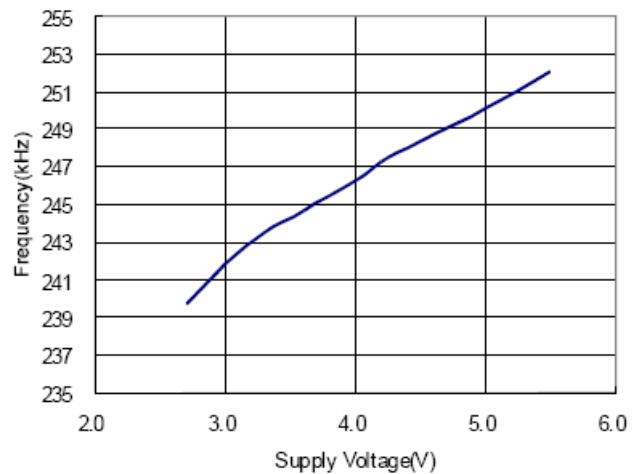

Typical Performance Characteristics (cont.) (@T_A = +25°C, V_{DD} = 5V, unless otherwise specified.)

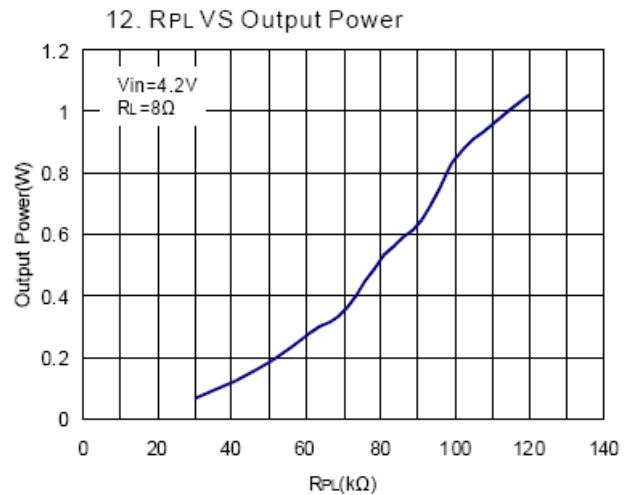
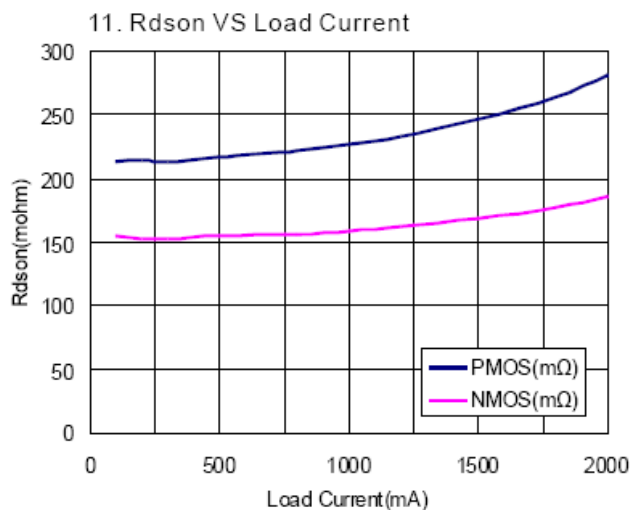
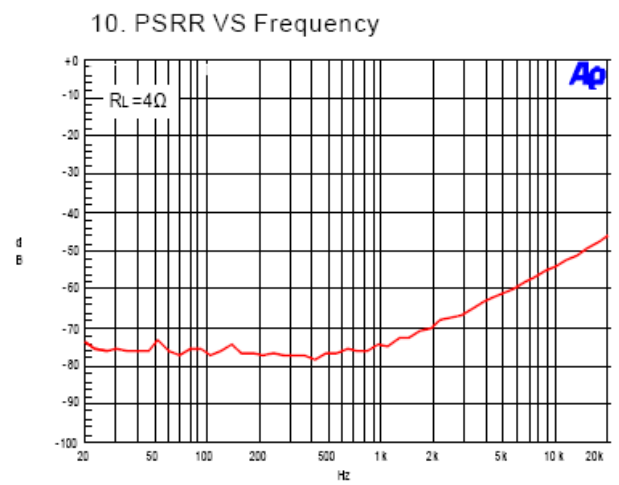
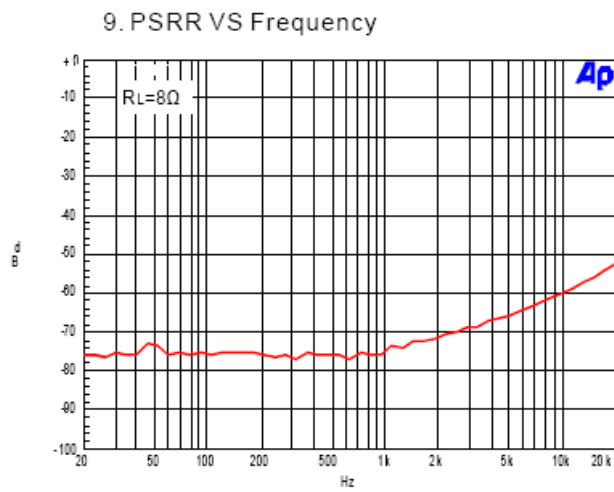
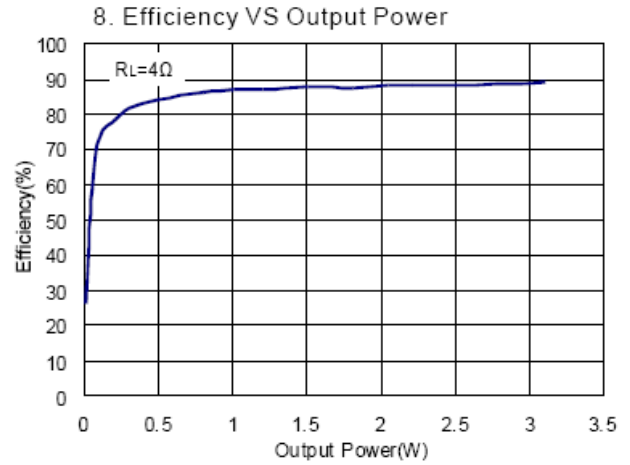
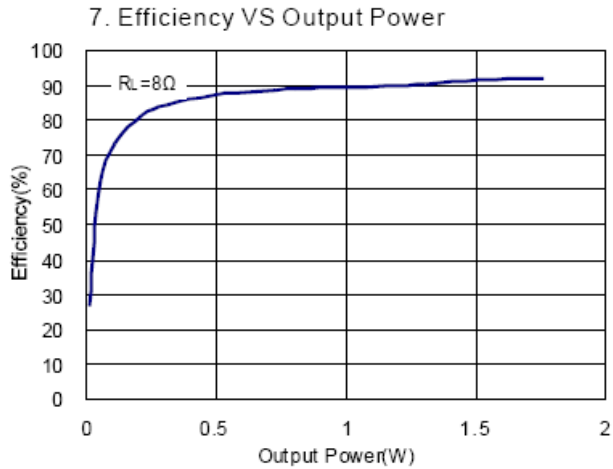

Application Information

Test Setup for Performance Testing

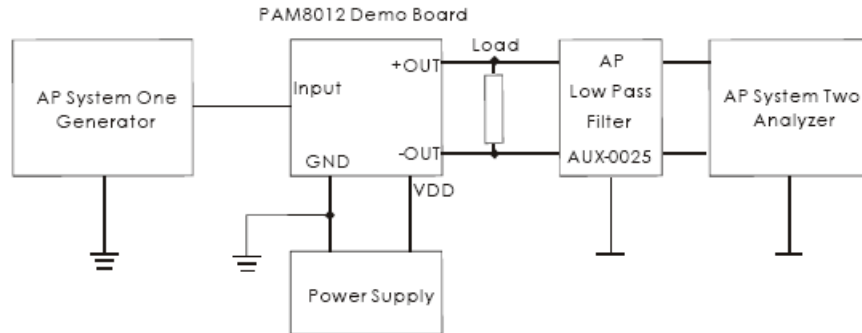

- Notes:
1. The AP AUX-0025 low pass filter is necessary for class-D amplifier measurement with AP analyzer.
 2. Two 33 μ H inductors are used in series with load resistor to emulate the small speaker for efficiency measurement.

Anti-Saturation

The Anti-saturation feature provides continuous automatic gain adjustment to the amplifier through an internal circuit. This feature enhances the perceived audio loudness and at the same time prevents speaker damage from occurring.

The Anti-saturation works by detecting the output. The gain changes depending on the supply voltage, and the attack and release time. The gain changes constantly as the audio signal increases and/or decreases. The gain step size for the Anti-saturation is 0.4 dB. If the audio signal has near-constant amplitude, the gain does not change. Table 1 shows the Anti-saturation variable description.

Table 1. PAM8012 Anti-Saturation Variable Description

Variable	Description	Value
Gain	The pre-set gain of the device when the Anti-saturation is inactive. The fixed gain is also the initial gain when the device comes out of shutdown mode or when the Anti-saturation is disabled.	18dB (Maximum)
Attack Time	The minimum time between two gain decrements.	128 μ S
Release Time	The minimum time between two gain increments.	256mS

PL Terminal Function

The voltage value of PL sets the PAM8012 maximum output by an external resistor. Refer to table 2 for anti-saturation and power limit selection.

Table 2. PAM8012 Anti-Saturation and Power Limit Variable Description

		R _{PL}		
		0	30K < R _{PL} < 120K	Open
EN	VDD	PL: OFF Anti-Sat: OFF	PL: ON Anti-Sat: ON	PL: OFF Anti-Sat: ON
	VDD/2	PL: OFF Anti-Sat: OFF	PL: ON Anti-Sat: OFF	PL: ON Anti-Sat: OFF

Application Information (cont.)

Input Capacitors (C_I)

In the typical application, an input capacitor, C_I, is required to allow the amplifier to bias the input signal to the proper DC level for optimum operation. In this case, C_I and the minimum input impedance R_I form a high-pass filter with the corner frequency determined in the following equation:

$$f_c = \frac{1}{2\pi R_I C_I}$$

It is important to consider the value of C_I as it directly affects the low frequency performance of the circuit. For example, the specification calls for a flat bass response are down to 150Hz.

Equation is reconfigured as followed:

$$C_I = \frac{1}{2\pi R_I f_l}$$

When input resistance variation is considered, the C_I is 34nF, so one would likely choose a value of 33nF. A further consideration for this capacitor is the leakage path from the input source through the input network (C_I, R_I + R_F) to the load. This leakage current creates a DC offset voltage at the input to the amplifier that reduces useful headroom, especially in high gain applications. For this reason, a low-leakage tantalum or ceramic capacitor is the best choice. When polarized capacitors are used, the positive side of the capacitor should face the amplifier input in most applications as the DC level is held at V_{DD}/2, which is likely higher than the source DC level. Please note that it is important to confirm the capacitor polarity in the application.

Decoupling Capacitor (C_S)

The PAM8012 is a high-performance CMOS audio amplifier that requires adequate power supply decoupling to ensure the output total harmonic distortion (THD) as low as possible. Power supply decoupling also prevents the oscillations causing by long lead length between the amplifier and the speaker.

The optimum decoupling is achieved by using two different types of capacitors that target on different types of noise on the power supply leads. For higher frequency transients, spikes, or digital hash on the line, a good low equivalent-series-resistance (ESR) ceramic capacitor, typically 1μF, is placed as close as possible to V_{DD} pin for the best operation. For filtering lower frequency noise signals, a large ceramic capacitor of 10μF or greater placed near the audio power amplifier is recommended.

How to Reduce EMI

Most applications require a ferrite bead filter for EMI elimination shown at Figure 1. The ferrite filter reduces EMI around 1MHz and higher. When selecting a ferrite bead, choose one with high impedance at high frequencies, but low impedance at low frequencies.

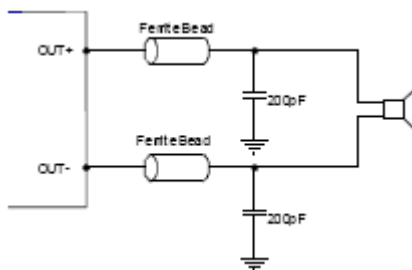

Figure 1: Ferrite Bead Filter to Reduce EMI

Shutdown Operation

In order to reduce power consumption while not in use, the PAM8012 contains shutdown circuitry that is used to turn off the amplifier's bias circuitry. This shutdown feature turns the amplifier off when logic low is placed on the EN pin. By switching the EN pin connected to GND, the PAM8012 supply current draw will be minimized in idle mode.

Short Circuit Protection (SCP)

The PAM8012 has short circuit protection circuitry on the outputs to prevent the device from damage when output-to-output shorts or output-to-GND shorts occur. When a short circuit occurs, the device immediately goes into shutdown state. Once the short is removed, the device will be reactivated.

Application Information (cont.)

Over Temperature Protection (OTP)

Thermal protection on the PAM8012 prevents the device from damage when the internal die temperature exceeds +150°C. There is a +15°C tolerance on this trip point from device to device. Once the die temperature exceeds the set point, the device will enter the shutdown state and the outputs are disabled. This is not a latched fault. The thermal fault is cleared once the temperature of the die decreased by +40°C. This large hysteresis will prevent motor boating sound well and the device begins normal operation at this point with no external system interaction.

POP and Click Circuitry

The PAM8012 contains circuitry to minimize turnon and turn-off transients or “click and pops”, where turn-on refers to either power supply turn-on or device recover from shutdown mode. When the device is turned on, the amplifiers are internally muted. An internal current source ramps up the reference voltage. The device will remain in mute mode until the reference voltage reach half supply voltage, $\frac{1}{2} V_{DD}$. As soon as the reference voltage is stable the device will begin full operation. For the best power-off pop performance, the amplifier should be set in shutdown mode prior to removing the power supply voltage.

PCB Layout Guidelines

Grounding

It is recommended to use plane grounding. Noise currents in the output power stage need to be returned to output noise ground and nowhere else. When these currents circulate elsewhere, they may get into the power supply, or the signal ground, etc, even worse, they may form a loop and radiate noise. Any of these instances results in degraded amplifier performance. The output noise ground that the logical returns for the output noise currents with Class-D switching must tie to system ground at the power exclusively. Signal currents for the inputs, reference need to be returned to quiet ground. This ground only ties to the signal components and the GND pin. GND then ties to system ground.

Power Supply Line

It is recommended that all the trace could be routed as short and thick as possible. For the power line layout, just imagine water stream, any barricade placed in the trace (shown in Figure 2) could result in the bad performance of the amplifier.

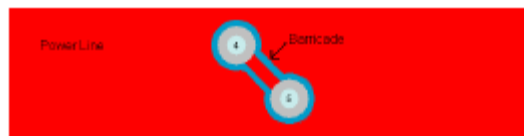

Figure 2: Power Line

Components Placement

Decoupling capacitors as previously described, the high-frequency 1μF decoupling capacitors should be placed as close to the power supply terminals V_{DD} as possible. Large bulk power supply decoupling capacitors (10μF or greater) should be placed near the PAM8012 on the V_{DD} terminal.

Input resistors and capacitors need to be placed very close to input pins.

Output filter - The ferrite EMI filter should be placed as close to the output terminals as possible for the best EMI performance, and the capacitors used in the filters should be grounded to system ground.

Ordering Information

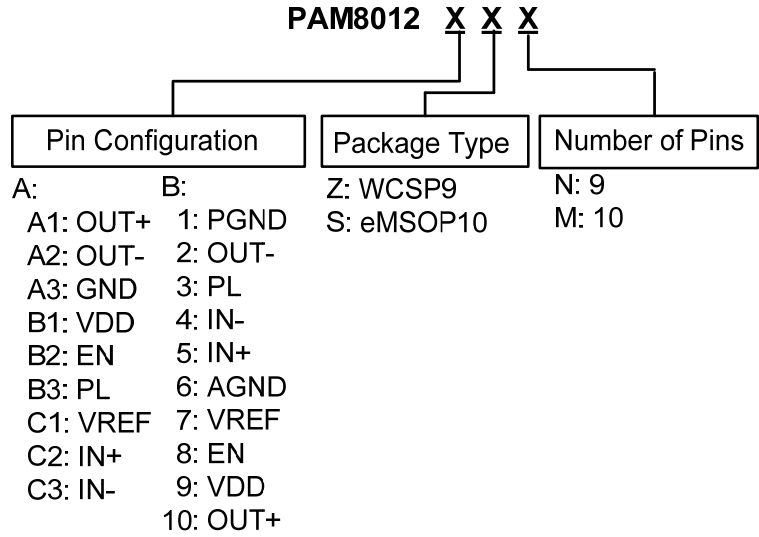

Part Number	Part Marking	Package Type	Standard Package
PAM8012AZN	BI YW	WCSP (1.3mm x 1.3mm)	3000 Units/Tape&Reel
PAM8012BSM	P8012 XXXYW	eMSOP10	2500 Units/Tape&Reel

Marking Information

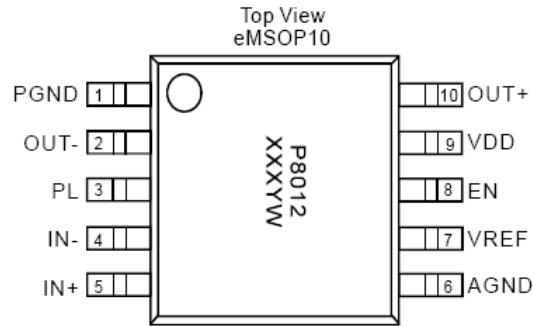

X: Internal Code
Y: Year
W: Week

9 Ball 0.4mm pitch WCSP
Top View of Marking

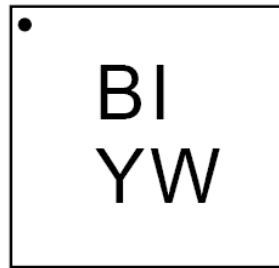

BI: Product Code of PAM8012
Y: Year
W: Week

Package Outline Dimensions (All dimensions in mm.)

WCSP9

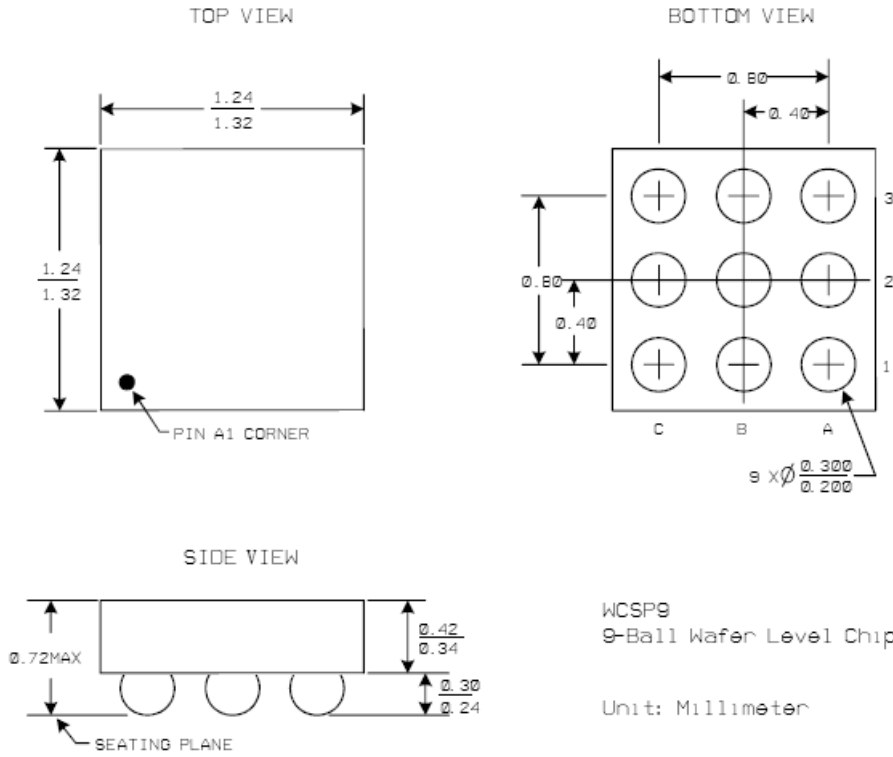

WCSP9
9-Ball Wafer Level Chip Scale Package

Unit: Millimeter

Package Outline Dimensions (cont.) (All dimensions in mm.)

eMSOP10

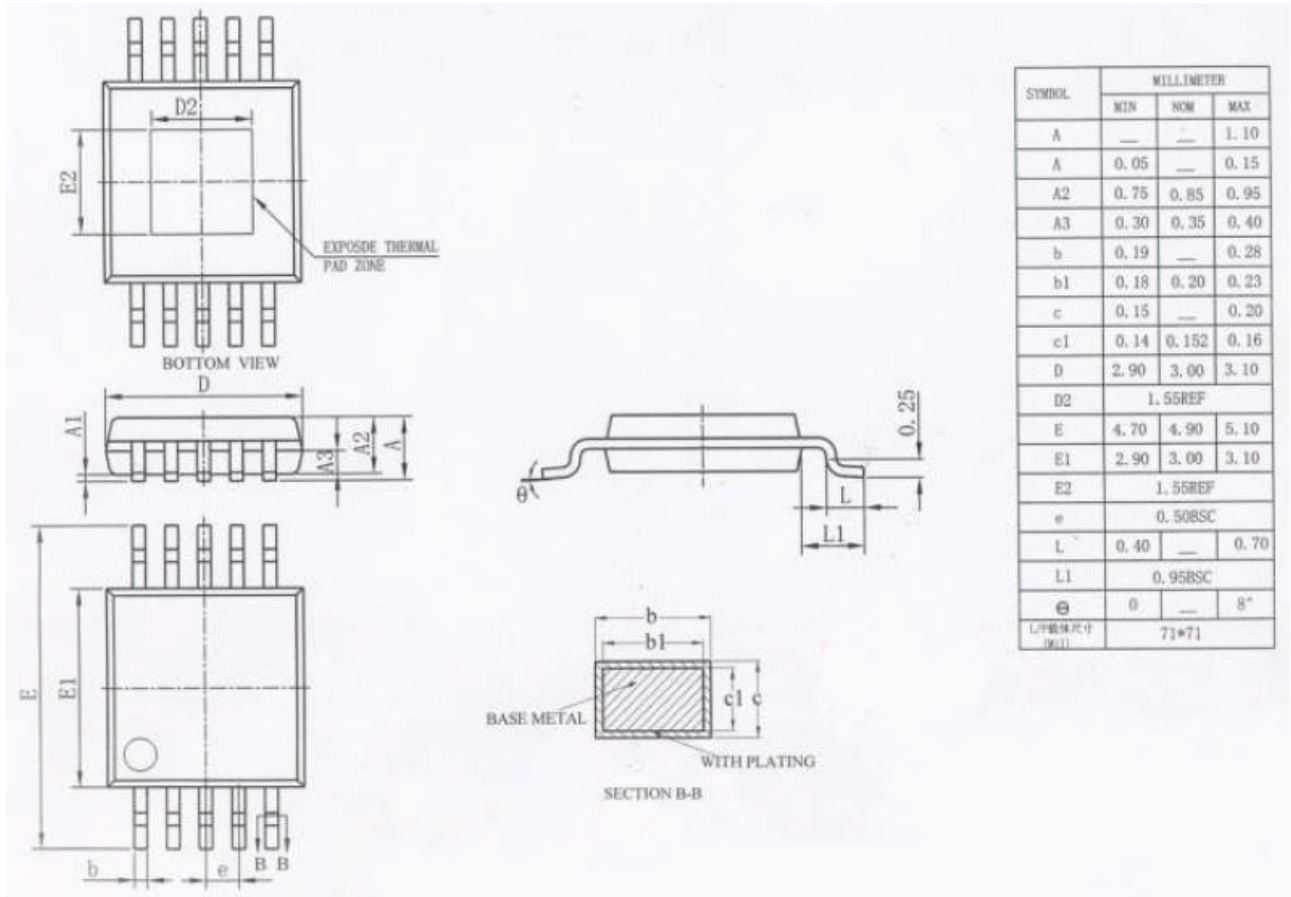

IMPORTANT NOTICE

DIODES INCORPORATED MAKES NO WARRANTY OF ANY KIND, EXPRESS OR IMPLIED, WITH REGARDS TO THIS DOCUMENT, INCLUDING, BUT NOT LIMITED TO, THE IMPLIED WARRANTIES OF MERCHANTABILITY AND FITNESS FOR A PARTICULAR PURPOSE (AND THEIR EQUIVALENTS UNDER THE LAWS OF ANY JURISDICTION).

Diodes Incorporated and its subsidiaries reserve the right to make modifications, enhancements, improvements, corrections or other changes without further notice to this document and any product described herein. Diodes Incorporated does not assume any liability arising out of the application or use of this document or any product described herein; neither does Diodes Incorporated convey any license under its patent or trademark rights, nor the rights of others. Any Customer or user of this document or products described herein in such applications shall assume all risks of such use and will agree to hold Diodes Incorporated and all the companies whose products are represented on Diodes Incorporated website, harmless against all damages.

Diodes Incorporated does not warrant or accept any liability whatsoever in respect of any products purchased through unauthorized sales channel. Should Customers purchase or use Diodes Incorporated products for any unintended or unauthorized application, Customers shall indemnify and hold Diodes Incorporated and its representatives harmless against all claims, damages, expenses, and attorney fees arising out of, directly or indirectly, any claim of personal injury or death associated with such unintended or unauthorized application.

Products described herein may be covered by one or more United States, international or foreign patents pending. Product names and markings noted herein may also be covered by one or more United States, international or foreign trademarks.

This document is written in English but may be translated into multiple languages for reference. Only the English version of this document is the final and determinative format released by Diodes Incorporated.

LIFE SUPPORT

Diodes Incorporated products are specifically not authorized for use as critical components in life support devices or systems without the express written approval of the Chief Executive Officer of Diodes Incorporated. As used herein:

A. Life support devices or systems are devices or systems which:

1. are intended to implant into the body, or
2. support or sustain life and whose failure to perform when properly used in accordance with instructions for use provided in the labeling can be reasonably expected to result in significant injury to the user.

B. A critical component is any component in a life support device or system whose failure to perform can be reasonably expected to cause the failure of the life support device or to affect its safety or effectiveness.

Customers represent that they have all necessary expertise in the safety and regulatory ramifications of their life support devices or systems, and acknowledge and agree that they are solely responsible for all legal, regulatory and safety-related requirements concerning their products and any use of Diodes Incorporated products in such safety-critical, life support devices or systems, notwithstanding any devices- or systems-related information or support that may be provided by Diodes Incorporated. Further, Customers must fully indemnify Diodes Incorporated and its representatives against any damages arising out of the use of Diodes Incorporated products in such safety-critical, life support devices or systems.

Copyright © 2012, Diodes Incorporated

www.diodes.com

Looking for pricing, stock, or lifecycle information?

Click below to explore more details on WIN SOURCE:

-  [View PAM8012AZN on WIN SOURCE](#)
-  [Diodes Incorporated Information](#)

Optimize Your Supply Chain with WIN SOURCE Solutions

-  Global Sourcing Solution
-  Obsolete Management
-  Cost Control Management
-  Shortage Management
-  Alternative Solution
-  Excess Inventory Management