



**THE DATASHEET OF
PAM2812ABR**



PART OBSOLETE

PAM2812

4-CHANNEL LOW DROPOUT CURRENT SINK

Description

The PAM2812 provides 4 regulated current sinks, capable of sinking up to 20mA current to accommodate 4 white LEDs. It requires no charge pump, has no noise and EMI, and significantly improves the efficiency in Li battery range.

LED brightness can be controlled by EN PWM dimming techniques.

The PAM2812 is available in SOT23-6L package.

Features

- Support up to 4 LEDs
- LED sink current 20mA
- Low Dropout Voltage
- Low Quiescent Supply Current:330µA(typ)
- No Noise and EMI
- Shutdown Current Less than 1µA
- Over Temperature Protection
- Small Package: SOT23-6L
- RoHS Compliant and Green Package

Pin Assignments

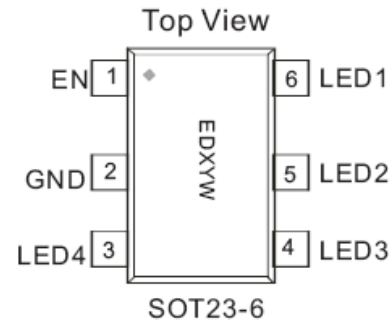

Applications

- Mobile Phone
- Digital Camera
- PDA,MP3,MP4

Typical Applications Circuit

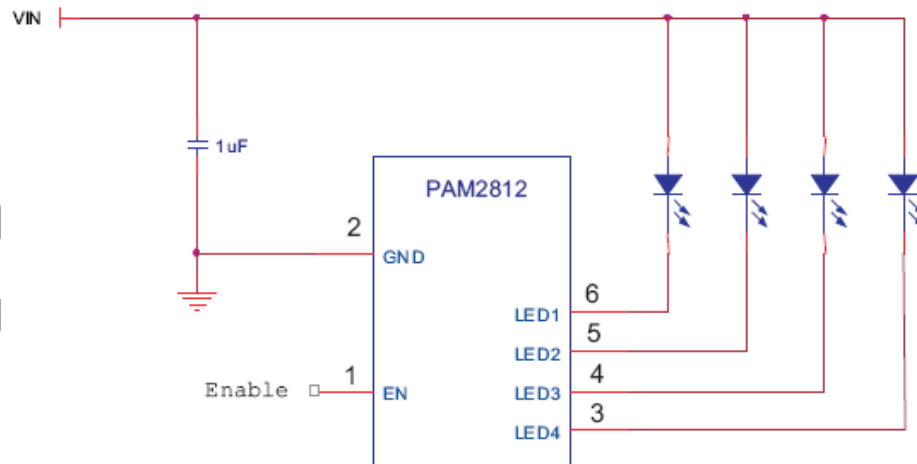

OBSOLETE - PART DISCONTINUED

Pin Descriptions

Pin Number	Pin Name	Function
1	EN	Enable Pin. Active high.
2	GND	Ground
3	LED4	LED4 Pin, Connect to the LED cathode, leave it to connect GND or open if unused.
4	LED3	LED3 Pin, Connect to the LED cathode, leave it to connect GND or open if unused.
5	LED2	LED2 Pin, Connect to the LED cathode, leave it to connect GND or open if unused.
6	LED1	LED1 Pin, Connect to the LED cathode, leave it to connect GND or open if unused.

Functional Block Diagram

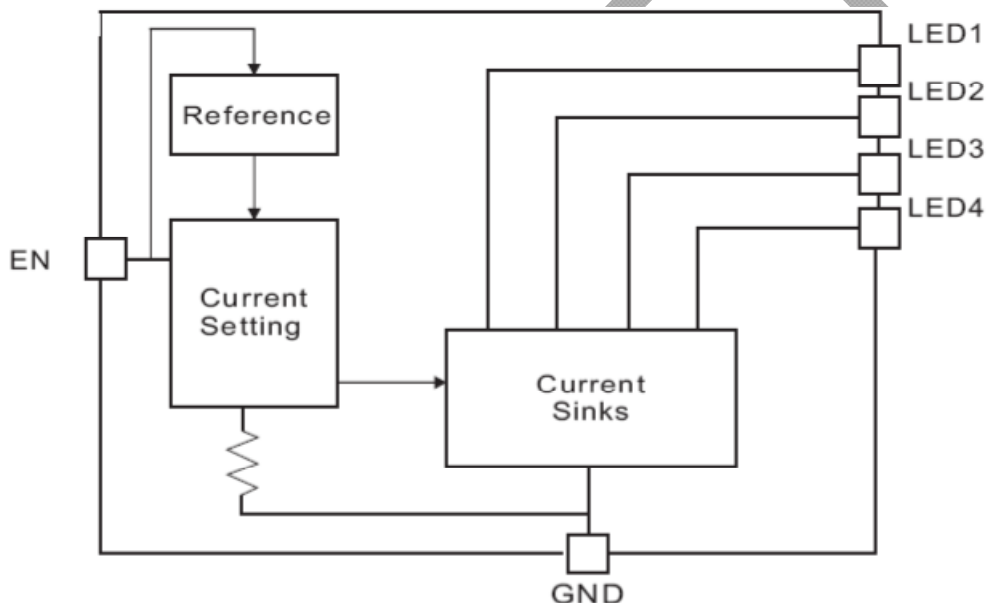

Absolute Maximum Ratings (@T_A = +25°C, unless otherwise specified.)

These are stress ratings only and functional operation is not implied. Exposure to absolute maximum ratings for prolonged time periods may affect device reliability. All voltages are with respect to ground.

Parameter	Rating	Unit
EN Voltage Range	-0.3 to +6.0	V
Input Voltage Range	-0.3 to +6.0	V
The Other Pins	-0.3 to +6.0	V
Maximum Junction Temperature	150	°C
Storage Temperature	-65 to +165	
Soldering Temperature	300, 5sec	

Recommended Operating Conditions (@T_A = +25°C, unless otherwise specified.)

Parameter	Rating	Unit
EN Voltage Range	2.7 to 5.5	V
Junction Temperature Range	-40 to +125	°C
Ambient Temperature Range	-40 to +85	

Thermal Information

Parameter	Package	Symbol	Max	Unit
Thermal Resistance (Junction to Ambient)	SOT23-6L	θ _{JA}	250	°C/W
Thermal Resistance (Junction to Case)	SOT23-6L	θ _{JC}	130	
Internal Power Dissipation	SOT23-6L	P _D	400	mW

Electrical Characteristics (Note 1) (@T_A = +25°C, V_{IN} = 3.6V, unless otherwise specified.)

Parameter	Symbol	Test Conditions	Min	Typ	Max	Units
Operation Voltage Range	V _{EN}		2.7		5.5	V
LED Sink Current	I _{LED}	All LEDs 100% setting	18	20	22	mA
LED Current Matching		All LEDs 100% setting			5	%
LED Dropout Voltage	V _{DO}	I _{LED} = 20mA		180		mV
Quiescent Current	I _Q	I _{LED} = 0		330	500	µA
Shutdown Current	I _{SD}	V _{EN} = 0V			1	µA
Startup Time	T _{ON}			3		µs
EN Input Logic High	V _{HI}		2.7			V
EN Input Logic Low	V _{LO}				0.4	V
Thermal Shutdown Temperature	T _P			150		°C
Hysteresis Temperature				30		°C

Note: 1. Recommend EN pin maximum PWM dimming frequency is 1Khz. Recommended EN pin minimum PWM dimming pulse width is 100µs.

PART OBSOLETE

PAM2812

OBSOLETE - PART DISCONTINUED

Typical Performance Characteristics (@ $T_A = +25^\circ\text{C}$, EN = 5.0V, unless otherwise specified.)

LED Current VS LED Pin Voltage

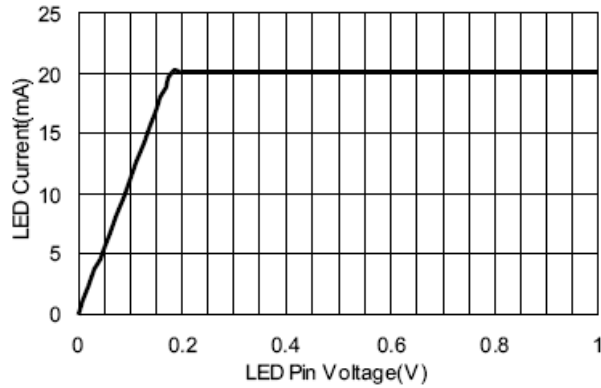

LED Current VS Input Voltage

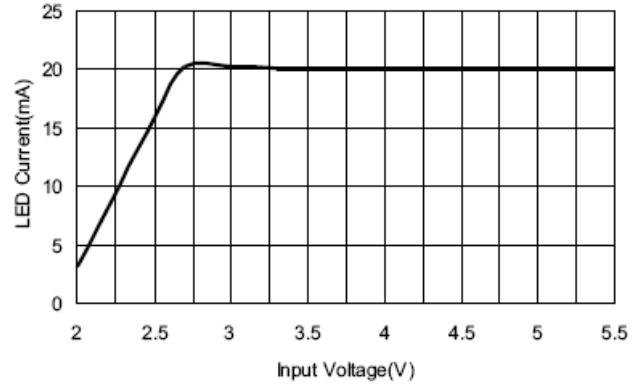

Efficiency VS Input Voltage

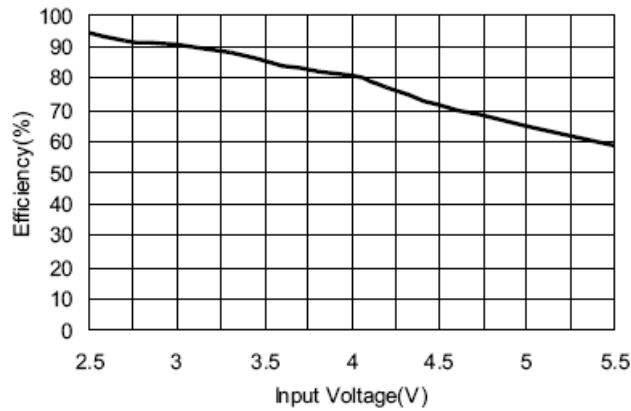

OBSOLETE

PART OBSOLETE

PAM2812

OBSOLETE – PART DISCONTINUED

Application Information

The PAM2812 is a 4-channel programmable white-LED driver. It is capable of supplying 20mA per channel with a total of 80mA output current available. LED brightness control of PAM2812 can be achieved with a pulses signal.

Enable Input

The EN input is used to enable or disable the PAM2812. Pulling the EN pin higher than 2.7V will enable the device. For producing constant, nonpulsating output current compare to conventional pulse width modulation (PWM) dimming scheme. A constant current is sourced as long as the EN signal remains high. The shutdown feature reduces quiescent current to less than 0.1µA.

LED Connection

The PAM2812 supports up to 4 white LEDs. The four LEDs are connected from VIN to LEDx respectively. If the LED is not used, it should be connected to GND or open.

Over Temperature Protection

The PAM2812 equips over temperature protection. When the junction temperature (T_J) exceeds +150°C, the current source turns off automatically. The device will turn on again after the IC's T_J cools down under +120°C. Operating at absolute maximum temperature is not recommended.

LED Brightness Dimming Control

For controlling the LED brightness, the PAM2812 can perform the dimming control by applying a PWM signal to EN pin. When an external PWM signal is connected to the EN pin, brightness of white LED is adjusted by the duty cycle. The average LED current is proportional to the PWM signal duty cycle. The magnitude of the PWM signal must be higher than the minimum level of enable input high level, in order to let the dimming control perform correctly, the suggested PWM frequency range is 1kHz to 200Hz.

Ordering Information

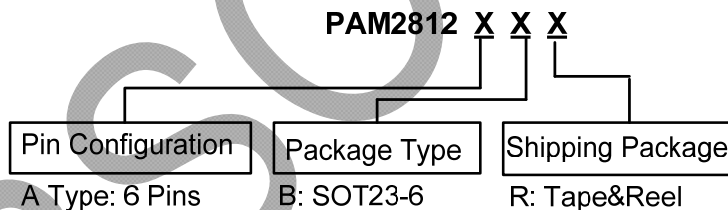

Part Number	Part Marking	Package Type	Standard Package
PAM2812ABR	EDXYW	SOT23-6	3000 Units/Tape&Reel

Marking Information

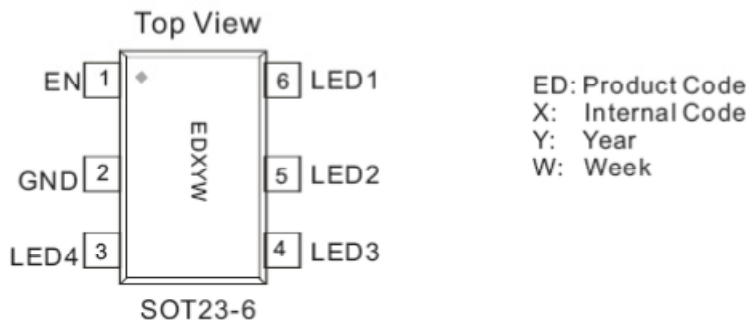

PART OBSOLETE

PAM2812

Package Outline Dimensions (All dimensions in mm.)

SOT23-6L

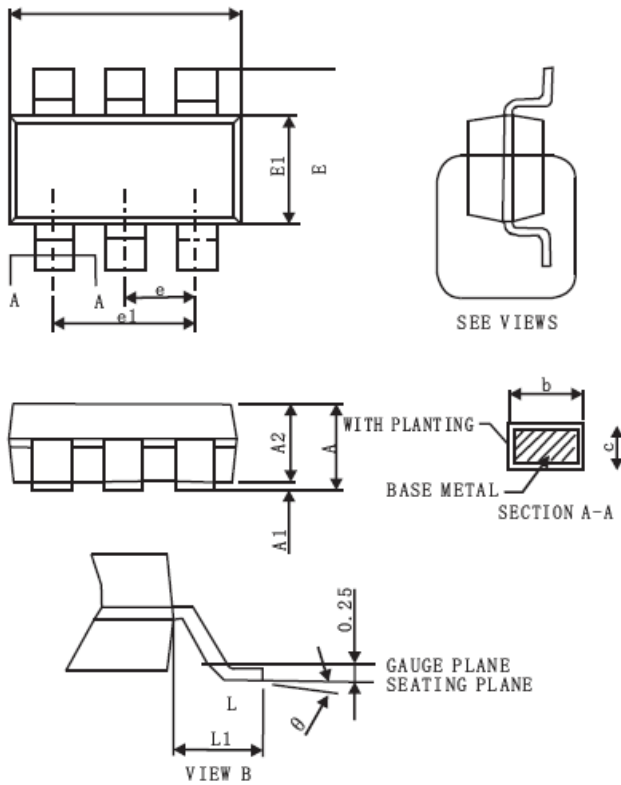

Symbol	A	A1	A2	b	c	D	E
Spec	1.20±0.25	0.10±0.05	1.10±0.2	0.40±0.1	0.15±0.07	2.90±0.1	2.80±0.2
Symbol	E11	e	e1	L	L1	θ	
Spec	1.60±0.1	0.95BSC	1.90BSC	0.55±0.25	0.60REF	4°±4°	

OBSOLETE - PART DISCONTINUED

PART OBSOLETE**PAM2812****IMPORTANT NOTICE**

DIODES INCORPORATED MAKES NO WARRANTY OF ANY KIND, EXPRESS OR IMPLIED, WITH REGARDS TO THIS DOCUMENT, INCLUDING, BUT NOT LIMITED TO, THE IMPLIED WARRANTIES OF MERCHANTABILITY AND FITNESS FOR A PARTICULAR PURPOSE (AND THEIR EQUIVALENTS UNDER THE LAWS OF ANY JURISDICTION).

Diodes Incorporated and its subsidiaries reserve the right to make modifications, enhancements, improvements, corrections or other changes without further notice to this document and any product described herein. Diodes Incorporated does not assume any liability arising out of the application or use of this document or any product described herein; neither does Diodes Incorporated convey any license under its patent or trademark rights, nor the rights of others. Any Customer or user of this document or products described herein in such applications shall assume all risks of such use and will agree to hold Diodes Incorporated and all the companies whose products are represented on Diodes Incorporated website, harmless against all damages.

Diodes Incorporated does not warrant or accept any liability whatsoever in respect of any products purchased through unauthorized sales channel. Should Customers purchase or use Diodes Incorporated products for any unintended or unauthorized application, Customers shall indemnify and hold Diodes Incorporated and its representatives harmless against all claims, damages, expenses, and attorney fees arising out of, directly or indirectly, any claim of personal injury or death associated with such unintended or unauthorized application.

Products described herein may be covered by one or more United States, international or foreign patents pending. Product names and markings noted herein may also be covered by one or more United States, international or foreign trademarks.

This document is written in English but may be translated into multiple languages for reference. Only the English version of this document is the final and determinative format released by Diodes Incorporated.

LIFE SUPPORT

Diodes Incorporated products are specifically not authorized for use as critical components in life support devices or systems without the express written approval of the Chief Executive Officer of Diodes Incorporated. As used herein:

A. Life support devices or systems are devices or systems which:

1. are intended to implant into the body, or
2. support or sustain life and whose failure to perform when properly used in accordance with instructions for use provided in the labeling can be reasonably expected to result in significant injury to the user.

B. A critical component is any component in a life support device or system whose failure to perform can be reasonably expected to cause the failure of the life support device or to affect its safety or effectiveness.

Customers represent that they have all necessary expertise in the safety and regulatory ramifications of their life support devices or systems, and acknowledge and agree that they are solely responsible for all legal, regulatory and safety-related requirements concerning their products and any use of Diodes Incorporated products in such safety-critical, life support devices or systems, notwithstanding any devices- or systems-related information or support that may be provided by Diodes Incorporated. Further, Customers must fully indemnify Diodes Incorporated and its representatives against any damages arising out of the use of Diodes Incorporated products in such safety-critical, life support devices or systems.

Copyright © 2012, Diodes Incorporated

www.diodes.com

OBSOLETE – PART DISCONTINUED

Looking for pricing, stock, or lifecycle information?

Click below to explore more details on WIN SOURCE:

-  [View PAM2812ABR on WIN SOURCE](#)
-  [Diodes Incorporated Information](#)

Optimize Your Supply Chain with WIN SOURCE Solutions

-  Global Sourcing Solution
-  Obsolete Management
-  Cost Control Management
-  Shortage Management
-  Alternative Solution
-  Excess Inventory Management