

# P89LPC901/902/903

8-bit microcontrollers with two-clock 80C51 core  
1 kB 3 V Flash with 128-byte RAM

Rev. 05 — 17 December 2004

Product data

## 1. General description

---

The P89LPC901/902/903 are single-chip microcontrollers in low-cost 8-pin packages, based on a high performance processor architecture that executes instructions in two to four clocks, six times the rate of standard 80C51 devices. Many system-level functions have been incorporated into the P89LPC901/902/903 in order to reduce component count, board space, and system cost.

## 2. Features

---

### 2.1 Principal features

- 1 kB byte-erasable Flash code memory organized into 256-byte sectors and 16-byte pages. Single-byte erasing allows any byte(s) to be used as non-volatile data storage.
- 128-byte RAM data memory.
- Two 16-bit counter/timers. (P89LPC901 Timer 0 may be configured to toggle a port output upon timer overflow or to become a PWM output.)
- 23-bit system timer that can also be used as a Real-Time clock.
- Two analog comparators (P89LPC902 and P89LPC903, single analog comparator on P89LPC901).
- Enhanced UART with fractional baudrate generator, break detect, framing error detection, automatic address detection and versatile interrupt capabilities (P89LPC903).
- High-accuracy internal RC oscillator option allows operation without external oscillator components. The RC oscillator (factory calibrated to  $\pm 1\%$ ) option is selectable and fine tunable.
- 2.4 V to 3.6 V  $V_{DD}$  operating range with 5 V tolerant I/O pins (may be pulled up or driven to 5.5 V). Industry-standard pinout with  $V_{DD}$ ,  $V_{SS}$ , and reset at locations 1, 8, and 4.
- Up to six I/O pins when using internal oscillator and reset options.
- 8-pin SO-8 package.

### 2.2 Additional features

- A high performance 80C51 CPU provides instruction cycle times of 111 ns to 222 ns for all instructions except multiply and divide when executing at 18 MHz (167 ns to 333 ns at 12 MHz). This is six times the performance of the standard 80C51 running at the same clock frequency. A lower clock frequency for the same performance results in power savings and reduced EMI.
- In-Application Programming (IAP-Lite) and byte erase allows code memory to be used for non-volatile data storage.



**PHILIPS**

- Serial Flash In-Circuit Programming (ICP) allows simple production coding with commercial EPROM programmers. Flash security bits prevent reading of sensitive application programs.
- Watchdog timer with separate on-chip oscillator, requiring no external components. The watchdog prescaler is selectable from 8 values.
- Low voltage reset (Brownout detect) allows a graceful system shutdown when power fails. May optionally be configured as an interrupt.
- Idle and two different Power-down reduced power modes. Improved wake-up from Power-down mode (a low interrupt input starts execution). Typical Power-down current is 1  $\mu$ A (total Power-down with voltage comparators disabled).
- Active-LOW reset. On-chip power-on reset allows operation without external reset components. A reset counter and reset glitch suppression circuitry prevent spurious and incomplete resets. A software reset function is also available.
- Configurable on-chip oscillator with frequency range options selected by user programmed Flash configuration bits. Oscillator options support frequencies from 20 kHz to the maximum operating frequency of 18 MHz (P89LPC901).
- Watchdog timer with separate on-chip oscillator, requiring no external components. The watchdog prescaler is selectable from 8 values.
- Programmable port output configuration options: quasi-bidirectional, open drain, push-pull, input-only.
- Port 'input pattern match' detect. Port 0 may generate an interrupt when the value of the pins match or do not match a programmable pattern.
- LED drive capability (20 mA) on all port pins. A maximum limit is specified for the entire chip.
- Controlled slew rate port outputs to reduce EMI. Outputs have approximately 10 ns minimum ramp times.
- Only power and ground connections are required to operate the P89LPC901/902/903 when internal reset option is selected.
- Four interrupt priority levels.
- Two (P89LPC901), three (P89LPC903), or five (P89LPC902) keypad interrupt inputs.
- Second data pointer.
- Schmitt trigger port inputs.
- Emulation support.

### 3. Ordering information

Table 1: Ordering information

Type number	Package		
	Name	Description	Version
P89LPC901FD	SO8	plastic small outline package; 8 leads; body width 7.5 mm	SOT96-1
P89LPC902FD			
P89LPC903FD			
P89LPC901FN	DIP8	plastic dual in-line package; 8 leads (300 mil)	SOT97-1
P89LPC902FN			

#### 3.1 Ordering options

Table 2: Part options

Type number	Temperature range	Frequency
P89LPC901xx	−40 °C to +85 °C	0 MHz to 18 MHz
P89LPC902xx		Internal RC or watchdog
P89LPC903xx		Internal RC or watchdog

### 4. Block diagram

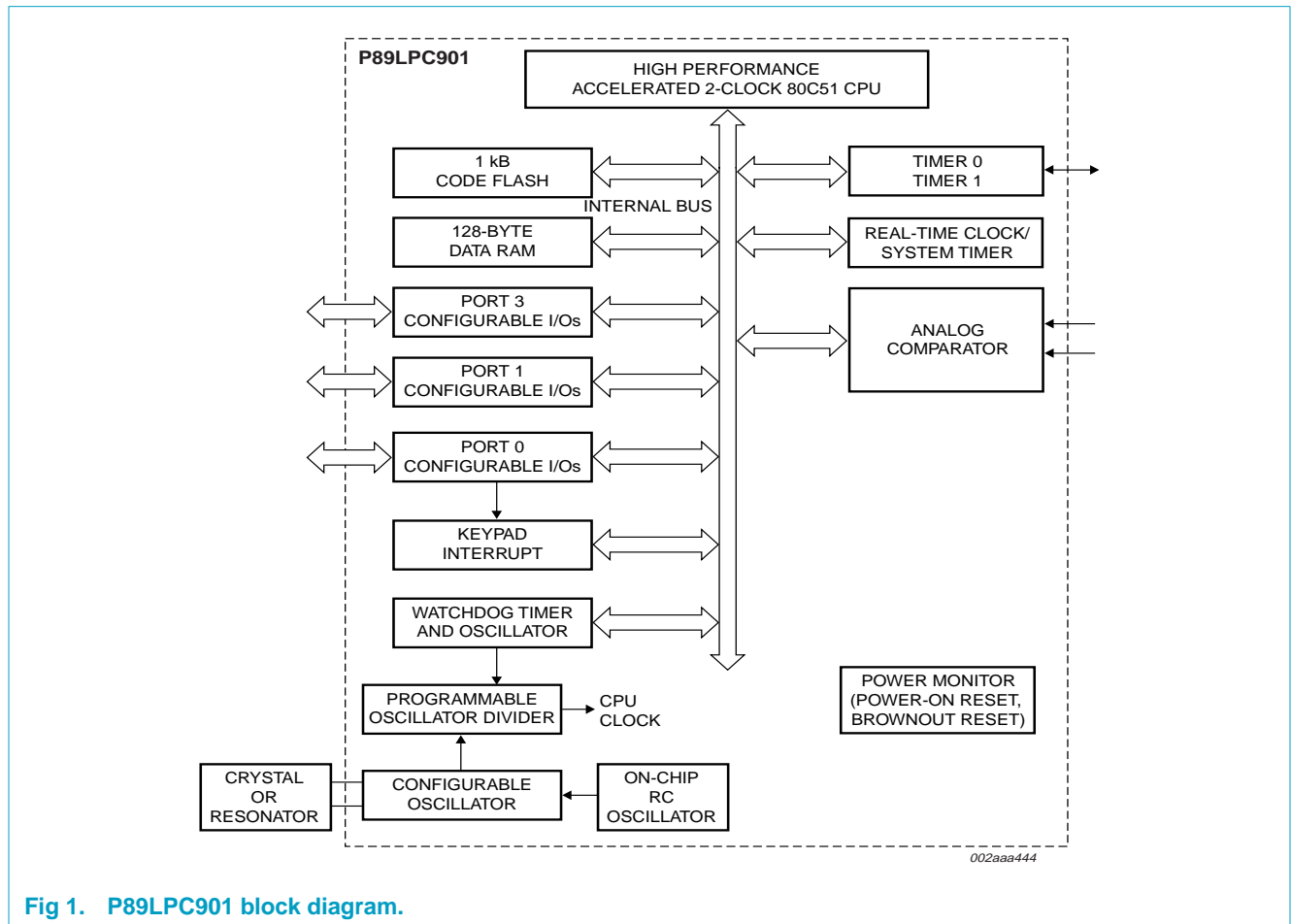
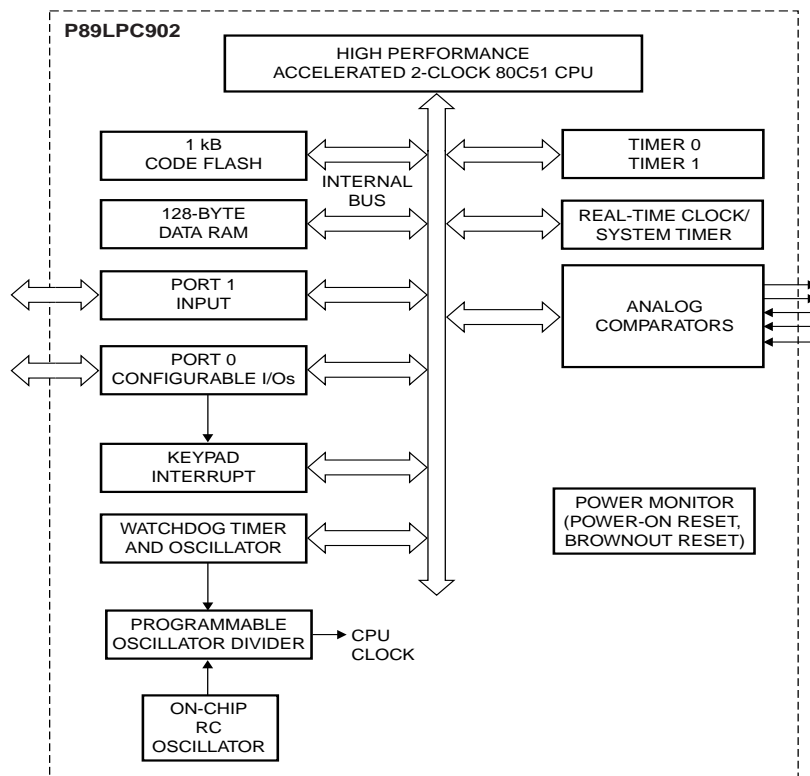
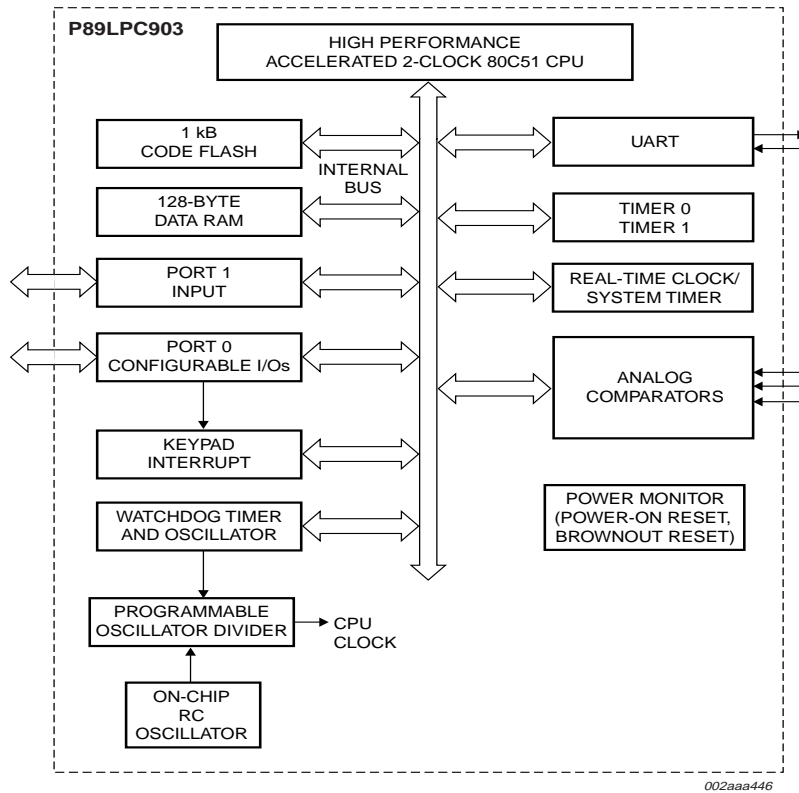

Fig 1. P89LPC901 block diagram.



002aaa445

Fig 2. P89LPC902 block diagram.



002aaa446

Fig 3. P89LPC903 block diagram.

## 5. Pinning information

### 5.1 Pinning

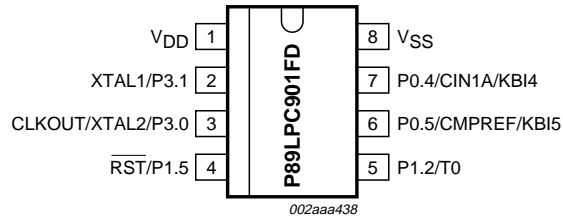

Fig 4. P89LPC901 pinning (SO8).

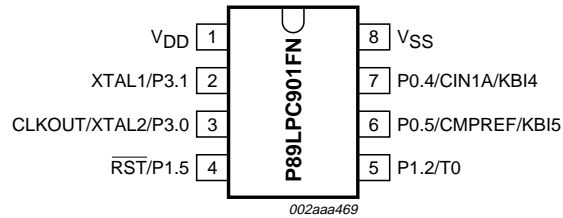

Fig 5. P89LPC901 pinning (DIP8).

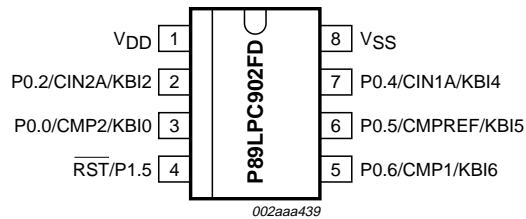

Fig 6. P89LPC902 pinning (SO8).

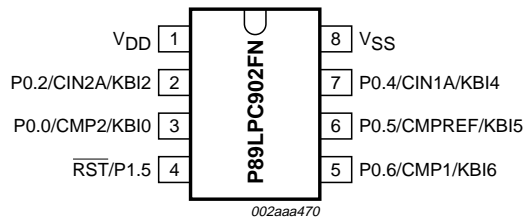

Fig 7. P89LPC902 pinning (DIP8).

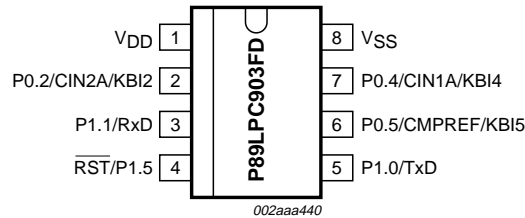

Fig 8. P89LPC903 pinning (SO8).

## 5.2 Pin description

Table 3: P89LPC901 pin description

Symbol	Pin	Type	Description
P0.0 to P0.6		I/O	<p><b>Port 0:</b> Port 0 is an I/O port with a user-configurable output type. During reset Port 0 latches are configured in the input only mode with the internal pull-up disabled. The operation of Port 0 pins as inputs and outputs depends upon the port configuration selected. Each port pin is configured independently. Refer to <a href="#">Section 8.12.1 "Port configurations"</a> and <a href="#">Table 13 "DC electrical characteristics"</a> for details.</p> <p>The Keypad Interrupt feature operates with Port 0 pins.</p> <p>All pins have Schmitt triggered inputs.</p> <p>Port 0 also provides various special functions as described below:</p>
	7	I/O	<b>P0.4</b> — Port 0 bit 4.
		I	<b>CIN1A</b> — Comparator 1 positive input.
		I	<b>KBI4</b> — Keyboard input 4.
	6	I/O	<b>P0.5</b> — Port 0 bit 5.
		I	<b>CMPREF</b> — Comparator reference (negative) input.
		I	<b>KBI5</b> — Keyboard input 5.

Table 3: P89LPC901 pin description...continued

Symbol	Pin	Type	Description
P1.0 to P1.5			<p><b>Port 1:</b> Port 1 is an I/O port with a user-configurable output type. During reset Port 1 latches are configured in the input only mode with the internal pull-up disabled. The operation of the configurable Port 1 pins as inputs and outputs depends upon the port configuration selected. Each of the configurable port pins are programmed independently. Refer to <a href="#">Section 8.12.1 "Port configurations"</a> and <a href="#">Table 13 "DC electrical characteristics"</a> for details. P1.5 is input only.</p> <p>All pins have Schmitt triggered inputs.</p> <p>Port 1 also provides various special functions as described below:</p>
	5	I/O	<b>P1.2</b> — Port 1 bit 2.
		O	<b>T0</b> — Timer/counter 0 external count input or overflow output.
	4	I	<b>P1.5</b> — Port 1 bit 5 (input only).
		I	<p><b>RST</b> — External Reset input during Power-on or if selected via UCFG1. When functioning as a reset input a LOW on this pin resets the microcontroller, causing I/O ports and peripherals to take on their default states, and the processor begins execution at address 0. <b>When using an oscillator frequency above 12 MHz, the reset input function of P1.5 must be enabled. An external circuit is required to hold the device in reset at power-up until V<sub>DD</sub> has reached its specified level. When system power is removed V<sub>DD</sub> will fall below the minimum specified operating voltage. When using an oscillator frequency above 12 MHz, in some applications, an external brownout detect circuit may be required to hold the device in reset when V<sub>DD</sub> falls below the minimum specified operating voltage.</b> Also used during a power-on sequence to force In-System Programming mode.</p>
P3.0 to P3.1		I/O	<p><b>Port 3:</b> Port 3 is an I/O port with a user-configurable output types. During reset Port 3 latches are configured in the input only mode with the internal pull-up disabled. The operation of port 3 pins as inputs and outputs depends upon the port configuration selected. Each port pin is configured independently. Refer to <a href="#">Section 8.12.1 "Port configurations"</a> and <a href="#">Table 13 "DC electrical characteristics"</a> for details.</p> <p>All pins have Schmitt triggered inputs.</p> <p>Port 3 also provides various special functions as described below:</p>
	3	I/O	<b>P3.0</b> — Port 3 bit 0.
		O	<b>XTAL2</b> — Output from the oscillator amplifier (when a crystal oscillator option is selected via the FLASH configuration).
		O	<b>CLKOUT</b> — CPU clock divided by 2 when enabled via SFR bit (ENCLK to TRIM.6). It can be used if the CPU clock is the internal RC oscillator, Watchdog oscillator or external clock input, except when XTAL1/XTAL2 are used to generate clock source for the real time clock/system timer.
	2	I/O	<b>P3.1</b> — Port 3 bit 1.
		I	<b>XTAL1</b> — Input to the oscillator circuit and internal clock generator circuits (when selected via the FLASH configuration). It can be a port pin if internal RC oscillator or Watchdog oscillator is used as the CPU clock source, <b>and</b> if XTAL1/XTAL2 are not used to generate the clock for the real time clock/system timer.
V <sub>SS</sub>	8	I	<b>Ground:</b> 0 V reference.
V <sub>DD</sub>	1	I	<b>Power Supply:</b> This is the power supply voltage for normal operation as well as Idle and Power-down modes.

Table 4: P89LPC902 pin description

Symbol	Pin	Type	Description
P0.0 to P0.6		I/O	<p><b>Port 0:</b> Port 0 is an I/O port with a user-configurable output type. During reset Port 0 latches are configured in the input only mode with the internal pull-up disabled. The operation of Port 0 pins as inputs and outputs depends upon the port configuration selected. Each port pin is configured independently. Refer to <a href="#">Section 8.12.1 "Port configurations"</a> and <a href="#">Table 13 "DC electrical characteristics"</a> for details.</p> <p>The Keypad Interrupt feature operates with Port 0 pins.</p> <p>All pins have Schmitt triggered inputs.</p> <p>Port 0 also provides various special functions as described below:</p>
	3	I/O	<b>P0.0</b> — Port 0 bit 0.
		I	<b>CMP2</b> — Comparator 2 output.
		I	<b>KB10</b> — Keyboard input 0.
	2	I/O	<b>P0.2</b> — Port 0 bit 2.
		I	<b>CIN2A</b> — Comparator 2 positive input.
		I	<b>KB12</b> — Keyboard input 2.
	7	I/O	<b>P0.4</b> — Port 0 bit 4.
		I	<b>CIN1A</b> — Comparator 1 positive input.
		I	<b>KB14</b> — Keyboard input 4.
	6	I/O	<b>P0.5</b> — Port 0 bit 5.
		I	<b>CMPREF</b> — Comparator reference (negative) input.
		I	<b>KB15</b> — Keyboard input 5.
	5	I/O	<b>P0.6</b> — Port 0 bit 6.
		O	<b>CMP1</b> — Comparator 1 output.
		I	<b>KB16</b> — Keyboard input 6.
P1.0 to P1.5			<p><b>Port 1:</b> Port 1 is an I/O port with a user-configurable output type. During reset Port 1 latches are configured in the input only mode with the internal pull-up disabled. The operation of the configurable Port 1 pins as inputs and outputs depends upon the port configuration selected. Each of the configurable port pins are programmed independently. Refer to <a href="#">Section 8.12.1 "Port configurations"</a> and <a href="#">Table 13 "DC electrical characteristics"</a> for details. P1.5 is input only.</p> <p>All pins have Schmitt triggered inputs.</p> <p>Port 1 also provides various special functions as described below:</p>
	4	I	<b>P1.5</b> — Port 1 bit 5 (input only).
		I	<b>RST</b> — External Reset input during Power-on or if selected via UCFG1. When functioning as a reset input a LOW on this pin resets the microcontroller, causing I/O ports and peripherals to take on their default states, and the processor begins execution at address 0. Also used during a power-on sequence to force In-System Programming mode.
V <sub>SS</sub>	8	I	<b>Ground:</b> 0 V reference.
V <sub>DD</sub>	1	I	<b>Power Supply:</b> This is the power supply voltage for normal operation as well as Idle and Power-down modes.

Table 5: P89LPC903 pin description

Symbol	Pin	Type	Description
P0.0 to P0.6		I/O	<p><b>Port 0:</b> Port 0 is an I/O port with a user-configurable output type. During reset Port 0 latches are configured in the input only mode with the internal pull-up disabled. The operation of Port 0 pins as inputs and outputs depends upon the port configuration selected. Each port pin is configured independently. Refer to <a href="#">Section 8.12.1 “Port configurations”</a> and <a href="#">Table 13 “DC electrical characteristics”</a> for details.</p> <p>The Keypad Interrupt feature operates with Port 0 pins.</p> <p>All pins have Schmitt triggered inputs.</p> <p>Port 0 also provides various special functions as described below:</p>
	2	I/O	<b>P0.2</b> — Port 0 bit 2.
		I	<b>CIN2A</b> — Comparator 2 positive input.
		I	<b>KB12</b> — Keyboard input 2.
	7	I/O	<b>P0.4</b> — Port 0 bit 4.
		I	<b>CIN1A</b> — Comparator 1 positive input.
		I	<b>KB14</b> — Keyboard input 4.
	6	I/O	<b>P0.5</b> — Port 0 bit 5.
		I	<b>CMPREF</b> — Comparator reference (negative) input.
		I	<b>KB15</b> — Keyboard input 5.
P1.0 to P1.5			<p><b>Port 1:</b> Port 1 is an I/O port with a user-configurable output type. During reset Port 1 latches are configured in the input only mode with the internal pull-up disabled. The operation of the configurable Port 1 pins as inputs and outputs depends upon the port configuration selected. Each of the configurable port pins are programmed independently. Refer to <a href="#">Section 8.12.1 “Port configurations”</a> and <a href="#">Table 13 “DC electrical characteristics”</a> for details. P1.5 is input only.</p> <p>All pins have Schmitt triggered inputs.</p> <p>Port 1 also provides various special functions as described below:</p>
	5	I/O	<b>P1.0</b> — Port 1 bit 0.
		O	<b>TxD</b> — Serial port transmitter data.
	3	I/O	<b>P1.1</b> — Port 1 bit 1.
		I	<b>RxD</b> — Serial port receiver data.
	4	I	<b>P1.5</b> — Port 1 bit 5 (input only).
		I	<b>RST</b> — External Reset input during Power-on or if selected via UCFG1. When functioning as a reset input a LOW on this pin resets the microcontroller, causing I/O ports and peripherals to take on their default states, and the processor begins execution at address 0. Also used during a power-on sequence to force In-System Programming mode.
V <sub>SS</sub>	8	I	<b>Ground:</b> 0 V reference.
V <sub>DD</sub>	1	I	<b>Power Supply:</b> This is the power supply voltage for normal operation as well as Idle and Power-down modes.

6. Logic symbols

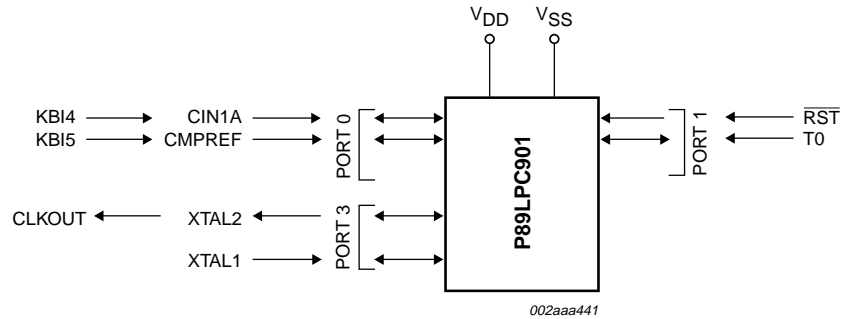

Fig 9. P89LPC901 logic symbol.

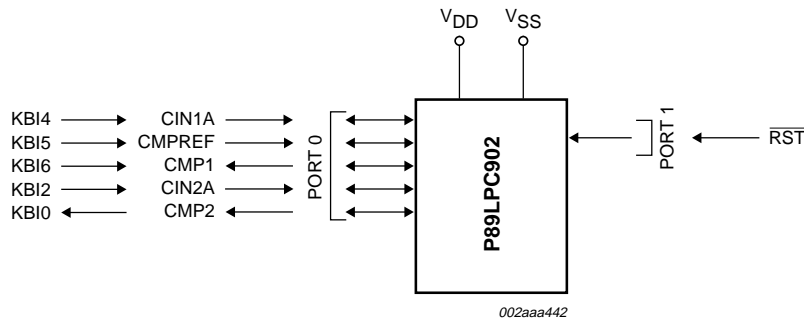

Fig 10. P89LPC902 logic symbol.

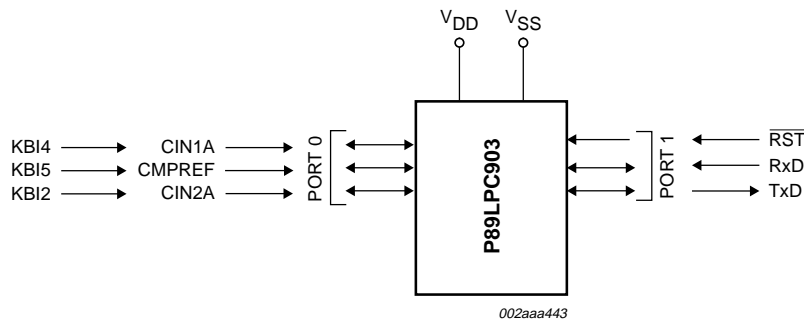

Fig 11. P89LPC903 logic symbol.

Table 6 highlights the differences between these three devices. For a complete list of device features, please see Section 2 “Features” on page 1.

Table 6: Product comparison overview

Type number	External crystal pins	CLKOUT output	T0 PWM output	CMP2 input	CMP1 and CMP2 outputs	UART	
						TxD	RxD
P89LPC901xx	X	X	X	-	-	-	-
P89LPC902xx	-	-	-	X	X	-	-
P89LPC903xx	-	-	-	X	-	X	X

## 7. Special function registers

---

**Remark:** Special Function Registers (SFRs) accesses are restricted in the following ways:

- User must **not** attempt to access any SFR locations not defined.
- Accesses to any defined SFR locations must be strictly for the functions for the SFRs.
- SFR bits labeled '-', '0' or '1' can **only** be written and read as follows:
  - '-' Unless otherwise specified, **must** be written with '0', but can return any value when read (even if it was written with '0'). It is a reserved bit and may be used in future derivatives.
  - '0' **must** be written with '0', and will return a '0' when read.
  - '1' **must** be written with '1', and will return a '1' when read.

**Table 7: P89LPC901 Special function registers**

\* Indicates SFRs that are bit addressable.

Name	Description	SFR addr.	Bit functions and addresses																	
			MSB							LSB										
			Bit address	E7	E6	E5	E4	E3	E2	E1	E0	F7	F6	F5	F4	F3	F2	F1	F0	
ACC*	Accumulator	E0H																		
AUXR1	Auxiliary function register	A2H		CLKLP	-	-	ENT0	SRST	0	-	DPS									
B*	B register	F0H	Bit address																	
CMP1	Comparator 1 control register	ACH		-	-	CE1	-	CN1	-	CO1	CMF1									
DIVM	CPU clock divide-by-M control	95H																		
DPTR	Data pointer (2 bytes)																			
DPH	Data pointer high	83H																		
DPL	Data pointer low	82H																		
FMADRH	Program Flash address high	E7H																		
FMADRL	Program Flash address low	E6H																		
FMCON	Program Flash Control (Read)	E4H		BUSY	-	-	-	HVA	HVE	SV	OI									
FMDATA	Program Flash data	E5H																		
IEN0*	Interrupt enable 0	A8H		EA	EWDRT	EBO	-	ET1	-	ET0	-									
IEN1*	Interrupt enable 1	E8H	Bit address	EF	EE	ED	EC	EB	EA	E9	E8									
IP0*	Interrupt priority 0	B8H	Bit address	BF	BE	BD	BC	BB	BA	B9	B8									
IP0H	Interrupt priority 0 high	B7H		-	PWDRT	PBO	-	PT1	-	PT0	-									
				-	PWDRT H	PBOH	-	PT1H	-	PT0H	-									
IP1*	Interrupt priority 1	F8H	Bit address	FF	FE	FD	FC	FB	FA	F9	F8									
IP1H	Interrupt priority 1 high	F7H		-	-	-	-	-	PC	PKBI	-									
KBCON	Keypad control register	94H		-	-	-	-	-	-	PATN	KBIF									
										_SEL										



**Table 7: P89LPC901 Special function registers...***continued*  
*\* indicates SFRs that are bit addressable.*

Name	Description	SFR addr.	Bit functions and addresses								
			MSB				LSB				
			<b>Bit address</b>	<b>8F</b>	<b>8E</b>	<b>8D</b>	<b>8C</b>	<b>8B</b>	<b>8A</b>	<b>89</b>	<b>88</b>
TCON*	Timer 0 and 1 control	88H		TF1	TR1	TF0	TR0	-	-	-	-
TH0	Timer 0 high	8CH									
TH1	Timer 1 high	8DH									
TL0	Timer 0 low	8AH									
TL1	Timer 1 low	8BH									
TMOD	Timer 0 and 1 mode	89H	-	-	T1M1	T1M0	-	-	T0M1	T0M0	
TRIM	Internal oscillator trim register	96H	-	-	TRIM.5	TRIM.4	TRIM.3	TRIM.2	TRIM.1	TRIM.0	
WDCON	Watchdog control register	A7H	PRE2	PRE1	PRE0	-	-	WDRUN	WDTOF	WDCLK	
WDL	Watchdog load	C1H									
WFEED1	Watchdog feed 1	C2H									
WFEED2	Watchdog feed 2	C3H									

[1] All ports are in input only (high impedance) state after power-up.

[2] BRGR1 and BRGR0 must only be written if BRGEN in BRGCON SFR is '0'. If any are written while BRGEN = 1, the result is unpredictable. Unimplemented bits in SFRs (labeled '-') are X (unknown) at all times. Unless otherwise specified, ones should not be written to these bits since they may purposes in future derivatives. The reset values shown for these bits are '0's although they are unknown when read.

[3] The RSTSRC register reflects the cause of the P89LPC901/902/903 reset. Upon a power-up reset, all reset source flags are cleared except POF and BO value is xx110000.

[4] After reset, the value is 111001x1, i.e., PRE2-PRE0 are all '1', WDRUN = 1 and WDCLK = 1. WDTOF bit is '1' after Watchdog reset and is '0' after power-on not affect WDTOF.

[5] On power-on reset, the TRIM SFR is initialized with a factory preprogrammed value. Other resets will not cause initialization of the TRIM register.

[6] The only reset source that affects these SFRs is power-on reset.

**Table 8: P89LPC902 Special function registers**

\* Indicates SFRs that are bit addressable.

Name	Description	SFR addr.	Bit functions and addresses															
			MSB								LSB							
		Bit address	E7	E6	E5	E4	E3	E2	E1	E0	F7	F6	F5	F4	F3	F2	F1	F0
ACC*	Accumulator	E0H																
AUXR1	Auxiliary function register	A2H	-	-	-	-	SRST	0	-	DPS								
B*	B register	F0H																
CMP1	Comparator 1 control register	ACH	-	-	CE1	-	CN1	OE1	CO1	CMF1								
CMP2	Comparator 2 control register	ADH	-	-	CE2	-	CN2	OE2	CO2	CMF2								
DIVM	CPU clock divide-by-M control	95H																
DPTR	Data pointer (2 bytes)																	
DPH	Data pointer high	83H																
DPL	Data pointer low	82H																
FMADRH	Program Flash address high	E7H																
FMADRL	Program Flash address low	E6H																
FMCON	Program Flash Control (Read)	E4H	BUSY	-	-	-	HVA	HVE	SV	OI								
FMDATA	Program Flash data	E5H																
IEN0*	Interrupt enable 0	A8H	EA	EWDRT	EBO	-	ET1	-	ET0	-	FMCMD. 7	FMCMD. 6	FMCMD. 5	FMCMD. 4	FMCMD. 3	FMCMD. 2	FMCMD. 1	FMCMD. 0
IEN1*	Interrupt enable 1	E8H	EF	EE	ED	EC	EB	EA	E9	E8								
IP0*	Interrupt priority 0	B8H	BF	BE	BD	BC	BB	BA	B9	B8								
IP0H	Interrupt priority 0 high	B7H	-	PWDRT	PBO	-	PT1	-	PT0	-								
			-	PWDRT <sub>H</sub>	PBOH	-	PT1H	-	PT0H	-								
IP1*	Interrupt priority 1	F8H	FF	FE	FD	FC	FB	FA	F9	F8								
IP1H	Interrupt priority 1 high	F7H	-	-	-	-	-	PC	PKBI	-								
			-	-	-	-	-	PCH	PKBIH	-								

**Table 8: P89LPC902 Special function registers...***continued*  
*\* indicates SFRs that are bit addressable.*

Name	Description	SFR addr.	Bit functions and addresses																		
			MSB								LSB										
KBCON	Keypad control register	94H	-	-	-	-	-	-	-	-	-	-	-	-	-	-	-	PATN_SEL	KBIF	KBIF	LSB
KBMASK	Keypad interrupt mask register	86H																			
KBPATN	Keypad pattern register	93H																			
		<b>Bit address</b>	<b>87</b>	<b>86</b>	<b>85</b>	<b>84</b>	<b>83</b>	<b>82</b>	<b>81</b>	<b>80</b>											
P0*	Port 0	80H	-	CMP1 /KB6	CMPREF /KB5	CIN1A /KB4	-	KB2	-	KB0	-	-	-	-	-	-	-	-	-	-	-
		<b>Bit address</b>	<b>97</b>	<b>96</b>	<b>95</b>	<b>94</b>	<b>93</b>	<b>92</b>	<b>91</b>	<b>90</b>											
P1*	Port 1	90H	-	-	RST	-	-	-	-	-	-	-	-	-	-	-	-	-	-	-	-
		<b>Bit address</b>	<b>B7</b>	<b>B6</b>	<b>B5</b>	<b>B4</b>	<b>B3</b>	<b>B2</b>	<b>B1</b>	<b>B0</b>											
P0M1	Port 0 output mode 1	84H	-	(P0M1.6)	(P0M1.5)	(P0M1.4)	-	(P0M1.2)	-	(P0M1.0)	-	-	-	-	-	-	-	-	-	-	-
P0M2	Port 0 output mode 2	85H	-	(P0M2.6)	(P0M2.5)	(P0M2.4)	-	(P0M2.2)	-	(P0M2.0)	-	-	-	-	-	-	-	-	-	-	-
P1M1	Port 1 output mode 1	91H	-	-	(P1M1.5)	-	-	-	-	-	-	-	-	-	-	-	-	-	-	-	-
P1M2	Port 1 output mode 2	92H	-	-	(P1M2.5)	-	-	-	-	-	-	-	-	-	-	-	-	-	-	-	-
PCON	Power control register	87H	-	-	BOPD	BOI	GF1	GF0	PMOD1	PMOD0											
PCONA	Power control register A	B5H	RTCPD		VCPD																
PCONB	reserved for Power Control Register B	B6H	-	-	-	-	-	-	-	-	-	-	-	-	-	-	-	-	-	-	-
		<b>Bit address</b>	<b>D7</b>	<b>D6</b>	<b>D5</b>	<b>D4</b>	<b>D3</b>	<b>D2</b>	<b>D1</b>	<b>D0</b>											
PSW*	Program status word	D0H	CY	AC	F0	RS1	RS0	OV	F1	P											
PT0AD	Port 0 digital input disable	F6H	-	-	PT0AD.5	PT0AD.4	-	PT0AD.2	-	-	-	-	-	-	-	-	-	-	-	-	-
RSTSRC	Reset source register	DFH	-	-	BOF	POF	-	R_WD	R_SF	R_EX											
RTCCON	Real-time clock control	D1H	RTCF	RTCS1	RTCS0	-	-	-	ERTC	RTCEN											
RTCH	Real-time clock register high	D2H																			
RTCL	Real-time clock register low	D3H																			
SP	Stack pointer	81H																			

**Table 8: P89LPC902 Special function registers...***continued*  
*\* indicates SFRs that are bit addressable.*

Name	Description	SFR addr.	Bit functions and addresses									
			MSB					LSB				
			<b>Bit address</b>	<b>8F</b>	<b>8E</b>	<b>8D</b>	<b>8C</b>	<b>8B</b>	<b>8A</b>	<b>89</b>	<b>88</b>	
TCON*	Timer 0 and 1 control	88H		TF1	TR1	TF0	TR0	-	-	-	-	
TH0	Timer 0 high	8CH										
TH1	Timer 1 high	8DH										
TL0	Timer 0 low	8AH										
TL1	Timer 1 low	8BH										
TMOD	Timer 0 and 1 mode	89H	-	-	T1M1	T1M0	-	-	T0M1	T0M0		
TRIM	Internal oscillator trim register	96H	-	-	TRIM.5	TRIM.4	TRIM.3	TRIM.2	TRIM.1	TRIM.0		
WDCON	Watchdog control register	A7H	PRE2	PRE1	PRE0	-	-	WDRUN	WDTOF	WDCLK		
WDL	Watchdog load	C1H										
WFEED1	Watchdog feed 1	C2H										
WFEED2	Watchdog feed 2	C3H										

[1] All ports are in input only (high impedance) state after power-up.

[2] BRGR1 and BRGR0 must only be written if BRGEN in BRGCON SFR is '0'. If any are written while BRGEN = 1, the result is unpredictable. Unimplemented bits in SFRs (labeled '-') are X (unknown) at all times. Unless otherwise specified, ones should not be written to these bits since they may purposes in future derivatives. The reset values shown for these bits are '0's although they are unknown when read.

[3] The RSTSRC register reflects the cause of the P89LPC901/902/903 reset. Upon a power-up reset, all reset source flags are cleared except POF and BO value is xx110000.

[4] After reset, the value is 111001x1, i.e., PRE2-PRE0 are all '1', WDRUN = 1 and WDCLK = 1. WDTOF bit is '1' after Watchdog reset and is '0' after power-on not affect WDTOF.

[5] On power-on reset, the TRIM SFR is initialized with a factory preprogrammed value. Other resets will not cause initialization of the TRIM register.

[6] The only reset source that affects these SFRs is power-on reset.

**Table 9: P89LPC903 Special function registers**

\* Indicates SFRs that are bit addressable.

Name	Description	SFR addr.	Bit functions and addresses															
			MSB															
			Bit address	E7	E6	E5	E4	E3	E2	E1	E0					LSB		
ACC*	Accumulator	E0H																
AUXR1	Auxiliary function register	A2H			EBRR	-	-	SRST	0	-							DPS	
B*	B register	F0H	Bit address	F7	F6	F5	F4	F3	F2	F1	F0					F0		
BRGR0 <sup>[2]</sup>	Baud rate generator rate low	BEH																
BRGR1 <sup>[2]</sup>	Baud rate generator rate high	BFH																
BRGCON	Baud rate generator control	BDH													SBRGS	BRGEN		
CMP1	Comparator 1 control register	ACH				CE1	-	CN1	-	CO1	CMF1					CMF1		
CMP2	Comparator 2 control register	ADH				CE2	-	CN2	-	CO2	CMF2					CMF2		
DIVM	CPU clock divide-by-M control	95H																
DPTR	Data pointer (2 bytes)																	
DPH	Data pointer high	83H																
DPL	Data pointer low	82H																
FMADRH	Program Flash address high	E7H																
FMADRL	Program Flash address low	E6H																
FMCON	Program Flash Control (Read)	E4H		BUSY	-	-	-	HVA	HVE	SV	OI						OI	
	Program Flash Control (Write)																	
FMDATA	Program Flash data	E5H																
IEN0*	Interrupt enable 0	A8H	Bit address	EA	EWDRT	EBO	ES/ESR	ET1	-	ET0	-							
IEN1*	Interrupt enable 1	E8H	Bit address	EF	EE	ED	EC	EB	EA	E9	E8							
IP0*	Interrupt priority 0	B8H	Bit address	BF	BE	BD	BC	BB	BA	B9	B8							
IPOH	Interrupt priority 0 high	B7H		-	PWDRT	PBO	PS/PSR	PT1	-	PT0	-							
				-	PWDRT H	PBOH	PSH /PSRH	PT1H	-	PT0H	-							
			Bit address	FF	FE	FD	FC	FB	FA	F9	F8							

**Table 9: P89LPC903 Special function registers...***continued*  
*\* indicates SFRs that are bit addressable.*

Name	Description	SFR addr.	Bit functions and addresses																		
			MSB															LSB			
IP1*	Interrupt priority 1	F8H	-	PST	-	-	-	-	-	-	-	-	-	-	-	-	-	PC	PKBI	-	
IP1H	Interrupt priority 1 high	F7H	-	PSTH	-	-	-	-	-	-	-	-	-	-	-	-	-	PCH	PKBIH	-	
KBCON	Keypad control register	94H	-	-	-	-	-	-	-	-	-	-	-	-	-	-	-	-	PATN	KBIF	-
KBMASK	Keypad interrupt mask register	86H																			
KBPATN	Keypad pattern register	93H																			
			<b>87</b>	<b>86</b>	<b>85</b>	<b>84</b>	<b>83</b>	<b>82</b>	<b>81</b>	<b>80</b>											
P0*	Port 0	80H	-	-	CMPREF /KB5	CIN1A /KB4	-	KB2	-	-	-	-	-	-	-	-	-	-	-	-	
			<b>97</b>	<b>96</b>	<b>95</b>	<b>94</b>	<b>93</b>	<b>92</b>	<b>91</b>	<b>90</b>											
P1*	Port 1	90H	-	-	RST	-	-	-	RxD	TxD											
P0M1	Port 0 output mode 1	84H	-	-	(P0M1.5)	(P0M1.4)	-	(P0M1.2)	-	-											
P0M2	Port 0 output mode 2	85H	-	-	(P0M2.5)	(P0M2.4)	-	(P0M2.2)	-	-											
P1M1	Port 1 output mode 1	91H	-	-	(P1M1.5)	-	-	-	(P1M1.1)	(P1M1.0)											
P1M2	Port 1 output mode 2	92H	-	-	(P1M2.5)	-	-	-	(P1M2.1)	(P1M2.0)											
PCON	Power control register	87H	SMOD1	SMOD0	BOPD	BOI	GF1	GF0	PMOD1	PMOD0											
PCONA	Power control register A	B5H	RTCPD	VCPD																	
PCONB	reserved for Power Control Register B	B6H	-	-	-	-	-	-	-	-											
			<b>D7</b>	<b>D6</b>	<b>D5</b>	<b>D4</b>	<b>D3</b>	<b>D2</b>	<b>D1</b>	<b>D0</b>											
PSW*	Program status word	D0H	CY	AC	F0	RS1	RS0	OV	F1	P											
PT0AD	Port 0 digital input disable	F6H	-	-	PT0AD.5	PT0AD.4	-	PT0AD.2	-	-											
RSTSRC	Reset source register	DFH	-	-	BOF	POF	R_BK	R_WD	R_SF	R_EX											
RTCCON	Real-time clock control	D1H	RTCF	RTCS1	RTCS0	-	-	-	ERTC	RTCEN											
RTCH	Real-time clock register high	D2H																			
RTCL	Real-time clock register low	D3H																			
SADDR	Serial port address register	A9H																			
SADEN	Serial port address enable	B9H																			



## 8. Functional description

**Remark:** Please refer to the *P89LPC901/902/903 User's Manual* for a more detailed functional description.

### 8.1 Enhanced CPU

The P89LPC901/902/903 uses an enhanced 80C51 CPU which runs at 6 times the speed of standard 80C51 devices. A machine cycle consists of two CPU clock cycles, and most instructions execute in one or two machine cycles.

### 8.2 Clocks

#### 8.2.1 Clock definitions

The P89LPC901/902/903 device has several internal clocks as defined below:

**OSCCLK** — Input to the DIVM clock divider. OSCCLK is selected from one of the clock sources (see [Figure 12](#), [13](#), and [14](#)) and can also be optionally divided to a slower frequency (see [Section 8.7 "CPU CLOCK \(CCLK\) modification: DIVM register"](#)).

**Note:**  $f_{osc}$  is defined as the OSCCLK frequency.

**CCLK** — CPU clock; output of the clock divider. There are two CCLK cycles per machine cycle, and most instructions are executed in one to two machine cycles (two or four CCLK cycles).

**RCCLK** — The internal 7.373 MHz RC oscillator output.

**PCLK** — Clock for the various peripheral devices and is CCLK/2

#### 8.2.2 CPU clock (OSCCLK)

The P89LPC901/902/903 provides several user-selectable oscillator options in generating the CPU clock. This allows optimization for a range of needs from high precision to lowest possible cost. These options are configured when the FLASH is programmed and include an on-chip Watchdog oscillator and an on-chip RC oscillator.

The P89LPC901, in addition, includes an option for an oscillator using an external crystal or an external clock source. The crystal oscillator can be optimized for low, medium, or high frequency crystals covering a range from 20 kHz to 12 MHz.

#### 8.2.3 Low speed oscillator option (P89LPC901)

This option supports an external crystal in the range of 20 kHz to 100 kHz. Ceramic resonators are also supported in this configuration.

#### 8.2.4 Medium speed oscillator option (P89LPC901)

This option supports an external crystal in the range of 100 kHz to 4 MHz. Ceramic resonators are also supported in this configuration.

### 8.2.5 High speed oscillator option (P89LPC901)

This option supports an external crystal in the range of 4 MHz to 18 MHz. Ceramic resonators are also supported in this configuration. **When using an oscillator frequency above 12 MHz, the reset input function of P1.5 must be enabled. An external circuit is required to hold the device in reset at power-up until  $V_{DD}$  has reached its specified level. When system power is removed  $V_{DD}$  will fall below the minimum specified operating voltage. When using an oscillator frequency above 12 MHz, in some applications, an external brownout detect circuit may be required to hold the device in reset when  $V_{DD}$  falls below the minimum specified operating voltage.** If CCLK is 8 MHz or slower, the CLKLP SFR bit (AUXR1.7) can be set to '1' to reduce power consumption. On reset, CLKLP is '0' allowing highest performance access. This bit can then be set in software if CCLK is running at 8 MHz or slower.

### 8.2.6 Clock output (P89LPC901)

The P89LPC901 supports a user selectable clock output function on the XTAL2/CLKOUT pin when crystal oscillator is not being used. This condition occurs if another clock source has been selected (on-chip RC oscillator, Watchdog oscillator, external clock input on X1) and if the Real-Time clock is not using the crystal oscillator as its clock source. This allows external devices to synchronize to the P89LPC901. This output is enabled by the ENCLK bit in the TRIM register. The frequency of this clock output is  $\frac{1}{2}$  that of the CCLK. If the clock output is not needed in Idle mode, it may be turned off prior to entering Idle, saving additional power.

## 8.3 On-chip RC oscillator option

The P89LPC901/902/903 has a 6-bit TRIM register that can be used to tune the frequency of the RC oscillator. During reset, the TRIM value is initialized to a factory pre-programmed value to adjust the oscillator frequency to 7.373 MHz,  $\pm 2.5\%$ . End-user applications can write to the Trim register to adjust the on-chip RC oscillator to other frequencies. If CCLK is 8 MHz or slower, the CLKLP SFR bit (AUXR1.7) can be set to '1' to reduce power consumption. On reset, CLKLP is '0' allowing highest performance access. This bit can then be set in software if CCLK is running at 8 MHz or slower.

## 8.4 Watchdog oscillator option

The Watchdog has a separate oscillator which has a frequency of 400 kHz. This oscillator can be used to save power when a high clock frequency is not needed.

## 8.5 External clock input option (P89LPC901)

In this configuration, the processor clock is derived from an external source driving the XTAL1/P3.1 pin. The rate may be from 0 Hz up to 18 MHz. The XTAL2/P3.0 pin may be used as a standard port pin or a clock output. **When using an oscillator frequency above 12 MHz, the reset input function of P1.5 must be enabled. An external circuit is required to hold the device in reset at power-up until  $V_{DD}$  has reached its specified level. When system power is removed  $V_{DD}$  will fall below the minimum specified operating voltage. When using an oscillator frequency above 12 MHz, in some applications, an external brownout detect circuit may be required to hold the device in reset when  $V_{DD}$  falls below the minimum specified operating voltage.**

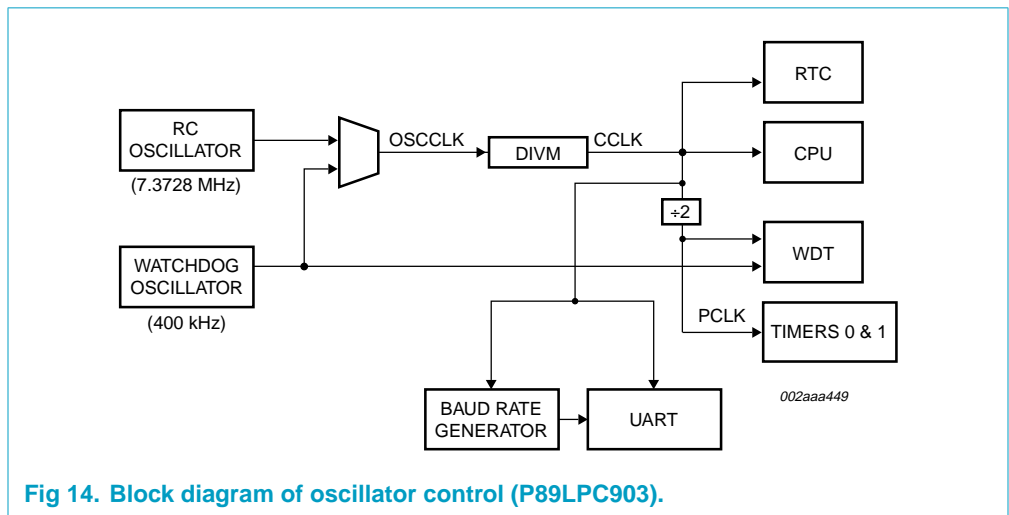
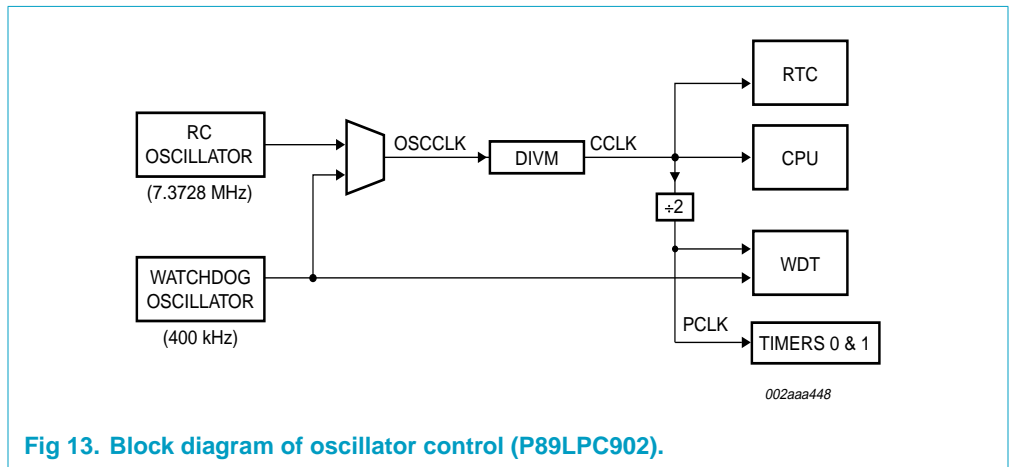
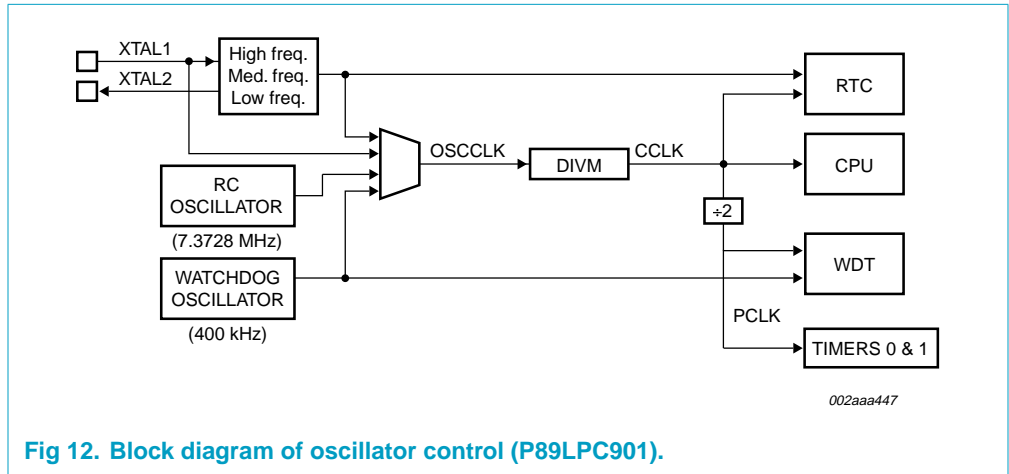

## 8.6 CPU CLock (CCLK) wake-up delay

The P89LPC901/902/903 has an internal wake-up timer that delays the clock until it stabilizes depending to the clock source used. If the clock source is any of the three crystal selections (P89LPC901) the delay is 992 OSCCLK cycles plus 60 to 100  $\mu$ s.

## 8.7 CPU CLOCK (CCLK) modification: DIVM register

The OSCCLK frequency can be divided down up to 510 times by configuring a dividing register, DIVM, to generate CCLK. This feature makes it possible to temporarily run the CPU at a lower rate, reducing power consumption. By dividing the clock, the CPU can retain the ability to respond to events that would not exit Idle mode by executing its normal program at a lower rate. This can also allow bypassing the oscillator start-up time in cases where Power-down mode would otherwise be used. The value of DIVM may be changed by the program at any time without interrupting code execution.

## 8.8 Low power select

The P89LPC901 is designed to run at 18 MHz (CCLK) maximum. However, if CCLK is 8 MHz or slower, the CLKLP SFR bit (AUXR1.7) can be set to '1' to lower the power consumption further. On any reset, CLKLP is '0' allowing highest performance access. This bit can then be set in software if CCLK is running at 8 MHz or slower.

## 8.9 Memory organization

The various P89LPC901/902/903 memory spaces are as follows:

- DATA  
128 bytes of internal data memory space (00h:7Fh) accessed via direct or indirect addressing, using instruction other than MOVX and MOVC. All or part of the Stack may be in this area.
- SFR  
Special Function Registers. Selected CPU registers and peripheral control and status registers, accessible only via direct addressing.
- CODE  
64 kB of Code memory space, accessed as part of program execution and via the MOVC instruction. The P89LPC901/902/903 has 1 kB of on-chip Code memory.

## 8.10 Data RAM arrangement

The 128 bytes of on-chip RAM is organized as follows:

**Table 10: On-chip data memory usages**

Type	Data RAM	Size (Bytes)
DATA	Memory that can be addressed directly and indirectly	128

## 8.11 Interrupts

The P89LPC901/902/903 uses a four priority level interrupt structure. This allows great flexibility in controlling the handling of the many interrupt sources.

The P89LPC901 supports 6 interrupt sources: timers 0 and 1, brownout detect, Watchdog/real-time clock, keyboard, and the comparator.

The P89LPC902 supports 6 interrupt sources: timers 0 and 1, brownout detect, Watchdog/real-time clock, keyboard, and comparators 1 and 2.

The P89LPC903 supports 9 interrupt sources: timers 0 and 1, serial port Tx, serial port Rx, combined serial port Rx/Tx, brownout detect, Watchdog/real-time clock, keyboard, and comparators 1 and 2.

Each interrupt source can be individually enabled or disabled by setting or clearing a bit in the interrupt enable registers IEN0 or IEN1. The IEN0 register also contains a global disable bit, EA, which disables all interrupts.

Each interrupt source can be individually programmed to one of four priority levels by setting or clearing bits in the interrupt priority registers IP0, IP0H, IP1, and IP1H. An interrupt service routine in progress can be interrupted by a higher priority interrupt, but not by another interrupt of the same or lower priority. The highest priority interrupt service cannot be interrupted by any other interrupt source. If two requests of different priority levels are pending at the start of an instruction, the request of higher priority level is serviced.

If requests of the same priority level are pending at the start of an instruction, an internal polling sequence determines which request is serviced. This is called the arbitration ranking. Note that the arbitration ranking is only used to resolve pending requests of the same priority level.

#### 8.11.1 External interrupt inputs

The P89LPC901/902/903 has a Keypad Interrupt function. This can be used as an external interrupt input.

If enabled when the P89LPC901/902/903 is put into Power-down or Idle mode, the interrupt will cause the processor to wake-up and resume operation. Refer to [Section 8.14 "Power reduction modes"](#) for details.

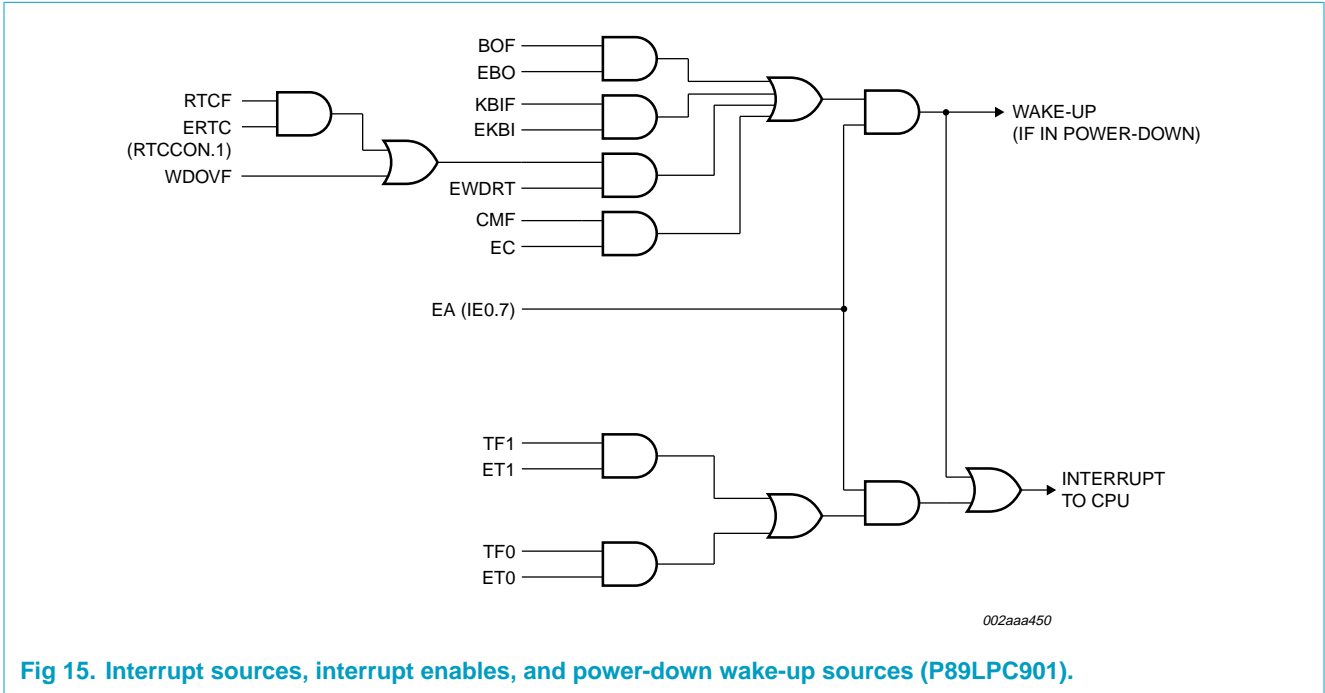

Fig 15. Interrupt sources, interrupt enables, and power-down wake-up sources (P89LPC901).

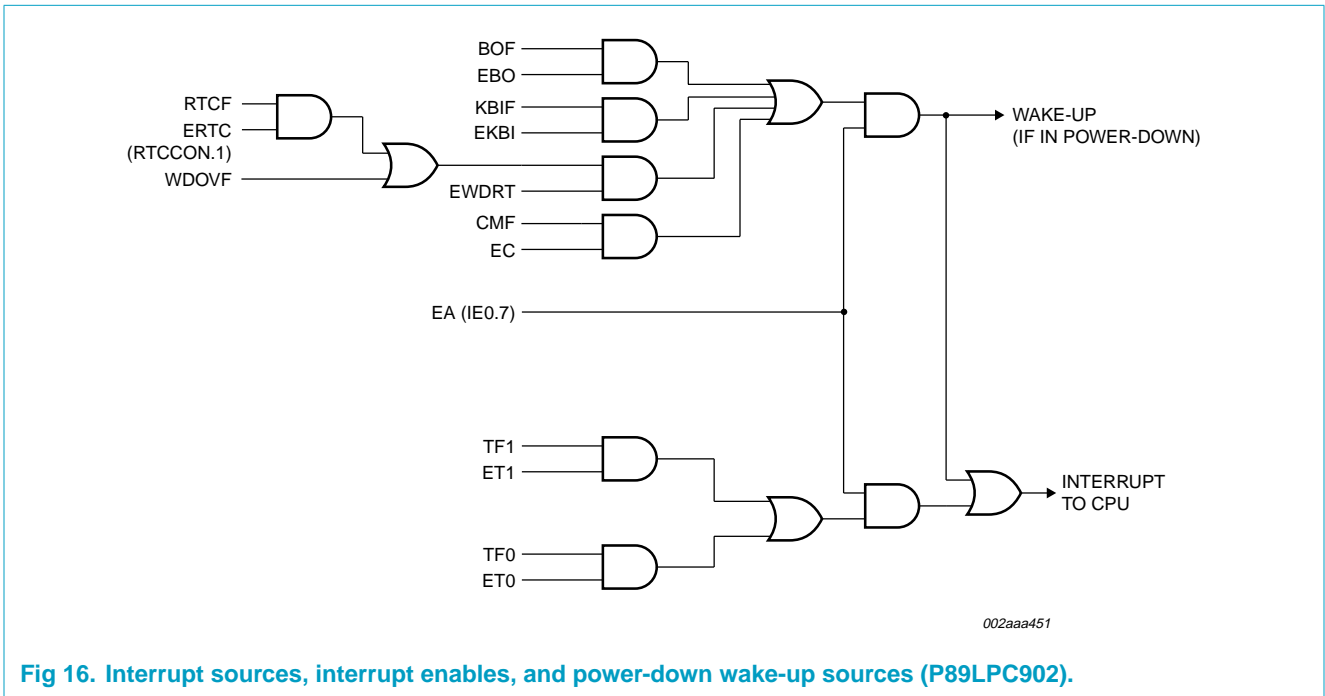

Fig 16. Interrupt sources, interrupt enables, and power-down wake-up sources (P89LPC902).

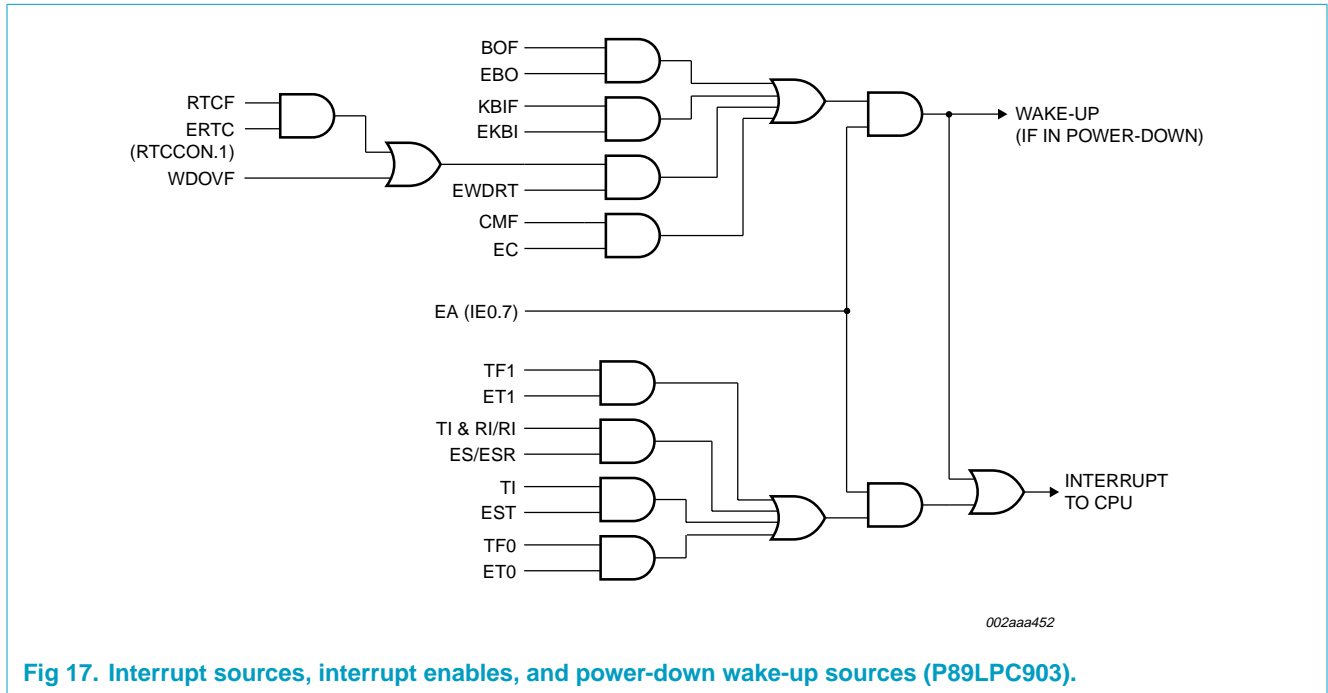

Fig 17. Interrupt sources, interrupt enables, and power-down wake-up sources (P89LPC903).

### 8.12 I/O ports

The P89LPC901 has between 3 and 6 I/O pins: P0.4, P0.5, P1.2, P1.5, P3.0, and P3.1 The exact number of I/O pins available depends on the clock and reset options chosen, as shown in Table 11.

Table 11: Number of I/O pins available

Clock source	Reset option	Number of I/O pins (8-pin package)
On-chip oscillator or Watchdog oscillator	No external reset (except during power-up)	6
	External $\overline{\text{RST}}$ pin supported	5
External clock input	No external reset (except during power-up)	5
	External $\overline{\text{RST}}$ pin supported <sup>[1]</sup>	4
Low/medium/high speed oscillator (external crystal or resonator)	No external reset (except during power-up)	4
	External $\overline{\text{RST}}$ pin supported <sup>[1]</sup>	3

[1] Required for operation above 12 MHz.

The P89LPC902 and P89LPC903 devices have either 5 or 6 I/O pins depending on the reset pin option chosen.

#### 8.12.1 Port configurations

All but one I/O port pin on the P89LPC901/902/903 may be configured by software to one of four types on a bit-by-bit basis. These are: quasi-bidirectional (standard 80C51 port outputs), push-pull, open drain, and input-only. Two configuration registers for each port select the output type for each port pin.

P1.5 ( $\overline{\text{RST}}$ ) can only be an input and cannot be configured.

### 8.12.2 Quasi-bidirectional output configuration

Quasi-bidirectional output type can be used as both an input and output without the need to reconfigure the port. This is possible because when the port outputs a logic HIGH, it is weakly driven, allowing an external device to pull the pin LOW. When the pin is driven LOW, it is driven strongly and able to sink a fairly large current. These features are somewhat similar to an open-drain output except that there are three pull-up transistors in the quasi-bidirectional output that serve different purposes.

The P89LPC901/902/903 is a 3 V device, however, the pins are 5 V-tolerant (except for XTAL1 and XTAL2). In quasi-bidirectional mode, if a user applies 5 V on the pin, there will be a current flowing from the pin to  $V_{DD}$ , causing extra power consumption. Therefore, applying 5 V in quasi-bidirectional mode is discouraged.

A quasi-bidirectional port pin has a Schmitt-triggered input that also has a glitch suppression circuit.

### 8.12.3 Open-drain output configuration

The open-drain output configuration turns off all pull-ups and only drives the pull-down transistor of the port driver when the port latch contains a logic '0'. To be used as a logic output, a port configured in this manner must have an external pull-up, typically a resistor tied to  $V_{DD}$ .

An open-drain port pin has a Schmitt-triggered input that also has a glitch suppression circuit.

### 8.12.4 Input-only configuration

The input-only port configuration has no output drivers. It is a Schmitt-triggered input that also has a glitch suppression circuit.

### 8.12.5 Push-pull output configuration

The push-pull output configuration has the same pull-down structure as both the open-drain and the quasi-bidirectional output modes, but provides a continuous strong pull-up when the port latch contains a logic '1'. The push-pull mode may be used when more source current is needed from a port output. A push-pull port pin has a Schmitt-triggered input that also has a glitch suppression circuit.

### 8.12.6 Port 0 analog functions

The P89LPC901/902/903 incorporates an Analog Comparator. In order to give the best analog function performance and to minimize power consumption, pins that are being used for analog functions must have the digital outputs and digital inputs disabled.

Digital outputs are disabled by putting the port output into the Input-Only (high impedance) mode as described in [Section 8.12.4 "Input-only configuration"](#).

Digital inputs on Port 0 may be disabled through the use of the PT0AD register. On any reset, the PT0AD bits default to '0's to enable digital functions.

### 8.12.7 Additional port features

After power-up, all pins are in Input-Only mode. **Please note that this is different from the LPC76x series of devices.**

- After power-up all I/O pins, except P1.5, may be configured by software.
- Pin P1.5 is input only.

Every output on the P89LPC901/902/903 has been designed to sink typical LED drive current. However, there is a maximum total output current for all ports which must not be exceeded. Please refer to [Table 13 “DC electrical characteristics”](#) for detailed specifications.

All ports pins that can function as an output have slew rate controlled outputs to limit noise generated by quickly switching output signals. The slew rate is factory-set to approximately 10 ns rise and fall times.

## 8.13 Power monitoring functions

The P89LPC901/902/903 incorporates power monitoring functions designed to prevent incorrect operation during initial power-up and power loss or reduction during operation. This is accomplished with two hardware functions: Power-on Detect and Brownout detect.

### 8.13.1 Brownout detection

The Brownout detect function determines if the power supply voltage drops below a certain level. The default operation is for a Brownout detection to cause a processor reset, however, it may alternatively be configured to generate an interrupt.

Brownout detection may be enabled or disabled in software.

If Brownout detection is enabled, the operating voltage range for  $V_{DD}$  is 2.7 V to 3.6 V, and the brownout condition occurs when  $V_{DD}$  falls below the brownout trip voltage,  $V_{BO}$  (see [Table 13 “DC electrical characteristics”](#)), and is negated when  $V_{DD}$  rises above  $V_{BO}$ . If brownout detection is disabled, the operating voltage range for  $V_{DD}$  is 2.4 V to 3.6 V. If the P89LPC901/902/903 device is to operate with a power supply that can be below 2.7 V, BOE should be left in the unprogrammed state so that the device can operate at 2.4 V, otherwise continuous brownout reset may prevent the device from operating.

For correct activation of Brownout detect, the  $V_{DD}$  rise and fall times must be observed. Please see [Table 13 “DC electrical characteristics”](#) for specifications.

### 8.13.2 Power-on detection

The Power-on Detect has a function similar to the Brownout detect, but is designed to work as power comes up initially, before the power supply voltage reaches a level where Brownout detect can work. The POF flag in the RSTSRC register is set to indicate an initial power-up condition. The POF flag will remain set until cleared by software.

## 8.14 Power reduction modes

The P89LPC901/902/903 supports three different power reduction modes. These modes are Idle mode, Power-down mode, and total Power-down mode.

#### 8.14.1 Idle mode

Idle mode leaves peripherals running in order to allow them to activate the processor when an interrupt is generated. Any enabled interrupt source or reset may terminate Idle mode.

#### 8.14.2 Power-down mode

The Power-down mode stops the oscillator in order to minimize power consumption. The P89LPC901/902/903 exits Power-down mode via any reset, or certain interrupts. In Power-down mode, the power supply voltage may be reduced to the RAM keep-alive voltage  $V_{RAM}$ . This retains the RAM contents at the point where Power-down mode was entered. SFR contents are not guaranteed after  $V_{DD}$  has been lowered to  $V_{RAM}$ , therefore it is highly recommended to wake up the processor via reset in this case.  $V_{DD}$  must be raised to within the operating range before the Power-down mode is exited.

Some chip functions continue to operate and draw power during Power-down mode, increasing the total power used during Power-down. These include: Brownout detect, Watchdog Timer, Comparators (note that Comparators can be powered-down separately), and Real-Time Clock (RTC)/System Timer. The internal RC oscillator is disabled unless both the RC oscillator has been selected as the system clock **and** the RTC is enabled.

#### 8.14.3 Total Power-down mode

This is the same as Power-down mode except that the brownout detection circuitry and the voltage comparators are also disabled to conserve additional power. The internal RC oscillator is disabled unless both the RC oscillator has been selected as the system clock **and** the RTC is enabled. If the internal RC oscillator is used to clock the RTC during Power-down, there will be high power consumption. Please use an external low frequency clock to achieve low power with the Real-Time Clock running during Power-down.

### 8.15 Reset

The P1.5/ $\overline{RST}$  pin can function as either an active-LOW reset input or as a digital input, P1.5. The RPE (Reset Pin Enable) bit in UCFG1, when set to '1', enables the external reset input function on P1.5. When cleared, P1.5 may be used as an input pin.

**Remark:** During a power-up sequence, the RPE selection is overridden and this pin will always function as a reset input. **An external circuit connected to this pin should not hold this pin LOW during a power-on sequence as this will keep the device in reset.** After power-up this input will function either as an external reset input or as a digital input as defined by the RPE bit. Only a power-up reset will temporarily override the selection defined by RPE bit. Other sources of reset will not override the RPE bit.

**Remark:** During a power cycle,  $V_{DD}$  must fall below  $V_{POR}$  (see Table 13 "DC electrical characteristics") before power is reapplied, in order to ensure a power-on reset.

Reset can be triggered from the following sources:

- External reset pin (during power-up or if user configured via UCFG1. This option must be used for an oscillator frequency above 12 MHz.)
- Power-on detect
- Brownout detect
- Watchdog Timer
- Software reset
- UART break character detect reset (P80LPC903).

For every reset source, there is a flag in the Reset Register, RSTSRC. The user can read this register to determine the most recent reset source. These flag bits can be cleared in software by writing a '0' to the corresponding bit. More than one flag bit may be set:

- During a power-on reset, both POF and BOF are set but the other flag bits are cleared.
- For any other reset, previously set flag bits that have not been cleared will remain set.

## 8.16 Timers/counters 0 and 1

The P89LPC901/902/903 has two general purpose timers which are similar to the standard 80C51 Timer 0 and Timer 1. These timers have four operating modes (modes 0, 1, 2, and 3). Modes 0, 1, and 2 are the same for both Timers. Mode 3 is different.

### 8.16.1 Mode 0

Putting either Timer into Mode 0 makes it look like an 8048 Timer, which is an 8-bit Counter with a divide-by-32 prescaler. In this mode, the Timer register is configured as a 13-bit register. Mode 0 operation is the same for Timer 0 and Timer 1.

### 8.16.2 Mode 1

Mode 1 is the same as Mode 0, except that all 16 bits of the timer register are used.

### 8.16.3 Mode 2

Mode 2 configures the Timer register as an 8-bit Counter with automatic reload. Mode 2 operation is the same for Timer 0 and Timer 1.

### 8.16.4 Mode 3

When Timer 1 is in Mode 3 it is stopped. Timer 0 in Mode 3 forms two separate 8-bit counters and is provided for applications that require an extra 8-bit timer. When Timer 1 is in Mode 3 it can still be used by the serial port as a baud rate generator.

### 8.16.5 Mode 6 (P89LPC901)

In this mode, the corresponding timer can be changed to a PWM with a full period of 256 timer clocks.

### 8.16.6 Timer overflow toggle output (P89LPC901)

Timers 0 and 1 can be configured to automatically toggle a port output whenever a timer overflow occurs. The same device pins that are used for the T0 and T1 count inputs are also used for the timer toggle outputs. The port outputs will be a logic 1 prior to the first timer overflow when this mode is turned on.

### 8.17 Real-Time clock/system timer

The P89LPC901/902/903 has a simple Real-Time clock that allows a user to continue running an accurate timer while the rest of the device is powered-down. The Real-Time clock can be a wake-up or an interrupt source. The Real-Time clock is a 23-bit down counter comprised of a 7-bit prescaler and a 16-bit loadable down counter. When it reaches all '0's, the counter will be reloaded again and the RTCF flag will be set. The clock source for this counter can be either the CPU clock (CCLK) or the XTAL oscillator, provided that the XTAL oscillator is not being used as the CPU clock. If the XTAL oscillator is used as the CPU clock, then the RTC will use CCLK as its clock source. Only power-on reset will reset the Real-Time clock and its associated SFRs to the default state.

### 8.18 UART (P89LPC903)

The P89LPC903 has an enhanced UART that is compatible with the conventional 80C51 UART except that Timer 2 overflow cannot be used as a baud rate source. The P89LPC903 does include an independent Baud Rate Generator. The baud rate can be selected from the oscillator (divided by a constant), Timer 1 overflow, or the independent Baud Rate Generator. In addition to the baud rate generation, enhancements over the standard 80C51 UART include Framing Error detection, automatic address recognition, selectable double buffering and several interrupt options. The UART can be operated in 4 modes: shift register, 8-bit UART, 9-bit UART, and CPU clock/32 or CPU clock/16.

#### 8.18.1 Mode 0

Serial data enters and exits through RxD. TxD outputs the shift clock. 8 bits are transmitted or received, LSB first. The baud rate is fixed at  $\frac{1}{16}$  of the CPU clock frequency.

#### 8.18.2 Mode 1

10 bits are transmitted (through TxD) or received (through RxD): a start bit (logical '0'), 8 data bits (LSB first), and a stop bit (logical '1'). When data is received, the stop bit is stored in RB8 in Special Function Register SCON. The baud rate is variable and is determined by the Timer 1 overflow rate or the Baud Rate Generator (described in [Section 8.18.5 "Baud rate generator and selection"](#)).

#### 8.18.3 Mode 2

11 bits are transmitted (through TxD) or received (through RxD): start bit (logical '0'), 8 data bits (LSB first), a programmable 9<sup>th</sup> data bit, and a stop bit (logical '1'). When data is transmitted, the 9<sup>th</sup> data bit (TB8 in SCON) can be assigned the value of '0' or '1'. Or, for example, the parity bit (P, in the PSW) could be moved into TB8. When data is received, the 9<sup>th</sup> data bit goes into RB8 in Special Function Register SCON, while the stop bit is not saved. The baud rate is programmable to either  $\frac{1}{16}$  or  $\frac{1}{32}$  of the CPU clock frequency, as determined by the SMOD1 bit in PCON.

#### 8.18.4 Mode 3

11 bits are transmitted (through TxD) or received (through RxD): a start bit (logical '0'), 8 data bits (LSB first), a programmable 9<sup>th</sup> data bit, and a stop bit (logical '1'). In fact, Mode 3 is the same as Mode 2 in all respects except baud rate. The baud rate in Mode 3 is variable and is determined by the Timer 1 overflow rate or the Baud Rate Generator (described in section [Section 8.18.5 "Baud rate generator and selection"](#)).

#### 8.18.5 Baud rate generator and selection

The P89LPC903 enhanced UART has an independent Baud Rate Generator. The baud rate is determined by a baud-rate preprogrammed into the BRGR1 and BRGR0 SFRs which together form a 16-bit baud rate divisor value that works in a similar manner as Timer 1. If the baud rate generator is used, Timer 1 can be used for other timing functions.

The UART can use either Timer 1 or the baud rate generator output (see [Figure 18](#)). Note that Timer T1 is further divided by 2 if the SMOD1 bit (PCON.7) is cleared. The independent Baud Rate Generator uses CCLK.

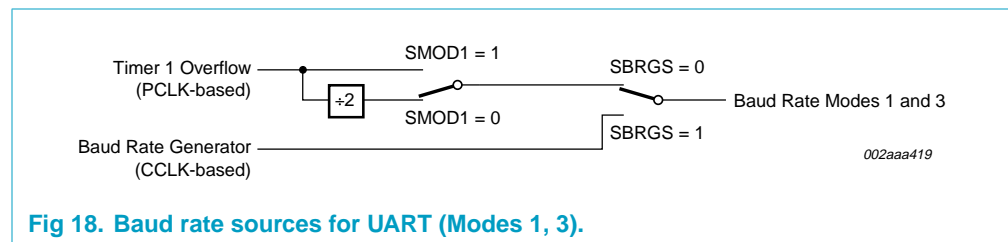

**Fig 18. Baud rate sources for UART (Modes 1, 3).**

#### 8.18.6 Framing error

Framing error is reported in the status register (SSTAT). In addition, if SMOD0 (PCON.6) is '1', framing errors can be made available in SCON.7, respectively. If SMOD0 is '0', SCON.7 is SM0. It is recommended that SM0 and SM1 (SCON.7:6) are set up when SMOD0 is '0'.

#### 8.18.7 Break detect

Break detect is reported in the status register (SSTAT). A break is detected when 11 consecutive bits are sensed LOW. The break detect can be used to reset the device.

#### 8.18.8 Double buffering

The UART has a transmit double buffer that allows buffering of the next character to be written to SBUF while the first character is being transmitted. Double buffering allows transmission of a string of characters with only one stop bit between any two characters, as long as the next character is written between the start bit and the stop bit of the previous character.

Double buffering can be disabled. If disabled (DBMOD, i.e., SSTAT.7 = '0'), the UART is compatible with the conventional 80C51 UART. If enabled, the UART allows writing to SnBUF while the previous data is being shifted out. Double buffering is only allowed in Modes 1, 2 and 3. When operated in Mode 0, double buffering must be disabled (DBMOD = '0').

### 8.18.9 Transmit interrupts with double buffering enabled (Modes 1, 2 and 3)

Unlike the conventional UART, in double buffering mode, the Tx interrupt is generated when the double buffer is ready to receive new data.

### 8.18.10 The 9<sup>th</sup> bit (bit 8) in double buffering (Modes 1, 2 and 3)

If double buffering is disabled TB8 can be written before or after SBUF is written, as long as TB8 is updated some time before that bit is shifted out. TB8 must not be changed until the bit is shifted out, as indicated by the Tx interrupt.

If double buffering is enabled, TB8 **must** be updated before SBUF is written, as TB8 will be double-buffered together with SBUF data.

## 8.19 Analog comparators

One analog comparator is provided on the P89LPC901. Two analog comparators are provided on the P89LPC902 and P89LPC903 devices. Comparator operation is such that the output is a logical one (which may be read in a register) when the positive input is greater than the negative input (selectable from a pin or an internal reference voltage). Otherwise the output is a zero. The comparator may be configured to cause an interrupt when the output value changes.

The connections to the comparator are shown in [Figure 19](#). **Note:** Not all possible comparator configurations are available on all three devices. Please refer to the Logic diagrams in [Section 6 "Logic symbols" on page 12](#). The comparator functions to  $V_{DD} = 2.4\text{ V}$ .

When the comparator is first enabled, the comparator output and interrupt flag are not guaranteed to be stable for 10 microseconds. The comparator interrupt should not be enabled during that time, and the comparator interrupt flag must be cleared before the interrupt is enabled in order to prevent an immediate interrupt service.

When a comparator is disabled the comparator's output, CO<sub>x</sub>, goes HIGH. If the comparator output was LOW and then is disabled, the resulting transition of the comparator output from a LOW to HIGH state will set the comparator flag, CMF<sub>x</sub>. This will cause an interrupt if the comparator interrupt is enabled. The user should therefore disable the comparator interrupt prior to disabling the comparator. Additionally, the user should clear the comparator flag, CMF<sub>x</sub>, after disabling the comparator.

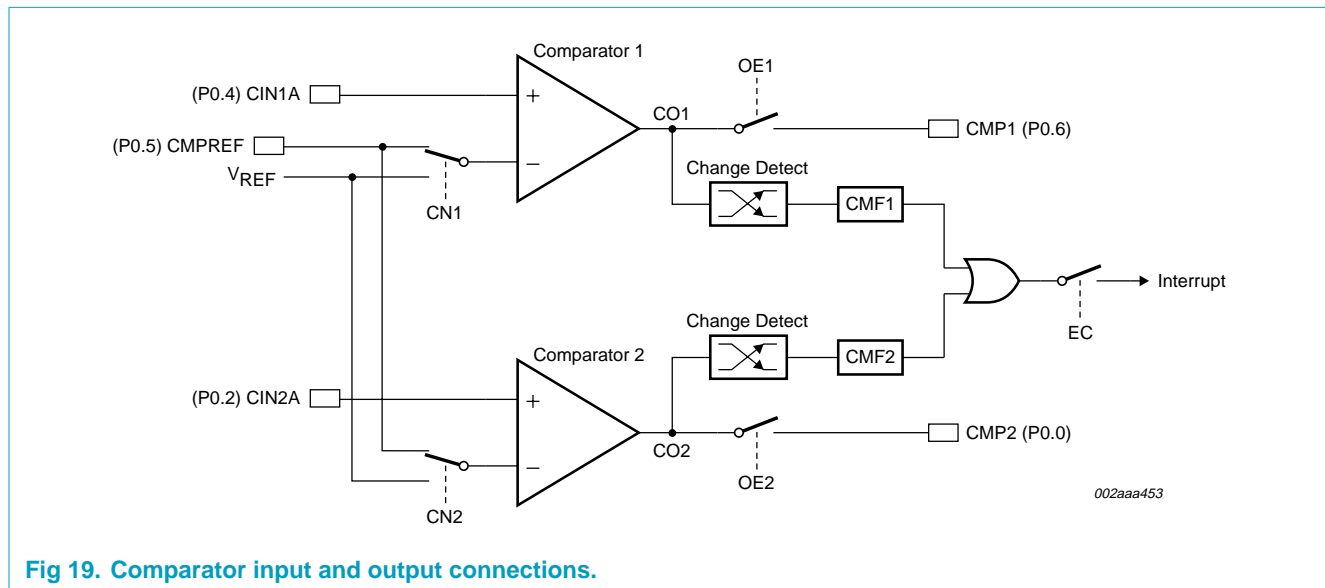

Fig 19. Comparator input and output connections.

## 8.20 Internal reference voltage

An internal reference voltage generator may supply a default reference when a single comparator input pin is used. The value of the internal reference voltage, referred to as  $V_{REF}$ , is  $1.23\text{ V} \pm 10\%$ .

## 8.21 Comparator interrupt

Each comparator has an interrupt flag contained in its configuration register. This flag is set whenever the comparator output changes state. The flag may be polled by software or may be used to generate an interrupt.

## 8.22 Comparator and power reduction modes

The comparators may remain enabled when Power-down or Idle mode is activated, but the comparators are disabled automatically in Total Power-down mode.

If the comparator interrupt is enabled (except in Total Power-down mode), a change of the comparator output state will generate an interrupt and wake up the processor. If the comparator output to a pin is enabled, the pin should be configured in the push-pull mode in order to obtain fast switching times while in Power-down mode. The reason is that with the oscillator stopped, the temporary strong pull-up that normally occurs during switching on a quasi-bidirectional port pin does not take place.

The comparator consumes power in Power-down and Idle modes, as well as in the normal operating mode. This fact should be taken into account when system power consumption is an issue. To minimize power consumption, the user can disable the comparator via PCONA.5 or put the device in Total Power-down mode.

### 8.23 Keypad interrupt (KBI)

The Keypad Interrupt function is intended primarily to allow a single interrupt to be generated when Port 0 is equal to or not equal to a certain pattern. This function can be used for bus address recognition or keypad recognition. The user can configure the port via SFRs for different tasks.

The Keypad Interrupt Mask Register (KBMASK) is used to define which input pins connected to Port 0 can trigger the interrupt. The Keypad Pattern Register (KBPATN) is used to define a pattern that is compared to the value of Port 0. The Keypad Interrupt Flag (KBIF) in the Keypad Interrupt Control Register (KBCON) is set when the condition is matched while the Keypad Interrupt function is active. An interrupt will be generated if enabled. The PATN\_SEL bit in the Keypad Interrupt Control Register (KBCON) is used to define equal or not-equal for the comparison.

In order to use the Keypad Interrupt as an original KBI function like in 87LPC76x series, the user needs to set KBPATN = 0FFH and PATN\_SEL = 1 (not equal), then any key connected to Port 0 which is enabled by the KBMASK register will cause the hardware to set KBIF and generate an interrupt if it has been enabled. The interrupt may be used to wake up the CPU from Idle or Power-down modes. This feature is particularly useful in handheld, battery powered systems that need to carefully manage power consumption yet also need to be convenient to use.

In order to set the flag and cause an interrupt, the pattern on Port 0 must be held longer than six CCLKs.

### 8.24 Watchdog timer

The Watchdog timer causes a system reset when it underflows as a result of a failure to feed the timer prior to the timer reaching its terminal count. It consists of a programmable 12-bit prescaler, and an 8-bit down counter. The down counter is decremented by a tap taken from the prescaler. The clock source for the prescaler is either the PCLK or the nominal 400 kHz Watchdog oscillator. The Watchdog timer can only be reset by a power-on reset. When the Watchdog feature is disabled, it can be used as an interval timer and may generate an interrupt. **Figure 20** shows the Watchdog timer in Watchdog mode. Feeding the watchdog requires a two-byte sequence. If PCLK is selected as the Watchdog clock and the CPU is powered-down, the watchdog is disabled. The Watchdog timer has a time-out period that ranges from a few  $\mu$ s to a few seconds. Please refer to the *P89LPC901/902/903 User's Manual* for more details.



designed to optimize the erase and programming mechanisms. The P89LPC901/902/903 uses  $V_{DD}$  as the supply voltage to perform the Program/Erase algorithms.

### 8.26.2 Features

- Programming and erase over the full operating voltage range.
- Byte-erase allowing code memory to be used for data storage.
- Read/Programming/Erase using ICP.
- Any flash program/erase operation in 2 ms.
- Programming with industry-standard commercial programmers.
- Programmable security for the code in the Flash for each sector.
- More than 100,000 minimum erase/program cycles for each byte.
- 10-year minimum data retention.

### 8.26.3 Flash organization

The P89LPC901/902/903 program memory consists of four 256 byte sectors. Each sector can be further divided into 16-byte pages. In addition to sector erase, page erase, and byte erase, a 16-byte page register is included which allows from 1 to 16 bytes of a given page to be programmed at the same time, substantially reducing overall programming time. In addition, erasing and reprogramming of user-programmable configuration bytes including UCFG1, the Boot Status Bit, and the Boot Vector is supported.

### 8.26.4 Flash programming and erasing

Different methods of erasing or programming of the Flash are available. The Flash may be programmed or erased in the end-user application (IAP) under control of the application's firmware. Another option is to use the In-Circuit Programming (ICP) mechanism. This ICP system provides for programming through a serial clock-serial data interface. Third, the Flash may be programmed or erased using a commercially available EPROM programmer which supports this device. This device does not provide for direct verification of code memory contents. Instead this device provides a 32-bit CRC result on either a sector or the entire 1 KB of user code space.

### 8.26.5 In-circuit programming (ICP)

In-Circuit Programming is performed without removing the microcontroller from the system. The In-Circuit Programming facility consists of internal hardware resources to facilitate remote programming of the P89LPC901/902/903 through a two-wire serial interface. The Philips In-Circuit Programming facility has made in-circuit programming in an embedded application, using commercially available programmers, possible with a minimum of additional expense in components and circuit board area. The ICP function uses five pins. Only a small connector needs to be available to interface your application to a commercial programmer in order to use this feature. Additional details may be found in the *P89LPC901/902/903 User's Manual*.

### 8.26.6 In-application programming

In-Application Programming is performed in the application under the control of the microcontroller's firmware. The IAP facility consists of internal hardware resources to facilitate programming and erasing. The Philips In-Application Programming has made in-application programming in an embedded application possible without additional components. This is accomplished through the use of four SFRs consisting of a control/status register, a data register, and two address registers. Additional details may be found in the *P89LPC901/902/903 User's Manual*.

### 8.26.7 Using flash as data storage

The Flash code memory array of this device supports individual byte erasing and programming. Any byte in the code memory array may be read using the MOVC instruction, provided that the sector containing the byte has not been secured (a MOVC instruction is not allowed to read code memory contents of a secured sector). Thus any byte in a non-secured sector may be used for non-volatile data storage.

### 8.26.8 User configuration bytes

Some user-configurable features of the P89LPC901/902/903 must be defined at power-up and therefore cannot be set by the program after start of execution. These features are configured through the use of the Flash byte UCFG1. Please see the *P89LPC901/902/903 User's Manual* for additional details.

### 8.26.9 User sector security bytes

There are four User Sector Security Bytes, each corresponding to one sector. Please see the *P89LPC901/902/903 User's Manual* for additional details.

## 9. Limiting values

**Table 12: Limiting values**

In accordance with the Absolute Maximum Rating System (IEC 60134).<sup>[1]</sup>

Symbol	Parameter	Conditions	Min	Max	Unit
$T_{\text{amb(bias)}}$	operating bias ambient temperature		-55	+125	°C
$T_{\text{stg}}$	storage temperature range		-65	+150	°C
$V_{\text{xtal}}$	voltage on XTAL1, XTAL2 pin to $V_{\text{SS}}$ , as applicable		-	$V_{\text{DD}} + 0.5$	V
$V_{\text{n}}$	voltage on any other pin to $V_{\text{SS}}$		-0.5	+5.5	V
$I_{\text{OH(I/O)}}$	HIGH-level output current per I/O pin		-	8	mA
$I_{\text{OL(I/O)}}$	LOW-level output current per I/O pin		-	20	mA
$I_{\text{I/O(tot)(max)}}$	maximum total I/O current		-	120	mA
$P_{\text{tot(pack)}}$	total power dissipation per package	based on package heat transfer, not device power consumption	-	1.5	W

[1] The following applies to Limiting values:

- Stresses above those listed under [Table 12](#) may cause permanent damage to the device. This is a stress rating only and functional operation of the device at these or any conditions other than those described in [Table 13 "DC electrical characteristics"](#), [Table 14 "AC characteristics"](#) and [Table 15 "AC characteristics \(P89LPC901\)"](#) of this specification are not implied.
- This product includes circuitry specifically designed for the protection of its internal devices from the damaging effects of excessive static charge. Nonetheless, it is suggested that conventional precautions be taken to avoid applying greater than the rated maximum.
- Parameters are valid over operating temperature range unless otherwise specified. All voltages are with respect to  $V_{\text{SS}}$  unless otherwise noted.

## 10. Static characteristics

**Table 13: DC electrical characteristics**

$V_{DD} = 2.4\text{ V to }3.6\text{ V}$ , unless otherwise specified.

$T_{amb} = -40\text{ }^{\circ}\text{C to }+85\text{ }^{\circ}\text{C}$  for industrial, unless otherwise specified.

Symbol	Parameter	Conditions	Min	Typ <sup>[1]</sup>	Max	Unit
$I_{DD(oper)}$	power supply current, operating (P89LPC901)	3.6 V; 12 MHz	[2] -	11	18	mA
		3.6 V; 18 MHz	[2] -	14	23	mA
$I_{DD(idle)}$	power supply current, Idle mode (P89LPC901)	3.6 V; 12 MHz	[2] -	1	4	mA
		3.6 V; 18 MHz	[2] -	1.5	5.6	mA
$I_{DD(oper)}$	power supply current, operating (P89LPC902, P89LPC903)	3.6 V; 7.373 MHz	[3] -	4	8	mA
$I_{DD(idle)}$	power supply current, Idle mode (P89LPC902, P89LPC903)	3.6 V; 7.373 MHz	[3] -	1	3	mA
$I_{DD(PD)}$	power supply current, Power-down mode, voltage comparators powered-down	3.6 V	[2][3] -	-	70	$\mu\text{A}$
$I_{DD(TPD)}$	power supply current, total Power-down mode	3.6 V	[2][3] -	1	5	$\mu\text{A}$
$(dV_{DD}/dt)_r$	$V_{DD}$ rise rate		-	-	2	$\text{mV}/\mu\text{s}$
$(dV_{DD}/dt)_f$	$V_{DD}$ fall rate		-	-	50	$\text{mV}/\mu\text{s}$
$V_{POR}$	Power-on reset detect voltage		-	-	0.2	V
$V_{RAM}$	RAM keep-alive voltage		1.5	-	-	V
$V_{th(HL)}$	negative-going threshold voltage (Schmitt trigger input)		$0.22V_{DD}$	$0.4V_{DD}$	-	V
$V_{th(LH)}$	positive-going threshold voltage (Schmitt trigger input)		-	$0.6V_{DD}$	$0.7V_{DD}$	V
$V_{hys}$	hysteresis voltage		-	$0.2V_{DD}$	-	V
$V_{OL}$	LOW-level output voltage; all ports, all modes except Hi-Z	$I_{OL} = 20\text{ mA}$	-	0.6	1.0	V
		$I_{OL} = 10\text{ mA}$	-	0.3	0.5	V
		$I_{OL} = 3.2\text{ mA}$	-	0.2	0.3	V
$V_{OH}$	HIGH-level output voltage, all ports	$I_{OH} = -8\text{ mA}$ ; push-pull mode	$V_{DD} - 1.0$	-	-	V
		$I_{OH} = -3.2\text{ mA}$ ; push-pull mode	$V_{DD} - 0.7$	$V_{DD} - 0.4$	-	V
		$I_{OH} = -20\text{ }\mu\text{A}$ ; quasi-bidirectional mode	$V_{DD} - 0.3$	$V_{DD} - 0.2$	-	V
$C_{ig}$	input/output pin capacitance		[4] -	-	15	pF
$I_{IL}$	logical 0 input current, all ports	$V_{IN} = 0.4\text{ V}$	[5] -	-	-80	$\mu\text{A}$
$I_{LI}$	input leakage current, all ports	$V_{IN} = V_{IL}$ or $V_{IH}$	[6] -	-	$\pm 10$	$\mu\text{A}$
$I_{TL}$	logical 1-to-0 transition current, all ports	$V_{IN} = 2.0\text{ V}$ at $V_{DD} = 3.6\text{ V}$	[7][8] -30	-	-450	$\mu\text{A}$
$R_{RST}$	internal reset pull-up resistor		10	-	30	$\text{k}\Omega$

**Table 13: DC electrical characteristics...continued** $V_{DD} = 2.4\text{ V to }3.6\text{ V}$ , unless otherwise specified. $T_{amb} = -40\text{ °C to }+85\text{ °C}$  for industrial, unless otherwise specified.

Symbol	Parameter	Conditions	Min	Typ <sup>[1]</sup>	Max	Unit
$V_{BO}$	brownout trip voltage with BOV = '1', BOPD = '0'	$2.4\text{ V} < V_{DD} < 3.6\text{ V}$	2.40	-	2.70	V
$V_{REF}$	bandgap reference voltage		1.11	1.23	1.34	V
$TC_{(V_{REF})}$	bandgap temperature coefficient		-	10	20	ppm/ °C

[1] Typical ratings are not guaranteed. The values listed are at room temperature, 3 V.

[2] The  $I_{DD(oper)}$ ,  $I_{PD(idle)}$  specifications are measured using an external clock with the following functions disabled: comparators, brownout detect, and Watchdog timer (P89LPC901).

[3] The  $I_{DD(oper)}$ ,  $I_{PD(idle)}$  specifications are measured with the following functions disabled: comparators, brownout detect, and Watchdog timer (P89LPC902, P89LPC903).

[4] Pin capacitance is characterized but not tested.

[5] Measured with port in quasi-bidirectional mode.

[6] Measured with port in high-impedance mode.

[7] Ports in quasi-bidirectional mode with weak pull-up (applies to all port pins with pull-ups)

[8] Port pins source a transition current when used in quasi-bidirectional mode and externally driven from '1' to '0'. This current is highest when  $V_{IN}$  is approximately 2 V.

## 11. Dynamic characteristics

**Table 14: AC characteristics**

$V_{DD} = 2.4\text{ V to }3.6\text{ V}$ , unless otherwise specified.

$T_{amb} = -40\text{ °C to }+85\text{ °C}$  for industrial, unless otherwise specified.<sup>[1]</sup>

Symbol	Parameter	Conditions	Variable clock		$f_{osc} = 12\text{ MHz}$		Unit
			Min	Max	Min	Max	
$f_{RCOSC}$	internal RC oscillator frequency (nominal $f = 7.3728\text{ MHz}$ ) trimmed to $\pm 1\%$ at $T_{amb} = 25\text{ °C}$		7.189	7.557	7.189	7.557	MHz
$f_{WDOSC}$	internal Watchdog oscillator frequency (nominal $f = 400\text{ kHz}$ )		320	520	320	520	kHz

### Crystal oscillator (P89LPC901)

$f_{osc}$	oscillator frequency		0	12	-	-	MHz
$t_{CLCL}$	clock cycle	see Figure 22	83	-	-	-	ns
$f_{CLKP}$	CLKLP active frequency		0	8	-	-	MHz

### Glitch filter

	glitch rejection, P1.5/ $\overline{RST}$ pin		-	50	-	50	ns
	signal acceptance, P1.5/ $\overline{RST}$ pin		125	-	125	-	ns
	glitch rejection, any pin except P1.5/ $\overline{RST}$		-	15	-	15	ns
	signal acceptance, any pin except P1.5/ $\overline{RST}$		50	-	50	-	ns

### External clock (P89LPC901)

$t_{CHCX}$	HIGH time	see Figure 22	33	$t_{CLCL} - t_{CLCX}$	33	-	ns
$t_{CLCX}$	LOW time	see Figure 22	33	$t_{CLCL} - t_{CHCX}$	33	-	ns
$t_{CLCH}$	rise time	see Figure 22	-	8	-	8	ns
$t_{CHCL}$	fall time	see Figure 22	-	8	-	8	ns

### Shift register (UART mode 0 - P89LPC903)

$t_{XLXL}$	serial port clock cycle time	see Figure 21	16 $t_{CLCL}$	-	1333	-	ns
$t_{QVXH}$	output data set-up to clock rising edge	see Figure 21	13 $t_{CLCL}$	-	1083	-	ns
$t_{XHGX}$	output data hold after clock rising edge	see Figure 21	-	$t_{CLCL} + 20$	-	103	ns
$t_{XHDX}$	input data hold after clock rising edge	see Figure 21	-	0	-	0	ns
$t_{DVXH}$	input data valid to clock rising edge	see Figure 21	150	-	150	-	ns

[1] Parameters are valid over operating temperature range unless otherwise specified. Parts are tested to 2 MHz, but are guaranteed to operate down to 0 Hz.



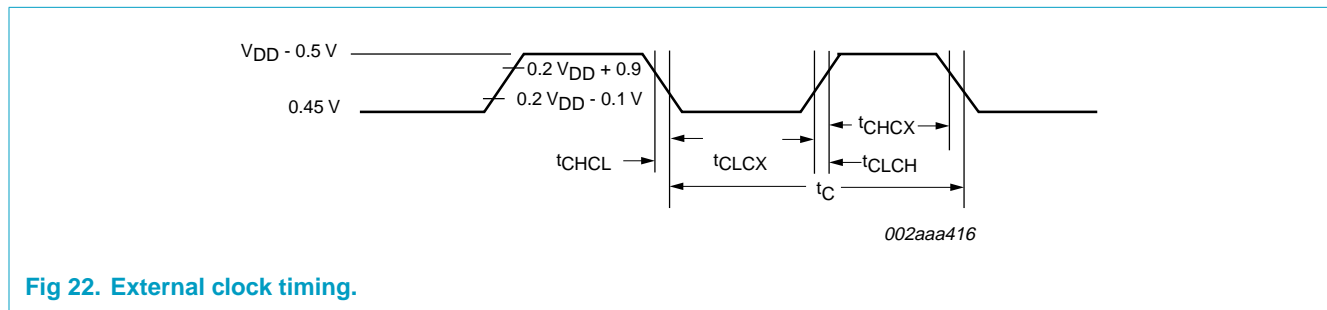

Fig 22. External clock timing.

## 12. Comparator electrical characteristics

**Table 16: Comparator electrical characteristics**

$V_{DD} = 2.4\text{ V to }3.6\text{ V}$ , unless otherwise specified.

$T_{amb} = -40\text{ }^{\circ}\text{C to }+85\text{ }^{\circ}\text{C}$  for industrial, unless otherwise specified.

Symbol	Parameter	Conditions	Min	Typ	Max	Unit
$V_{IO}$	offset voltage comparator inputs		-	-	$\pm 20$	mV
$V_{CR}$	common mode range comparator inputs		0	-	$V_{DD} - 0.3$	V
CMRR	common mode rejection ratio		[1] -	-	-50	dB
	response time		-	250	500	ns
	comparator enable to output valid		-	-	10	$\mu\text{s}$
$I_{IL}$	input leakage current, comparator	$0 < V_{IN} < V_{DD}$	-	-	$\pm 10$	$\mu\text{A}$

[1] This parameter is characterized, but not tested in production.

13. Package outline

SO8: plastic small outline package; 8 leads; body width 3.9 mm

SOT96-1

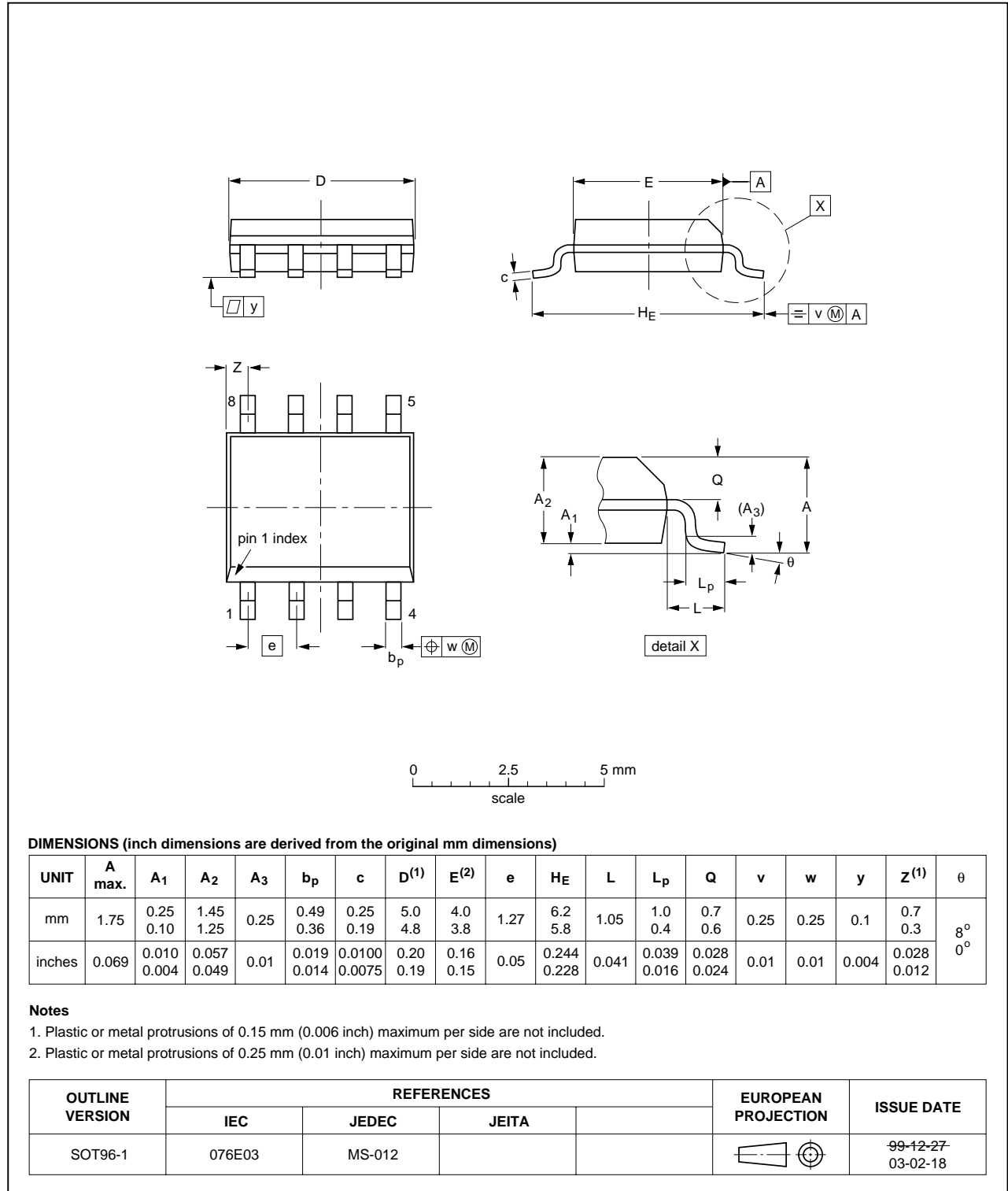

Fig 23. SOT96-1 (SO8).

DIP8: plastic dual in-line package; 8 leads (300 mil)

SOT97-1

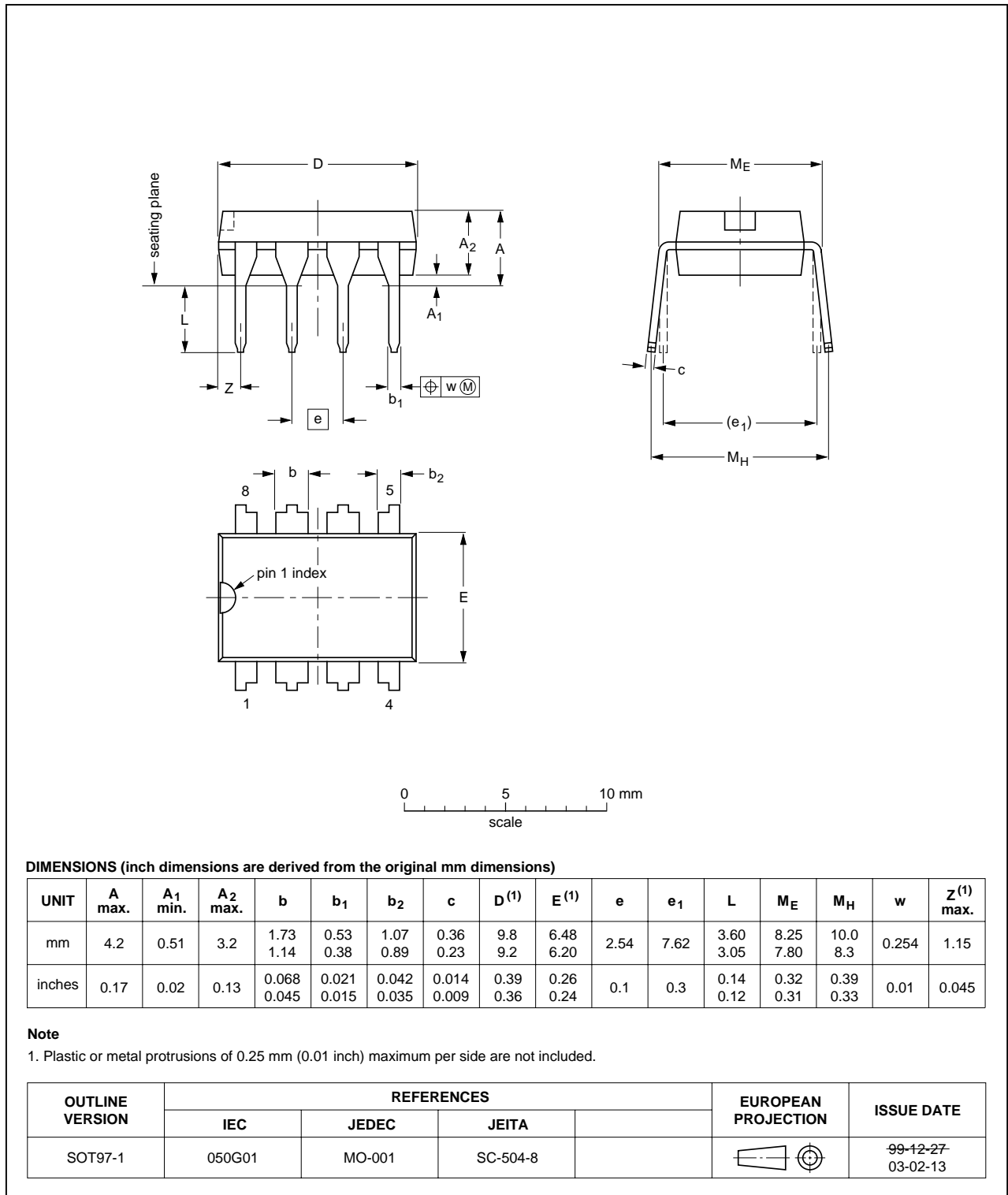

Fig 24. SOT97-1 (DIP8).

## 14. Revision history

Table 17: Revision history

Rev	Date	CPCN	Description
05	20041217	-	<b>Product data (9397 750 14465)</b> Modifications: <ul style="list-style-type: none"><li>• Added 18 MHz information.</li></ul>
04	20031121	-	<b>Product data (9397 750 12293); ECN 853-2434 01-A14555 of 18 November 2003</b>
03	20030929	-	<b>Product data (9397 750 12031); ECN 853-2434 30348 of 11 September 2003</b>
02	20030731	-	<b>Product data (9397 750 11801); ECN 853-2434 30152 of 28 July 2003</b>
01	20030602	-	<b>Preliminary data (9397 750 11494)</b>

## 15. Data sheet status

Level	Data sheet status <sup>[1]</sup>	Product status <sup>[2][3]</sup>	Definition
I	Objective data	Development	This data sheet contains data from the objective specification for product development. Philips Semiconductors reserves the right to change the specification in any manner without notice.
II	Preliminary data	Qualification	This data sheet contains data from the preliminary specification. Supplementary data will be published at a later date. Philips Semiconductors reserves the right to change the specification without notice, in order to improve the design and supply the best possible product.
III	Product data	Production	This data sheet contains data from the product specification. Philips Semiconductors reserves the right to make changes at any time in order to improve the design, manufacturing and supply. Relevant changes will be communicated via a Customer Product/Process Change Notification (CPCN).

[1] Please consult the most recently issued data sheet before initiating or completing a design.

[2] The product status of the device(s) described in this data sheet may have changed since this data sheet was published. The latest information is available on the Internet at URL <http://www.semiconductors.philips.com>.

[3] For data sheets describing multiple type numbers, the highest-level product status determines the data sheet status.

## 16. Definitions

**Short-form specification** — The data in a short-form specification is extracted from a full data sheet with the same type number and title. For detailed information see the relevant data sheet or data handbook.

**Limiting values definition** — Limiting values given are in accordance with the Absolute Maximum Rating System (IEC 60134). Stress above one or more of the limiting values may cause permanent damage to the device. These are stress ratings only and operation of the device at these or at any other conditions above those given in the Characteristics sections of the specification is not implied. Exposure to limiting values for extended periods may affect device reliability.

**Application information** — Applications that are described herein for any of these products are for illustrative purposes only. Philips Semiconductors make no representation or warranty that such applications will be suitable for the specified use without further testing or modification.

## 17. Disclaimers

**Life support** — These products are not designed for use in life support appliances, devices, or systems where malfunction of these products can reasonably be expected to result in personal injury. Philips Semiconductors customers using or selling these products for use in such applications do so at their own risk and agree to fully indemnify Philips Semiconductors for any damages resulting from such application.

**Right to make changes** — Philips Semiconductors reserves the right to make changes in the products - including circuits, standard cells, and/or software - described or contained herein in order to improve design and/or performance. When the product is in full production (status 'Production'), relevant changes will be communicated via a Customer Product/Process Change Notification (CPCN). Philips Semiconductors assumes no responsibility or liability for the use of any of these products, conveys no licence or title under any patent, copyright, or mask work right to these products, and makes no representations or warranties that these products are free from patent, copyright, or mask work right infringement, unless otherwise specified.

## Contact information

For additional information, please visit <http://www.semiconductors.philips.com>.

For sales office addresses, send e-mail to: [sales.addresses@www.semiconductors.philips.com](mailto:sales.addresses@www.semiconductors.philips.com).

Fax: +31 40 27 24825

## Contents

<b>1</b>	<b>General description</b> . . . . .	<b>1</b>	8.16.6	Timer overflow toggle output (P89LPC901) . . . . .	35
<b>2</b>	<b>Features</b> . . . . .	<b>1</b>	8.17	Real-Time clock/system timer . . . . .	35
2.1	Principal features . . . . .	1	8.18	UART (P89LPC903) . . . . .	35
2.2	Additional features . . . . .	1	8.18.1	Mode 0 . . . . .	35
<b>3</b>	<b>Ordering information</b> . . . . .	<b>3</b>	8.18.2	Mode 1 . . . . .	35
3.1	Ordering options . . . . .	3	8.18.3	Mode 2 . . . . .	35
<b>4</b>	<b>Block diagram</b> . . . . .	<b>4</b>	8.18.4	Mode 3 . . . . .	36
<b>5</b>	<b>Pinning information</b> . . . . .	<b>7</b>	8.18.5	Baud rate generator and selection . . . . .	36
5.1	Pinning . . . . .	7	8.18.6	Framing error . . . . .	36
5.2	Pin description . . . . .	8	8.18.7	Break detect . . . . .	36
<b>6</b>	<b>Logic symbols</b> . . . . .	<b>12</b>	8.18.8	Double buffering . . . . .	36
<b>7</b>	<b>Special function registers</b> . . . . .	<b>14</b>	8.18.9	Transmit interrupts with double buffering enabled (Modes 1, 2 and 3) . . . . .	37
<b>8</b>	<b>Functional description</b> . . . . .	<b>24</b>	8.18.10	The 9 <sup>th</sup> bit (bit 8) in double buffering (Modes 1, 2 and 3) . . . . .	37
8.1	Enhanced CPU . . . . .	24	8.19	Analog comparators . . . . .	37
8.2	Clocks . . . . .	24	8.20	Internal reference voltage . . . . .	38
8.2.1	Clock definitions . . . . .	24	8.21	Comparator interrupt . . . . .	38
8.2.2	CPU clock (OSCCLK) . . . . .	24	8.22	Comparator and power reduction modes . . . . .	38
8.2.3	Low speed oscillator option (P89LPC901) . . . . .	24	8.23	Keypad interrupt (KBI) . . . . .	39
8.2.4	Medium speed oscillator option (P89LPC901) . . . . .	24	8.24	Watchdog timer . . . . .	39
8.2.5	High speed oscillator option (P89LPC901) . . . . .	25	8.25	Additional features . . . . .	40
8.2.6	Clock output (P89LPC901) . . . . .	25	8.25.1	Software reset . . . . .	40
8.3	On-chip RC oscillator option . . . . .	25	8.25.2	Dual data pointers . . . . .	40
8.4	Watchdog oscillator option . . . . .	25	8.26	Flash program memory . . . . .	40
8.5	External clock input option (P89LPC901) . . . . .	25	8.26.1	General description . . . . .	40
8.6	CPU CLock (CCLK) wake-up delay . . . . .	27	8.26.2	Features . . . . .	41
8.7	CPU CLOCK (CCLK) modification: DIVM register . . . . .	27	8.26.3	Flash organization . . . . .	41
8.8	Low power select . . . . .	27	8.26.4	Flash programming and erasing . . . . .	41
8.9	Memory organization . . . . .	27	8.26.5	In-circuit programming (ICP) . . . . .	41
8.10	Data RAM arrangement . . . . .	27	8.26.6	In-application programming . . . . .	42
8.11	Interrupts . . . . .	27	8.26.7	Using flash as data storage . . . . .	42
8.11.1	External interrupt inputs . . . . .	28	8.26.8	User configuration bytes . . . . .	42
8.12	I/O ports . . . . .	30	8.26.9	User sector security bytes . . . . .	42
8.12.1	Port configurations . . . . .	30	<b>9</b>	<b>Limiting values</b> . . . . .	<b>43</b>
8.12.2	Quasi-bidirectional output configuration . . . . .	31	<b>10</b>	<b>Static characteristics</b> . . . . .	<b>44</b>
8.12.3	Open-drain output configuration . . . . .	31	<b>11</b>	<b>Dynamic characteristics</b> . . . . .	<b>46</b>
8.12.4	Input-only configuration . . . . .	31	<b>12</b>	<b>Comparator electrical characteristics</b> . . . . .	<b>48</b>
8.12.5	Push-pull output configuration . . . . .	31	<b>13</b>	<b>Package outline</b> . . . . .	<b>49</b>
8.12.6	Port 0 analog functions . . . . .	31	<b>14</b>	<b>Revision history</b> . . . . .	<b>51</b>
8.12.7	Additional port features . . . . .	32	<b>15</b>	<b>Data sheet status</b> . . . . .	<b>52</b>
8.13	Power monitoring functions . . . . .	32	<b>16</b>	<b>Definitions</b> . . . . .	<b>52</b>
8.13.1	Brownout detection . . . . .	32	<b>17</b>	<b>Disclaimers</b> . . . . .	<b>52</b>
8.13.2	Power-on detection . . . . .	32			
8.14	Power reduction modes . . . . .	32			
8.14.1	Idle mode . . . . .	33			
8.14.2	Power-down mode . . . . .	33			
8.14.3	Total Power-down mode . . . . .	33			
8.15	Reset . . . . .	33			
8.16	Timers/counters 0 and 1 . . . . .	34			
8.16.1	Mode 0 . . . . .	34			
8.16.2	Mode 1 . . . . .	34			
8.16.3	Mode 2 . . . . .	34			
8.16.4	Mode 3 . . . . .	34			
8.16.5	Mode 6 (P89LPC901) . . . . .	34			



**PHILIPS**

*Let's make things better.*

## Looking for pricing, stock, or lifecycle information?

Click below to explore more details on WIN SOURCE:

 [View P89LPC901FD,112 on WIN SOURCE](#)

 [NXP / Nexperia Information](#)

## Optimize Your Supply Chain with WIN SOURCE Solutions

-  Global Sourcing Solution
-  Obsolete Management
-  Cost Control Management
-  Shortage Management
-  Alternative Solution
-  Excess Inventory Management