

## 2K I<sup>2</sup>C™ Serial EEPROM Software Write-Protect

### Features:

- Permanent and Resettable Software Write-Protect for Lower Half of the Array (00h-7Fh)
- Single Supply with Operation Down to 1.5V
- Low-Power CMOS Technology:
  - Read current 1 mA, typical
  - Standby current, 100 nA, typical
- 2-Wire Serial Interface Bus, I<sup>2</sup>C™ Compatible
- Cascadable up to Eight Devices
- Schmitt Trigger Inputs for Noise Suppression
- Output Slope Control to Eliminate Ground Bounce
- 100 kHz and 400 kHz Compatibility
- Page Write Time 3 ms, typical
- Self-Timed Erase/Write Cycle
- 16-Byte Page Write Buffer
- ESD Protection > 4,000V
- Hardware Write Protection for Entire Array
- More than 1 Million Erase/Write Cycles
- Data Retention > 200 Years
- 8-Lead PDIP, SOIC, TSSOP, MSOP and TDFN packages
- 6-Lead SOT-23 Package
- Pb-free and RoHS Compliant
- Temperature Range:
  - -20°C to +85°C

### Device Selection Table

| Part Number | V <sub>CC</sub> Range | Max. Clock Frequency   |
|-------------|-----------------------|------------------------|
| 34VL02      | 1.5-3.6               | 400 kHz <sup>(1)</sup> |

**Note 1:** 100 kHz for V<sub>CC</sub> < 1.8V

### Package Types

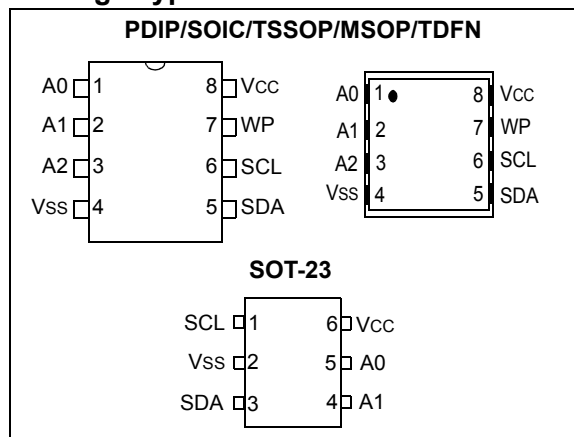

### Description:

The Microchip Technology Inc. 34VL02 is a 2 Kbit Electrically Erasable PROM capable of operation across a broad voltage range (1.5V to 3.6V). This device has two software write-protect features for the lower half of the array, as well as an external pin that can be used to write-protect the entire array. This allows the system designer to protect none, half, or all of the array, depending on the application. The device is organized as one block of 256 x 8-bit memory with a 2-wire serial interface. Low-voltage design permits operation down to 1.5V, with standby and active currents of only 100 nA and 1 mA, respectively. The 34VL02 also has a page write capability for up to 16 bytes of data. The 34VL02 is available in the standard 8-pin PDIP, surface mount SOIC, TSSOP, MSOP and TDFN packages. The 34VL02 is also available in the 6-lead, SOT-23 package.

# 34VL02

## Block Diagram

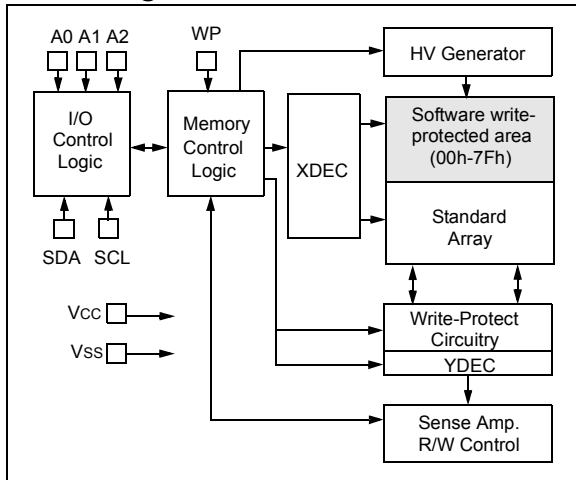

## 1.0 ELECTRICAL CHARACTERISTICS

### Absolute Maximum Ratings<sup>(†)</sup>

|   |                                |
|---|--------------------------------|
| V <sub>CC</sub> .....                               | 6.5V                           |
| All inputs and outputs w.r.t. V <sub>SS</sub> ..... | -0.3V to V <sub>CC</sub> +1.0V |
| Storage temperature .....                           | -65°C to +150°C                |
| Ambient temperature with power applied.....         | -20°C to +85°C                 |
| ESD protection on all pins .....                    | ≥ 4 kV                         |

† **NOTICE:** Stresses above those listed under “Absolute Maximum Ratings” may cause permanent damage to the device. These are stress ratings only and functional operation of the device at these or any other conditions above those indicated in the operation sections of the specifications is not implied. Exposure to Absolute Maximum Rating conditions for extended periods may affect device reliability.

**TABLE 1-1: DC SPECIFICATIONS**

| DC CHARACTERISTICS |                                       |   | V <sub>CC</sub> = +1.5V to +3.6V<br>Temperature Range: -20°C to +85°C |      |                     |       |   |
|--------------------|---------------------------------------|---|---|------|---------------------|-------|---|
| Param. No.         | Symbol                                | Characteristic                          | Min.  | Typ. | Max.                | Units | Conditions  |
|                    | —                                     | <b>A0, A1, A2, SCL, SDA and WP pins</b> | —   | —    | —                   | —     | —   |
| D1                 | V <sub>IH</sub>                       | High-level input voltage                | 0.7 V <sub>CC</sub>   | —    | —                   | V     | —   |
| D2                 | V <sub>IL</sub>                       | Low-level input voltage                 | —   | —    | 0.3 V <sub>CC</sub> | V     | 0.2 V <sub>CC</sub> for V <sub>CC</sub> < 2.5V                  |
| D3                 | V <sub>HYS</sub>                      | Hysteresis of Schmitt Trigger inputs    | 0.05 V <sub>CC</sub>  | —    | —                   | V     | <b>(Note)</b>   |
| D4                 | V <sub>OL</sub>                       | Low-level output voltage                | —   | —    | 0.40                | V     | I <sub>OL</sub> = 3.0 mA, V <sub>CC</sub> = 2.5V                |
| D5                 | V <sub>HV</sub>                       | High-Voltage Detect                     | 7   | —    | 10                  | V     | A0 Pin only, V <sub>CC</sub> < 2.2V                             |
|                    |                                       |   | V <sub>CC</sub> + 4.8   | —    | 10                  | V     | A0 Pin only, V <sub>CC</sub> ≥ 2.2V                             |
| D6                 | I <sub>LI</sub>                       | Input leakage current                   | —   | —    | ±1                  | μA    | V <sub>IN</sub> = V <sub>SS</sub> or V <sub>CC</sub>            |
| D7                 | I <sub>LO</sub>                       | Output leakage current                  | —   | —    | ±1                  | μA    | V <sub>OUT</sub> = V <sub>SS</sub> or V <sub>CC</sub>           |
| D8                 | C <sub>IN</sub> ,<br>C <sub>OUT</sub> | Pin capacitance<br>(all inputs/outputs) | —   | —    | 10                  | pF    | V <sub>CC</sub> = 3.6V <b>(Note)</b><br>T <sub>A</sub> = 25°C   |
| D9                 | I <sub>CC</sub> write                 | Operating current                       | —   | 0.1  | 3                   | mA    | V <sub>CC</sub> = 3.6V  |
| D10                | I <sub>CC</sub> read                  |   | —   | 0.05 | 1                   | mA    | —   |
| D11                | I <sub>CCS</sub>                      | Standby current                         | —   | 0.01 | 1                   | μA    | SDA = SCL = V <sub>CC</sub><br>A0, A1, A2, WP = V <sub>SS</sub> |

**Note:** This parameter is periodically sampled and not 100% tested.

**TABLE 1-2: AC SPECIFICATIONS**

| AC CHARACTERISTICS |         |  | VCC = +1.5V to +3.6V<br>Temperature Range: -20°C to +85°C |             |        |  |
|--------------------|---------|--|---|-------------|--------|--|
| Param. No.         | Symbol  | Characteristic   | Min.  | Max.        | Units  | Conditions                             |
| 1                  | FCLK    | Clock frequency  | —<br>—  | 100<br>400  | kHz    | 1.5V ≤ VCC < 1.8V<br>1.8V ≤ VCC ≤ 3.6V |
| 2                  | THIGH   | Clock high time  | 4000<br>600   | —<br>—      | ns     | 1.5V ≤ VCC < 1.8V<br>1.8V ≤ VCC ≤ 3.6V |
| 3                  | TLOW    | Clock low time   | 4700<br>1300  | —<br>—      | ns     | 1.5V ≤ VCC < 1.8V<br>1.8V ≤ VCC ≤ 3.6V |
| 4                  | TR      | SDA and SCL rise time (Note 1)   | —<br>—  | 1000<br>300 | ns     | 1.5V ≤ VCC < 1.8V<br>1.8V ≤ VCC ≤ 3.6V |
| 5                  | TF      | SDA and SCL fall time (Note 1)   | —<br>—  | 1000<br>300 | ns     | 1.5V ≤ VCC < 1.8V<br>1.8V ≤ VCC ≤ 3.6V |
| 6                  | THD:STA | Start condition hold time  | 4000<br>600   | —<br>—      | ns     | 1.5V ≤ VCC < 1.8V<br>1.8V ≤ VCC ≤ 3.6V |
| 7                  | TSU:STA | Start condition setup time   | 4700<br>600   | —<br>—      | ns     | 1.5V ≤ VCC < 1.8V<br>1.8V ≤ VCC ≤ 3.6V |
| 8                  | THD:DAT | Data input hold time   | 0   | —           | ns     | (Note 2)                               |
| 9                  | TSU:DAT | Data input setup time  | 250<br>100  | —<br>—      | ns     | 1.5V ≤ VCC < 1.8V<br>1.8V ≤ VCC ≤ 3.6V |
| 10                 | TSU:STO | Stop condition setup time  | 4000<br>600   | —<br>—      | ns     | 1.5V ≤ VCC < 1.8V<br>1.8V ≤ VCC ≤ 3.6V |
| 11                 | TSU:WP  | WP setup time  | 4000<br>600   | —<br>—      | ns     | 1.5V ≤ VCC < 1.8V<br>1.8V ≤ VCC ≤ 3.6V |
| 12                 | THD:WP  | WP hold time   | 4700<br>600   | —<br>—      | ns     | 1.5V ≤ VCC < 1.8V<br>1.8V ≤ VCC ≤ 3.6V |
| 13                 | TAA     | Output valid from clock (Note 2)   | —<br>—  | 3500<br>900 | ns     | 1.5V ≤ VCC < 1.8V<br>1.8V ≤ VCC ≤ 3.6V |
| 14                 | TBUF    | Bus free time: Time the bus must be free before a new transmission can start | 1300<br>4700  | —<br>—      | ns     | 1.5V ≤ VCC < 1.8V<br>1.8V ≤ VCC ≤ 3.6V |
| 16                 | TSP     | Input filter spike suppression (SDA and SCL pins)                            | —   | 50          | ns     | (Note 1 and Note 3)                    |
| 17                 | TWC     | Write cycle time (byte or page)  | —   | 5           | ms     | —                                      |
| 18                 | —       | Endurance  | 1M  | —           | cycles | 25°C, VCC = 3.6V, Block mode (Note 4)  |

- Note 1:** Not 100% tested. CB = total capacitance of one bus line in pF.
- Note 2:** As a transmitter, the device must provide an internal minimum delay time to bridge the undefined region (minimum 300 ns) of the falling edge of SCL to avoid unintended generation of Start or Stop conditions.
- Note 3:** The combined TSP and VHYS specifications are due to new Schmitt Trigger inputs, which provide improved noise spike suppression. This eliminates the need for a Ti specification for standard operation.
- Note 4:** This parameter is not tested but ensured by characterization. For endurance estimates in a specific application, please consult the Total Endurance™ Model which can be obtained from Microchip's web site at [www.microchip.com](http://www.microchip.com).

**FIGURE 1-1: BUS TIMING DATA**

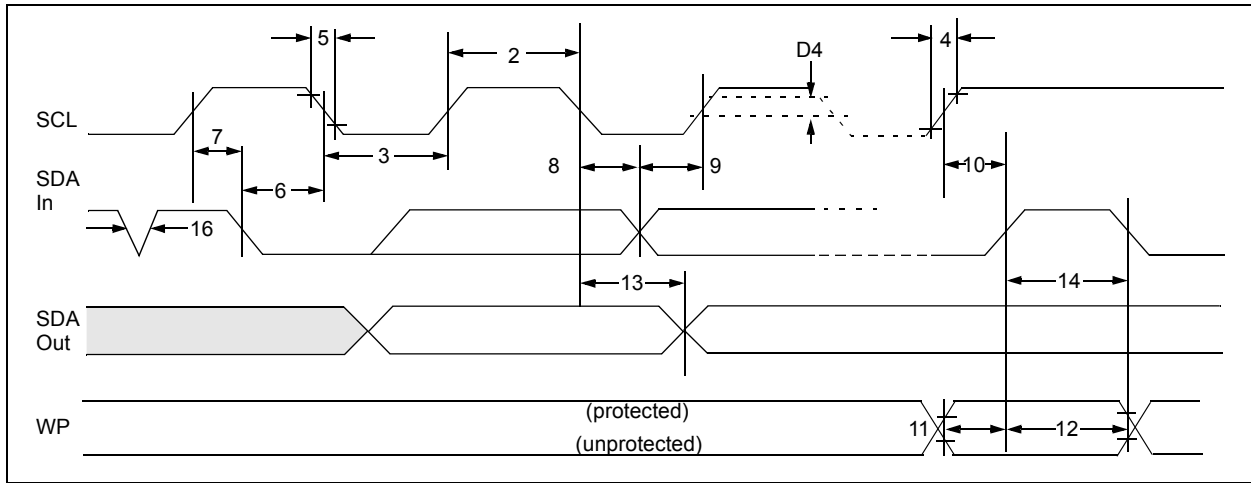

## 2.0 FUNCTIONAL DESCRIPTION

The 34VL02 has two Software Write-Protect features that allow you to protect half of the array from being written (Addresses 00h-7Fh). One command, Software Write-Protect (SWP) will prevent writes to half of the array and is resettable by using the Clear Software Write-Protect (CSWP) command. The other command is Permanent Software Write-Protect (PSWP), which is not resettable and will permanently lock half the array from being written to. The device still has an external pin (WP) that allows you to protect the entire array if so desired.

The 34VL02 supports a bidirectional 2-wire bus and data transmission protocol. A device that sends data onto the bus is defined as a transmitter, and a device receiving data, as a receiver. The bus has to be controlled by a master device, which generates the Serial Clock (SCL), controls the bus access and generates the Start and Stop conditions, while the 34VL02 works as slave. Both master and slave can operate as transmitter or receiver, but the master device determines which mode is activated.

## 3.0 BUS CHARACTERISTICS

The following **bus protocol** has been defined:

- Data transfer may be initiated only when the bus is not busy.
- During data transfer, the data line must remain stable whenever the clock line is high. Changes in the data line while the clock line is high will be interpreted as a Start or Stop condition.

Accordingly, the following bus conditions have been defined (Figure 3-1).

### 3.1 Bus Not Busy (A)

Both data and clock lines remain high.

### 3.2 Start Data Transfer (B)

A high-to-low transition of the SDA line while the clock (SCL) is high determines a Start condition. All commands must be preceded by a Start condition.

### 3.3 Stop Data Transfer (C)

A low-to-high transition of the SDA line while the clock (SCL) is high determines a Stop condition. All operations must be ended with a Stop condition.

### 3.4 Data Valid (D)

The state of the data line represents valid data when, after a Start condition, the data line is stable for the duration of the high period of the clock signal.

The data on the line must be changed during the low period of the clock signal. There is one clock pulse per bit of data.

Each data transfer is initiated with a Start condition and terminated with a Stop condition. The number of data bytes transferred between the Start and Stop conditions is determined by the master device and is, theoretically, unlimited; although only the last sixteen will be stored when doing a write operation. When an overwrite does occur, it will replace data in a first-in, first-out (FIFO) fashion.

## 3.5 Acknowledge

Each receiving device, when addressed, is obliged to generate an Acknowledge after the reception of each byte. Exceptions to this rule relating to software write protection are described in **Section 7.0 “Write Protection”**. The master device must generate an extra clock pulse, which is associated with this Acknowledge bit.

|   |
|---|
| <b>Note:</b> The 34VL02 does not generate any Acknowledge bits if an internal programming cycle is in progress. |
|---|

The device that acknowledges has to pull down the SDA line during the Acknowledge clock pulse in such a way that the SDA line is stable low during the high period of the acknowledge related clock pulse. Of course, setup and hold times must be taken into account. During reads, a master must signal an end-of-data to the slave by not generating an Acknowledge bit on the last byte that has been clocked out of the slave. In this case, the slave (34VL02) will leave the data line high to enable the master to generate the Stop condition.

**FIGURE 3-1: DATA TRANSFER SEQUENCE ON THE SERIAL BUS**

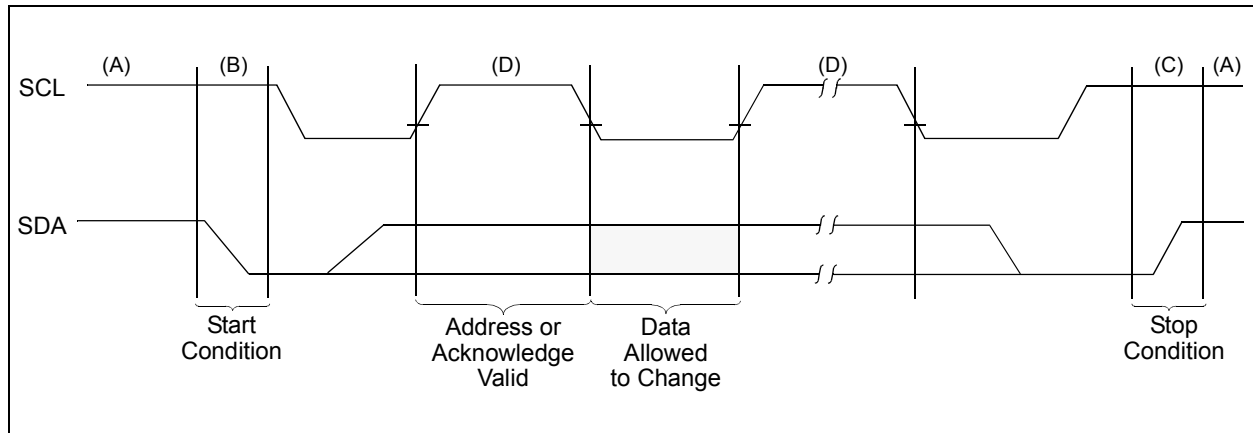

### 3.6 Device Addressing

A control byte is the first byte received following the Start condition from the master device. The first part of the control byte consists of a 4-bit control code which is set to '1010' for normal read and write operations and '0110' for writing to the write-protect register. The control byte is followed by three Chip Select bits (A2, A1, A0). The Chip Select bits allow the use of up to eight 34VL02 devices on the same bus and are used to determine which device is accessed. The Chip Select bits in the control byte must correspond to the logic levels on the corresponding A2, A1 and A0 pins for the device to respond.

The eighth bit of slave address determines if the master device wants to read or write to the 34VL02 (Figure 3-2). When set to a one, a read operation is selected. When set to a zero, a write operation is selected.

| Operation              | Control Code | Chip Select | R/W |
|------------------------|--------------|-------------|-----|
| Read                   | 1010         | A2 A1 A0    | 1   |
| Write                  | 1010         | A2 A1 A0    | 0   |
| Write-Protect Register | 0110         | A2 A1 A0    | 0   |

**FIGURE 3-2: CONTROL BYTE ALLOCATION**

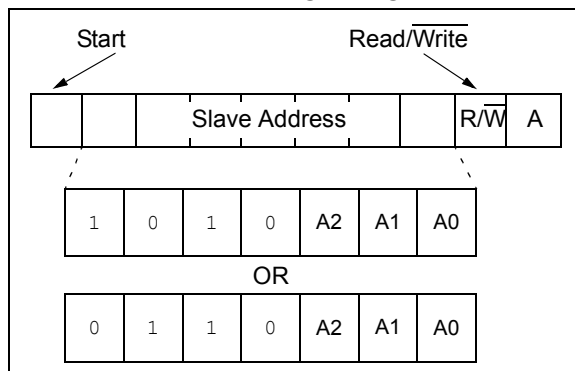

### 4.0 WRITE OPERATIONS

#### 4.1 Byte Write

Following the Start signal from the master, the device code (4 bits), the Chip Select bits (3 bits) and the R/W bit, which is a logic low, are placed onto the bus by the master transmitter. This indicates to the addressed slave receiver that a byte with a word address will follow, once it has generated an Acknowledge bit during the ninth clock cycle. Therefore, the next byte transmitted by the master is the word address and will be written into the Address Pointer of the 34VL02.

After receiving another Acknowledge signal from the 34VL02, the master device will transmit the data word to be written into the addressed memory location. The 34VL02 acknowledges again and the master generates a Stop condition. This initiates the internal write cycle, which means that during this time, the 34VL02 will not generate Acknowledge signals (Figure 4-1). If an attempt is made to write to the array when the software or hardware write protection has been enabled, the device will acknowledge the command, but no data will be written. The write cycle time must be observed even if the write protection is enabled.

#### 4.2 Page Write

The write control byte, word address and the first data byte are transmitted to the 34VL02 in the same way as in a byte write. Instead of generating a Stop condition, the master transmits up to 15 additional data bytes to the 34VL02, which are temporarily stored in the on-chip page buffer and will be written into the memory after the master has transmitted a Stop condition. Upon receipt of each word, the four lower order Address Pointer bits are internally incremented by one. The higher order four bits of the word address remain constant. If the master should transmit more than 16 bytes prior to generating the Stop condition, the address counter will roll over and the previously received data will be overwritten. As with the byte write operation, once the Stop condition is received, an internal write cycle will begin.

# 34VL02

(Figure 4-2). If an attempt is made to write to the array when the hardware write protection has been enabled, the device will acknowledge the command, but no data will be written. The write cycle time must be observed even if the write protection is enabled.

**Note:** Page write operations are limited to writing bytes within a single physical page, regardless of the number of bytes actually being written. Physical page boundaries start at addresses that are integer multiples of the page buffer size (or 'page size') and end at addresses that are integer multiples of [page size - 1]. If a Page Write command attempts to write across a physical page boundary, the result is that the data wraps around to the beginning of the current page (overwriting data previously stored there), instead of being written to the next page, as might be expected. It is therefore necessary for the application software to prevent page write operations that would attempt to cross a page boundary.

**FIGURE 4-1: BYTE WRITE**

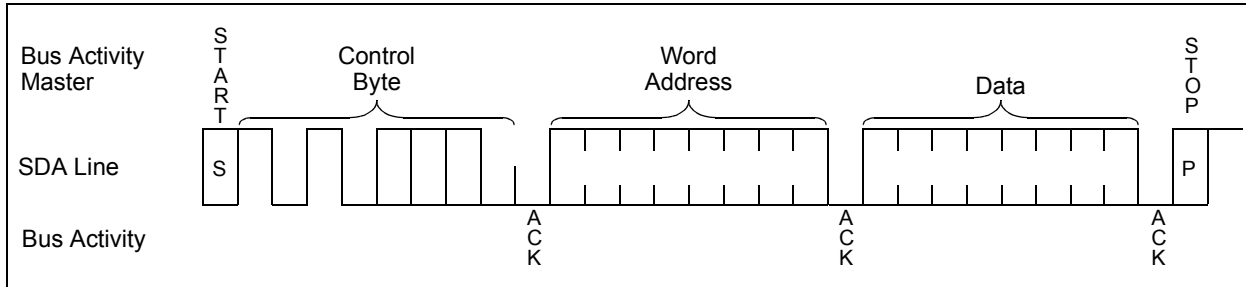

**FIGURE 4-2: PAGE WRITE**

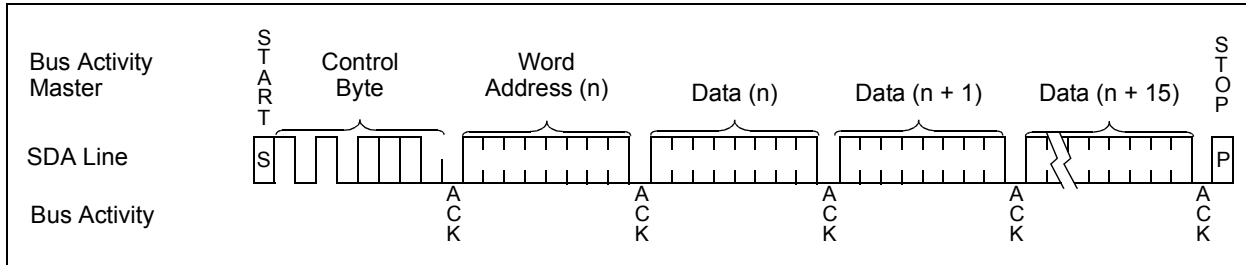

## 5.0 ACKNOWLEDGE POLLING

Since the device will not acknowledge during a write cycle, this can be used to determine when the cycle is complete (this feature can be used to maximize bus throughput). Once the Stop condition for a Write command has been issued from the master, the device initiates the internally timed write cycle. ACK polling can be initiated immediately. This involves the master sending a Start condition followed by the control byte for a Write command ( $R/\overline{W} = 0$ ). If the device is still busy with the write cycle, then no ACK will be returned. If the cycle is complete, then the device will return the ACK and the master can then proceed with the next Read or Write command. See Figure 5-1 for flow diagram.

**FIGURE 5-1: ACKNOWLEDGE POLLING FLOW**

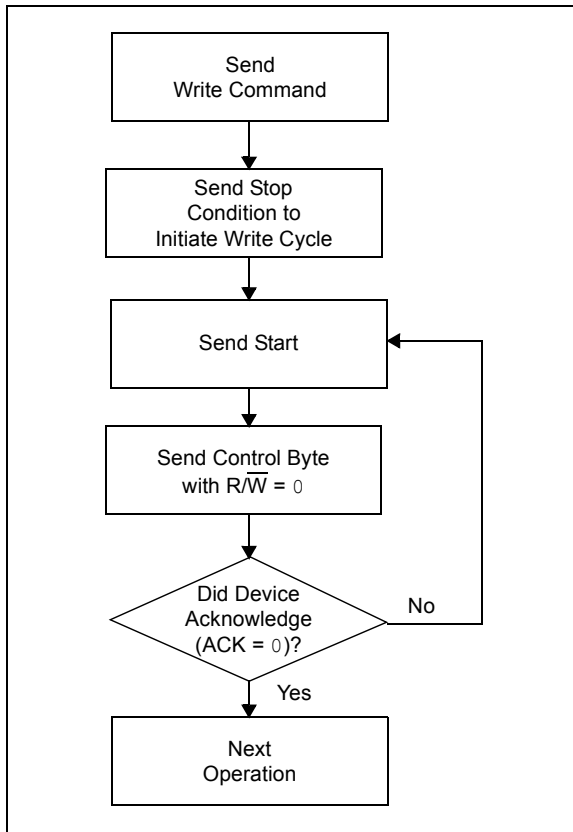

# 34VL02

## 6.0 READ OPERATION

Read operations are initiated in the same way as write operations, with the exception that the R/W bit of the slave address is set to '1'. There are three basic types of read operations: current address read, random read and sequential read.

### 6.1 Current Address Read

The 34VL02 contains an address counter that maintains the address of the last word accessed, internally incremented by '1'. Therefore, if the previous access (either a read or write operation) was to address  $n$ , the next current address read operation would access data from address  $n+1$ . Upon receipt of the slave address with R/W bit set to '1', the 34VL02 issues an acknowledge and transmits the 8-bit data word. The master will not acknowledge the transfer, but does generate a Stop condition and the 34VL02 discontinues transmission (Figure 6-1).

### 6.2 Random Read

Random read operations allow the master to access any memory location in a random manner. To perform this type of read operation, the word address must first be set. This is done by sending the word address to the 34VL02 as part of a write operation. Once the word address is sent, the master generates a Start condition following the acknowledge. This terminates the write operation, but not before the internal Address Pointer is set. The master then issues the control byte again, but with the R/W bit set to a '1'. The 34VL02 then issues an acknowledge and transmits the 8-bit data word. The master will not acknowledge the transfer, but does generate a Stop condition and the 34VL02 discontinues transmission (Figure 6-2).

### 6.3 Sequential Read

Sequential reads are initiated in the same way as a random read, with the exception that after the 34VL02 transmits the first data byte, the master issues acknowledge, as opposed to a Stop condition in a random read. This directs the 34VL02 to transmit the next sequentially addressed 8-bit word (Figure 6-3).

To provide sequential reads, the 34VL02 contains an internal Address Pointer, which is incremented by one at the completion of each operation. This Address Pointer allows the entire memory contents to be serially read during one operation.

### 6.4 Contiguous Addressing Across Multiple Devices

The Chip Select bits (A2, A1, A0) can be used to expand the contiguous address space for up to 16K bits by adding up to eight 34VL02 devices on the same bus. In this case, software can use A0 of the control byte as address bit A8; A1 as address bit A9, and A2 as address bit A10. It is not possible to sequentially read across device boundaries.

### 6.5 Noise Protection and Brown-Out

The 34VL02 employs a VCC threshold detector circuit which disables the internal erase/write logic if the VCC is below 1.35V at nominal conditions.

The SCL and SDA inputs have Schmitt Trigger and filter circuits which suppress noise spikes to assure proper device operation, even on a noisy bus.

FIGURE 6-1: CURRENT ADDRESS READ

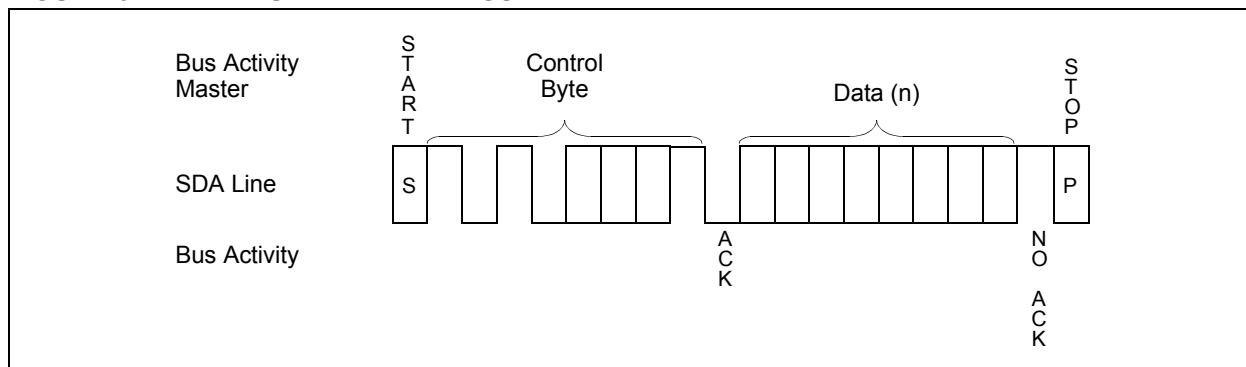

**FIGURE 6-2: RANDOM READ**

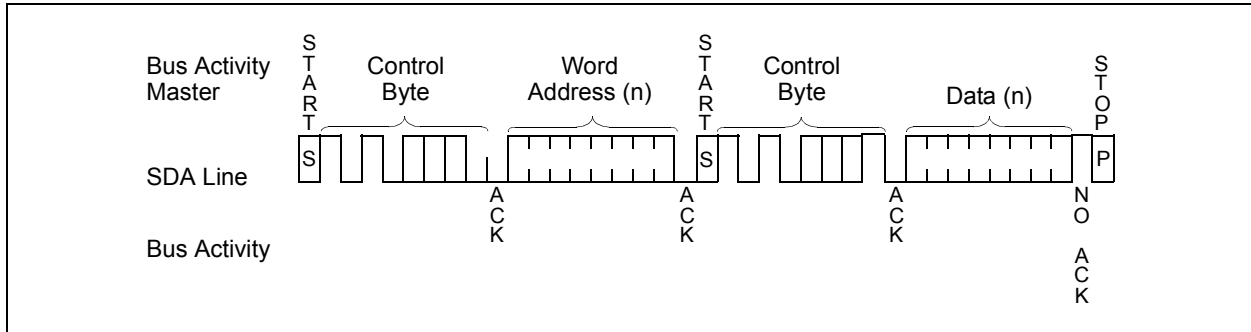

**FIGURE 6-3: SEQUENTIAL READ**

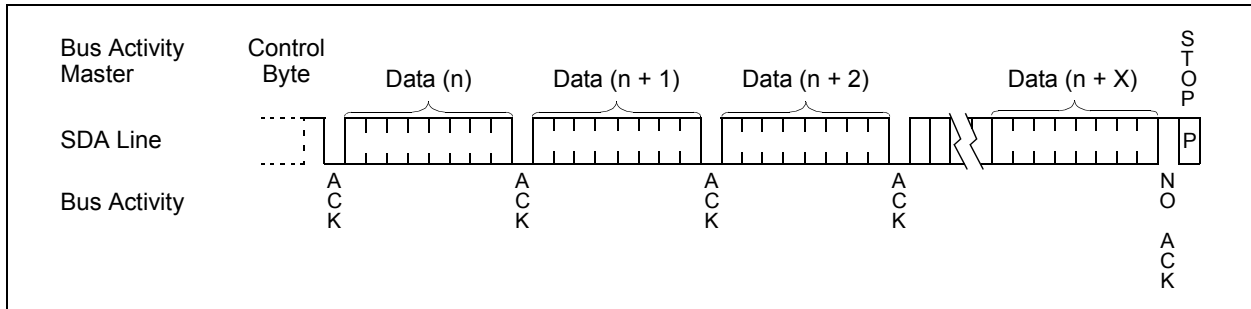

## 7.0 WRITE PROTECTION

The 34VL02 has two software write-protect features (SWP and PSWP) that allows the lower half of the array (addresses 00h-7Fh) to be write-protected, as well as a WP pin that can be used to protect the entire array. The permanent software write-protect feature is enabled by sending the device a special command. Once this feature has been enabled, it cannot be reversed. The resettable software write-protect feature is also enabled by sending the device a special command but can be reset by issuing another special command. In addition to the software protect features, there is a WP pin that can be used to write-protect the entire array, regardless of whether the software write-protect register has been written or not.

Table 7-2 and Table 7-3 describe how the 34VL02 will acknowledge specific commands under various circumstances.

### 7.1 Hardware Write Protection

The WP pin allows the user to write-protect the entire array (00-FF) when the pin is tied to VCC. If the pin is tied to Vss the write protection is disabled.

## 7.2 Software Write Protection (SWP) and Clear Software Write Protection (CSWP)

In addition to hardware write-protect the 34VL02 has an additional software write-protect feature that, when set, protects the first 128 bytes (00-7Fh) of the array from being written.

Setting the software write protection is done by sending the SWP instruction. SWP can also then be cleared by issuing a CSWP instruction (see Figure 7-1).

These two instructions follow the same format as the BYTE WRITE instruction with the exception of the Device Type Identifier, (typically '1010', instead changes to '0110'). Once this identifier is recognized by the device, the rest of the Byte Write command, address and data, are "don't cares". In addition to the identifier, high voltage must be applied to the A0 pin of the device and specific levels must be present on A1 and A2. See Table 7-1 for the available commands.

### 7.3 Permanent Software Write-Protect (PSWP)

The Permanent software write protection, or PSWP is another instruction that may be used to permanently protect the first 128 byte of the array. Once this command is issued, the user will no longer have the ability to clear this feature regardless of instruction, power cycling, or state of the WP pin. Also, once this instruction has been executed, the device will no longer acknowledge the device identifier '0110'.

**FIGURE 7-1: SOFTWARE WRITE PROTECTION FOR SWP, CSWP, PSWP, OR CPSWP**

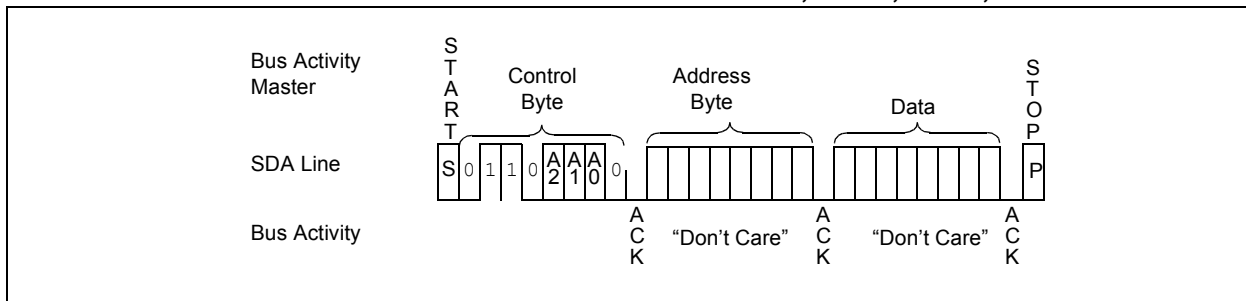

**TABLE 7-1: SOFTWARE WRITE PROTECTION INSTRUCTION SET WP = 0**

|           | Address Pins |     |     | Device Type Identifier |    |    |    | Chip Select Bits |    |    | R/W |
|-----------|--------------|-----|-----|------------------------|----|----|----|------------------|----|----|-----|
|           | A2           | A1  | A0  | B7                     | B6 | B5 | B4 | B3               | B2 | B1 | B0  |
| SWP       | Vss          | Vss | VHV | 0                      | 1  | 1  | 0  | 0                | 0  | 1  | 0   |
| CSWP      | Vss          | Vcc | VHV | 0                      | 1  | 1  | 0  | 0                | 1  | 1  | 0   |
| PSWP      | A2           | A1  | A0  | 0                      | 1  | 1  | 0  | A2               | A1 | A0 | 0   |
| Read SWP  | Vss          | Vss | VHV | 0                      | 1  | 1  | 0  | 0                | 0  | 1  | 1   |
| Read CSWP | Vss          | Vcc | VHV | 0                      | 1  | 1  | 0  | 0                | 1  | 1  | 1   |
| Read PSWP | A2           | A1  | A0  | 0                      | 1  | 1  | 0  | A2               | A1 | A0 | 1   |

1. A0 is used to detect VHV for the SWP and CSWP commands.
2. B3, B2 and B1 are compared to the A2, A1 and A0 external pins, respectively on the 34XX02.

**TABLE 7-2: ACKNOWLEDGE TABLE FOR WRITE OR WRITE PROTECTION WITH R/W = 0**

| Status                | Write-Protect | Instruction                           | ACK    | Address    | ACK    | Data Byte  | ACK    | Write Cycle |
|-----------------------|---------------|---------------------------------------|--------|------------|--------|------------|--------|-------------|
| Permanently Protected | x             | PSWP, SWP, CSWP                       | No Ack | Don't Care | No Ack | Don't Care | No Ack | No          |
|                       |               | PAGE or BYTE WRITE in lower 128 bytes | Ack    | Address    | Ack    | Data       | No Ack | No          |
| Protected with SWP    | 0             | SWP                                   | No Ack | Don't Care | No Ack | Don't Care | No Ack | No          |
|                       |               | CSWP                                  | Ack    | Don't Care | Ack    | Don't Care | Ack    | Yes         |
|                       |               | PSWP                                  | Ack    | Don't Care | Ack    | Don't Care | Ack    | Yes         |
|                       |               | PAGE or BYTE WRITE in lower 128 bytes | Ack    | Address    | Ack    | Data       | No Ack | No          |
|                       | 1             | SWP                                   | No Ack | Don't Care | No Ack | Don't Care | No Ack | No          |
|                       |               | CSWP                                  | Ack    | Don't Care | Ack    | Don't Care | No Ack | No          |
|                       |               | PSWP                                  | Ack    | Don't Care | Ack    | Don't Care | No Ack | No          |
| Not Protected         | 0             | PSWP, SWP, or CSWP                    | Ack    | Don't Care | Ack    | Don't Care | Ack    | Yes         |
|                       |               | PAGE or BYTE WRITE                    | Ack    | Address    | Ack    | Data       | Ack    | Yes         |
|                       | 1             | PSWP, SWP, or CSWP                    | Ack    | Don't Care | Ack    | Don't Care | No Ack | No          |
|                       |               | PAGE or BYTE WRITE                    | Ack    | Address    | Ack    | Address    | No Ack | No          |

**TABLE 7-3: ACKNOWLEDGE TABLE FOR WRITE OR WRITE PROTECTION WITH R/W = 1**

| Status                | Instruction     | ACK    |
|-----------------------|-----------------|--------|
| Permanently Protected | PSWP, SWP, CSWP | No Ack |
| Protected with SWP    | SWP             | No Ack |
|                       | CSWP            | Ack    |
|                       | PSWP            | Ack    |
| Not protected         | PSWP, SWP, CSWP | Ack    |

## 8.0 PIN DESCRIPTIONS

The descriptions of the pins are listed in Table 8-1.

**TABLE 8-1: PIN FUNCTION TABLE**

| Symbol | PDIP | SOIC | TSSOP | MSOP | TDFN | SOT-23 | Description                |
|--------|------|------|-------|------|------|--------|----------------------------|
| A0     | 1    | 1    | 1     | 1    | 1    | 5      | Chip Address Input         |
| A1     | 2    | 2    | 2     | 2    | 2    | 4      | Chip Address Input         |
| A2     | 3    | 3    | 3     | 3    | 3    | NC     | Chip Address Input         |
| Vss    | 4    | 4    | 4     | 4    | 4    | 2      | Ground                     |
| SDA    | 5    | 5    | 5     | 5    | 5    | 3      | Serial Address/Data I/O    |
| SCL    | 6    | 6    | 6     | 6    | 6    | 1      | Serial Clock               |
| WP     | 7    | 7    | 7     | 7    | 7    | NC     | Write-Protect Input        |
| Vcc    | 8    | 8    | 8     | 8    | 8    | 6      | +1.5V to 3.6V Power Supply |

### 8.1 A0, A1, A2

The levels on these inputs are compared with the corresponding bits in the slave address. The chip is selected if the compare is true.

Up to eight 34VL02 devices may be connected to the same bus by using different Chip Select bit combinations. These inputs must be connected to either Vss or Vcc.

The A0 pin is also used to detect VHV.

### 8.2 Serial Address/Data Input/Output (SDA)

This is a bidirectional pin used to transfer addresses and data into and data out of the device. It is an open drain terminal. Therefore, the SDA bus requires a pull-up resistor to Vcc (typical 10 k $\Omega$  for 100 kHz, 2 k $\Omega$  for 400 kHz).

For normal data transfer, SDA is allowed to change only during SCL low. Changes during SCL high are reserved for indicating the Start and Stop conditions.

### 8.3 Serial Clock (SCL)

This input is used to synchronize the data transfer to and from the device.

### 8.4 Write-Protect (WP)

This is the hardware write-protect pin. It can be tied to Vcc or Vss. If tied to Vcc, the hardware write protection is enabled. If the WP pin is tied to Vss, the hardware write protection is disabled.

## 9.0 PACKAGING INFORMATION

### 9.1 Package Marking Information

8-Lead PDIP (300 mil)

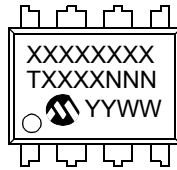

Example:

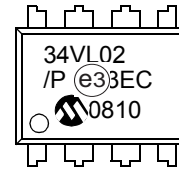

8-Lead SOIC (3.90 mm)

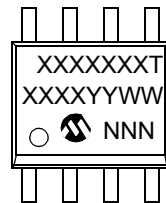

Example:

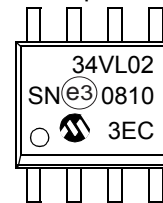

8-Lead TSSOP



Example:

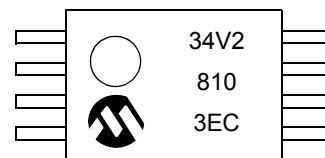

8-Lead MSOP

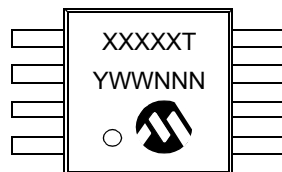

Example:

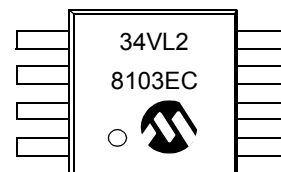

8-Lead 2x3 TDFN

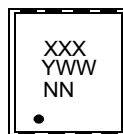

Example:

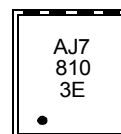

| Part Number | 1st Line Marking Codes |        |      |        |
|-------------|------------------------|--------|------|--------|
|             | TSSOP                  | MSOP   | TDFN | SOT-23 |
| 34VL02      | 34V2                   | 34VL2T | AJ7  | SMNN   |

6-Lead SOT-23

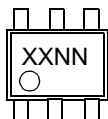

Example:

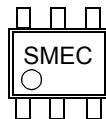

|                |        |  |
|----------------|--------|--|
| <b>Legend:</b> | XX...X | Part number or part number code                                  |
|                | T      | Temperature (I, E)   |
|                | Y      | Year code (last digit of calendar year)                          |
|                | YY     | Year code (last 2 digits of calendar year)                       |
|                | WW     | Week code (week of January 1 is week '01')                       |
|                | NNN    | Alphanumeric traceability code (2 characters for small packages) |
|                | Ⓔ3     | Pb-free JEDEC designator for Matte Tin (Sn)                      |

**Note:** For very small packages with no room for the Pb-free JEDEC designator Ⓔ3, the marking will only appear on the outer carton or reel label.

**Note:** In the event the full Microchip part number cannot be marked on one line, it will be carried over to the next line, thus limiting the number of available characters for customer-specific information.

**Note:** Please visit [www.microchip.com/Pbfree](http://www.microchip.com/Pbfree) for the latest information on Pb-free conversion.

\*Standard OTP marking consists of Microchip part number, year code, week code, and traceability code.

## 8-Lead Plastic Dual In-Line (P) – 300 mil Body [PDIP]

**Note:** For the most current package drawings, please see the Microchip Packaging Specification located at <http://www.microchip.com/packaging>

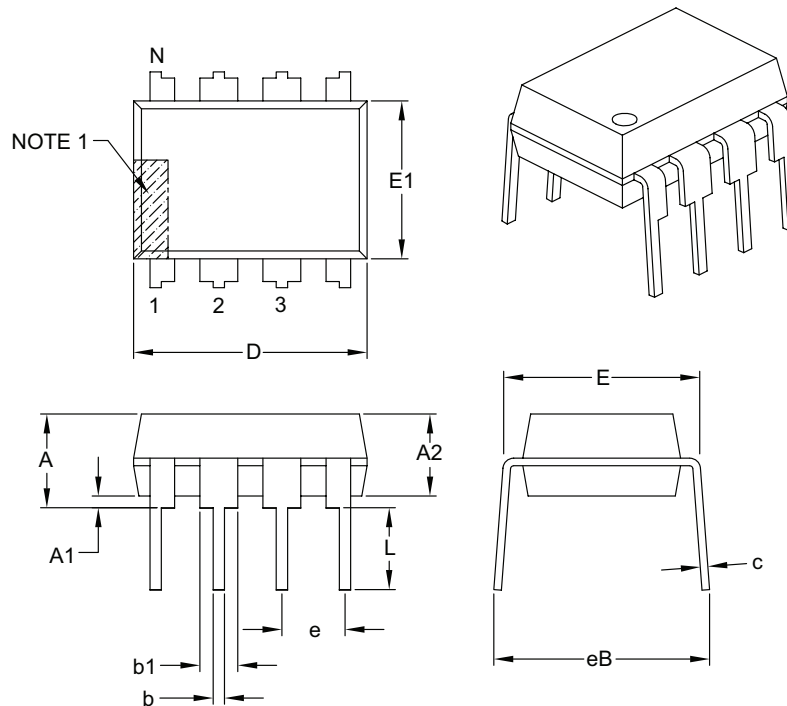

| Dimension Limits           | Units | INCHES   |      |      |
|----------------------------|-------|----------|------|------|
|                            |       | MIN      | NOM  | MAX  |
| Number of Pins             | N     | 8        |      |      |
| Pitch                      | e     | .100 BSC |      |      |
| Top to Seating Plane       | A     | –        | –    | .210 |
| Molded Package Thickness   | A2    | .115     | .130 | .195 |
| Base to Seating Plane      | A1    | .015     | –    | –    |
| Shoulder to Shoulder Width | E     | .290     | .310 | .325 |
| Molded Package Width       | E1    | .240     | .250 | .280 |
| Overall Length             | D     | .348     | .365 | .400 |
| Tip to Seating Plane       | L     | .115     | .130 | .150 |
| Lead Thickness             | c     | .008     | .010 | .015 |
| Upper Lead Width           | b1    | .040     | .060 | .070 |
| Lower Lead Width           | b     | .014     | .018 | .022 |
| Overall Row Spacing §      | eB    | –        | –    | .430 |

**Notes:**

1. Pin 1 visual index feature may vary, but must be located with the hatched area.
2. § Significant Characteristic.
3. Dimensions D and E1 do not include mold flash or protrusions. Mold flash or protrusions shall not exceed .010" per side.
4. Dimensioning and tolerancing per ASME Y14.5M.

BSC: Basic Dimension. Theoretically exact value shown without tolerances.

Microchip Technology Drawing C04-018B

# 34VL02

## 8-Lead Plastic Small Outline (SN) – Narrow, 3.90 mm Body [SOIC]

**Note:** For the most current package drawings, please see the Microchip Packaging Specification located at <http://www.microchip.com/packaging>

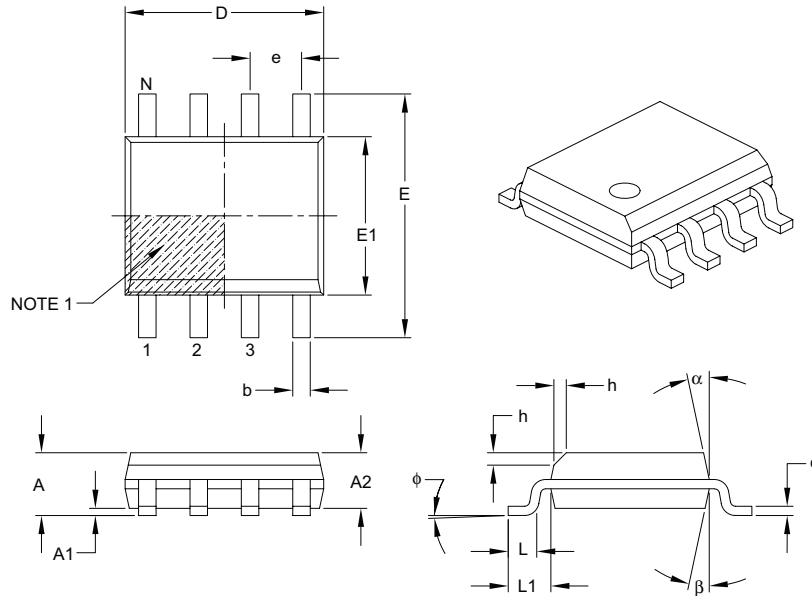

| Dimension Limits         |    | Units | MILLIMETERS |     |      |
|--------------------------|----|-------|-------------|-----|------|
|                          |    |       | MIN         | NOM | MAX  |
| Number of Pins           | N  |       | 8           |     |      |
| Pitch                    | e  |       | 1.27 BSC    |     |      |
| Overall Height           | A  |       | –           | –   | 1.75 |
| Molded Package Thickness | A2 |       | 1.25        | –   | –    |
| Standoff §               | A1 |       | 0.10        | –   | 0.25 |
| Overall Width            | E  |       | 6.00 BSC    |     |      |
| Molded Package Width     | E1 |       | 3.90 BSC    |     |      |
| Overall Length           | D  |       | 4.90 BSC    |     |      |
| Chamfer (optional)       | h  |       | 0.25        | –   | 0.50 |
| Foot Length              | L  |       | 0.40        | –   | 1.27 |
| Footprint                | L1 |       | 1.04 REF    |     |      |
| Foot Angle               | φ  |       | 0°          | –   | 8°   |
| Lead Thickness           | c  |       | 0.17        | –   | 0.25 |
| Lead Width               | b  |       | 0.31        | –   | 0.51 |
| Mold Draft Angle Top     | α  |       | 5°          | –   | 15°  |
| Mold Draft Angle Bottom  | β  |       | 5°          | –   | 15°  |

**Notes:**

1. Pin 1 visual index feature may vary, but must be located within the hatched area.
2. § Significant Characteristic.
3. Dimensions D and E1 do not include mold flash or protrusions. Mold flash or protrusions shall not exceed 0.15 mm per side.
4. Dimensioning and tolerancing per ASME Y14.5M.

BSC: Basic Dimension. Theoretically exact value shown without tolerances.

REF: Reference Dimension, usually without tolerance, for information purposes only.

Microchip Technology Drawing C04-057B

## 8-Lead Plastic Small Outline (SN) – Narrow, 3.90 mm Body [SOIC]

**Note:** For the most current package drawings, please see the Microchip Packaging Specification located at <http://www.microchip.com/packaging>

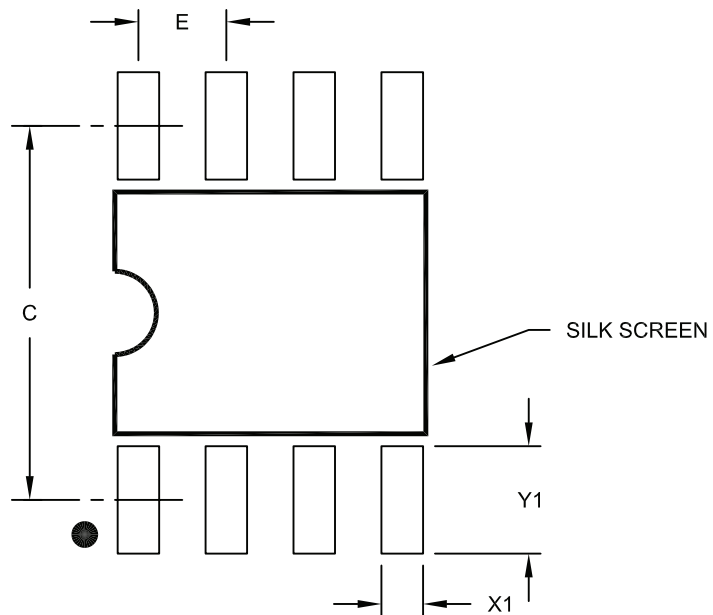

RECOMMENDED LAND PATTERN

| Dimension Limits        | Units | MILLIMETERS |      |      |
|-------------------------|-------|-------------|------|------|
|                         |       | MIN         | NOM  | MAX  |
| Contact Pitch           | E     | 1.27 BSC    |      |      |
| Contact Pad Spacing     | C     |             | 5.40 |      |
| Contact Pad Width (X8)  | X1    |             |      | 0.60 |
| Contact Pad Length (X8) | Y1    |             |      | 1.55 |

**Notes:**

1. Dimensioning and tolerancing per ASME Y14.5M

BSC: Basic Dimension. Theoretically exact value shown without tolerances.

Microchip Technology Drawing No. C04-2057A

## 8-Lead Plastic Thin Shrink Small Outline (ST) – 4.4 mm Body [TSSOP]

**Note:** For the most current package drawings, please see the Microchip Packaging Specification located at <http://www.microchip.com/packaging>

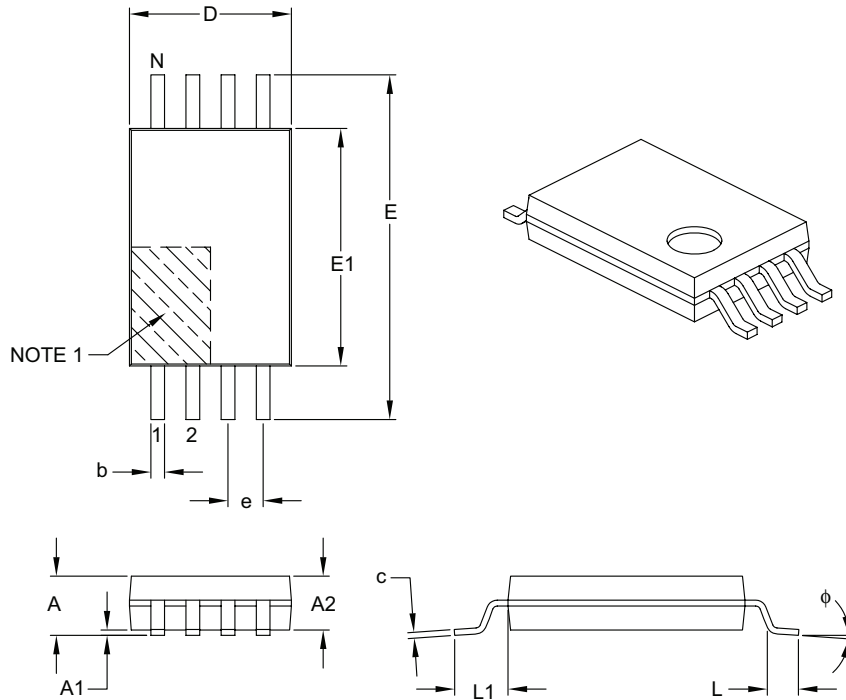

| Dimension Limits         | Units  | MILLIMETERS |      |      |
|--------------------------|--------|-------------|------|------|
|                          |        | MIN         | NOM  | MAX  |
| Number of Pins           | N      | 8           |      |      |
| Pitch                    | e      | 0.65 BSC    |      |      |
| Overall Height           | A      | –           | –    | 1.20 |
| Molded Package Thickness | A2     | 0.80        | 1.00 | 1.05 |
| Standoff                 | A1     | 0.05        | –    | 0.15 |
| Overall Width            | E      | 6.40 BSC    |      |      |
| Molded Package Width     | E1     | 4.30        | 4.40 | 4.50 |
| Molded Package Length    | D      | 2.90        | 3.00 | 3.10 |
| Foot Length              | L      | 0.45        | 0.60 | 0.75 |
| Footprint                | L1     | 1.00 REF    |      |      |
| Foot Angle               | $\phi$ | 0°          | –    | 8°   |
| Lead Thickness           | c      | 0.09        | –    | 0.20 |
| Lead Width               | b      | 0.19        | –    | 0.30 |

**Notes:**

- Pin 1 visual index feature may vary, but must be located within the hatched area.
- Dimensions D and E1 do not include mold flash or protrusions. Mold flash or protrusions shall not exceed 0.15 mm per side.
- Dimensioning and tolerancing per ASME Y14.5M.

BSC: Basic Dimension. Theoretically exact value shown without tolerances.

REF: Reference Dimension, usually without tolerance, for information purposes only.

Microchip Technology Drawing C04-086B

## 8-Lead Plastic Micro Small Outline Package (MS) [MSOP]

**Note:** For the most current package drawings, please see the Microchip Packaging Specification located at <http://www.microchip.com/packaging>

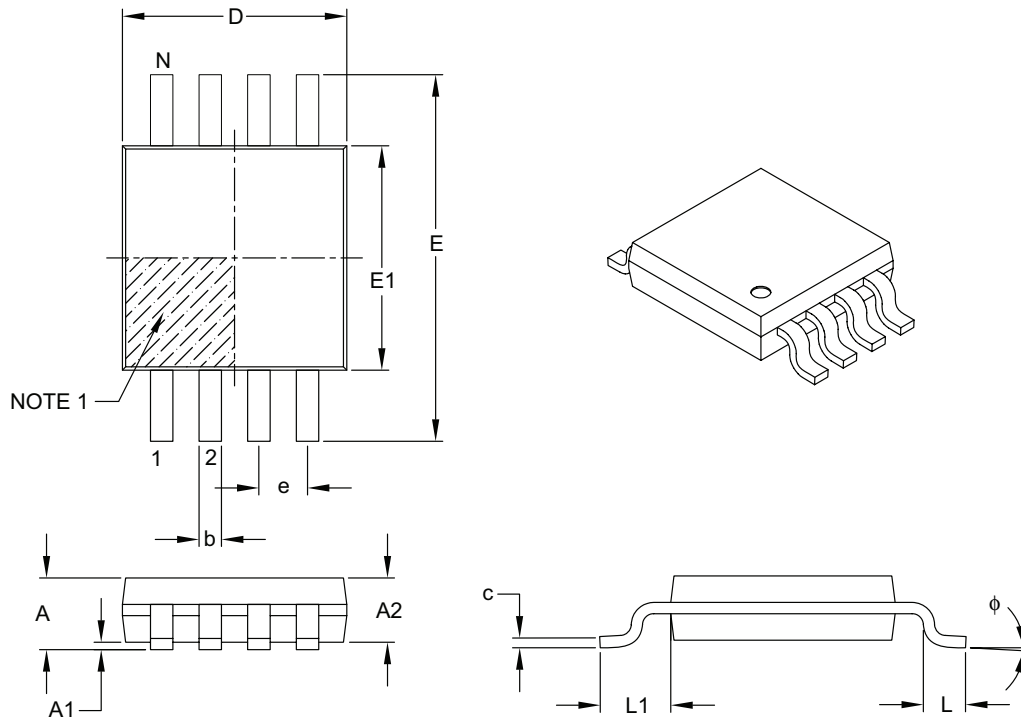

| Dimension Limits         | Units  | MILLIMETERS |      |      |
|--------------------------|--------|-------------|------|------|
|                          |        | MIN         | NOM  | MAX  |
| Number of Pins           | N      | 8           |      |      |
| Pitch                    | e      | 0.65 BSC    |      |      |
| Overall Height           | A      | –           | –    | 1.10 |
| Molded Package Thickness | A2     | 0.75        | 0.85 | 0.95 |
| Standoff                 | A1     | 0.00        | –    | 0.15 |
| Overall Width            | E      | 4.90 BSC    |      |      |
| Molded Package Width     | E1     | 3.00 BSC    |      |      |
| Overall Length           | D      | 3.00 BSC    |      |      |
| Foot Length              | L      | 0.40        | 0.60 | 0.80 |
| Footprint                | L1     | 0.95 REF    |      |      |
| Foot Angle               | $\phi$ | 0°          | –    | 8°   |
| Lead Thickness           | c      | 0.08        | –    | 0.23 |
| Lead Width               | b      | 0.22        | –    | 0.40 |

**Notes:**

1. Pin 1 visual index feature may vary, but must be located within the hatched area.
2. Dimensions D and E1 do not include mold flash or protrusions. Mold flash or protrusions shall not exceed 0.15 mm per side.
3. Dimensioning and tolerancing per ASME Y14.5M.

BSC: Basic Dimension. Theoretically exact value shown without tolerances.

REF: Reference Dimension, usually without tolerance, for information purposes only.

Microchip Technology Drawing C04-111B

# 34VL02

## 8-Lead Plastic Dual Flat, No Lead Package (MN) – 2x3x0.75 mm Body [TDFN]

**Note:** For the most current package drawings, please see the Microchip Packaging Specification located at <http://www.microchip.com/packaging>

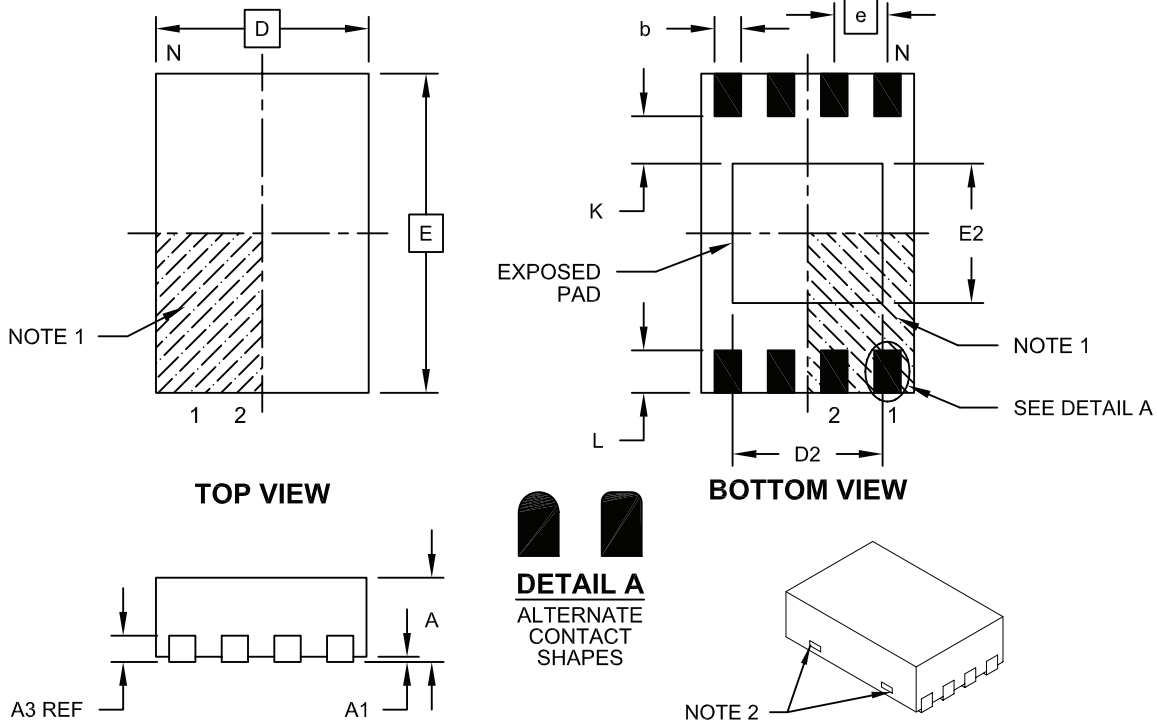

| Dimension              | Units | MILLIMETERS |      |      |
|------------------------|-------|-------------|------|------|
|                        |       | MIN         | NOM  | MAX  |
| Number of Pins         | N     | 8           |      |      |
| Pitch                  | e     | 0.50 BSC    |      |      |
| Overall Height         | A     | 0.70        | 0.75 | 0.80 |
| Standoff               | A1    | 0.00        | 0.02 | 0.05 |
| Contact Thickness      | A3    | 0.20 REF    |      |      |
| Overall Length         | D     | 2.00 BSC    |      |      |
| Overall Width          | E     | 3.00 BSC    |      |      |
| Exposed Pad Length     | D2    | 1.20        | -    | 1.60 |
| Exposed Pad Width      | E2    | 1.20        | -    | 1.60 |
| Contact Width          | b     | 0.20        | 0.25 | 0.30 |
| Contact Length         | L     | 0.25        | 0.30 | 0.45 |
| Contact-to-Exposed Pad | K     | 0.20        | -    | -    |

**Notes:**

- Pin 1 visual index feature may vary, but must be located within the hatched area.
- Package may have one or more exposed tie bars at ends.
- Package is saw singulated
- Dimensioning and tolerancing per ASME Y14.5M

BSC: Basic Dimension. Theoretically exact value shown without tolerances.

REF: Reference Dimension, usually without tolerance, for information purposes only.

Microchip Technology Drawing No. C04-129B

## 8-Lead Plastic Dual Flat, No Lead Package (MN) – 2x3x0.75 mm Body [TDFN]

**Note:** For the most current package drawings, please see the Microchip Packaging Specification located at <http://www.microchip.com/packaging>

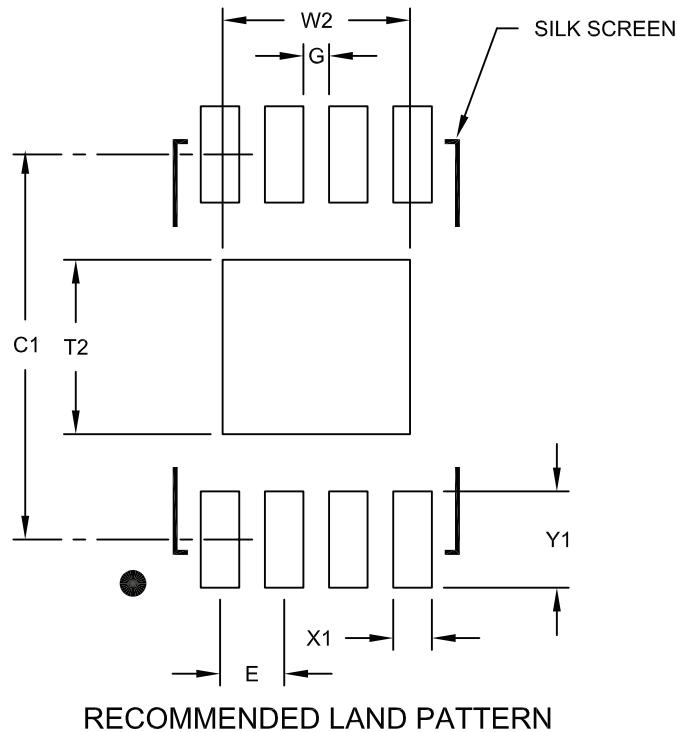

|                            |                  | MILLIMETERS |      |      |
|----------------------------|------------------|-------------|------|------|
|                            |                  | MIN         | NOM  | MAX  |
|                            | Units            |             |      |      |
|                            | Dimension Limits |             |      |      |
| Contact Pitch              | E                | 0.50 BSC    |      |      |
| Optional Center Pad Width  | W2               |             |      | 1.46 |
| Optional Center Pad Length | T2               |             |      | 1.36 |
| Contact Pad Spacing        | C1               |             | 3.00 |      |
| Contact Pad Width (X8)     | X1               |             |      | 0.30 |
| Contact Pad Length (X8)    | Y1               |             |      | 0.75 |
| Distance Between Pads      | G                | 0.20        |      |      |

**Notes:**

1. Dimensioning and tolerancing per ASME Y14.5M

BSC: Basic Dimension. Theoretically exact value shown without tolerances.

Microchip Technology Drawing No. C04-2129A

# 34VL02

## 6-Lead Plastic Small Outline Transistor (OT) [SOT-23]

**Note:** For the most current package drawings, please see the Microchip Packaging Specification located at <http://www.microchip.com/packaging>

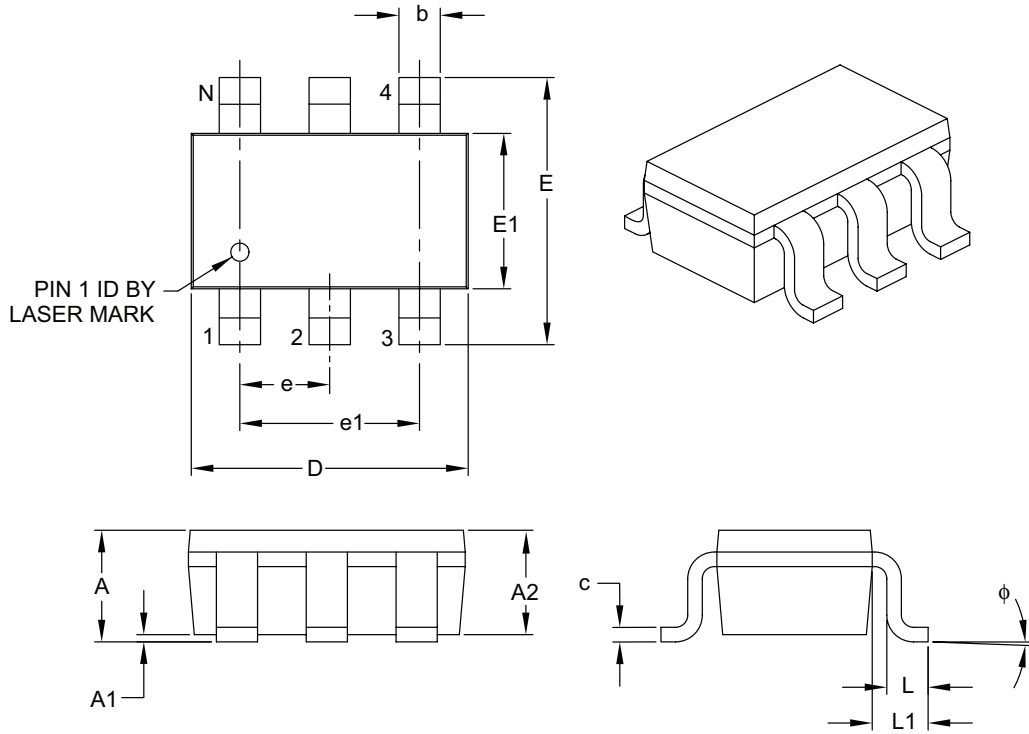

| Dimension Limits         | Units  | MILLIMETERS |     |      |
|--------------------------|--------|-------------|-----|------|
|                          |        | MIN         | NOM | MAX  |
| Number of Pins           | N      | 6           |     |      |
| Pitch                    | e      | 0.95 BSC    |     |      |
| Outside Lead Pitch       | e1     | 1.90 BSC    |     |      |
| Overall Height           | A      | 0.90        | -   | 1.45 |
| Molded Package Thickness | A2     | 0.89        | -   | 1.30 |
| Standoff                 | A1     | 0.00        | -   | 0.15 |
| Overall Width            | E      | 2.20        | -   | 3.20 |
| Molded Package Width     | E1     | 1.30        | -   | 1.80 |
| Overall Length           | D      | 2.70        | -   | 3.10 |
| Foot Length              | L      | 0.10        | -   | 0.60 |
| Footprint                | L1     | 0.35        | -   | 0.80 |
| Foot Angle               | $\phi$ | 0°          | -   | 30°  |
| Lead Thickness           | c      | 0.08        | -   | 0.26 |
| Lead Width               | b      | 0.20        | -   | 0.51 |

**Notes:**

- Dimensions D and E1 do not include mold flash or protrusions. Mold flash or protrusions shall not exceed 0.127 mm per side.
- Dimensioning and tolerancing per ASME Y14.5M.

BSC: Basic Dimension. Theoretically exact value shown without tolerances.

Microchip Technology Drawing C04-028B

## APPENDIX A: REVISION HISTORY

### Revision A (3/2008)

Original release of this document.

# 34VL02

---

NOTES:

## THE MICROCHIP WEB SITE

Microchip provides online support via our WWW site at [www.microchip.com](http://www.microchip.com). This web site is used as a means to make files and information easily available to customers. Accessible by using your favorite Internet browser, the web site contains the following information:

- **Product Support** – Data sheets and errata, application notes and sample programs, design resources, user's guides and hardware support documents, latest software releases and archived software
- **General Technical Support** – Frequently Asked Questions (FAQ), technical support requests, online discussion groups, Microchip consultant program member listing
- **Business of Microchip** – Product selector and ordering guides, latest Microchip press releases, listing of seminars and events, listings of Microchip sales offices, distributors and factory representatives

## CUSTOMER CHANGE NOTIFICATION SERVICE

Microchip's customer notification service helps keep customers current on Microchip products. Subscribers will receive e-mail notification whenever there are changes, updates, revisions or errata related to a specified product family or development tool of interest.

To register, access the Microchip web site at [www.microchip.com](http://www.microchip.com), click on Customer Change Notification and follow the registration instructions.

## CUSTOMER SUPPORT

Users of Microchip products can receive assistance through several channels:

- Distributor or Representative
- Local Sales Office
- Field Application Engineer (FAE)
- Technical Support
- Development Systems Information Line

Customers should contact their distributor, representative or field application engineer (FAE) for support. Local sales offices are also available to help customers. A listing of sales offices and locations is included in the back of this document.

**Technical support is available through the web site at: <http://support.microchip.com>**

# 34VL02

---

## READER RESPONSE

It is our intention to provide you with the best documentation possible to ensure successful use of your Microchip product. If you wish to provide your comments on organization, clarity, subject matter, and ways in which our documentation can better serve you, please FAX your comments to the Technical Publications Manager at (480) 792-4150.

Please list the following information, and use this outline to provide us with your comments about this document.

To: Technical Publications Manager  
RE: Reader Response  
Total Pages Sent \_\_\_\_\_

From: Name \_\_\_\_\_  
Company \_\_\_\_\_  
Address \_\_\_\_\_  
City / State / ZIP / Country \_\_\_\_\_  
Telephone: (\_\_\_\_\_) \_\_\_\_\_ - \_\_\_\_\_ FAX: (\_\_\_\_\_) \_\_\_\_\_ - \_\_\_\_\_

Application (optional):

Would you like a reply? \_\_\_Y \_\_\_N

Device: 34VL02

Literature Number: DS22079A

Questions:

1. What are the best features of this document?

---

---

2. How does this document meet your hardware and software development needs?

---

---

3. Do you find the organization of this document easy to follow? If not, why?

---

---

4. What additions to the document do you think would enhance the structure and subject?

---

---

5. What deletions from the document could be made without affecting the overall usefulness?

---

---

6. Is there any incorrect or misleading information (what and where)?

---

---

7. How would you improve this document?

---

---

## PRODUCT IDENTIFICATION SYSTEM

To order or obtain information, e.g., on pricing or delivery, refer to the factory or the listed sales office.

| PART NO.   |                   | X   | XX      |
|--|-------------------|---|---------|
| Device   | Temperature Range |   | Package |
| <p><b>Device:</b></p> <p>34VL02: = 1.5V, 2 Kbit I<sup>2</sup>C Serial EEPROM<br/>           34VL02T: = 1.5V, 2 Kbit I<sup>2</sup>C Serial EEPROM (Tape and Reel)</p>   |                   |   |         |
| <p><b>Temperature Range:</b></p> <p>Blank = -20°C to +85°C</p>   |                   |   |         |
| <p><b>Package:</b></p> <p>OT = Plastic Small Outline (SOT-23), 6-lead<br/>           P = Plastic DIP (300 mil body), 8-lead<br/>           SN = Plastic SOIC (3.90 mm body), 8-lead<br/>           ST = Plastic TSSOP (4.4 mm), 8-lead<br/>           MS = Plastic Micro Small Outline (MSOP), 8-lead<br/>           MNY* = Plastic Dual Flat (TDFN), no lead package, 2x3 mm body, 8-lead</p> |                   |   |         |
| <p><b>Note 1:</b> "Y" indicates a Nickel Palladium Gold (NiPdAu) finish.</p>   |                   |   |         |
|  |                   | <p><b>Examples:</b></p> <p>a) 34VL02T/OT: Tape and Reel, 1.5V, SOT-23 package<br/>           b) 34VL02T/ST: Tape and Reel, 1.5V, TSSOP package<br/>           c) 34VL02T/MNY: Tape and Reel, 1.5V, TDFN package</p> |         |

# 34VL02

---

NOTES:

---

**Note the following details of the code protection feature on Microchip devices:**

- Microchip products meet the specification contained in their particular Microchip Data Sheet.
- Microchip believes that its family of products is one of the most secure families of its kind on the market today, when used in the intended manner and under normal conditions.
- There are dishonest and possibly illegal methods used to breach the code protection feature. All of these methods, to our knowledge, require using the Microchip products in a manner outside the operating specifications contained in Microchip's Data Sheets. Most likely, the person doing so is engaged in theft of intellectual property.
- Microchip is willing to work with the customer who is concerned about the integrity of their code.
- Neither Microchip nor any other semiconductor manufacturer can guarantee the security of their code. Code protection does not mean that we are guaranteeing the product as "unbreakable."

Code protection is constantly evolving. We at Microchip are committed to continuously improving the code protection features of our products. Attempts to break Microchip's code protection feature may be a violation of the Digital Millennium Copyright Act. If such acts allow unauthorized access to your software or other copyrighted work, you may have a right to sue for relief under that Act.

---

Information contained in this publication regarding device applications and the like is provided only for your convenience and may be superseded by updates. It is your responsibility to ensure that your application meets with your specifications. MICROCHIP MAKES NO REPRESENTATIONS OR WARRANTIES OF ANY KIND WHETHER EXPRESS OR IMPLIED, WRITTEN OR ORAL, STATUTORY OR OTHERWISE, RELATED TO THE INFORMATION, INCLUDING BUT NOT LIMITED TO ITS CONDITION, QUALITY, PERFORMANCE, MERCHANTABILITY OR FITNESS FOR PURPOSE. Microchip disclaims all liability arising from this information and its use. Use of Microchip devices in life support and/or safety applications is entirely at the buyer's risk, and the buyer agrees to defend, indemnify and hold harmless Microchip from any and all damages, claims, suits, or expenses resulting from such use. No licenses are conveyed, implicitly or otherwise, under any Microchip intellectual property rights.

**Trademarks**

The Microchip name and logo, the Microchip logo, Accuron, dsPIC, KEELOQ, KEELOQ logo, MPLAB, PIC, PICmicro, PICSTART, PRO MATE, rPIC and SmartShunt are registered trademarks of Microchip Technology Incorporated in the U.S.A. and other countries.

FilterLab, Linear Active Thermistor, MXDEV, MXLAB, SEEVAL, SmartSensor and The Embedded Control Solutions Company are registered trademarks of Microchip Technology Incorporated in the U.S.A.

Analog-for-the-Digital Age, Application Maestro, CodeGuard, dsPICDEM, dsPICDEM.net, dsPICworks, dsSPEAK, ECAN, ECONOMONITOR, FanSense, In-Circuit Serial Programming, ICSP, ICEPIC, Mindi, MiWi, MPASM, MPLAB Certified logo, MPLIB, MPLINK, mTouch, PICkit, PICDEM, PICDEM.net, PICtail, PIC<sup>32</sup> logo, PowerCal, PowerInfo, PowerMate, PowerTool, REAL ICE, rLAB, Select Mode, Total Endurance, UNI/O, WiperLock and ZENA are trademarks of Microchip Technology Incorporated in the U.S.A. and other countries.

SQTP is a service mark of Microchip Technology Incorporated in the U.S.A.

All other trademarks mentioned herein are property of their respective companies.

© 2008, Microchip Technology Incorporated, Printed in the U.S.A., All Rights Reserved.

 Printed on recycled paper.

**QUALITY MANAGEMENT SYSTEM  
CERTIFIED BY DNV  
== ISO/TS 16949:2002 ==**

*Microchip received ISO/TS-16949:2002 certification for its worldwide headquarters, design and wafer fabrication facilities in Chandler and Tempe, Arizona; Gresham, Oregon and design centers in California and India. The Company's quality system processes and procedures are for its PIC® MCUs and dsPIC® DSCs, KEELOQ® code hopping devices, Serial EEPROMs, microperipherals, nonvolatile memory and analog products. In addition, Microchip's quality system for the design and manufacture of development systems is ISO 9001:2000 certified.*



---

---

## WORLDWIDE SALES AND SERVICE

---

---

### AMERICAS

**Corporate Office**  
2355 West Chandler Blvd.  
Chandler, AZ 85224-6199  
Tel: 480-792-7200  
Fax: 480-792-7277  
Technical Support:  
<http://support.microchip.com>  
Web Address:  
[www.microchip.com](http://www.microchip.com)

#### Atlanta

Duluth, GA  
Tel: 678-957-9614  
Fax: 678-957-1455

#### Boston

Westborough, MA  
Tel: 774-760-0087  
Fax: 774-760-0088

#### Chicago

Itasca, IL  
Tel: 630-285-0071  
Fax: 630-285-0075

#### Dallas

Addison, TX  
Tel: 972-818-7423  
Fax: 972-818-2924

#### Detroit

Farmington Hills, MI  
Tel: 248-538-2250  
Fax: 248-538-2260

#### Kokomo

Kokomo, IN  
Tel: 765-864-8360  
Fax: 765-864-8387

#### Los Angeles

Mission Viejo, CA  
Tel: 949-462-9523  
Fax: 949-462-9608

#### Santa Clara

Santa Clara, CA  
Tel: 408-961-6444  
Fax: 408-961-6445

#### Toronto

Mississauga, Ontario,  
Canada  
Tel: 905-673-0699  
Fax: 905-673-6509

### ASIA/PACIFIC

**Asia Pacific Office**  
Suites 3707-14, 37th Floor  
Tower 6, The Gateway  
Harbour City, Kowloon  
Hong Kong  
Tel: 852-2401-1200  
Fax: 852-2401-3431

**Australia - Sydney**  
Tel: 61-2-9868-6733  
Fax: 61-2-9868-6755

**China - Beijing**  
Tel: 86-10-8528-2100  
Fax: 86-10-8528-2104

**China - Chengdu**  
Tel: 86-28-8665-5511  
Fax: 86-28-8665-7889

**China - Hong Kong SAR**  
Tel: 852-2401-1200  
Fax: 852-2401-3431

**China - Nanjing**  
Tel: 86-25-8473-2460  
Fax: 86-25-8473-2470

**China - Qingdao**  
Tel: 86-532-8502-7355  
Fax: 86-532-8502-7205

**China - Shanghai**  
Tel: 86-21-5407-5533  
Fax: 86-21-5407-5066

**China - Shenyang**  
Tel: 86-24-2334-2829  
Fax: 86-24-2334-2393

**China - Shenzhen**  
Tel: 86-755-8203-2660  
Fax: 86-755-8203-1760

**China - Wuhan**  
Tel: 86-27-5980-5300  
Fax: 86-27-5980-5118

**China - Xiamen**  
Tel: 86-592-2388138  
Fax: 86-592-2388130

**China - Xian**  
Tel: 86-29-8833-7252  
Fax: 86-29-8833-7256

**China - Zhuhai**  
Tel: 86-756-3210040  
Fax: 86-756-3210049

### ASIA/PACIFIC

**India - Bangalore**  
Tel: 91-80-4182-8400  
Fax: 91-80-4182-8422

**India - New Delhi**  
Tel: 91-11-4160-8631  
Fax: 91-11-4160-8632

**India - Pune**  
Tel: 91-20-2566-1512  
Fax: 91-20-2566-1513

**Japan - Yokohama**  
Tel: 81-45-471- 6166  
Fax: 81-45-471-6122

**Korea - Daegu**  
Tel: 82-53-744-4301  
Fax: 82-53-744-4302

**Korea - Seoul**  
Tel: 82-2-554-7200  
Fax: 82-2-558-5932 or  
82-2-558-5934

**Malaysia - Kuala Lumpur**  
Tel: 60-3-6201-9857  
Fax: 60-3-6201-9859

**Malaysia - Penang**  
Tel: 60-4-227-8870  
Fax: 60-4-227-4068

**Philippines - Manila**  
Tel: 63-2-634-9065  
Fax: 63-2-634-9069

**Singapore**  
Tel: 65-6334-8870  
Fax: 65-6334-8850

**Taiwan - Hsin Chu**  
Tel: 886-3-572-9526  
Fax: 886-3-572-6459

**Taiwan - Kaohsiung**  
Tel: 886-7-536-4818  
Fax: 886-7-536-4803

**Taiwan - Taipei**  
Tel: 886-2-2500-6610  
Fax: 886-2-2508-0102

**Thailand - Bangkok**  
Tel: 66-2-694-1351  
Fax: 66-2-694-1350

### EUROPE

**Austria - Wels**  
Tel: 43-7242-2244-39  
Fax: 43-7242-2244-393

**Denmark - Copenhagen**  
Tel: 45-4450-2828  
Fax: 45-4485-2829

**France - Paris**  
Tel: 33-1-69-53-63-20  
Fax: 33-1-69-30-90-79

**Germany - Munich**  
Tel: 49-89-627-144-0  
Fax: 49-89-627-144-44

**Italy - Milan**  
Tel: 39-0331-742611  
Fax: 39-0331-466781

**Netherlands - Drunen**  
Tel: 31-416-690399  
Fax: 31-416-690340

**Spain - Madrid**  
Tel: 34-91-708-08-90  
Fax: 34-91-708-08-91

**UK - Wokingham**  
Tel: 44-118-921-5869  
Fax: 44-118-921-5820

## Looking for pricing, stock, or lifecycle information?

Click below to explore more details on WIN SOURCE:

- ⊖ [View 34VL02T/OT on WIN SOURCE](#)
- ⊖ [Microchip Technology](#) Information

## Optimize Your Supply Chain with WIN SOURCE Solutions

- ✓ Global Sourcing Solution
- ✓ Obsolete Management
- ✓ Cost Control Management
- ✓ Shortage Management
- ✓ Alternative Solution
- ✓ Excess Inventory Management