

OVM7692 640 x 480 CameraCubeChip™ product brief



Feature-Rich VGA CameraCubeChip™ for Mobile and Picture Phone Applications



available in
a lead-free
package

The OVM7692 VGA CameraCubeChip delivers proven performance and an extended feature set in an ultra-compact size to meet the performance and manufacturing requirements for a new generation of mobile and picture phones. The CameraCubeChip is a complete VGA camera solution with DVP parallel or MIPI serial interface support and automatic luminance detection.

Featuring OmniVision's proprietary OmniPixel3-HS™ architecture, the OVM7692 delivers industry leading low-light sensitivity of 960 mV/lux-sec. The image sensor's compact size is a critical characteristic for slim camera phones where the camera can be no thicker than the LCD housing.

The complete camera solution offered by the OVM7692 significantly simplifies design, integration and manufacturing, making it easier and cheaper to source. It is designed to withstand multiple reflows during rework or dual-sided reflow to meet the stringent requirements of all handset manufacturers.

The OVM7692 CameraCubeChip comes in a 1/13-inch optical format, offering automatic exposure control (AEC), automatic gain control (AGC), automatic 50/60 Hz luminance detection and automatic black level calibration (ABLC). It supports horizontal and vertical sub-sampling, mirror, flip, scaling, and windowing. The following image quality controls are included: color saturation, hue, gamma, sharpness (edge enhancement), lens correction, defective pixel canceling and noise canceling, as well as support for black sun cancellation. The OVM7692 can interface via DVP parallel output, MIPI serial output or SCCB, and has a programmable I/O drive capability and on-chip phase lock loop. Offering low power consumption, the OVM7692 has a 2.8V power supply and a built-in 1.5V regulator for sensor core power.

Find out more at www.ovt.com.

Applications

- Cellular and Picture Phones

Product Features

- OmniPixel3-HS structure using 0.11 μm process
- optical size of 1/13"
- automatic/manual control of automatic exposure control (AEC), automatic gain control (AGC), automatic 50/60 Hz luminance detection and automatic black level calibration (ABLC)
- support for horizontal and vertical sub-sampling
- mirror, flip, scaling, windowing
- image quality controls: color saturation, hue, gamma, sharpness (edge enhancement), lens correction, defective pixel canceling, and noise canceling
- programmable gamma correction
- support for black sun cancellation
- digital video port (DVP) parallel output interface
- MIPI serial output interface
- serial camera control bus (SCCB) interface
- programmable I/O drive capability
- on-chip phase lock loop (PLL)
- 2.8V power supply
- built-in 1.5V regulator for sensor core power
- low power consumption

OVM7692



Ordering Information

- OVM7692-RYAA** (color, lead-free, CameraCubeChip™ with metal can)
- OVM7692-RAAA** (color, lead-free, CameraCubeChip™ with black coating)
- OVM7692-RYCA** (color, lead-free, CameraCubeChip™ with metal can)
- OVM7692-RACA** (color, lead-free, CameraCubeChip™ with black coating)

Product Specifications

- active array size:** 640 x 480
- power supply:**
 - analog: 2.6 - 3.0V
 - I/O: 1.7 - 3.0V
- power requirements:**
 - active: 120 mW @ AVDD = 2.8V, DOVDD = 1.8V
 - standby: 23 μA
- temperature range:**
 - operating: -30°C to 70°C junction temperature
 - stable image: 0°C to 50°C junction temperature
- output formats:** RAW 8-bit, RAW 10-bit (for MIPI only), YUV422, RGB565/444
- optical format:** 1/13"
- diagonal field of view (FOV):**
 - RYAA/RAAA: 64°
 - RYCA/RACA: 71.9°
- f no.:**
 - RYAA/RAAA: F/3.0
 - RYCA/RACA: F/2.8
- focal length:**
 - RYAA/RAAA: 1.15 mm
 - RYCA/RACA: 1.10 mm
- input clock frequency:** 6 - 27 MHz, 54 MHz
- max S/N ratio:** 38 dB
- dynamic range:** 66 dB
- maximum image transfer rate:**
 - VGA (640x480): 30 fps
 - CIF (352x288): 30 fps
 - QVGA (320x240): 60 fps
 - QCIF (176x144): 60 fps
- sensitivity:** 960 mV/lux-sec
- scan mode:** progressive
- maximum exposure interval:** 511 x t_{row}
- pixel size:** 1.75 μm x 1.75 μm
- dark current:** 10 mV/sec @ 60°C junction temperature
- image area:** 1148 μm x 861 μm
- package dimensions (including ball height):**
 - RYAA: 3470 x 2950 x 2760 μm
 - RAAA: 3179 x 2815 x 2600 μm
 - RYCA: 3450 x 2820 x 2350 μm
 - RACA: 3180 x 2820 x 2060 μm

Functional Block Diagram

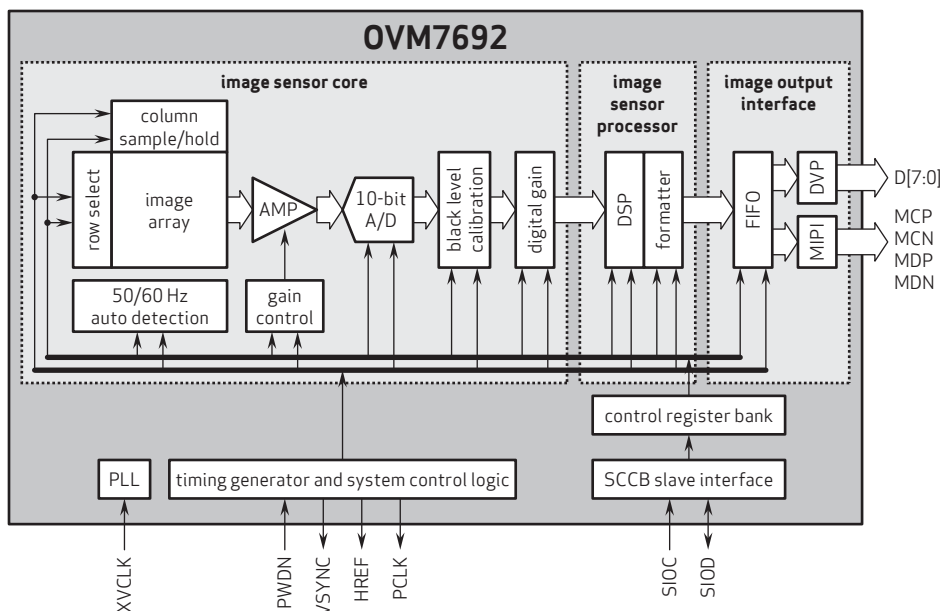

4275 Burton Drive
Santa Clara, CA 95054
USA

Tel: + 1 408 567 3000
Fax: + 1 408 567 3001
www.ovt.com

OmniVision reserves the right to make changes to their products or to discontinue any product or service without further notice. OmniVision, the OmniVision logo and OmniPixel are registered trademarks of OmniVision Technologies, Inc. CameraCubeChip and OmniPixel3-HS are trademarks of OmniVision Technologies, Inc. All other trademarks are the property of their respective owners.

Looking for pricing, stock, or lifecycle information?

Click below to explore more details on WIN SOURCE:

-  [View OVM7692-RAAA on WIN SOURCE](#)
-  [OmniVision Technologies Inc Information](#)

Optimize Your Supply Chain with WIN SOURCE Solutions

-  Global Sourcing Solution
-  Obsolete Management
-  Cost Control Management
-  Shortage Management
-  Alternative Solution
-  Excess Inventory Management