

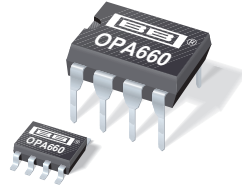

THE DATASHEET OF OPA660AP





OPA660

Wide Bandwidth OPERATIONAL TRANSCONDUCTANCE AMPLIFIER AND BUFFER

FEATURES

- WIDE BANDWIDTH: 850MHz
- HIGH SLEW RATE: 3000V/μs
- LOW DIFFERENTIAL GAIN/PHASE ERROR: 0.06%/0.02°
- VERSATILE CIRCUIT FUNCTION
- EXTERNAL I_Q-CONTROL

DESCRIPTION

The OPA660 is a versatile monolithic component designed for wide-bandwidth systems including high performance video, RF and IF circuitry. It includes a wideband, bipolar integrated voltage-controlled current source and voltage buffer amplifier.

The voltage-controlled current source or Operational Transconductance Amplifier (OTA) can be viewed as an "ideal transistor." Like a transistor, it has three terminals—a high-impedance input (base), a low-impedance input/output (emitter), and the current output (collector). The OTA, however, is self-biased and bipolar. The output current is zero-for-zero differential input voltage. AC inputs centered about zero produce an output current which is bipolar and centered about zero. The transconductance of the OTA can be adjusted with an external resistor, allowing bandwidth, quiescent current and gain trade-offs to be optimized.

The open-loop buffer amplifier provides 850MHz bandwidth and 3000V/μs slew rate. Used as a basic building block, the OPA660 simplifies the design of AGC amplifiers, LED driver circuits for Fiber Optic Transmission, integrators for fast pulses, fast control loop amplifiers, and control amplifiers for capacitive sensors and active filters.

The OPA660 is packaged in SO-8 surface-mount, and 8-pin plastic DIP, specified from -40°C to +85°C.

APPLICATIONS

- BASE LINE RESTORE CIRCUITS
- VIDEO/BROADCAST EQUIPMENT
- COMMUNICATIONS EQUIPMENT
- HIGH-SPEED DATA ACQUISITION
- WIDEBAND LED DRIVER
- AGC-MULTIPLIER
- NS-PULSE INTEGRATOR
- CONTROL LOOP AMPLIFIER
- 400MHz DIFFERENTIAL INPUT AMPLIFIER

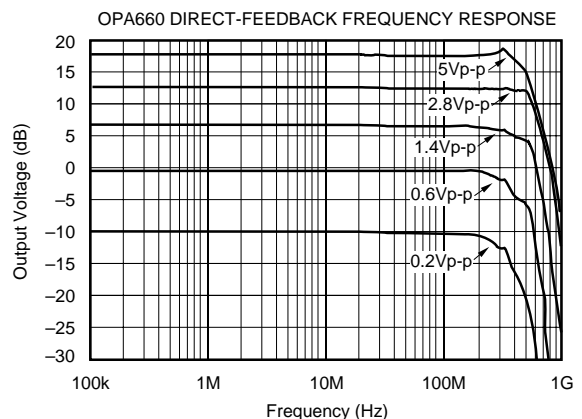
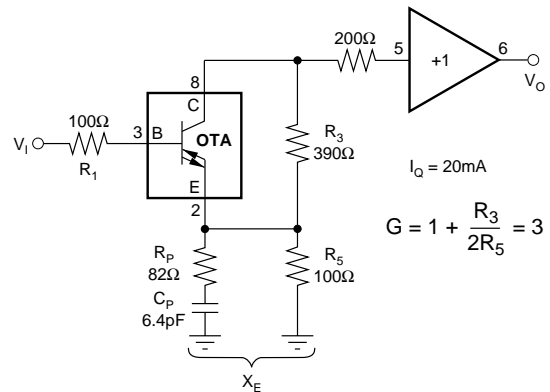

International Airport Industrial Park • Mailing Address: PO Box 11400, Tucson, AZ 85734 • Street Address: 6730 S. Tucson Blvd., Tucson, AZ 85706 • Tel: (520) 746-1111 • Twx: 910-952-1111
Internet: <http://www.burr-brown.com/> • FAXLine: (800) 548-6133 (US/Canada Only) • Cable: BBRCORP • Telex: 066-6491 • FAX: (520) 889-1510 • Immediate Product Info: (800) 548-6132

PIN CONFIGURATION

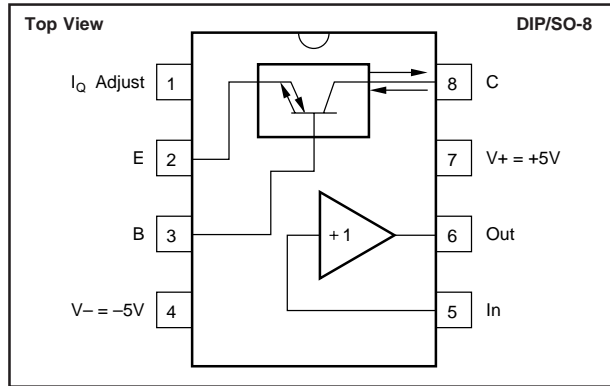

ELECTROSTATIC DISCHARGE SENSITIVITY

This integrated circuit can be damaged by ESD. Burr-Brown recommends that all integrated circuits be handled with appropriate precautions. Failure to observe proper handling and installation procedures can cause damage.

ESD damage can range from subtle performance degradation to complete device failure. Precision integrated circuits may be more susceptible to damage because very small parametric changes could cause the device not to meet its published specifications.

ABSOLUTE MAXIMUM RATINGS

Power Supply Voltage	$\pm 6V$
Input Voltage ⁽¹⁾	$\pm V_S \pm 0.7V$
Operating Temperature	$-40^\circ C$ to $+85^\circ C$
Storage Temperature	$-40^\circ C$ to $+125^\circ C$
Junction Temperature	$+175^\circ C$
Lead Temperature (soldering, 10s)	$+300^\circ C$

NOTE: (1) Inputs are internally diode-clamped to $\pm V_S$.

PACKAGE/ORDERING INFORMATION

PRODUCT	PACKAGE	PACKAGE DRAWING NUMBER ⁽¹⁾	TEMPERATURE RANGE
OPA660AP	8-Pin Plastic DIP	006	$-25^\circ C$ to $+85^\circ C$
OPA660AU	SO-8 Surface-Mount	182	$-25^\circ C$ to $+85^\circ C$

NOTE: (1) For detailed drawing and dimension table, please see end of data sheet, or Appendix C of Burr-Brown IC Data Book.

The information provided herein is believed to be reliable; however, BURR-BROWN assumes no responsibility for inaccuracies or omissions. BURR-BROWN assumes no responsibility for the use of this information, and all use of such information shall be entirely at the user's own risk. Prices and specifications are subject to change without notice. No patent rights or licenses to any of the circuits described herein are implied or granted to any third party. BURR-BROWN does not authorize or warrant any BURR-BROWN product for use in life support devices and/or systems.

TYPICAL PERFORMANCE CURVES

$I_Q = 20\text{mA}$, $T_A = +25^\circ\text{C}$, and $V_S = \pm 5\text{V}$ unless otherwise noted.

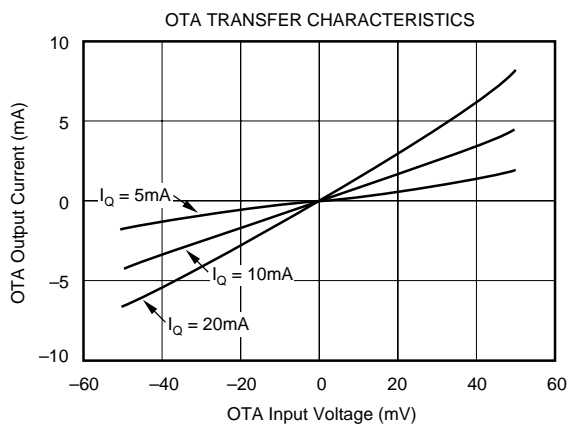
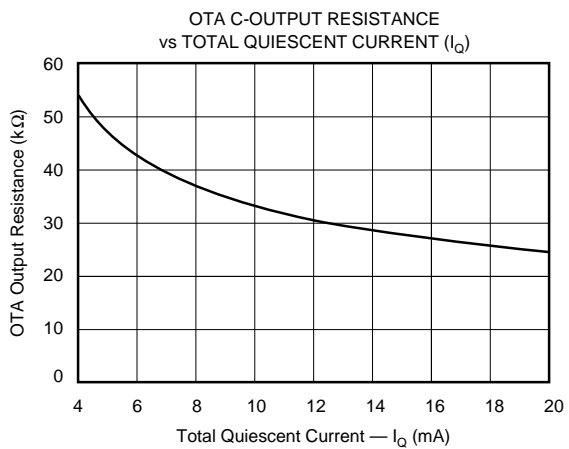
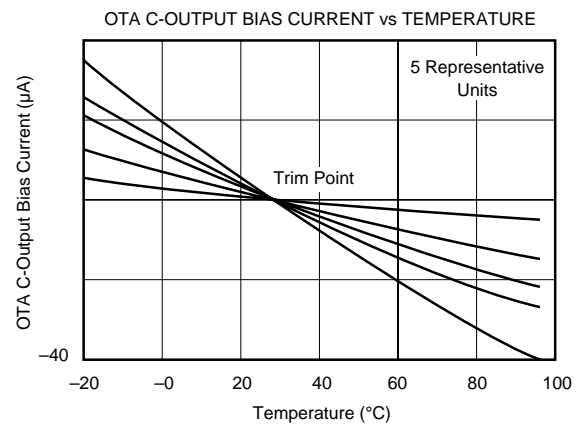
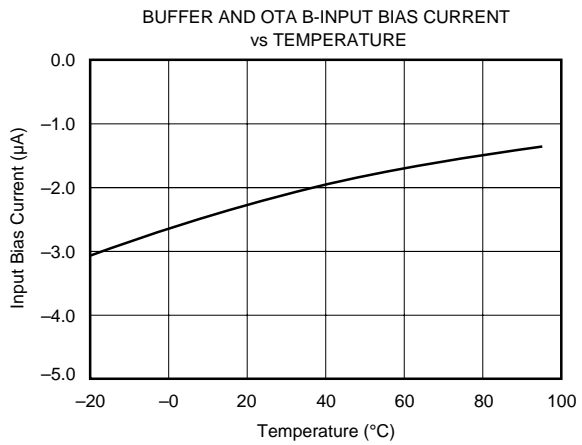
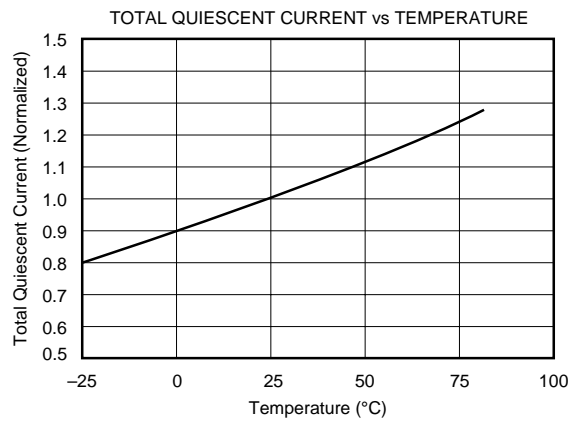
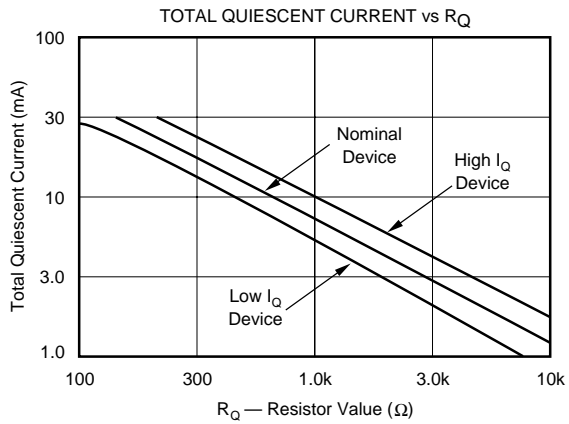

TYPICAL PERFORMANCE CURVES (CONT)

$I_Q = 20\text{mA}$, $T_A = +25^\circ\text{C}$, and $V_S = \pm 5\text{V}$ unless otherwise noted.

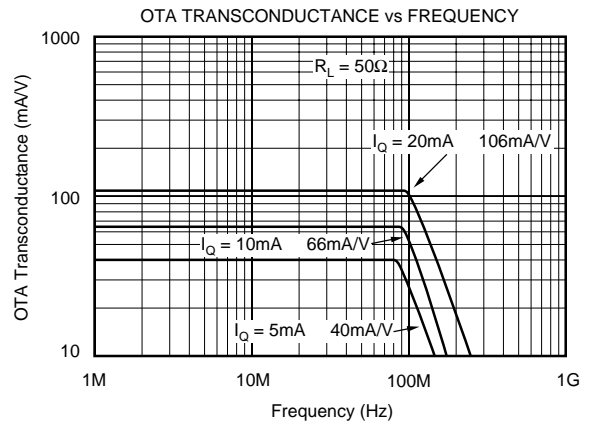
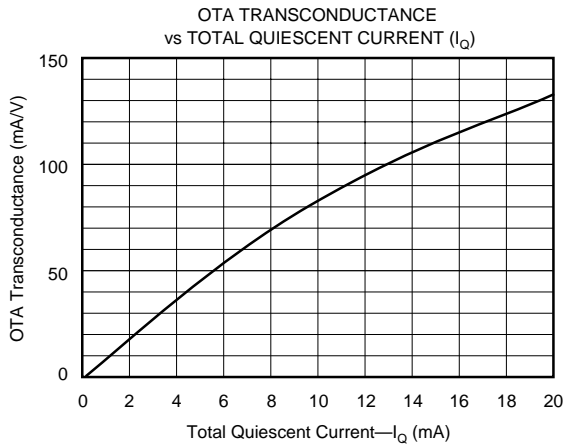
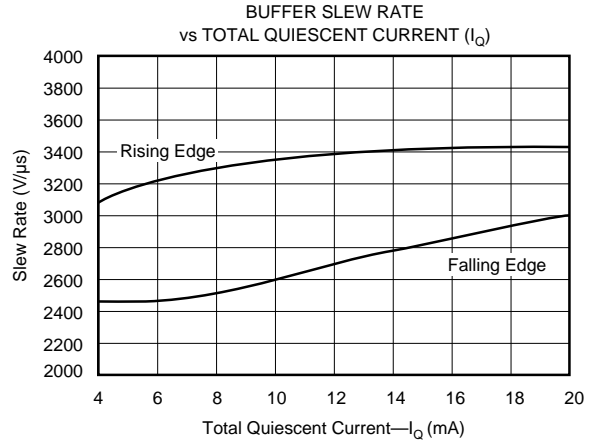
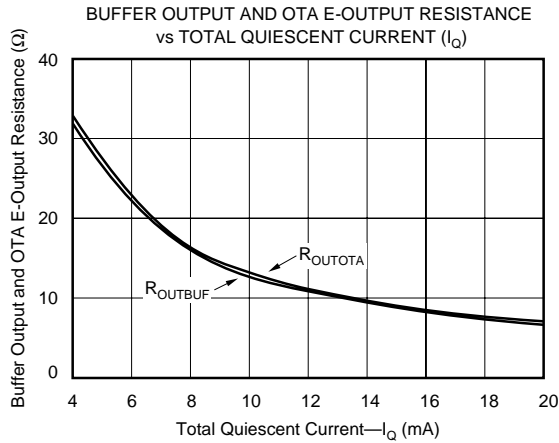
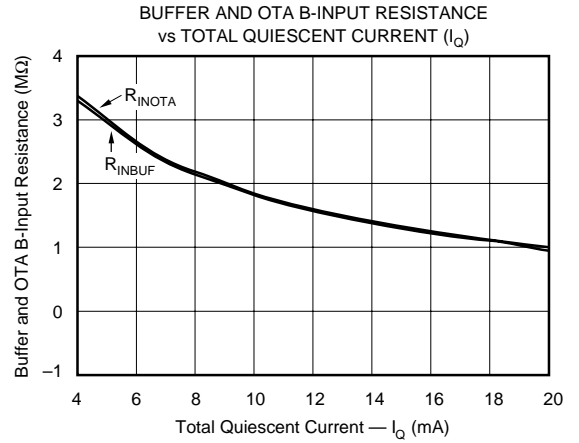
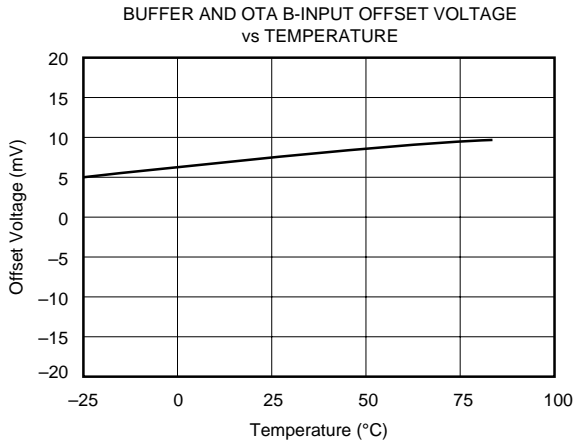

TYPICAL PERFORMANCE CURVES (CONT)

$I_Q = 20\text{mA}$, $T_A = +25^\circ\text{C}$, and $V_S = \pm 5\text{V}$ unless otherwise noted.

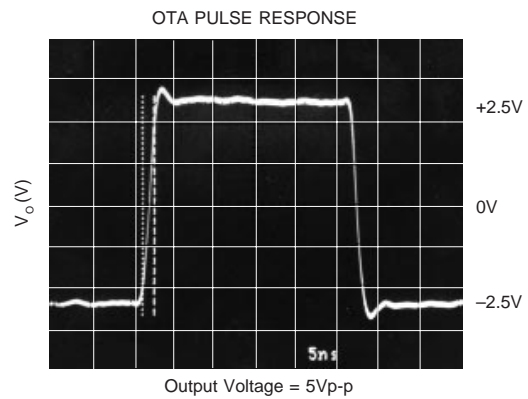
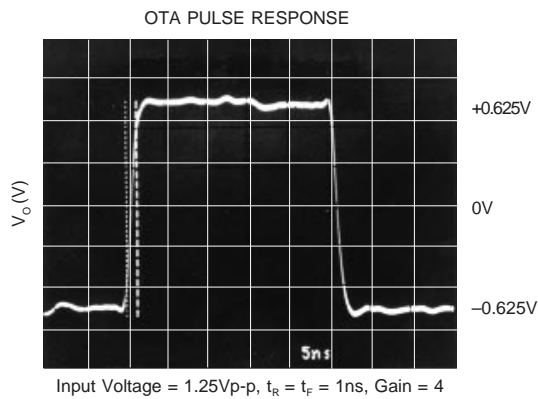
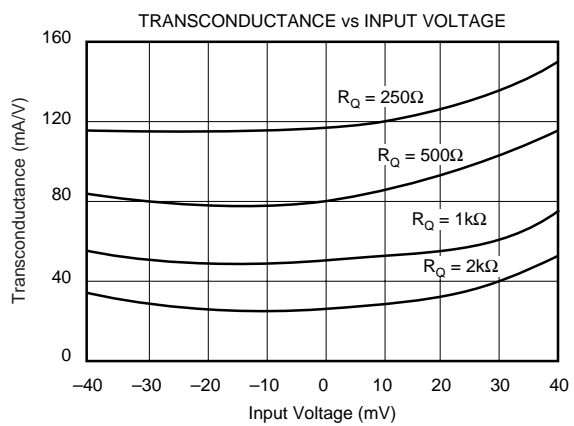
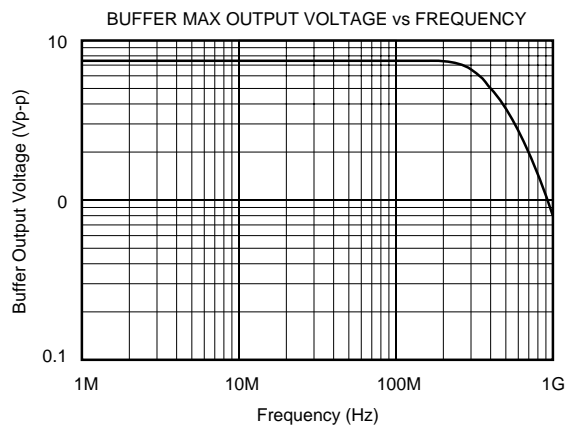
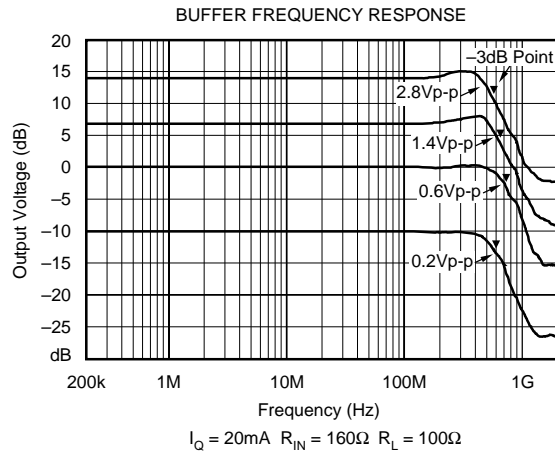
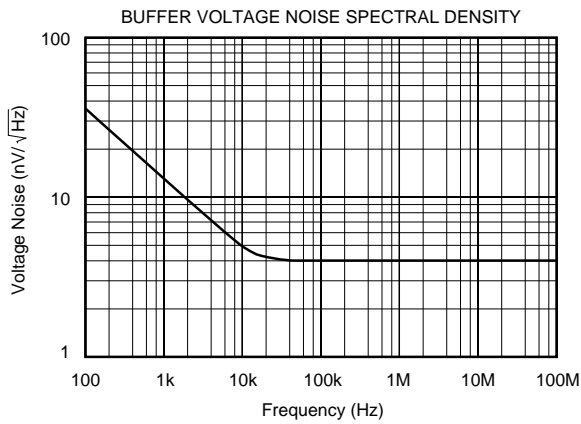

TYPICAL PERFORMANCE CURVES (CONT)

$I_Q = 20\text{mA}$, $T_A = +25^\circ\text{C}$, and $V_S = \pm 5\text{V}$ unless otherwise noted.

BUFFER LARGE SIGNAL PULSE RESPONSE

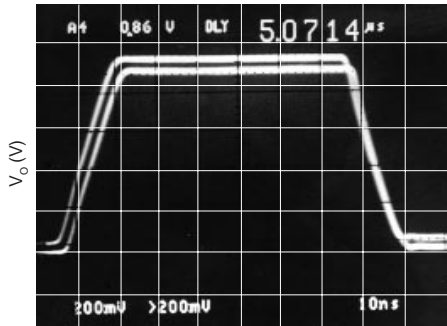

(HDTV Signal Pulse) $t_R = t_F = 10\text{ns}$, $V_O = 5\text{Vp-p}$

BUFFER LARGE SIGNAL PULSE RESPONSE

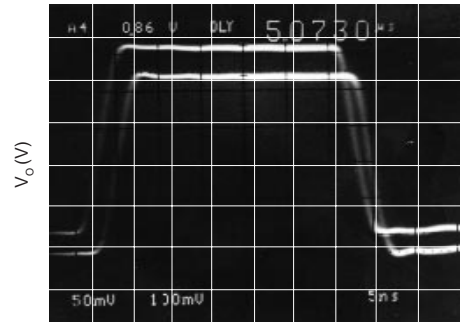

$t_R = t_F = 3\text{ns}$, $V_O = 5\text{Vp-p}$

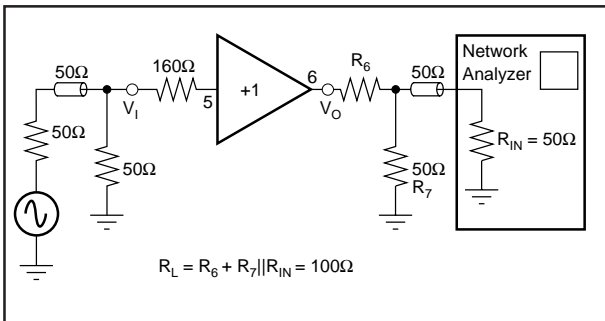

Test Circuit Buffer Pulse and Frequency Response

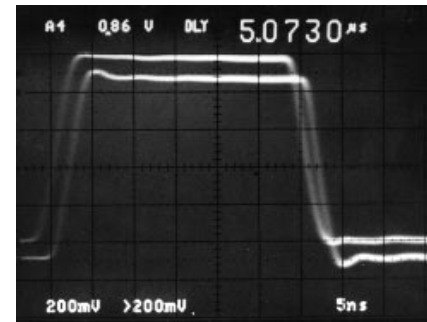

$t_R = t_F = 3\text{ns}$, $V_O = 0.2\text{Vp-p}$

BUFFER DIFFERENTIAL GAIN ERROR vs TOTAL QUIESCENT CURRENT (I_Q)

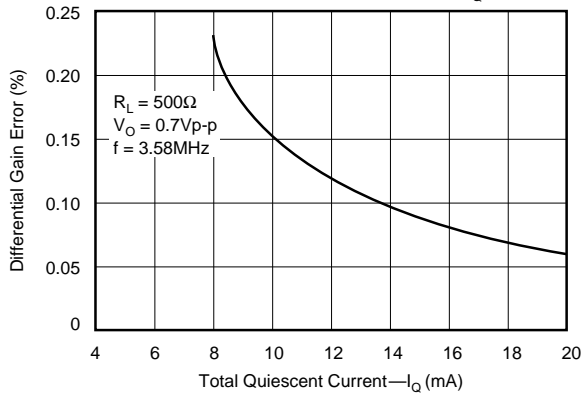

BUFFER DIFFERENTIAL PHASE ERROR vs TOTAL QUIESCIENT CURRENT (I_Q)

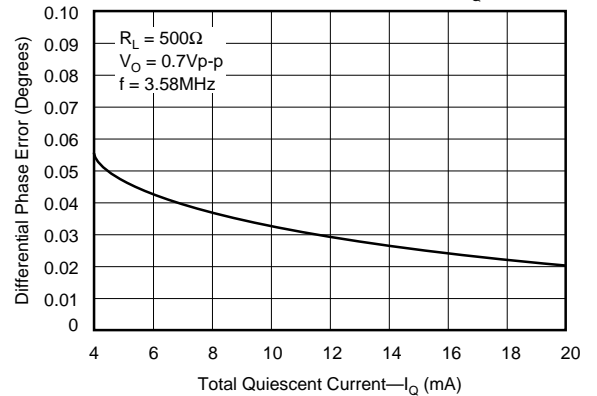

TYPICAL PERFORMANCE CURVES (CONT)

$I_Q = 20\text{mA}$, $T_A = +25^\circ\text{C}$, and $V_S = \pm 5\text{V}$ unless otherwise noted.

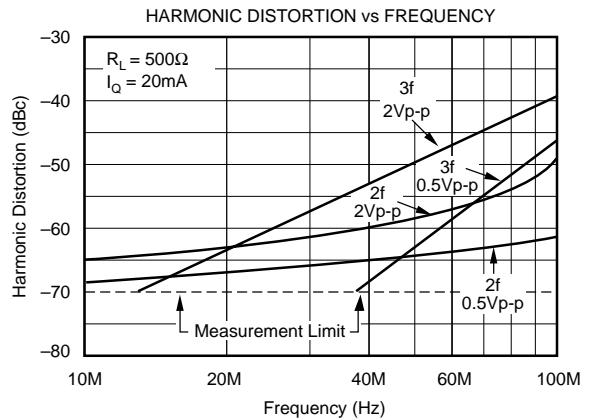
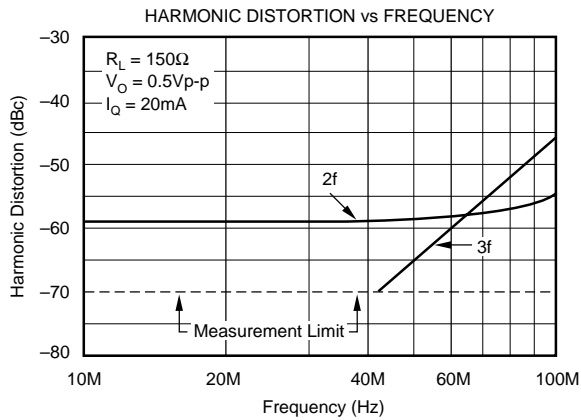

APPLICATIONS INFORMATION

The OPA660 operates from $\pm 5\text{V}$ power supplies ($\pm 6\text{V}$ maximum). Do not attempt to operate with larger power supply voltages or permanent damage may occur.

Inputs of the OPA660 are protected with internal diode clamps as shown in the simplified schematic, Figure 1. These protection diodes can safely conduct 10mA , continuously (30mA peak). If input voltages can exceed the power supply voltages by 0.7V , the input signal current must be limited.

The buffer output is not current-limited or protected. If the output is shorted to ground, currents up to 60mA could flow. Momentary shorts to ground (a few seconds) should be avoided, but are unlikely to cause permanent damage. The same cautions apply to the OTA section when connected as a buffer (see Basic Applications Circuits, Figure 6b).

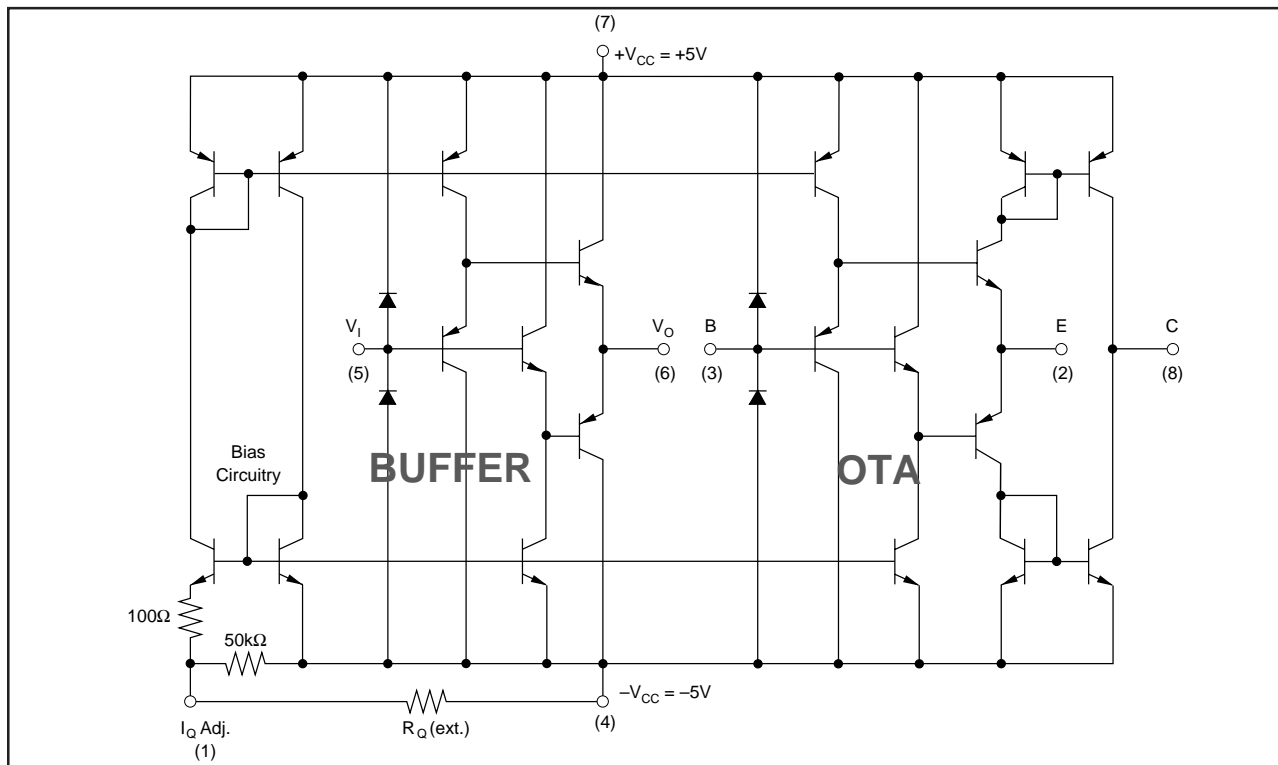

FIGURE 1. Simplified Circuit Diagram.

BUFFER SECTION—AN OVERVIEW

The buffer section of the OPA660 is an open-loop buffer consisting of complementary emitter-followers. It uses no feedback, so its low frequency gain is slightly less than unity and somewhat dependent on loading. It is designed primarily for interstage buffering. It is not designed for driving long cables or low impedance loads (although with small signals, it may be satisfactory for these applications).

TRANSCONDUCTANCE (OTA) SECTION—AN OVERVIEW

The symbol for the OTA section is similar to a transistor. Applications circuits for the OTA look and operate much like transistor circuits—the transistor, too, is a voltage-controlled current source. Not only does this simplify the understanding of applications circuits, but it aids the circuit optimization process. Many of the same intuitive techniques used with transistor designs apply to OTA circuits as well.

The three terminals of the OTA are labeled B, E, and C. This calls attention to its similarity to a transistor, yet draws distinction for clarity.

While it is similar to a transistor, one essential difference is the sense of the C output current. It flows out the C terminal for positive B-to-E input voltage and in the C terminal for negative B-to-E input voltage. The OTA offers many advantages over a discrete transistor. The OTA is self-biased, simplifying the design process and reducing component count. The OTA is far more linear than a transistor. Transconductance of the OTA is constant over a wide range of collector currents—this implies a fundamental improvement of linearity.

BASIC CONNECTIONS

Figure 2 shows basic connections required for operation. These connections are not shown in subsequent circuit diagrams. Power supply bypass capacitors should be located as close as possible to the device pins. Solid tantalum capacitors are generally best. See “Circuit Layout” at the end of the applications discussion and Figure 26 for further suggestions on layout.

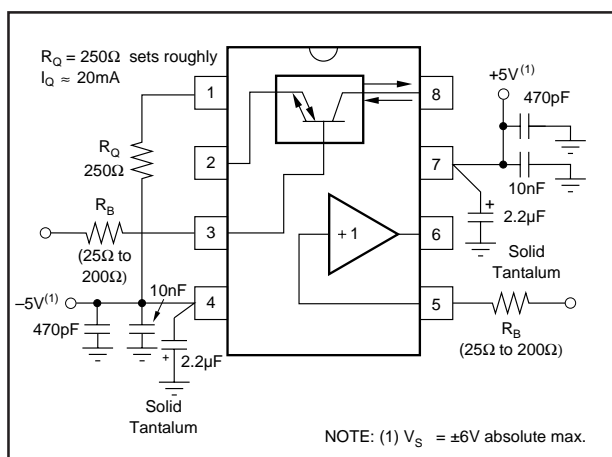

FIGURE 2. Basic Connections.

QUIESCENT CURRENT CONTROL PIN

The quiescent current of the OPA660 is set with a resistor, R_Q , connected from pin 1 to V_- . It affects the operating currents of both the buffer and OTA sections. This controls the bandwidth and AC behavior as well as the transconductance of the OTA section.

$R_Q = 250\Omega$ sets approximately 20mA total quiescent current at 25°C. With a fixed 250Ω resistor, process variations could cause this current to vary from approximately 16mA to 26mA. It may be appropriate in some applications to trim this resistor to achieve the desired quiescent current or AC performance.

Applications circuits generally do not show resistor, R_Q , but it is required for proper operation.

With a fixed R_Q resistor, quiescent current increases with temperature (see typical performance curve, Quiescent Current vs Temperature). This variation of current with temperature holds the transconductance, g_m , of the OTA relatively constant with temperature (another advantage over a transistor).

It is also possible to vary the quiescent current with a control signal. The control loop in Figure 3 shows a 1/2 of a REF200 current source used to develop 100mV on R_1 . The loop forces 100mV to appear on R_2 . Total quiescent current of the OPA660 is approximately $85 \cdot I_1$, where I_1 is the current made to flow out of pin 1.

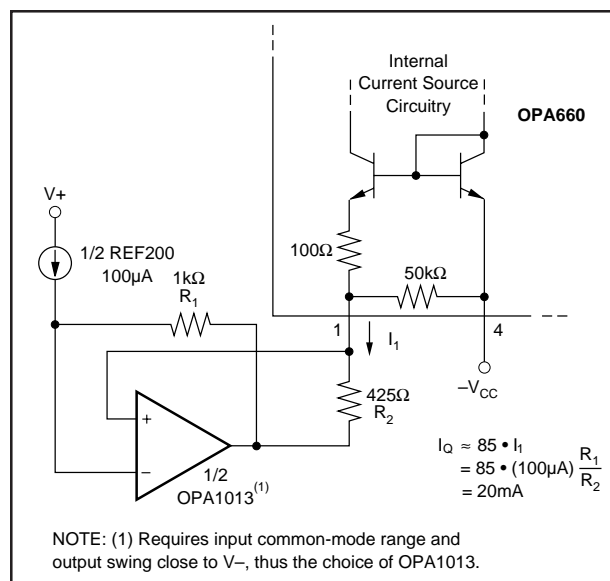

FIGURE 3. Optional Control Loop for Setting Quiescent Current.

With this control loop, quiescent current will be nearly constant with temperature. Since this differs from the temperature-dependent behavior of the internal current source, other temperature-dependent behavior may differ from that shown in typical performance curves.

The circuit of Figure 3 will control the I_Q of the OPA660 somewhat more accurately than with a fixed external resistor, R_Q . Otherwise, there is no fundamental advantage to

using this more complex biasing circuitry. It does, however, demonstrate the possibility of signal-controlled quiescent current. This may suggest other possibilities such as AGC, dynamic control of AC behavior, or VCO.

Figure 4 shows logic control of pin 1 used to disable the OPA660. Zero/5V logic levels are converted to a 1mA/0mA current connected to pin 1. The 1mA current flowing in R_Q increases the voltage at pin 1 to approximately 1V above the -5V rail. This will reduce I_Q to near zero, disabling the OPA660.

BASIC APPLICATIONS CIRCUITS

Most applications circuits for the OTA section consist of a few basic types which are best understood by analogy to a transistor. Just as the transistor has three basic operating modes—common emitter, common base, and common collector—the OTA has three equivalent operating modes common-E, common-B, and common-C. See Figures 5, 6, and 7.

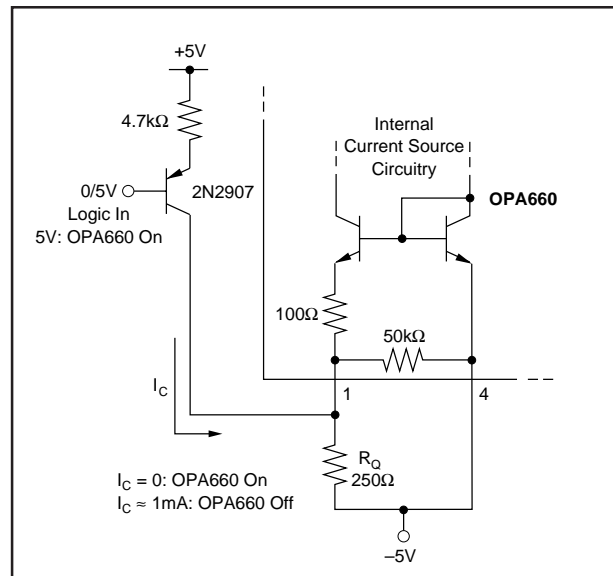

FIGURE 4. Logic-Controlled Disable Circuit.

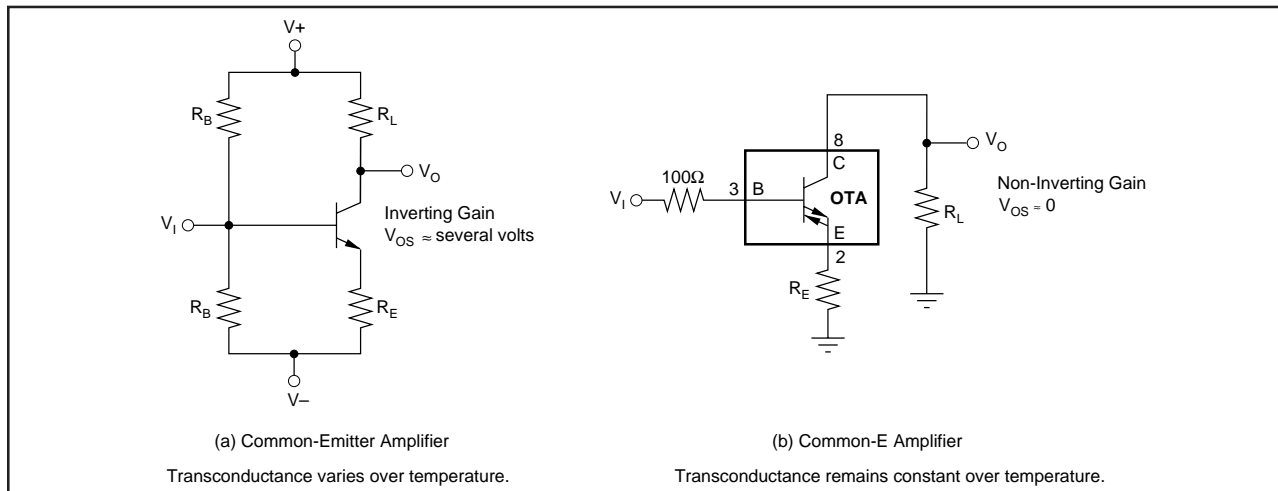

FIGURE 5. Common-Emitter vs Common-E Amplifier.

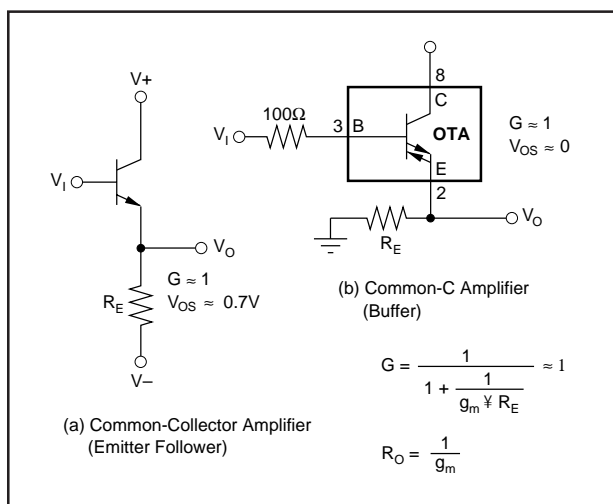

FIGURE 6. Common-Collector vs Common-C Amplifier.

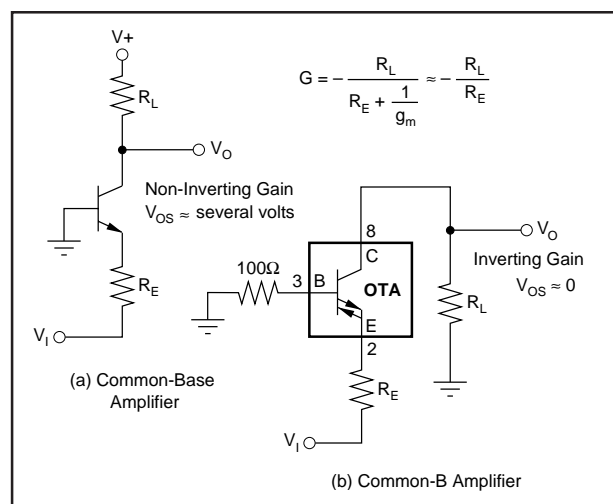

FIGURE 7. Common-Base vs Common-B Amplifier.

A positive voltage at the B, pin 3, causes a positive current to flow out of the C, pin 8. Figure 5b shows an amplifier connection of the OTA, the equivalent of a common-emitter transistor amplifier. Input and output can be ground-referenced without any biasing. Due to the sense of the output current, the amplifier is non-inverting. Figure 8 shows the amplifier with various gains and output voltages using this configuration.

Just as transistor circuits often use emitter degeneration, OTA circuits may also use degeneration. This can be used to reduce the effect that offset voltage and offset current might otherwise have on the DC operating point of the OTA. The E-degeneration resistor may be bypassed with a large capacitor to maintain high AC gain. Other circumstances may suggest a smaller value capacitor used to extend or optimize high-frequency performance.

The transconductance of the OTA with degeneration can be calculated by—

$$g_m' = \frac{1}{\frac{1}{g_m} + R_E}$$

Figure 6b shows the OTA connected as an E-follower—a voltage buffer. The buffer formed by this connection performs virtually the same as the buffer section of the OPA660 (the actual signal path is identical).

It is recommended to use a low value resistor in series with the B OTA and buffer inputs. This reduces any tendency to oscillate and controls frequency response peaking. Values from 25Ω to 200Ω are typical.

Figure 7 shows the Common-B amplifier. This configuration produces an inverting gain, and a low impedance input. This low impedance can be converted to a high impedance by inserting the buffer amplifier in series.

CIRCUIT LAYOUT

The high frequency performance of the OPA660 can be greatly affected by the physical layout of the circuit. The following tips are offered as suggestions, not dogma.

- Bypass power supplies very close to the device pins. Use a combination between tantalum capacitors (approximately 2.2μF) and polyester capacitors. Surface-mount types are best because they provide lowest inductance.
- Make short, wide interconnection traces to minimize series inductance.
- Use a large ground plane to assure that a low impedance ground is available throughout the layout.
- Do not extend the ground plane under high impedance nodes sensitive to stray capacitance.
- Sockets are not recommended because they add significant inductance.

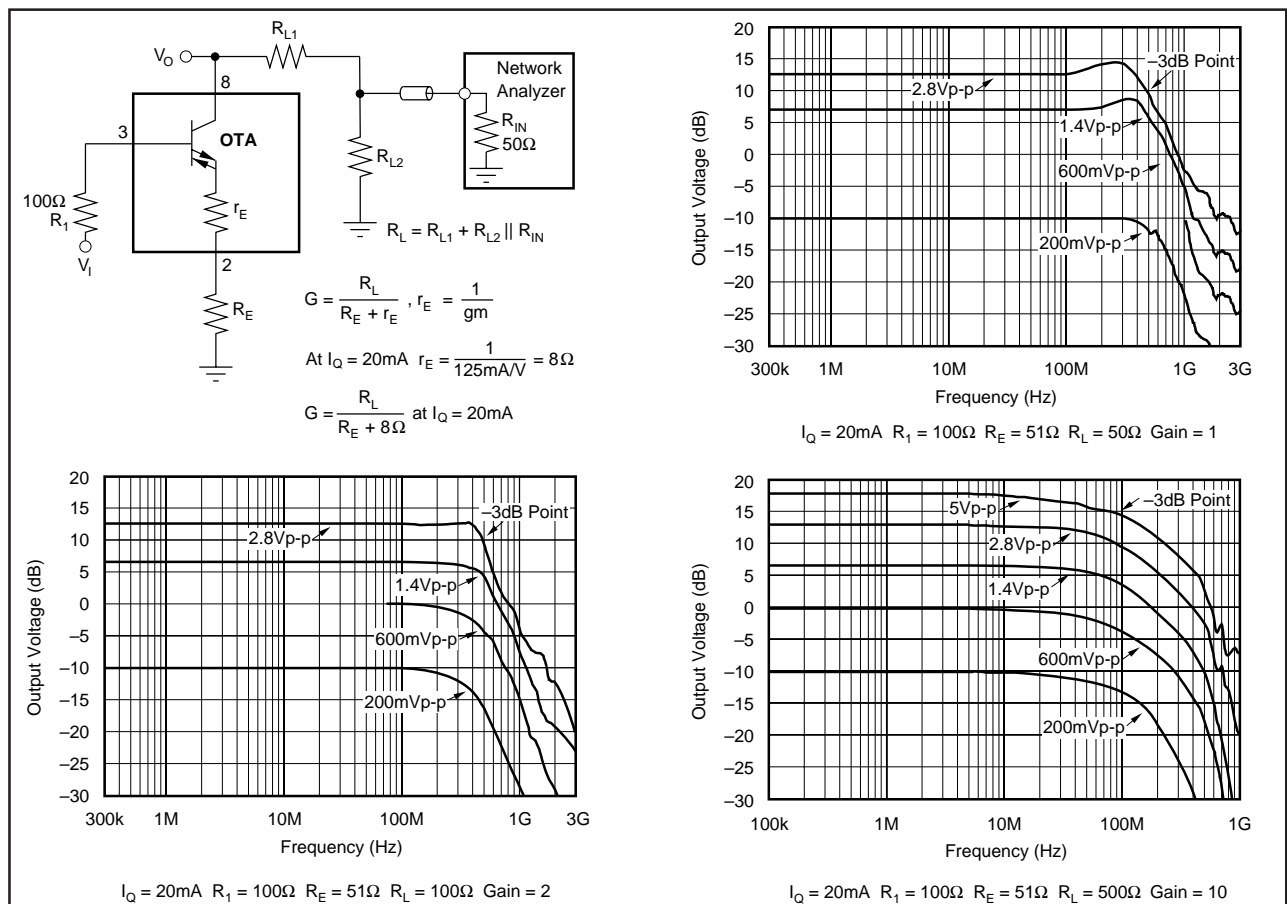

FIGURE 8. Common-E Amplifier Performance.

- Use low-inductance components. Some film resistors are trimmed with spiral cuts which increase inductance.
- Use surface-mount components—they generally provide the lowest inductance.

- A resistor (25Ω to 200Ω) in series with the buffer and/or B input may help reduce oscillations and peaking.
- Use series resistors in the supply lines to decouple multiple devices.

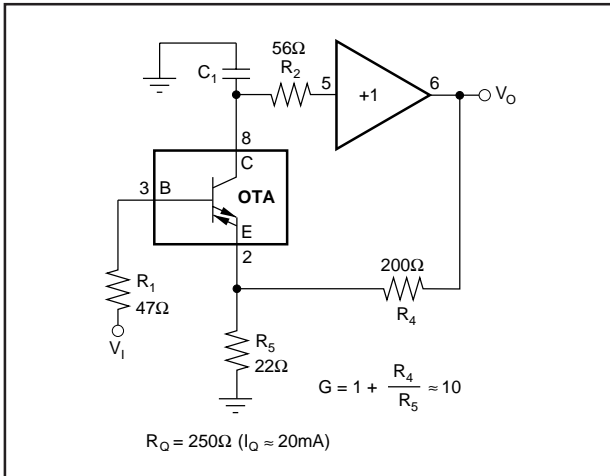

FIGURE 9. Current-Feedback Amplifier.

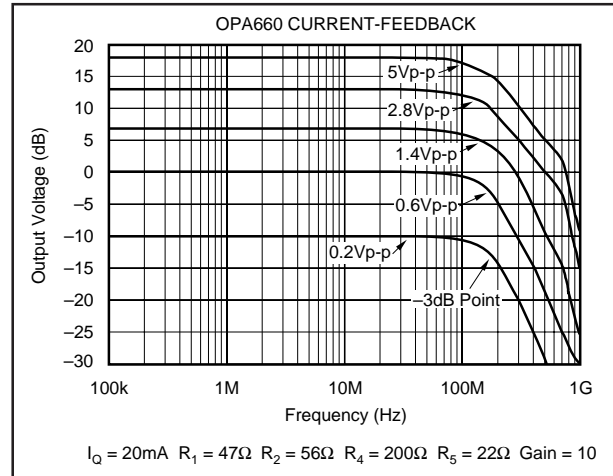

FIGURE 10. Current-Feedback Amplifier Frequency Response, $G = 10$.

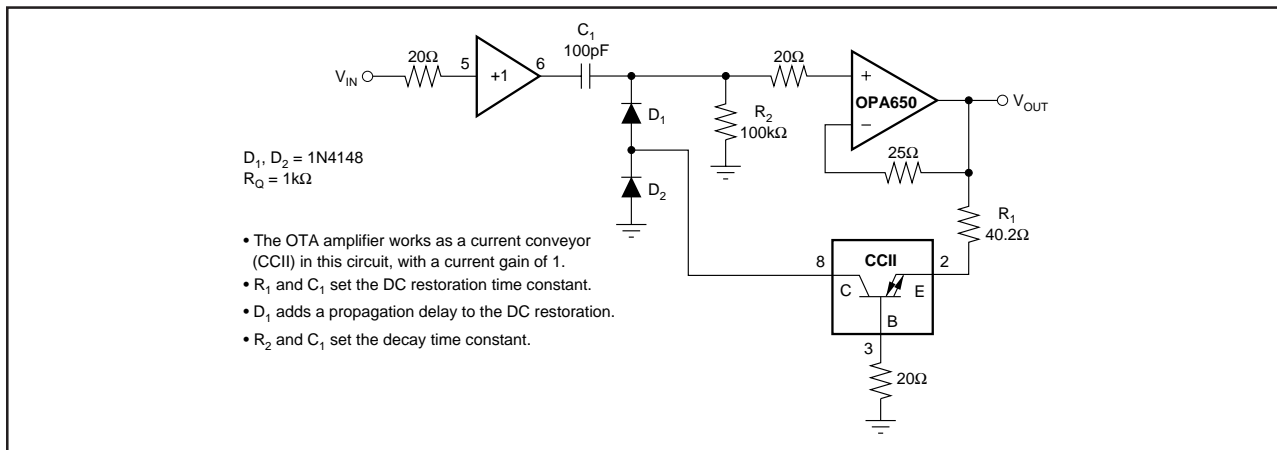

FIGURE 11. DC Restorer Circuit.

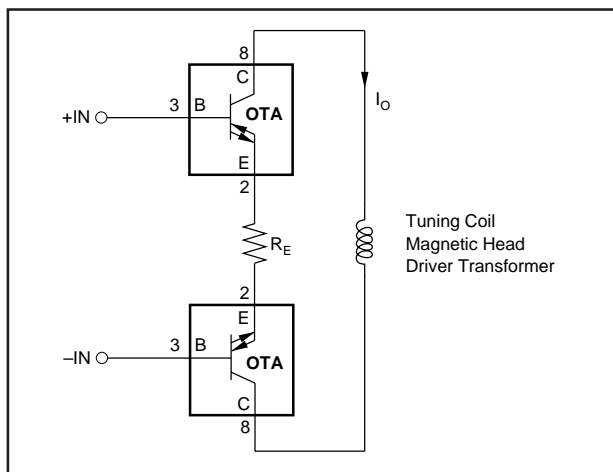

FIGURE 12. High Speed Current Driver (bridge combination for increased output voltage capability).

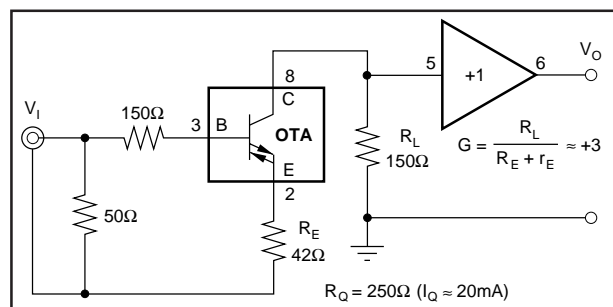

FIGURE 13. Cable Amplifier.

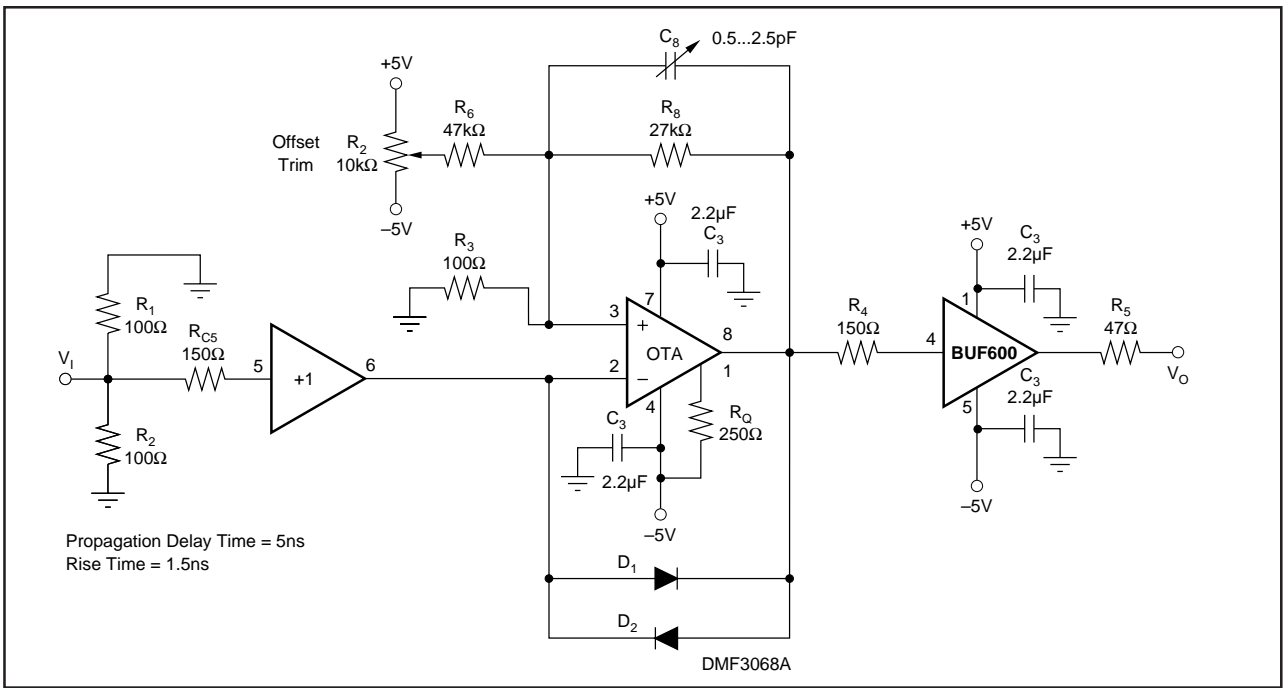

FIGURE 14. Comparator (Low Jitter).

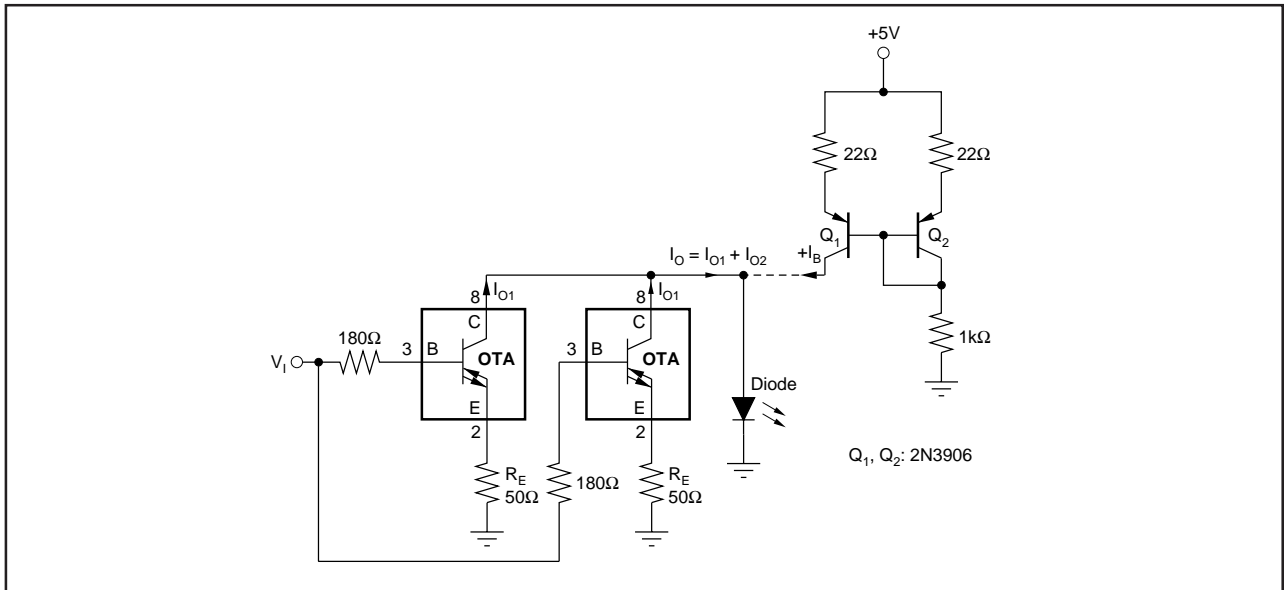

FIGURE 15. High Speed Current Driver.

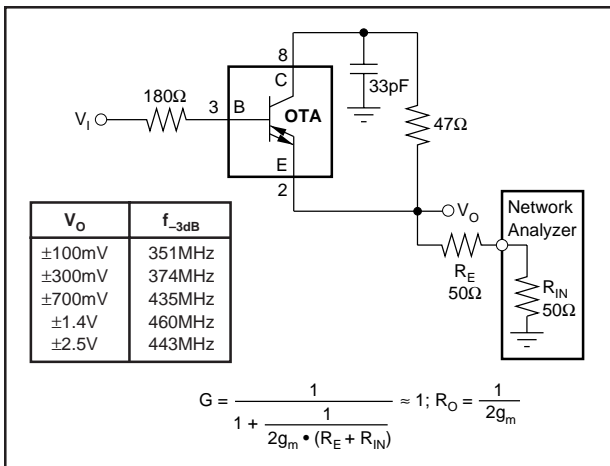

FIGURE 16. Voltage Buffer with Doubled-Output Current.

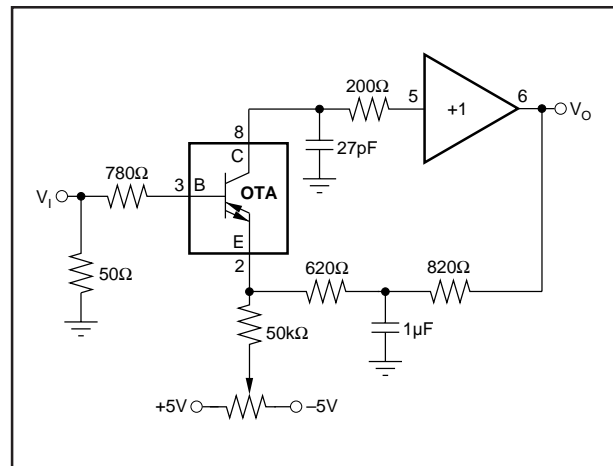

FIGURE 17. Integrator for ns-pulses.

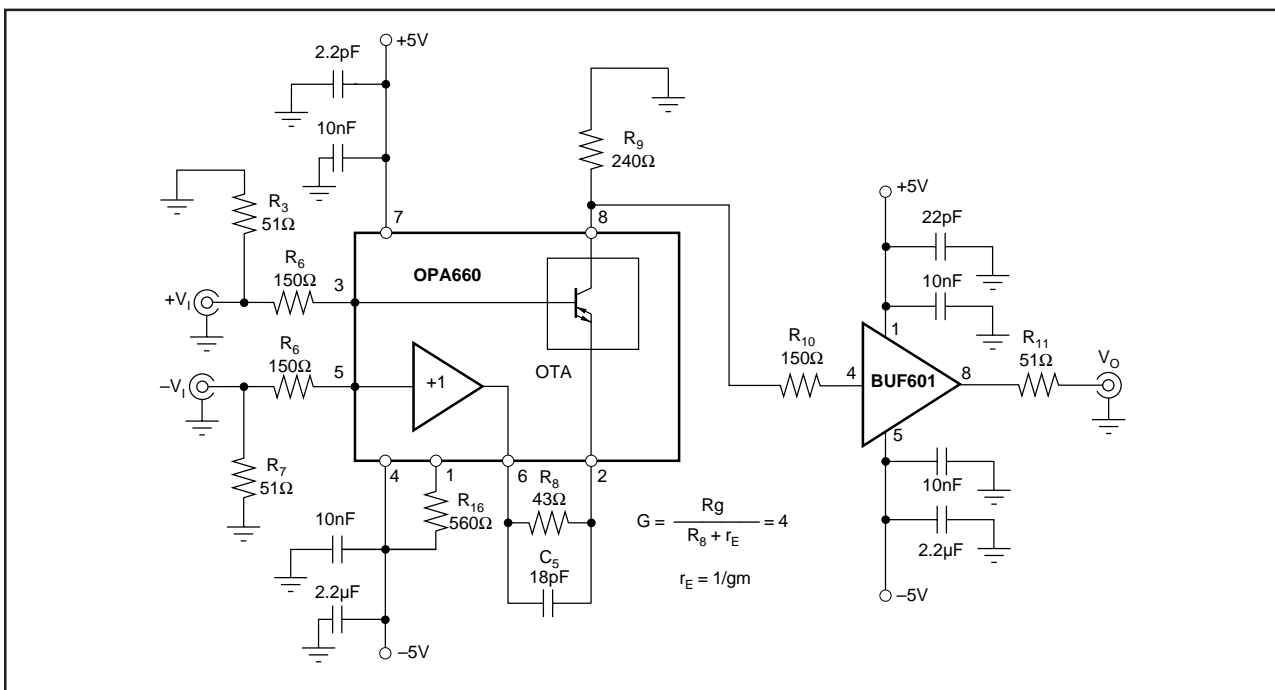

FIGURE 18. 400MHz Differential Amplifier

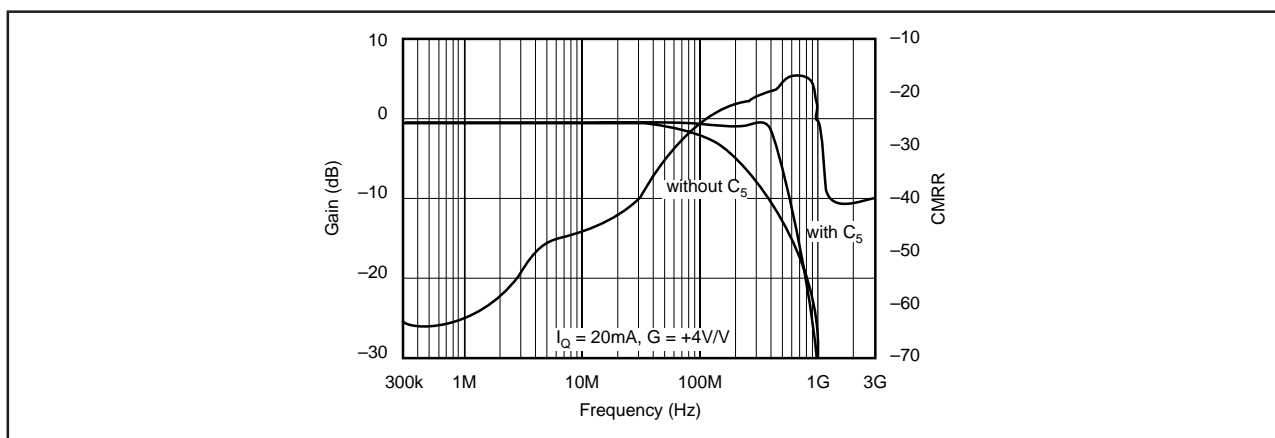

FIGURE 19. CMRR and Bandwidth of the Differential Amplifier

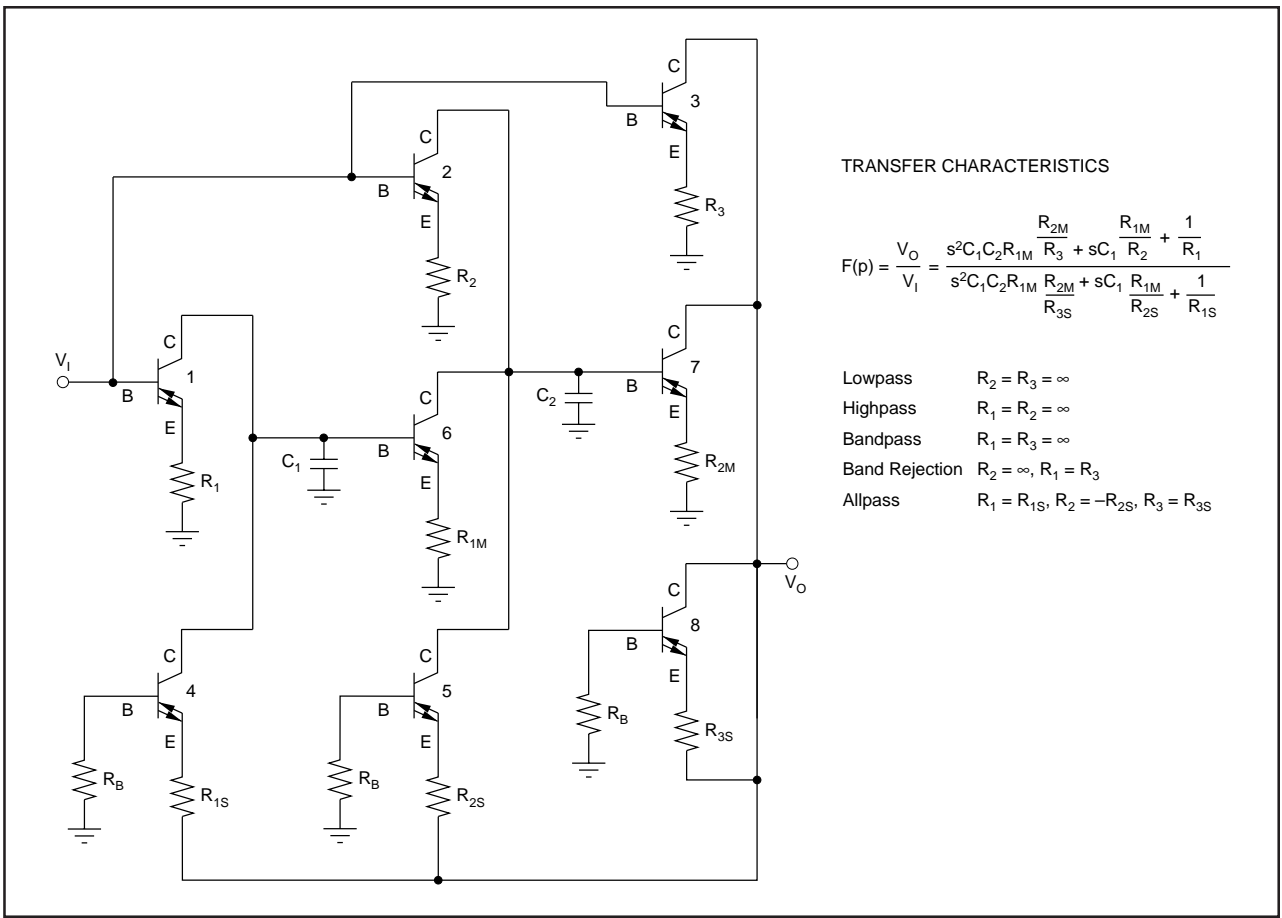

FIGURE 20. High Frequency Universal Active Filter.

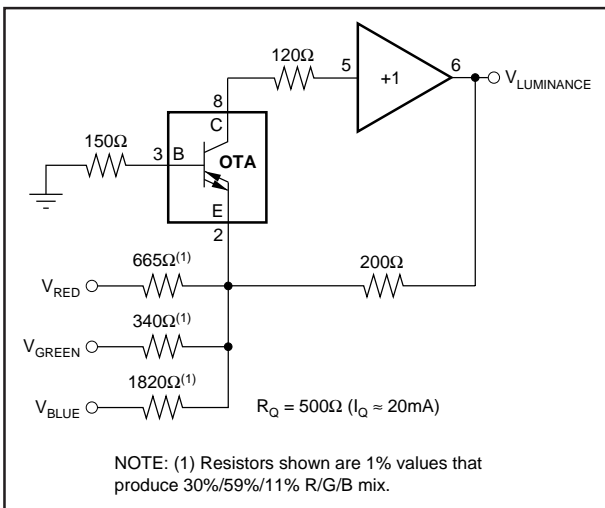

FIGURE 21. Video Luminance Matrix.

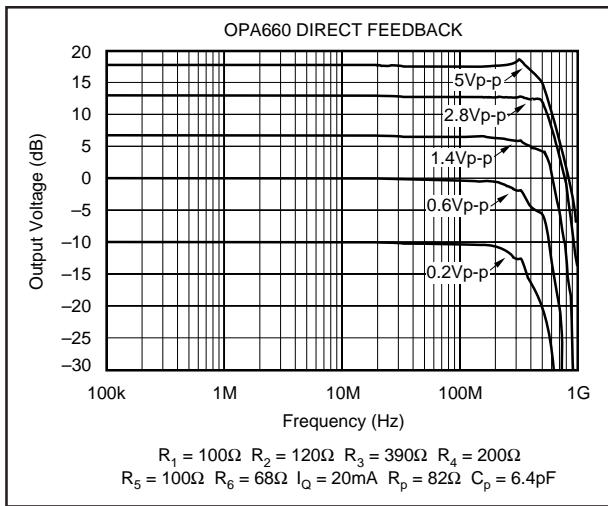

FIGURE 24. Frequency Response Direct-Feedback Amplifier.

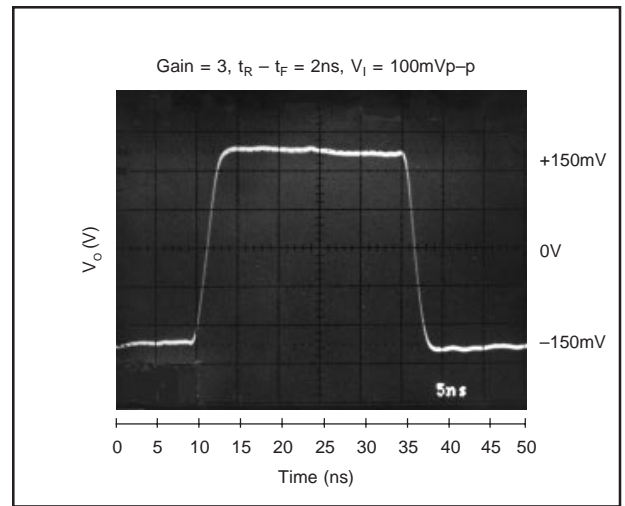

FIGURE 25. Direct-Feedback Amplifier Small-Signal Pulse Response.

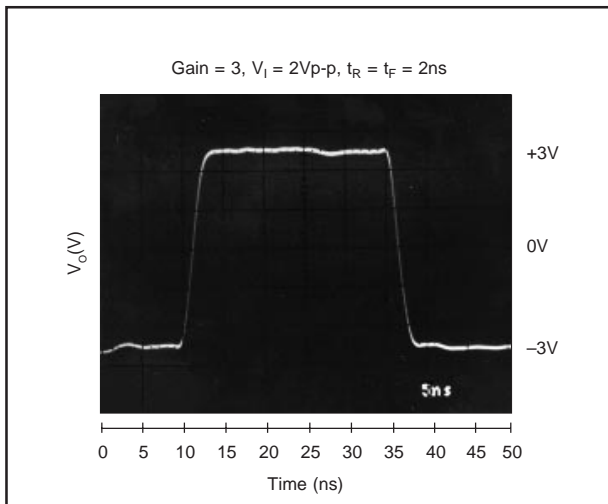

FIGURE 26. Direct-Feedback Amplifier Large-Signal Pulse Response.

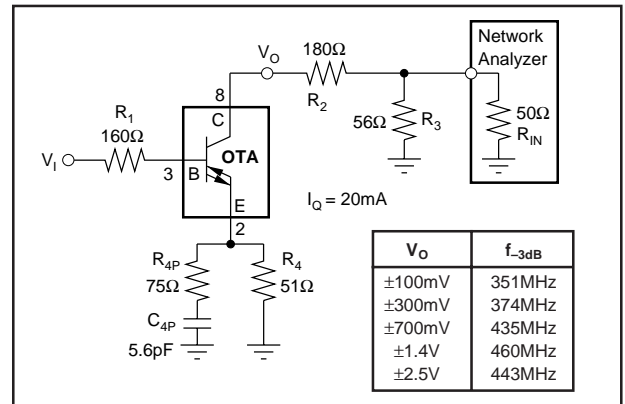

FIGURE 27. Forward Amplifier.

SPICE MODELS

Computer simulation using SPICE models is often useful when analyzing the performance of analog circuits and systems. This is particularly true for video and RF amplifier circuits, where parasitic capacitance and inductance can have a major effect on circuit performance. SPICE models are available from Burr-Brown.

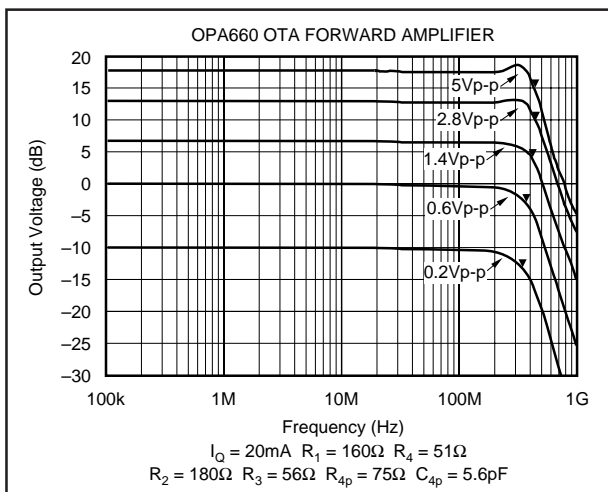

FIGURE 28. Frequency Response Forward Amplifier.

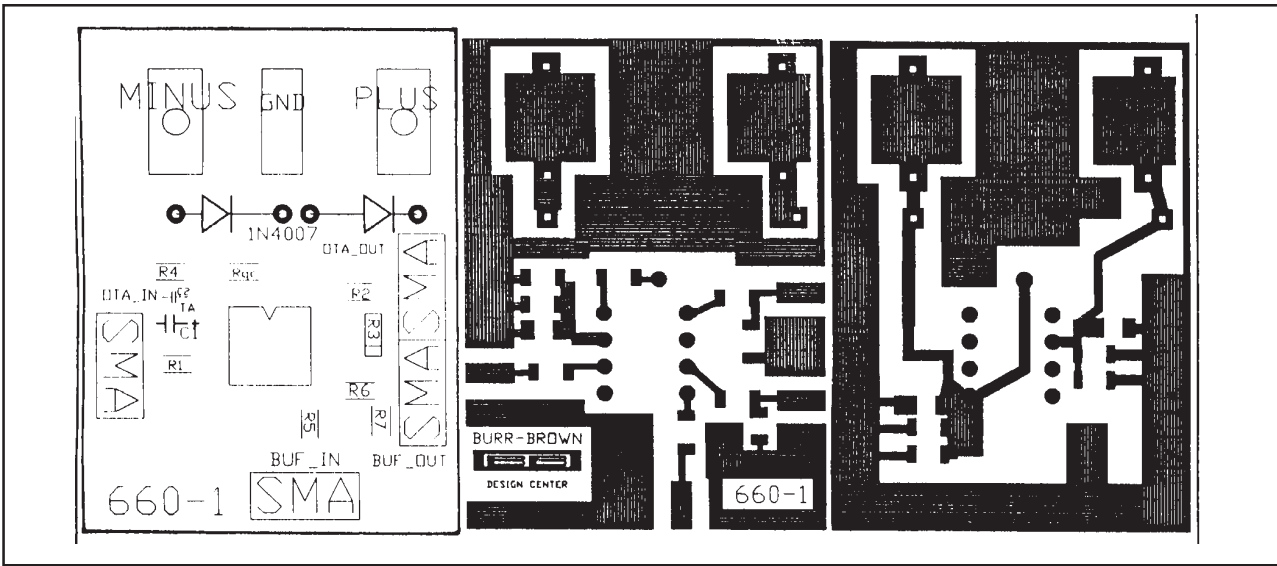

FIGURE 29. Evaluation Circuit Silk Screen and Board Layouts.

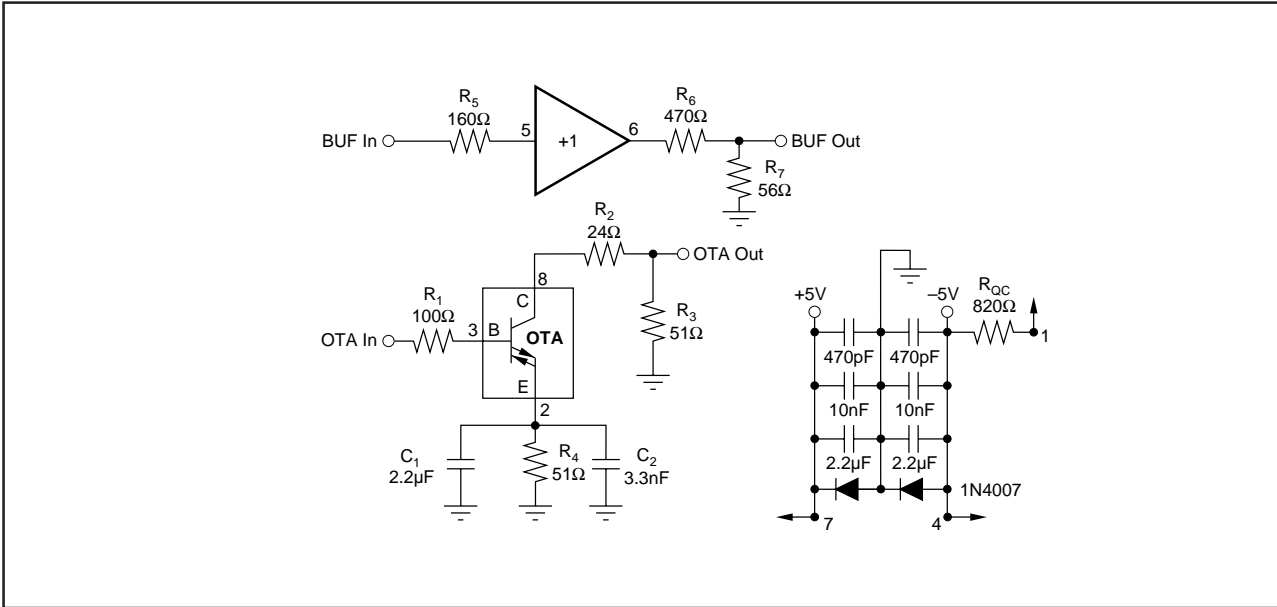

FIGURE 30. Evaluation Circuit Diagram.

PACKAGING INFORMATION

ORDERABLE DEVICE	STATUS(1)	PACKAGE TYPE	PACKAGE DRAWING	PINS	PACKAGE QTY
OPA660AP	LIFEBUY	PDIP	P	8	50
OPA660AU	LIFEBUY	SOIC	D	8	100
OPA660AU/2K5	LIFEBUY	SOIC	D	8	2500

(1) The marketing status values are defined as follows:

ACTIVE: Product device recommended for new designs.

LIFEBUY: TI has announced that the device will be discontinued, and a lifetime-buy period is in effect.

NRND: Not recommended for new designs. Device is in production to support existing customers, but TI does not recommend using this part in a new design.

PREVIEW: Device has been announced but is not in production. Samples may or may not be available.

OBSOLETE: TI has discontinued the production of the device.

IMPORTANT NOTICE

Texas Instruments Incorporated and its subsidiaries (TI) reserve the right to make corrections, modifications, enhancements, improvements, and other changes to its products and services at any time and to discontinue any product or service without notice. Customers should obtain the latest relevant information before placing orders and should verify that such information is current and complete. All products are sold subject to TI's terms and conditions of sale supplied at the time of order acknowledgment.

TI warrants performance of its hardware products to the specifications applicable at the time of sale in accordance with TI's standard warranty. Testing and other quality control techniques are used to the extent TI deems necessary to support this warranty. Except where mandated by government requirements, testing of all parameters of each product is not necessarily performed.

TI assumes no liability for applications assistance or customer product design. Customers are responsible for their products and applications using TI components. To minimize the risks associated with customer products and applications, customers should provide adequate design and operating safeguards.

TI does not warrant or represent that any license, either express or implied, is granted under any TI patent right, copyright, mask work right, or other TI intellectual property right relating to any combination, machine, or process in which TI products or services are used. Information published by TI regarding third-party products or services does not constitute a license from TI to use such products or services or a warranty or endorsement thereof. Use of such information may require a license from a third party under the patents or other intellectual property of the third party, or a license from TI under the patents or other intellectual property of TI.

Reproduction of information in TI data books or data sheets is permissible only if reproduction is without alteration and is accompanied by all associated warranties, conditions, limitations, and notices. Reproduction of this information with alteration is an unfair and deceptive business practice. TI is not responsible or liable for such altered documentation.

Resale of TI products or services with statements different from or beyond the parameters stated by TI for that product or service voids all express and any implied warranties for the associated TI product or service and is an unfair and deceptive business practice. TI is not responsible or liable for any such statements.

Following are URLs where you can obtain information on other Texas Instruments products and application solutions:

Products		Applications	
Amplifiers	amplifier.ti.com	Audio	www.ti.com/audio
Data Converters	dataconverter.ti.com	Automotive	www.ti.com/automotive
DSP	dsp.ti.com	Broadband	www.ti.com/broadband
Interface	interface.ti.com	Digital Control	www.ti.com/digitalcontrol
Logic	logic.ti.com	Military	www.ti.com/military
Power Mgmt	power.ti.com	Optical Networking	www.ti.com/opticalnetwork
Microcontrollers	microcontroller.ti.com	Security	www.ti.com/security
		Telephony	www.ti.com/telephony
		Video & Imaging	www.ti.com/video
		Wireless	www.ti.com/wireless

Mailing Address: Texas Instruments
Post Office Box 655303 Dallas, Texas 75265

Looking for pricing, stock, or lifecycle information?

Click below to explore more details on WIN SOURCE:

 [View OPA660AP](#) on WIN SOURCE

 [Texas Instruments](#) Information

Optimize Your Supply Chain with WIN SOURCE Solutions

-  Global Sourcing Solution
-  Obsolete Management
-  Cost Control Management
-  Shortage Management
-  Alternative Solution
-  Excess Inventory Management