



# THE DATASHEET OF OPA2836IDGSR



# OPAx836 Very-Low-Power, Rail-to-Rail Out, Negative Rail In, Voltage-Feedback Operational Amplifiers

## 1 Features

- Low Power:
  - Supply Voltage: 2.5 V to 5.5 V
  - Quiescent Current: 1 mA (Typical)
  - Power Down Mode: 0.5  $\mu$ A (Typical)
- Bandwidth: 205 MHz
- Slew Rate: 560 V/ $\mu$ s
- Rise Time: 3 ns ( $2 V_{STEP}$ )
- Settling Time (0.1%): 22 ns ( $2 V_{STEP}$ )
- Overdrive Recovery Time: 60 ns
- SNR: 0.00013% ( $-117.6$  dBc) at 1 kHz ( $1 V_{RMS}$ )
- THD: 0.00003% ( $-130$  dBc) at 1 kHz ( $1 V_{RMS}$ )
- $HD_2/HD_3$ :  $-85$  dBc/ $-105$  dBc at 1 MHz ( $2 V_{PP}$ )
- Input Voltage Noise: 4.6 nV/ $\sqrt{Hz}$  ( $f = 100$  kHz)
- Input Offset Voltage: 65  $\mu$ V ( $\pm 400$ - $\mu$ V Maximum)
- CMRR: 116 dB
- Output Current Drive: 50 mA
- RRO: Rail-to-Rail Output
- Input Voltage Range:  $-0.2$  V to  $+3.9$  V (5-V Supply)
- Operating Temperature Range:  $-40^\circ\text{C}$  to  $+125^\circ\text{C}$

## 2 Applications

- Low-Power Signal Conditioning
- Audio ADC Input Buffers
- Low-Power SAR and  $\Delta\Sigma$  ADC Drivers
- Portable Systems
- Low-Power Systems
- High-Density Systems

## 3 Description

The OPA836 and OPA2836 devices (OPAx836) are single- and dual-channel, ultra-low power, rail-to-rail output, negative-rail input, voltage-feedback (VFB) operational amplifiers designed to operate over a power-supply range of 2.5 V to 5.5 V with a single supply, or  $\pm 1.25$  V to  $\pm 2.75$  V with a dual supply. Consuming only 1 mA per channel and a unity-gain bandwidth of 205 MHz, these amplifiers set an industry-leading power-to-performance ratio for rail-to-rail amplifiers.

For battery-powered, portable applications where power is of key importance, the low-power consumption and high-frequency performance of the OPA836 and OPA2836 devices offer performance-versus-power capability that is not attainable in other devices. Coupled with a power-savings mode to reduce current to  $< 1.5$   $\mu$ A, these devices offer an attractive solution for high-frequency amplifiers in battery-powered applications.

The OPA836 RUN package option includes integrated gain-setting resistors for the smallest possible footprint on a printed-circuit board (approximately 2.00 mm  $\times$  2.00 mm). By adding circuit traces on the PCB, gains of +1,  $-1$ ,  $-1.33$ , +2, +2.33,  $-3$ , +4,  $-4$ , +5,  $-5.33$ , +6.33,  $-7$ , +8 and inverting attenuations of  $-0.1429$ ,  $-0.1875$ ,  $-0.25$ ,  $-0.33$ ,  $-0.75$  can be achieved. See [Table 3](#) and [Table 4](#) for details.

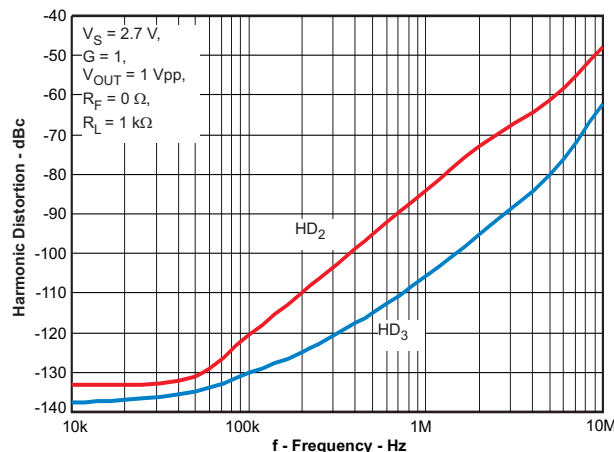
The OPA836 and OPA2836 devices are characterized for operation over the extended industrial temperature range of  $-40^\circ\text{C}$  to  $+125^\circ\text{C}$ .

### Device Information<sup>(1)</sup>

PART NUMBER	PACKAGE	BODY SIZE (NOM)
OPA836	SOT-23 (6)	2.90 mm $\times$ 1.60 mm
	WQFN (10)	2.00 mm $\times$ 2.00 mm
OPA2836	SOIC (8)	4.90 mm $\times$ 3.91 mm
	VSSOP (10)	3.00 mm $\times$ 3.00 mm
	UQFN (10)	2.00 mm $\times$ 2.00 mm
	WQFN (10)	2.00 mm $\times$ 2.00 mm

(1) For all available packages, see the package option addendum at the end of the data sheet.

### Harmonic Distortion vs Frequency



## Table of Contents

<b>1 Features</b> .....	1	8.3 Feature Description .....	24
<b>2 Applications</b> .....	1	8.4 Device Functional Modes .....	27
<b>3 Description</b> .....	1	<b>9 Application and Implementation</b> .....	30
<b>4 Revision History</b> .....	2	9.1 Application Information .....	30
<b>5 OPA836-Related Devices</b> .....	4	9.2 Typical Applications .....	36
<b>6 Pin Configuration and Functions</b> .....	4	<b>10 Power Supply Recommendations</b> .....	40
<b>7 Specifications</b> .....	6	<b>11 Layout</b> .....	40
7.1 Absolute Maximum Ratings .....	6	11.1 Layout Guidelines .....	40
7.2 ESD Ratings .....	6	11.2 Layout Example .....	41
7.3 Recommended Operating Conditions .....	6	<b>12 Device and Documentation Support</b> .....	42
7.4 Thermal Information: OPA836 .....	6	12.1 Device Support .....	42
7.5 Thermal Information: OPA2836 .....	7	12.2 Related Links .....	42
7.6 Electrical Characteristics: $V_S = 2.7\text{ V}$ .....	7	12.3 Receiving Notification of Documentation Updates .....	42
7.7 Electrical Characteristics: $V_S = 5\text{ V}$ .....	9	12.4 Community Resources .....	42
7.8 Typical Characteristics .....	12	12.5 Trademarks .....	42
<b>8 Detailed Description</b> .....	24	12.6 Electrostatic Discharge Caution .....	42
8.1 Overview .....	24	12.7 Glossary .....	42
8.2 Functional Block Diagrams .....	24	<b>13 Mechanical, Packaging, and Orderable Information</b> .....	43

## 4 Revision History

NOTE: Page numbers for previous revisions may differ from page numbers in the current version.

Changes from Revision H (September 2016) to Revision I	Page
• Changed text in sections throughout the data sheet to be more clear and concise .....	1
• Changed " $R_G = \infty\Omega$ (open)" to " $R_G = \text{open}$ " .....	32
• Changed "gain tracking is superior to using" to "gain drift is superior to the drift with" .....	33
• Changed "results in degraded harmonic distortion" to "increases the harmonic distortion" .....	37
• Deleted "A 10- $\Omega$ series resistor can be inserted between the capacitor and the noninverting pin to isolate the capacitance." .....	38

Changes from Revision G (October 2015) to Revision H	Page
• Changed "Type" column header to "I/O" on <i>Pin Functions</i> table .....	5
• Reformatted header rows in <i>Thermal Information: OPA836</i> and <i>Thermal Information: OPA2836</i> tables .....	6
• Reformatted <i>Thermal Information</i> table note .....	6
• Reformatted <i>Thermal Information</i> table note .....	7
• Deleted the word "linear" from Output section parameters in <i>Electrical Characteristics <math>V_S = 2.7\text{ V}</math></i> table .....	7
• Deleted the word "linear" from Output section parameters in <i>Electrical Characteristics <math>V_S = 5\text{ V}</math></i> table .....	9
• Reformatted <i>Development Support</i> subsection .....	42
• Reformatted <i>Related Documentation</i> section .....	42
• Added <i>Receiving Notification of Documentation Updates</i> section .....	42

Changes from Revision E (September 2013) to Revision F	Page
• Changed <i>Features</i> section .....	1
• Added <i>Pin Configuration and Functions</i> section, <i>ESD Ratings</i> table, <i>Feature Description</i> section, <i>Device Functional Modes</i> , <i>Application and Implementation</i> section, <i>Power Supply Recommendations</i> section, <i>Layout</i> section, <i>Device and Documentation Support</i> section, and <i>Mechanical, Packaging, and Orderable Information</i> section .....	1

• Changed <i>Device Comparison Table</i> .....	4
• Changed <i>Pin Functions</i> table .....	5
• Changed <i>Open Loop Gain vs Frequency</i> graph.....	15
• Changed <i>Input Referred Noise vs Frequency</i> graph .....	15
• Changed <i>Open Loop Gain vs Frequency</i> graph .....	21
• Changed <i>Input Referred Noise vs Frequency</i> graph.....	21

---

**Changes from Revision D (October 2011) to Revision E**
**Page**

• Added OPA2836 RMC package to document.....	1
• Added RMC pin definitions to <i>Pin Functions</i> table .....	5
• Deleted Packaging/Ordering Information table, leaving only note to POA.....	6
• Added OPA2836 RMC package to <i>Thermal Information</i> table.....	7

---

**Changes from Revision C (September 2011) to Revision D**
**Page**

• Removed Product Preview from OPA835IRUNT and OPA835IRUNR .....	4
• Removed Product Preview from OPA836IRUNT and OPA836IRUNR .....	6
• Changed typical value for resistor temperature coefficient parameter from TBD to < 10 .....	9
• Changed "quiescent operating current" parameter to "quiescent operating current per amplifier" .....	9
• Changed resistor temperature coefficient typical value from TBD to < 10.....	11
• Changed "quiescent operating current" to "quiescent operating current per amplifier" .....	11

---

**Changes from Revision B (May 2011) to Revision C**
**Page**

• Added the "The OPA836 RUN package..." text to the Description .....	1
• Removed Product Preview from all devices except OPA835IRUNT and OPA835IRUNR .....	4
• Removed Product Preview from all devices except OPA836IRUNT and OPA836IRUNR .....	6
• Changed typical value for channel to channel crosstalk (OPA2836) parameter from TBD to –120 dB.....	8
• Changed the common-mode rejection ratio minimum value from 94 dB to 91 dB.....	8
• Added Gain Setting Resistors (OPA836IRUN ONLY) parameter in <i>Electrical Characteristics</i> table .....	9
• Changed the quiescent operating current ( $T_A = 25^\circ\text{C}$ ) minimum value from 0.8 mA to 0.7 mA .....	9
• Changed the minimum value for power supply rejection ( $\pm\text{PSRR}$ ) parameter from 95 dB to 91 dB .....	9
• Changed the power-down pin bias current test condition from $\overline{\text{PD}} = 0.7\text{ V}$ to $\overline{\text{PD}} = 0.5\text{ V}$ .....	9
• Changed the power-down quiescent current test condition from $\overline{\text{PD}} = 0.7\text{ V}$ to $\overline{\text{PD}} = 0.5\text{ V}$ .....	9
• Changed typical value for channel to channel crosstalk (OPA2836) parameter from TBD to –120 dB.....	10
• Changed the Common-mode rejection ratio Min value From: 97 dB To: 94 dB .....	11
• Added GAIN SETTING RESISTORS (OPA836IRUN ONLY) parameter to <i>Electrical Characteristics</i> table .....	11
• Changed the quiescent operating current ( $T_A = 25^\circ\text{C}$ ) minimum value from 0.9 mA to 0.8 mA .....	11
• Changed the power supply rejection ( $\pm\text{PSRR}$ ) minimum value from: 97 dB to 94 dB.....	11
• Changed the Power-down quiescent current CONDITIONS From: $\overline{\text{PD}} = 0.7\text{ V}$ To: $\overline{\text{PD}} = 0.5\text{ V}$ .....	11
• Changed the Power-down quiescent current Conditions From: $\overline{\text{PD}} = 0.7\text{ V}$ To: $\overline{\text{PD}} = 0.5\text{ V}$ .....	11
• Added Figure Crosstalk vs Frequency .....	16
• Added <i>Crosstalk vs Frequency</i> figure.....	22
• Added section <i>Single Ended to Differential Amplifier</i> .....	31

**Changes from Revision A (March 2011) to Revision B****Page**

- 
- Changed OPA836 from product preview to production data..... [1](#)
-

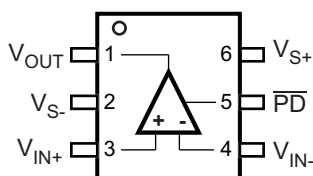
## 5 OPA836-Related Devices

DEVICE	BW ( $A_V = 1$ ) (MHz)	SLEW RATE ( $V/\mu s$ )	$I_q$ (+5 V) (mA)	INPUT NOISE ( $nV/\sqrt{Hz}$ )	RAIL-TO-RAIL IN/OUT	DUALS
OPA836	205	560	1	4.6	–VS/Out	OPA2836
OPA835	30	110	0.25	9.3	–VS/Out	OPA2835
OPA365	50	25	5	4.5	In/Out	OPA2365
THS4281	95	35	0.75	12.5	In/Out	
LMH6618	140	45	1.25	10	In/Out	LMH6619
OPA830	310	600	3.9	9.5	–VS/Out	OPA2830

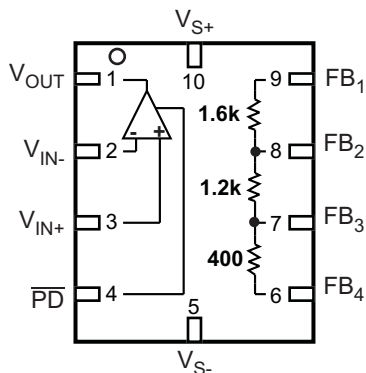
For a complete selection of TI High Speed Amplifiers, visit [ti.com](http://ti.com).

## 6 Pin Configuration and Functions

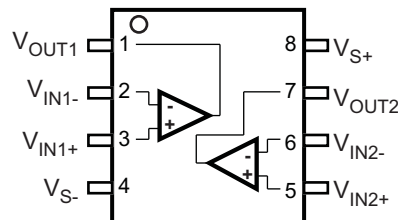
**OPA836 DBV Package  
6-Pin SOT-23  
Top View**



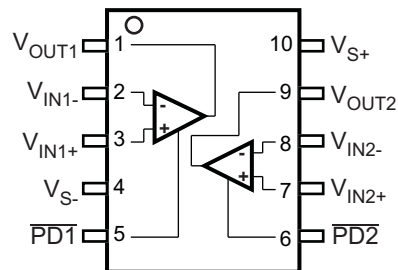
**OPA836 RUN Package  
10-Pin WQFN  
Top View**

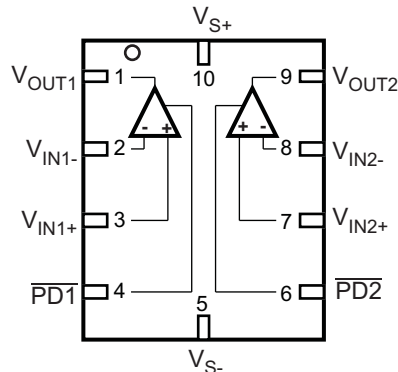


**OPA2836 D Package  
8-Pin SOIC  
Top View**



**OPA2836 DGS Package  
10-Pin VSSOP  
Top View**



**OPA2836 RUN, RMC Packages  
10-Pin WQFN, UQFN  
Top View**

**Pin Functions**

NAME	PIN					I/O	DESCRIPTION
	OPA836		OPA2836				
	SOT-23	WQFN	SOIC	VSSOP	WQFN, UQFN		
FB <sub>1</sub>	—	9	—	—	—	I/O	Connection to top of 2.4-kΩ internal gain setting resistors
FB <sub>2</sub>		8				I/O	Connection to junction of 1.8-kΩ and 2.4-kΩ internal gain setting resistors
FB <sub>3</sub>		7				I/O	Connection to junction of 600-Ω and 1.8-kΩ internal gain setting resistors
FB <sub>4</sub>		6				I/O	Connection to bottom of 600-Ω internal gain setting resistors
$\overline{\text{PD}}$	5	4	—	—	—	I	Amplifier Power Down, low = low-power mode, high = normal operation ( <b>PIN MUST BE DRIVEN</b> )
$\overline{\text{PD1}}$	—	—	—	5	4	I	Amplifier 1 Power Down, low = low-power mode, high = normal operation ( <b>PIN MUST BE DRIVEN</b> )
$\overline{\text{PD2}}$	—	—	—	6	6	I	Amplifier 2 Power Down, low = low-power mode, high = normal operation ( <b>PIN MUST BE DRIVEN</b> )
V <sub>IN+</sub>	3	3	—	—	—	I	Amplifier noninverting input
V <sub>IN-</sub>	4	2	—	—	—	I	Amplifier inverting input
V <sub>IN1+</sub>	—	—	3	3	3	I	Amplifier 1 noninverting input
V <sub>IN1-</sub>			2	2	2	I	Amplifier 1 inverting input
V <sub>IN2+</sub>			5	7	7	I	Amplifier 2 noninverting input
V <sub>IN2-</sub>			6	8	8	I	Amplifier 2 inverting input
V <sub>OUT</sub>	1	1	—	—	—	O	Amplifier output
V <sub>OUT1</sub>	—	—	1	1	1	O	Amplifier 1 output
V <sub>OUT2</sub>			7	9	9	O	Amplifier 2 output
V <sub>S+</sub>	6	10	8	10	10	POW	Positive power supply input
V <sub>S-</sub>	2	5	4	4	5	POW	Negative power supply input

## 7 Specifications

### 7.1 Absolute Maximum Ratings

over operating free-air temperature range (unless otherwise noted)<sup>(1)</sup>

		MIN	MAX	UNIT
$V_{S-}$ to $V_{S+}$	Supply voltage		5.5	V
$V_I$	Input voltage	$V_{S-} - 0.7$	$V_{S+} + 0.7$	V
$V_{ID}$	Differential input voltage		1	V
$I_I$	Continuous input current		0.85	mA
$I_O$	Continuous output current		60	mA
	Continuous power dissipation	See <a href="#">Thermal Information: OPA836</a> and <a href="#">Thermal Information: OPA2836</a>		
$T_J$	Maximum junction temperature		150	°C
$T_A$	Operating free-air temperature	-40	125	°C
$T_{stg}$	Storage temperature	-65	150	°C

- (1) Stresses beyond those listed under *Absolute Maximum Ratings* may cause permanent damage to the device. These are stress ratings only, which do not imply functional operation of the device at these or any other conditions beyond those indicated under *Recommended Operating Conditions*. Exposure to absolute-maximum-rated conditions for extended periods may affect device reliability.

### 7.2 ESD Ratings

		VALUE	UNIT
$V_{(ESD)}$	Electrostatic discharge	Human body model (HBM), per ANSI/ESDA/JEDEC JS-001 <sup>(1)</sup>	±6000
		Charged-device model (CDM), per JEDEC specification JESD22-C101 <sup>(2)</sup>	±1000
		Machine model	±200

- (1) JEDEC document JEP155 states that 500-V HBM allows safe manufacturing with a standard ESD control process.

- (2) JEDEC document JEP157 states that 250-V CDM allows safe manufacturing with a standard ESD control process.

### 7.3 Recommended Operating Conditions

over operating free-air temperature range (unless otherwise noted)

		MIN	NOM	MAX	UNIT
$V_{S+}$	Single supply voltage	2.5	5	5.5	V
$T_A$	Ambient temperature	-40	25	125	°C

### 7.4 Thermal Information: OPA836

THERMAL METRIC <sup>(1)</sup>	OPA836		UNIT	
	DBV (SOT23-6)	RUN (WQFN-10)		
	6 PINS	10 PINS		
$R_{\theta JA}$	Junction-to-ambient thermal resistance	194	145.8	°C/W
$R_{\theta JC(top)}$	Junction-to-case (top) thermal resistance	129.2	75.1	°C/W
$R_{\theta JB}$	Junction-to-board thermal resistance	39.4	38.9	°C/W
$\Psi_{JT}$	Junction-to-top characterization parameter	25.6	13.5	°C/W
$\Psi_{JB}$	Junction-to-board characterization parameter	38.9	104.5	°C/W

- (1) For more information about traditional and new thermal metrics, see [Semiconductor and IC Package Thermal Metrics](#) (SPRA953).

### 7.5 Thermal Information: OPA2836

THERMAL METRIC <sup>(1)</sup>		OPA2836				UNIT
		D (SOIC-8)	(DGS) VSSOP, MSOP-10	(RUN) WQFN-10	RMC (UQFN-10)	
		8 PINS	10 PINS	10 PINS	10 PINS	
R <sub>θJA</sub>	Junction-to-ambient thermal resistance	150.1	206	145.8	143.2	°C/W
R <sub>θJctop</sub>	Junction-to-case (top) thermal resistance	83.8	75.3	75.1	49.0	°C/W
R <sub>θJB</sub>	Junction-to-board thermal resistance	68.4	96.2	38.9	61.9	°C/W
ψ <sub>JT</sub>	Junction-to-top characterization parameter	33.0	12.9	13.5	3.3	°C/W
ψ <sub>JB</sub>	Junction-to-board characterization parameter	67.9	94.6	104.5	61.9	°C/W

(1) For more information about traditional and new thermal metrics, see [Semiconductor and IC Package Thermal Metrics](#) (SPRA953).

### 7.6 Electrical Characteristics: V<sub>S</sub> = 2.7 V

at V<sub>S+</sub> = +2.7 V, V<sub>S-</sub> = 0 V, V<sub>OUT</sub> = 1 V<sub>PP</sub>, R<sub>F</sub> = 0 Ω, R<sub>L</sub> = 2 kΩ, G = 1 V/V, input and output referenced to mid-supply, V<sub>IN,CM</sub> = mid-supply – 0.5 V. T<sub>A</sub> = 25°C, unless otherwise noted.

PARAMETER	TEST CONDITIONS	MIN	TYP	MAX	UNIT	TEST LEVEL <sup>(1)</sup>
<b>AC PERFORMANCE</b>						
Small-signal bandwidth	V <sub>OUT</sub> = 100 mV <sub>PP</sub> , G = 1		200		MHz	C
	V <sub>OUT</sub> = 100 mV <sub>PP</sub> , G = 2		100			
	V <sub>OUT</sub> = 100 mV <sub>PP</sub> , G = 5		26			
	V <sub>OUT</sub> = 100 mV <sub>PP</sub> , G = 10		11			
Gain-bandwidth product	V <sub>OUT</sub> = 100 mV <sub>PP</sub> , G = 10		110		MHz	C
Large-signal bandwidth	V <sub>OUT</sub> = 1 V <sub>PP</sub> , G = 2		60		MHz	C
Bandwidth for 0.1-dB flatness	V <sub>OUT</sub> = 1 V <sub>PP</sub> , G = 2		25		MHz	C
Slew rate, rise	V <sub>OUT</sub> = 1 V <sub>STEP</sub> , G = 2		260		V/μs	C
Slew rate, fall	V <sub>OUT</sub> = 1 V <sub>STEP</sub> , G = 2		240		V/μs	C
Rise time	V <sub>OUT</sub> = 1 V <sub>STEP</sub> , G = 2		4		ns	C
Fall time	V <sub>OUT</sub> = 1 V <sub>STEP</sub> , G = 2		4.5		ns	C
Settling time to 1%, rise	V <sub>OUT</sub> = 1 V <sub>STEP</sub> , G = 2		15		ns	C
Settling time to 1%, fall	V <sub>OUT</sub> = 1 V <sub>STEP</sub> , G = 2		15		ns	C
Settling time to 0.1%, rise	V <sub>OUT</sub> = 1 V <sub>STEP</sub> , G = 2		30		ns	C
Settling time to 0.1%, fall	V <sub>OUT</sub> = 1 V <sub>STEP</sub> , G = 2		25		ns	C
Settling time to 0.01%, rise	V <sub>OUT</sub> = 1 V <sub>STEP</sub> , G = 2		50		ns	C
Settling time to 0.01%, fall	V <sub>OUT</sub> = 1 V <sub>STEP</sub> , G = 2		45		ns	C
Overshoot/Undershoot	V <sub>OUT</sub> = 1 V <sub>STEP</sub> , G = 2		5%/3%			C
Second-order harmonic distortion	f = 10 kHz, V <sub>IN,CM</sub> = mid-supply – 0.5 V		-133		dBc	C
	f = 100 kHz, V <sub>IN,CM</sub> = mid-supply – 0.5 V		-120			C
	f = 1 MHz, V <sub>IN,CM</sub> = mid-supply – 0.5 V		-84			C
Third-order harmonic distortion	f = 10 kHz, V <sub>IN,CM</sub> = mid-supply – 0.5 V		-137		dBc	C
	f = 100 kHz, V <sub>IN,CM</sub> = mid-supply – 0.5 V		-130			C
	f = 1 MHz, V <sub>IN,CM</sub> = mid-supply – 0.5 V		-105			C
Second-order intermodulation distortion	f = 1 MHz, 200-kHz Tone Spacing, V <sub>OUT</sub> Envelope = 1 V <sub>PP</sub> V <sub>IN,CM</sub> = mid-supply – 0.5 V		-90		dBc	C
Third-order intermodulation distortion	f = 1 MHz, 200-kHz Tone Spacing, V <sub>OUT</sub> Envelope = 1 V <sub>PP</sub> V <sub>IN,CM</sub> = mid-supply – 0.5 V		-90		dBc	C
Input voltage noise	f = 100 KHz		4.6		nV/√Hz	C
Voltage noise 1/f corner frequency			215		Hz	C
Input current noise	f = 1 MHz		0.75		pA/√Hz	C

(1) Test levels (all values set by characterization and simulation): **(A)** 100% tested at 25°C; over temperature limits by characterization and simulation. **(B)** Not tested in production; limits set by characterization and simulation. **(C)** Typical value only for information.

**Electrical Characteristics:  $V_S = 2.7\text{ V}$  (continued)**

at  $V_{S+} = +2.7\text{ V}$ ,  $V_{S-} = 0\text{ V}$ ,  $V_{OUT} = 1\text{ V}_{PP}$ ,  $R_F = 0\ \Omega$ ,  $R_L = 2\text{ k}\Omega$ ,  $G = 1\text{ V/V}$ , input and output referenced to mid-supply,  $V_{IN,CM} = \text{mid-supply} - 0.5\text{ V}$ .  $T_A = 25^\circ\text{C}$ , unless otherwise noted.

PARAMETER	TEST CONDITIONS	MIN	TYP	MAX	UNIT	TEST LEVEL <sup>(1)</sup>
<b>AC PERFORMANCE (continued)</b>						
Current noise 1/f corner frequency			31.7		kHz	C
Overdrive recovery time, over/under	Overdrive = 0.5 V		55/60		ns	C
Closed-loop output impedance	f = 100 kHz		0.02		$\Omega$	C
Channel-to-channel crosstalk (OPA2836)	f = 10 kHz		-120		dB	C
<b>DC PERFORMANCE</b>						
Open-loop voltage gain ( $A_{OL}$ )		100	125		dB	A
Input referred offset voltage	$T_A = 25^\circ\text{C}$	-400	$\pm 65$	400	$\mu\text{V}$	A
	$T_A = 0^\circ\text{C}$ to $70^\circ\text{C}$	-680		680		B
	$T_A = -40^\circ\text{C}$ to $85^\circ\text{C}$	-760		760		
	$T_A = -40^\circ\text{C}$ to $125^\circ\text{C}$	-1060		1060		
Input offset voltage drift <sup>(2)</sup>	$T_A = 0^\circ\text{C}$ to $70^\circ\text{C}$	-6.2	$\pm 1$	6.2	$\mu\text{V}/^\circ\text{C}$	B
	$T_A = -40^\circ\text{C}$ to $85^\circ\text{C}$	-6	$\pm 1$	6		
	$T_A = -40^\circ\text{C}$ to $125^\circ\text{C}$	-6.6	$\pm 1.1$	6.6		
Input bias current <sup>(3)</sup>	$T_A = 25^\circ\text{C}$	300	650	1000	nA	A
	$T_A = 0^\circ\text{C}$ to $70^\circ\text{C}$	190		1400		B
	$T_A = -40^\circ\text{C}$ to $85^\circ\text{C}$	120		1500		
	$T_A = -40^\circ\text{C}$ to $125^\circ\text{C}$	120		1800		
Input bias current drift <sup>(2)</sup>	$T_A = 0^\circ\text{C}$ to $70^\circ\text{C}$	-2	$\pm 0.33$	2	nA/ $^\circ\text{C}$	B
	$T_A = -40^\circ\text{C}$ to $85^\circ\text{C}$	-1.9	$\pm 0.32$	1.9		
	$T_A = -40^\circ\text{C}$ to $125^\circ\text{C}$	-2.1	$\pm 0.37$	2.1		
Input offset current	$T_A = 25^\circ\text{C}$	-180	$\pm 30$	180	nA	A
	$T_A = 0^\circ\text{C}$ to $70^\circ\text{C}$	-200	$\pm 30$	200		B
	$T_A = -40^\circ\text{C}$ to $85^\circ\text{C}$	-215	$\pm 30$	215		
	$T_A = -40^\circ\text{C}$ to $125^\circ\text{C}$	-240	$\pm 30$	240		
Input offset current drift <sup>(2)</sup>	$T_A = 0^\circ\text{C}$ to $70^\circ\text{C}$	-460	$\pm 77$	460	pA/ $^\circ\text{C}$	B
	$T_A = -40^\circ\text{C}$ to $85^\circ\text{C}$	-575	$\pm 95$	575		
	$T_A = -40^\circ\text{C}$ to $125^\circ\text{C}$	-600	$\pm 100$	600		
<b>INPUT</b>						
Common-mode input range low	$T_A = 25^\circ\text{C}$ , < 3-dB degradation in CMRR limit		-0.2	0	V	A
	$T_A = -40^\circ\text{C}$ to $125^\circ\text{C}$ , < 3-dB degradation in CMRR limit		-0.2	0	V	B
Common-mode input range high	$T_A = 25^\circ\text{C}$ , < 3-dB degradation in CMRR limit	1.5	1.6		V	A
	$T_A = -40^\circ\text{C}$ to $125^\circ\text{C}$ , < 3-dB degradation in CMRR limit	1.5	1.6		V	B
Input operating voltage range	$T_A = 25^\circ\text{C}$ , < 6-dB degradation in THD		-0.3 to 1.75		V	C
Common-mode rejection ratio		91	114		dB	A
Input impedance common-mode			200    1.2		k $\Omega$    pF	C
Input impedance differential mode			200    1		k $\Omega$    pF	C

- (2) Input Offset Voltage Drift, Input Bias Current Drift, and Input Offset Current Drift are average values calculated by taking data at the end points, computing the difference, and dividing by the temperature range.
- (3) Current is considered positive out of the pin.

**Electrical Characteristics:  $V_S = 2.7\text{ V}$  (continued)**

at  $V_{S+} = +2.7\text{ V}$ ,  $V_{S-} = 0\text{ V}$ ,  $V_{OUT} = 1\text{ V}_{PP}$ ,  $R_F = 0\ \Omega$ ,  $R_L = 2\text{ k}\Omega$ ,  $G = 1\text{ V/V}$ , input and output referenced to mid-supply,  $V_{IN,CM} = \text{mid-supply} - 0.5\text{ V}$ .  $T_A = 25^\circ\text{C}$ , unless otherwise noted.

PARAMETER	TEST CONDITIONS	MIN	TYP	MAX	UNIT	TEST LEVEL <sup>(1)</sup>
<b>OUTPUT</b>						
Output voltage low	$T_A = 25^\circ\text{C}$ , $G = 5$		0.15	0.2	V	A
	$T_A = -40^\circ\text{C}$ to $125^\circ\text{C}$ , $G = 5$		0.15	0.2	V	B
Output voltage high	$T_A = 25^\circ\text{C}$ , $G = 5$	2.45	2.5		V	A
	$T_A = -40^\circ\text{C}$ to $125^\circ\text{C}$ , $G = 5$	2.45	2.5		V	B
Output saturation voltage, high/low	$T_A = 25^\circ\text{C}$ , $G = 5$		80/40		mV	C
Output current drive	$T_A = 25^\circ\text{C}$	$\pm 40$	$\pm 45$		mA	A
	$T_A = -40^\circ\text{C}$ to $125^\circ\text{C}$	$\pm 40$	$\pm 45$		mA	B
<b>GAIN SETTING RESISTORS (OPA836IRUN ONLY)</b>						
Resistor FB1 to FB2	DC resistance	1584	1600	1616	$\Omega$	A
Resistor FB2 to FB3	DC resistance	1188	1200	1212	$\Omega$	A
Resistor FB3 to FB4	DC resistance	396	400	404	$\Omega$	A
Resistor tolerance	DC resistance	-1%		1%		A
Resistor temperature coefficient	DC resistance		<10		PPM	C
<b>POWER SUPPLY</b>						
Specified operating voltage		2.5		5.5	V	B
Quiescent operating current per amplifier	$T_A = 25^\circ\text{C}$	0.7	0.95	1.15	mA	A
	$T_A = -40^\circ\text{C}$ to $125^\circ\text{C}$	0.6		1.4	mA	B
Power supply rejection ( $\pm\text{PSRR}$ )		91	108		dB	A
<b>POWER DOWN</b>						
Enable voltage threshold	Specified "on" above $V_{S-} + 2.1\text{ V}$			2.1	V	A
Disable voltage threshold	Specified "off" below $V_{S-} + 0.7\text{ V}$	0.7			V	A
Power-down pin bias current	$\overline{\text{PD}} = 0.5\text{ V}$		20	500	nA	A
Power-down quiescent current	$\overline{\text{PD}} = 0.5\text{ V}$		0.5	1.5	$\mu\text{A}$	A
Turnon time delay	Time from $\overline{\text{PD}} = \text{high}$ to $V_{OUT} = 90\%$ of final value		200		ns	C
Turnoff time delay	Time from $\overline{\text{PD}} = \text{low}$ to $V_{OUT} = 10\%$ of original value		25		ns	C

**7.7 Electrical Characteristics:  $V_S = 5\text{ V}$** 

at  $V_{S+} = +5\text{ V}$ ,  $V_{S-} = 0\text{ V}$ ,  $V_{OUT} = 2\text{ V}_{PP}$ ,  $R_F = 0\ \Omega$ ,  $R_L = 1\text{ k}\Omega$ ,  $G = 1\text{ V/V}$ , input and output referenced to mid-supply.  $T_A = 25^\circ\text{C}$ , unless otherwise noted.

PARAMETER	TEST CONDITIONS	MIN	TYP	MAX	UNIT	TEST LEVEL <sup>(1)</sup>
<b>AC PERFORMANCE</b>						
Small-signal bandwidth	$V_{OUT} = 100\text{ mV}_{PP}$ , $G = 1$		205		MHz	C
	$V_{OUT} = 100\text{ mV}_{PP}$ , $G = 2$		100			
	$V_{OUT} = 100\text{ mV}_{PP}$ , $G = 5$		28			
	$V_{OUT} = 100\text{ mV}_{PP}$ , $G = 10$		11.8			
Gain-bandwidth product	$V_{OUT} = 100\text{ mV}_{PP}$ , $G = 10$		118		MHz	C
Large-signal bandwidth	$V_{OUT} = 2\text{ V}_{PP}$ , $G = 2$		87		MHz	C
Bandwidth for 0.1-dB flatness	$V_{OUT} = 2\text{ V}_{PP}$ , $G = 2$		29		MHz	C
Slew rate, rise	$V_{OUT} = 2\text{-V Step}$ , $G = 2$		560		V/ $\mu\text{s}$	C
Slew rate, fall	$V_{OUT} = 2\text{-V Step}$ , $G = 2$		580		V/ $\mu\text{s}$	C
Rise time	$V_{OUT} = 2\text{-V Step}$ , $G = 2$		3		ns	C
Fall time	$V_{OUT} = 2\text{-V Step}$ , $G = 2$		3		ns	C

(1) Test levels (all values set by characterization and simulation): **(A)** 100% tested at  $25^\circ\text{C}$ ; over temperature limits by characterization and simulation. **(B)** Not tested in production; limits set by characterization and simulation. **(C)** Typical value only for information.

**Electrical Characteristics:  $V_S = 5\text{ V}$  (continued)**

at  $V_{S+} = +5\text{ V}$ ,  $V_{S-} = 0\text{ V}$ ,  $V_{OUT} = 2\text{ V}_{PP}$ ,  $R_F = 0\ \Omega$ ,  $R_L = 1\text{ k}\Omega$ ,  $G = 1\text{ V/V}$ , input and output referenced to mid-supply.  $T_A = 25^\circ\text{C}$ , unless otherwise noted.

PARAMETER	TEST CONDITIONS	MIN	TYP	MAX	UNIT	TEST LEVEL <sup>(1)</sup>
<b>AC PERFORMANCE (continued)</b>						
Settling time to 1%, rise	$V_{OUT} = 2\text{-V Step}$ , $G = 2$		22		ns	C
Settling time to 1%, fall	$V_{OUT} = 2\text{-V Step}$ , $G = 2$		22		ns	C
Settling time to 0.1%, rise	$V_{OUT} = 2\text{-V Step}$ , $G = 2$		30		ns	C
Settling time to 0.1%, fall	$V_{OUT} = 2\text{-V Step}$ , $G = 2$		30		ns	C
Settling time to 0.01%, rise	$V_{OUT} = 2\text{-V Step}$ , $G = 2$		40		ns	C
Settling time to 0.01%, fall	$V_{OUT} = 2\text{-V Step}$ , $G = 2$		45		ns	C
Overshoot/Undershoot	$V_{OUT} = 2\text{-V Step}$ , $G = 2$		7.5%/5%			C
Second-order harmonic distortion	$f = 10\text{ kHz}$		-133		dBc	C
	$f = 100\text{ kHz}$		-120			
	$f = 1\text{ MHz}$		-85			
Third-order harmonic distortion	$f = 10\text{ kHz}$		-140		dBc	C
	$f = 100\text{ kHz}$		-130			
	$f = 1\text{ MHz}$		-105			
Second-order intermodulation distortion	$f = 1\text{ MHz}$ , 200 kHz Tone Spacing, $V_{OUT}$ Envelope = $2\text{ V}_{PP}$		-79		dBc	C
Third-order intermodulation distortion	$f = 1\text{ MHz}$ , 200 kHz Tone Spacing, $V_{OUT}$ Envelope = $2\text{ V}_{PP}$		-91		dBc	C
Signal-to-noise ratio, SNR	$f = 1\text{ kHz}$ , $V_{OUT} = 1\text{ V}_{RMS}$ , 22 kHz bandwidth		0.00013%		dBc	C
			-117.6			
Total harmonic distortion, THD	$f = 1\text{ kHz}$ , $V_{OUT} = 1\text{ V}_{RMS}$		0.00003%		dBc	C
			-130			
Input voltage noise	$f = 100\text{ KHz}$		4.6		nV/ $\sqrt{\text{Hz}}$	C
Voltage noise 1/f corner frequency			215		Hz	C
Input current noise	$f > 1\text{ MHz}$		0.75		pA/ $\sqrt{\text{Hz}}$	C
Current noise 1/f corner frequency			31.7		kHz	C
Overdrive recovery time, over/under	Overdrive = 0.5 V		55/60		ns	C
Closed-loop output impedance	$f = 100\text{ kHz}$		0.02		$\Omega$	C
Channel to channel crosstalk (OPA2836)	$f = 10\text{ kHz}$		-120		dB	C
<b>DC PERFORMANCE</b>						
Open-loop voltage gain ( $A_{OL}$ )		100	122		dB	A
Input referred offset voltage	$T_A = 25^\circ\text{C}$	-400	$\pm 65$	400	$\mu\text{V}$	A
	$T_A = 0^\circ\text{C to } 70^\circ\text{C}$	-685		685		B
	$T_A = -40^\circ\text{C to } 85^\circ\text{C}$	-765		765		
	$T_A = -40^\circ\text{C to } 125^\circ\text{C}$	-1080		1080		
Input offset voltage drift <sup>(2)</sup>	$T_A = 0^\circ\text{C to } 70^\circ\text{C}$	-6.3	$\pm 1.05$	6.3	$\mu\text{V}/^\circ\text{C}$	B
	$T_A = -40^\circ\text{C to } 85^\circ\text{C}$	-6.1	$\pm 1$	6.1		
	$T_A = -40^\circ\text{C to } 125^\circ\text{C}$	-6.8	$\pm 1.1$	6.8		
Input bias current <sup>(3)</sup>	$T_A = 25^\circ\text{C}$	300	650	1000	nA	A
	$T_A = 0^\circ\text{C to } 70^\circ\text{C}$	190		1400		B
	$T_A = -40^\circ\text{C to } 85^\circ\text{C}$	120		1550		
	$T_A = -40^\circ\text{C to } 125^\circ\text{C}$	120		1850		
Input bias current drift <sup>(2)</sup>	$T_A = 0^\circ\text{C to } 70^\circ\text{C}$		$\pm 0.34$	$\pm 2$	nA/ $^\circ\text{C}$	B
	$T_A = -40^\circ\text{C to } 85^\circ\text{C}$		$\pm 0.34$	$\pm 2$		
	$T_A = -40^\circ\text{C to } 125^\circ\text{C}$		$\pm 0.38$	$\pm 2.3$		

(2) Input Offset Voltage Drift, Input Bias Current Drift, and Input Offset Current Drift are average values calculated by taking data at the end points, computing the difference, and dividing by the temperature range.

(3) Current is considered positive out of the pin.

**Electrical Characteristics:  $V_S = 5\text{ V}$  (continued)**

at  $V_{S+} = +5\text{ V}$ ,  $V_{S-} = 0\text{ V}$ ,  $V_{OUT} = 2 V_{PP}$ ,  $R_F = 0\ \Omega$ ,  $R_L = 1\text{ k}\Omega$ ,  $G = 1\text{ V/V}$ , input and output referenced to mid-supply.  $T_A = 25^\circ\text{C}$ , unless otherwise noted.

PARAMETER	TEST CONDITIONS	MIN	TYP	MAX	UNIT	TEST LEVEL <sup>(1)</sup>
<b>DC PERFORMANCE (continued)</b>						
Input offset current	$T_A = 25^\circ\text{C}$		$\pm 30$	$\pm 180$	nA	A
	$T_A = 0^\circ\text{C to } 70^\circ\text{C}$		$\pm 30$	$\pm 200$		B
	$T_A = -40^\circ\text{C to } 85^\circ\text{C}$		$\pm 30$	$\pm 215$		
	$T_A = -40^\circ\text{C to } 125^\circ\text{C}$		$\pm 30$	$\pm 250$		
Input offset current drift <sup>(2)</sup>	$T_A = 0^\circ\text{C to } 70^\circ\text{C}$		$\pm 80$	$\pm 480$	pA/ $^\circ\text{C}$	B
	$T_A = -40^\circ\text{C to } 85^\circ\text{C}$		$\pm 100$	$\pm 600$		
	$T_A = -40^\circ\text{C to } 125^\circ\text{C}$		$\pm 110$	$\pm 660$		
<b>INPUT</b>						
Common-mode input range low	$T_A = 25^\circ\text{C}$ , < 3-dB degradation in CMRR limit		-0.2	0	V	A
	$T_A = -40^\circ\text{C to } 125^\circ\text{C}$ , < 3-dB degradation in CMRR limit		-0.2	0	V	B
Common-mode input range high	$T_A = 25^\circ\text{C}$ , < 3-dB degradation in CMRR limit	3.8	3.9		V	A
	$T_A = -40^\circ\text{C to } 125^\circ\text{C}$ , < 3-dB degradation in CMRR limit	3.8	3.9		V	B
Input linear operating voltage range	$T_A = 25^\circ\text{C}$ , < 6-dB degradation in THD		-0.3 to 4.05		V	C
Common-mode rejection ratio		94	116		dB	A
Input impedance common mode			200    1.2		k $\Omega$    pF	C
Input impedance differential mode			200    1		k $\Omega$    pF	C
<b>OUTPUT</b>						
Output voltage low	$T_A = 25^\circ\text{C}$ , $G = 5$		0.15	0.2	V	A
	$T_A = -40^\circ\text{C to } 125^\circ\text{C}$ , $G = 5$		0.15	0.2	V	B
Output voltage high	$T_A = 25^\circ\text{C}$ , $G = 5$	4.75	4.8		V	A
	$T_A = -40^\circ\text{C to } 125^\circ\text{C}$ , $G = 5$	4.75	4.8		V	B
Output saturation voltage, high/low	$T_A = 25^\circ\text{C}$ , $G = 5$		100/50		mV	C
Output current drive	$T_A = 25^\circ\text{C}$	$\pm 40$	$\pm 50$		mA	A
	$T_A = -40^\circ\text{C to } 125^\circ\text{C}$	$\pm 40$	$\pm 50$		mA	B
<b>GAIN SETTING RESISTORS (OPA836IRUN ONLY)</b>						
Resistor FB1 to FB2	DC resistance	1584	1600	1616	$\Omega$	A
Resistor FB2 to FB3	DC resistance	1188	1200	1212	$\Omega$	A
Resistor FB3 to FB4	DC resistance	396	400	404	$\Omega$	A
Resistor tolerance	DC resistance	-1		1%		A
Resistor temperature coefficient	DC resistance		<10		PPM	C
<b>POWER SUPPLY</b>						
Specified operating voltage		2.5		5.5	V	B
Quiescent operating current per amplifier	$T_A = 25^\circ\text{C}$	0.8	1.0	1.2	mA	A
	$T_A = -40^\circ\text{C to } 125^\circ\text{C}$	0.65		1.5	mA	B
Power supply rejection ( $\pm$ PSRR)		94	108		dB	A
<b>POWER DOWN</b>						
Enable voltage threshold	Specified "on" above $V_{S-} + 2.1\text{ V}$			2.1	V	A
Disable voltage threshold	Specified "off" below $V_{S-} + 0.7\text{ V}$	0.7			V	A
Power-down pin bias current	$\overline{\text{PD}} = 0.5\text{ V}$		20	500	nA	A
Power-down quiescent current	$\overline{\text{PD}} = 0.5\text{ V}$		0.5	1.5	$\mu\text{A}$	A
Turnon time delay	Time from $\overline{\text{PD}} = \text{high}$ to $V_{OUT} = 90\%$ of final value		170		ns	C
Turnoff time delay	Time from $\overline{\text{PD}} = \text{low}$ to $V_{OUT} = 10\%$ of original value		35		ns	C

## 7.8 Typical Characteristics

### 7.8.1 Typical Characteristics: $V_S = 2.7\text{ V}$

**Table 1. Table of Graphs**

FIGURE TITLE		FIGURE LOCATION
Small Signal Frequency Response		<a href="#">Figure 1</a>
Large Signal Frequency Response		<a href="#">Figure 2</a>
Noninverting Pulse Response		<a href="#">Figure 3</a>
Inverting Pulse Response		<a href="#">Figure 4</a>
Slew Rate	vs Output Voltage Step	<a href="#">Figure 5</a>
Output Overdrive Recovery		<a href="#">Figure 6</a>
Harmonic Distortion	vs Frequency	<a href="#">Figure 7</a>
Harmonic Distortion	vs Load Resistance	<a href="#">Figure 8</a>
Harmonic Distortion	vs Output Voltage	<a href="#">Figure 9</a>
Harmonic Distortion	vs Gain	<a href="#">Figure 10</a>
Output Voltage Swing	vs Load Resistance	<a href="#">Figure 11</a>
Output Saturation Voltage	vs Load Current	<a href="#">Figure 12</a>
Output Impedance	vs Frequency	<a href="#">Figure 13</a>
Frequency Response With Capacitive Load		<a href="#">Figure 14</a>
Series Output Resistor	vs Capacitive Load	<a href="#">Figure 17</a>
Input Referred Noise	vs Frequency	<a href="#">Figure 16</a>
Open Loop Gain	vs Frequency	<a href="#">Figure 15</a>
Common Mode/Power Supply Rejection Ratios	vs Frequency	<a href="#">Figure 18</a>
Crosstalk	vs Frequency	<a href="#">Figure 19</a>
Power Down Response		<a href="#">Figure 20</a>
Input Offset Voltage		<a href="#">Figure 23</a>
Input Offset Voltage	vs Free-Air Temperature	<a href="#">Figure 21</a>
Input Offset Voltage Drift		<a href="#">Figure 48</a>
Input Offset Current		<a href="#">Figure 24</a>
Input Offset Current	vs Free-Air Temperature	<a href="#">Figure 25</a>
Input Offset Current Drift		<a href="#">Figure 26</a>

at  $V_{S+} = +2.7\text{ V}$ ,  $V_{S-} = 0\text{ V}$ ,  $V_{OUT} = 1\text{ V}_{pp}$ ,  $R_F = 0\ \Omega$ ,  $R_L = 2\text{ k}\Omega$ ,  $G = 1\text{ V/V}$ , input and output referenced to mid-supply,  $V_{IN\_CM} = \text{mid-supply} - 0.5\text{ V}$ .  $T_A = 25^\circ\text{C}$ , unless otherwise noted.

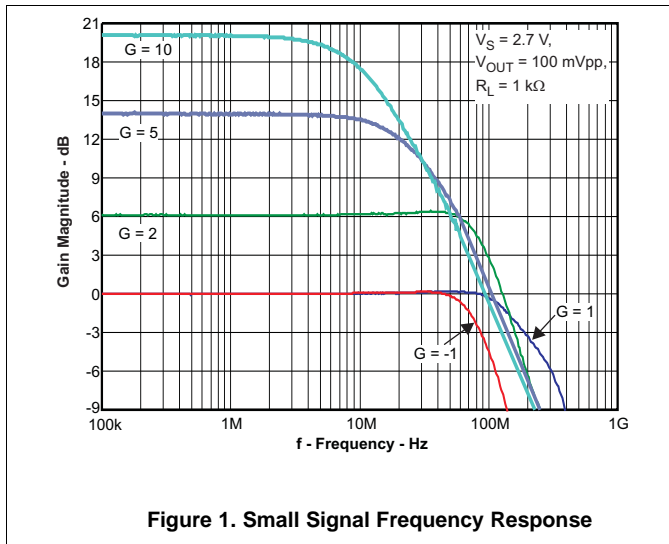


Figure 1. Small Signal Frequency Response

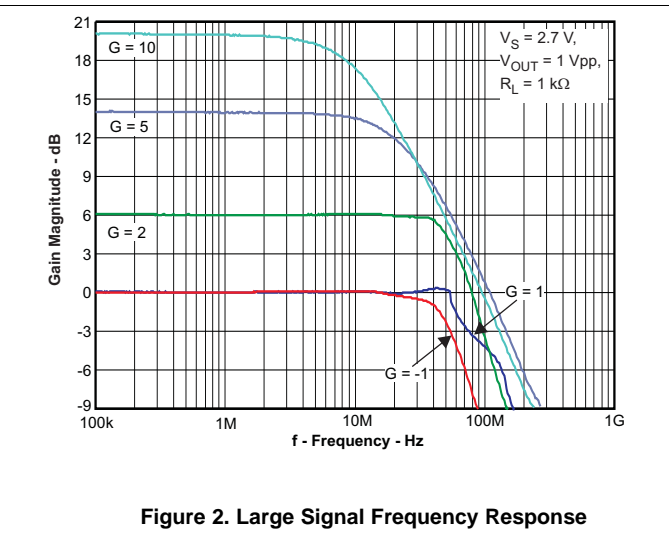


Figure 2. Large Signal Frequency Response

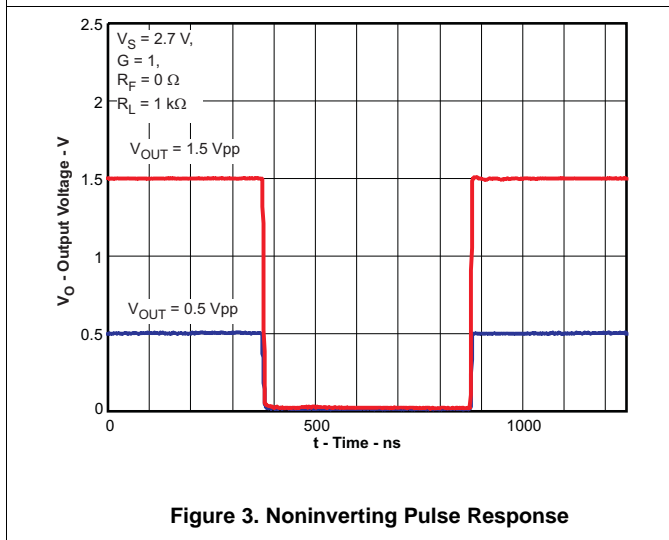


Figure 3. Noninverting Pulse Response

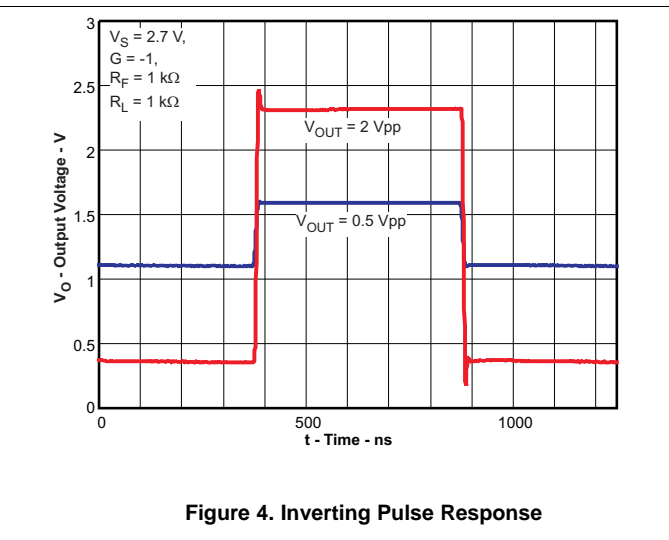


Figure 4. Inverting Pulse Response

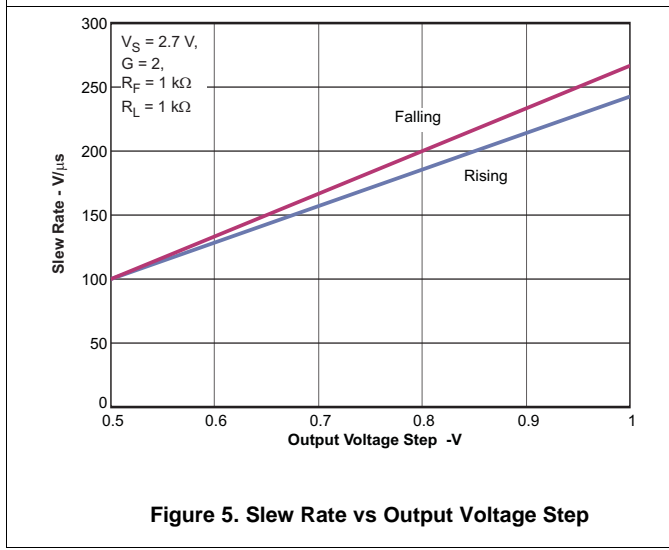


Figure 5. Slew Rate vs Output Voltage Step

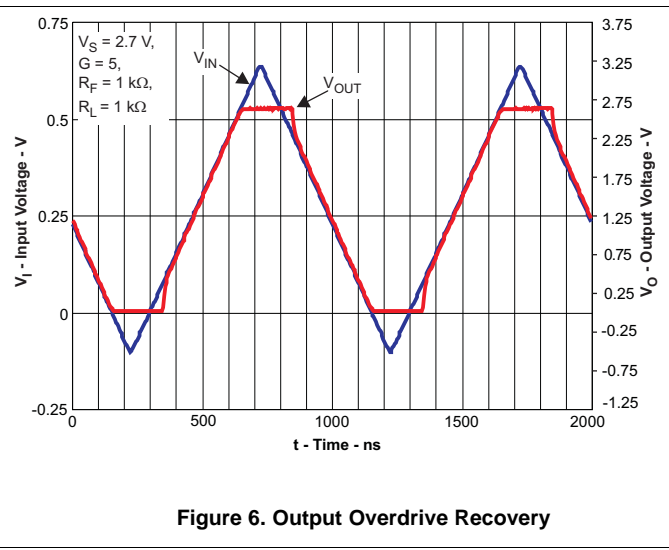


Figure 6. Output Overdrive Recovery

at  $V_{S+} = +2.7\text{ V}$ ,  $V_{S-} = 0\text{ V}$ ,  $V_{OUT} = 1\text{ V}_{pp}$ ,  $R_F = 0\ \Omega$ ,  $R_L = 2\text{ k}\Omega$ ,  $G = 1\text{ V/V}$ , input and output referenced to mid-supply,  $V_{IN\_CM} = \text{mid-supply} - 0.5\text{ V}$ .  $T_A = 25^\circ\text{C}$ , unless otherwise noted.

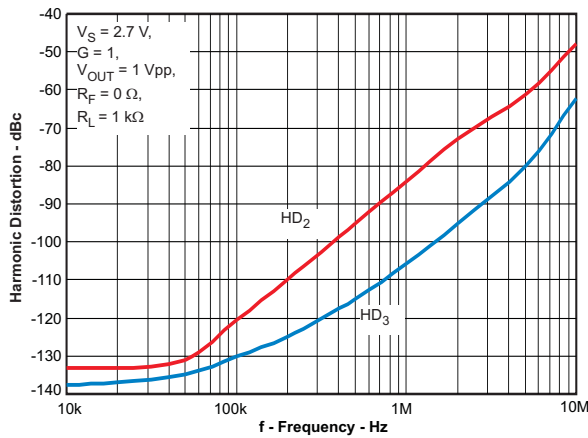


Figure 7. Harmonic Distortion vs Frequency

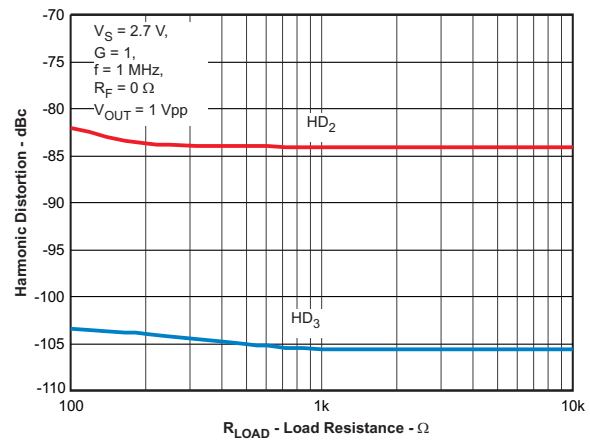


Figure 8. Harmonic Distortion vs Load Resistance

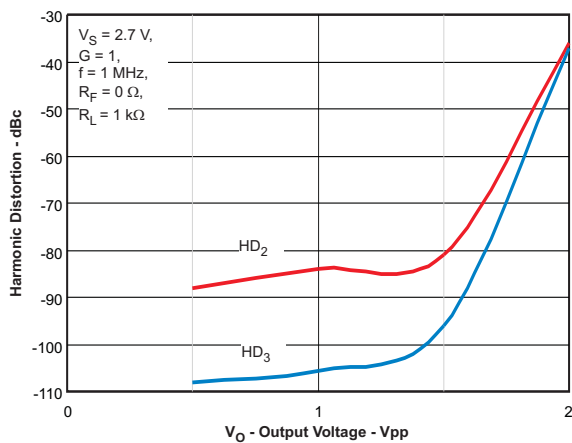


Figure 9. Harmonic Distortion vs Output Voltage

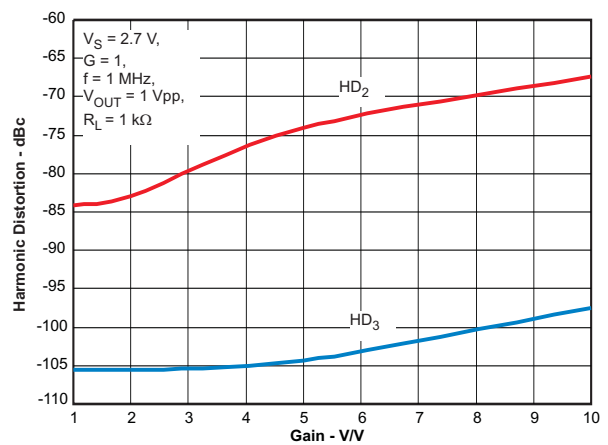


Figure 10. Harmonic Distortion vs Gain

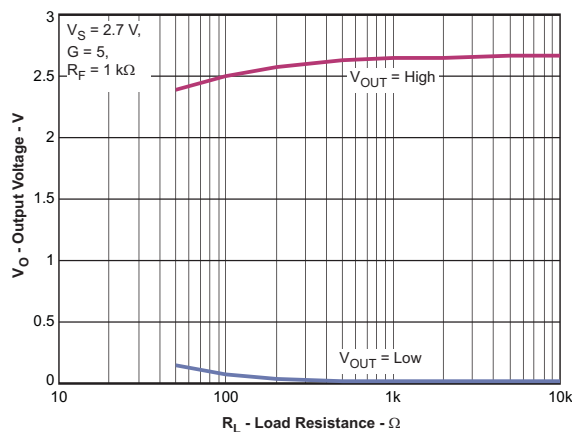


Figure 11. Output Voltage Swing vs Load Resistance

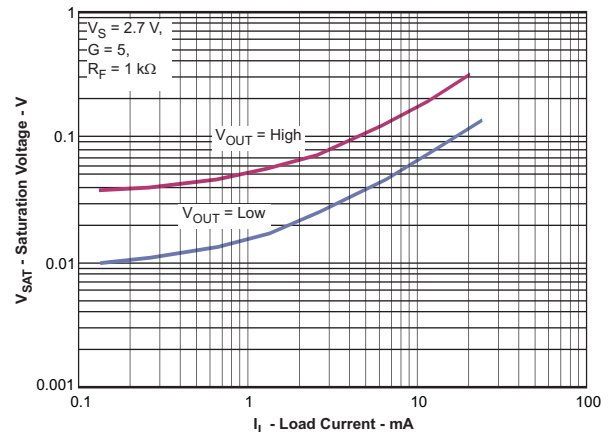


Figure 12. Output Saturation Voltage vs Load Current

OPA836, OPA2836

SLOS712I – JANUARY 2011 – REVISED OCTOBER 2016

www.ti.com

at  $V_{S+} = +2.7\text{ V}$ ,  $V_{S-} = 0\text{ V}$ ,  $V_{OUT} = 1\text{ V}_{pp}$ ,  $R_F = 0\ \Omega$ ,  $R_L = 2\text{ k}\Omega$ ,  $G = 1\text{ V/V}$ , input and output referenced to mid-supply,  $V_{IN\_CM} = \text{mid-supply} - 0.5\text{ V}$ .  $T_A = 25^\circ\text{C}$ , unless otherwise noted.

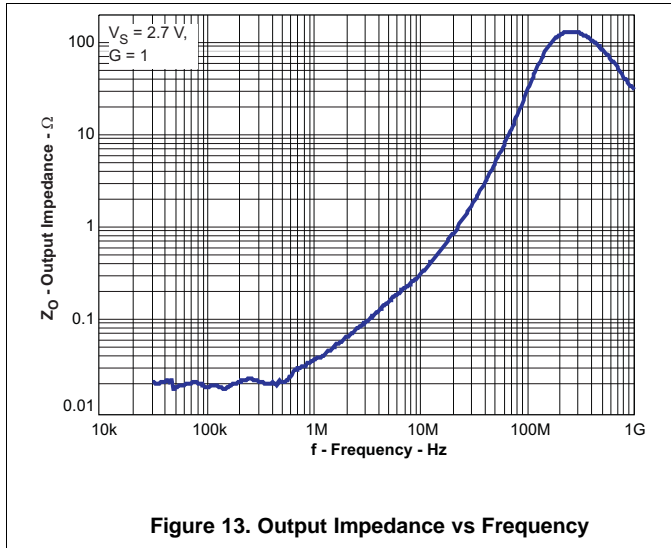


Figure 13. Output Impedance vs Frequency

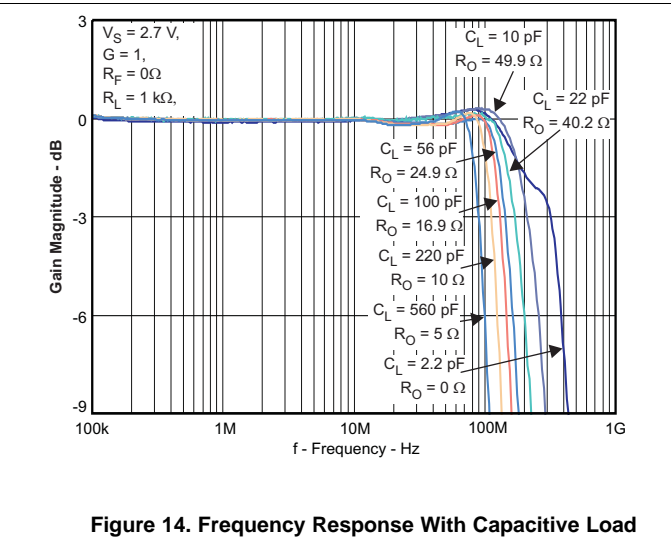


Figure 14. Frequency Response With Capacitive Load

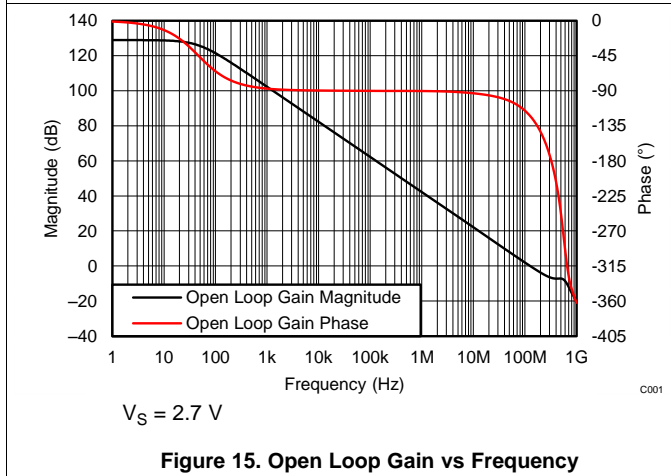


Figure 15. Open Loop Gain vs Frequency

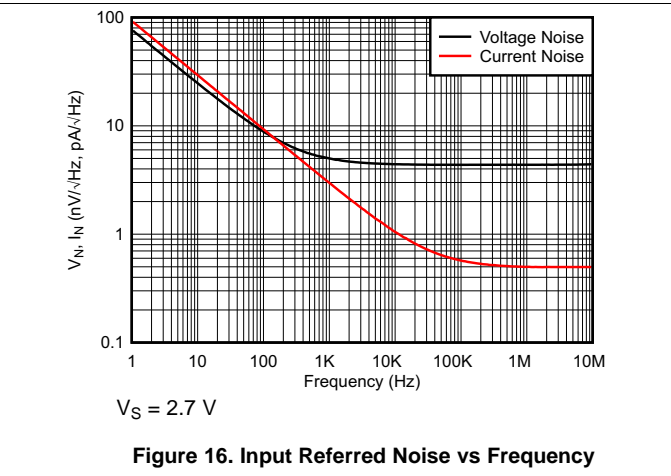


Figure 16. Input Referred Noise vs Frequency

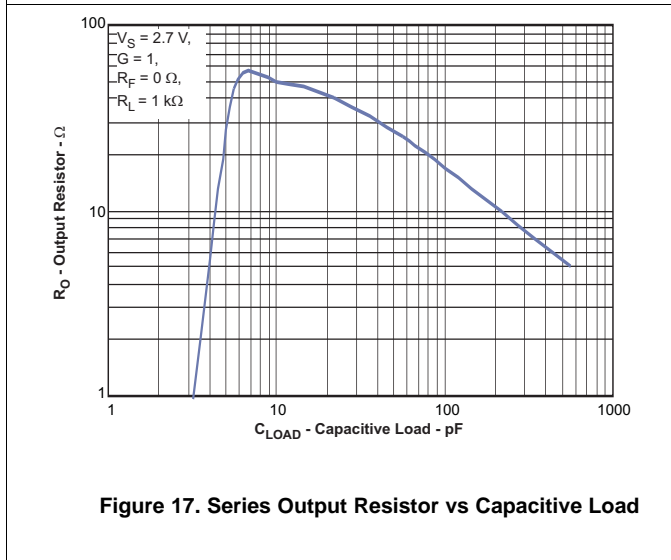


Figure 17. Series Output Resistor vs Capacitive Load

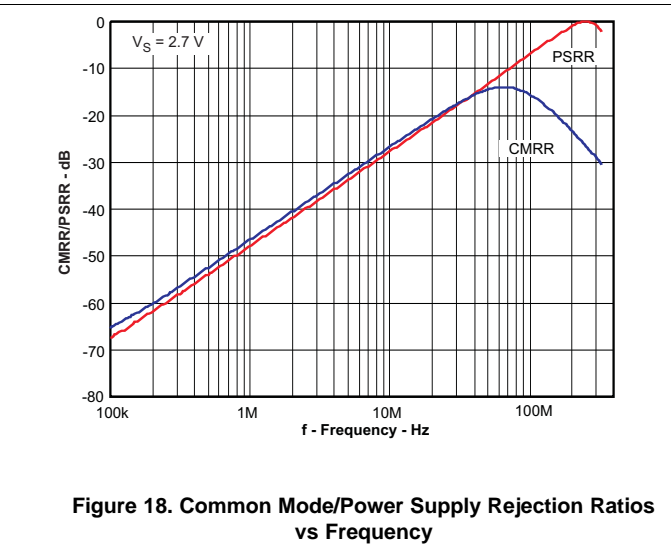


Figure 18. Common Mode/Power Supply Rejection Ratios vs Frequency

at  $V_{S+} = +2.7\text{ V}$ ,  $V_{S-} = 0\text{ V}$ ,  $V_{OUT} = 1\text{ V}_{pp}$ ,  $R_F = 0\ \Omega$ ,  $R_L = 2\text{ k}\Omega$ ,  $G = 1\text{ V/V}$ , input and output referenced to mid-supply,  $V_{IN\_CM} = \text{mid-supply} - 0.5\text{ V}$ .  $T_A = 25^\circ\text{C}$ , unless otherwise noted.

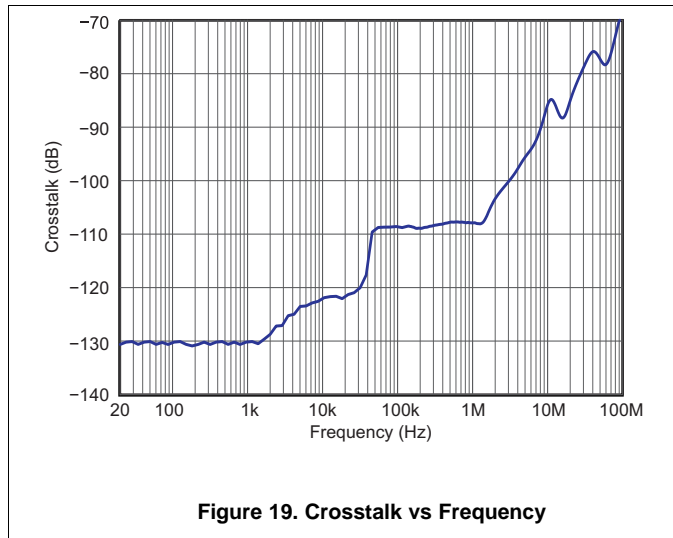


Figure 19. Crosstalk vs Frequency

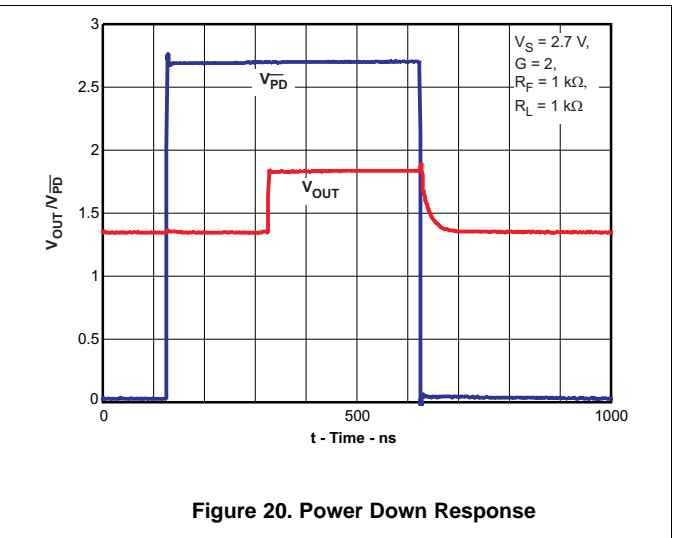


Figure 20. Power Down Response

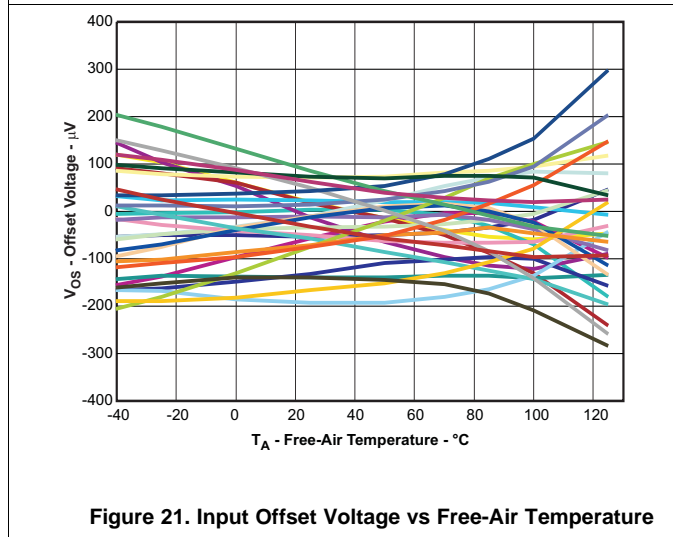


Figure 21. Input Offset Voltage vs Free-Air Temperature

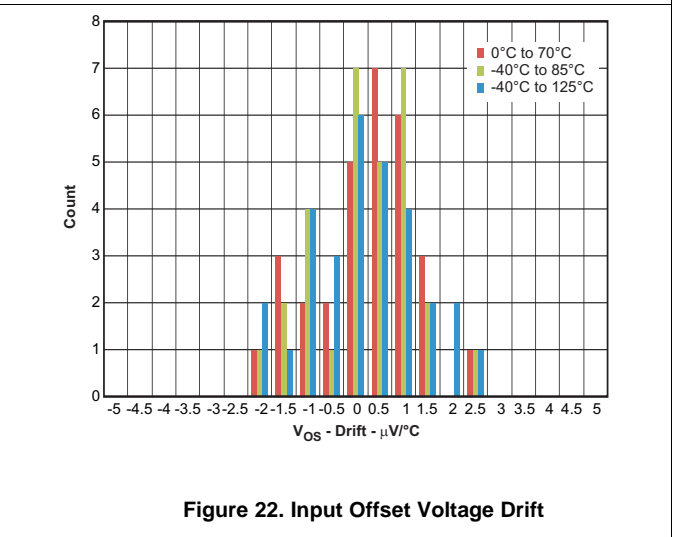


Figure 22. Input Offset Voltage Drift

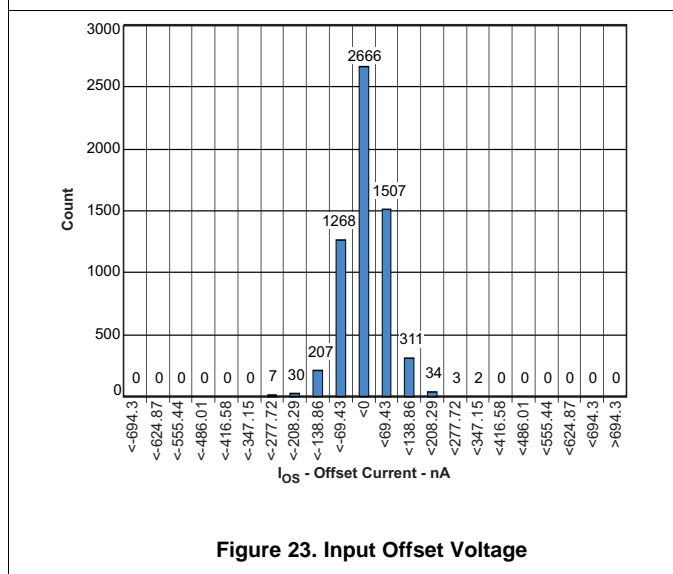


Figure 23. Input Offset Current

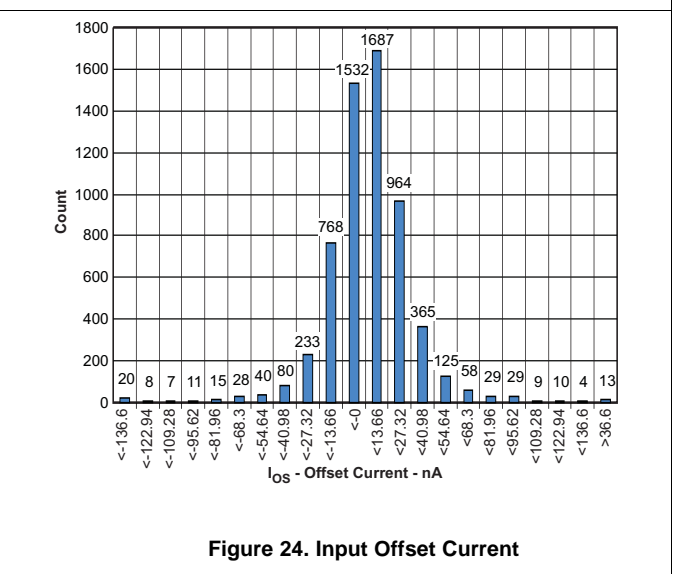


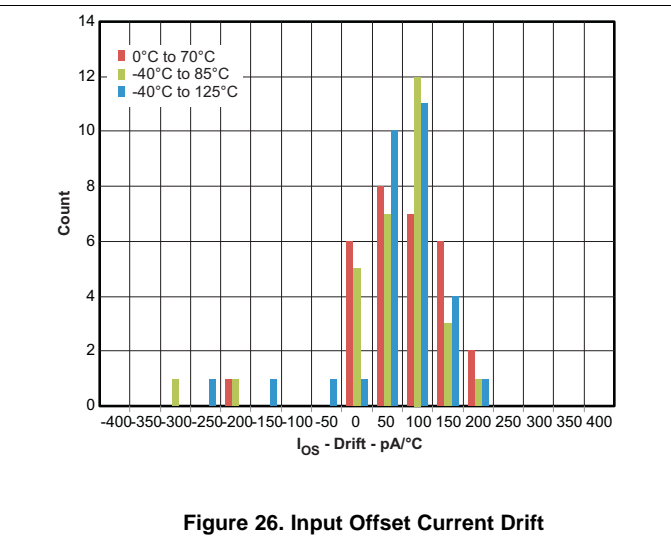
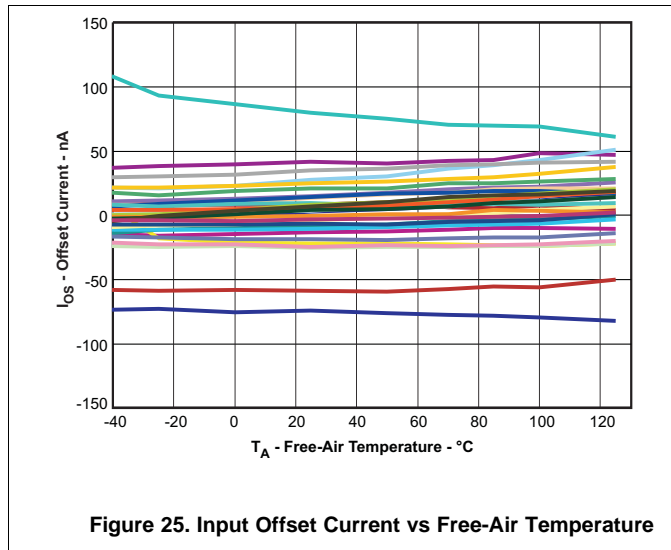
Figure 24. Input Offset Current

**OPA836, OPA2836**

SLOS712I – JANUARY 2011 – REVISED OCTOBER 2016

www.ti.com

at  $V_{S+} = +2.7\text{ V}$ ,  $V_{S-} = 0\text{ V}$ ,  $V_{OUT} = 1\text{ V}_{pp}$ ,  $R_F = 0\ \Omega$ ,  $R_L = 2\text{ k}\Omega$ ,  $G = 1\text{ V/V}$ , input and output referenced to mid-supply,  $V_{IN\_CM} = \text{mid-supply} - 0.5\text{ V}$ .  $T_A = 25^\circ\text{C}$ , unless otherwise noted.



**7.8.2 Typical Performance Graphs:  $V_S = 5\text{ V}$** 
**Table 2. Table of Graphs**

FIGURE TITLE		FIGURE LOCATION
Small Signal Frequency Response		<a href="#">Figure 27</a>
Large Signal Frequency Response		<a href="#">Figure 28</a>
Noninverting Pulse Response		<a href="#">Figure 29</a>
Inverting Pulse Response		<a href="#">Figure 30</a>
Slew Rate	vs Output Voltage Step	<a href="#">Figure 31</a>
Output Overdrive Recovery		<a href="#">Figure 32</a>
Harmonic Distortion	vs Frequency	<a href="#">Figure 33</a>
Harmonic Distortion	vs Load Resistance	<a href="#">Figure 34</a>
Harmonic Distortion	vs Output Voltage	<a href="#">Figure 35</a>
Harmonic Distortion	vs Gain	<a href="#">Figure 36</a>
Output Voltage Swing	vs Load Resistance	<a href="#">Figure 37</a>
Output Saturation Voltage	vs Load Current	<a href="#">Figure 38</a>
Output Impedance	vs Frequency	<a href="#">Figure 39</a>
Frequency Response With Capacitive Load		<a href="#">Figure 40</a>
Series Output Resistor	vs Capacitive Load	<a href="#">Figure 43</a>
Input Referred Noise	vs Frequency	<a href="#">Figure 41</a>
Open Loop Gain	vs Frequency	<a href="#">Figure 42</a>
Common Mode/Power Supply Rejection Ratios	vs Frequency	<a href="#">Figure 44</a>
Crosstalk	vs Frequency	<a href="#">Figure 45</a>
Power Down Response		<a href="#">Figure 46</a>
Input Offset Voltage		<a href="#">Figure 49</a>
Input Offset Voltage	vs Free-Air Temperature	<a href="#">Figure 47</a>
Input Offset Voltage Drift		<a href="#">Figure 48</a>
Input Offset Current		<a href="#">Figure 50</a>
Input Offset Current	vs Free-Air Temperature	<a href="#">Figure 51</a>
Input Offset Current Drift		<a href="#">Figure 52</a>

at  $V_{S+} = +5\text{ V}$ ,  $V_{S-} = 0\text{ V}$ ,  $V_{OUT} = 2\text{ V}_{PP}$ ,  $R_F = 0\ \Omega$ ,  $R_L = 1\text{ k}\Omega$ ,  $G = 1\text{ V/V}$ , input and output referenced to mid-supply unless otherwise noted.  $T_A = 25^\circ\text{C}$ , unless otherwise noted.

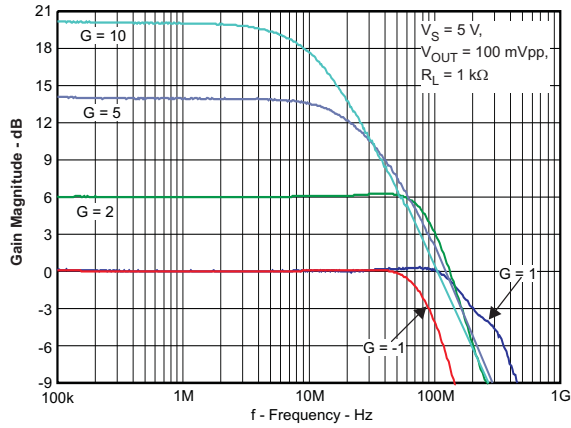


Figure 27. Small Signal Frequency Response

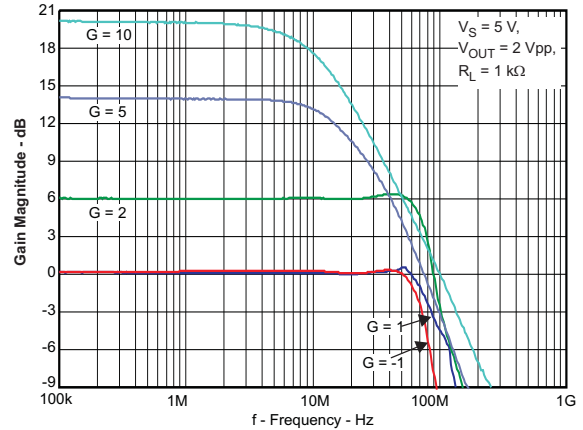


Figure 28. Large Signal Frequency Response

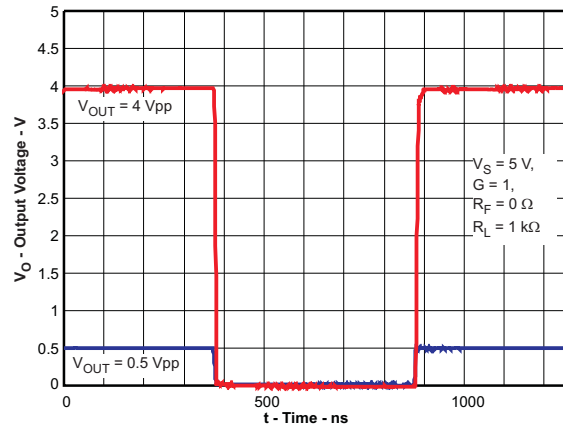


Figure 29. Noninverting Pulse Response

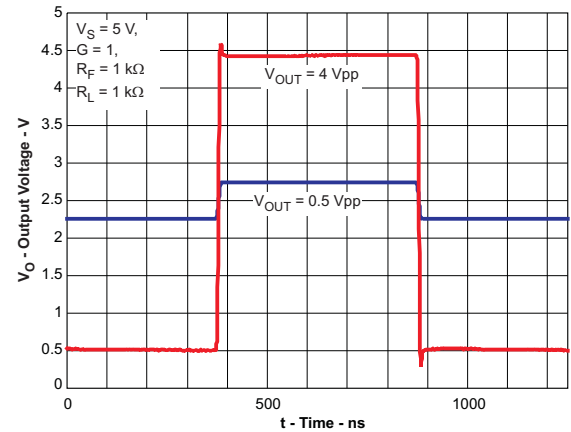


Figure 30. Inverting Pulse Response

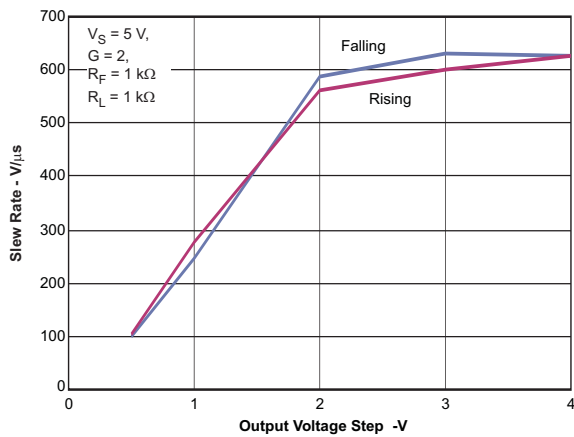


Figure 31. Slew Rate vs Output Voltage Step

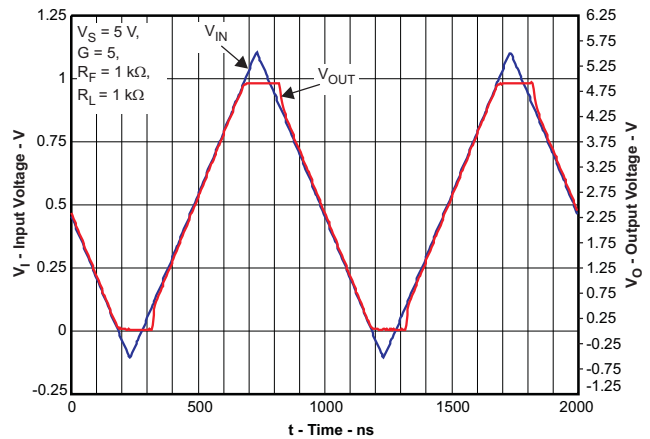
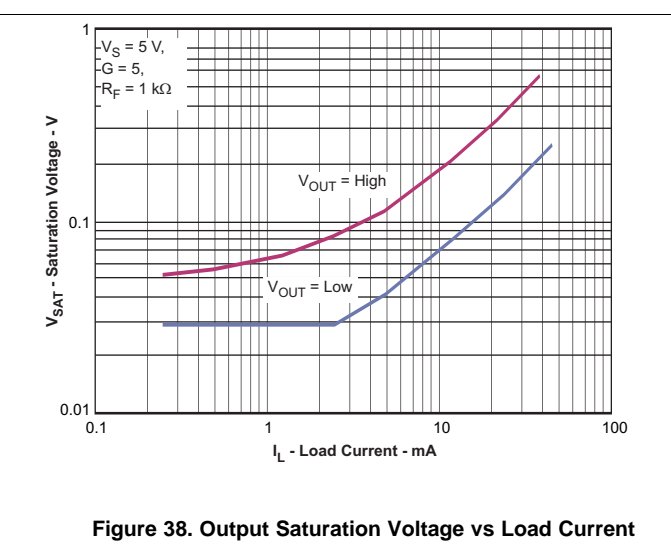
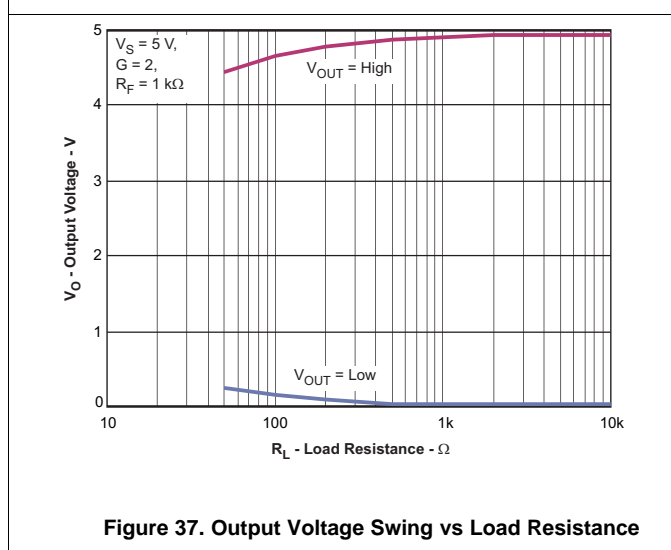
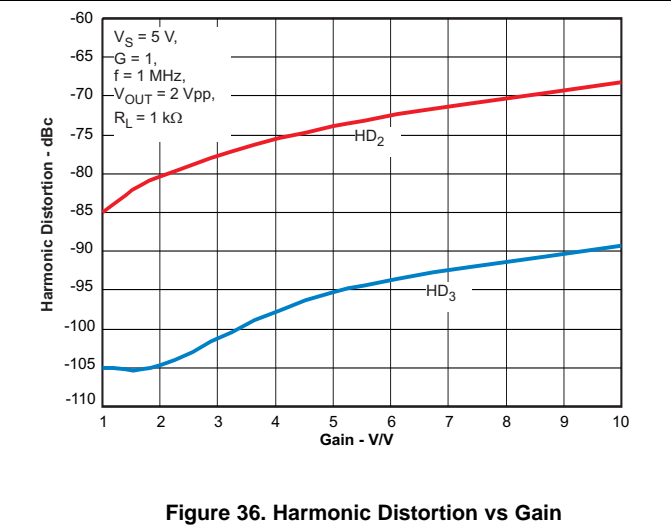
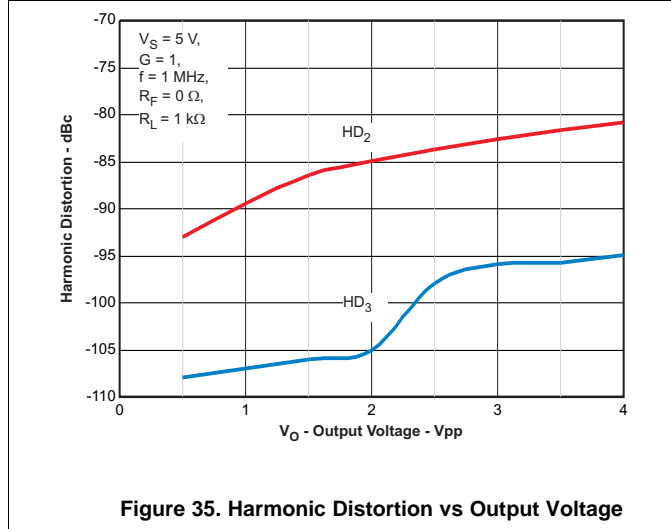
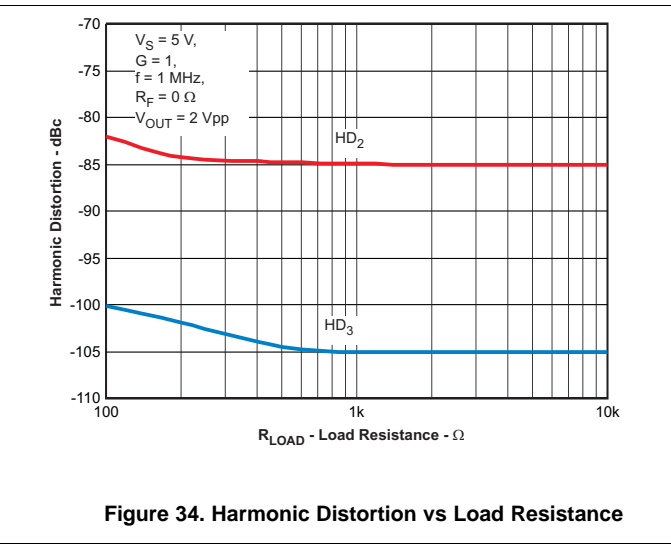
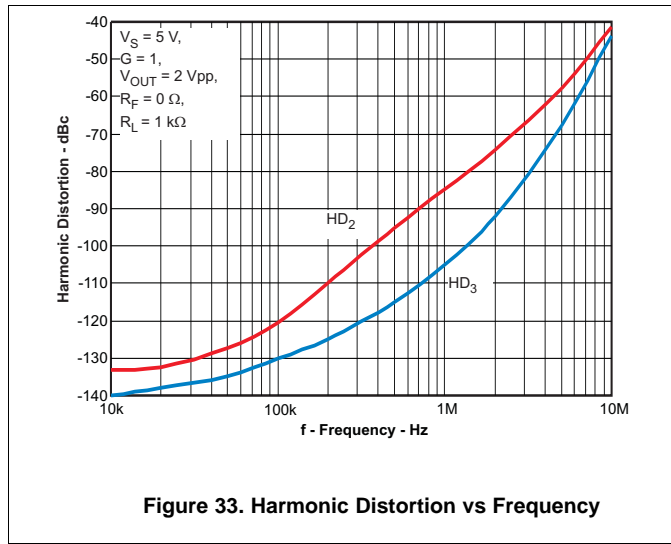


Figure 32. Output Overdrive Recovery

at  $V_{S+} = +5\text{ V}$ ,  $V_{S-} = 0\text{ V}$ ,  $V_{OUT} = 2\text{ V}_{PP}$ ,  $R_F = 0\ \Omega$ ,  $R_L = 1\text{ k}\Omega$ ,  $G = 1\text{ V/V}$ , input and output referenced to mid-supply unless otherwise noted.  $T_A = 25^\circ\text{C}$ , unless otherwise noted.



at  $V_{S+} = +5\text{ V}$ ,  $V_{S-} = 0\text{ V}$ ,  $V_{OUT} = 2\text{ V}_{PP}$ ,  $R_F = 0\ \Omega$ ,  $R_L = 1\text{ k}\Omega$ ,  $G = 1\text{ V/V}$ , input and output referenced to mid-supply unless otherwise noted.  $T_A = 25^\circ\text{C}$ , unless otherwise noted.

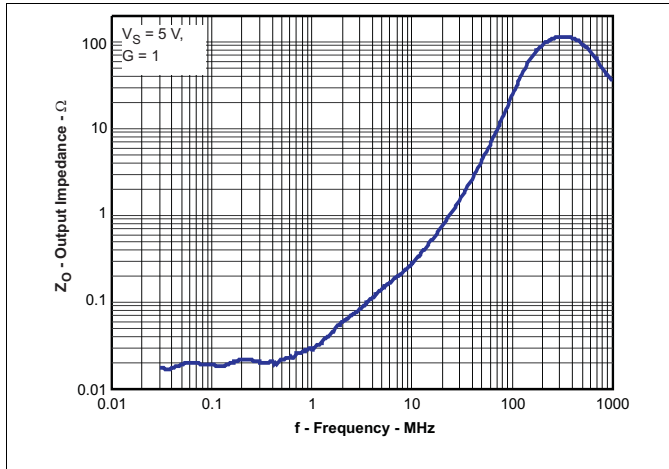


Figure 39. Output Impedance vs Frequency

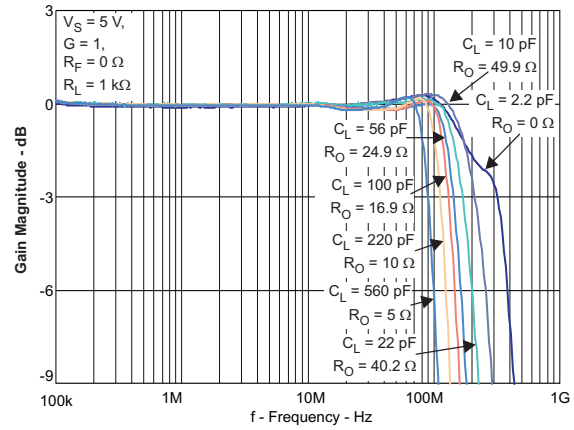


Figure 40. Frequency Response With Capacitive Load

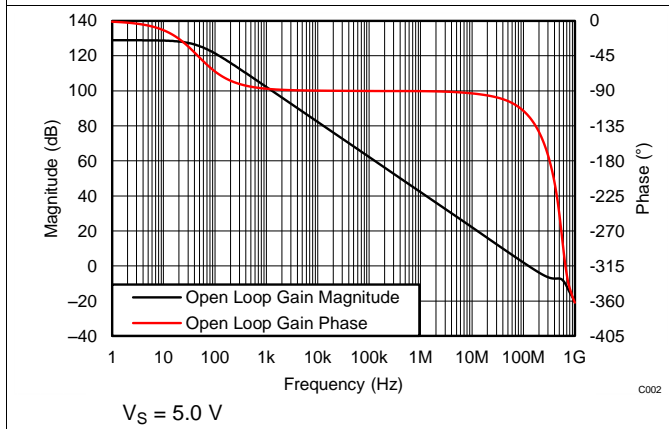


Figure 41. Open Loop Gain vs Frequency

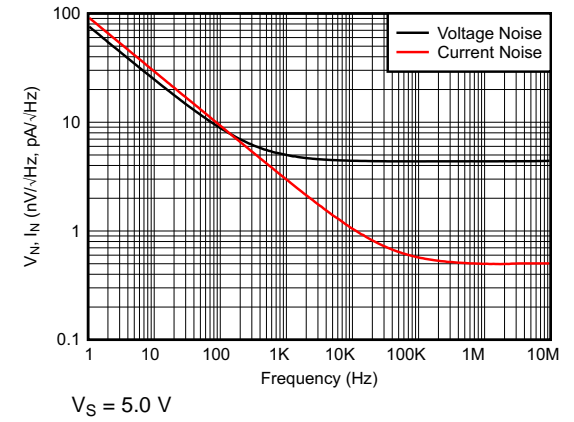


Figure 42. Input Referred Noise vs Frequency

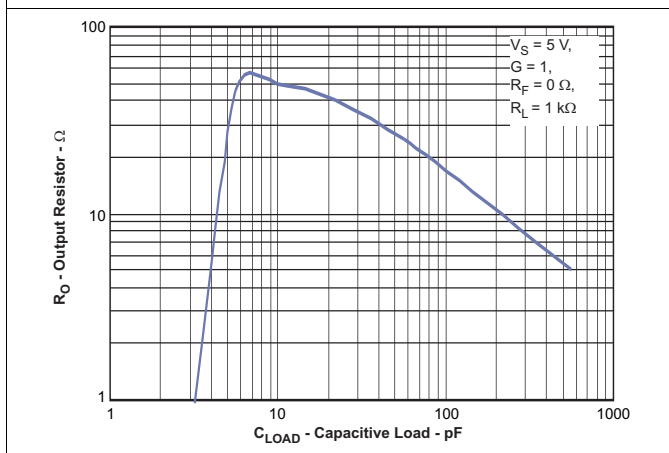


Figure 43. Series Output Resistor vs Capacitive Load

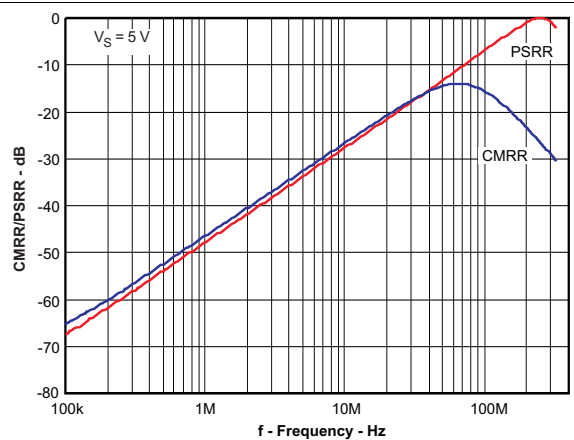


Figure 44. Common-Mode/Power Supply Rejection Ratios vs Frequency

at  $V_{S+} = +5\text{ V}$ ,  $V_{S-} = 0\text{ V}$ ,  $V_{OUT} = 2 V_{PP}$ ,  $R_F = 0\ \Omega$ ,  $R_L = 1\text{ k}\Omega$ ,  $G = 1\text{ V/V}$ , input and output referenced to mid-supply unless otherwise noted.  $T_A = 25^\circ\text{C}$ , unless otherwise noted.

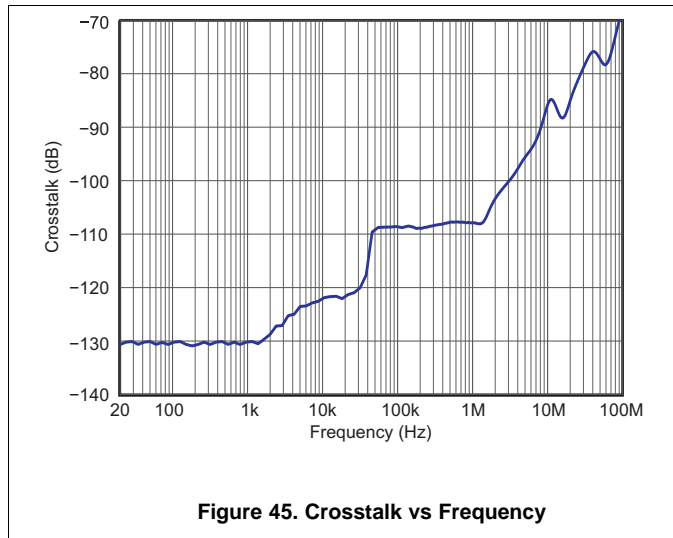


Figure 45. Crosstalk vs Frequency

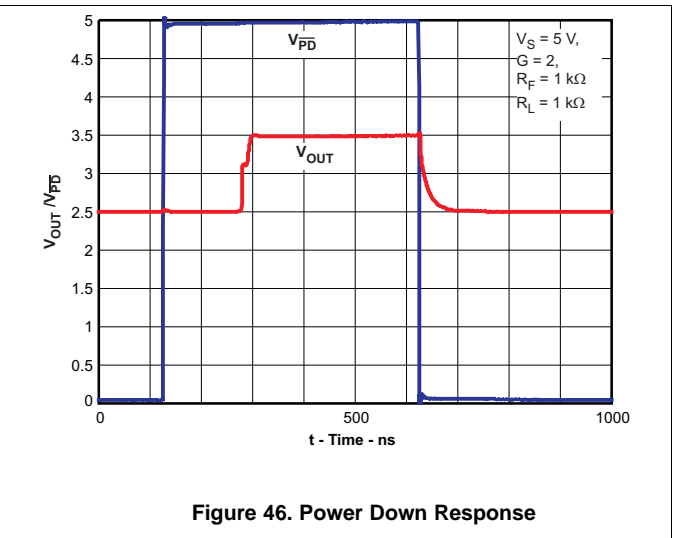


Figure 46. Power Down Response

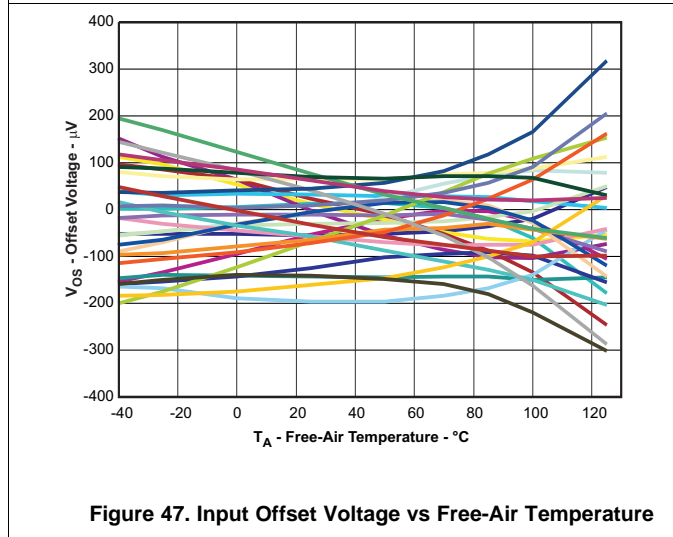


Figure 47. Input Offset Voltage vs Free-Air Temperature

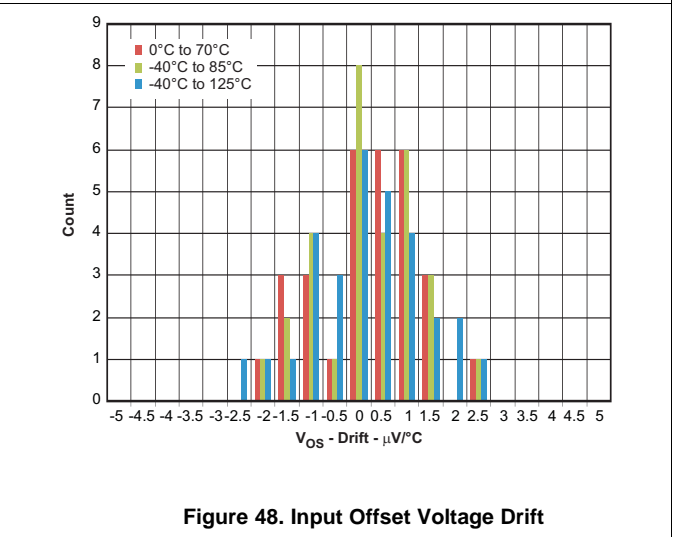


Figure 48. Input Offset Voltage Drift

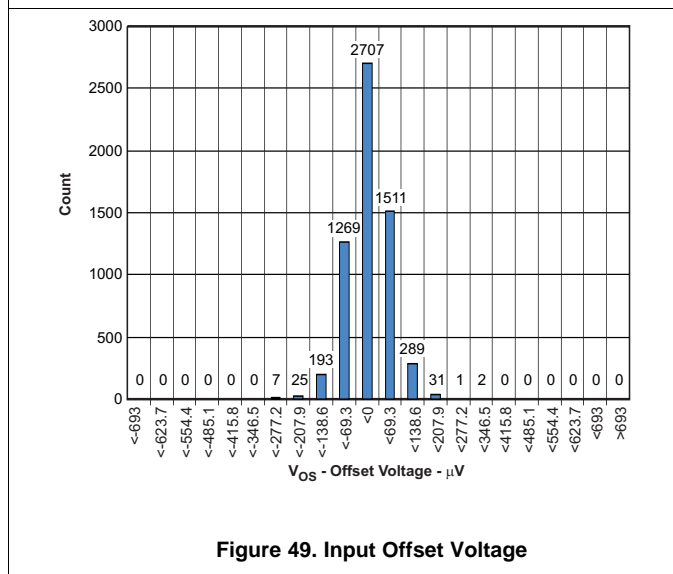


Figure 49. Input Offset Voltage

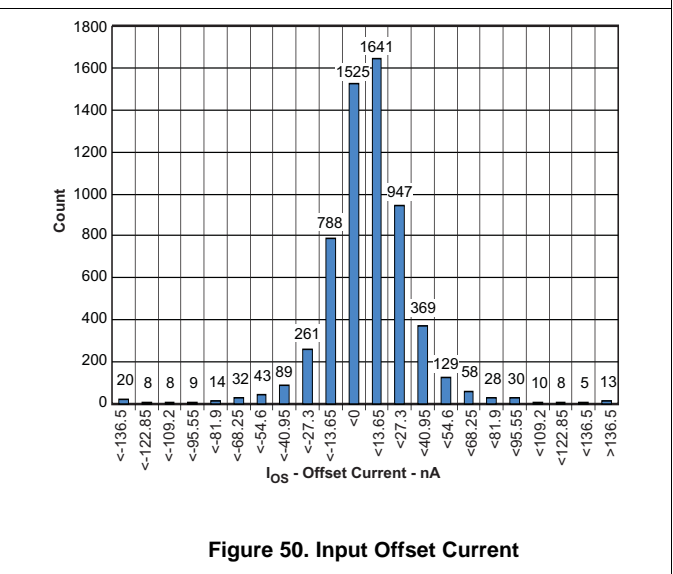
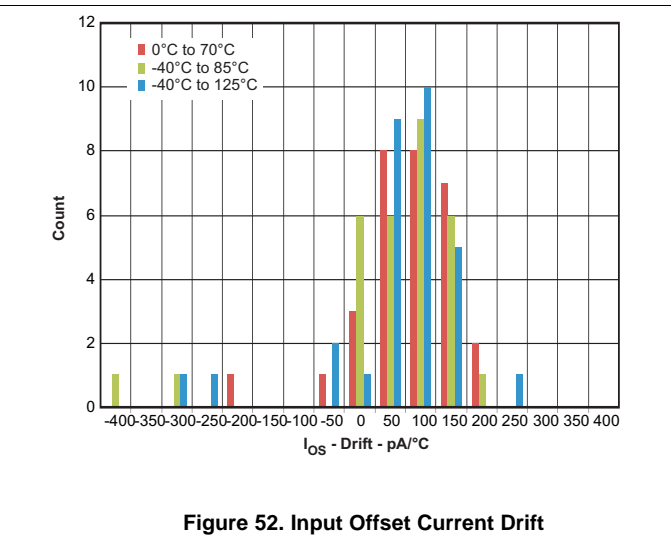
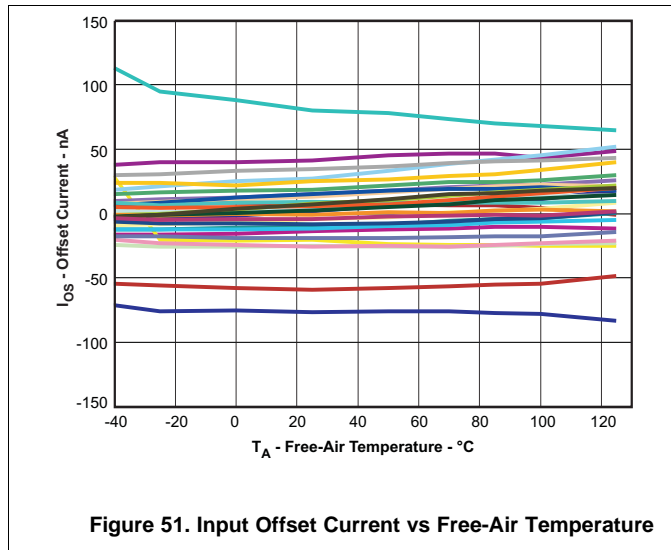


Figure 50. Input Offset Current

at  $V_{S+} = +5\text{ V}$ ,  $V_{S-} = 0\text{ V}$ ,  $V_{OUT} = 2\text{ V}_{PP}$ ,  $R_F = 0\ \Omega$ ,  $R_L = 1\text{ k}\Omega$ ,  $G = 1\text{ V/V}$ , input and output referenced to mid-supply unless otherwise noted.  $T_A = 25^\circ\text{C}$ , unless otherwise noted.



## 8 Detailed Description

### 8.1 Overview

The OPAx836 family of bipolar-input operational amplifiers offers excellent bandwidth of 205 MHz with ultra-low THD of 0.00003% at 1 kHz. The OPAx836 device can swing to within 200 mV of the supply rails while driving a 1-k $\Omega$  load. The input common-mode of the amplifier can swing to 200 mV below the negative supply rail. This level of performance is achieved at 1 mA of quiescent current per amplifier channel.

### 8.2 Functional Block Diagrams

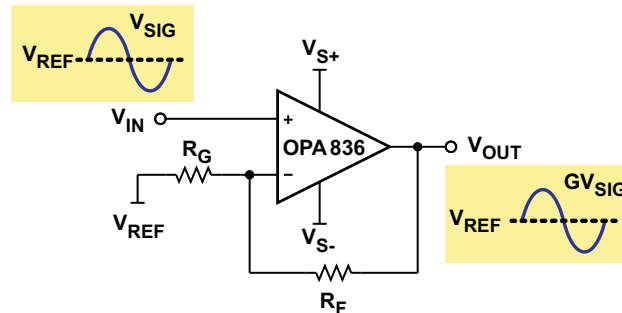


Figure 53. Noninverting Amplifier

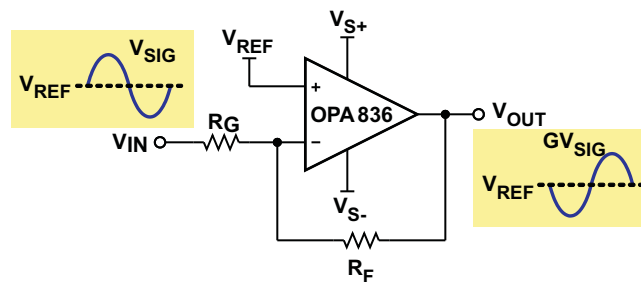


Figure 54. Inverting Amplifier

### 8.3 Feature Description

#### 8.3.1 Input Common-Mode Voltage Range

When the primary design goal is a linear amplifier with high CMRR, it is important to not violate the input common-mode voltage range ( $V_{ICR}$ ) of an operational amplifier.

The common-mode input range specifications in the table data use CMRR to set the limit. The limits are selected to ensure CMRR will not degrade more than 3 dB below the CMRR limit if the input voltage is kept within the specified range. The limits cover all process variations and most parts will be better than specified. The typical specifications are from 0.2 V below the negative rail to 1.1 V below the positive rail.

Assuming the operational amplifier is in linear operation, the voltage difference between the input pins is small (ideally 0 V) and input common-mode voltage is analyzed at either input pin with the other input pin assumed to be at the same potential. The voltage at  $V_{IN+}$  is simple to evaluate. In noninverting configuration, [Figure 53](#), the input signal,  $V_{IN+}$ , must not violate the  $V_{ICR}$ . In inverting configuration, [Figure 54](#), the reference voltage,  $V_{REF}$ , must be within the  $V_{ICR}$ .

The input voltage limits have fixed headroom to the power rails and track the power supply voltages. For one 5-V supply, the linear input voltage ranges from  $-0.2$  V to 3.9 V and from  $-0.2$  V to 1.6 V for a 2.7-V supply. The delta headroom from each power supply rail is the same in either case:  $-0.2$  V and 1.1 V.

## Feature Description (continued)

### 8.3.2 Output Voltage Range

The OPA836 and OPA2836 devices are rail-to-rail output (RRO) operational amplifiers. Rail-to-rail output typically means the output voltage swings within a couple hundred millivolts of the supply rails. There are different ways to specify this: one is with the output still in linear operation and another is with the output saturated. Saturated output voltages are closer to the power supply rails than linear outputs, but the signal is not a linear representation of the input. Linear output is a better representation of how well a device performs when used as a linear amplifier. Saturation and linear operation limits are affected by the output current, where higher currents lead to more loss in the output transistors.

Figure 11 and Figure 37 show saturated voltage-swing limits versus output load resistance and Figure 12 and Figure 38 show the output saturation voltage versus load current. Given a light load, the output voltage limits have nearly constant headroom to the power rails and track the power supply voltages. For example, with a 2-k $\Omega$  load and single 5-V supply, the linear output voltage ranges from 0.15 V to 4.8 V, and ranges from 0.15 V to 2.5 V for a 2.7-V supply. The delta from each power supply rail is the same in either case: 0.15 V and 0.2 V.

With devices like the OPA836 and OPA2836, where the input range is lower than the output range, typically the input will limit the available signal swing only in noninverting gain of 1. Signal swing in noninverting configurations in gains  $> +1$  and inverting configurations in any gain is typically limited by the output voltage limits of the operational amplifier.

### 8.3.3 Power-Down Operation

The OPA836 and OPA2836 devices include a power-down mode. Under logic control, the amplifiers can switch from normal operation to a standby current of  $< 1.5 \mu\text{A}$ . When the PD pin is connected high, the amplifier is active. Connecting PD pin low disables the amplifier and places the output in a high-impedance state. When the amplifier is configured as a unity-gain buffer, the output stage is in a high dc-impedance state. To protect the input stage of the amplifier, the devices use internal, back-to-back ESD diodes between the inverting and noninverting input pins. This configuration creates a parallel low-impedance path from the amplifier output to the noninverting pin when the differential voltage between the pins exceeds a diode voltage drop. When the op amp is configured in other gains, the feedback (RF) and gain (RG) resistor network forms a parallel load.

The  $\overline{\text{PD}}$  pin must be actively driven high or low and must not be left floating. If the power-down mode is not used,  $\overline{\text{PD}}$  must be tied to the positive supply rail.

$\overline{\text{PD}}$  logic states are TTL with reference to the negative supply rail and  $V_{\text{S-}}$ . When the operational amplifier is powered from single-supply and ground and driven from logic devices with similar  $V_{\text{DD}}$ , voltages to the operational amplifier do not require any special consideration. When the operational amplifier is powered from a split supply, with  $V_{\text{S-}}$  below ground, an open-collector type of interface with pullup resistor is more appropriate. Pullup resistor values must be lower than 100 k $\Omega$ . Additionally, the drive logic must be negated due to the inverting action of an open-collector gate.

### 8.3.4 Low-Power Applications and the Effects of Resistor Values on Bandwidth

The OPA836 and OPA2836 devices are designed for the nominal value of  $R_{\text{F}}$  to be 1 k $\Omega$  in gains other than +1. This gives excellent distortion performance, maximum bandwidth, best flatness, and best pulse response, but it also loads the amplifier. For example; in gain of 2 with  $R_{\text{F}} = R_{\text{G}} = 1 \text{ k}\Omega$ ,  $R_{\text{G}}$  to ground, and  $V_{\text{OUT}} = 4 \text{ V}$ , 2 mA of current will flow through the feedback path to ground. In gain of +1,  $R_{\text{G}}$  is open and no current will flow to ground. In low-power applications, it is desirable to reduce the current in the feedback by increasing the gain-setting resistors values. Using larger value gain resistors has two primary side effects (other than lower power) due to their interaction with parasitic circuit capacitance:

- Lowers the bandwidth
- Lowers the phase margin
  - This causes peaking in the frequency response
  - This also causes overshoot and ringing in the pulse response

Figure 55 shows the small-signal frequency response on OPA836EVM for noninverting gain of 2 with  $R_{\text{F}}$  and  $R_{\text{G}}$  equal to 1 k $\Omega$ , 10 k $\Omega$ , and 100 k $\Omega$ . The test was done with  $R_{\text{L}} = 1 \text{ k}\Omega$ . Due to loading effects of  $R_{\text{L}}$ , lower  $R_{\text{L}}$  values may reduce the peaking, but higher values will not have a significant effect.

Feature Description (continued)

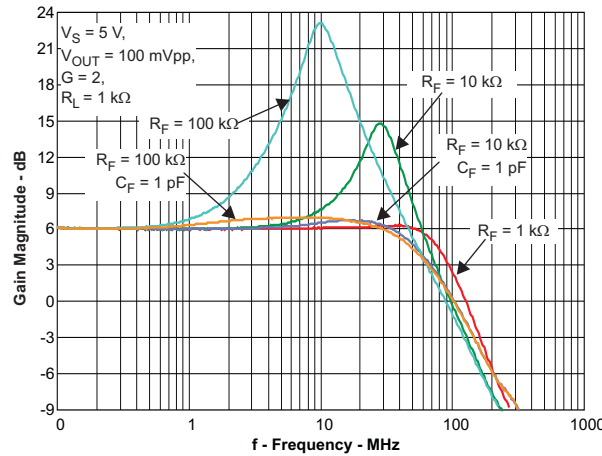


Figure 55. Frequency Response With Various Gain-Setting Resistor Values

As expected, larger value gain resistors cause lower bandwidth and peaking in the response (peaking in the frequency response is synonymous with overshoot and ringing in the pulse response). Adding 1-pF capacitors in parallel with  $R_F$  helps compensate the phase margin and restores flat frequency response. Figure 56 shows the test circuit.

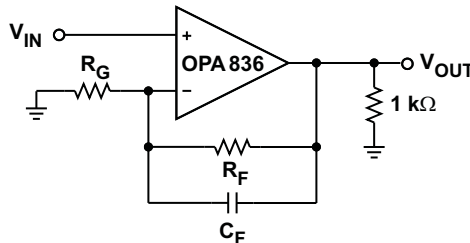


Figure 56.  $G = 2$  Test Circuit for Various Gain-Setting Resistor Values

8.3.5 Driving Capacitive Loads

The OPA836 and OPA2836 devices can drive up to a nominal capacitive load of 2.2 pF on the output with no special consideration. When driving capacitive loads greater than 2.2 pF, TI recommends using a small resistor ( $R_O$ ) in series with the output as close to the device as possible. Without  $R_O$ , capacitance on the output interacts with the output impedance of the amplifier causing phase shift in the loop gain of the amplifier that will reduce the phase margin. This will cause peaking in the frequency response and overshoot and ringing in the pulse response. Interaction with other parasitic elements may lead to instability or oscillation. Inserting  $R_O$  will isolate the phase shift from the feedback path and restore the phase margin; however,  $R_O$  can limit the bandwidth slightly.

Figure 57 shows the test circuit and Figure 43 shows the recommended values of  $R_O$  versus capacitive loads,  $C_L$ . See Figure 40 for the frequency response with various values.

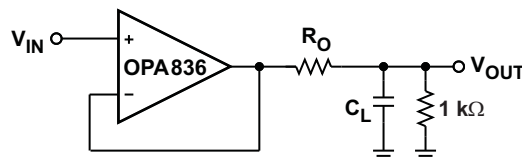


Figure 57.  $R_O$  versus  $C_L$  Test Circuit

## 8.4 Device Functional Modes

### 8.4.1 Split-Supply Operation ( $\pm 1.25\text{ V}$ to $\pm 2.75\text{ V}$ )

To facilitate testing with common lab equipment, the OPA836 EVM (see [OPA835DBV](#), [OPA836DBV EVM](#), SLOU314) is built to allow for split-supply operation. This configuration eases lab testing because the mid-point between the power rails is ground, and most signal generators, network analyzers, oscilloscopes, spectrum analyzers and other lab equipment have inputs and outputs with a ground reference.

Figure 58 shows a simple noninverting configuration analogous to Figure 53 with  $\pm 2.5\text{-V}$  supply and  $V_{REF}$  equal to ground. The input and output will swing symmetrically around ground. For ease of use, split supplies are preferred in systems where signals swing around ground.

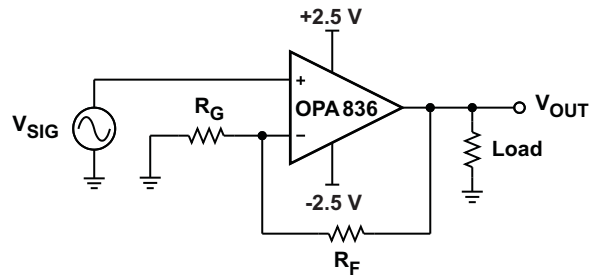


Figure 58. Split-Supply Operation

### 8.4.2 Single-Supply Operation (2.5 V to 5.5 V)

Often, newer systems use a single power supply to improve efficiency and reduce the cost of the power supply. The OPA836 and OPA2836 devices are designed for use with a single supply with no change in performance compared to a split supply, as long as the input and output are biased within the linear operation of the device.

To change the circuit from split supply to single supply, level shift of all voltages by half the difference between the power supply rails. For example, changing from  $\pm 2.5\text{-V}$  split supply to  $5\text{-V}$  single supply is shown in Figure 59.

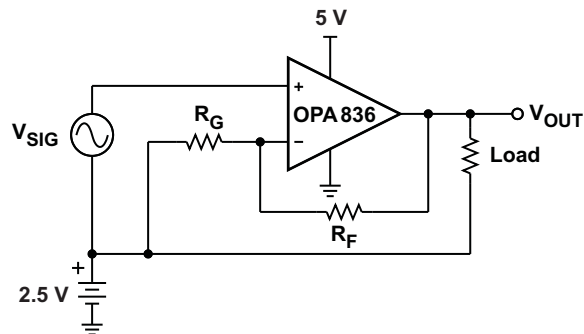


Figure 59. Single-Supply Concept

A practical circuit will have an amplifier or other circuit providing the bias voltage for the input, and the output of this amplifier stage provides the bias for the next stage.

Figure 60 shows a typical noninverting amplifier circuit. With  $5\text{-V}$  single-supply, a mid-supply reference generator is needed to bias the negative side through  $R_G$ . To cancel the voltage offset that would otherwise be caused by the input bias currents,  $R_1$  is selected to be equal to  $R_F$  in parallel with  $R_G$ . For example, if gain of 2 is required and  $R_F = 1\text{ k}\Omega$ , select  $R_G = 1\text{ k}\Omega$  to set the gain and  $R_1 = 499\ \Omega$  for bias-current cancellation. The value for  $C$  depends on the reference; TI recommends a value of at least  $0.1\ \mu\text{F}$  to limit noise.

Device Functional Modes (continued)

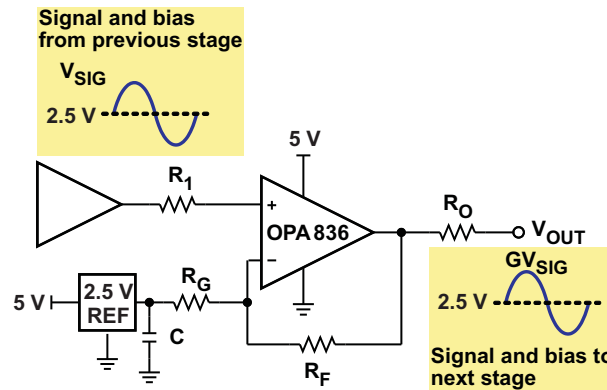


Figure 60. Noninverting Single Supply With Reference

Figure 61 shows a similar noninverting single-supply scenario with the reference generator replaced by the Thevenin equivalent using resistors and the positive supply.  $R_G'$  and  $R_G''$  form a resistor divider from the 5-V supply and are used to bias the negative side with their parallel sum equal to the equivalent  $R_G$  to set the gain. To cancel the voltage offset that would otherwise be caused by the input bias currents,  $R_1$  is selected to be equal to  $R_F$  in parallel with  $R_G'$  in parallel with  $R_G''$  ( $R_1 = R_F \parallel R_G' \parallel R_G''$ ). For example, if gain of 2 is required and  $R_F = 1 \text{ k}\Omega$ , selecting  $R_G' = R_G'' = 2 \text{ k}\Omega$  gives equivalent parallel sum of  $1 \text{ k}\Omega$ , sets the gain to 2, and references the input to mid supply (2.5 V).  $R_1$  is then set to  $499 \Omega$  for bias-current cancellation. The resistor divider costs less than the 2.5 V reference in Figure 60 but may increase the current from the 5-V supply.

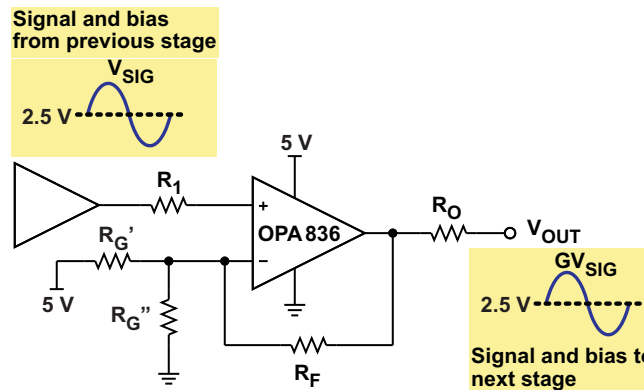


Figure 61. Noninverting Single Supply With Resistors

Figure 62 shows a typical inverting amplifier situation. With 5-V single supply, a mid-supply reference generator is needed to bias the positive side through  $R_1$ . To cancel the voltage offset that would otherwise be caused by the input bias currents,  $R_1$  is selected to be equal to  $R_F$  in parallel with  $R_G$ . For example if gain of  $-2$  is required and  $R_F = 1 \text{ k}\Omega$ , select  $R_G = 499 \Omega$  to set the gain and  $R_1 = 332 \Omega$  for bias-current cancellation. The value for C is dependent on the reference, but TI recommends a value of at least  $0.1 \mu\text{F}$  to limit noise into the operational amplifier.

Device Functional Modes (continued)

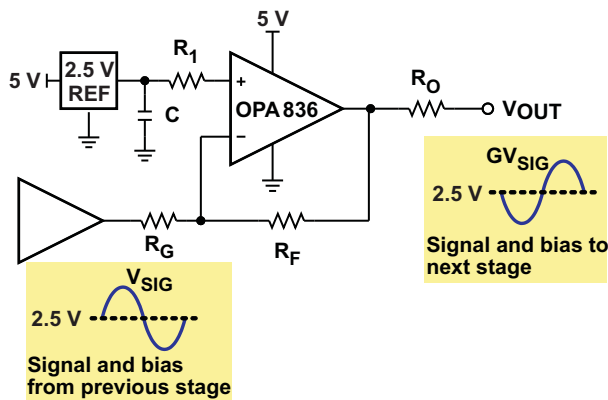


Figure 62. Inverting Single Supply With Reference

Figure 63 shows a similar inverting single-supply scenario with the reference generator replaced by the Thevenin equivalent using resistors and the positive supply.  $R_1$  and  $R_2$  form a resistor divider from the 5-V supply and are used to bias the positive side. To cancel the voltage offset that would otherwise be caused by the input bias currents, set the parallel sum of  $R_1$  and  $R_2$  equal to the parallel sum of  $R_F$  and  $R_G$ .  $C$  must be added to limit coupling of noise into the positive input. For example if gain of  $-2$  is required and  $R_F = 1\text{ k}\Omega$ , select  $R_G = 499\ \Omega$  to set the gain.  $R_1 = R_2 = 665\ \Omega$  for mid-supply voltage bias and for operational amplifier input bias-current cancellation. A good value for  $C$  is  $0.1\ \mu\text{F}$ . The resistor divider costs less than the 2.5-V reference in Figure 62 but may increase the current from the 5-V supply.

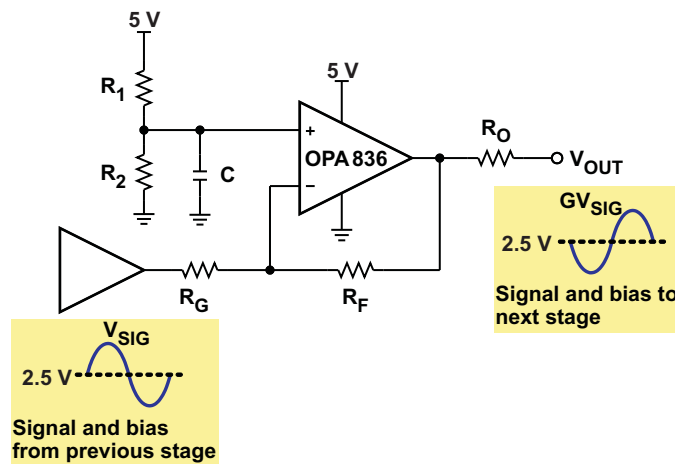


Figure 63. Inverting Single Supply With Resistors

## 9 Application and Implementation

### NOTE

Information in the following applications sections is not part of the TI component specification, and TI does not warrant its accuracy or completeness. TI's customers are responsible for determining suitability of components for their purposes. Customers should validate and test their design implementation to confirm system functionality.

### 9.1 Application Information

#### 9.1.1 Noninverting Amplifier

The OPA836 and OPA2836 devices can be used as noninverting amplifiers with signal input to the noninverting input,  $V_{IN+}$ . A basic block diagram of the circuit is shown in [Figure 53](#).

If  $V_{IN} = V_{REF} + V_{SIG}$ , then the output of the amplifier may be calculated according to [Equation 1](#).

$$V_{OUT} = V_{SIG} \left( 1 + \frac{R_F}{R_G} \right) + V_{REF} \quad (1)$$

$$G = 1 + \frac{R_F}{R_G}$$

The signal gain of the circuit is set by  $\frac{R_F}{R_G}$ , and  $V_{REF}$  provides a reference around which the input and output signals swing. Output signals are in-phase with the input signals.

The OPA836 and OPA2836 devices are designed for the nominal value of  $R_F$  to be 1 k $\Omega$  in gains other than +1. This gives excellent distortion performance, maximum bandwidth, best flatness, and best pulse response.  $R_F = 1$  k $\Omega$  must be used as a default unless other design goals require changing to other values. All test circuits used to collect data for this data sheet had  $R_F = 1$  k $\Omega$  for all gains other than +1. Gain of +1 is a special case where  $R_F$  is shorted and  $R_G$  is left open.

#### 9.1.2 Inverting Amplifier

The OPA836 and OPA2836 devices can be used as inverting amplifiers with signal input to the inverting input,  $V_{IN-}$ , through the gain setting resistor  $R_G$ . A basic block diagram of the circuit is shown in [Figure 54](#).

If  $V_{IN} = V_{REF} + V_{SIG}$ , then the output of the amplifier may be calculated according to [Equation 2](#).

$$V_{OUT} = V_{SIG} \left( \frac{-R_F}{R_G} \right) + V_{REF} \quad (2)$$

$$G = \frac{-R_F}{R_G}$$

The signal gain of the circuit is set by  $\frac{-R_F}{R_G}$ , and  $V_{REF}$  provides a reference point around which the input and output signals swing. Output signals are 180° out-of-phase with the input signals. The nominal value of  $R_F$  must be 1 k $\Omega$  for inverting gains.

#### 9.1.3 Instrumentation Amplifier

[Figure 64](#) is an instrumentation amplifier that combines the high input impedance of the differential-to-differential amplifier circuit and the common-mode rejection of the differential-to-single-ended amplifier circuit. This circuit is often used in applications where high input impedance is required (such as taps from a differential line) or in cases where the signal source has a high output impedance.

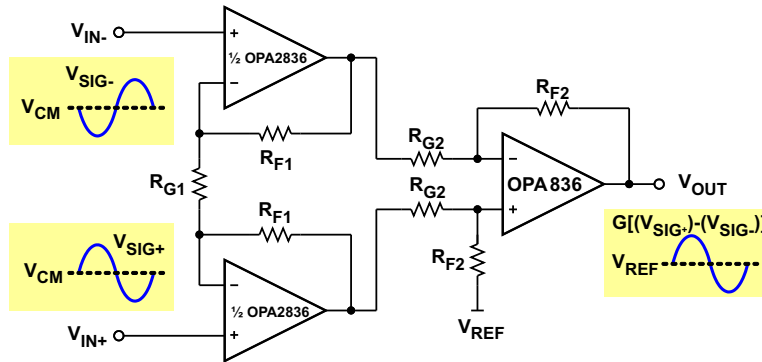
If  $V_{IN+} = V_{CM} + V_{SIG+}$  and  $V_{IN-} = V_{CM} + V_{SIG-}$ , then the output of the amplifier may be calculated according to [Equation 3](#).

$$V_{OUT} = (V_{IN+} - V_{IN-}) \times \left( 1 + \frac{2R_{F1}}{R_{G1}} \right) \left( \frac{R_{F2}}{R_{G2}} \right) + V_{REF} \quad (3)$$

**Application Information (continued)**

$$G = \left( 1 + \frac{2R_{F1}}{R_{G1}} \right) \left( \frac{R_{F2}}{R_{G2}} \right)$$

The signal gain of the circuit is set by  $V_{CM}$  is rejected, and  $V_{REF}$  provides a level shift around which the output signal swings. The single-ended output signal is in-phase with the differential input signal.



**Figure 64. Instrumentation Amplifier**

Integrated solutions are available, but the OPA836 device provides a much lower-power, high-frequency solution. For best CMRR performance, resistors must be matched. A good guideline to follow is  $CMRR \approx$  the resistor tolerance; so, 0.1% tolerance will provide approximately 60-dB CMRR.

**9.1.4 Attenuators**

The noninverting circuit of Figure 53 has minimum gain of 1. To implement attenuation, a resistor divider can be placed in series with the positive input, and the amplifier set for gain of 1 by shorting  $V_{OUT}$  to  $V_{IN-}$  and removing  $R_G$ . Because the operational amplifier input is high impedance, the resistor divider sets the attenuation.

The inverting circuit of Figure 54 can be used as an attenuator by making  $R_G$  larger than  $R_F$ . The attenuation is the resistor ratio. For example, a 10:1 attenuator can be implemented with  $R_F = 1\text{ k}\Omega$  and  $R_G = 10\text{ k}\Omega$ .

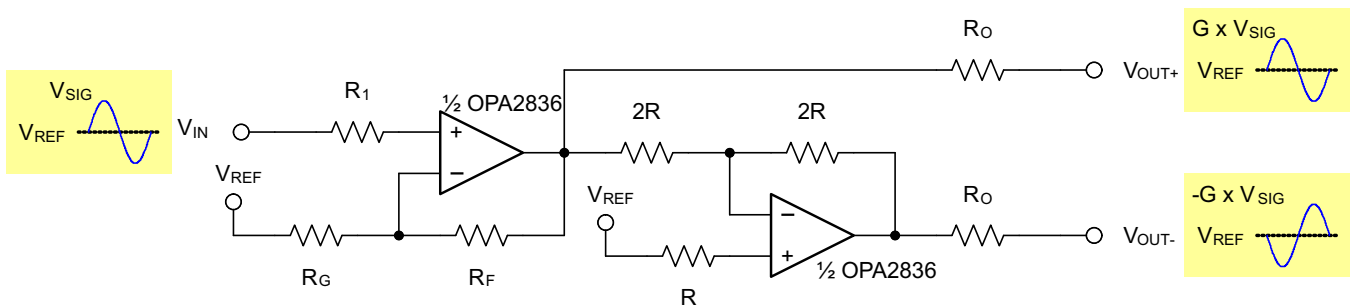
**9.1.5 Single-Ended-to-Differential Amplifier**

Figure 65 shows an amplifier circuit that is used to convert single-ended signals to differential, and provides gain and level shifting. This circuit can be used for converting signals to differential in applications like line drivers for Cat5 cabling or driving differential-input SAR and  $\Delta\Sigma$  ADCs.

With  $V_{IN} = V_{REF} + V_{SIG}$ , the output of the amplifier may be calculated according to Equation 4.

$$V_{OUT+} = G \times V_{IN} + V_{REF} \quad \text{and} \quad V_{OUT-} = -G \times V_{IN} + V_{REF} \quad \text{Where: } G = 1 + \frac{R_F}{R_G} \tag{4}$$

The differential-signal gain of the circuit is  $2 \times G$ , and  $V_{REF}$  provides a reference around which the output signal swings. The differential output signal is in-phase with the single-ended input signal.



**Figure 65. Single Ended to Differential Amplifier**

## Application Information (continued)

Line termination on the output can be accomplished with resistors  $R_O$ . The differential impedance seen from the line will be  $2 \times R_O$ . For example, if 100- $\Omega$  Cat5 cable is used with double termination, the amplifier is typically set for a differential gain of 2 V/V (6 dB) with  $R_F = 0 \Omega$  (short),  $R_G = \text{open}$ ,  $2R = 1 \text{ k}\Omega$ ,  $R_1 = 0 \Omega$ ,  $R = 499 \Omega$  to balance the input bias currents, and  $R_O = 49.9 \Omega$  for output line termination. This configuration is shown in Figure 66.

For driving a differential-input ADC the situation is similar, but the output resistors,  $R_O$  are selected with a capacitor across the ADC input for optimum filtering and settling-time performance.

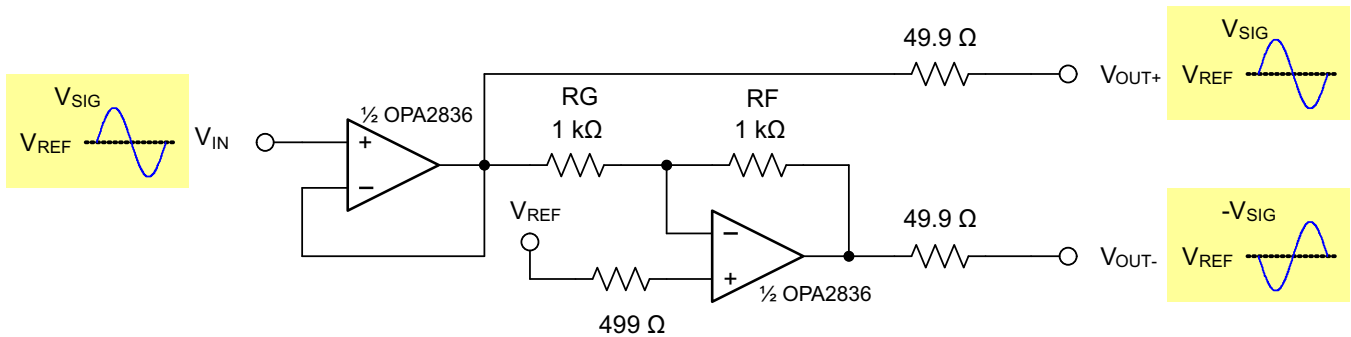


Figure 66. Cat5 Line Driver With Gain = 2 V/V (6 dB)

### 9.1.6 Differential-to-Signal-Ended Amplifier

Figure 67 shows a differential amplifier that is used to convert differential signals to single-ended and provides gain (or attenuation) and level shifting. This circuit can be used in applications like a line receiver for converting a differential signal from a Cat5 cable to a single-ended signal.

If  $V_{IN+} = V_{CM} + V_{SIG+}$  and  $V_{IN-} = V_{CM} + V_{SIG-}$ , then the output of the amplifier may be calculated according to Equation 5.

$$V_{OUT} = (V_{IN+} - V_{IN-}) \times \left( \frac{R_F}{R_G} \right) + V_{REF} \quad (5)$$

The signal gain of the circuit is  $G = \frac{R_F}{R_G}$ ,  $V_{CM}$  is rejected, and  $V_{REF}$  provides a level shift around which the output signal swings. The single ended output signal is in-phase with the differential input signal.

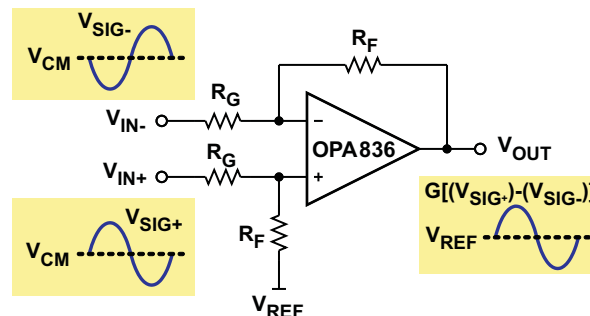


Figure 67. Differential to Single-Ended Amplifier

Line termination can be accomplished by adding a shunt resistor across the  $V_{IN+}$  and  $V_{IN-}$  inputs. The differential impedance is the shunt resistance in parallel with the input impedance of the amplifier circuit, which is usually much higher. For low gain and low line impedance, the resistor value to add is approximately the impedance of the line. For example if 100- $\Omega$  Cat5 cable is used with a gain of 1 amplifier and  $R_F = R_G = 1 \text{ k}\Omega$ , adding a 100- $\Omega$  shunt across the input will give a differential impedance of 98  $\Omega$ , which is adequate for most applications.

## Application Information (continued)

For best CMRR performance, resistors must be matched. Assuming  $CMRR \approx$  the resistor tolerance, a 0.1% tolerance will provide about 60-dB CMRR.

### 9.1.7 Differential-to-Differential Amplifier

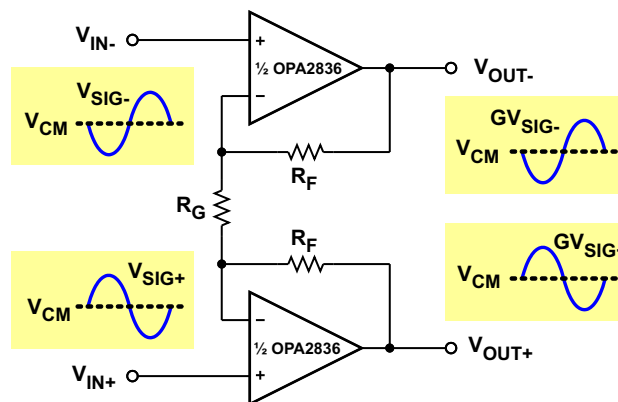
Figure 68 shows a differential amplifier that is used to amplify differential signals. This circuit has high input impedance and is used in differential line driver applications where the signal source is a high-impedance driver (for example, a differential DAC) that must drive a line.

If  $V_{IN\pm} = V_{CM} + V_{SIG\pm}$ , then the output of the amplifier may be calculated according to Equation 6.

$$V_{OUT\pm} = V_{IN\pm} \times \left( 1 + \frac{2R_F}{R_G} \right) + V_{CM} \quad (6)$$

$$G = 1 + \frac{2R_F}{R_G}$$

The signal gain of the circuit is set by  $\frac{2R_F}{R_G}$ , and  $V_{CM}$  passes with unity gain. The amplifier in essence combines two noninverting amplifiers into one differential amplifier that shares the  $R_G$  resistor, which makes  $R_G$  effectively half its value when calculating the gain. The output signals are in-phase with the input signals.



**Figure 68. Differential to Differential Amplifier**

### 9.1.8 Gain Setting With OPA836 RUN Integrated Resistors

The OPA836 RUN package option includes integrated gain-setting resistors for smallest possible footprint on a printed circuit board ( $\approx 2.00 \text{ mm} \times 2.00 \text{ mm}$ ). By adding circuit traces on the PCB, gains of +1, -1, -1.33, +2, +2.33, -3, +4, -4, +5, -5.33, +6.33, -7, +8 and inverting attenuations of -0.1429, -0.1875, -0.25, -0.33, -0.75 can be achieved.

Figure 69 shows a simplified view of how the OPA836IRUN integrated gain-setting network is implemented. Table 3 lists the required pin connections for various noninverting and inverting gains (reference Figure 53 and Figure 54). Table 4 shows the required pin connections for various attenuations using the inverting-amplifier architecture (reference Figure 54). Due to ESD protection devices being used on all pins, the absolute maximum and minimum input-voltage range,  $V_{S-} - 0.7 \text{ V}$  to  $V_{S+} + 0.7 \text{ V}$ , applies to the gain-setting resistors, so attenuation of large input voltages requires external resistors to implement.

The gain-setting resistors are laser trimmed to 1% tolerance with nominal values of 1.6 k $\Omega$ , 1.2 k $\Omega$ , and 400  $\Omega$ . The gain-setting resistors have excellent temperature coefficients, and gain drift is superior to the drift with external gain-setting resistors. The 500- $\Omega$  and 1.5-pF capacitor in parallel with the 1.6-k $\Omega$  gain-setting resistor provide compensation for best stability and pulse response.

Application Information (continued)

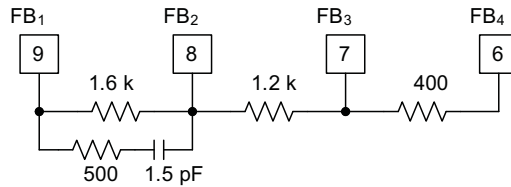


Figure 69. OPA836IRUN Gain-Setting Network

Table 3. Gain Settings

NONINVERTING GAIN (Figure 53)	INVERTING GAIN (Figure 54)	SHORT PINS	SHORT PINS	SHORT PINS	SHORT PINS
1 V/V (0 dB)	—	1 to 9			—
2 V/V (6.02 dB)	–1 V/V (0 dB)	1 to 9	2 to 8	6 to GND	—
2.33 V/V (7.36 dB)	–1.33 V/V (2.5 dB)	1 to 9	2 to 8	7 to GND	—
4 V/V (12.04 dB)	–3 V/V (9.54 dB)	1 to 8	2 to 7	6 to GND	—
5 V/V (13.98 dB)	–4 V/V (12.04 dB)	1 to 9	2 to 7 or 8	7 to 8	6 to GND
6.33 V/V (16.03 dB)	–5.33 V/V (14.54 dB)	1 to 9	2 to 6 or 8	6 to 8	7 to GND
8 V/V (18.06 dB)	–7 V/V (16.90 dB)	1 to 9	2 to 7	6 to GND	—

Table 4. Attenuator Settings

INVERTING GAIN (Figure 54)	SHORT PINS	SHORT PINS	SHORT PINS	SHORT PINS
–0.75 V/V (–2.5 dB)	1 to 7	2 to 8	9 to GND	—
–0.333 V/V (–9.54 dB)	1 to 6	2 to 7	8 to GND	—
–0.25 V/V (–12.04 dB)	1 to 6	2 to 7 or 8	7 to 8	9 to GND
–0.1875 V/V (–14.54 dB)	1 to 7	2 to 6 or 8	6 to 8	9 to GND
–0.1429 V/V (–16.90 dB)	1 to 6	2 to 7	9 to GND	—

9.1.9 Pulse Application With Single-Supply

For pulsed applications, where the signal is at ground and pulses to a positive or negative voltage, the circuit bias-voltage considerations differ from those in an application with a signal that swings symmetrical about a reference point. Figure 70 shows a circuit where the signal is at ground (0 V) and pulses to a positive value.

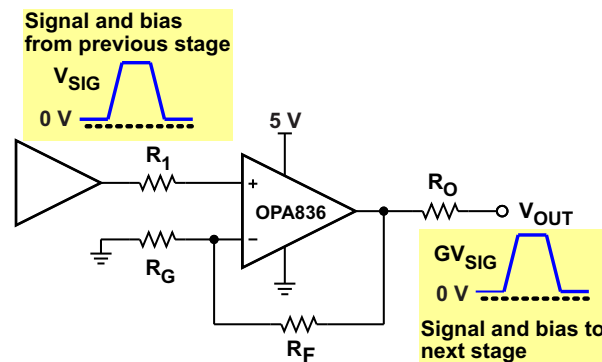
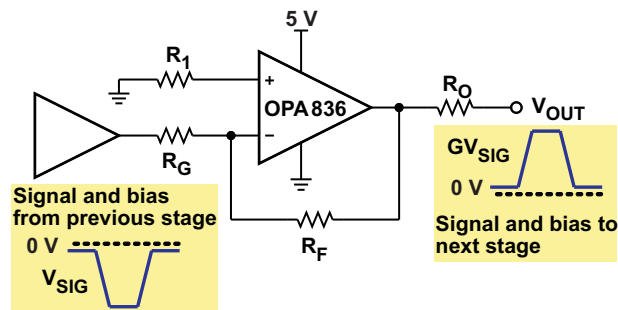


Figure 70. Noninverting Single Supply With Pulse

If the input signal pulses negative from ground, an inverting amplifier is more appropriate as shown in [Figure 71](#). A key consideration in noninverting and inverting cases is that the input and output voltages are kept within the limits of the amplifier. Because the  $V_{ICR}$  of the OPA836 device includes the negative supply rail, the OPA836 operational amplifier is well-suited to this application.



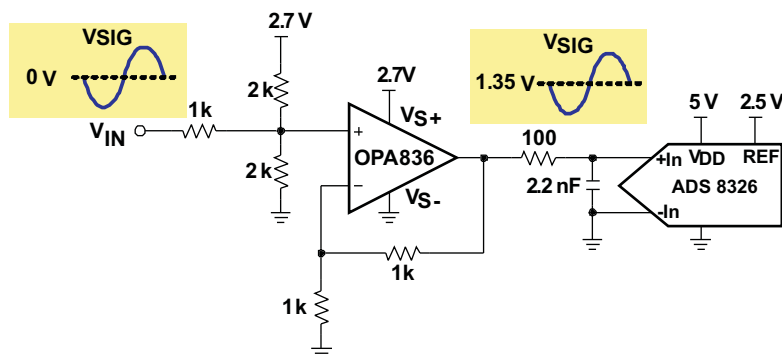
**Figure 71. Inverting Single Supply With Pulse**

### 9.1.10 ADC Driver Performance

The OPA836 device provides excellent performance when driving high-performance delta-sigma ( $\Delta\Sigma$ ) and successive-approximation-register (SAR) ADCs in low-power audio and industrial applications.

To show achievable performance, the OPA836 device is tested as the drive amplifier for the ADS8326. The ADS8326 is a 16-bit, micro power, SAR ADC with pseudodifferential inputs and sample rates up to 250 kSPS. The device offers excellent noise and distortion performance in a small 8-pin SOIC or VSSOP (MSOP) package. Low power and small size make the ADS8326 and OPA836 devices an ideal solution for portable and battery-operated systems, remote data-acquisition modules, simultaneous multichannel systems, and isolated data acquisition.

With the circuit shown in [Figure 72](#) to test the performance, [Figure 73](#) shows the FFT plot with a 10-kHz input signal. The tabulated AC analysis is in [Table 5](#).



**Figure 72. OPA836 and ADS8326 Test Circuit**

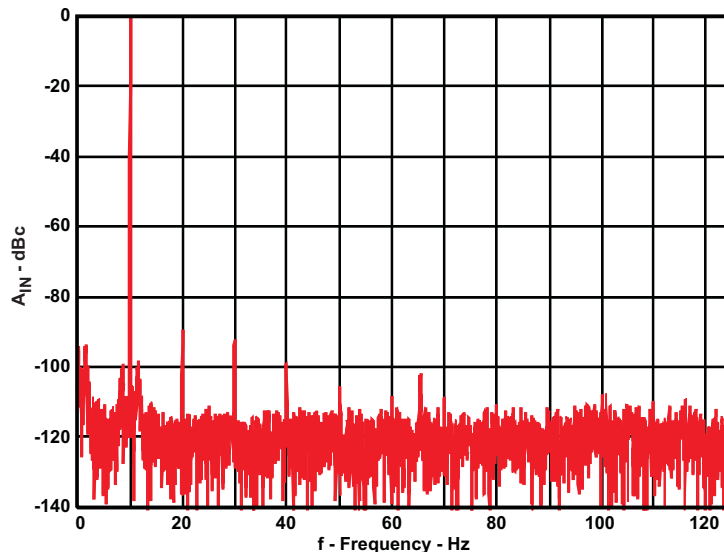


Figure 73. ADS8326 and OPA836 10-kHz FFT

Table 5. AC Analysis

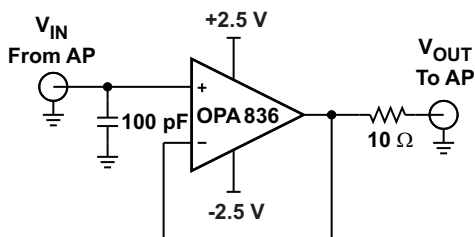
TONE (Hz)	SIGNAL (dBFS)	SNR (dBc)	THD (dBc)	SINAD (dBc)	SFDR (dBc)
10k	-0.85	83.3	-86.6	81.65	88.9

## 9.2 Typical Applications

### 9.2.1 Audio Frequency Performance

The OPA836 and OPA2836 devices provide excellent audio performance with low quiescent power. To show performance in the audio band, an audio analyzer from Audio Precision (2700 series) tests THD+N and FFT at 1  $V_{RMS}$  output voltage.

Figure 74 shows the circuit used for the audio-frequency performance test.



The 100-pF capacitor to ground on the input helped to decouple noise pick up in the lab and improved noise performance.

Figure 74. OPA836 Audio Precision Analyzer Test Circuit

## Typical Applications (continued)

### 9.2.1.1 Design Requirements

Design a low distortion, single-ended input to single-ended output audio amplifier using the OPA836 device. The 2700-series audio analyzer from Audio Precision is used as the signal source and also as the measurement system.

**Table 6. Design Requirements**

CONFIGURATION	INPUT EXCITATION	PERFORMANCE TARGET	R <sub>Load</sub>
OPA836 Unity Gain Config.	1 KHz Tone Frequency	>110 dBc SFDR	300 Ω and 100 kΩ

### 9.2.1.2 Detailed Design Procedure

The OPA836 device is tested in this application in a unity-gain buffer configuration. A buffer configuration is selected for maximum loop gain of the amplifier circuit. At higher closed-loop gains, the loop gain of the circuit reduces, which increases the harmonic distortion. The relationship between distortion and closed-loop gain at a fixed input frequency is shown in [Figure 36](#) in [Typical Performance Graphs: V<sub>S</sub> = 5 V](#). The test was performed under using resistive loads of 300 Ω and 100 kΩ. [Figure 34](#) shows the distortion performance of the amplifier versus the resistive load. Output loading, output swing, and closed-loop gain play a key role in determining the distortion performance of the amplifier.

#### NOTE

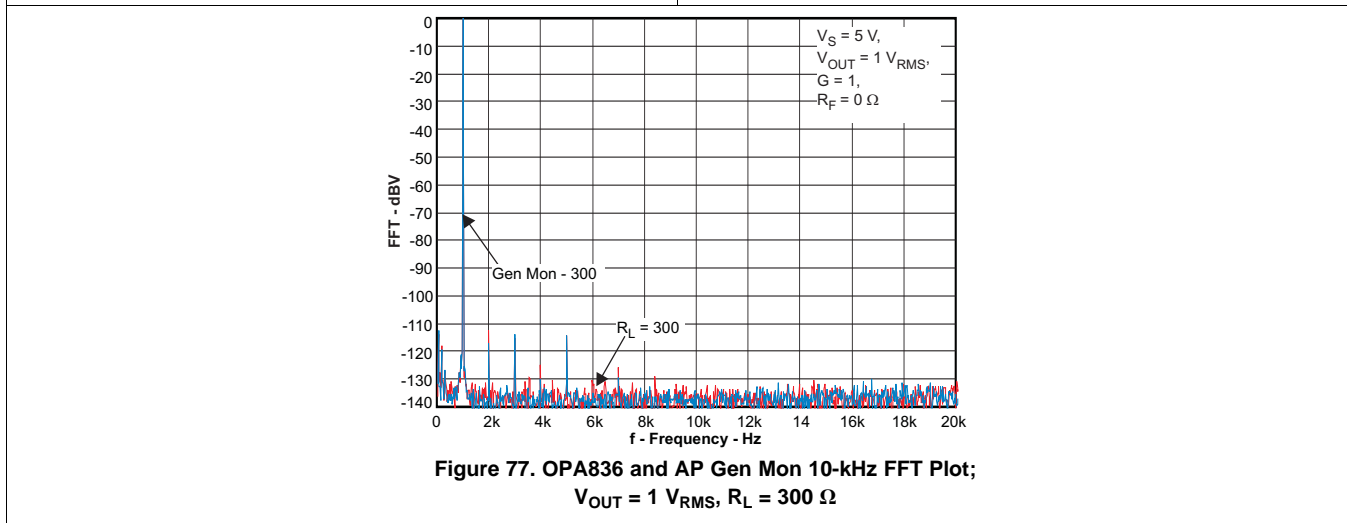
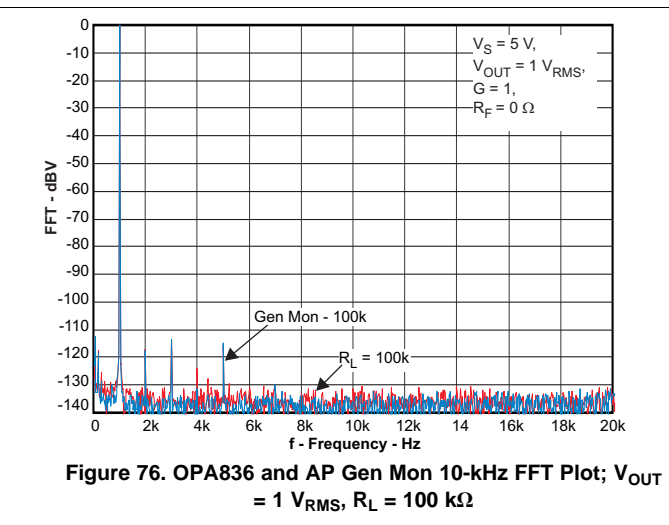
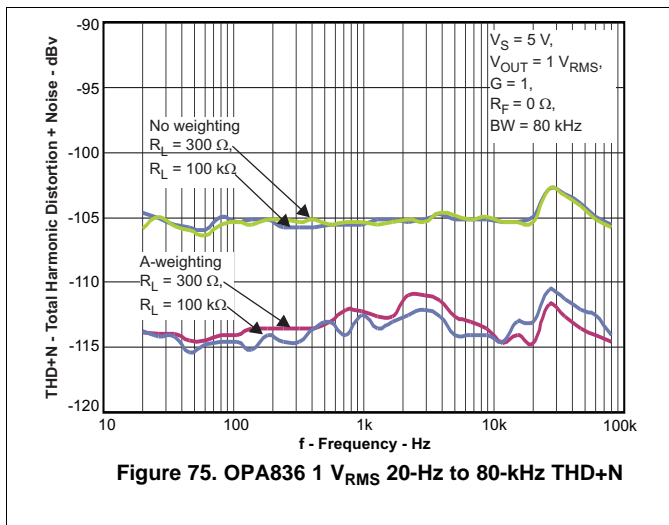
The 100-pF capacitor to ground on the input helped to decouple noise pickup in the lab and improved noise performance.

The Audio Precision was configured as a single-ended output in this application circuit. In applications where a differential output is available, the OPA836 device can be configured as a differential-to-single-ended amplifier as shown in [Figure 67](#). Power-supply bypassing is critical to reject noise from the power supplies. A 2.2-μF supply decoupling capacitor must be placed within 2 inches of the device and can be shared with other operational amplifiers on the same board. A 0.1-μF supply decoupling capacitor must be placed as close to the supply pins as possible, preferably within 0.1 inch. For a split supply, a capacitor is required for both supplies. A 0.1-μF capacitor placed directly between the supplies is also beneficial for improving system noise performance. If the output load is heavy, such as 16 Ω to 32 Ω, performance of the amplifier could begin to degrade. To drive such heavy loads, both channels of the OPA2836 device can be paralleled with their outputs isolated with 1-Ω resistors to reduce the loading effects.

### 9.2.1.3 Application Curves

Figure 75 shows the THD+N performance with 100-k $\Omega$  and 300- $\Omega$  loads, and with A-weighting and with no weighting. Both loads show similar performance. With no weighting, the THD+N performance is dominated by the noise for both loads. A-weighting provides filtering that improves the noise, revealing the increased distortion with  $R_L = 300 \Omega$ .

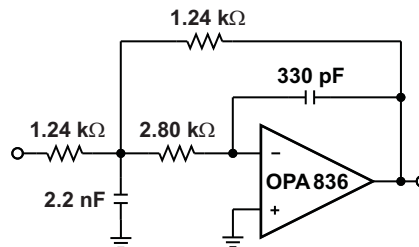
Figure 76 and Figure 77 show the FFT output with a 1-kHz tone and 100-k $\Omega$  and 300- $\Omega$  loads. To show relative performance of the device versus the test set, one channel has the OPA836 device in-line between the generator output and the analyzer. The other channel is in “Gen Mon” loopback mode, which internally connects the signal generator to the analyzer input. With 100-k $\Omega$  load, Figure 76, the curves are indistinguishable from each other except for noise, which means the OPA836 device cannot be directly measured. With 300- $\Omega$  load, as shown in Figure 77, the main difference between the curves is that the OPA836 device shows slightly higher even-order harmonics, but the performance of the test set masks the odd-order harmonics.



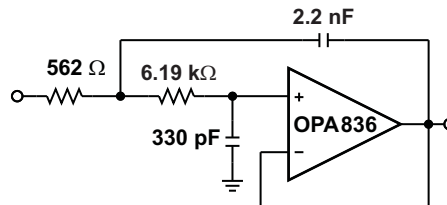
## 9.2.2 Active Filters

The OPA836 and OPA2836 devices are good choices for active filters. [Figure 78](#) and [Figure 79](#) show MFB and Sallen-Key circuits designed using the [WEBENCH® Filter Designer](#) to implement second-order low-pass Butterworth filter circuits. [Figure 80](#) shows the frequency response.

Other MFB and Sallen-Key filter circuits offer similar performance. The main difference is the MFB is an inverting amplifier in the pass-band and the Sallen-Key is noninverting. The primary advantage for each is the Sallen-Key in unity gain has no resistor gain-error term, and thus no sensitivity to gain error, while the MFB has better attenuation properties beyond the bandwidth of the operational amplifier.

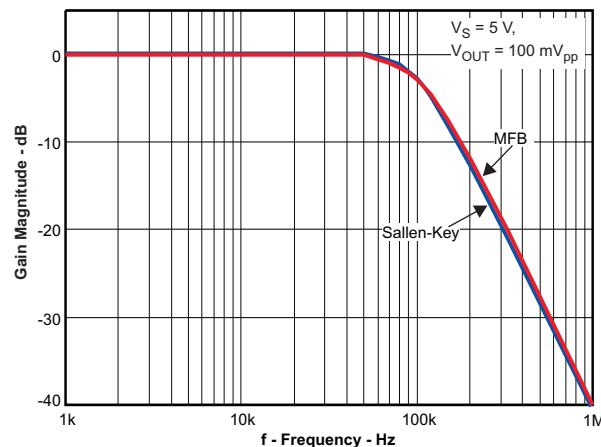


**Figure 78. MFB 100-kHz Second-Order Low-Pass Butterworth Filter Circuit**



**Figure 79. Sallen-Key 100-kHz Second-Order Low-Pass Butterworth Filter Circuit**

### 9.2.2.1 Application Curve



**Figure 80. MFB and Sallen-Key Second Order Low-Pass Butterworth Filter Response**

## 10 Power Supply Recommendations

The OPAx836 devices are intended to work in a supply range of 2.7 V to 5 V. Supply-voltage tolerances are supported with the specified operating range of 2.5 V (7% on a 2.7-V supply) and 5.5 V (10% on a 5-V supply). Good power-supply bypassing is required. Minimize the distance (< 0.1 inch) from the power-supply pins to high frequency, 0.1- $\mu$ F decoupling capacitors. A larger capacitor (2.2  $\mu$ F is typical) is used along with a high frequency, 0.1- $\mu$ F supply decoupling capacitor at the device supply pins. For single-supply operation, only the positive supply has these capacitors. When a split supply is used, use these capacitors for each supply to ground. If necessary, place the larger capacitors farther from the device and share these capacitors among several devices in the same area of the PCB. Avoid narrow power and ground traces to minimize inductance between the pins and the decoupling capacitors. An optional supply decoupling capacitor across the two power supplies (for bipolar operation) reduces second harmonic distortion.

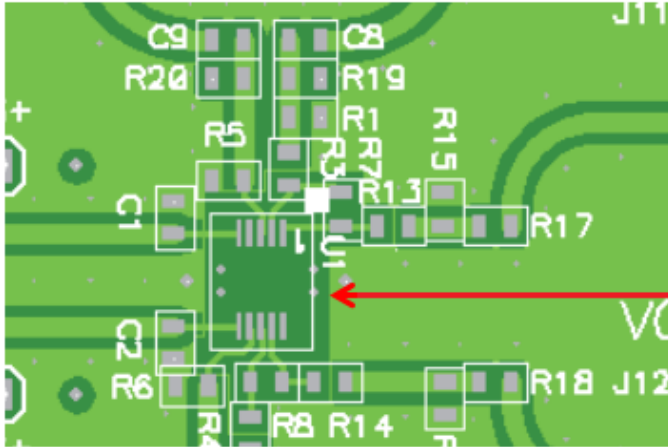
## 11 Layout

### 11.1 Layout Guidelines

The [OPA835DBV](#), [OPA836DBV EVM](#) (SLOU314) can be used as a reference when designing the circuit board. TI recommends following the EVM layout of the external components near the amplifier, ground-plane construction, and power routing. General guidelines are listed as follows:

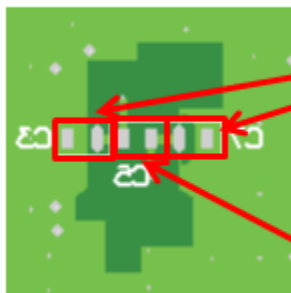
1. Signal routing must be direct and as short as possible into and out of the operational amplifier.
2. The feedback path must be short and direct avoiding vias if possible especially with  $G = +1$ .
3. Ground or power planes must be removed from directly under the negative input and output pins of the amplifier.
4. TI recommends placing a series output resistor as close to the output pin as possible. See *Series Output Resistor vs Capacitive Load* ([Figure 17](#)) for recommended values for the expected capacitive load.
5. A 2.2- $\mu$ F power-supply decoupling capacitor must be placed within two inches of the device and can be shared with other operational amplifiers. For split supply, a capacitor is required for both supplies.
6. A 0.1- $\mu$ F power-supply decoupling capacitor must be placed as close to the power supply pins as possible, preferably within 0.1 inch. For split supply, a capacitor is required for both supplies.
7. The  $\overline{\text{PD}}$  pin uses TTL logic levels. If the pin is not used, it must be tied to the positive supply to enable the amplifier. If the pin is used, it must be actively driven. A bypass capacitor is not necessary, but is used for robustness in noisy environments.

## 11.2 Layout Example



Dark green areas indicate regions of the PCB where the underlying Ground and Power Planes have been removed in order to minimize parasitic capacitance on the sensitive input and output nodes.

**Figure 81. Top Layer**



C3 and C7 are 0.1- $\mu$ F bypass capacitors placed directly underneath the device power supply pins.

C5 is a bypass capacitor between the supply pins. Use this when configuring the amplifier with bipolar supplies to improve HD2 performance.

**Figure 82. Bottom Layer**

## 12 Device and Documentation Support

### 12.1 Device Support

#### 12.1.1 Development Support

[WEBENCH® Filter Designer](#)

#### 12.1.2 Related Documentation

For related documentation see the following:

[OPA835DBV](#), [OPA836DBV EVM](#) (SLOU314).

### 12.2 Related Links

[Table 7](#) lists quick access links. Categories include technical documents, support and community resources, tools and software, and quick access to sample or buy.

**Table 7. Related Links**

PARTS	PRODUCT FOLDER	SAMPLE & BUY	TECHNICAL DOCUMENTS	TOOLS & SOFTWARE	SUPPORT & COMMUNITY
OPA836	<a href="#">Click here</a>	<a href="#">Click here</a>	<a href="#">Click here</a>	<a href="#">Click here</a>	<a href="#">Click here</a>
OPA2836	<a href="#">Click here</a>	<a href="#">Click here</a>	<a href="#">Click here</a>	<a href="#">Click here</a>	<a href="#">Click here</a>

### 12.3 Receiving Notification of Documentation Updates

To receive notification of documentation updates, navigate to the device product folder on ti.com. In the upper right corner, click on *Alert me* to register and receive a weekly digest of any product information that has changed. For change details, review the revision history included in any revised document.

### 12.4 Community Resources

The following links connect to TI community resources. Linked contents are provided "AS IS" by the respective contributors. They do not constitute TI specifications and do not necessarily reflect TI's views; see TI's [Terms of Use](#).

**TI E2E™ Online Community** *TI's Engineer-to-Engineer (E2E) Community*. Created to foster collaboration among engineers. At [e2e.ti.com](http://e2e.ti.com), you can ask questions, share knowledge, explore ideas and help solve problems with fellow engineers.

**Design Support** *TI's Design Support* Quickly find helpful E2E forums along with design support tools and contact information for technical support.

### 12.5 Trademarks

E2E is a trademark of Texas Instruments.  
 WEBENCH is a registered trademark of Texas Instruments.  
 All other trademarks are the property of their respective owners.

### 12.6 Electrostatic Discharge Caution



This integrated circuit can be damaged by ESD. Texas Instruments recommends that all integrated circuits be handled with appropriate precautions. Failure to observe proper handling and installation procedures can cause damage.

ESD damage can range from subtle performance degradation to complete device failure. Precision integrated circuits may be more susceptible to damage because very small parametric changes could cause the device not to meet its published specifications.

### 12.7 Glossary

[SLYZ022](#) — *TI Glossary*.

This glossary lists and explains terms, acronyms, and definitions.

## 13 Mechanical, Packaging, and Orderable Information

The following pages include mechanical, packaging, and orderable information. This information is the most current data available for the designated devices. This data is subject to change without notice and revision of this document. For browser-based versions of this data sheet, refer to the left-hand navigation.

**PACKAGING INFORMATION**

Orderable Device	Status (1)	Package Type	Package Drawing	Pins	Package Qty	Eco Plan (2)	Lead/Ball Finish (6)	MSL Peak Temp (3)	Op Temp (°C)	Device Marking (4/5)	Samples
OPA2836ID	ACTIVE	SOIC	D	8	75	Green (RoHS & no Sb/Br)	CU NIPDAU	Level-2-260C-1 YEAR	-40 to 125	2836	<a href="#">Samples</a>
OPA2836IDGS	ACTIVE	VSSOP	DGS	10	80	Green (RoHS & no Sb/Br)	CU NIPDAUAG	Level-2-260C-1 YEAR	-40 to 125	2836	<a href="#">Samples</a>
OPA2836IDGSR	ACTIVE	VSSOP	DGS	10	2500	Green (RoHS & no Sb/Br)	CU NIPDAUAG	Level-2-260C-1 YEAR	-40 to 125	2836	<a href="#">Samples</a>
OPA2836IDR	ACTIVE	SOIC	D	8	2500	Green (RoHS & no Sb/Br)	CU NIPDAU	Level-2-260C-1 YEAR	-40 to 125	2836	<a href="#">Samples</a>
OPA2836IRMCR	ACTIVE	UQFN	RMC	10	3000	Green (RoHS & no Sb/Br)	CU NIPDAU	Level-2-260C-1 YEAR	-40 to 125	2836	<a href="#">Samples</a>
OPA2836IRMCT	ACTIVE	UQFN	RMC	10	250	Green (RoHS & no Sb/Br)	CU NIPDAU	Level-2-260C-1 YEAR	-40 to 125	2836	<a href="#">Samples</a>
OPA2836IRUNR	ACTIVE	QFN	RUN	10	3000	Green (RoHS & no Sb/Br)	CU NIPDAU	Level-2-260C-1 YEAR	-40 to 125	2836	<a href="#">Samples</a>
OPA2836IRUNT	ACTIVE	QFN	RUN	10	250	Green (RoHS & no Sb/Br)	CU NIPDAU	Level-2-260C-1 YEAR	-40 to 125	2836	<a href="#">Samples</a>
OPA836IDBVR	ACTIVE	SOT-23	DBV	6	3000	Green (RoHS & no Sb/Br)	CU SN	Level-1-260C-UNLIM	-40 to 125	QTL	<a href="#">Samples</a>
OPA836IDBVT	ACTIVE	SOT-23	DBV	6	250	Green (RoHS & no Sb/Br)	CU SN	Level-1-260C-UNLIM	-40 to 125	QTL	<a href="#">Samples</a>
OPA836IRUNR	ACTIVE	QFN	RUN	10	3000	Green (RoHS & no Sb/Br)	CU NIPDAU	Level-2-260C-1 YEAR	-40 to 125	836	<a href="#">Samples</a>
OPA836IRUNT	ACTIVE	QFN	RUN	10	250	Green (RoHS & no Sb/Br)	CU NIPDAU	Level-2-260C-1 YEAR	-40 to 125	836	<a href="#">Samples</a>

(1) The marketing status values are defined as follows:

**ACTIVE:** Product device recommended for new designs.

**LIFEBUY:** TI has announced that the device will be discontinued, and a lifetime-buy period is in effect.

**NRND:** Not recommended for new designs. Device is in production to support existing customers, but TI does not recommend using this part in a new design.

**PREVIEW:** Device has been announced but is not in production. Samples may or may not be available.

**OBSELETE:** TI has discontinued the production of the device.

(2) **RoHS:** TI defines "RoHS" to mean semiconductor products that are compliant with the current EU RoHS requirements for all 10 RoHS substances, including the requirement that RoHS substance do not exceed 0.1% by weight in homogeneous materials. Where designed to be soldered at high temperatures, "RoHS" products are suitable for use in specified lead-free processes. TI may reference these types of products as "Pb-Free".

**RoHS Exempt:** TI defines "RoHS Exempt" to mean products that contain lead but are compliant with EU RoHS pursuant to a specific EU RoHS exemption.

---

**Green:** TI defines "Green" to mean the content of Chlorine (Cl) and Bromine (Br) based flame retardants meet JS709B low halogen requirements of  $\leq 1000$ ppm threshold. Antimony trioxide based flame retardants must also meet the  $\leq 1000$ ppm threshold requirement.

(3) MSL, Peak Temp. - The Moisture Sensitivity Level rating according to the JEDEC industry standard classifications, and peak solder temperature.

(4) There may be additional marking, which relates to the logo, the lot trace code information, or the environmental category on the device.

(5) Multiple Device Markings will be inside parentheses. Only one Device Marking contained in parentheses and separated by a "~" will appear on a device. If a line is indented then it is a continuation of the previous line and the two combined represent the entire Device Marking for that device.

(6) Lead/Ball Finish - Orderable Devices may have multiple material finish options. Finish options are separated by a vertical ruled line. Lead/Ball Finish values may wrap to two lines if the finish value exceeds the maximum column width.

**Important Information and Disclaimer:** The information provided on this page represents TI's knowledge and belief as of the date that it is provided. TI bases its knowledge and belief on information provided by third parties, and makes no representation or warranty as to the accuracy of such information. Efforts are underway to better integrate information from third parties. TI has taken and continues to take reasonable steps to provide representative and accurate information but may not have conducted destructive testing or chemical analysis on incoming materials and chemicals. TI and TI suppliers consider certain information to be proprietary, and thus CAS numbers and other limited information may not be available for release.

In no event shall TI's liability arising out of such information exceed the total purchase price of the TI part(s) at issue in this document sold by TI to Customer on an annual basis.

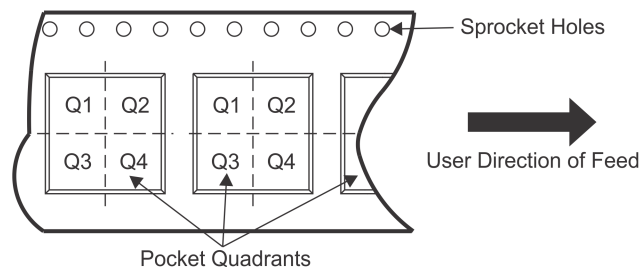
**OTHER QUALIFIED VERSIONS OF OPA2836 :**

- Automotive: [OPA2836-Q1](#)

NOTE: Qualified Version Definitions:

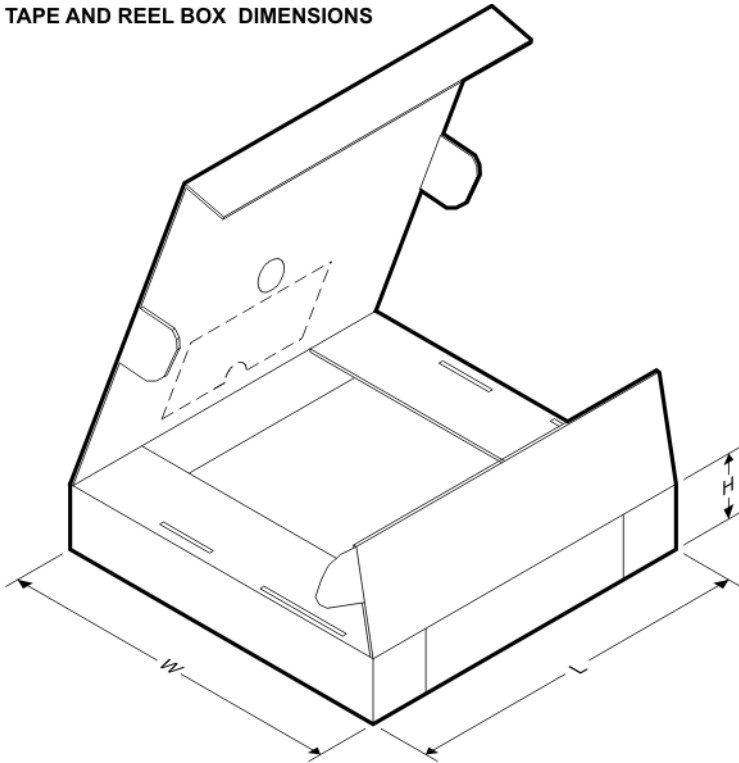
- Automotive - Q100 devices qualified for high-reliability automotive applications targeting zero defects

**TAPE AND REEL INFORMATION**

**QUADRANT ASSIGNMENTS FOR PIN 1 ORIENTATION IN TAPE**


\*All dimensions are nominal

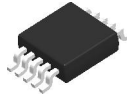
Device	Package Type	Package Drawing	Pins	SPQ	Reel Diameter (mm)	Reel Width W1 (mm)	A0 (mm)	B0 (mm)	K0 (mm)	P1 (mm)	W (mm)	Pin1 Quadrant
OPA2836IDGSR	VSSOP	DGS	10	2500	330.0	12.4	5.3	3.4	1.4	8.0	12.0	Q1
OPA2836IDR	SOIC	D	8	2500	330.0	12.4	6.4	5.2	2.1	8.0	12.0	Q1
OPA2836IRMCR	UQFN	RMC	10	3000	180.0	9.5	2.3	2.3	1.1	2.0	8.0	Q2
OPA2836IRMCT	UQFN	RMC	10	250	180.0	9.5	2.3	2.3	1.1	2.0	8.0	Q2
OPA2836IRUNR	QFN	RUN	10	3000	180.0	8.4	2.3	2.3	1.15	4.0	8.0	Q2
OPA2836IRUNT	QFN	RUN	10	250	180.0	8.4	2.3	2.3	1.15	4.0	8.0	Q2
OPA836IDBVR	SOT-23	DBV	6	3000	178.0	9.0	3.23	3.17	1.37	4.0	8.0	Q3
OPA836IDBVT	SOT-23	DBV	6	250	178.0	9.0	3.23	3.17	1.37	4.0	8.0	Q3
OPA836IRUNR	QFN	RUN	10	3000	180.0	8.4	2.3	2.3	1.15	4.0	8.0	Q2
OPA836IRUNT	QFN	RUN	10	250	180.0	8.4	2.3	2.3	1.15	4.0	8.0	Q2

**TAPE AND REEL BOX DIMENSIONS**


\*All dimensions are nominal

Device	Package Type	Package Drawing	Pins	SPQ	Length (mm)	Width (mm)	Height (mm)
OPA2836IDGSR	VSSOP	DGS	10	2500	366.0	364.0	50.0
OPA2836IDR	SOIC	D	8	2500	340.5	338.1	20.6
OPA2836IRMCR	UQFN	RMC	10	3000	205.0	200.0	30.0
OPA2836IRMCT	UQFN	RMC	10	250	205.0	200.0	30.0
OPA2836IRUNR	QFN	RUN	10	3000	210.0	185.0	35.0
OPA2836IRUNT	QFN	RUN	10	250	210.0	185.0	35.0
OPA836IDBVR	SOT-23	DBV	6	3000	180.0	180.0	18.0
OPA836IDBVT	SOT-23	DBV	6	250	180.0	180.0	18.0
OPA836IRUNR	QFN	RUN	10	3000	210.0	185.0	35.0
OPA836IRUNT	QFN	RUN	10	250	210.0	185.0	35.0

# DGS0010A



# PACKAGE OUTLINE

## VSSOP - 1.1 mm max height

SMALL OUTLINE PACKAGE



4221984/A 05/2015

**NOTES:**

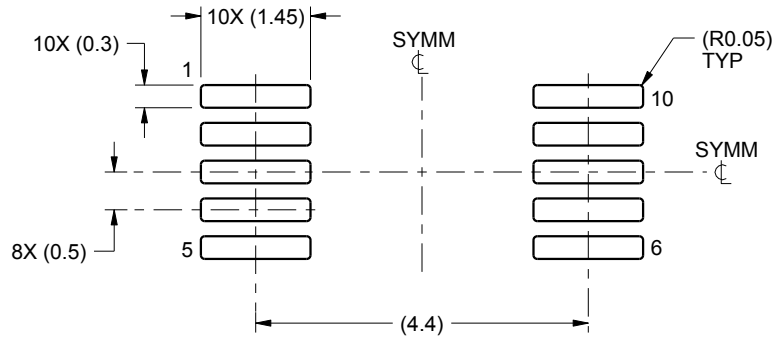
1. All linear dimensions are in millimeters. Any dimensions in parenthesis are for reference only. Dimensioning and tolerancing per ASME Y14.5M.
2. This drawing is subject to change without notice.
3. This dimension does not include mold flash, protrusions, or gate burrs. Mold flash, protrusions, or gate burrs shall not exceed 0.15 mm per side.
4. This dimension does not include interlead flash. Interlead flash shall not exceed 0.25 mm per side.
5. Reference JEDEC registration MO-187, variation BA.

# EXAMPLE BOARD LAYOUT

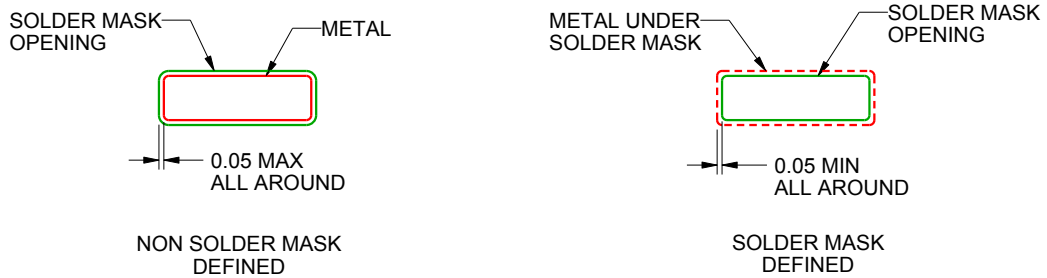
DGS0010A

VSSOP - 1.1 mm max height

SMALL OUTLINE PACKAGE



LAND PATTERN EXAMPLE  
SCALE:10X



SOLDER MASK DETAILS  
NOT TO SCALE

4221984/A 05/2015

NOTES: (continued)

- 6. Publication IPC-7351 may have alternate designs.
- 7. Solder mask tolerances between and around signal pads can vary based on board fabrication site.

# EXAMPLE STENCIL DESIGN

DGS0010A

VSSOP - 1.1 mm max height

SMALL OUTLINE PACKAGE



SOLDER PASTE EXAMPLE  
BASED ON 0.125 mm THICK STENCIL  
SCALE:10X

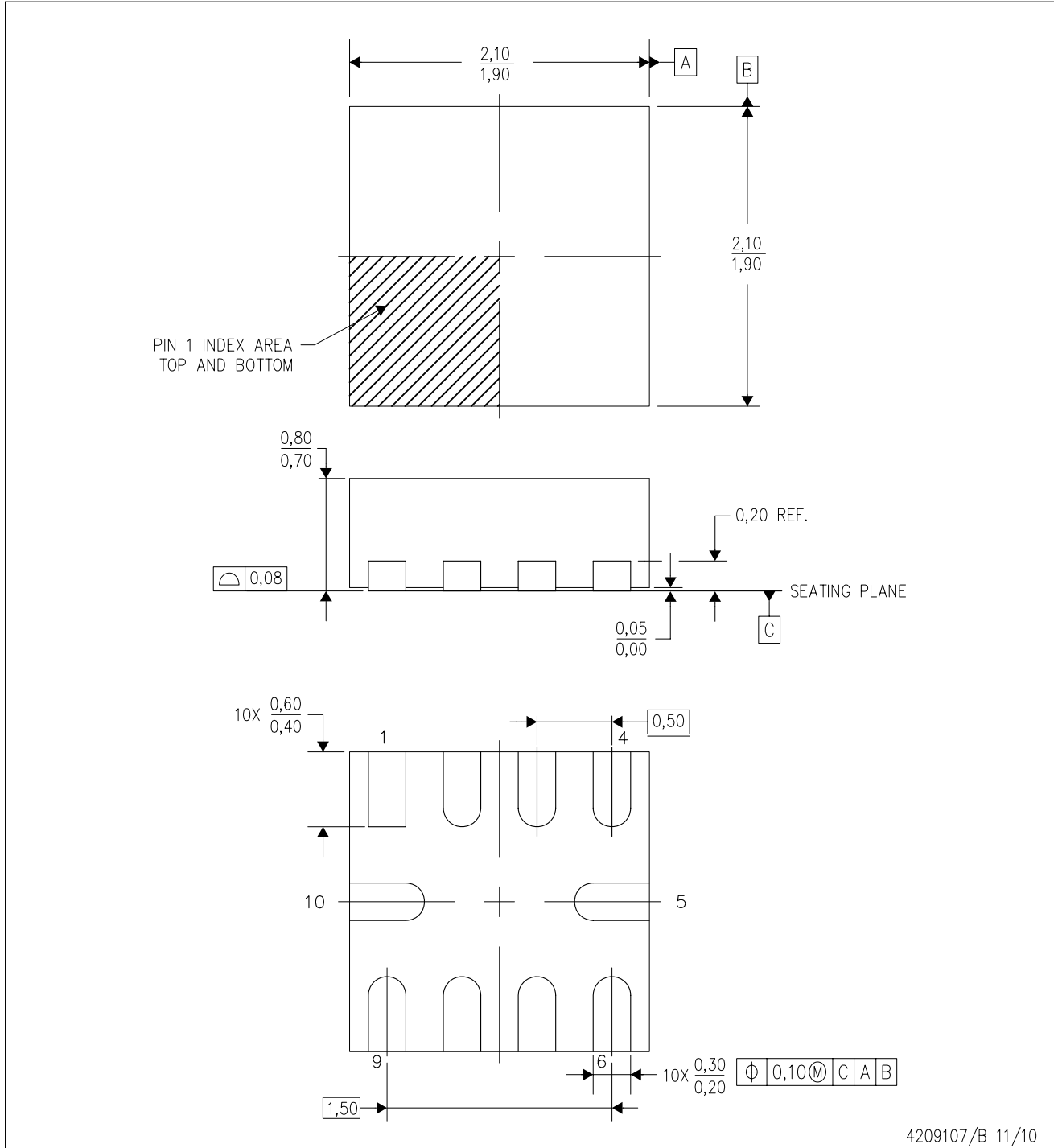
4221984/A 05/2015

NOTES: (continued)

8. Laser cutting apertures with trapezoidal walls and rounded corners may offer better paste release. IPC-7525 may have alternate design recommendations.
9. Board assembly site may have different recommendations for stencil design.

RUN (S-PWQFN-N10)

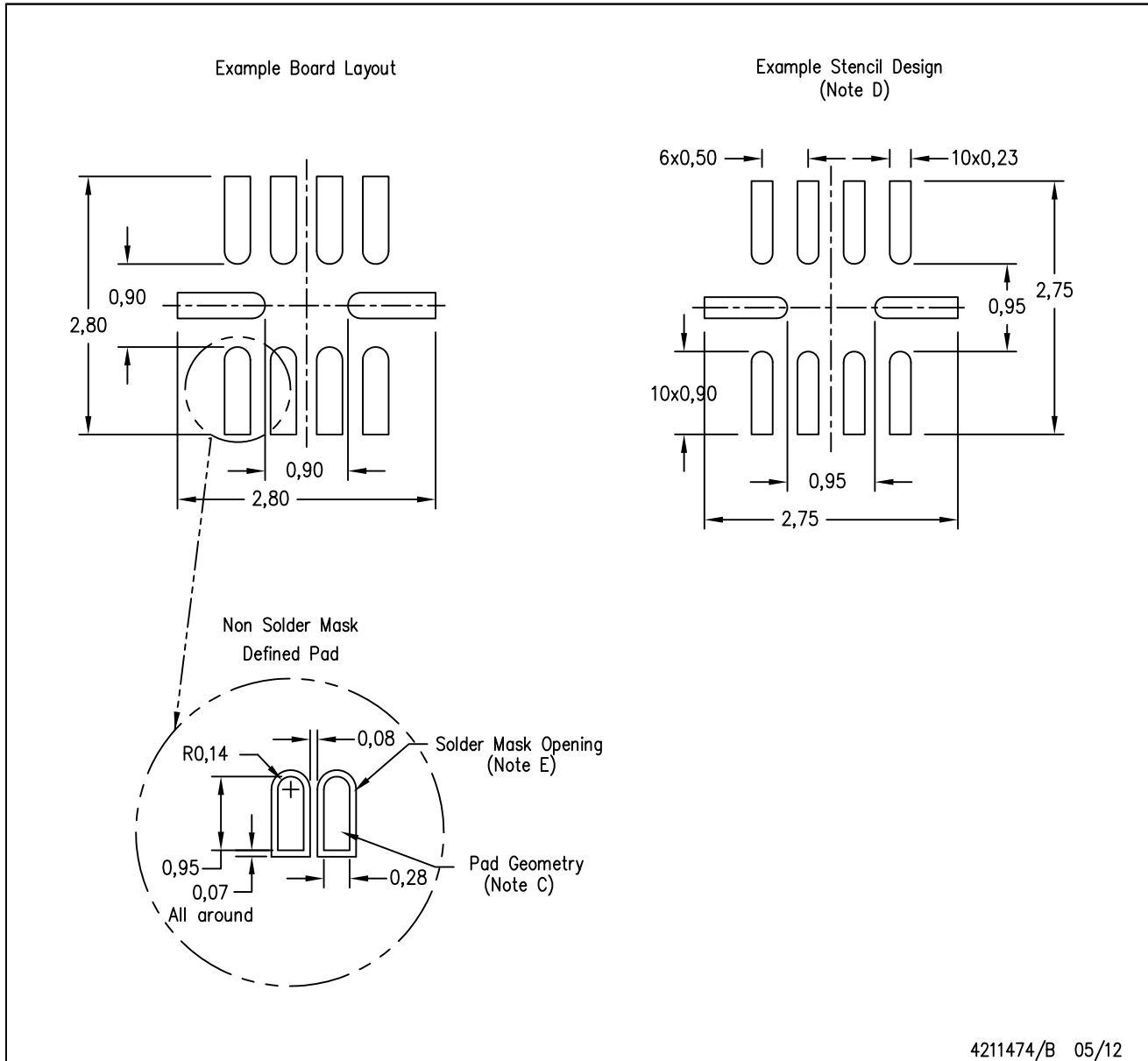
PLASTIC QUAD FLATPACK NO-LEAD



- NOTES:
- A. All linear dimensions are in millimeters. Dimensioning and tolerancing per ASME Y14.5M-1994.
  - B. This drawing is subject to change without notice.
  - C. Quad Flatpack, No-Leads (QFN) package configuration.

RUN (S-PWQFN-N10)

PLASTIC QUAD FLATPACK NO-LEAD



- NOTES:
- A. All linear dimensions are in millimeters.
  - B. This drawing is subject to change without notice.
  - C. Publication IPC-7351 is recommended for alternate designs.
  - D. Laser cutting apertures with trapezoidal walls and also rounding corners will offer better paste release. Customers should contact their board assembly site for stencil design recommendations. Refer to IPC 7525 for stencil design considerations.
  - E. Customers should contact their board fabrication site for minimum solder mask web tolerances between signal pads.



D0008A

# PACKAGE OUTLINE

SOIC - 1.75 mm max height

SMALL OUTLINE INTEGRATED CIRCUIT



4214825/C 02/2019

### NOTES:

- Linear dimensions are in inches [millimeters]. Dimensions in parenthesis are for reference only. Controlling dimensions are in inches. Dimensioning and tolerancing per ASME Y14.5M.
- This drawing is subject to change without notice.
- This dimension does not include mold flash, protrusions, or gate burrs. Mold flash, protrusions, or gate burrs shall not exceed  $.006$  [0.15] per side.
- This dimension does not include interlead flash.
- Reference JEDEC registration MS-012, variation AA.

# EXAMPLE BOARD LAYOUT

D0008A

SOIC - 1.75 mm max height

SMALL OUTLINE INTEGRATED CIRCUIT



LAND PATTERN EXAMPLE  
EXPOSED METAL SHOWN  
SCALE:8X



SOLDER MASK DETAILS

4214825/C 02/2019

NOTES: (continued)

- 6. Publication IPC-7351 may have alternate designs.
- 7. Solder mask tolerances between and around signal pads can vary based on board fabrication site.

# EXAMPLE STENCIL DESIGN

D0008A

SOIC - 1.75 mm max height

SMALL OUTLINE INTEGRATED CIRCUIT



SOLDER PASTE EXAMPLE  
BASED ON .005 INCH [0.125 MM] THICK STENCIL  
SCALE:8X

4214825/C 02/2019

NOTES: (continued)

8. Laser cutting apertures with trapezoidal walls and rounded corners may offer better paste release. IPC-7525 may have alternate design recommendations.
9. Board assembly site may have different recommendations for stencil design.

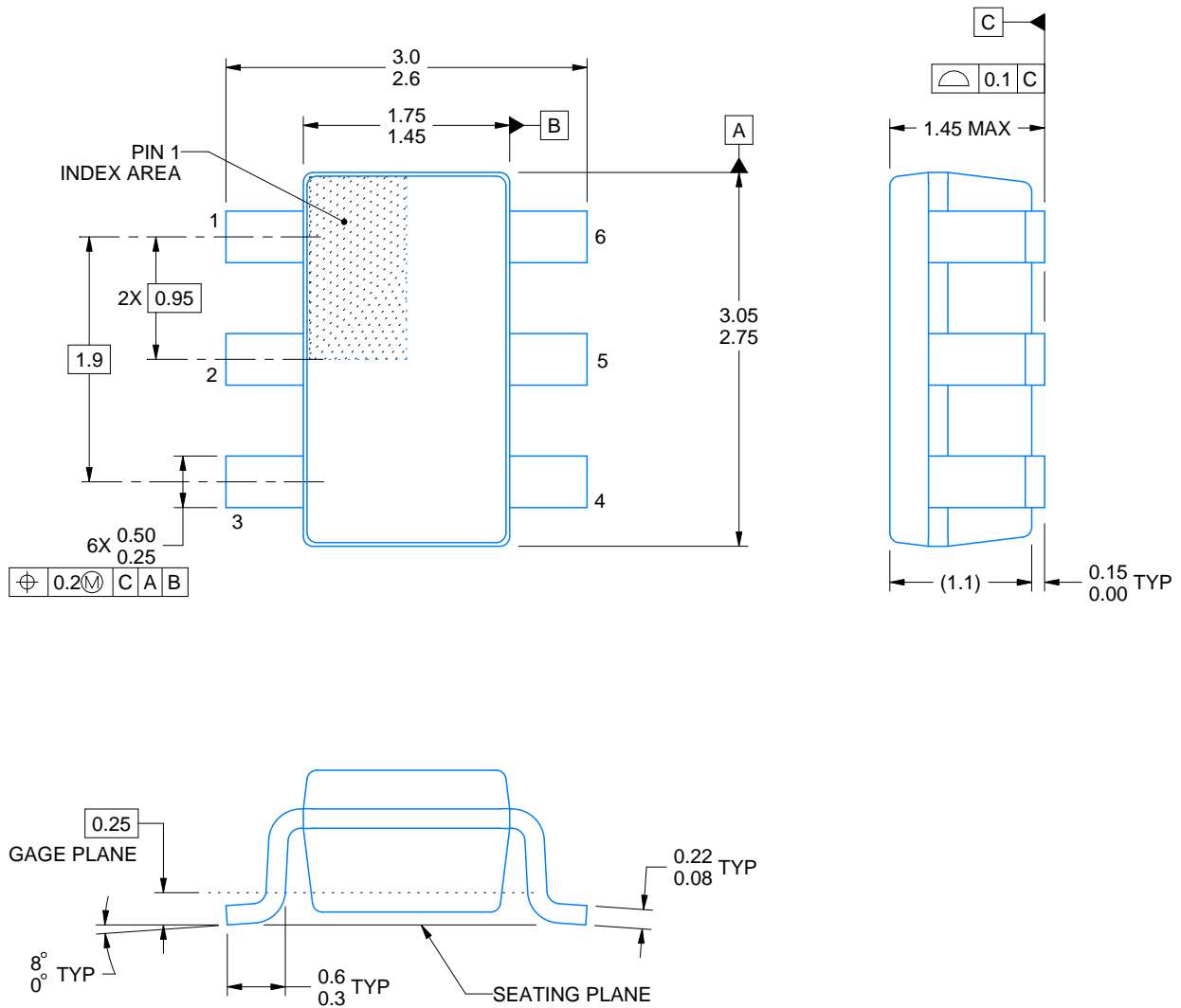
DBV0006A



# PACKAGE OUTLINE

SOT-23 - 1.45 mm max height

SMALL OUTLINE TRANSISTOR



4214840/B 03/2018

## NOTES:

1. All linear dimensions are in millimeters. Any dimensions in parenthesis are for reference only. Dimensioning and tolerancing per ASME Y14.5M.
2. This drawing is subject to change without notice.
3. Body dimensions do not include mold flash or protrusion. Mold flash and protrusion shall not exceed 0.15 per side.
4. Leads 1,2,3 may be wider than leads 4,5,6 for package orientation.
5. Reference JEDEC MO-178.

# EXAMPLE BOARD LAYOUT

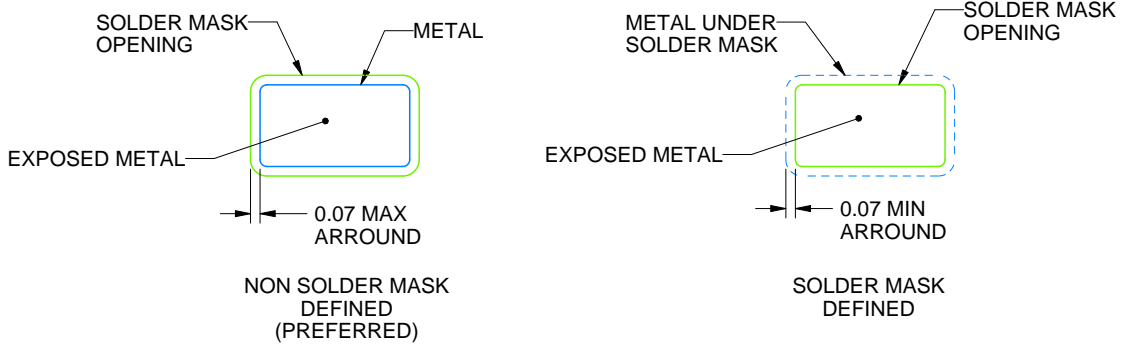
DBV0006A

SOT-23 - 1.45 mm max height

SMALL OUTLINE TRANSISTOR



LAND PATTERN EXAMPLE  
EXPOSED METAL SHOWN  
SCALE:15X



SOLDER MASK DETAILS

4214840/B 03/2018

NOTES: (continued)

- 6. Publication IPC-7351 may have alternate designs.
- 7. Solder mask tolerances between and around signal pads can vary based on board fabrication site.

# EXAMPLE STENCIL DESIGN

DBV0006A

SOT-23 - 1.45 mm max height

SMALL OUTLINE TRANSISTOR



SOLDER PASTE EXAMPLE  
BASED ON 0.125 mm THICK STENCIL  
SCALE:15X

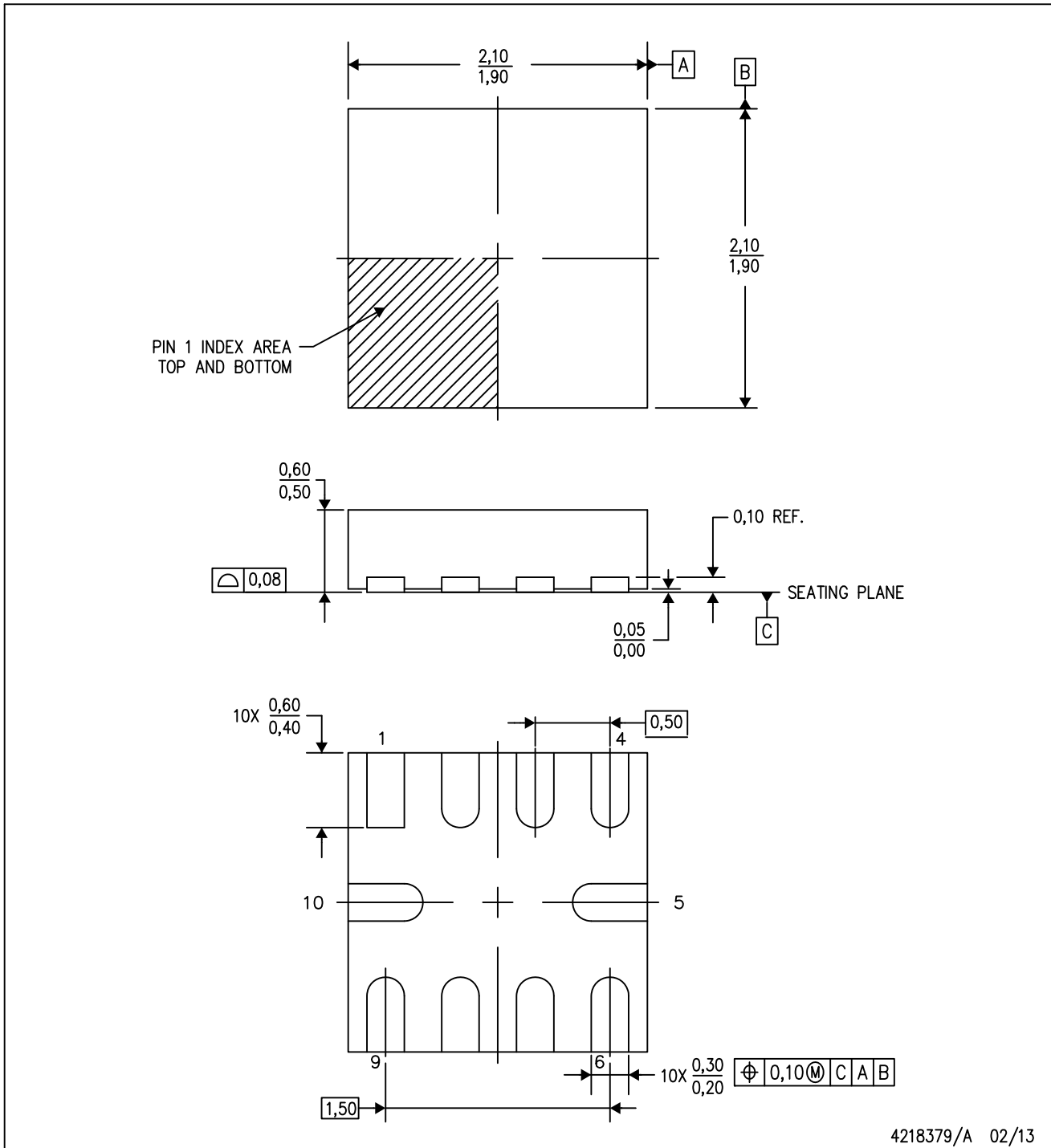
4214840/B 03/2018

NOTES: (continued)

8. Laser cutting apertures with trapezoidal walls and rounded corners may offer better paste release. IPC-7525 may have alternate design recommendations.
9. Board assembly site may have different recommendations for stencil design.

RMC (S-PUQFN-N10)

PLASTIC QUAD FLATPACK NO-LEAD

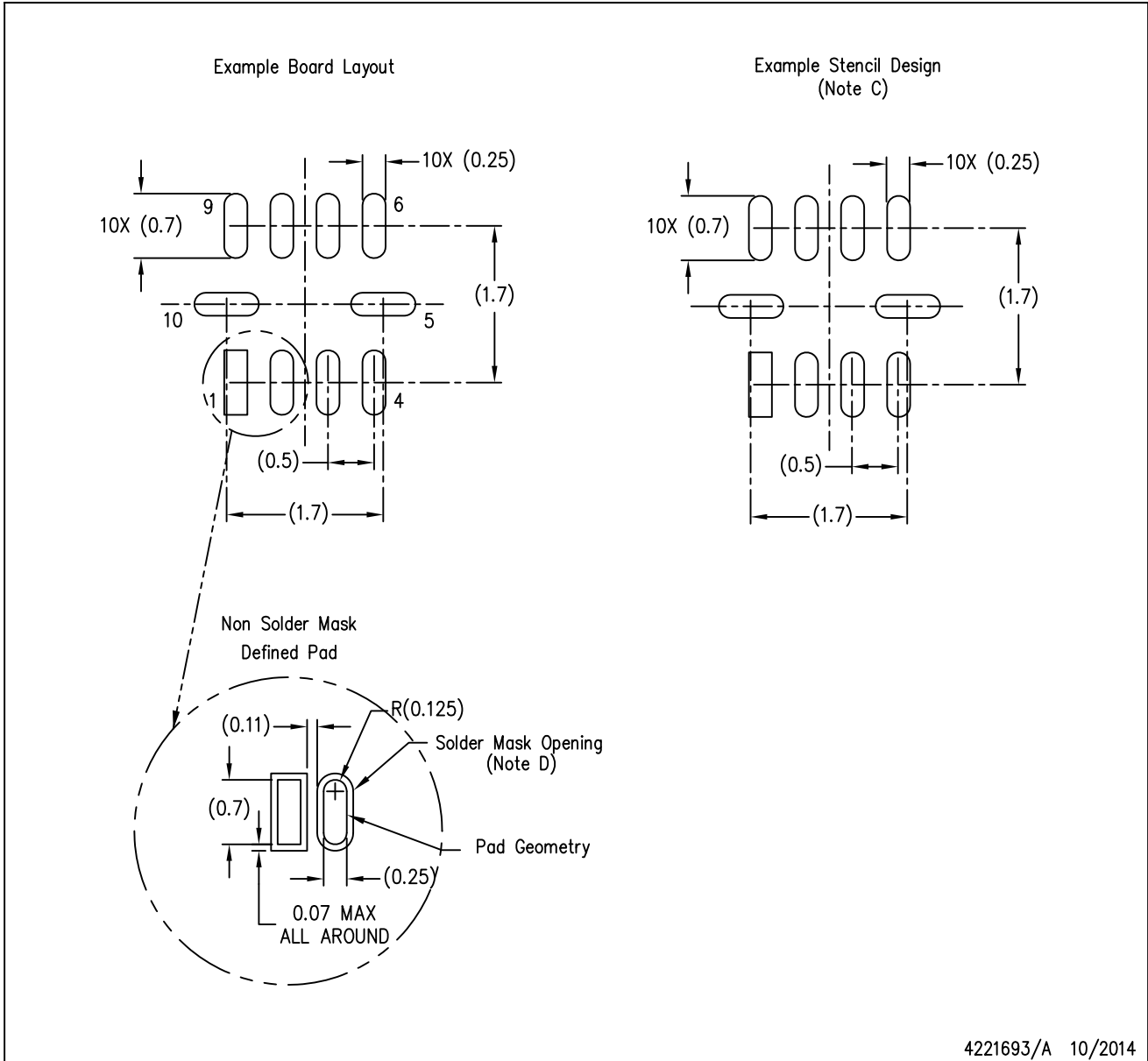


4218379/A 02/13

- NOTES:
- A. All linear dimensions are in millimeters. Dimensioning and tolerancing per ASME Y14.5M-1994.
  - B. This drawing is subject to change without notice.
  - C. Quad Flatpack, No-Leads (QFN) package configuration.

RMC (S-PUQFN-N10)

PLASTIC QUAD FLATPACK NO-LEAD



- NOTES:
- A. All linear dimensions are in millimeters. Dimensions in parenthesis are for reference only.
  - B. This drawing is subject to change without notice.
  - C. Laser cutting apertures with trapezoidal walls and also rounding corners will offer better paste release. Customers should contact their board assembly site for stencil design recommendations. Refer to IPC 7525 for stencil design considerations.
  - D. Customers should contact their board fabrication site for minimum solder mask web tolerances between signal pads.

## IMPORTANT NOTICE AND DISCLAIMER

TI PROVIDES TECHNICAL AND RELIABILITY DATA (INCLUDING DATASHEETS), DESIGN RESOURCES (INCLUDING REFERENCE DESIGNS), APPLICATION OR OTHER DESIGN ADVICE, WEB TOOLS, SAFETY INFORMATION, AND OTHER RESOURCES "AS IS" AND WITH ALL FAULTS, AND DISCLAIMS ALL WARRANTIES, EXPRESS AND IMPLIED, INCLUDING WITHOUT LIMITATION ANY IMPLIED WARRANTIES OF MERCHANTABILITY, FITNESS FOR A PARTICULAR PURPOSE OR NON-INFRINGEMENT OF THIRD PARTY INTELLECTUAL PROPERTY RIGHTS.

These resources are intended for skilled developers designing with TI products. You are solely responsible for (1) selecting the appropriate TI products for your application, (2) designing, validating and testing your application, and (3) ensuring your application meets applicable standards, and any other safety, security, or other requirements. These resources are subject to change without notice. TI grants you permission to use these resources only for development of an application that uses the TI products described in the resource. Other reproduction and display of these resources is prohibited. No license is granted to any other TI intellectual property right or to any third party intellectual property right. TI disclaims responsibility for, and you will fully indemnify TI and its representatives against, any claims, damages, costs, losses, and liabilities arising out of your use of these resources.

TI's products are provided subject to TI's Terms of Sale ([www.ti.com/legal/termsofsale.html](http://www.ti.com/legal/termsofsale.html)) or other applicable terms available either on [ti.com](http://ti.com) or provided in conjunction with such TI products. TI's provision of these resources does not expand or otherwise alter TI's applicable warranties or warranty disclaimers for TI products.

Mailing Address: Texas Instruments, Post Office Box 655303, Dallas, Texas 75265  
Copyright © 2019, Texas Instruments Incorporated

## Looking for pricing, stock, or lifecycle information?

Click below to explore more details on WIN SOURCE:

 [View OPA2836IDGSR](#) on WIN SOURCE

 [Texas Instruments](#) Information

## Optimize Your Supply Chain with WIN SOURCE Solutions

-  Global Sourcing Solution
-  Obsolete Management
-  Cost Control Management
-  Shortage Management
-  Alternative Solution
-  Excess Inventory Management