



THE DATASHEET OF OPA27GPG4





Ultra-Low Noise, Precision OPERATIONAL AMPLIFIERS

FEATURES

- **LOW NOISE:** $4.5\text{nV}/\sqrt{\text{Hz}}$ max at 1kHz
- **LOW OFFSET:** 100 μV max
- **LOW DRIFT:** 0.4 $\mu\text{V}/^\circ\text{C}$
- **HIGH OPEN-LOOP GAIN:** 117dB min
- **HIGH COMMON-MODE REJECTION:** 100dB min
- **HIGH POWER-SUPPLY REJECTION:** 94dB min
- **FITS OP-07, OP-05, AD510, AND AD517 SOCKETS**

APPLICATIONS

- PRECISION INSTRUMENTATION
- DATA ACQUISITION
- TEST EQUIPMENT
- PROFESSIONAL AUDIO EQUIPMENT
- TRANSDUCER AMPLIFIERS
- RADIATION HARD EQUIPMENT

DESCRIPTION

The OPA27 and OPA37 are ultra-low noise, high-precision monolithic operational amplifiers.

Laser-trimmed thin-film resistors provide excellent long-term voltage offset stability and allow superior voltage offset compared to common zener-zap techniques.

A unique bias current cancellation circuit allows bias and offset current specifications to be met over the full -40°C to $+85^\circ\text{C}$ temperature range.

The OPA27 is internally compensated for unity-gain stability. The decompensated OPA37 requires a closed-loop gain ≥ 5 .

The Texas Instruments' OPA27 and OPA37 are improved replacements for the industry-standard OP-27 and OP-37.

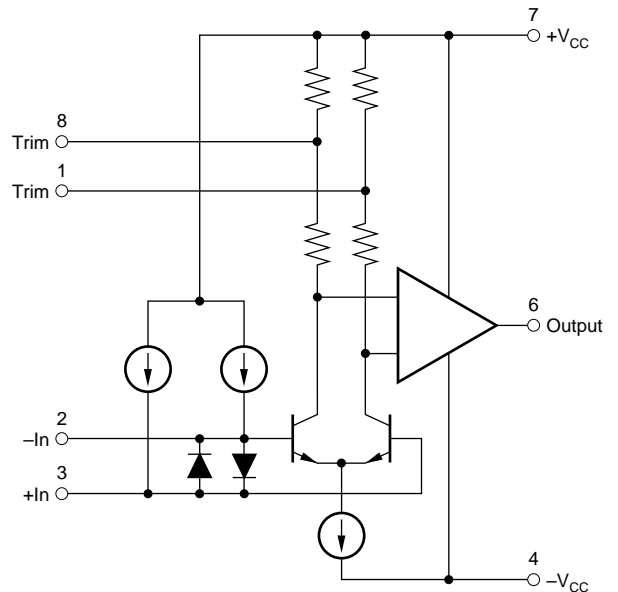

Please be aware that an important notice concerning availability, standard warranty, and use in critical applications of Texas Instruments semiconductor products and disclaimers thereto appears at the end of this data sheet.

All trademarks are the property of their respective owners.

ABSOLUTE MAXIMUM RATINGS⁽¹⁾

Supply Voltage	±22V
Internal Power Dissipation ⁽²⁾	500mW
Input Voltage	±V _{CC}
Output Short-Circuit Duration ⁽³⁾	Indefinite
Differential Input Voltage ⁽⁴⁾	±0.7V
Differential Input Current ⁽⁴⁾	±25mA
Storage Temperature Range	-55°C to +125°C
Operating Temperature Range	-40°C to +85°C
Lead Temperature:	
P (soldering, 10s)	+300°C
U (soldering, 3s)	+260°C

NOTES: (1) Stresses above these ratings may cause permanent damage. Exposure to absolute maximum conditions for extended periods may degrade device reliability. (2) Maximum package power dissipation versus ambient temperature. (2) To common with ±V_{CC} = 15V. (4) The inputs are protected by back-to-back diodes. Current limiting resistors are not used in order to achieve low noise. If differential input voltage exceeds ±0.7V, the input current should be limited to 25mA.

PACKAGE/ORDERING INFORMATION⁽¹⁾

PRODUCT	PACKAGE-LEAD	θ_{JA}	PACKAGE DRAWING	PACKAGE MARKING
OPA27	DIP-8	100°C/W	P	OPA27GP
OPA27	SO-8	160°C/W	D	OPA27U
OPA37	DIP-8	100°C/W	P	OPA37GP
OPA37	SO-8	160°C/W	D	OPA37U

NOTE: (1) For the most current package and ordering information, see the Package Option Addendum located at the end of this document, or see the TI website at www.ti.com.



ELECTROSTATIC DISCHARGE SENSITIVITY

This integrated circuit can be damaged by ESD. Texas Instruments recommends that all integrated circuits be handled with appropriate precautions. Failure to observe proper handling and installation procedures can cause damage.

ESD damage can range from subtle performance degradation to complete device failure. Precision integrated circuits may be more susceptible to damage because very small parametric changes could cause the device not to meet its published specifications.

PIN CONFIGURATION

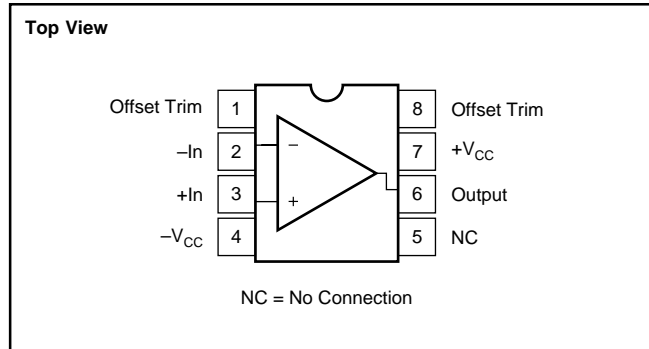

ELECTRICAL CHARACTERISTICS

At $V_{CC} = \pm 15V$ and $T_A = +25^\circ C$, unless otherwise noted.

PARAMETER	CONDITIONS	OPA27 OPA37			UNITS
		MIN	TYP	MAX	
INPUT NOISE ⁽⁶⁾ Voltage, $f_o = 10Hz$ $f_o = 30Hz$ $f_o = 1kHz$ $f_B = 0.1Hz$ to $10Hz$ Current, ⁽¹⁾ $f_o = 10Hz$ $f_o = 30Hz$ $f_o = 1kHz$			3.8 3.3 3.2 0.09 1.7 1.0 0.4	8.0 5.6 4.5 0.25	nV/\sqrt{Hz} nV/\sqrt{Hz} nV/\sqrt{Hz} μV_{PP} pA/\sqrt{Hz} pA/\sqrt{Hz} pA/\sqrt{Hz}
OFFSET VOLTAGE ⁽²⁾ Input Offset Voltage Average Drift ⁽³⁾ Long Term Stability ⁽⁴⁾ Supply Rejection	$T_{A\ MIN}$ to $T_{A\ MAX}$ $\pm V_{CC} = 4$ to $18V$ $\pm V_{CC} = 4$ to $18V$		± 25 ± 0.4 0.4 120 ± 1	± 100 $\pm 1.8^{(6)}$ 2.0 ± 20	μV $\mu V/^\circ C$ $\mu V/mo$ dB $\mu V/V$
BIAS CURRENT Input Bias Current			± 15	± 80	nA
OFFSET CURRENT Input Offset Current			10	75	nA
IMPEDANCE Common-Mode				$2 \parallel 2.5$	$G\Omega \parallel pF$
VOLTAGE RANGE Common-Mode Input Range Common-Mode Rejection	$V_{IN} = \pm 11VDC$	± 11 100	± 12.3 122		V dB
OPEN-LOOP VOLTAGE GAIN, DC	$R_L \geq 2k\Omega$ $R_L \geq 1k\Omega$	117	124 124		dB dB
FREQUENCY RESPONSE Gain-Bandwidth Product ⁽⁵⁾ Slew Rate ⁽⁵⁾ Settling Time, 0.01%	OPA27 OPA37 $V_O = \pm 10V,$ $R_L = 2k\Omega$ OPA27, $G = +1$ OPA37, $G = +5$ OPA27, $G = +1$ OPA37, $G = +5$	$5^{(6)}$ $45^{(6)}$ $1.7^{(6)}$ $11^{(6)}$	8 63 1.9 11.9 25 25		MHz MHz $V/\mu s$ $V/\mu s$ μs μs
RATED OUTPUT Voltage Output Output Resistance Short Circuit Current	$R_L \geq 2k\Omega$ $R_L \geq 600\Omega$ DC, Open Loop $R_L = 0\Omega$	± 12 ± 10	± 13.8 ± 12.8 70 25	$60^{(6)}$	V V Ω mA
POWER SUPPLY Rated Voltage Voltage Range, Derated Performance Current, Quiescent	$I_O = 0mADC$	± 4	± 15 3.3	± 22 5.7	VDC VDC mA
TEMPERATURE RANGE Specification Operating		-40 -40		+85 +85	$^\circ C$ $^\circ C$

NOTES: (1) Measured with industry-standard noise test circuit (Figures 1 and 2). Due to errors introduced by this method, these current noise specifications should be used for comparison purposes only. (2) Offset voltage specification are measured with automatic test equipment after approximately 0.5 seconds from power turn-on. (3) Unnulled or nulled with $8k\Omega$ to $20k\Omega$ potentiometer. (4) Long-term voltage offset vs time trend line does not include warm-up drift. (5) Typical specification only on plastic package units. Slew rate varies on all units due to differing test methods. Minimum specification applies to open-loop test. (6) This parameter specified by design.

ELECTRICAL CHARACTERISTICS (Cont.)

At $V_{CC} = \pm 15V$ and $-40^{\circ}C \leq T_A \leq +85^{\circ}C$, unless otherwise noted.

PARAMETER	CONDITIONS	OPA27 OPA37			UNITS
		MIN	TYP	MAX	
INPUT VOLTAGE ⁽¹⁾ Input Offset Voltage Average Drift ⁽²⁾ Supply Rejection	$T_{A\ MIN}$ to $T_{A\ MAX}$ $\pm V_{CC} = 4.5$ to $18V$ $\pm V_{CC} = 4.5$ to $18V$		± 48 ± 0.4	$\pm 220^{(3)}$ $\pm 1.8^{(3)}$	μV $\mu V/^{\circ}C$ dB
BIAS CURRENT Input Bias Current			± 21	$\pm 150^{(3)}$	nA
OFFSET CURRENT Input Offset Current			20	$135^{(3)}$	nA
VOLTAGE RANGE Common-Mode Input Range Common-Mode Rejection	$V_{IN} = \pm 11VDC$	$\pm 10.5^{(3)}$ $96^{(3)}$	± 11.8 122		V dB
OPEN-LOOP GAIN, DC Open-Loop Voltage Gain	$R_L \geq 2k\Omega$	$113^{(3)}$	120		dB
RATED OUTPUT Voltage Output Short Circuit Current	$R_L = 2k\Omega$ $V_O = 0VDC$	$\pm 11.0^{(3)}$	± 13.4 25		V mA
TEMPERATURE RANGE Specification		-40		+85	$^{\circ}C$

NOTES: (1) Offset voltage specification are measured with automatic test equipment after approximately 0.5s from power turn-on. (2) Unnulled or nulled with 8k Ω to 20k Ω potentiometer. (3) This parameter specified by design.

TYPICAL CHARACTERISTICS

At $T_A = +25^\circ\text{C}$, $\pm V_{CC} = \pm 15\text{VDC}$, unless otherwise noted.

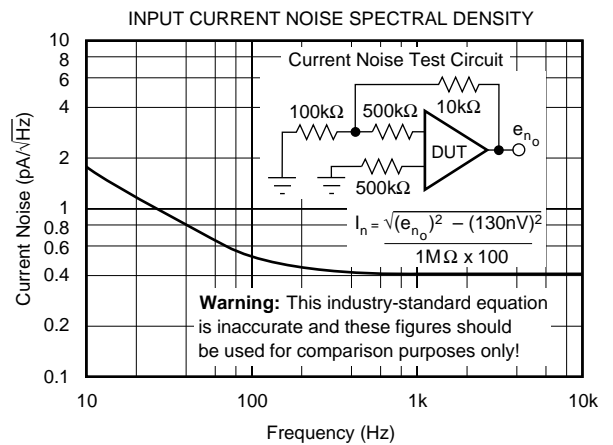
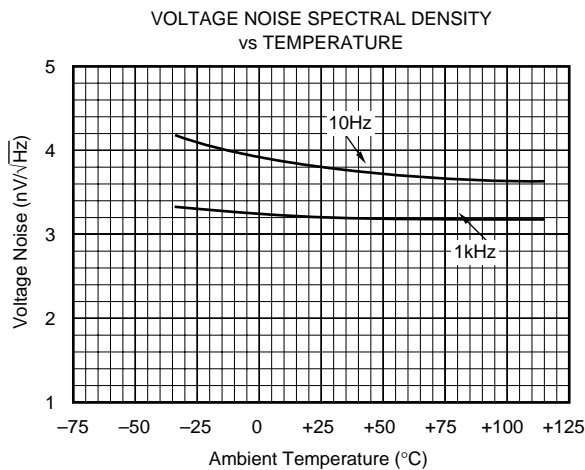
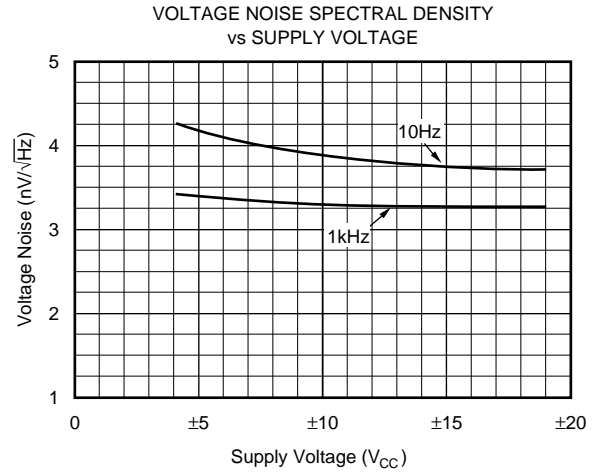
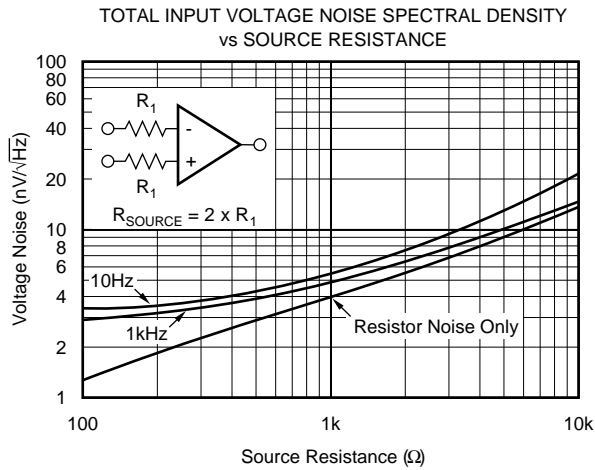
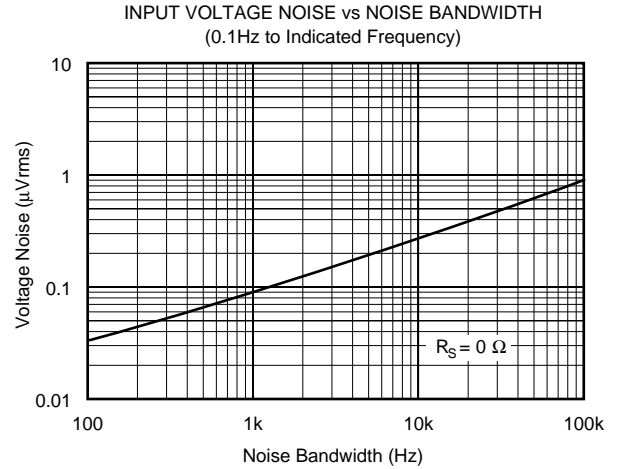
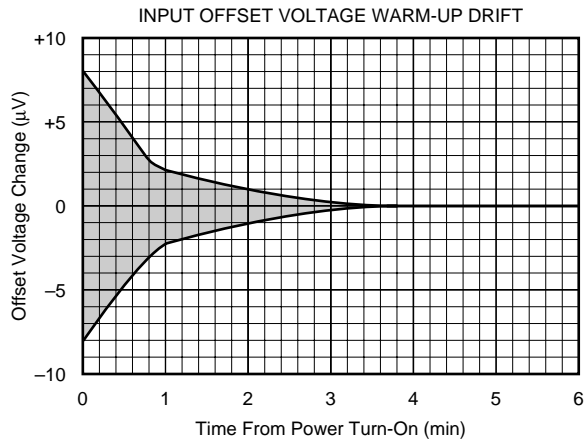

TYPICAL CHARACTERISTICS (Cont.)

At $T_A = +25^\circ\text{C}$, $\pm V_{CC} = \pm 15\text{VDC}$, unless otherwise noted.

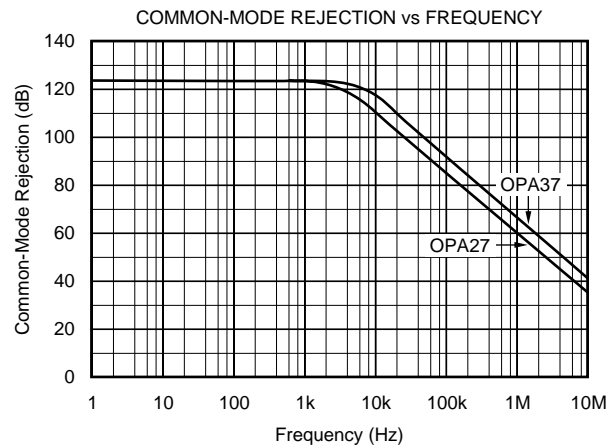
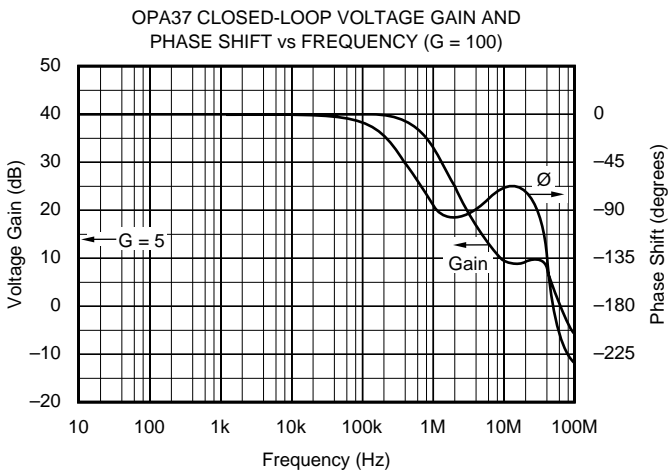
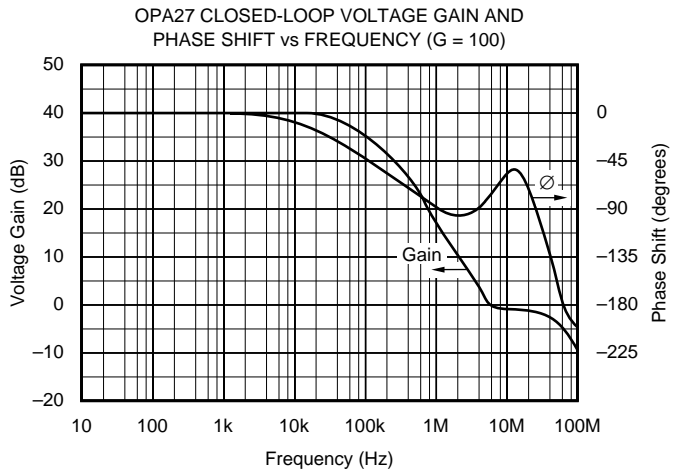
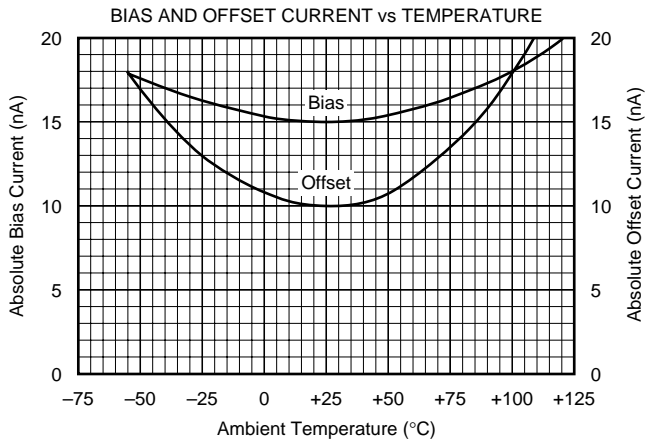
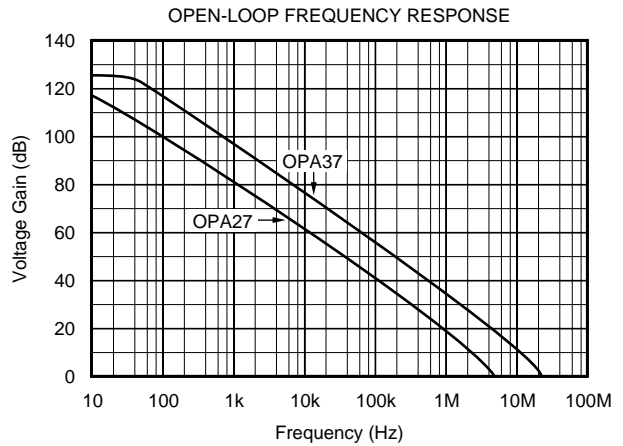
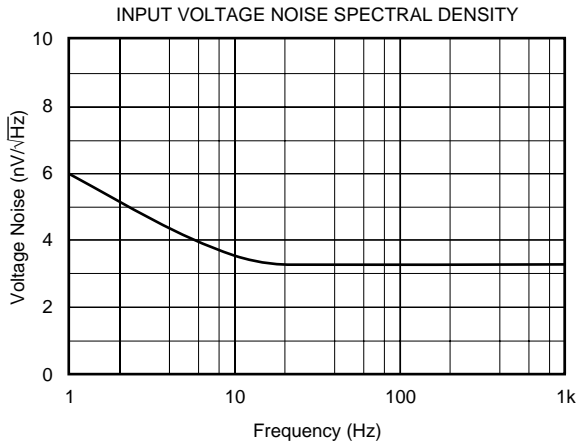

TYPICAL CHARACTERISTICS (Cont.)

At $T_A = +25^\circ\text{C}$, $\pm V_{CC} = \pm 15\text{VDC}$, unless otherwise noted.

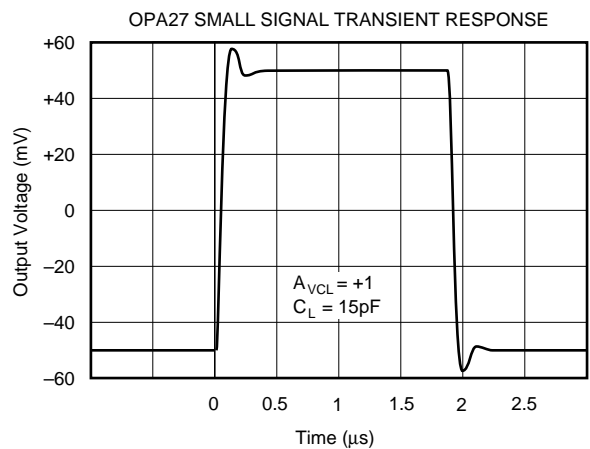
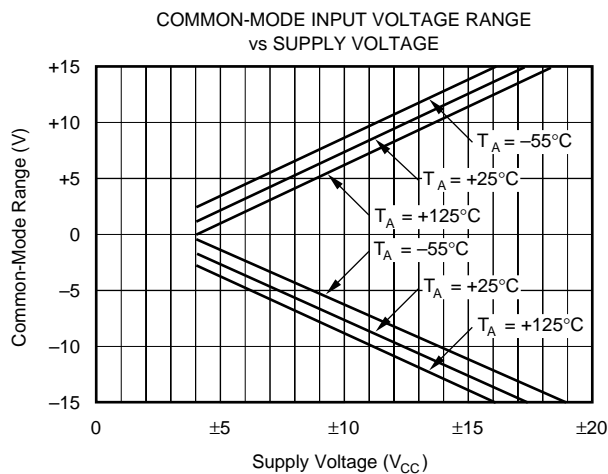
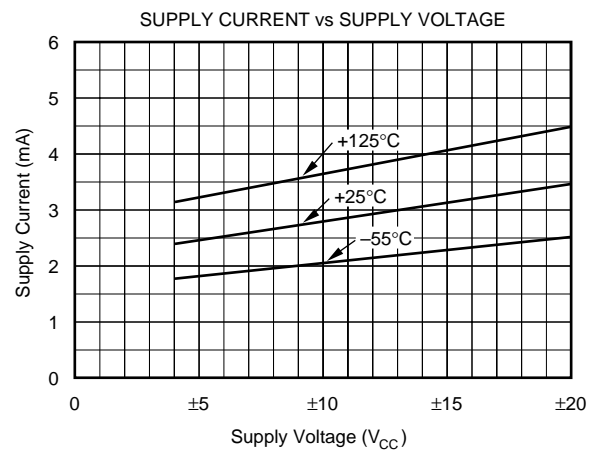
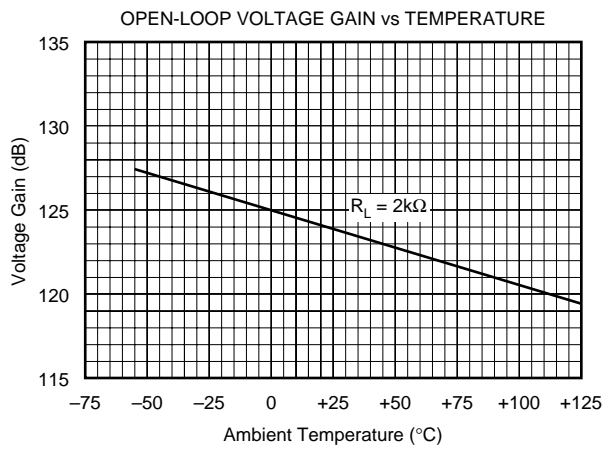
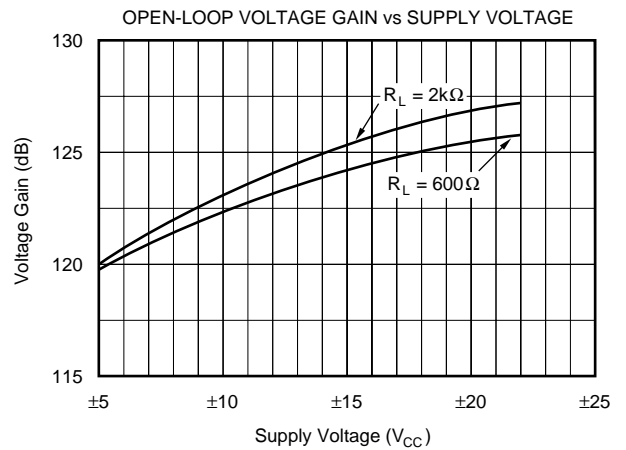
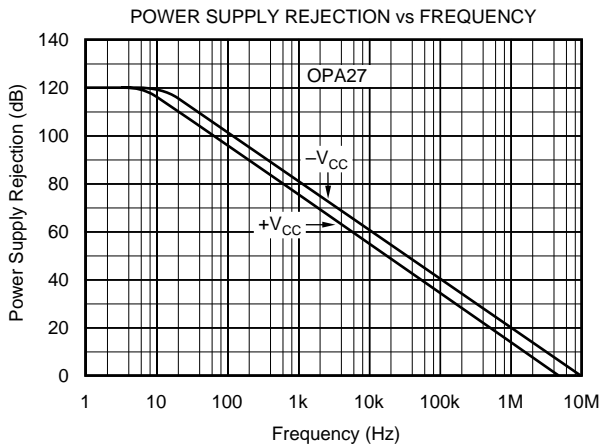

TYPICAL PERFORMANCE CURVES (Cont.)

At $T_A = +25^\circ\text{C}$, $\pm V_{CC} = \pm 15\text{VDC}$, unless otherwise noted.

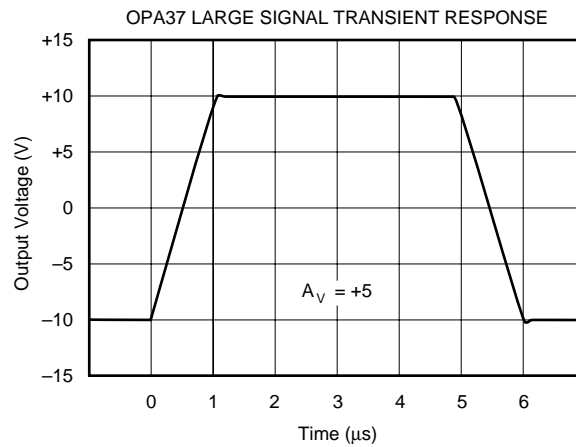
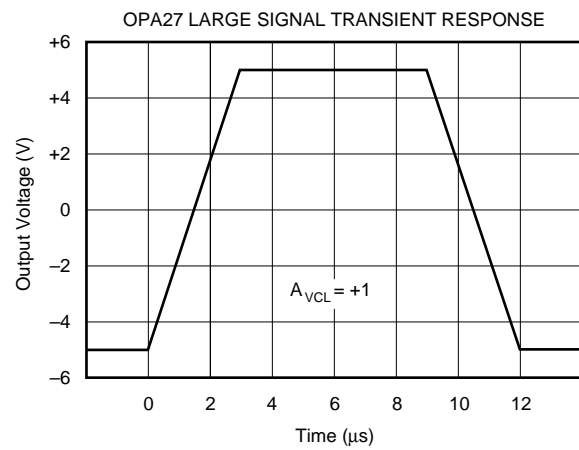
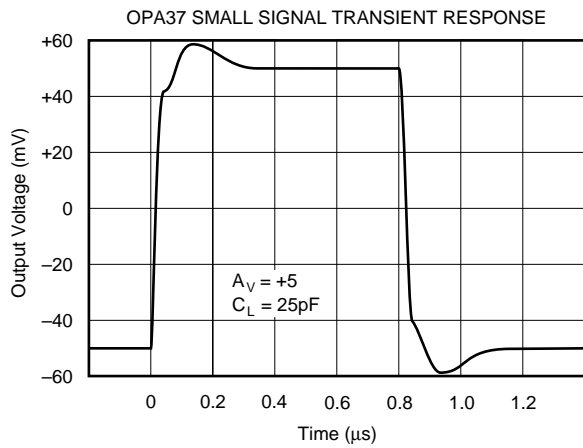

APPLICATIONS INFORMATION

OFFSET VOLTAGE ADJUSTMENT

The OPA27 and OPA37 offset voltages are laser-trimmed and require no further trim for most applications. Offset voltage drift will not be degraded when the input offset is nulled with a 10kΩ trim potentiometer. Other potentiometer values from 1kΩ to 1MΩ can be used, but V_{OS} drift will be degraded by an additional 0.1μV/°C to 0.2μV/°C. Nulling large system offsets by use of the offset trim adjust will degrade drift performance by approximately 3.3μV/°C per millivolt of offset. Large system offsets can be nulled without drift degradation by input summing.

The conventional offset voltage trim circuit is shown in Figure 3. For trimming very small offsets, the higher resolution circuit shown in Figure 4 is recommended.

The OPA27 and OPA37 can replace 741-type operational amplifiers by removing or modifying the trim circuit.

THERMOELECTRIC POTENTIALS

The OPA27 and OPA37 are laser-trimmed to microvolt-level input offset voltages, and for very-low input offset voltage drift.

Careful layout and circuit design techniques are necessary to prevent offset and drift errors from external thermoelectric potentials. Dissimilar metal junctions can generate small EMFs if care is not taken to eliminate either their sources (lead-to-PC, wiring, etc.) or their temperature difference (see Figure 11).

Short, direct mounting of the OPA27 and OPA37 with close spacing of the input pins is highly recommended. Poor layout can result in circuit drifts and offsets which are an order of magnitude greater than the operational amplifier alone.

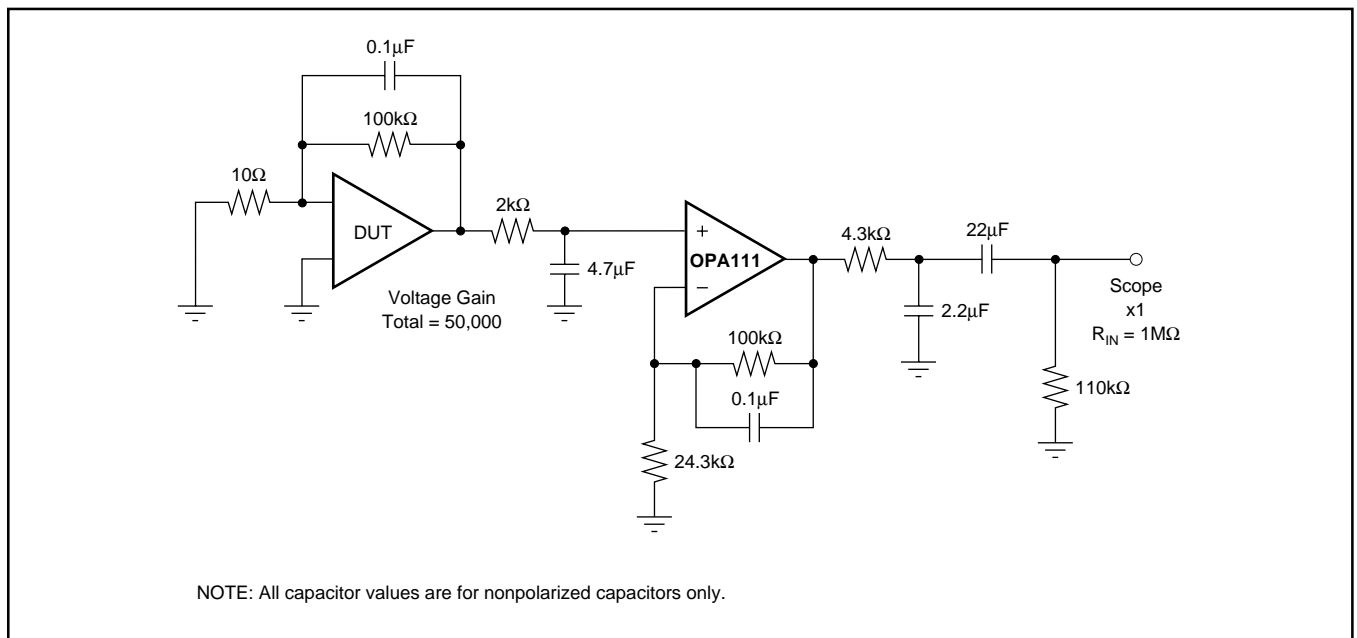

FIGURE 1. 0.1Hz to 10Hz Noise Test Circuit.

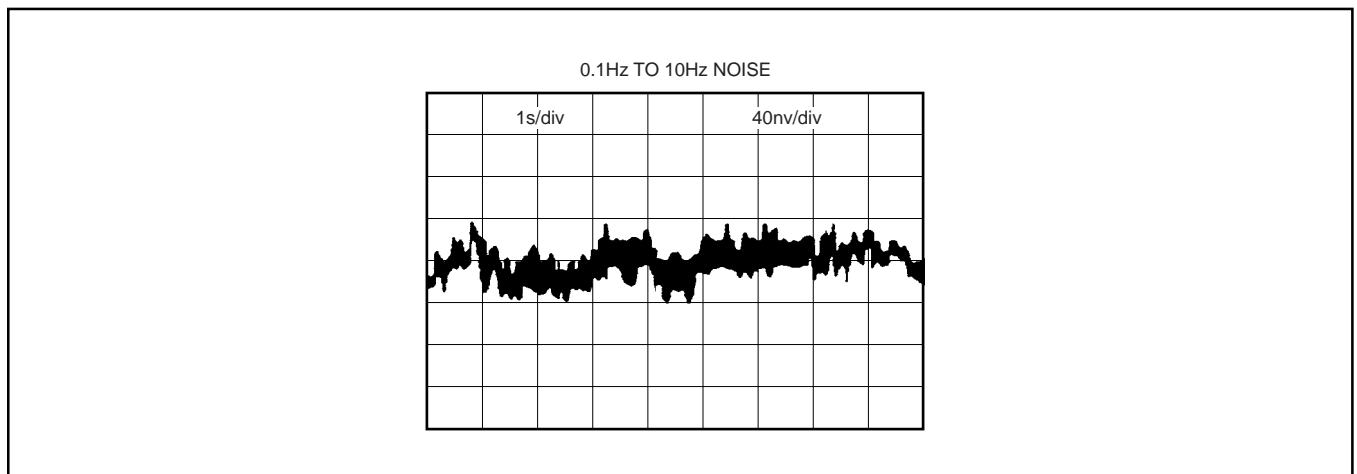

FIGURE 2. Low Frequency Noise.

NOISE: BIPOLAR VERSUS FET

Low-noise circuit design requires careful analysis of all noise sources. External noise sources can dominate in many cases, so consider the effect of source resistance on overall operational amplifier noise performance. At low source impedances, the lower voltage noise of a bipolar operational amplifier is superior, but at higher impedances the high current noise of a bipolar amplifier becomes a serious liability. Above about 15kΩ, the OPA111 low-noise FET operational amplifier is recommended for lower total noise than the OPA27, as shown in Figure 5.

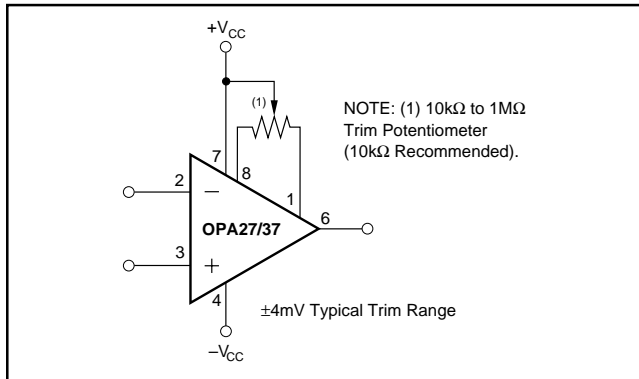

FIGURE 3. Offset Voltage Trim.

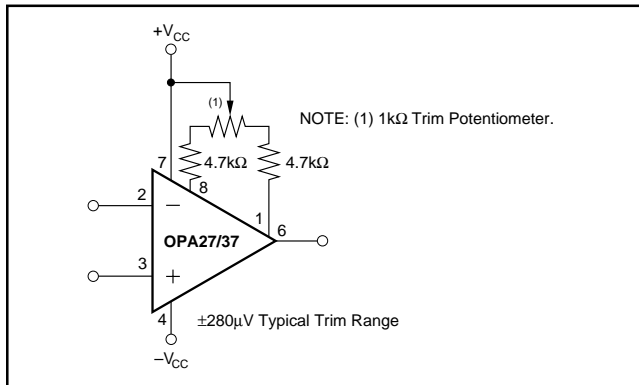

FIGURE 4. High Resolution Offset Voltage Trim.

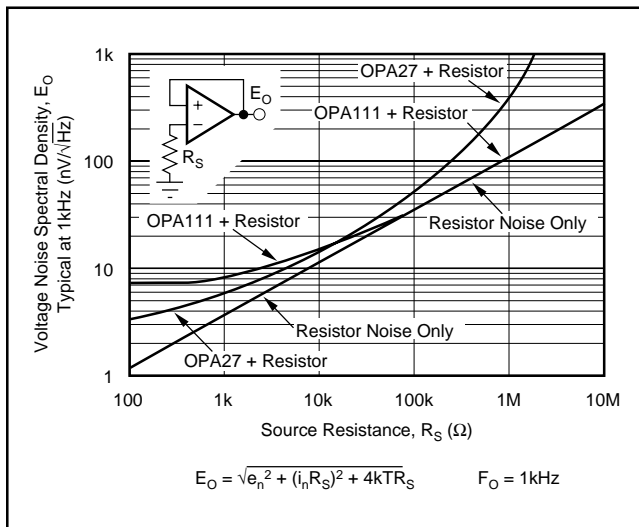

FIGURE 5. Voltage Noise Spectral Density Versus Source Resistance.

COMPENSATION

Although internally compensated for unity-gain stability, the OPA27 may require a small capacitor in parallel with a feedback resistor (R_F) which is greater than 2kΩ. This capacitor will compensate the pole generated by R_F and C_{IN} and eliminate peaking or oscillation.

INPUT PROTECTION

Back-to-back diodes are used for input protection on the OPA27 and OPA37. Exceeding a few hundred millivolts differential input signal will cause current to flow, and without external current limiting resistors, the input will be destroyed.

Accidental static discharge, as well as high current, can damage the amplifier's input circuit. Although the unit may still be functional, important parameters such as input offset voltage, drift, and noise may be permanently damaged, as will any precision operational amplifier subjected to this abuse.

Transient conditions can cause feedthrough due to the amplifier's finite slew rate. When using the OPA27 as a unity-gain buffer (follower) a feedback resistor of 1kΩ is recommended, as shown in Figure 6.

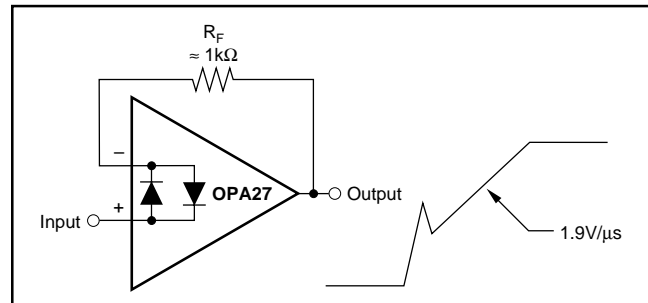

FIGURE 6. Pulsed Operation.

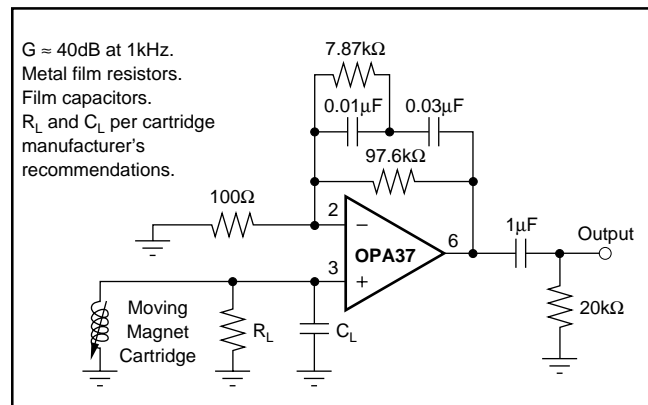

FIGURE 7. Low-Noise RIAA Preamplifier.

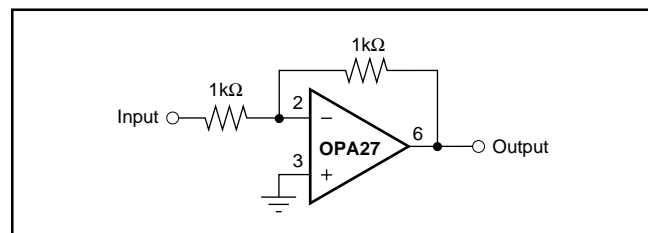

FIGURE 8. Unity-Gain Inverting Amplifier.

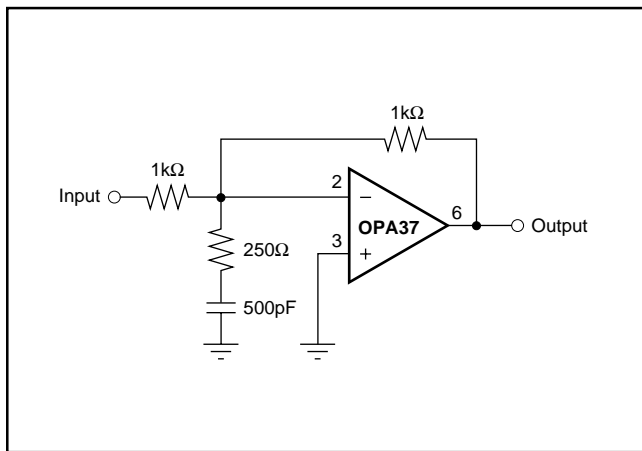

FIGURE 9. High Slew Rate Unity-Gain Inverting Amplifier.

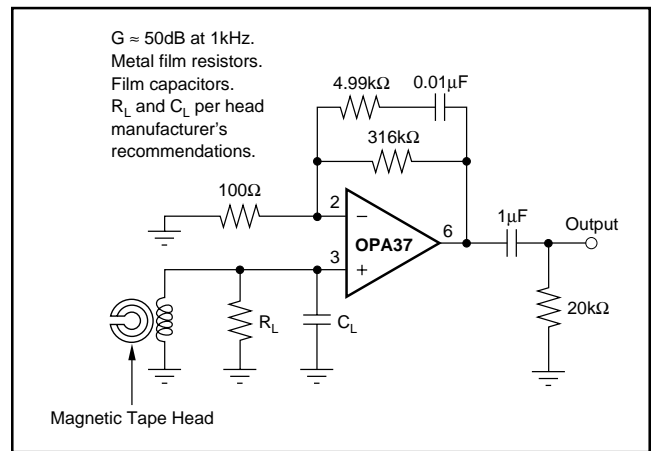

FIGURE 10. NAB Tape Head Preamp.

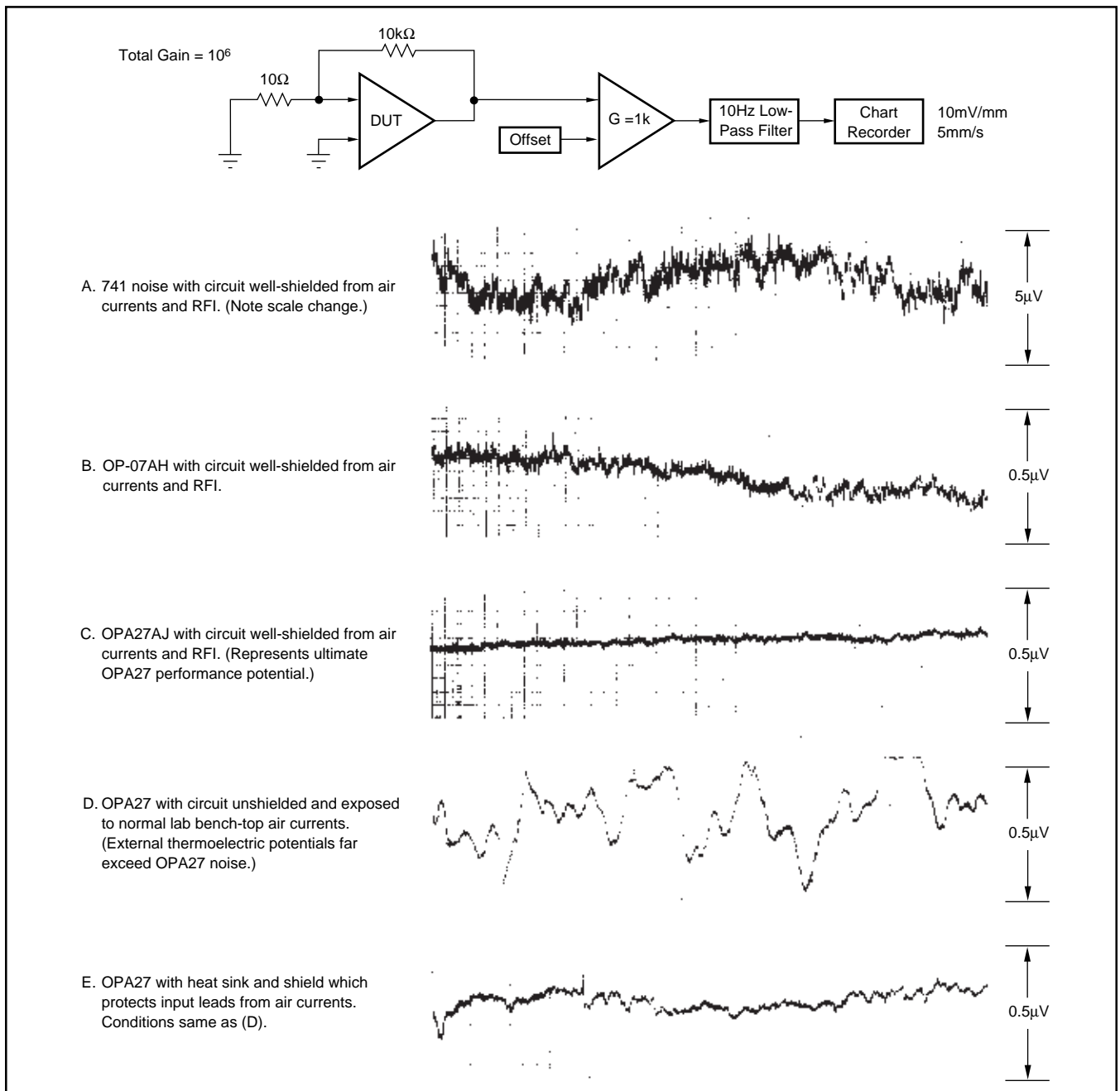

FIGURE 11. Low Frequency Noise Comparison.

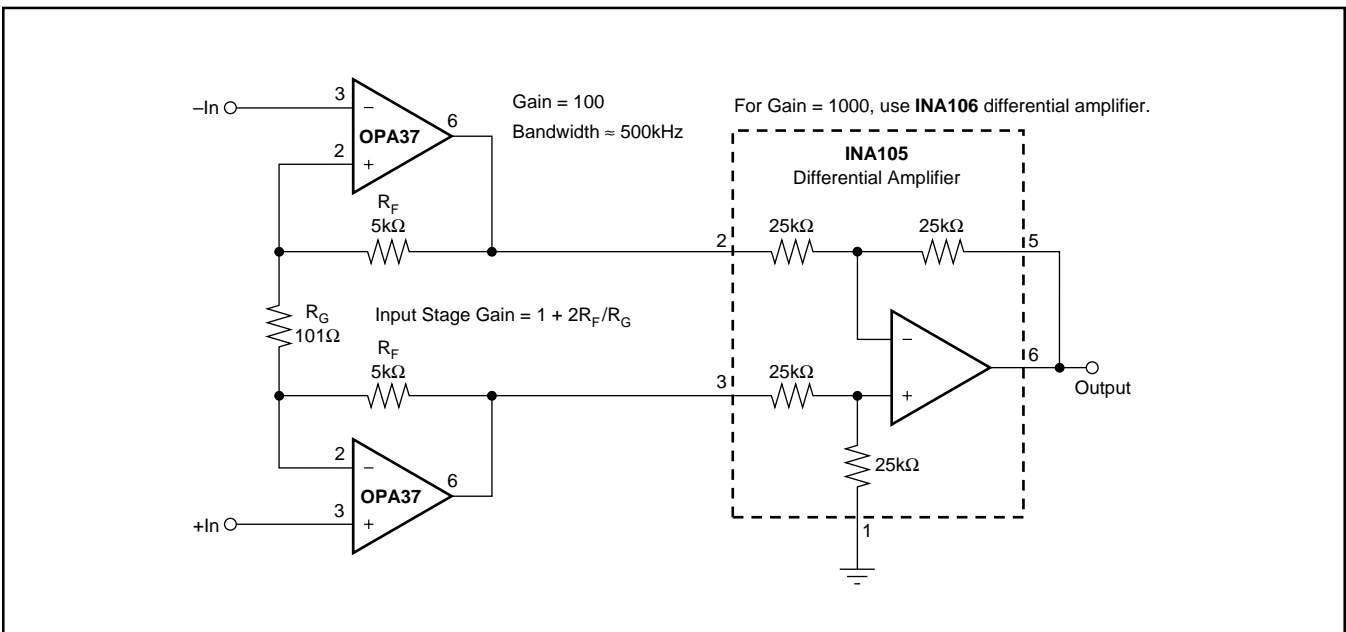

FIGURE 12. Low Noise Instrumentation Amplifier.

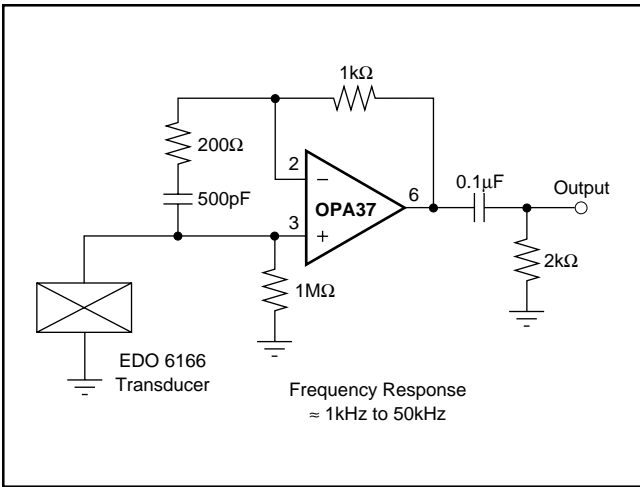

FIGURE 13. Hydrophone Preamplifier.

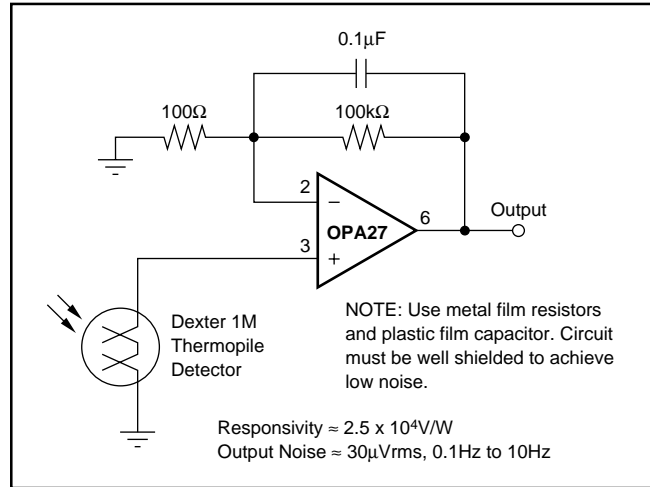

FIGURE 14. Long-Wavelength Infrared Detector Amplifier.

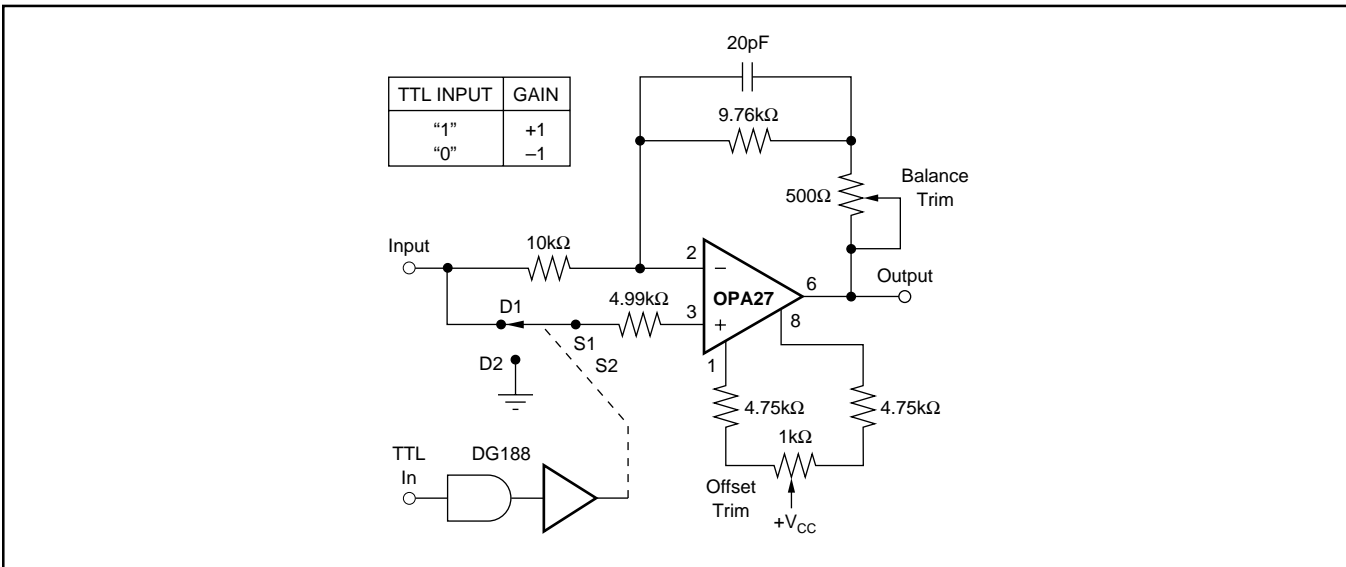

FIGURE 15. High Performance Synchronous Demodulator.

Gain = -1010V/V
 $V_{OS} \approx 2\mu\text{V}$
 Drift $\approx 0.07\mu\text{V}/^\circ\text{C}$
 $e_n \approx 1\text{nV}/\sqrt{\text{Hz}}$ at 10Hz
 $0.9\text{nV}/\sqrt{\text{Hz}}$ at 100Hz
 $0.87\text{nV}/\sqrt{\text{Hz}}$ at 1kHz
 Full Power Bandwidth $\approx 180\text{kHz}$
 Gain Bandwidth $\approx 500\text{MHz}$
 Equivalent Noise Resistance $\approx 50\Omega$

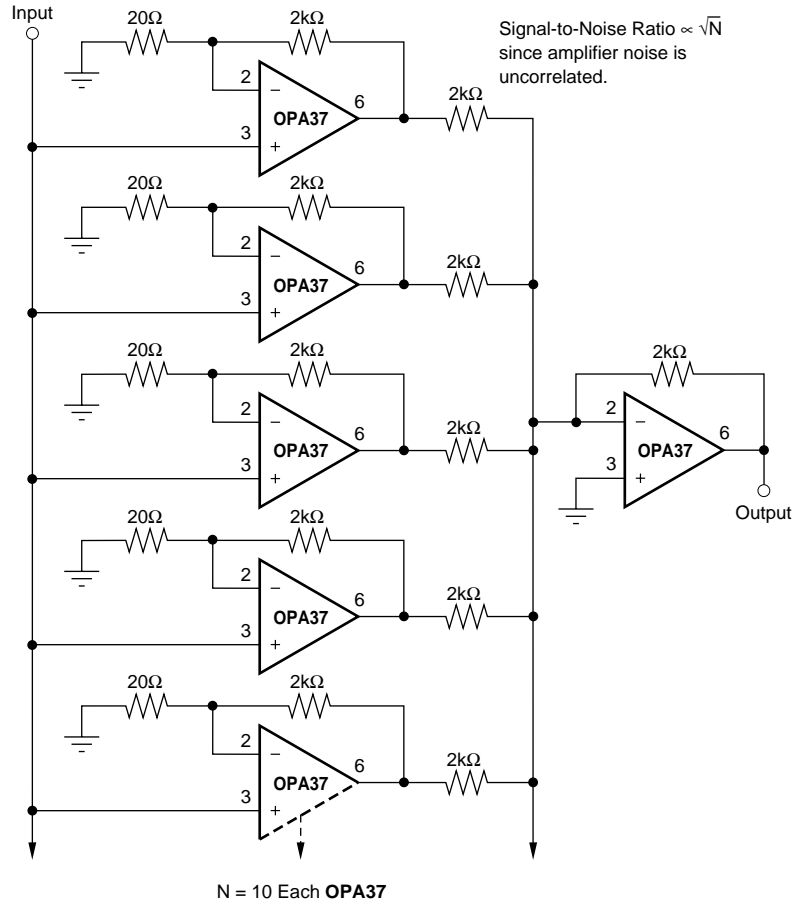

FIGURE 16. Ultra-Low Noise “N”-Stage Parallel Amplifier.

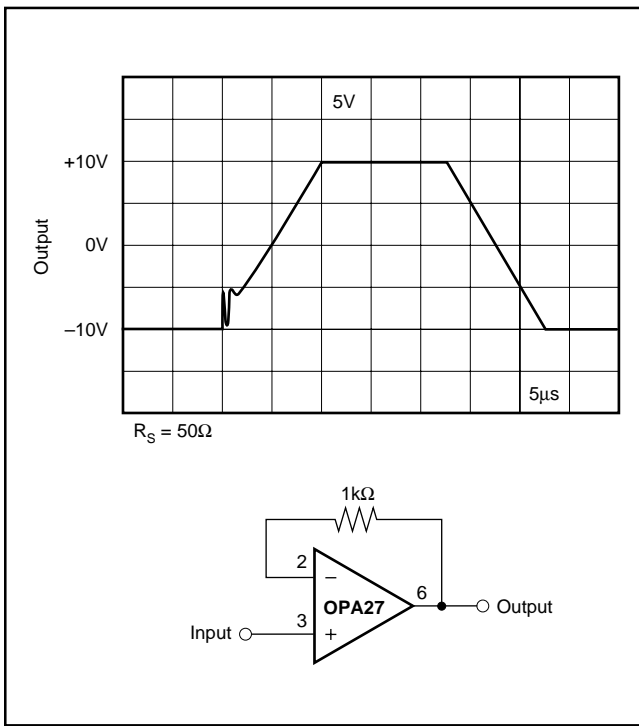

FIGURE 17. Unity-Gain Buffer.

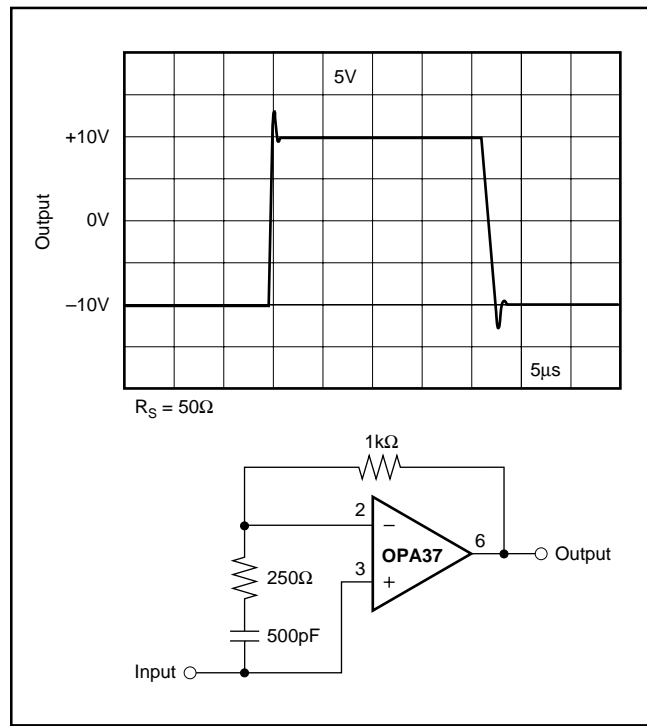

FIGURE 18. High Slew Rate Unity-Gain Buffer.

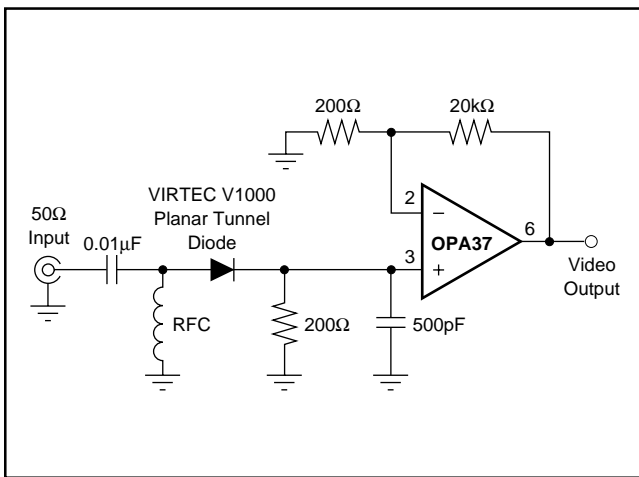

FIGURE 19. RF Detector and Video Amplifier.

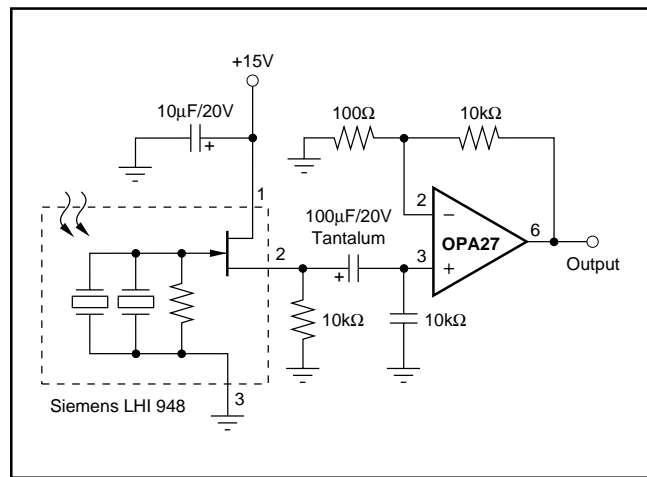

FIGURE 20. Balanced Pyroelectric Infrared Detector.

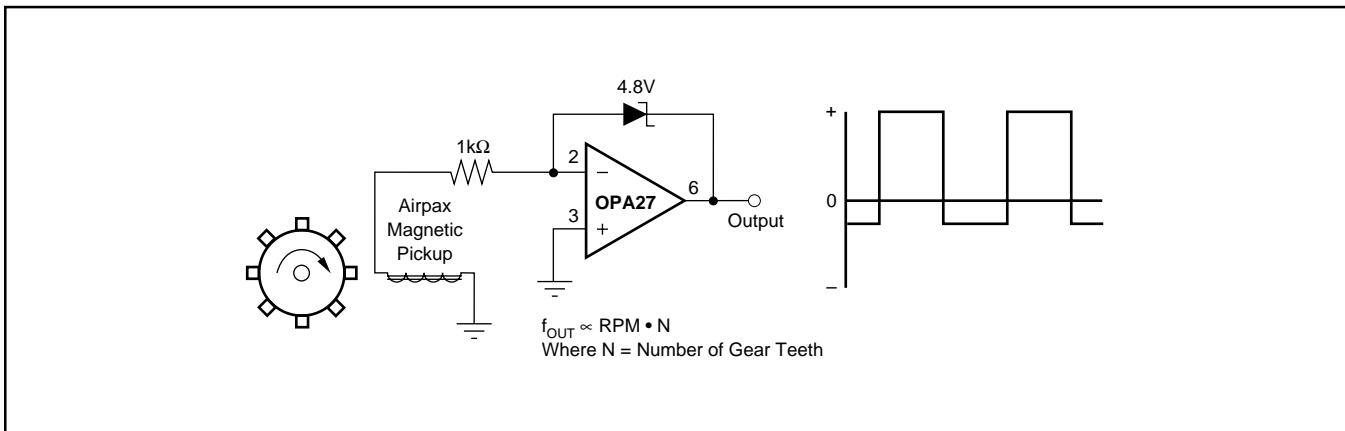

FIGURE 21. Magnetic Tachometer.

PACKAGING INFORMATION

Orderable Device	Status (1)	Package Type	Package Drawing	Pins	Package Qty	Eco Plan (2)	Lead/Ball Finish (6)	MSL Peak Temp (3)	Op Temp (°C)	Device Marking (4/5)	Samples
OPA27GP	ACTIVE	PDIP	P	8	50	Green (RoHS & no Sb/Br)	CU NIPDAU Call TI	N / A for Pkg Type	-40 to 85	OPA27GP	Samples
OPA27GU	ACTIVE	SOIC	D	8	75	Green (RoHS & no Sb/Br)	CU NIPDAU-DCC	Level-3-260C-168 HR	-40 to 85	OPA 27U	Samples
OPA27GU/2K5	ACTIVE	SOIC	D	8	2500	Green (RoHS & no Sb/Br)	CU NIPDAU-DCC	Level-3-260C-168 HR	-40 to 85	OPA 27U	Samples
OPA27GU/2K5E4	ACTIVE	SOIC	D	8	2500	Green (RoHS & no Sb/Br)	CU NIPDAU-DCC	Level-3-260C-168 HR	-40 to 85	OPA 27U	Samples
OPA27GUE4	ACTIVE	SOIC	D	8	75	Green (RoHS & no Sb/Br)	CU NIPDAU-DCC	Level-3-260C-168 HR	-40 to 85	OPA 27U	Samples
OPA27GUG4	ACTIVE	SOIC	D	8	75	Green (RoHS & no Sb/Br)	CU NIPDAU-DCC	Level-3-260C-168 HR	-40 to 85	OPA 27U	Samples
OPA37GP	ACTIVE	PDIP	P	8	50	Green (RoHS & no Sb/Br)	CU NIPDAU Call TI	N / A for Pkg Type	-40 to 85	OPA37GP	Samples
OPA37GPG4	ACTIVE	PDIP	P	8	50	Green (RoHS & no Sb/Br)	Call TI	N / A for Pkg Type	-40 to 85	OPA37GP	Samples
OPA37GU	ACTIVE	SOIC	D	8	75	Green (RoHS & no Sb/Br)	CU NIPDAU-DCC	Level-3-260C-168 HR	-40 to 85	OPA 37U	Samples
OPA37GU/2K5	ACTIVE	SOIC	D	8	2500	Green (RoHS & no Sb/Br)	CU NIPDAU-DCC	Level-3-260C-168 HR	-40 to 85	OPA 37U	Samples
OPA37GUE4	ACTIVE	SOIC	D	8	75	Green (RoHS & no Sb/Br)	CU NIPDAU-DCC	Level-3-260C-168 HR	-40 to 85	OPA 37U	Samples

(1) The marketing status values are defined as follows:

ACTIVE: Product device recommended for new designs.

LIFEBUY: TI has announced that the device will be discontinued, and a lifetime-buy period is in effect.

NRND: Not recommended for new designs. Device is in production to support existing customers, but TI does not recommend using this part in a new design.

PREVIEW: Device has been announced but is not in production. Samples may or may not be available.

OBSOLETE: TI has discontinued the production of the device.

(2) **RoHS:** TI defines "RoHS" to mean semiconductor products that are compliant with the current EU RoHS requirements for all 10 RoHS substances, including the requirement that RoHS substance do not exceed 0.1% by weight in homogeneous materials. Where designed to be soldered at high temperatures, "RoHS" products are suitable for use in specified lead-free processes. TI may reference these types of products as "Pb-Free".

RoHS Exempt: TI defines "RoHS Exempt" to mean products that contain lead but are compliant with EU RoHS pursuant to a specific EU RoHS exemption.

Green: TI defines "Green" to mean the content of Chlorine (Cl) and Bromine (Br) based flame retardants meet JS709B low halogen requirements of <=1000ppm threshold. Antimony trioxide based flame retardants must also meet the <=1000ppm threshold requirement.

- (3) MSL, Peak Temp. - The Moisture Sensitivity Level rating according to the JEDEC industry standard classifications, and peak solder temperature.
- (4) There may be additional marking, which relates to the logo, the lot trace code information, or the environmental category on the device.
- (5) Multiple Device Markings will be inside parentheses. Only one Device Marking contained in parentheses and separated by a "~" will appear on a device. If a line is indented then it is a continuation of the previous line and the two combined represent the entire Device Marking for that device.
- (6) Lead/Ball Finish - Orderable Devices may have multiple material finish options. Finish options are separated by a vertical ruled line. Lead/Ball Finish values may wrap to two lines if the finish value exceeds the maximum column width.

Important Information and Disclaimer:The information provided on this page represents TI's knowledge and belief as of the date that it is provided. TI bases its knowledge and belief on information provided by third parties, and makes no representation or warranty as to the accuracy of such information. Efforts are underway to better integrate information from third parties. TI has taken and continues to take reasonable steps to provide representative and accurate information but may not have conducted destructive testing or chemical analysis on incoming materials and chemicals. TI and TI suppliers consider certain information to be proprietary, and thus CAS numbers and other limited information may not be available for release.

In no event shall TI's liability arising out of such information exceed the total purchase price of the TI part(s) at issue in this document sold by TI to Customer on an annual basis.

TAPE AND REEL INFORMATION

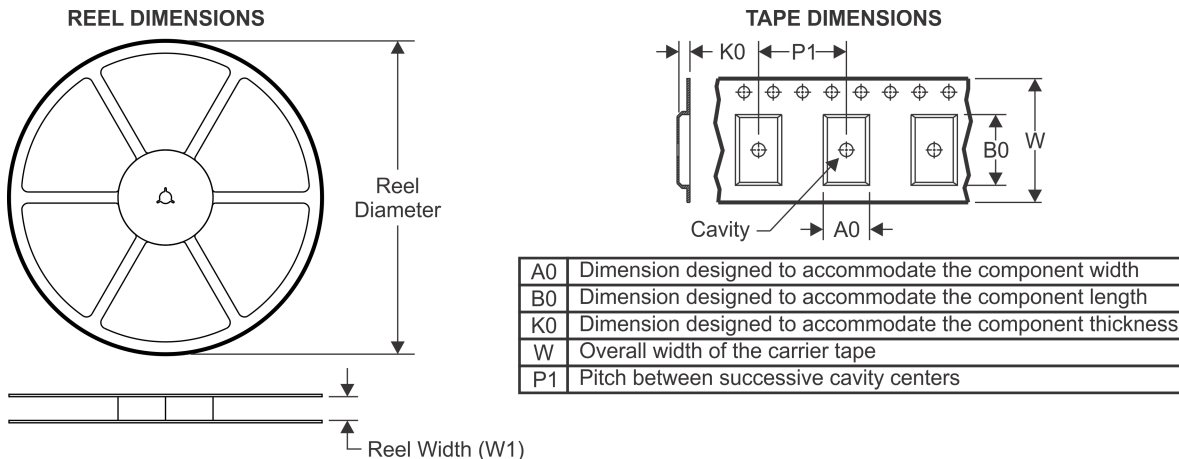

QUADRANT ASSIGNMENTS FOR PIN 1 ORIENTATION IN TAPE

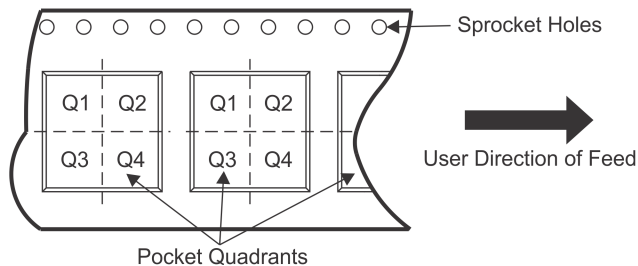

*All dimensions are nominal

Device	Package Type	Package Drawing	Pins	SPQ	Reel Diameter (mm)	Reel Width W1 (mm)	A0 (mm)	B0 (mm)	K0 (mm)	P1 (mm)	W (mm)	Pin1 Quadrant
OPA27GU/2K5	SOIC	D	8	2500	330.0	12.4	6.4	5.2	2.1	8.0	12.0	Q1
OPA37GU/2K5	SOIC	D	8	2500	330.0	12.4	6.4	5.2	2.1	8.0	12.0	Q1

TAPE AND REEL BOX DIMENSIONS

*All dimensions are nominal

Device	Package Type	Package Drawing	Pins	SPQ	Length (mm)	Width (mm)	Height (mm)
OPA27GU/2K5	SOIC	D	8	2500	367.0	367.0	35.0
OPA37GU/2K5	SOIC	D	8	2500	367.0	367.0	35.0



D0008A

PACKAGE OUTLINE

SOIC - 1.75 mm max height

SMALL OUTLINE INTEGRATED CIRCUIT



4214825/C 02/2019

NOTES:

- Linear dimensions are in inches [millimeters]. Dimensions in parenthesis are for reference only. Controlling dimensions are in inches. Dimensioning and tolerancing per ASME Y14.5M.
- This drawing is subject to change without notice.
- This dimension does not include mold flash, protrusions, or gate burrs. Mold flash, protrusions, or gate burrs shall not exceed $.006$ [0.15] per side.
- This dimension does not include interlead flash.
- Reference JEDEC registration MS-012, variation AA.

EXAMPLE STENCIL DESIGN

D0008A

SOIC - 1.75 mm max height

SMALL OUTLINE INTEGRATED CIRCUIT



SOLDER PASTE EXAMPLE
BASED ON .005 INCH [0.125 MM] THICK STENCIL
SCALE:8X

4214825/C 02/2019

NOTES: (continued)

8. Laser cutting apertures with trapezoidal walls and rounded corners may offer better paste release. IPC-7525 may have alternate design recommendations.
9. Board assembly site may have different recommendations for stencil design.

P (R-PDIP-T8)

PLASTIC DUAL-IN-LINE PACKAGE

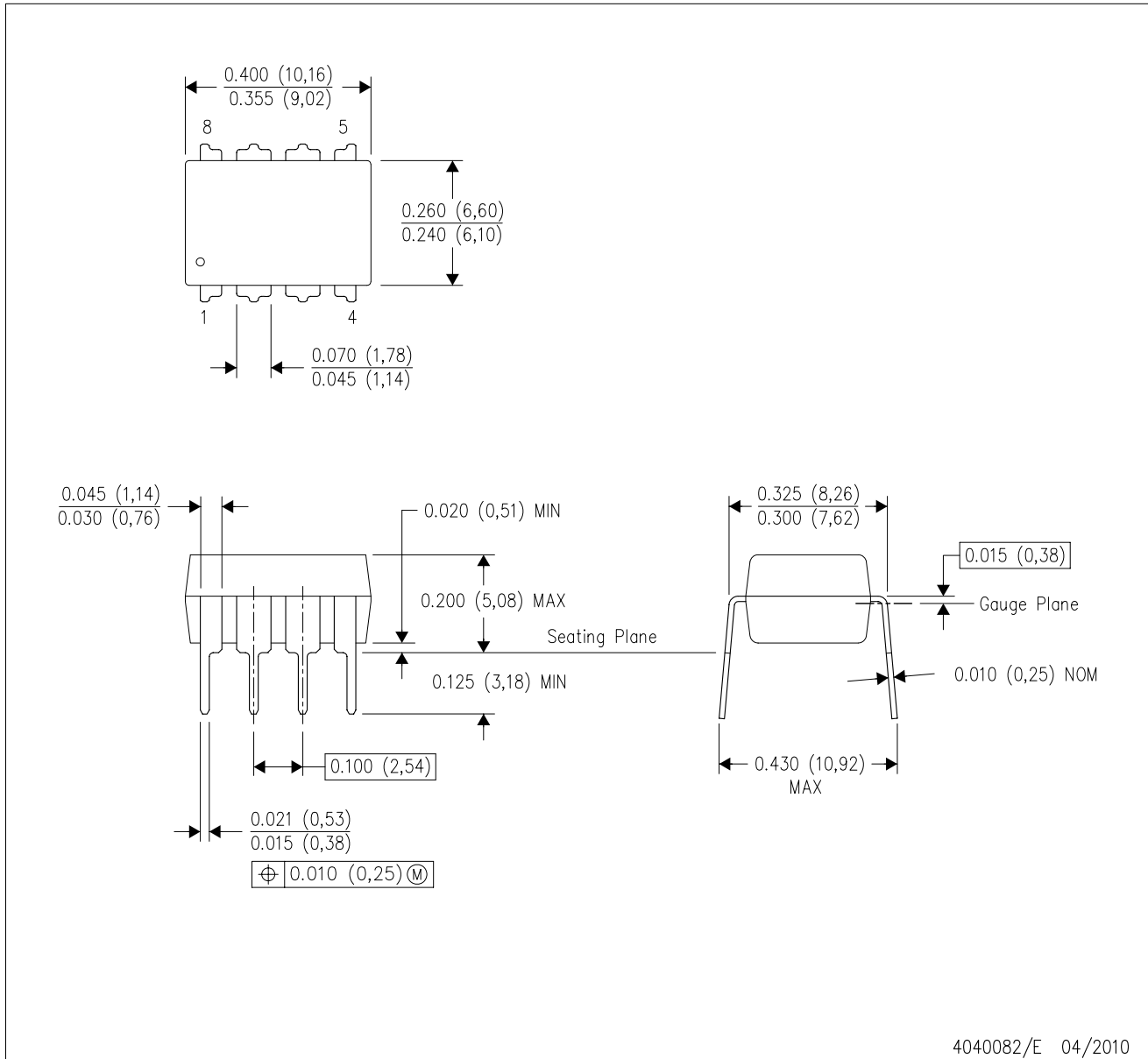

- NOTES:
- A. All linear dimensions are in inches (millimeters).
 - B. This drawing is subject to change without notice.
 - C. Falls within JEDEC MS-001 variation BA.

IMPORTANT NOTICE AND DISCLAIMER

TI PROVIDES TECHNICAL AND RELIABILITY DATA (INCLUDING DATASHEETS), DESIGN RESOURCES (INCLUDING REFERENCE DESIGNS), APPLICATION OR OTHER DESIGN ADVICE, WEB TOOLS, SAFETY INFORMATION, AND OTHER RESOURCES "AS IS" AND WITH ALL FAULTS, AND DISCLAIMS ALL WARRANTIES, EXPRESS AND IMPLIED, INCLUDING WITHOUT LIMITATION ANY IMPLIED WARRANTIES OF MERCHANTABILITY, FITNESS FOR A PARTICULAR PURPOSE OR NON-INFRINGEMENT OF THIRD PARTY INTELLECTUAL PROPERTY RIGHTS.

These resources are intended for skilled developers designing with TI products. You are solely responsible for (1) selecting the appropriate TI products for your application, (2) designing, validating and testing your application, and (3) ensuring your application meets applicable standards, and any other safety, security, or other requirements. These resources are subject to change without notice. TI grants you permission to use these resources only for development of an application that uses the TI products described in the resource. Other reproduction and display of these resources is prohibited. No license is granted to any other TI intellectual property right or to any third party intellectual property right. TI disclaims responsibility for, and you will fully indemnify TI and its representatives against, any claims, damages, costs, losses, and liabilities arising out of your use of these resources.

TI's products are provided subject to TI's Terms of Sale (www.ti.com/legal/termsofsale.html) or other applicable terms available either on ti.com or provided in conjunction with such TI products. TI's provision of these resources does not expand or otherwise alter TI's applicable warranties or warranty disclaimers for TI products.

Mailing Address: Texas Instruments, Post Office Box 655303, Dallas, Texas 75265
Copyright © 2019, Texas Instruments Incorporated

Looking for pricing, stock, or lifecycle information?

Click below to explore more details on WIN SOURCE:

 [View OPA27GPG4](#) on WIN SOURCE

 [Texas Instruments](#) Information

Optimize Your Supply Chain with WIN SOURCE Solutions

-  Global Sourcing Solution
-  Obsolete Management
-  Cost Control Management
-  Shortage Management
-  Alternative Solution
-  Excess Inventory Management