



**THE DATASHEET OF  
ONET1191PRGTR**



---

## 11.3-Gbps Limiting Amplifier

---

### FEATURES

- Up to 11.3-Gbps Operation
- Loss-of-Signal Detection (LOS)
- Adjustable Output Voltage
- Low Power Consumption
- Input Offset Cancellation
- CML Data Outputs With On-Chip, 50- $\Omega$  Back-Termination to VCC
- Single 3.3 V Supply
- Surface-Mount, Small-Footprint, 3-mm  $\times$  3-mm, 16-Pin QFN Package

### APPLICATIONS

- 10 Gigabit Ethernet Optical Transmitters
- 8 $\times$  and 10 $\times$  Fibre Channel Optical Transmitters
- SONET OC-192/SDH-64 Optical Transmitters
- XFP and SFP+ Transceiver Modules
- XENPAK, XPAK, X2 and 300-Pin MSA Transponder Modules
- Cable Driver and Receiver

### DESCRIPTION

The ONET1191P is a high-speed, 3.3-V limiting amplifier for copper-cable and fiber-optic applications with data rates up to 11.3 Gbps.

This device provides a gain of about 40 dB which ensures a fully differential output swing for input signals as low as 5 mV<sub>pp</sub>. The output amplitude can be adjusted from 400 mV<sub>pp</sub> to 700 mV<sub>pp</sub>. Loss-of-signal detection and output disable are also provided.

The part is available in a small-footprint, 3-mm  $\times$  3-mm, 16-pin QFN package, typically dissipates less than 110 mW, and is characterized for operation from  $-40^{\circ}\text{C}$  to  $85^{\circ}\text{C}$ .



Please be aware that an important notice concerning availability, standard warranty, and use in critical applications of Texas Instruments semiconductor products and disclaimers thereto appears at the end of this data sheet.

## BLOCK DIAGRAM

A simplified block diagram of the ONET1191P is shown in Figure 1.

This compact, low-power, 11.3-Gbps limiting amplifier consists of a high-speed data path with offset cancellation (dc feedback), a loss-of-signal detection block using two peak detectors, and a band-gap voltage reference and bias current generation block.

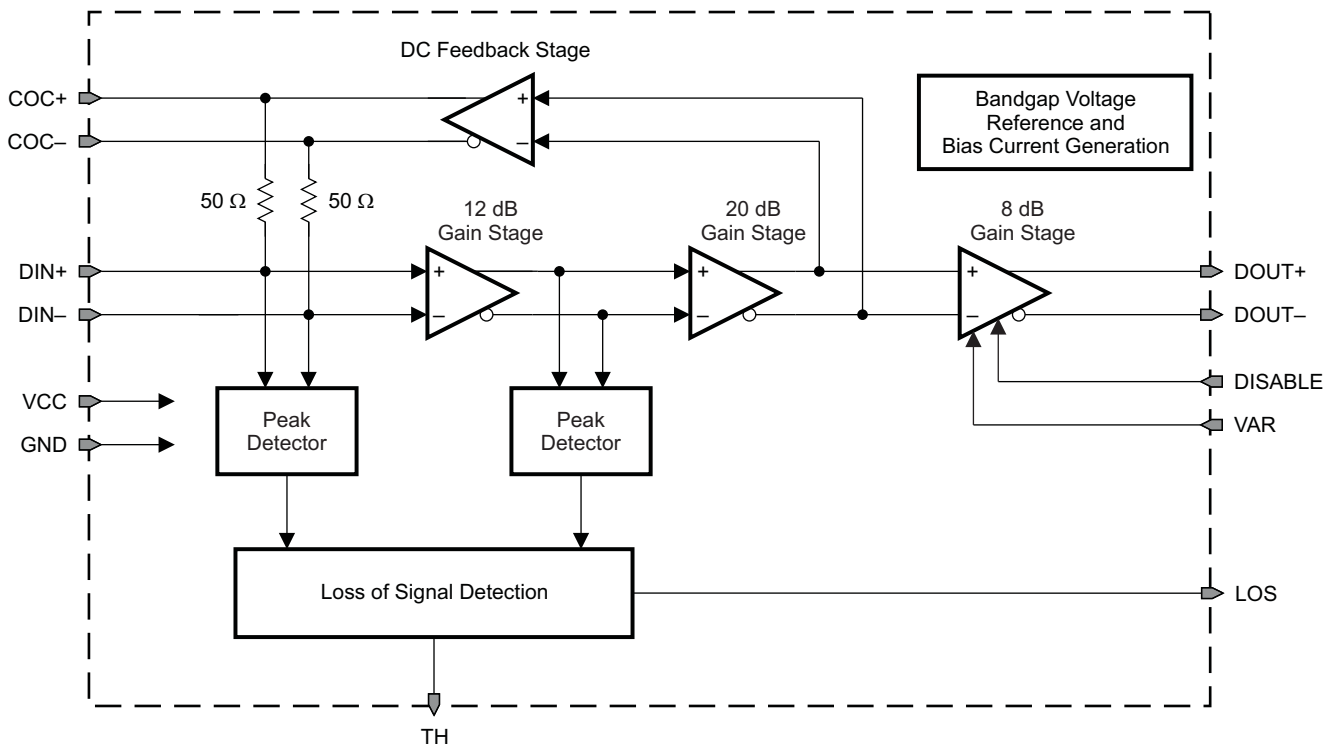

B0067-02

Figure 1. Simplified Block Diagram of the ONET1191P

## HIGH-SPEED DATA PATH

The high-speed data signal is applied to the data path by means of the input signal pins, DIN+/DIN-. The data path consists of a 12-dB input gain stage with  $2 \times 50\text{-}\Omega$  on-chip line-termination resistors, a second gain stage with 20 dB of gain, and a variable-gain output stage which provides another 8 dB of gain. The amplified data output signal is available at the output pins DOUT+/DOUT-, which include on-chip  $2 \times 50\text{-}\Omega$  back-termination to VCC. The output amplitude can be adjusted between  $400\text{ mV}_{pp}$  and  $700\text{ mV}_{pp}$  by connecting an external resistor between the VAR pin and ground (GND).

A dc feedback stage compensates for internal offset voltages and thus ensures proper operation even for very small input data signals. This stage is driven by the output signal of the second gain stage. The signal is low-pass filtered, amplified, and fed back to the input of the first gain stage via the on-chip,  $50\text{-}\Omega$  termination resistors. The required low-frequency cutoff is determined by an external  $0.1\text{ }\mu\text{F}$  capacitor, which must be differentially connected to the COC+/COC- pins.

## LOSS-OF-SIGNAL DETECTION

The peak values of the input signal and output signal of the first gain stage are monitored by two peak detectors. The peak values are compared to a predefined loss-of-signal threshold voltage inside the loss-of-signal detection block. As a result of the comparison, the LOS signal, which indicates that the input signal amplitude is below the defined threshold level, is generated.

The threshold voltage can be set within a certain range by means of an external resistor connected between the TH pin and ground.

## BAND-GAP VOLTAGE AND BIAS GENERATION

The ONET1191P limiting amplifier is supplied by a single 3.3-V supply voltage connected to the VCC pins. This voltage is referred to ground (GND).

On-chip band-gap voltage circuitry generates a reference voltage, independent of supply voltage, from which all other internally required voltages and bias currents are derived.

## PACKAGE

For the ONET1191P, a small-footprint, 3-mm × 3-mm, 16-pin QFN package, with a lead pitch of 0,5 mm, is used. The pinout is shown in [Figure 2](#).

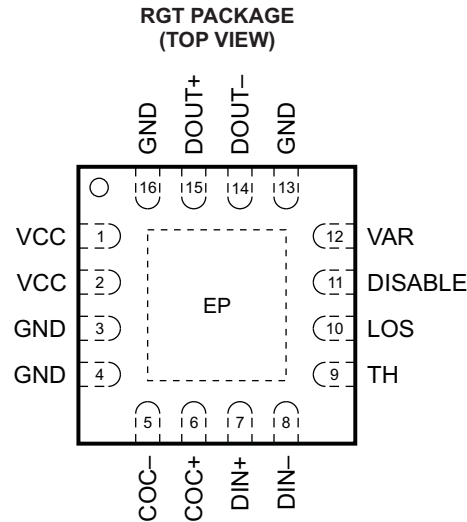

P0019-05

**Figure 2. Pinout of ONET1191P in a 3-mm × 3-mm, 16-Pin QFN Package**

## TERMINAL FUNCTIONS

TERMINAL		TYPE	DESCRIPTION
NAME	NO.		
COC+	6	Analog	Offset cancellation filter capacitor plus terminal. An external 0.1 μF filter capacitor must be connected between this pin and COC– (pin 5).
COC–	5	Analog	Offset cancellation filter capacitor minus terminal. An external 0.1 μF filter capacitor must be connected between this pin and COC+ (pin 6).
DIN+	7	Analog input	Noninverted data input. On-chip, 50-Ω terminated to COC+. Differentially 100-Ω terminated to DIN–.
DIN–	8	Analog input	Inverted data input. On-chip, 50-Ω terminated to COC–. Differentially 100-Ω terminated to DIN+.
DISABLE	11	CMOS input	Disables the output stage when set to a high level
DOU+	15	CML out	Noninverted data output. On-chip, 50-Ω back-terminated to VCC.
DOU–	14	CML out	Inverted data output. On-chip, 50-Ω back-terminated to VCC.
GND	3, 4, 13, 16, EP	Supply	Circuit ground. Exposed die pad (EP) must be grounded.
LOS	10	Open-drain MOS	High level indicates that the input signal amplitude is below the programmed threshold level. Open-drain output. Requires an external 10-kΩ pullup resistor to VCC for proper operation.
TH	9	Analog input	LOS threshold adjustment with resistor to GND
VAR	12	Analog input	Variable output amplitude control. Output amplitude can be reduced to 400 mV <sub>pp</sub> by grounding the VAR pin. Output amplitude can be set from 400 mV <sub>pp</sub> to 700 mV <sub>pp</sub> by connecting a 0 to 100-kΩ resistor to GND or leaving the pin open.
VCC	1, 2	Supply	3.3-V ±10% supply voltage

## ABSOLUTE MAXIMUM RATINGS

over operating free-air temperature range (unless otherwise noted)<sup>(1)</sup>

		VALUE	UNIT
$V_{CC}$	Supply voltage <sup>(2)</sup>	–0.3 to 4	V
$V_{DIN+}$ , $V_{DIN-}$	Voltage at DIN+, DIN– <sup>(2)</sup>	0.5 to 4	V
$V_{LOS}$ , $V_{COC+}$ , $V_{COC-}$ , $V_{TH}$ , $V_{DOUT+}$ , $V_{DOUT-}$	Voltage at LOS, COC+, COC–, TH, DOUT+, DOUT– <sup>(2)</sup>	–0.3 to 4	V
$V_{DIN,DIFF}$	Differential voltage between DIN+ and DIN–	±1.25	V
$I_{LOS}$	Current into LOS	1	mA
$I_{DIN+}$ , $I_{DIN-}$ , $I_{DOUT+}$ , $I_{DOUT-}$	Continuous current at inputs and outputs	20	mA
ESD	ESD rating at all pins	1.5	kV (HBM)
$T_{J,max}$	Maximum junction temperature	125	°C
$T_{STG}$	Storage temperature range	–65 to 85	°C
$T_A$	Characterized free-air operating temperature range	–40 to 85	°C
$T_{LEAD}$	Lead temperature 1,6 mm (1/16 inch) from case for 10 seconds	260	°C

- (1) Stresses beyond those listed under *absolute maximum ratings* may cause permanent damage to the device. These are stress ratings only, and functional operation of the device at these or any other conditions beyond those indicated under *recommended operating conditions* is not implied. Exposure to absolute-maximum-rated conditions for extended periods may affect device reliability.
- (2) All voltage values are with respect to network ground terminal.

## RECOMMENDED OPERATING CONDITIONS

		MIN	TYP	MAX	UNIT
$V_{CC}$	Supply voltage	2.9	3.3	3.6	V
$T_A$	Operating free-air temperature	–40		85	°C
	Disable input high voltage	2			V
	Disable input low voltage			0.25	V
	Optimum LOS threshold resistor	32		62	k $\Omega$
	$R_{VAR}$ range	0		open	k $\Omega$

## DC ELECTRICAL CHARACTERISTICS

over recommended operating conditions, outputs connected to a 50- $\Omega$  load,  $R_{VAR}$  = open (unless otherwise noted)

PARAMETER	TEST CONDITIONS	MIN	TYP	MAX	UNIT
$V_{CC}$	Supply voltage	2.9	3.3	3.6	V
$I_{VCC}$	Supply current		33	49	mA
$R_{IN}$	Data input resistance		50		$\Omega$
$R_{OUT}$	Data output resistance		50		$\Omega$
	Voltage at TH pin		1.25		V
	LOS HIGH voltage	10-k $\Omega$ pullup to $V_{CC}$ , $I_{SOURCE} = 50 \mu A$	2.4		
	LOS LOW voltage	10-k $\Omega$ pullup to $V_{CC}$ , $I_{SINK} = 200 \mu A$		0.5	V

## AC ELECTRICAL CHARACTERISTICS

over recommended operating conditions, outputs connected to a 50-Ω load,  $R_{VAR}$  = open (unless otherwise noted). Typical operating condition is at  $V_{CC}$  = 3.3 V and  $T_A$  = 25°C.

PARAMETER		TEST CONDITIONS	MIN	TYP	MAX	UNIT
$f_{3dB-H}$	High-frequency –3-dB bandwidth		8	11	15	GHz
$f_{3dB-L}$	Low-frequency –3-dB bandwidth	$C_{OC} = 0.1 \mu F$ , ac coupling capacitors = 0.1 $\mu F$		30		kHz
$V_{IN,MIN}$	Data input sensitivity	K28.5 at 11.3 Gbps, BER < 10 <sup>-12</sup>		2.5	5	mV <sub>pp</sub>
		$V_{OD-min} \geq 0.95 \times V_{OD}$ (output limited)		10	20	
A	Small-signal gain		34	40	44	dB
$V_{IN,MAX}$	Data input overload		2000			mV <sub>pp</sub>
DJ	Deterministic jitter	$V_{IN} = 5 \text{ mV}_{pp}$ , K28.5 at 11.3 Gbps		4	7	ps <sub>pp</sub>
		$V_{IN} = 20 \text{ mV}_{pp}$ , K28.5 at 11.3 Gbps		4	9	
RJ	Random jitter	Input = 5 mV <sub>pp</sub>		1.6		ps <sub>RMS</sub>
		Input = 20 mV <sub>pp</sub>		0.7		
$V_{OD}$	Differential data output voltage	$V_{IN} \geq 20 \text{ mV}_{pp}$ , DISABLE = LOW	600	700	900	mV <sub>pp</sub>
		DISABLE = HIGH		25	100	
$t_r$	Output rise time	20% to 80%, $V_{IN} \geq 20 \text{ mV}_{pp}$		25	35	ps
$t_f$	Output fall time	20% to 80%, $V_{IN} \geq 20 \text{ mV}_{pp}$		25	35	ps
$V_{TH}$	LOS assert threshold range	K28.5 pattern at 10.7 Gbps, $R_{TH} = 62 \text{ k}\Omega$		40		mV <sub>pp</sub>
		K28.5 pattern at 10.7 Gbps, $R_{TH} = 32 \text{ k}\Omega$		65		
	LOS threshold variation	Versus temperature		3		dB
		Versus supply voltage $V_{CC}$		1		dB
	LOS hysteresis	K28.5 pattern at 11.3 Gbps	1.5		7	dB
$t_{LOS\_AST}$	LOS assert time			1300	2000	ns
$t_{LOS\_DEA}$	LOS deassert time			120		ns
$t_{DIS}$	Disable response time			90		ns

**TYPICAL OPERATION CHARACTERISTICS**

Typical operating condition is at  $V_{CC} = 3.3\text{ V}$ ,  $T_A = 25^\circ\text{C}$ , and  $R_{VAR} = \text{open}$  (unless otherwise noted)

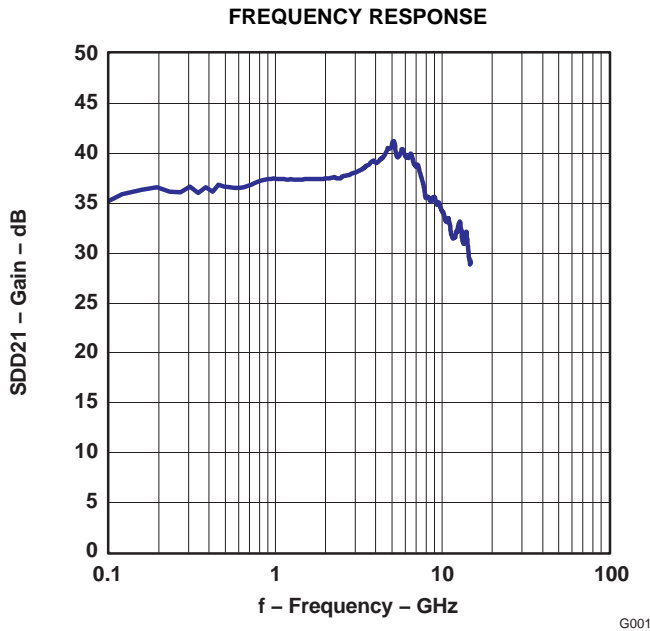

Figure 3.

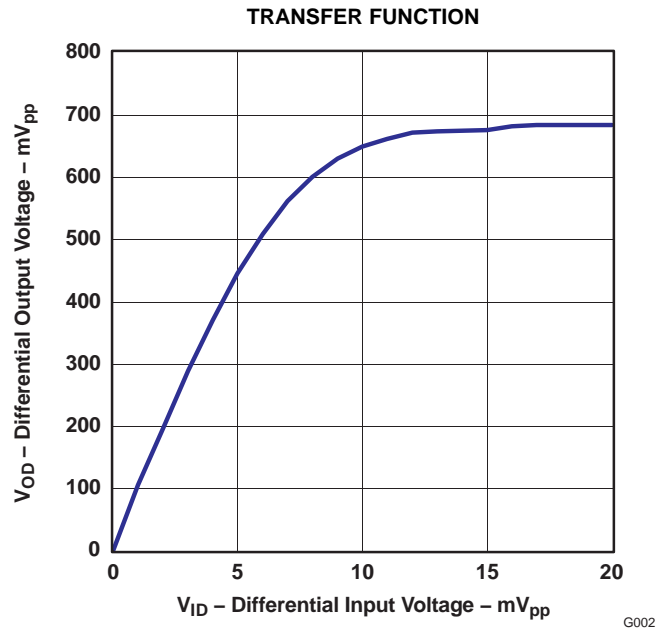

Figure 4.

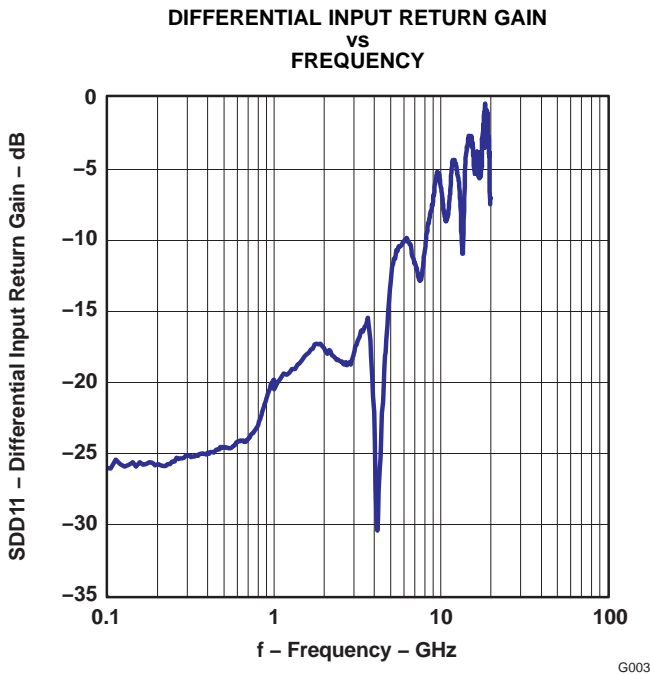

Figure 5.

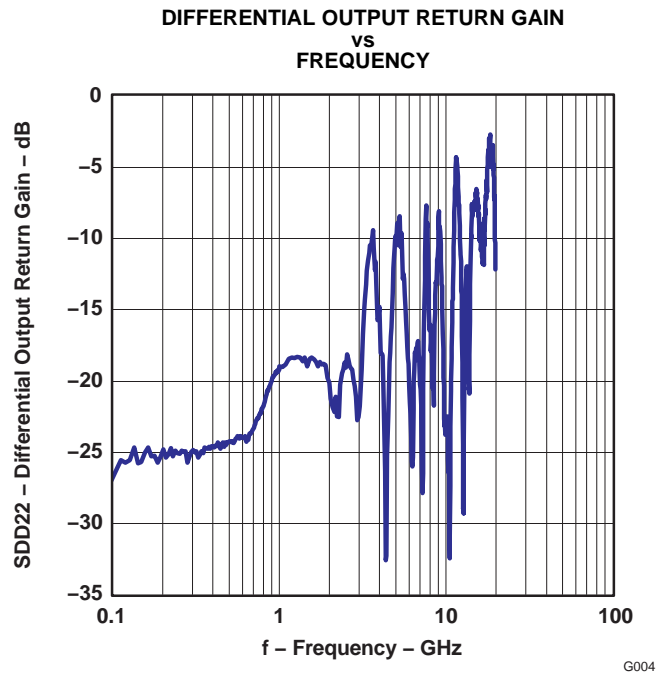

Figure 6.

TYPICAL OPERATION CHARACTERISTICS (continued)

Typical operating condition is at  $V_{CC} = 3.3\text{ V}$ ,  $T_A = 25^\circ\text{C}$ , and  $R_{VAR} = \text{open}$  (unless otherwise noted)

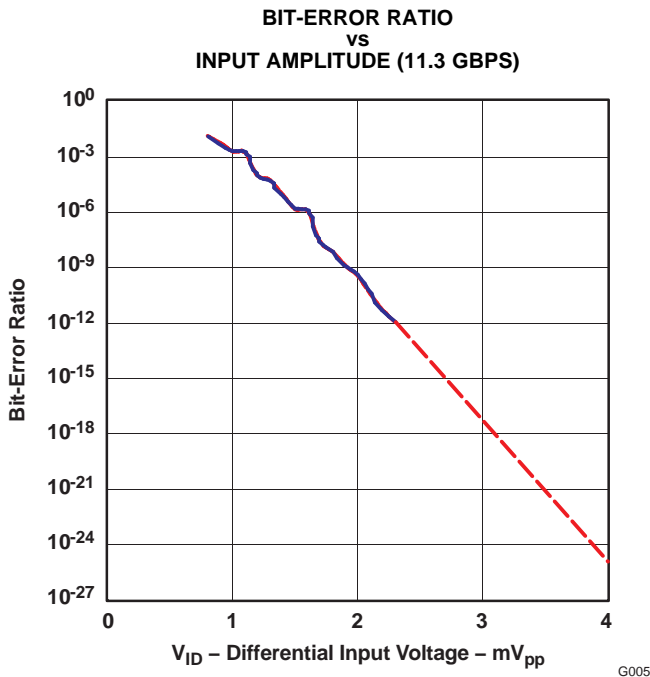

Figure 7.

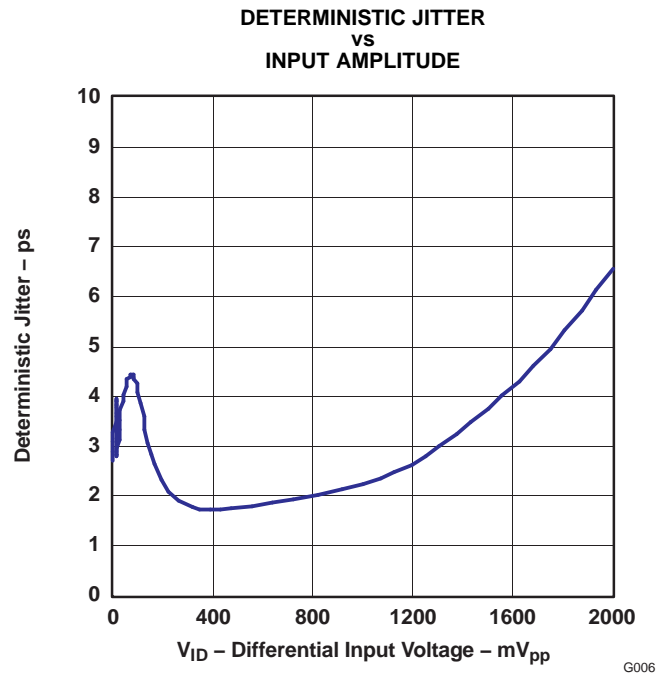

Figure 8.

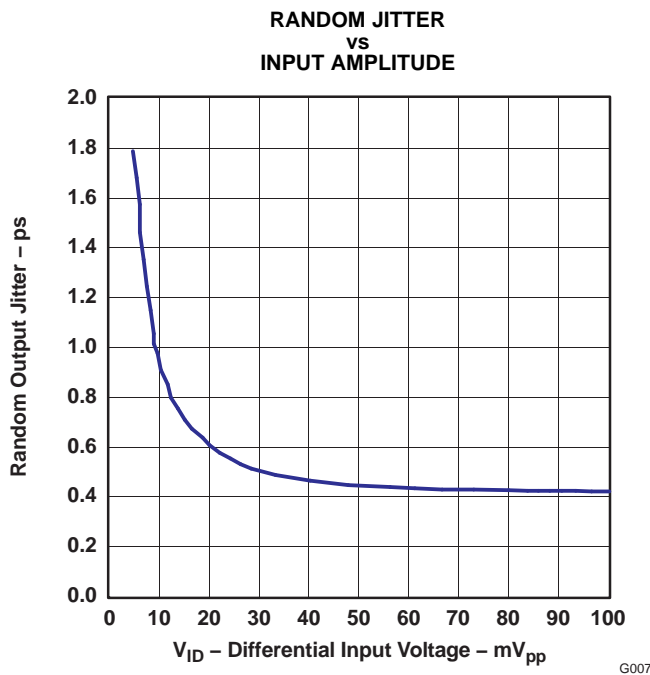

Figure 9.

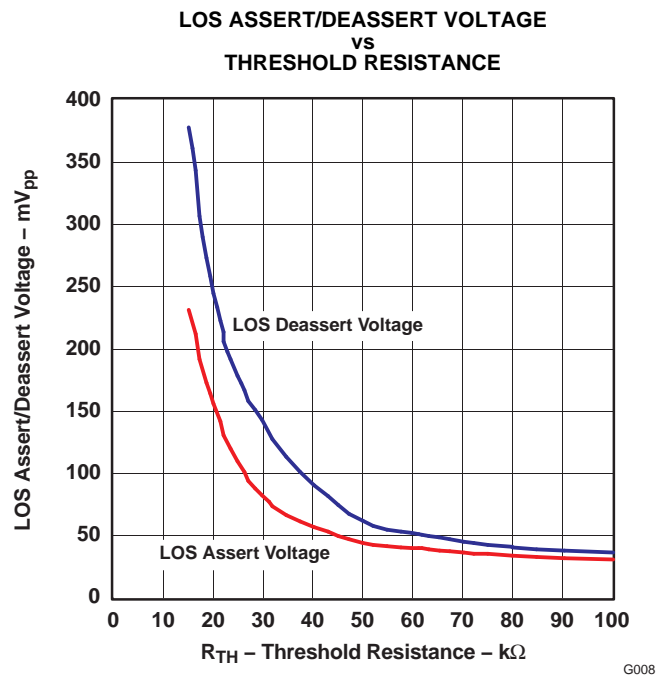

Figure 10.

TYPICAL OPERATION CHARACTERISTICS (continued)

Typical operating condition is at  $V_{CC} = 3.3\text{ V}$ ,  $T_A = 25^\circ\text{C}$ , and  $R_{VAR} = \text{open}$  (unless otherwise noted)

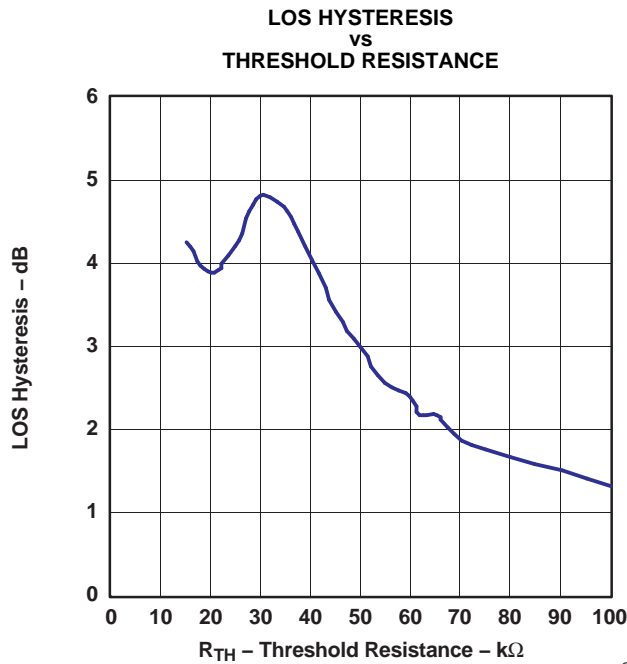

Figure 11.

G009

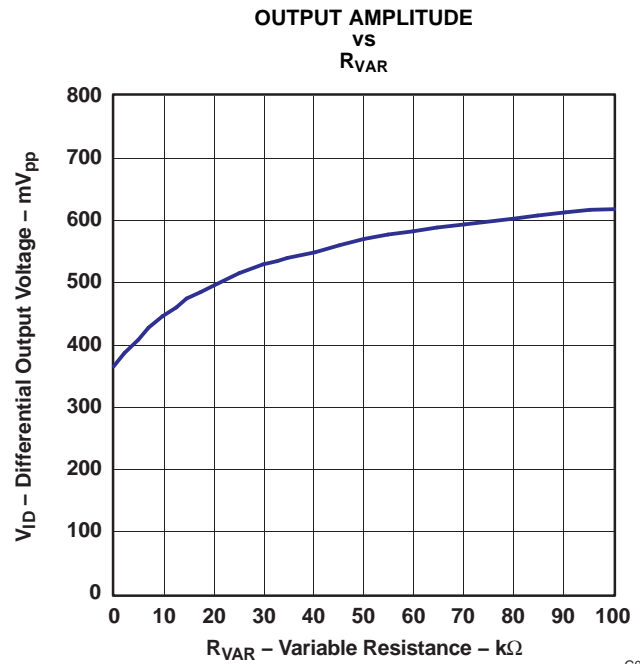

Figure 12.

G010

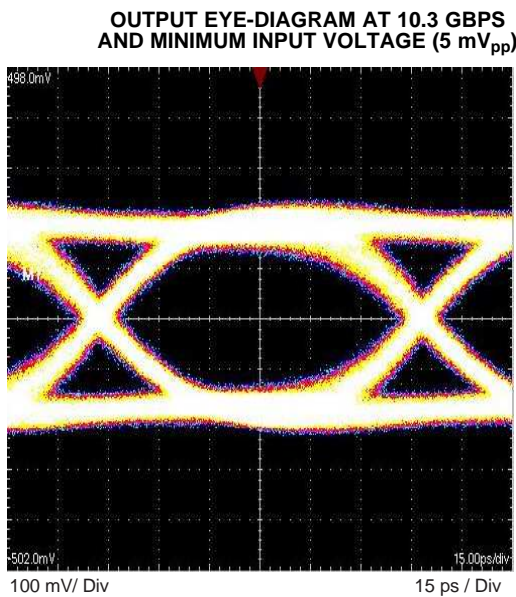

Figure 13.

G011

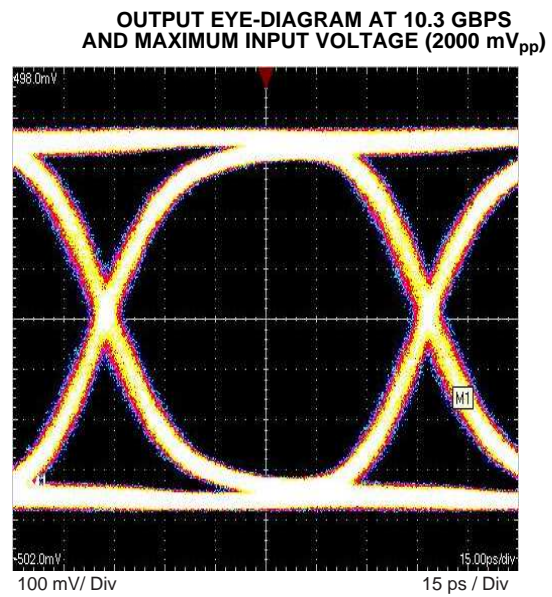

Figure 14.

G012

### TYPICAL OPERATION CHARACTERISTICS (continued)

Typical operating condition is at  $V_{CC} = 3.3\text{ V}$ ,  $T_A = 25^\circ\text{C}$ , and  $R_{VAR} = \text{open}$  (unless otherwise noted)

OUTPUT EYE-DIAGRAM AT 8.5 GBPS  
AND MINIMUM INPUT VOLTAGE (5 mV<sub>pp</sub>)

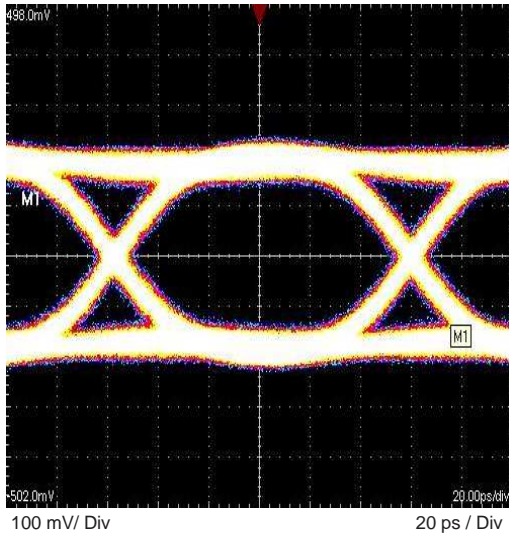

G013

Figure 15.

OUTPUT EYE-DIAGRAM AT 8.5 GBPS  
AND MAXIMUM INPUT VOLTAGE (2000 mV<sub>pp</sub>)

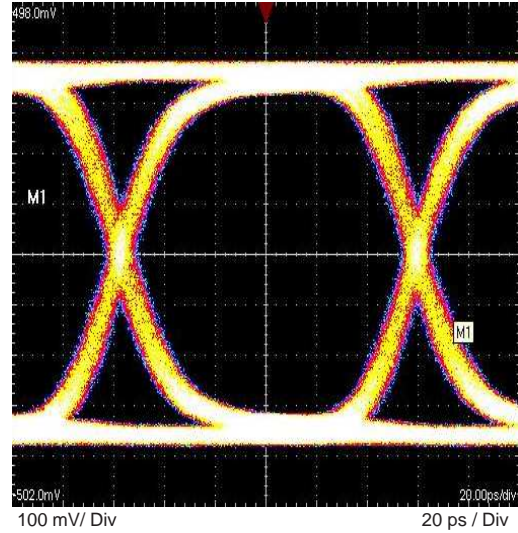

G014

Figure 16.

APPLICATION INFORMATION

Figure 17 shows a typical application circuit using the ONET1191P. The output amplitude can be adjusted with  $R_{VAR}$  and the LOS assert voltage is adjusted with  $R_{TH}$ .

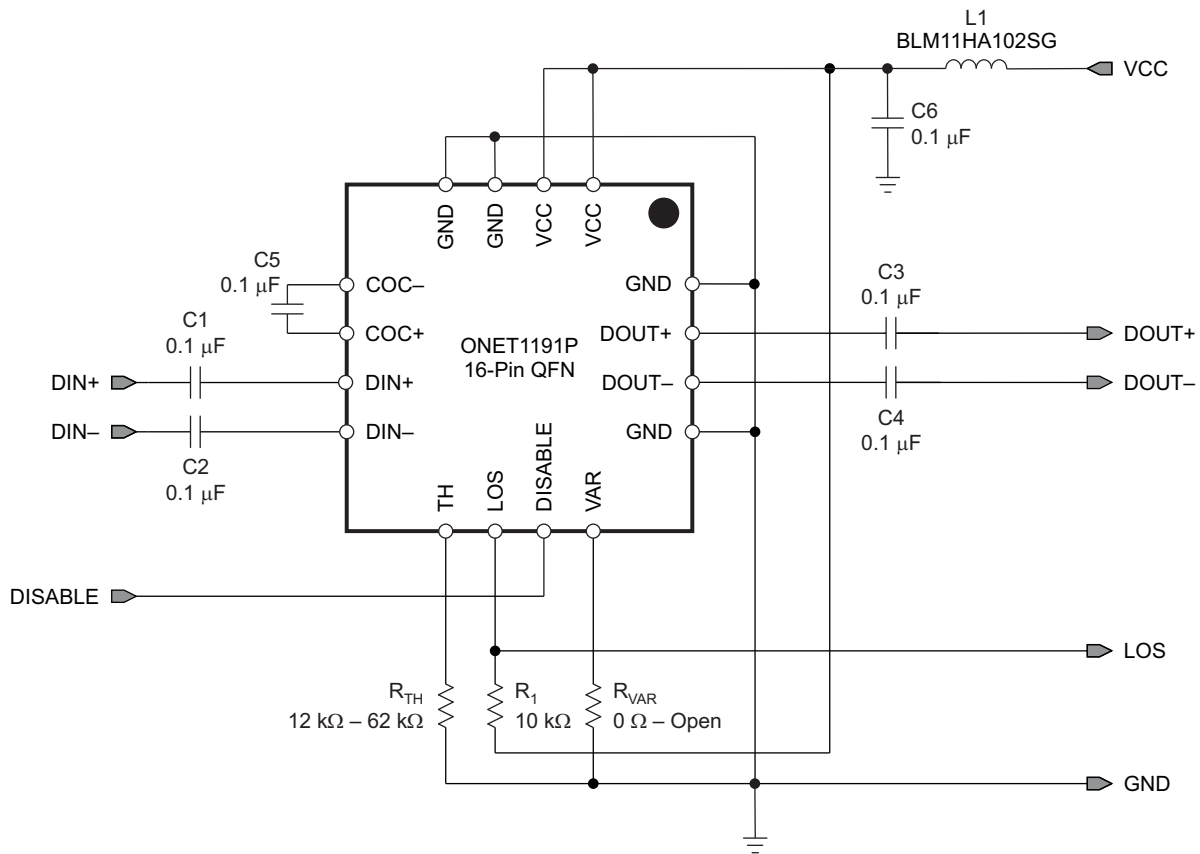

S0099-03

Figure 17. Basic Application Circuit

**PACKAGING INFORMATION**

Orderable Device	Status (1)	Package Type	Package Drawing	Pins	Package Qty	Eco Plan (2)	Lead/Ball Finish (6)	MSL Peak Temp (3)	Op Temp (°C)	Device Marking (4/5)	Samples
ONET1191PRGTR	ACTIVE	VQFN	RGT	16	3000	Green (RoHS & no Sb/Br)	CU NIPDAU	Level-2-260C-1 YEAR	-40 to 85	191P	<a href="#">Samples</a>
ONET1191PRGTRG4	ACTIVE	VQFN	RGT	16	3000	Green (RoHS & no Sb/Br)	CU NIPDAU	Level-2-260C-1 YEAR	-40 to 85	191P	<a href="#">Samples</a>
ONET1191PRGTT	ACTIVE	VQFN	RGT	16	250	Green (RoHS & no Sb/Br)	CU NIPDAU	Level-2-260C-1 YEAR	-40 to 85	191P	<a href="#">Samples</a>
ONET1191PRGTTG4	ACTIVE	VQFN	RGT	16	250	Green (RoHS & no Sb/Br)	CU NIPDAU	Level-2-260C-1 YEAR	-40 to 85	191P	<a href="#">Samples</a>

(1) The marketing status values are defined as follows:

**ACTIVE:** Product device recommended for new designs.

**LIFEBUY:** TI has announced that the device will be discontinued, and a lifetime-buy period is in effect.

**NRND:** Not recommended for new designs. Device is in production to support existing customers, but TI does not recommend using this part in a new design.

**PREVIEW:** Device has been announced but is not in production. Samples may or may not be available.

**OBSOLETE:** TI has discontinued the production of the device.

(2) **RoHS:** TI defines "RoHS" to mean semiconductor products that are compliant with the current EU RoHS requirements for all 10 RoHS substances, including the requirement that RoHS substance do not exceed 0.1% by weight in homogeneous materials. Where designed to be soldered at high temperatures, "RoHS" products are suitable for use in specified lead-free processes. TI may reference these types of products as "Pb-Free".

**RoHS Exempt:** TI defines "RoHS Exempt" to mean products that contain lead but are compliant with EU RoHS pursuant to a specific EU RoHS exemption.

**Green:** TI defines "Green" to mean the content of Chlorine (Cl) and Bromine (Br) based flame retardants meet JS709B low halogen requirements of <=1000ppm threshold. Antimony trioxide based flame retardants must also meet the <=1000ppm threshold requirement.

(3) MSL, Peak Temp. - The Moisture Sensitivity Level rating according to the JEDEC industry standard classifications, and peak solder temperature.

(4) There may be additional marking, which relates to the logo, the lot trace code information, or the environmental category on the device.

(5) Multiple Device Markings will be inside parentheses. Only one Device Marking contained in parentheses and separated by a "-" will appear on a device. If a line is indented then it is a continuation of the previous line and the two combined represent the entire Device Marking for that device.

(6) Lead/Ball Finish - Orderable Devices may have multiple material finish options. Finish options are separated by a vertical ruled line. Lead/Ball Finish values may wrap to two lines if the finish value exceeds the maximum column width.

**Important Information and Disclaimer:** The information provided on this page represents TI's knowledge and belief as of the date that it is provided. TI bases its knowledge and belief on information provided by third parties, and makes no representation or warranty as to the accuracy of such information. Efforts are underway to better integrate information from third parties. TI has taken and

continues to take reasonable steps to provide representative and accurate information but may not have conducted destructive testing or chemical analysis on incoming materials and chemicals. TI and TI suppliers consider certain information to be proprietary, and thus CAS numbers and other limited information may not be available for release.

In no event shall TI's liability arising out of such information exceed the total purchase price of the TI part(s) at issue in this document sold by TI to Customer on an annual basis.

**TAPE AND REEL INFORMATION**

**QUADRANT ASSIGNMENTS FOR PIN 1 ORIENTATION IN TAPE**

\*All dimensions are nominal

Device	Package Type	Package Drawing	Pins	SPQ	Reel Diameter (mm)	Reel Width W1 (mm)	A0 (mm)	B0 (mm)	K0 (mm)	P1 (mm)	W (mm)	Pin1 Quadrant
ONET1191PRGTR	VQFN	RGT	16	3000	330.0	12.4	3.3	3.3	1.1	8.0	12.0	Q2
ONET1191PRGTT	VQFN	RGT	16	250	180.0	12.4	3.3	3.3	1.1	8.0	12.0	Q2

**TAPE AND REEL BOX DIMENSIONS**

\*All dimensions are nominal

Device	Package Type	Package Drawing	Pins	SPQ	Length (mm)	Width (mm)	Height (mm)
ONET1191PRGTR	VQFN	RGT	16	3000	350.0	350.0	43.0
ONET1191PRGTT	VQFN	RGT	16	250	210.0	185.0	35.0

**RGT 16**

**GENERIC PACKAGE VIEW**

**VQFN - 1 mm max height**

PLASTIC QUAD FLATPACK - NO LEAD

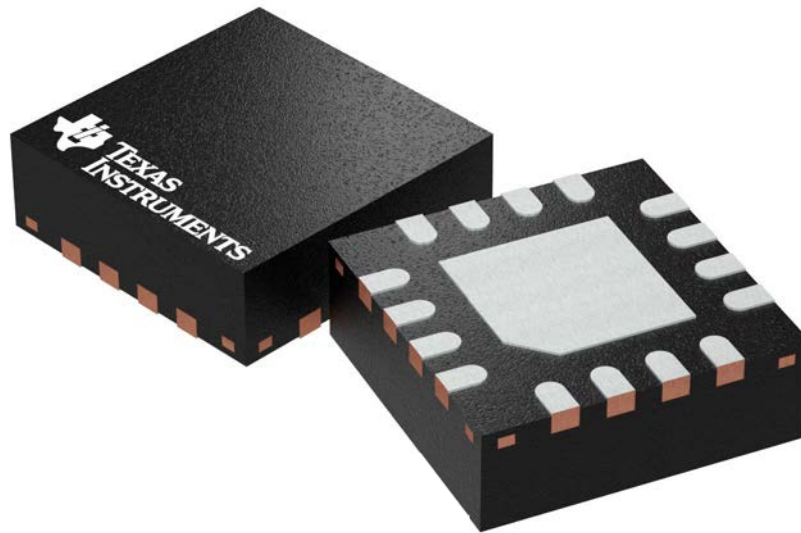

Images above are just a representation of the package family, actual package may vary.  
Refer to the product data sheet for package details.

4203495/1

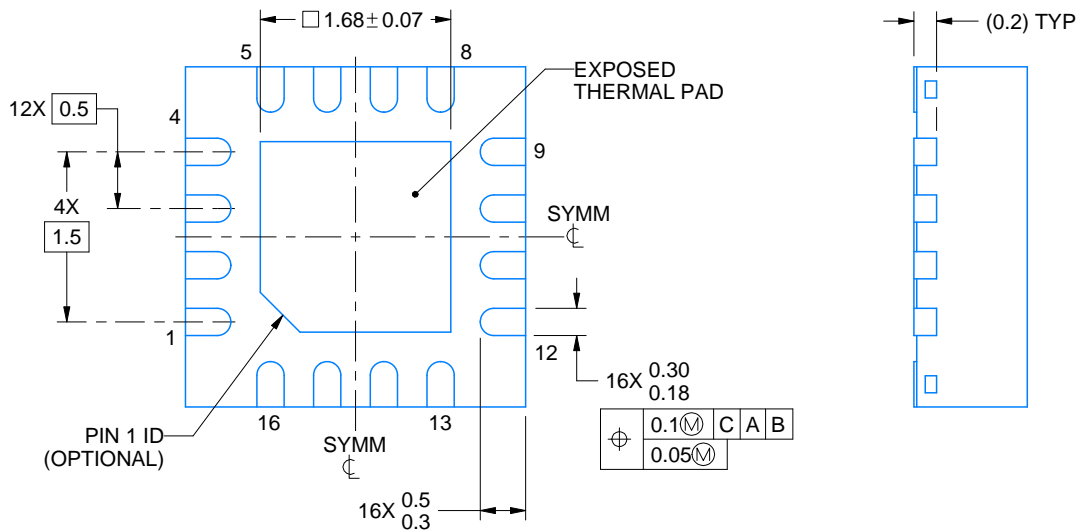
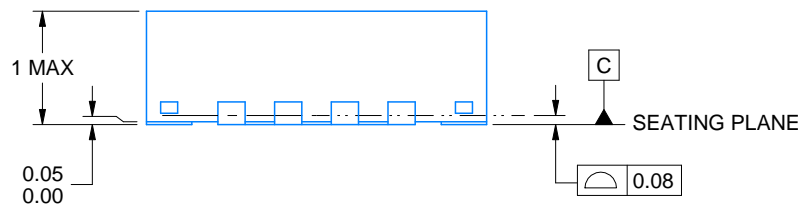
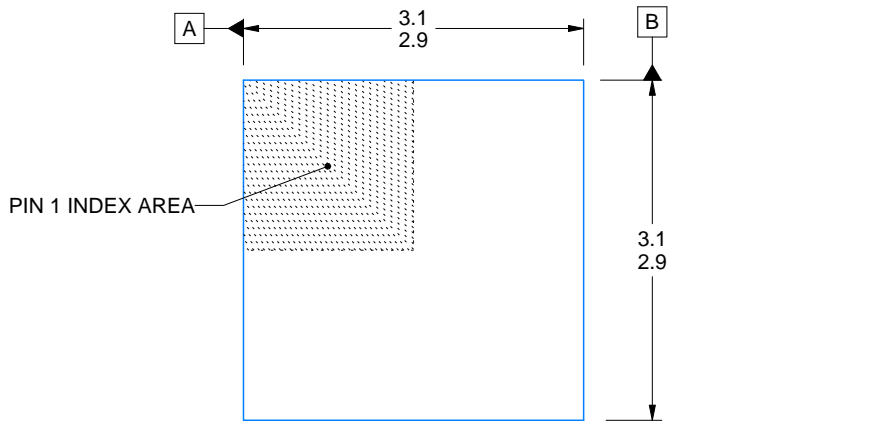
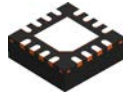

4222419/B 11/2016

NOTES:

1. All linear dimensions are in millimeters. Any dimensions in parenthesis are for reference only. Dimensioning and tolerancing per ASME Y14.5M.
2. This drawing is subject to change without notice.
3. The package thermal pad must be soldered to the printed circuit board for thermal and mechanical performance.



# EXAMPLE STENCIL DESIGN

RGT0016C

VQFN - 1 mm max height

PLASTIC QUAD FLATPACK - NO LEAD

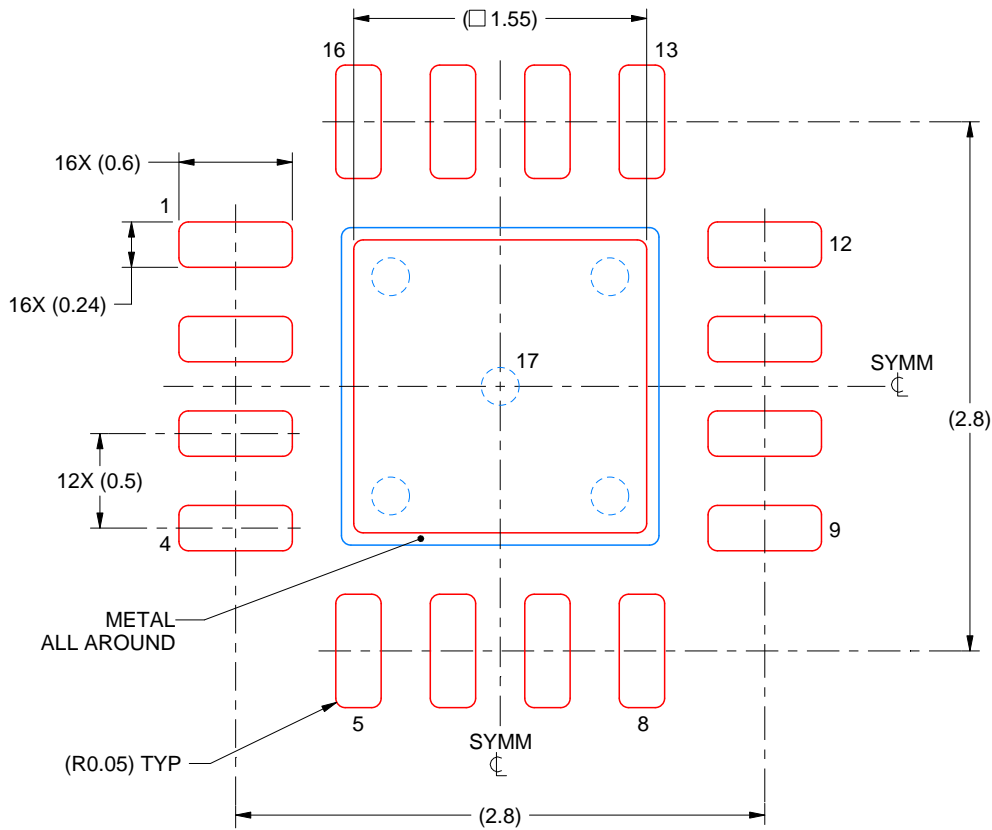

**SOLDER PASTE EXAMPLE**  
BASED ON 0.125 mm THICK STENCIL

EXPOSED PAD 17:  
85% PRINTED SOLDER COVERAGE BY AREA UNDER PACKAGE  
SCALE:25X

4222419/B 11/2016

NOTES: (continued)

6. Laser cutting apertures with trapezoidal walls and rounded corners may offer better paste release. IPC-7525 may have alternate design recommendations.

## IMPORTANT NOTICE AND DISCLAIMER

TI PROVIDES TECHNICAL AND RELIABILITY DATA (INCLUDING DATASHEETS), DESIGN RESOURCES (INCLUDING REFERENCE DESIGNS), APPLICATION OR OTHER DESIGN ADVICE, WEB TOOLS, SAFETY INFORMATION, AND OTHER RESOURCES "AS IS" AND WITH ALL FAULTS, AND DISCLAIMS ALL WARRANTIES, EXPRESS AND IMPLIED, INCLUDING WITHOUT LIMITATION ANY IMPLIED WARRANTIES OF MERCHANTABILITY, FITNESS FOR A PARTICULAR PURPOSE OR NON-INFRINGEMENT OF THIRD PARTY INTELLECTUAL PROPERTY RIGHTS.

These resources are intended for skilled developers designing with TI products. You are solely responsible for (1) selecting the appropriate TI products for your application, (2) designing, validating and testing your application, and (3) ensuring your application meets applicable standards, and any other safety, security, or other requirements. These resources are subject to change without notice. TI grants you permission to use these resources only for development of an application that uses the TI products described in the resource. Other reproduction and display of these resources is prohibited. No license is granted to any other TI intellectual property right or to any third party intellectual property right. TI disclaims responsibility for, and you will fully indemnify TI and its representatives against, any claims, damages, costs, losses, and liabilities arising out of your use of these resources.

TI's products are provided subject to TI's Terms of Sale ([www.ti.com/legal/termsofsale.html](http://www.ti.com/legal/termsofsale.html)) or other applicable terms available either on [ti.com](http://ti.com) or provided in conjunction with such TI products. TI's provision of these resources does not expand or otherwise alter TI's applicable warranties or warranty disclaimers for TI products.

Mailing Address: Texas Instruments, Post Office Box 655303, Dallas, Texas 75265  
Copyright © 2019, Texas Instruments Incorporated

## Looking for pricing, stock, or lifecycle information?

Click below to explore more details on WIN SOURCE:

 [View ONET1191PRGTR on WIN SOURCE](#)

 [Texas Instruments](#) Information

## Optimize Your Supply Chain with WIN SOURCE Solutions

-  Global Sourcing Solution
-  Obsolete Management
-  Cost Control Management
-  Shortage Management
-  Alternative Solution
-  Excess Inventory Management