

# CNC1S171 (ON3171)

## Optoisolator

For isolated signal transmission

### ■ Features

- High current transfer ratio: CTR > 50%
- High I/O isolation voltage:  $V_{ISO} = 5\,000\text{ V[rms]}$  (min.)
- Fast response:  $t_r = 2\ \mu\text{s}$ ,  $t_f = 3\ \mu\text{s}$  (typ.)
- Low collector-emitter cutoff current (base open):  $I_{CEO} < 100\ \text{nA}$
- UL listed (UL File No. E79920)

### ■ Absolute Maximum Ratings $T_a = 25^\circ\text{C}$

Parameter		Symbol	Rating	Unit
Input (Light emitting diode)	Power dissipation *1	$P_D$	75	mW
	Forward current	$I_F$	50	mA
	Pulse forward current *2	$I_{FP}$	1	A
	Reverse voltage	$V_R$	6	V
Output (Photo transistor)	Collector-emitter voltage (Base open)	$V_{CEO}$	80	V
	Emitter-collector voltage (Base open)	$V_{ECO}$	7	V
	Collector current	$I_C$	50	mA
	Collector power dissipation *3	$P_C$	150	mW
Isolation voltage, input to output *4		$V_{ISO}$	5000	V[rms]
Total power dissipation		$P_T$	200	mW
Operating ambient temperature		$T_{opr}$	-30 to +100	°C
Storage temperature		$T_{stg}$	-55 to +125	°C

Note) \*1: Input power derating ratio is 0.75 mW/°C at  $T_a \geq 25^\circ\text{C}$ .

\*2: Pulse width  $\leq 100\ \mu\text{s}$ , repeat 100 pps

\*3: Output power derating ratio is 1.5 mW/°C at  $T_a \geq 25^\circ\text{C}$ .

\*4: AC 1 min. RH < 60%

Note) The part number in the parenthesis shows conventional part number.

■ Electrical-Optical Characteristics  $T_a = 25^\circ\text{C} \pm 3^\circ\text{C}$

Parameter		Symbol	Conditions	Min	Typ	Max	Unit
Input characteristics	Reverse current	$I_R$	$V_R = 3\text{ V}$			10	$\mu\text{A}$
	Forward voltage	$V_F$	$I_F = 50\text{ mA}$		1.35	1.5	V
	Terminal capacitance	$C_t$	$V_R = 0\text{ V}, f = 1\text{ MHz}$		15		pF
Output characteristics	Collector-emitter voltage (Base open)	$V_{\text{CEO}}$	$I_C = 100\ \mu\text{A}$	80			V
	Emitter-collector voltage (Base open)	$V_{\text{ECO}}$	$I_E = 10\ \mu\text{A}$	7			V
	Collector-emitter cutoff current (Base open)	$I_{\text{CEO}}$	$V_{\text{CE}} = 20\text{ V}$		5	100	nA
	Collector-emitter capacitance	$C_C$	$V_{\text{CE}} = 10\text{ V}, f = 1\text{ MHz}$		10		pF
Transfer characteristics	DC current transfer ratio *1	CTR	$V_{\text{CE}} = 10\text{ V}, I_F = 5\text{ mA}$	50		600	%
	Isolation capacitance, input to output	$C_{\text{ISO}}$	$f = 1\text{ MHz}$		0.7		pF
	Isolation resistance, input to output	$R_{\text{ISO}}$	$V_{\text{ISO}} = 500\text{ V}$	$10^{11}$			$\Omega$
	Rise time *2	$t_r$	$V_{\text{CC}} = 10\text{ V}, I_C = 2\text{ mA}, R_L = 100\ \Omega$		2		$\mu\text{s}$
	Fall time *3	$t_f$	$\Omega$		3		$\mu\text{s}$
	Collector-emitter saturation voltage	$V_{\text{CE(sat)}}$	$I_F = 20\text{ mA}, I_C = 1\text{ mA}$		0.1	0.2	V

Note) 1. Input and output are practiced by electricity.

2. This device is designed by disregarding radiation.

3. \*1:

$$\text{CTR} = \frac{I_C}{I_F} \times 100\%$$

\*2:  $t_r$ : Time required for the collector current to increase from 10% to 90% of its final value

\*3:  $t_f$ : Time required for the collector current to decrease from 90% to 10% of its initial value

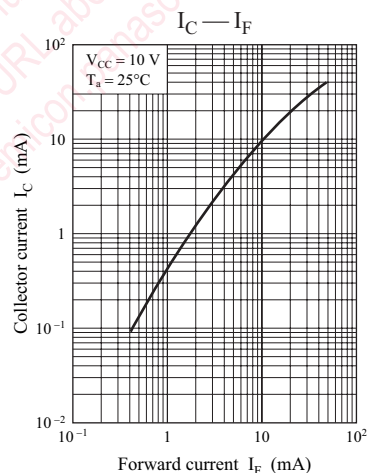
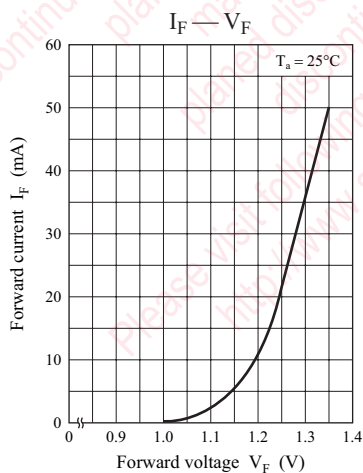
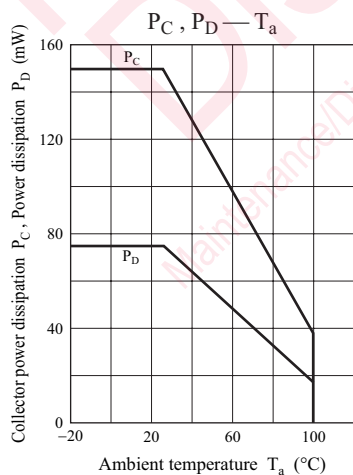

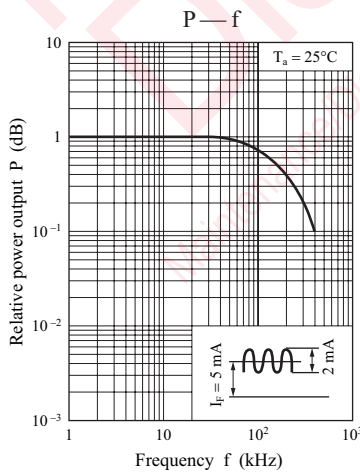
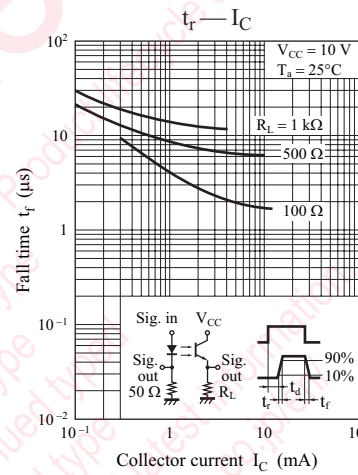
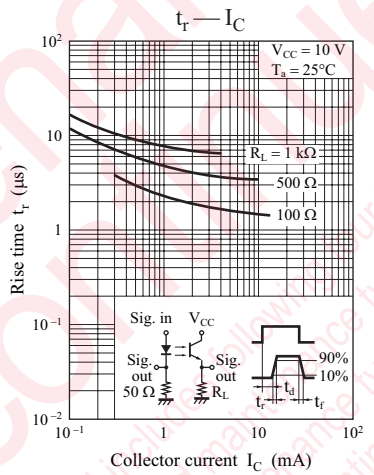
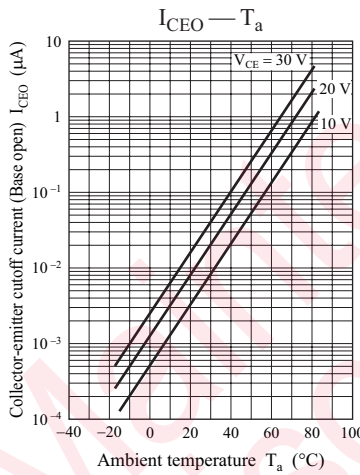
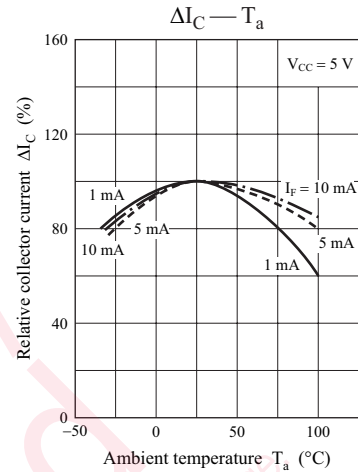
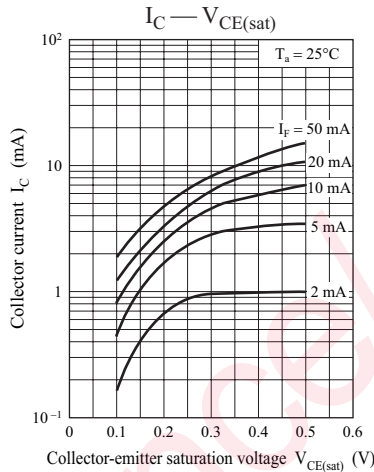
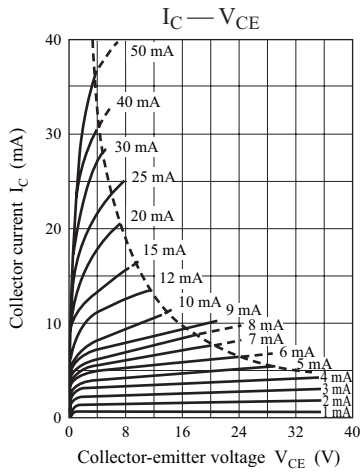

Measurement circuit of frequency characteristics

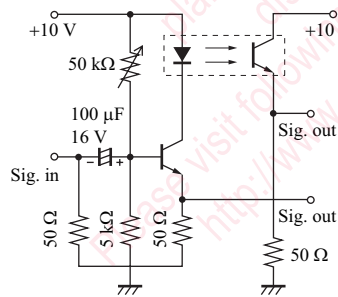

■ Package (Unit: mm)

LCTXXN4Z0002

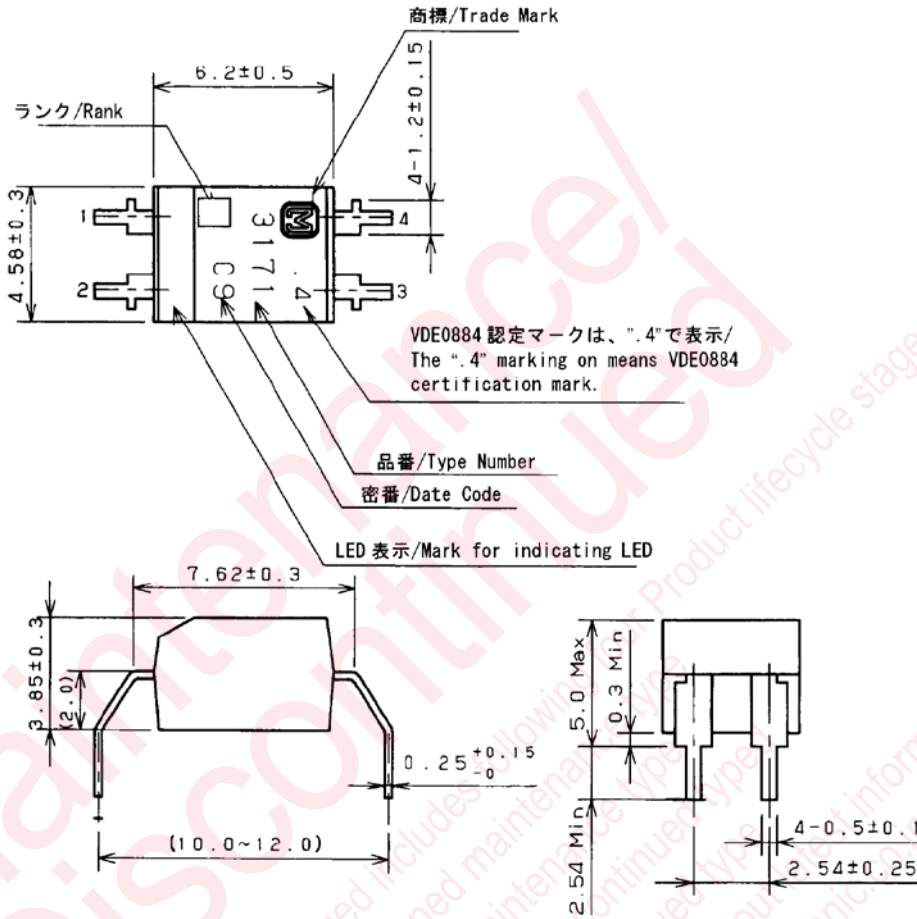

(注1) マークは、目視又は顕微鏡に於いて解読できる事。  
(Note1) What a mark sees an attention and can decode in a microscope.

- Pin name
  - 1: Anode
  - 2: Cathode
  - 3: Emitter
  - 4: Collector

## utions in using the technical information and scribed in this book

book is to be exported or provided to non-residents, the laws and  
d to security export control, must be observed.

y to show the main characteristics and application circuit examples  
property right or other right owned by Panasonic Corporation or any  
company as to the infringement upon any such right owned by any  
information described in this book.

standard applications or general electronic equipment (such as office  
and household appliances).

g applications:

obiles, traffic control equipment, combustion equipment, life support  
reliability are required, or if the failure or malfunction of the prod-

are subject to change without notice for modification and/or im-  
se of the products, therefore, ask for the most up-to-date Product  
atisfy your requirements.

bsolute maximum rating and the guaranteed operating conditions  
) . Especially, please be careful not to exceed the range of absolute  
r-off and mode-switching. Otherwise, we will not be liable for any



take into the consideration of incidence of break down and failure  
n the systems such as redundant design, arresting the spread of fire  
al injury, fire, social damages, for example, by using the products.

own and characteristics change due to external factors (ESD, EOS,  
mounting or at customer's process. When using products for which  
elf life and the elapsed time since first opening the packages.

partially, without the prior written permission of our company.

## Looking for pricing, stock, or lifecycle information?

Click below to explore more details on WIN SOURCE:

-  [View ON3171 on WIN SOURCE](#)
-  [Panasonic Information](#)

## Optimize Your Supply Chain with WIN SOURCE Solutions

-  Global Sourcing Solution
-  Obsolete Management
-  Cost Control Management
-  Shortage Management
-  Alternative Solution
-  Excess Inventory Management