



**THE DATASHEET OF  
OJE-SH-112LMH,000**



4

3

2

1

THIS DRAWING IS UNPUBLISHED.

RELEASED FOR PUBLICATION

© COPYRIGHT - By - TE CONNECTIVITY

ALL RIGHTS RESERVED.

LOC  
HB

DIST  
-

REVISIONS

P	LTR	DESCRIPTION	DATE	DWN	APVD
	E	REMOVED THE RIB ON THE BASE TO CASE ECO-15-011310	03-Dec-15	YS.H	HLC
	E1	ADD NEW PN ECO-18-008228	25-May-18	WQ.Y	K.T

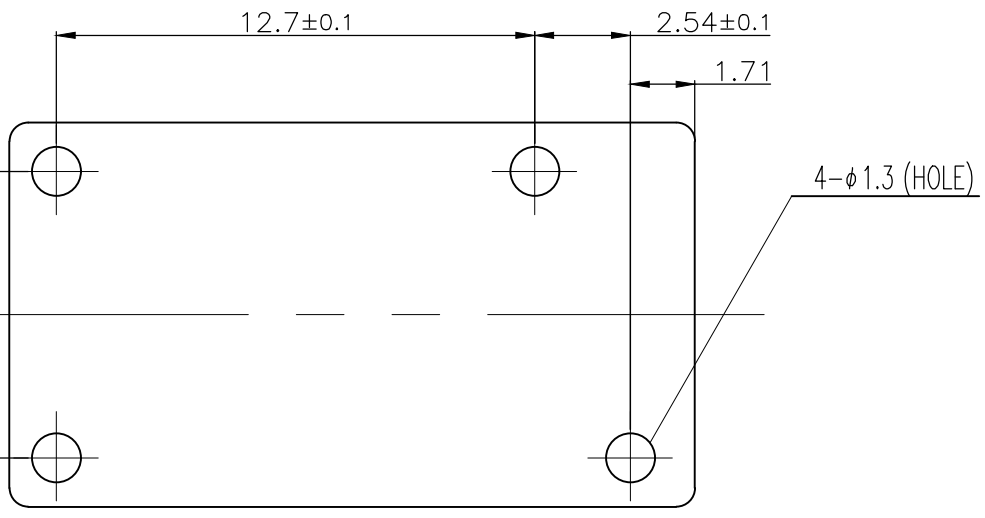
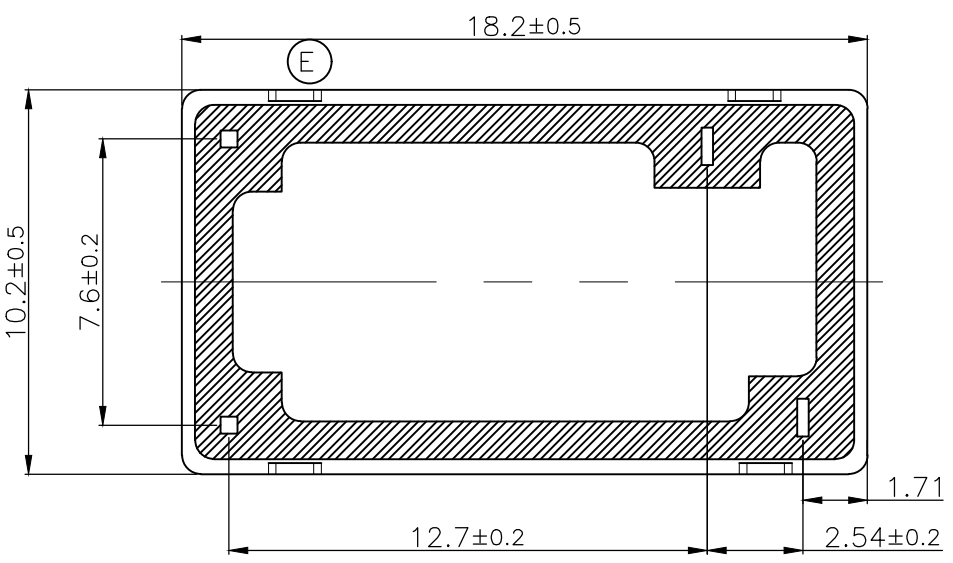
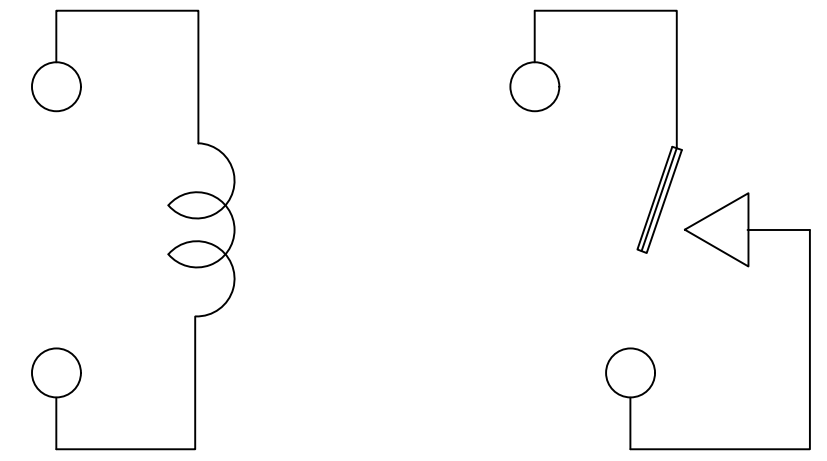
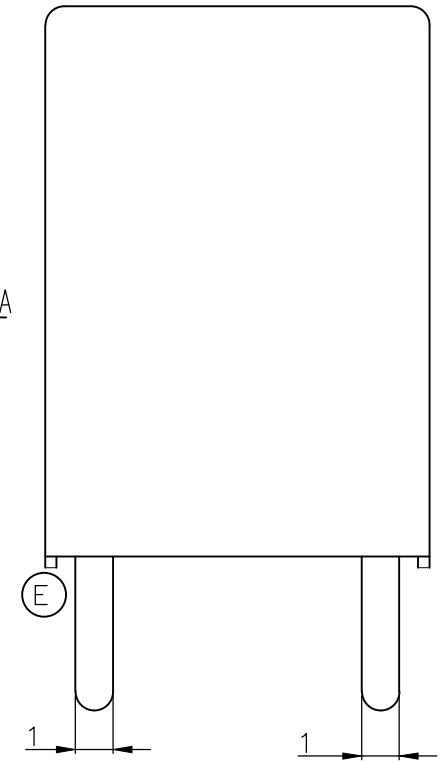
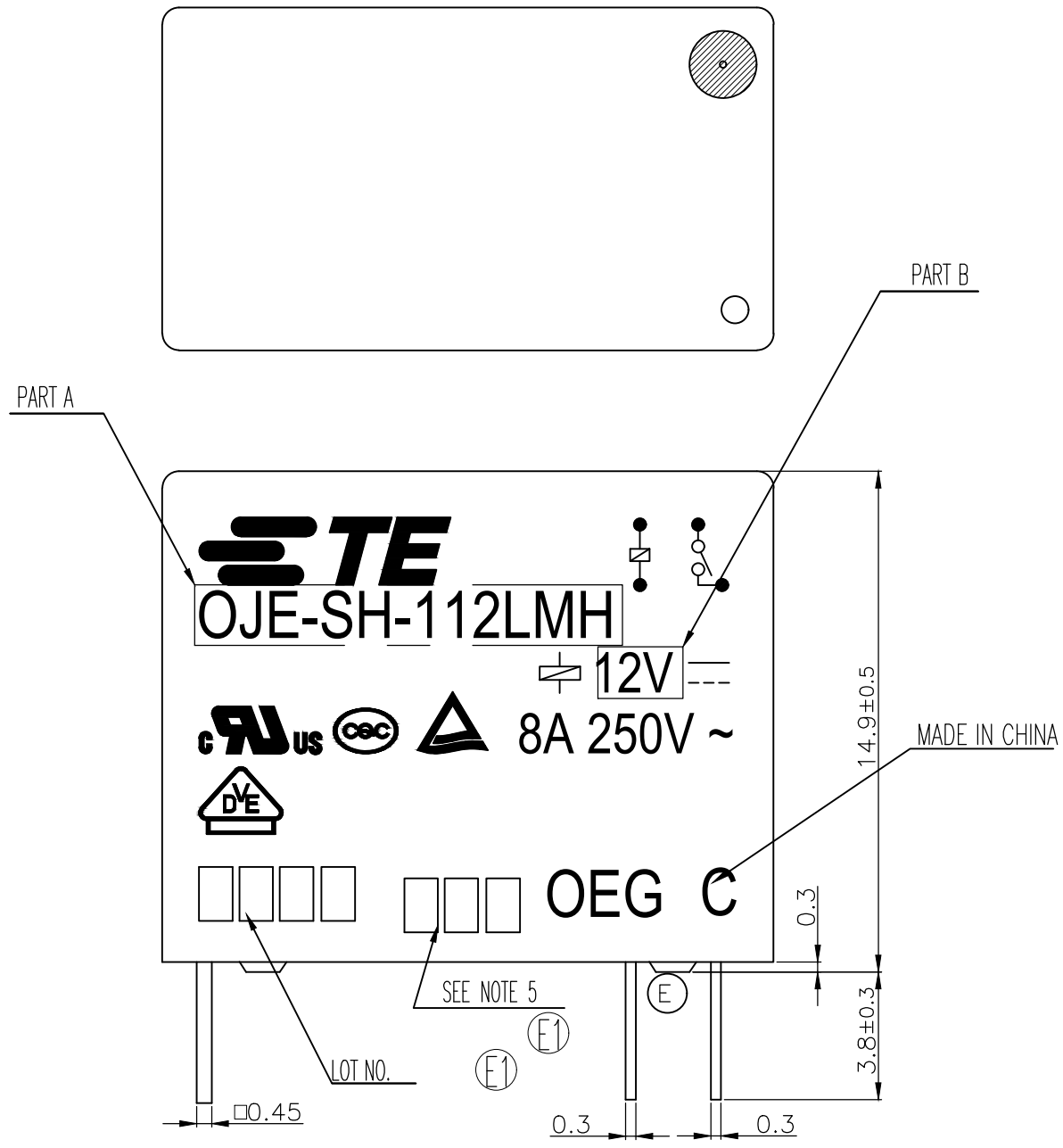

THIS DRAWING IS A CONTROLLED DOCUMENT.		DWN	H.SASAKI					
DIMENSIONS: mm		CHK	Y.OIKAWA					
TOLERANCES UNLESS OTHERWISE SPECIFIED:		APVD	S.NAGAI		NAME			
0 PLC ± -		PRODUCT SPEC	SEE PRODUCT SPEC		OJE-SH-LMH CUSTOMER DRAWING			
1 PLC ± -		APPLICATION SPEC	-		SIZE	CAGE CODE	DRAWING NO	RESTRICTED TO
2 PLC ± -					A3	00779	1461403	-
3 PLC ± -					SCALE			SHEET
4 PLC ± -					5:1			1 of 2
ANGLES ± -					REV			E1
MATERIAL		FINISH			CUSTOMER DRAWING			

THIS DRAWING IS UNPUBLISHED. RELEASED FOR PUBLICATION  
 © COPYRIGHT - By - TE CONNECTIVITY ALL RIGHTS RESERVED.

LOC	DIST	REVISIONS					
		P	LTR	DESCRIPTION	DATE	DWN	APVD
HB	-	-	-	SEE SHEET 1	-	-	-

FIG	TE PART NO	TE TYPE NAME	PACKAGE SPEC	PART B	PART A	TYPE		
D	C	B	1461403-7	OJE-SH-124LMH	107-84031	24V	OJE-SH-124LMH	g
			1461403-5	OJE-SH-124LMH	107-79010	24V	OJE-SH-124LMH	f
			1461403-4	OJE-SH-112LMH	107-79010	12V	OJE-SH-112LMH	e
			1461403-2	OJE-SH-109LMH	107-79010	9V	OJE-SH-109LMH	d
			1461403-1	OJE-SH-106LMH	107-79010	6V	OJE-SH-106LMH	c
			1461403-3	OJE-SH-105LMH	107-79010	5V	OJE-SH-105LMH	b
			1461403-6	OJE-SH-103LMH	107-79010	3V	OJE-SH-103LMH	a

RELAY TYPE

- NOTES:**  
 1.ALL LOGO TO BE SCALE DOWNED  
 2.FONT IS AIARL NARROW.  
 3.PRODUCT SPECIFICATION AS SHOWN AT TABLE  
 4.USE LASER MACHINE TO PRINT.

**FIG A** 5.LOT NO. SYSTEM AS FOLLOWING:

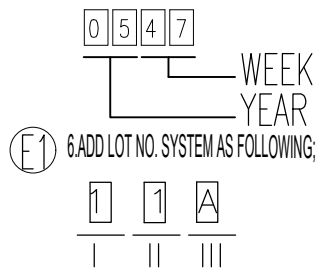

- 6.ADD LOT NO. SYSTEM AS FOLLOWING;
- I, DIGITS FOR DAY OF THE WEEK  
 1...MONDAY IN THIS WEEK;  
 2...TUESDAY IN THIS WEEK;  
 .....  
 7...SUNDAY IN THIS WEEK
- II, DIGITS FOR SHIFT OF THE DAY  
 1...DAY SHIFT IN THIS DAY;  
 2...NIGHT SHIFT IN THIS DAY;
- III, ONE CHARACTER DISTINGUISH THE LINE IDENTITY, SUCH AS: A,B.....Z

**FIG B** 5.LOT NO.SYSTEM AS FOLLOWING:

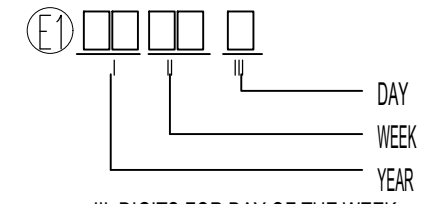

- III, DIGITS FOR DAY OF THE WEEK  
 1...MONDAY IN THIS WEEK;  
 2...TUESDAY IN THIS WEEK;  
 .....  
 7...SUNDAY IN THIS WEEK
- 6.ADD LOT NO. SYSTEM AS FOLLOWING;
- I, DIGITS FOR SHIFT OF THE DAY  
 1...DAY SHIFT IN THIS DAY;  
 2...NIGHT SHIFT IN THIS DAY;
- II, ONE CHARACTER DISTINGUISH THE LINE IDENTITY, SUCH AS: A,B.....Z
7. ANTI-EXPLOSIVE CERTIFICATION NUMBER,

INCOMBUSTIBILITY	TREATMENT	MATERIAL	DESCRIPTION	ITEM
		UV RESIN	SEEL (VENT HOLE)	16
		EPOXY RESIN	SEEL (BASE & BOBBIN)	15
		3UEW	MAGNETIC WIRE	14
94V-0		P.B.T	CASE	13
94V-0		P.B.T	BASE	12
94V-0		P.B.T	BOBBIN	11
	SOLDER DIP	C.P WIRE	COIL TERMINAL	10
FIG C	94V-0	LCP	CARD	9
FIG D	94V-0	P.P.S	CARD	
		Ag ALLOY	MOVABLE CONTACT	8
		Ag ALLOY	NO.CONTACT	7
		STEEL	HINGE SPRING	6
	SOLDER DIP	Cu ALLOY	NO.TERMINAL	5
	SOLDER DIP	Cu ALLOY	MOVABLE SPRING	4
	NIP	STEEL	CORE	3
	NIP	STEEL	ARMATURE	2
	NIP	STEEL	YOKE	1

THIS DRAWING IS A CONTROLLED DOCUMENT.		DWN	H.SASAKI	TE Connectivity OJE-SH-LMH CUSTOMER DRAWING								
DIMENSIONS: mm		CHK	Y.OIKAWA									
TOLERANCES UNLESS OTHERWISE SPECIFIED:		APVD	S.NAGAI									
0 PLC ± - 1 PLC ± - 2 PLC ± - 3 PLC ± - 4 PLC ± - ANGLES ± -		PRODUCT SPEC	SEE PRODUCT SPEC									
MATERIAL		APPLICATION SPEC	-	SIZE	A3	CAGE CODE	00779	DRAWING NO	1461403	RESTRICTED TO	-	
FINISH		WEIGHT	-	CUSTOMER DRAWING			SCALE	5:1	SHEET	2 of 2	REV	E1

## Looking for pricing, stock, or lifecycle information?

Click below to explore more details on WIN SOURCE:

 [View OJE-SH-112LMH,000 on WIN SOURCE](#)

 [TE Connectivity](#) Information

## Optimize Your Supply Chain with WIN SOURCE Solutions

-  Global Sourcing Solution
-  Obsolete Management
-  Cost Control Management
-  Shortage Management
-  Alternative Solution
-  Excess Inventory Management