



**THE DATASHEET OF
NTE864**





ELECTRONICS, INC.
 44 FARRAND STREET
 BLOOMFIELD, NJ 07003
 (973) 748-5089
<http://www.nteinc.com>

NTE864 Integrated Circuit Precision Waveform Generator

Description:

The NTE864 is a precision waveform generator in a 14-Lead DIP type package capable of producing high accuracy sine, square, triangular, sawtooth and pulse waveforms. The frequency (or repetition rate) can be selected externally from 0.001Hz to 300kHz. The frequency of oscillation is highly stable over a wide range of temperature and supply voltage changes. Both full frequency sweeping as well as smaller frequency variations (FM) can be accomplished with an external control voltage. Each of the three basic waveforms, i.e., sinewave, triangle and square wave outputs are available simultaneously.

Applications:

- Low Frequency Drift with Temperature: 250ppm/°C
- Low Distortion: 1% (Sinewave Output)
- High Linearity: 0.1% (Triangle Wave Output)
- Wide Frequency Range: 0.001Hz to 300kHz
- variable Duty Cycle: 2% to 98%
- High Level Outputs: TTL to 28V
- Simultaneous Sine, Square, and Triangle Wave Outputs

Absolute Maximum Ratings: (Note 1)

Power Supply Voltage (V- to V+)	36V
Input Voltage (Any Pin)	V- to V+
Input Current (Pin4 and Pin5)	25mA
Output Sink Current (Pin3 and Pin9)	25mA
Maximum Junction Temperature, T _J	+150°C
Maximum Storage Temperature Range, T _{stg}	-65° to +150°C
Maximum Lead Temperature (Soldering, 10s), T _L	+300°C
Thermal Resistance, Junction-to-Ambient (Typical, Note 2), R _{thJA}	115°C/W

Recommended Operating Conditions:

Operating Temperature Range 0° to +70°C

Note 1. Stresses above those listed in “Absolute Maximum Ratings” may cause permanent damage to the device. This is a stress only rating and operation of the device at any of these of any other conditions above those indicated in the operational sections of this specification is not implied.

Note 2. R_{thJA} is measured with the component mounted on an elevation PC board in free air.

Electrical Characteristics: (V_{SUPPLY} = ±10V to ±20V, T_A = +25°C, R_L = 10kΩ unless otherwise specified)

Parameter	Symbol	Test Conditions	Min	Typ	Max	Unit
General Characteristics						
Supply Voltage Single Supply	V _{SUPPLY} V+		+10	-	+30	V
Dual Supplies			±5	-	±15	V
Supply Current	I _{SUPPLY}	V _{SUPPLY} = ±10V, Note 3	-	12	15	mA

Note 3. R_A and R_B currents not included.

Electrical Characteristics: ($V_{\text{SUPPLY}} = \pm 10\text{V}$ to $\pm 20\text{V}$, $T_A = +25^\circ\text{C}$, $R_L = 10\text{k}\Omega$ unless otherwise specified)

Parameter	Symbol	Test Conditions	Min	Typ	Max	Unit
Frequency Characteristics (All Waveforms)						
Max. Frequency of Oscillation	f_{MAX}		100	-	-	kHz
Sweep Frequency of FM Input	f_{SWEEP}		-	10	-	kHz
FM Sweep Range		Note 4	-	35:1	-	-
FM Linearity		10:1 Ratio	-	0.5	-	%
Frequency Drift with Temperature	$\Delta f/\Delta T$	0° to $+70^\circ\text{C}$, Note 5	-	250	-	ppm/ $^\circ\text{C}$
Frequency Drift with Supply Voltage	$\Delta f/\Delta V$	Over Supply Voltage Range	-	0.05	-	%/V
Output Characteristics						
Square Wave						
Leakage Current	I_{OLK}	$V_9 = 30\text{V}$	-	-	1	μA
Saturation Voltage	V_{SAT}	$I_{\text{SINK}} = 2\text{mA}$	-	0.2	0.5	V
Rise Time	t_{R}	$R_L = 4.7\text{k}\Omega$	-	180	-	ns
Fall Time	t_{F}	$R_L = 4.7\text{k}\Omega$	-	40	-	ns
Duty Cycle Adjust	ΔD	Note 6	2	-	98	%
Triangle/Sawtooth/Ramp						
Amplitude	V_{TRIANGLE}	$R_{\text{TRI}} = 100\text{k}\Omega$	0.3	0.33	-	$\times V_{\text{SUPPLY}}$
Linearity			-	0.1	-	%
Output Impedance	Z_{OUT}	$I_{\text{OUT}} = 5\text{mA}$	-	200	-	Ω
Sine-Wave						
Amplitude	V_{SINE}	$R_{\text{SINE}} = 100\text{k}\Omega$	0.2	0.22	-	$\times V_{\text{SUPPLY}}$
THD	THD	$R_S = 1\text{M}\Omega$, Note 7	-	2.0	5.0	%
THD Adjusted			-	1.5	-	%

Note 4. $V_{\text{SUPPLY}} = 20\text{V}$; R_A and $R_B = 10\text{k}\Omega$, $f = 10\text{kHz}$ nominal; can be extended 1000 to 1.

Note 5. Pin7 and Pin8 connected, $V_{\text{SUPPLY}} = \pm 10\text{V}$.

Note 6. Not tested, typical value for design purposes only.

Note 7. $82\text{k}\Omega$ connected between Pin11 and Pin12, Triangle Duty Cycle set at 50%. (Use R_A and R_B)

Test Conditions:

Parameter	R_A	R_B	R_L	C	SW_1	MEASURE
Supply Current	$10\text{k}\Omega$	$10\text{k}\Omega$	$10\text{k}\Omega$	3.3nF	Closed	Current into Pin6
Sweep FM Range (Note 8)	$10\text{k}\Omega$	$10\text{k}\Omega$	$10\text{k}\Omega$	3.3nF	Open	Frequency at Pin9
Frequency Drift with Temperature	$10\text{k}\Omega$	$10\text{k}\Omega$	$10\text{k}\Omega$	3.3nF	Closed	Frequency at Pin3
Frequency Drift with Supply Voltage (Note 9)	$10\text{k}\Omega$	$10\text{k}\Omega$	$10\text{k}\Omega$	3.3nF	Closed	Frequency at Pin9
Output Amplitude (Note 10)						
Sine	$10\text{k}\Omega$	$10\text{k}\Omega$	$10\text{k}\Omega$	3.3nF	Closed	Pk-Pk Output at Pin2
Triangle	$10\text{k}\Omega$	$10\text{k}\Omega$	$10\text{k}\Omega$	3.3nF	Closed	Pk-Pk Output at Pin3
Leakage Current (OFF) (Note 11)	$10\text{k}\Omega$	$10\text{k}\Omega$	-	3.3nF	Closed	Current into Pin9
Saturation Voltage (ON) (Note 11)	$10\text{k}\Omega$	$10\text{k}\Omega$	-	3.3nF	Closed	Output (Low) at Pin9
Rise and Fall Times (Note 6)	$10\text{k}\Omega$	$10\text{k}\Omega$	$4.7\text{k}\Omega$	3.3nF	Closed	Waveform at Pin9
Duty Cycle Adjust (Note 6)						
Max	$50\text{k}\Omega$	$-1.6\text{k}\Omega$	$10\text{k}\Omega$	3.3nF	Closed	Waveform at Pin9
Min	$-25\text{k}\Omega$	$50\text{k}\Omega$	$10\text{k}\Omega$	3.3nF	Closed	Waveform at Pin9
Triangle Waveform Linearity	$10\text{k}\Omega$	$10\text{k}\Omega$	$10\text{k}\Omega$	3.3nF	Closed	Waveform at Pin3
Total Harmonic Distortion	$10\text{k}\Omega$	$10\text{k}\Omega$	$10\text{k}\Omega$	3.3nF	Closed	Waveform at Pin2

Note 6. Not tested, typical value for design purposes only.

Note 8. The high and low frequencies can be obtained by connecting Pin8 to Pin7 (f_{HI}) and then connecting Pin8 to Pin6 (f_{LO}). Otherwise apply Sweep Voltage at Pin8 ($2/3 V_{\text{SUPPLY}} + 2\text{V}$) $\leq V_{\text{SWEEP}} \leq V_{\text{SUPPLY}}$ where V_{SUPPLY} is the total supply voltage (Pin8 should vary between 5.3V and 10V with respect to GND).

Note 9. $10\text{V} \leq V_+ \leq 30\text{V}$, or $\pm 5\text{V} \leq V_{\text{SUPPLY}} \leq \pm 15\text{V}$.

Note 10. Output Amplitude is tested under static conditions by forcing Pin10 to +5V then to -5V.

Note 11. Oscillation can be halted by forcing Pin10 to +5V then to -5V.

Application Information:

An external capacitor C is charged and discharged by two current sources. Current source #2 is switched on and off by a flip-flop, while current source #1 is on continuously. Assuming that the flip-flop is in a state such that current source #2 is off, and the capacitor is charged with a current I, the voltage across the capacitor rises linearly with time. When this voltage reaches the level of comparator #1 (set at 2/3 of the supply voltage), the flip-flop is triggered, changes states, and releases current source #2. This current source normally carries a current 2I, thus the capacitor is discharged with a net-current I and the voltage across it drops linearly with time. When it has reached the level of comparator #2 (set at 1/3 of the supply voltage), the flip-flop is triggered into its original state and the cycle starts again.

Four waveforms are readily obtainable from this basic generator circuit. With the current source set at I and 2I respectively, the charge and discharge times are equal. Thus a triangle waveform is created across the capacitor and the flip-flop produces a square wave. Both waveforms are fed to buffer stages and are available at Pin3 and Pin9.

The levels of the current sources can, however, be selected over a wide range with two external resistors. Therefore, with the two currents set at values different from I and 2I, an asymmetrical sawtooth appears at Pin3 and pulses with a duty cycle from less than 1% to greater than 99% are available at Pin9.

The sine wave is created by feeding the triangle wave into a nonlinear network (sine converter). This network provides a decreasing shunt impedance as the potential of the triangle moves toward the two extremes.

Pin Connection Diagram

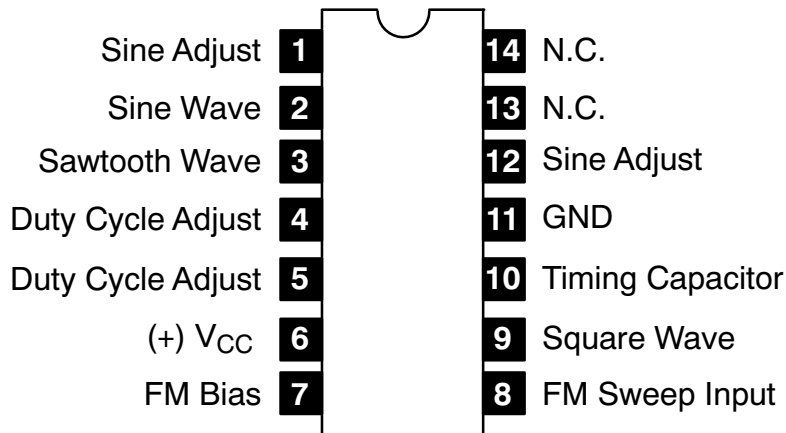

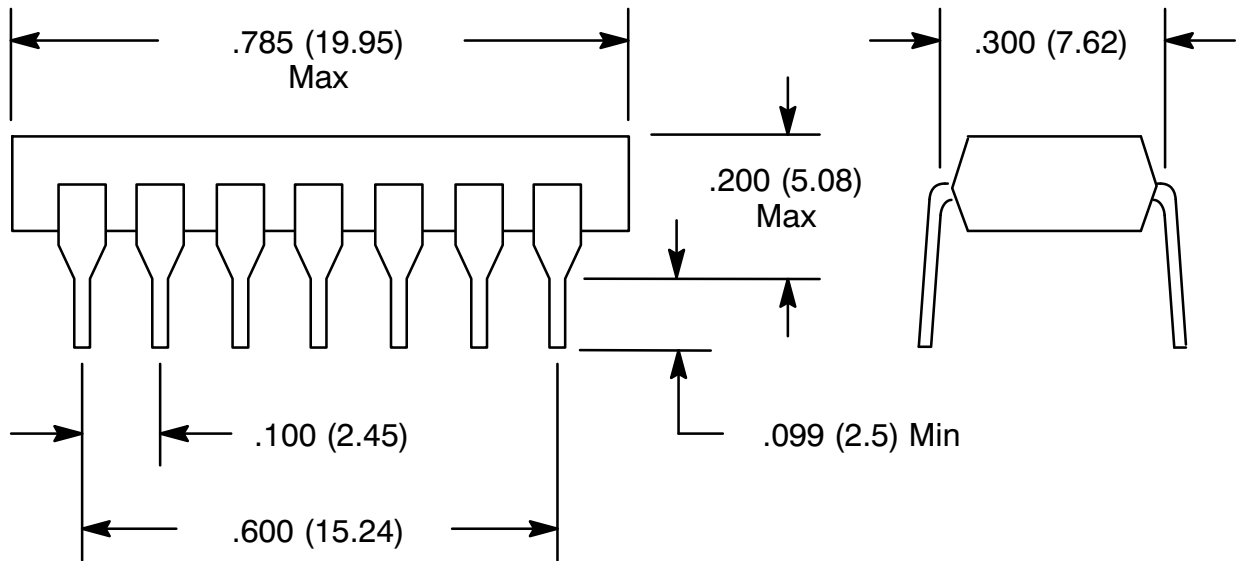
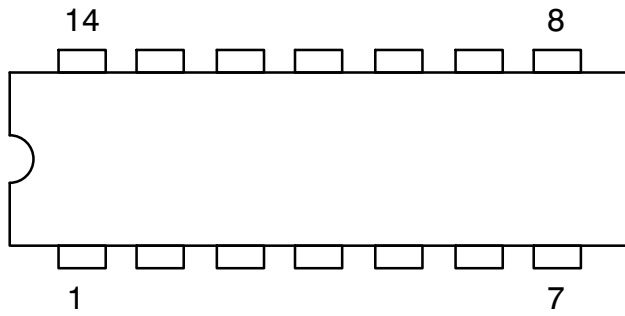

Looking for pricing, stock, or lifecycle information?

Click below to explore more details on WIN SOURCE:

 [View NTE864 on WIN SOURCE](#)

 [NTE Information](#)

Optimize Your Supply Chain with WIN SOURCE Solutions

-  Global Sourcing Solution
-  Obsolete Management
-  Cost Control Management
-  Shortage Management
-  Alternative Solution
-  Excess Inventory Management