

P5Q Serial Phase Change Memory (PCM)

Features

- SPI bus compatible serial interface
- Maximum clock frequency
 - 66 MHz (0°C to +70°C)
 - 33 MHz (–30°C to +85°C)
- 2.7V to 3.6V single supply voltage
- Supports legacy SPI protocol and new quad I/O or dual I/O SPI protocol
- Quad I/O frequency of 50 MHz, resulting in an equivalent clock frequency up to 200 MHz
- Dual I/O frequency of 66 MHz, resulting in an equivalent clock frequency up to 132 MHz
- Continuous READ of entire memory via single instruction:
 - Quad and dual output fast read
 - Quad and dual input fast program
- Uniform 128Kb sectors (Flash emulation)
- WRITE operations
 - 128Kb sectors ERASE (emulated)
 - Legacy Flash PAGE PROGRAM
 - Bit-alterable page WRITES
 - PAGE PROGRAM on all 1s (PRESET WRITES)
- Write protections: protected area size defined by four nonvolatile bits (BP0, BP1, BP2, and BP3)
- JEDEC-standard two-byte signature (DA18h)
- 128Mb density with SOIC16 package
- More than 1,000,000 WRITE cycles
- Phase change memory (PCM)
 - Chalcogenide phase change storage element
 - Bit-alterable WRITE operation

Table of Contents

Features	1
Functional Description	6
Product Features	6
Signal Names	8
Signal Descriptions	8
Serial Data Input (D/DQ0)	8
Serial Data Output (Q/DQ1)	8
Serial Clock (C)	8
Chip Select (S#)	9
Hold (HOLD#/DQ3)	9
Write Protect (W#/DQ2)	9
VCC Supply Voltage	9
VSS Ground	9
SPI Modes	9
Operating Features	12
PAGE PROGRAM	12
DUAL INPUT FAST PROGRAM	12
QUAD INPUT FAST PROGRAM	12
SECTOR ERASE and BULK ERASE	12
Polling During a WRITE, PROGRAM, or ERASE Cycle	13
Active Power and Standby Power	13
Status Register	13
Protocol-Related Protections	13
Hold Condition	14
Memory Organization	15
Instructions	17
WRITE ENABLE (WREN)	18
WRITE DISABLE (WRDI)	18
READ IDENTIFICATION (RDID)	19
READ STATUS REGISTER (RDSR)	20
WRITE STATUS REGISTER (WRSR)	21
Read Data Bytes (READ)	23
Read Data Bytes at Higher Speed (FAST_READ)	24
DUAL OUTPUT FAST READ (DOFR)	25
QUAD OUTPUT FAST READ (QOFR)	26
PAGE PROGRAM (PP)	27
DUAL INPUT FAST PROGRAM (DIFP)	28
QUAD INPUT FAST PROGRAM (QIFP)	29
SECTOR ERASE (SE)	31
BULK ERASE (BE)	31
Power-Up and Power-Down	32
Initial Delivery State	33
Maximum Ratings	34
DC and AC Characteristics	34
Operating Conditions	34
Endurance Specifications	34
AC Measurement Conditions	35
Capacitance	36
DC Characteristics	36
AC Characteristics	37
Package Dimensions	40



Ordering Information.....41

List of Figures

Figure 1:	Logic Diagram	7
Figure 2:	SO16 Connections	7
Figure 3:	Bus Master and Memory Devices on the SPI Bus	10
Figure 4:	SPI Modes Supported	11
Figure 5:	Hold Condition Activation	15
Figure 6:	WRITE ENABLE (WREN) Instruction Sequence	18
Figure 7:	WRITE DISABLE (WRDI) Instruction Sequence	19
Figure 8:	READ IDENTIFICATION (RDID) Instruction Sequence and Data-Out Sequence	20
Figure 9:	READ STATUS REGISTER (RDSR) Instruction Sequence and Data-Out Sequence	21
Figure 10:	WRITE STATUS REGISTER (WRSR) Instruction Sequence	22
Figure 11:	READ DATA BYTES (READ) Instruction Sequence and Data-Out Sequence	24
Figure 12:	FAST_READ Instruction Sequence and Data-Out Sequence	25
Figure 13:	DUAL OUTPUT FAST READ Instruction Sequence	26
Figure 14:	QUAD OUTPUT FAST READ Instruction Sequence	27
Figure 15:	PP Instruction Sequence	28
Figure 16:	DIFP Instruction Sequence	29
Figure 17:	QIFP Instruction Sequence	30
Figure 18:	SE Instruction Sequence	31
Figure 19:	BE Instruction Sequence	32
Figure 20:	Power-Up Timing	33
Figure 21:	AC Measurement I/O Waveform	35
Figure 22:	Serial Input Timing	38
Figure 23:	Write Protect Setup and Hold Timing During WRSR when SRWD = 1	38
Figure 24:	Hold Timing	39
Figure 25:	Output Timing	39
Figure 26:	SO16 Wide – 16-Lead Plastic Small-Outline, 300 Mils Body Width, Package Outline	40

List of Tables

Table 1:	Signal Names	8
Table 2:	Sizes of Protected Areas	14
Table 3:	Memory Organization	15
Table 4:	Organization of Super Page Regions	17
Table 5:	Instruction Set	17
Table 6:	READ IDENTIFICATION (RDID) Data-Out Sequence	19
Table 7:	Status Register Format	20
Table 8:	Protection Modes	23
Table 9:	Power-Up Timing and V_{WI} Threshold	33
Table 10:	Absolute Maximum Ratings	34
Table 11:	Operating Conditions	34
Table 12:	Endurance Specifications	34
Table 13:	AC Measurement Conditions	35
Table 14:	Capacitance ¹	36
Table 15:	DC Characteristics	36
Table 16:	AC Characteristics	37
Table 17:	SO16 wide – Wide - 16-Lead Plastic Small-Outline, 300 Mils Body Width, Mechanical Data	40
Table 18:	Active Line Item Ordering Table	41

Functional Description

P5Q serial phase change memory (PCM) is nonvolatile memory that stores information through a reversible structural phase change in a chalcogenide material. The material exhibits a change in material properties, both electrical and optical, when changed from the amorphous (disordered) to the polycrystalline (regularly ordered) state. In the case of PCM, information is stored via the change in resistance that the chalcogenide material experiences when undergoing a phase change. The material also changes optical properties after experiencing a phase change, a characteristic that has been successfully mastered for use in current rewritable optical storage devices, such as rewritable CDs and DVDs.

The P5Q serial PCM storage element consists of a thin film of chalcogenide contacted by a resistive heating element. In PCM, the phase change is induced in the memory cell by highly localized Joule heating caused by an induced current at the material junction. During a WRITE operation, a small volume of the chalcogenide material is made to change phase. The phase change is a reversible process and is modulated by the magnitude of injected current, the applied voltage, and the duration of the heating pulse.

Unlike other proposed alternative memories, P5Q serial PCM technology uses a conventional CMOS process with the addition of a few additional layers to form the memory storage element. Overall, the basic memory manufacturing process used to make PCM is less complex than that of NAND, NOR, or DRAM.

P5Q serial PCM combines the benefits of traditional floating gate Flash, both NOR-type and NAND-type, with some of the key attributes of RAM and EEPROM. Like NOR Flash and RAM technology, PCM offers fast random access times. Like NAND Flash, PCM has the ability to write moderately fast, and like RAM and EEPROM, PCM supports bit-alterable WRITES (overwrite). Unlike Flash, no separate erase step is required to change information from 0 to 1 and 1 to 0. Unlike RAM, however, the technology is nonvolatile with data retention compared with NOR Flash.

Product Features

P5Q serial PCM devices have 128Mb (16Mb x 8Mb) SPI phase change memory with advanced write protection mechanisms, accessed by a high-speed, SPI-compatible bus. The memory can be programmed from 1 to 64 bytes at a time using the PAGE PROGRAM, DUAL INPUT FAST PROGRAM, and QUAD INPUT FAST PROGRAM instructions. It's organized as 128 sectors that are further divided into 1024 pages each (131,072 total pages). For compatibility with Flash memory devices, P5Q serial PCM supports SECTOR ERASE (128Kb sector) and BULK ERASE instructions.

In addition to BULK ERASE instructions, P5Q serial PCM supports four high-performance dual and quad input/output instructions that double or quadruple the transfer bandwidth for READ and PROGRAM operations.

- **DUAL OUTPUT FAST READ (DOFR)** instructions read data up to 66 MHz using both DQ0 and DQ1 pins as outputs.
- **QUAD OUTPUT FAST READ (QOFR)** instructions read data up to 50 MHz using DQ0, DQ1, DQ2(W#), and DQ3(HOLD#) pins as outputs.
- **DUAL INPUT FAST PROGRAM (DIFP)** instructions program data up to 66 MHz using both DQ0 and DQ1 pins as inputs.
- **QUAD INPUT FAST PROGRAM (QIFP)** instructions program data up to 50 MHz using DQ0, DQ1, DQ2(W#), and DQ3(HOLD#) pins as inputs.

PCM P5Q serial PCM can be write protected by software using a mix of volatile and nonvolatile protection features, depending on application needs. The protection granularity is 128Kb (sector granularity).

Figure 1: Logic Diagram

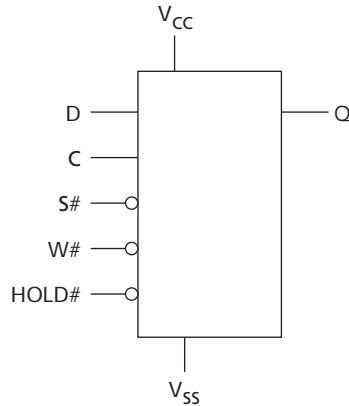
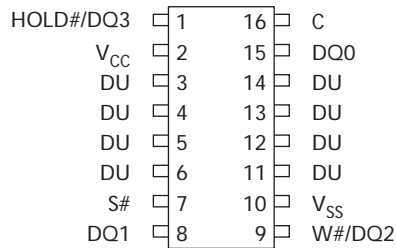

Figure 2: SO16 Connections



- Notes:
1. DU = Do not use. User must float these pins.
 2. See "Package Dimensions" on page 40 for package dimensions and how to identify pins.
 3. For SO8 package solutions, contact your Micron representative.

Signal Names

Table 1: Signal Names

Signal Name	Standard x1 Mode		Dual Mode		Quad Mode	
	Function	Direction	Function	Direction	Function	Direction
C	Serial clock	Input	Serial clock	Input	Serial clock	Input
D (DQ0)	Serial data input	Input	Serial data I/O	I/O ¹	Serial data I/O	I/O ¹
Q (DQ1)	Serial data output	Output	Serial data I/O	I/O ¹	Serial data I/O	I/O ¹
S#	Chip select	Input	Chip select	Input	Chip select	Input
W# (DQ2)	Write protect	Input	Write Protect	Input	Serial data I/O	I/O ¹
HOLD# (DQ3)	Hold	Input	Hold	Input	Serial data I/O	I/O ¹
V _{CC}	Supply voltage					
V _{SS}	Ground					

Notes: 1. Serves as an input during DUAL INPUT FAST PROGRAM (DIFP) and QUAD INPUT FAST PROGRAM (QIFP) instructions. Serves as an output during DUAL OUTPUT FAST READ (DOFR) and QUAD OUTPUT FAST READ (QOFR) instructions.

Signal Descriptions

Serial Data Input (D/DQ0)

The serial data input signal (D/DQ0) transfers data serially into the device and receives instructions, addresses, and the data to be programmed. Values are latched on the rising edge of serial clock (C).

During the DUAL OUTPUT FAST READ (DOFR) and QUAD OUTPUT FAST READ (QOFR) instructions, this pin is an output (DQ0). Data is shifted out on the falling edge of the C.

Serial Data Output (Q/DQ1)

The serial data output signal (Q/DQ1) transfers data serially out of the device. Data is shifted out on the falling edge of C.

During the DIFP and QIFP instructions, this pin is used for data input (DQ1). It is latched on the rising edge of the C.

During the DOFR and QOFR instructions, this pin is used as data output (DQ1). Data is shifted out on the falling edge of C.

Serial Clock (C)

The serial clock input signal (C) provides the timing of the serial interface. Instructions, addresses, or data present at DQ0 are latched on the rising edge of C. Data on DQ1 changes after the falling edge of C.

Chip Select (S#)

When a chip select signal (S#) is HIGH, the device is deselected and DQ1 is High-Z. Unless an internal PROGRAM, ERASE, or WRITE STATUS REGISTER cycle is in progress, the device will be in standby power mode. Driving S# LOW enables the device, placing it in active power mode.

After power-up, a falling edge on S# is required prior to the start of any instruction.

Hold (HOLD#/DQ3)

The hold signal (HOLD#) pauses any serial communications with the device without deselecting the device. During the HOLD condition, DQ1 is High-Z, and DQ0 and C are “Don’t Care.” To start the hold condition, the device must be selected with S# driven LOW.

During QIFP instructions, this pin is used for data input (DQ3). It is latched on the rising edge of the C. During QOFR instructions, this pin is used for data output (DQ3). Data is shifted out on the falling edge of C.

Write Protect (W#/DQ2)

The write protect input signal (W#,DQ#2) freezes the size of the area of memory that is protected against program or erase instructions (as specified by the values in the BP3, BP2, BP1, and BP0 bits of the status register).

During QIFP instructions, this pin is used for data input (DQ2). It is latched on the rising edge of the C. During QOFR instructions, this pin is used for data output (DQ2). Data is shifted out on the falling edge of C.

V_{CC} Supply Voltage

V_{CC} is the supply voltage.

V_{SS} Ground

V_{SS} is the reference for the V_{CC} supply voltage.

SPI Modes

P5Q serial PCM devices can be driven by a microcontroller with its SPI peripheral running in either of these two modes:

- CPOL = 0, CPHA = 0
- CPOL = 1, CPHA = 1

For these two modes, input data is latched in on the rising edge of C, and output data is available from the falling edge of C. The difference between the two modes, as shown in Figure 4 on page 11, is the clock polarity when the bus master is in standby mode and not transferring data.

- C remains at 0 for (CPOL = 0, CPHA = 0)
- C remains at 1 for (CPOL = 1, CPHA = 1)

Figure 3 on page 10 is an example of three devices connected to an MCU on an SPI bus. Only one device is selected at a time, so only one device drives the serial data output (DQ1) line at a time; the other devices are High-Z. Resistors R (shown in Figure 3 on page 10) ensure that the P5Q serial PCM is not selected if the bus master leaves the S#

line in the High-Z state. Because the bus master may enter a state where all inputs/ outputs are in High-Z at the same time (for example, when the bus master is reset), the clock line (C) must be connected to an external pull-down resistor. As a result, when all inputs/outputs become High-Z, the S# line is pulled HIGH, while the C line is pulled LOW. This ensures that S# and C do not become HIGH at the same time and that the t_{SHCH} requirement is met.

The typical value of R is 100k Ω , assuming that the time constant $R \times C_p$ (C_p = parasitic capacitance of the bus line) is shorter than the time during which the bus master leaves the SPI bus in High-Z.

Figure 3: Bus Master and Memory Devices on the SPI Bus

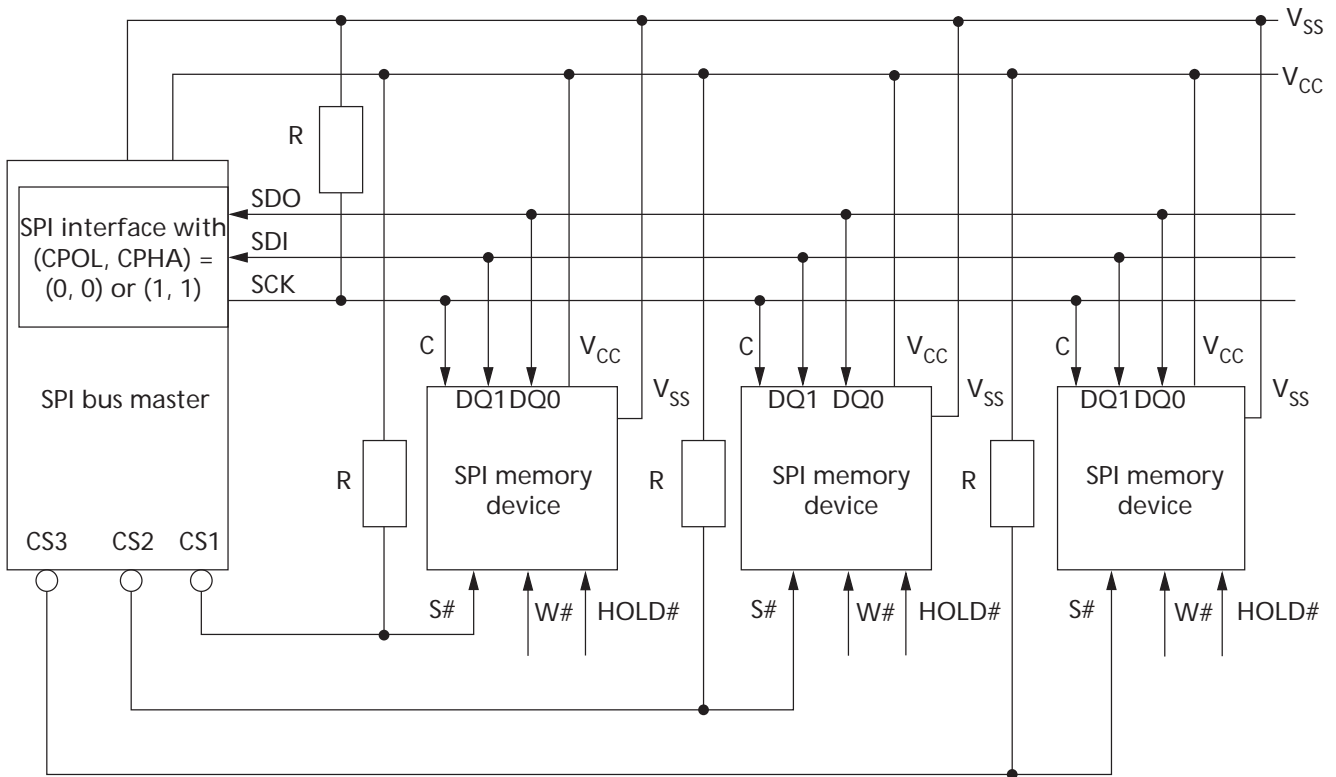

Notes: 1. W# and (HOLD# signals should be driven HIGH or LOW, as appropriate.

Figure 4: SPI Modes Supported

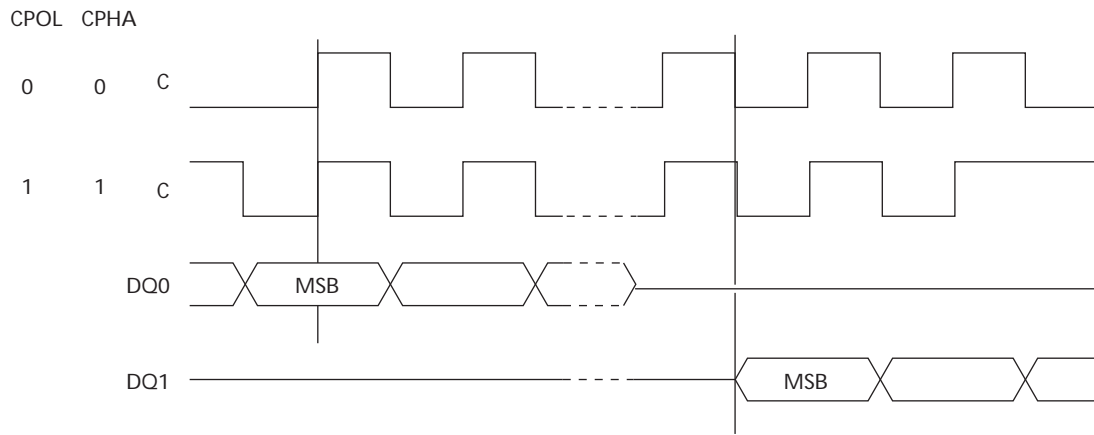

Operating Features

To better understand operating features of the P5Q serial PCM device, refer to the following definitions:

- **PROGRAM:** P5Q serial PCM devices write only 0s of the user data to the array and treat 1s as data masks. This is similar to programming on a floating gate Flash device.
- **Bit-alterable WRITE:** P5Q serial PCM devices write both 0s and 1s of the user data to the array.
- **PROGRAM on all 1s:** Only 0s are written to the array, and 1s are treated as data masks. PROGRAM on all 1s also requires that the entire page being written be previously set to all 1s. PROGRAM on all 1s is also referred to as PRESET WRITE.

PAGE PROGRAM

To PROGRAM/WRITE one data byte, two instructions are required: WRITE ENABLE (WREN), which is one byte; and a PAGE PROGRAM (PP) sequence, which consists of four bytes plus data byte. This is followed by the internal PROGRAM cycle (of duration t_{PP}).

To spread this overhead, the PP instruction allows up to 64 bytes to be programmed/written at a time, provided that they lie in consecutive addresses on the same page of memory.

For optimized timings, it is recommended to use the PP instruction to program all consecutive targeted bytes in a single sequence versus using several PP sequences with each containing only a few bytes (see “PAGE PROGRAM (PP)” on page 27 and Table 16 on page 37).

DUAL INPUT FAST PROGRAM

The DUAL INPUT FAST PROGRAM (DIFP) instruction makes it possible to PROGRAM/WRITE up to 64 bytes using two input pins at the same time.

For optimized timings, it is recommended to use the DIFP instruction to program all consecutive targeted bytes in a single sequence rather than using several DIFP sequences each containing only a few bytes.

QUAD INPUT FAST PROGRAM

The QUAD INPUT FAST PROGRAM (QIFP) instruction makes it possible to PROGRAM/WRITE up to 64 bytes using four input pins at the same time.

For optimized timings, use the QIFP instruction to program all consecutive targeted bytes in a single sequence rather than several QIFP sequences each containing only a few bytes.

SECTOR ERASE and BULK ERASE

A sector can be erased to all 1s (FFh) at a time using the SECTOR ERASE (SE) instruction. The entire memory can be erased using the BULK ERASE (BE) instruction. This starts an internal ERASE cycle (of duration t_{SE} or t_{BE}).

The ERASE instruction must be preceded by a WREN instruction.

Polling During a WRITE, PROGRAM, or ERASE Cycle

Additional improvements in the time to WRSR, PP, DIFP, QIFP, or ERASE (SE or BE) can be achieved by not waiting for the worst case delay (t_W , t_{PP} , t_{SMEN} , t_{SMEX} , t_{SE} , or t_{BE}). The write in progress (WIP) bit is provided in the status register so that the application program can monitor its value, polling it to establish when the previous WRITE cycle, PROGRAM cycle, or ERASE cycle is complete.

Active Power and Standby Power

When S# is LOW, the device is selected and is in the active power mode. When S# is HIGH, the device is deselected, but could remain in the active power mode until all internal cycles have completed (PROGRAM, ERASE, WRITE STATUS REGISTER). The device then goes in to the standby power mode. The device consumption drops to I_{CC1} .

Status Register

The status register contains a number of status and control bits that can be read or set (as appropriate) by specific instructions. See “READ STATUS REGISTER (RDSR)” on page 20 for a detailed description of the status register bits.

Protocol-Related Protections

The environments where nonvolatile memory devices are used can be very noisy, but SPI devices cannot operate correctly in the presence of excessive noise. To help combat this, the P5Q serial PCM features the following data protection mechanisms:

- Power on reset and an internal timer (t_{PUW}) can provide protection against inadvertent changes while the power supply is outside the operating specification.
- PROGRAM, ERASE, and WRITE STATUS REGISTER are checked to ensure they consist of a number of clock pulses that is a multiple of eight before they are accepted for execution.
- All instructions that modify data must be preceded by a WREN instruction to set the WEL bit. This bit is returned to its reset state by the following events:
 - Power-up
 - WRDI instruction completion
 - WRSR instruction completion
 - PP instruction completion
 - DIFP instruction completion
 - QIFP instruction completion
 - SE instruction completion
 - BE instruction completion
- The block protect bits and top/bottom bit enable part of the memory to be configured as read-only. This is the software protect mode (SPM).
- The W# signal enables the block protect bits (BP3, BP2, BP1, BP0), top/bottom (TB) bit, and status register write disable (SRWD) bit to be protected. This is the hardware protected mode (HPM).

Table 2: Sizes of Protected Areas

Status Register Contents					Memory Content	
TB Bit	BP Bit 3	BP Bit 2	BP Bit 1	BP Bit 0	Protected Area	Unprotected Area
0	0	0	0	0	None	All sectors ¹ (sectors 0 to 127)
0	0	0	0	1	Upper 128 (sector 127)	Sectors 0 to 126
0	0	0	1	0	Upper 64 (sectors 126 to 127)	Sectors 0 to 125
0	0	0	1	1	Upper 32 (sectors 124 to 127)	Sectors 0 to 123
0	0	1	0	0	Upper 16 (sectors 120 to 127)	Sectors 0 to 119
0	0	1	0	1	Upper 8 (sectors 112 to 127)	Sectors 0 to 111
0	0	1	1	0	Upper quarter (sectors 96 to 127)	Sectors 0 to 95
0	0	1	1	1	Upper half (sectors 64 to 127)	Sectors 0 to 63
0	1	X ²	X ²	X ²	All sectors (sectors 0 to 127)	None
1	0	0	0	0	None	All sectors ¹ (sectors 0 to 127)
1	0	0	0	1	Lower 128 (sector 0)	Sectors 1 to 127
1	0	0	1	0	Lower 64 (sectors 0 to 1)	Sectors 2 to 127
1	0	0	1	1	Lower 32 (sectors 0 to 3)	Sectors 4 to 127
1	0	1	0	0	Lower 16 (sectors 0 to 7)	Sectors 8 to 127
1	0	1	0	1	Lower 8 (sectors 0 to 15)	Sectors 16 to 127
1	0	1	1	0	Lower 4 (sectors 0 to 31)	Sectors 32 to 127
1	0	1	1	1	Lower half (sectors 0 to 63)	Sectors 64 to 127
1	1	X ²	X ²	X ²	All sectors (sectors 0 to 127)	None

- Notes:
1. The device is ready to accept a BULK ERASE instruction if all block protect bits (BP3, BP2, BP1, BP0) are 0.
 2. X can be 0 or 1.

Hold Condition

The Hold (HOLD#) signal is used to pause any serial communications with the device without resetting the clocking sequence. However, taking this signal LOW does not terminate any WRITE STATUS REGISTER, PROGRAM, or ERASE cycle that is currently in progress.

To enter the hold condition, the device must be selected, with S# LOW. The hold condition starts on the falling edge of the HOLD# signal, provided that this coincides with C being LOW (as shown in Figure 5 on page 15). The hold condition ends on the rising edge of the HOLD# signal, provided that this coincides with C being LOW.

If the falling edge does not coincide with C being LOW, the hold condition starts after the next time C goes LOW. Similarly, if the rising edge does not coincide with C being LOW, the hold condition ends after C next goes LOW (as shown in Figure 5 on page 15).

During the hold condition, DQ1 is High-Z, and DQ0 and C are “Don’t Care.”

Normally, the device is kept selected, with S# driven LOW, for the whole duration of the hold condition. This is to ensure that the state of the internal logic remains unchanged from the moment of entering the hold condition.

If S# goes HIGH while the device is in the hold condition, this has the effect of resetting the internal logic of the device. To restart communication with the device, it is necessary to drive HOLD# HIGH, and then to drive S# LOW. This prevents the device from going back to the hold condition.

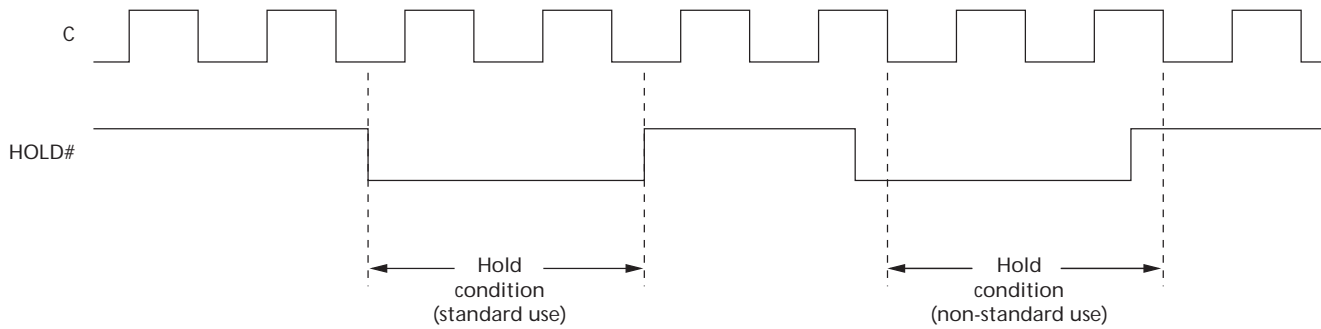
Figure 5: Hold Condition Activation

Memory Organization

The memory is organized as:

- 16,772,216 bytes (8 bits each)
- 8 super page programming regions (16 sectors each)
- 128 sectors (128Kb each)
- 262,144 pages (64 bytes each)

Each page can be individually programmed (bits are programmed from 1 to 0) or written (bit alterable: 1 can be altered to 0 and 0 can be altered to 1). The device is sector or bulk erasable (bits are erased from 0 to 1).

Table 3: Memory Organization

Sector	Address Range	
127	FE0000	FFFFFF
126	FC0000	FDFFFF
125	FA0000	FBFFFF
124	F80000	F9FFFF
123	F60000	F7FFFF
122	F40000	F5FFFF
121	F20000	F3FFFF
120	F00000	F1FFFF
119	EE0000	EFFFFF
118	EC0000	EDFFFF
117	EA0000	EBFFFF
116	E80000	E9FFFF
115	E60000	E7FFFF
114	E40000	E5FFFF
113	E20000	E3FFFF
112	E00000	E1FFFF
111	DE0000	DFFFFF
110	DC0000	DDFFFF
109	DA0000	DBFFFF
108	D80000	D9FFFF
107	D60000	D7FFFF
106	D40000	D5FFFF
105	D20000	D3FFFF

Sector	Address Range	
102	CC0000	CDFFFF
101	CA0000	CBFFFF
100	C80000	C9FFFF
99	C60000	C7FFFF
98	C40000	C5FFFF
97	C20000	C3FFFF
96	C00000	C1FFFF
95	BE0000	BFFFFFFF
94	BC0000	BDFFFF
93	BA0000	BBFFFF
92	B80000	B9FFFF
91	B60000	B7FFFF
90	B40000	B5FFFF
89	B20000	B3FFFF
88	B00000	B1FFFF
87	AE0000	AFFFFFFF
86	AC0000	ADFFFF
85	AA0000	ABFFFF
84	A80000	A9FFFF
83	A60000	A7FFFF
82	A40000	A5FFFF
81	A20000	A3FFFF
80	A00000	A1FFFF

Table 3: Memory Organization (continued)

Sector	Address Range		Sector	Address Range	
104	D00000	D1FFFF	79	9E0000	9FFFFFF
103	CE0000	CFFFFFF	78	9C0000	9DFFFFFF
77	9A0000	9BFFFFFF	42	540000	55FFFFFF
76	980000	99FFFFFF	41	520000	53FFFFFF
75	960000	97FFFFFF	40	500000	51FFFFFF
74	940000	95FFFFFF	39	4E0000	4FFFFFF
73	920000	93FFFFFF	38	4C0000	4DFFFFFF
72	900000	91FFFFFF	37	4A0000	4BFFFFFF
71	8E0000	8FFFFFF	36	480000	49FFFFFF
70	8C0000	8DFFFFFF	35	460000	47FFFFFF
69	8A0000	8BFFFFFF	34	440000	45FFFFFF
68	880000	89FFFFFF	33	420000	43FFFFFF
67	860000	87FFFFFF	32	400000	41FFFFFF
66	840000	85FFFFFF	31	3E0000	3FFFFFF
65	820000	83FFFFFF	30	3C0000	3DFFFFFF
64	800000	81FFFFFF	29	3A0000	3BFFFFFF
63	7E0000	7FFFFFF	28	380000	39FFFFFF
62	7C0000	7DFFFFFF	27	360000	37FFFFFF
61	7A0000	7BFFFFFF	26	340000	35FFFFFF
60	780000	79FFFFFF	25	320000	33FFFFFF
59	760000	77FFFFFF	24	300000	31FFFFFF
58	740000	75FFFFFF	23	2E0000	2FFFFFF
57	720000	73FFFFFF	22	2C0000	2DFFFFFF
56	700000	71FFFFFF	21	2A0000	2BFFFFFF
55	6E0000	6FFFFFF	20	280000	29FFFFFF
54	6C0000	6DFFFFFF	19	260000	27FFFFFF
53	6A0000	6BFFFFFF	18	240000	25FFFFFF
52	680000	69FFFFFF	17	220000	23FFFFFF
51	660000	67FFFFFF	16	200000	21FFFFFF
50	640000	65FFFFFF	15	1E0000	1FFFFFF
49	620000	63FFFFFF	14	1C0000	1DFFFFFF
48	600000	61FFFFFF	13	1A0000	1BFFFFFF
47	5E0000	5FFFFFF	12	180000	19FFFFFF
46	5C0000	5DFFFFFF	11	160000	17FFFFFF
45	5A0000	5BFFFFFF	10	140000	15FFFFFF
44	580000	59FFFFFF	9	120000	13FFFFFF
43	560000	57FFFFFF	8	100000	11FFFFFF
7	0E0000	0FFFFFF	3	060000	07FFFFFF
6	0C0000	0DFFFFFF	2	040000	05FFFFFF
5	0A0000	0BFFFFFF	1	020000	03FFFFFF
4	080000	09FFFFFF	0	000000	01FFFFFF

Table 4: Organization of Super Page Regions

Programming Region	Sectors	Address Range
7	112 to 127	E00000 to FFFFFFFF
6	96 to 111	C00000 to DFFFFFFF
5	80 to 95	A00000 to BFFFFFFF
4	64 to 79	800000 to 9FFFFFFF
3	48 to 63	600000 to 7FFFFFFF
2	32 to 47	400000 to 5FFFFFFF
1	16 to 31	200000 to 3FFFFFFF
0	0 to 15	000000 to 1FFFFFFF

Instructions

All instructions, addresses, and data are shifted in and out of the device, most significant bit first.

Serial data input DQ0 is sampled on the first rising edge of C after S# is driven LOW. Then, the one-byte instruction code must be shifted in to the device, most significant bit first, on serial data input DQ0, each bit being latched on the rising edges of C. The instruction set is listed in Table 5 on page 17.

Every instruction sequence starts with a one-byte instruction code. Depending on the instruction, this might be followed by address bytes, data bytes, both, or none.

In the case of read data bytes (READ), read data bytes at higher speed (FAST_READ), DOFR, QOFR, RDSR, or READ IDENTIFICATION (RDID) instruction, the shifted-in instruction sequence is followed by a data-out sequence. S# can be driven HIGH after any bit of the data-out sequence is being shifted out.

In the case of a PP, DIFP, QIFP, SE, BE, WRSR, WREN, or WRDI, S# must be driven HIGH exactly at a byte boundary; otherwise the instruction is rejected and is not executed. That is, S# must be driven HIGH when the number of clock pulses after S# being driven LOW is an exact multiple of eight.

All attempts to access the memory array during a WRITE STATUS REGISTER cycle, PROGRAM cycle, or ERASE cycle are ignored and the internal WRITE STATUS REGISTER cycle, PROGRAM cycle, ERASE cycle continues unaffected.

Note: Output High-Z is defined as the point where data out is no longer driven.

Table 5: Instruction Set

Instruction	Description	One-Byte Instruction Code		Address Bytes	Dummy Bytes	Data Bytes
WREN	Write enable	0000 0110	06h	0	0	0
WRDI	Write disable	0000 0100	04h	0	0	0
RDID	Read identification	1001 1111	9Fh	0	0	1 to 3
		1001 1110	9Eh	0	0	1 to 3
RDSR	Read status register	0000 0101	05h	0	0	1 to ∞
WRSR	Write status register	0000 0001	01h	0	0	1
READ	Read data bytes	0000 0011	03h	3	0	1 to ∞
FAST_READ	Read data bytes at higher speed	0000 1011	0Bh	3	1	1 to ∞
DOFR	Dual output fast read	0011 1011	3Bh	3	1	1 to ∞

Table 5: Instruction Set (continued)

Instruction	Description	One-Byte Instruction Code		Address Bytes	Dummy Bytes	Data Bytes
		Code	Hex			
QOFR	Quad output fast read	0110 1011	6Bh	3	1	1 to ∞
PP	Page program (legacy program)	0000 0010	02h	3	0	1 to 64
	Page program (bit-alterable write)	0010 0010	22h	3	0	1 to 64
	Page program (on all 1s)	1101 0001	D1h	3	0	1 to 64
DIFP	Dual input fast program (legacy program)	1010 0010	A2h	3	0	1 to 64
	Dual input fast program (bit-alterable write)	1101 0011	D3h	3	0	1 to 64
	Dual input fast program (on all 1s)	1101 0101	D5h	3	0	1 to 64
QIFP	Quad input fast program (legacy program)	0011 0010	32h	3	0	1 to 64
	Quad input fast program (bit-alterable write)	1101 0111	D7h	3	0	1 to 64
	Quad input fast program (on all 1s)	1101 1001	D9h	3	0	1 to 64
SE	Sector erase	1101 1000	D8h	3	0	0
BE	Bulk erase	1100 0111	C7h	0	0	0

WRITE ENABLE (WREN)

The WRITE ENABLE (WREN) instruction sets the WEL bit. The WEL bit must be set prior to every PP, DIFP, SE, BE, or WRSR instruction.

The WREN instruction is entered by driving S# LOW, sending the instruction code, and then driving S# HIGH.

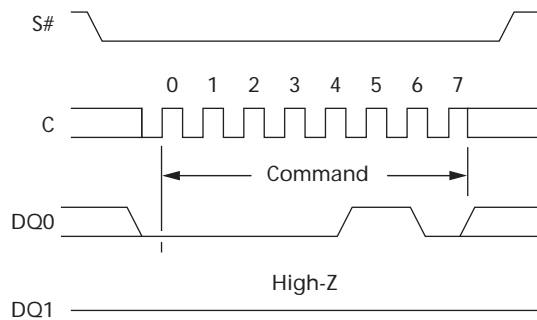
Figure 6: WRITE ENABLE (WREN) Instruction Sequence

WRITE DISABLE (WRDI)

The WRITE DISABLE (WRDI) instruction resets the WEL bit. The WRDI instruction is entered by driving S# LOW, sending the instruction code, and then driving S# HIGH.

The WEL bit is reset under the following conditions:

- Power-up
- WRDI instruction completion
- WRSR instruction completion
- PP instruction completion
- DIFP instruction completion

- QIFP instruction completion
- SE instruction completion
- BE instruction completion

Figure 7: WRITE DISABLE (WRDI) Instruction Sequence

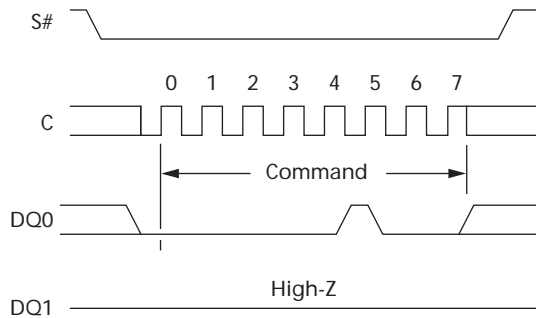

READ IDENTIFICATION (RDID)

The READ IDENTIFICATION (RDID) instruction enables devices to read the device identification data, including manufacturer identification (1 byte) and device identification (2 bytes).

The manufacturer identification is assigned by JEDEC and has the value 20h for Micron. Any RDID instruction while an ERASE or PROGRAM cycle is in progress is not decoded and has no effect on the cycle that is in progress.

The device is first selected by driving S# LOW. Then, the 8-bit instruction code for the instruction is shifted in. After this, the 24-bit device identification stored in the memory will be shifted out on serial data output (DQ1). Each bit is shifted out during the falling edge of C. The instruction sequence is shown in Figure 8 on page 20.

The RDID instruction is terminated by driving S# HIGH at any time during data output. When S# is driven HIGH, the device is put in the standby power mode. After the device is in the standby power mode, the device waits to be selected so that it can receive, decode, and execute instructions.

Table 6: READ IDENTIFICATION (RDID) Data-Out Sequence

Manufacturer Identification	Device identification	
	Memory Type (Upper Byte)	Memory Capacity (Lower Byte)
20h	DAh	18h

Figure 8: READ IDENTIFICATION (RDID) Instruction Sequence and Data-Out Sequence

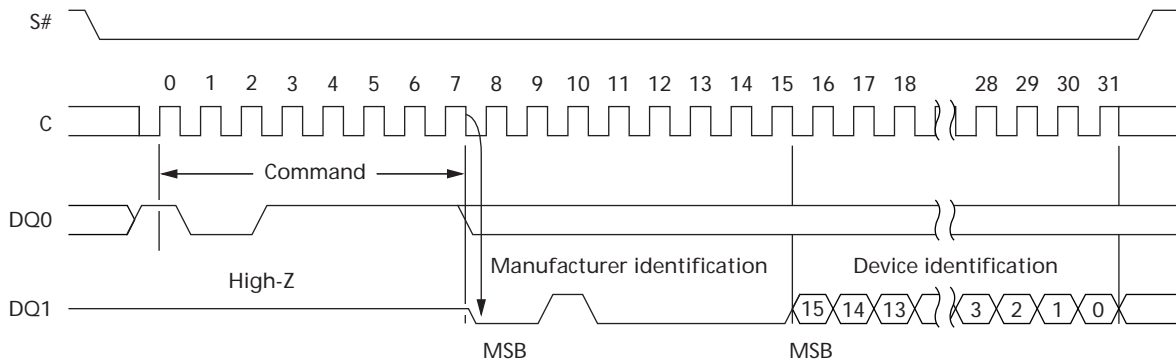

READ STATUS REGISTER (RDSR)

The READ STATUS REGISTER (RDSR) instruction enables the status register to be read. The status register may be read at any time, even while a PROGRAM, ERASE, or WRITE STATUS REGISTER cycle is in progress. When one of these cycles is in progress, it is recommended to check the WIP bit before sending a new instruction to the device. It is also possible to read the status register continuously, as shown in Figure 9 on page 21.

RDSR is the only instruction accepted by the device while a PROGRAM, ERASE, WRITE STATUS REGISTER operation is in progress.

Table 7: Status Register Format

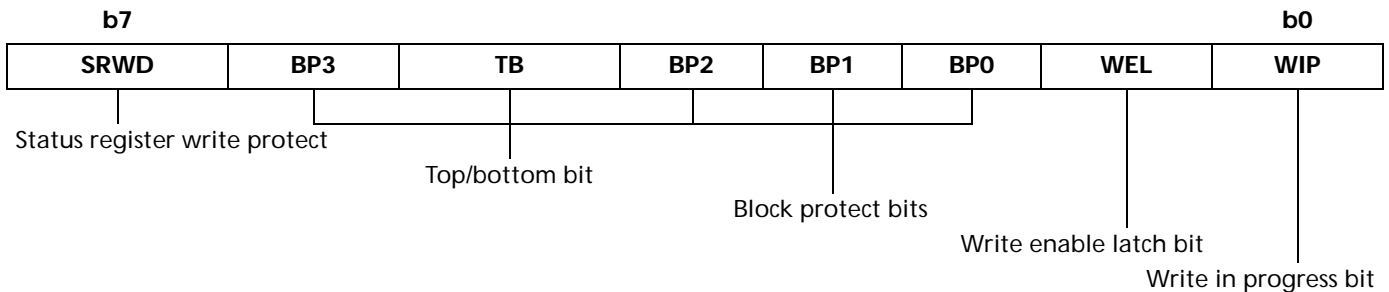

The status and control bits of the status register are described below.

WIP Bit

The write in progress (WIP) bit indicates whether the memory is busy with a WRITE STATUS REGISTER, PROGRAM, or ERASE cycle. When set to 1, one of these cycles is in progress; when reset to 0, none of these cycles is in progress. While WIP is 1, RDSR is the only instruction the device will accept; all other instructions are ignored.

WEL Bit

The write enable latch (WEL) bit indicates the status of the internal write enable latch. When set to 1, the internal write enable latch is set. When it is set to 0, the internal write enable latch is reset, and no WRITE STATUS REGISTER, PROGRAM, or ERASE instruction is accepted.

Block Protect Bits

The block protect bits (BP3, BP2, BP1, BP0) are nonvolatile. They define the size of the area to be software protected against PROGRAM (or WRITE) and ERASE instructions. These bits are written with the WRSR instruction. When one or more of the block protect bits is set to 1, the relevant memory area (as defined in Table 2 on page 14) becomes protected against PP, DIFP, QIFP, and SE instructions. The block protect bits can be written, provided that the hardware protected mode has not been set. The BE instruction is executed if all block protect bits are 0.

Top/Bottom Bit

The top/bottom (TB) bit is nonvolatile. It can be set and reset with the WRSR instruction, provided that the WREN instruction has been issued. The TB bit is used in conjunction with the block protect bits to determine if the protected area defined by the block protect bits starts from the top or the bottom of the memory array.

- When TB bit is reset to 0 (default value), the area protected by the block protect bits starts from the top of the memory array (see Table 2 on page 14)
- When TB bit is set to 1, the area protected by the block protect bits starts from the bottom of the memory array (see Table 2 on page 14).

The TB bit cannot be written when the SRWD bit is set to 1 and the W# pin is driven LOW.

SRWD Bit

The status register write disable (SRWD) bit is operated in conjunction with the W# signal. The SRWD bit and the W# signal allow the device to be put in the hardware protected mode (when the SRWD bit is set to 1 and W# is driven LOW). In this mode, the nonvolatile bits of the status register (SRWD, TB, BP3, BP2, BP1, BP0) become read-only bits and the WRSR instruction is no longer accepted for execution.

Figure 9: READ STATUS REGISTER (RDSR) Instruction Sequence and Data-Out Sequence

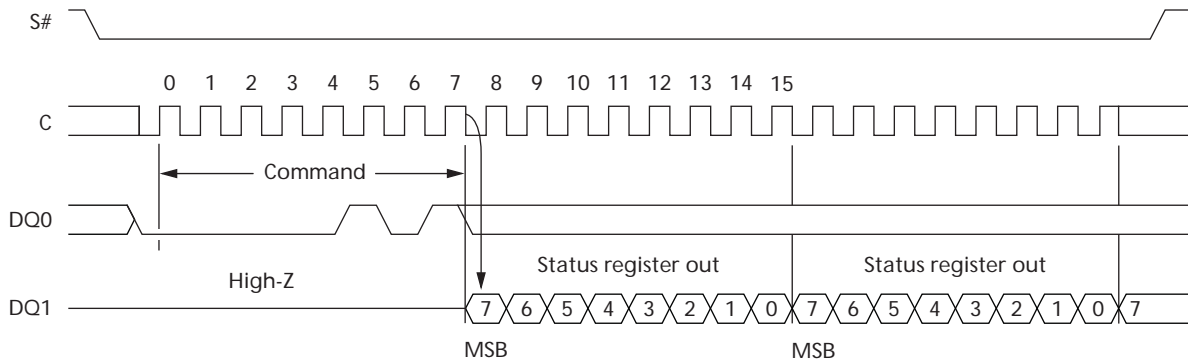

WRITE STATUS REGISTER (WRSR)

The WRITE STATUS REGISTER (WRSR) instruction enables new values to be written to the status register. Before it can be accepted, a WREN instruction must previously have been executed. After the WREN instruction has been decoded and executed, the device sets the WEL.

The WRSR instruction is entered by driving S# LOW, followed by the instruction code and the data byte on serial data input (DQ0). The instruction sequence is shown in Figure 10 on page 22. The WRSR instruction has no effect on B1 and B0 of the status register.

S# must be driven HIGH after the eighth bit of the data byte has been latched in. If not, the WRSR instruction is not executed. As soon as S# is driven HIGH, the self-timed WRITE STATUS REGISTER cycle (whose duration is t^1_W) is initiated. While the WRITE STATUS REGISTER cycle is in progress, the status register may still be read to check the value of the WIP bit. The WIP bit is 1 during the self-timed WRITE STATUS REGISTER cycle, and is 0 when it is completed. When the cycle is completed, the WEL is reset.

The WRSR instruction enables the user to change the values of the block protect bits and to define the size of the area that is to be treated as read-only, as defined in Table 2 on page 14. The WRSR instruction also enables the user to set and reset the SRWD bit in accordance with the W# signal. The SRWD bit and W# signal enable the device to be put in the hardware protected mode (HPM). The WRSR instruction is not executed after the HPM is entered.

RDSR is the only instruction that is accepted while a WRSR operation is in progress; all other instructions are ignored.

Figure 10: WRITE STATUS REGISTER (WRSR) Instruction Sequence

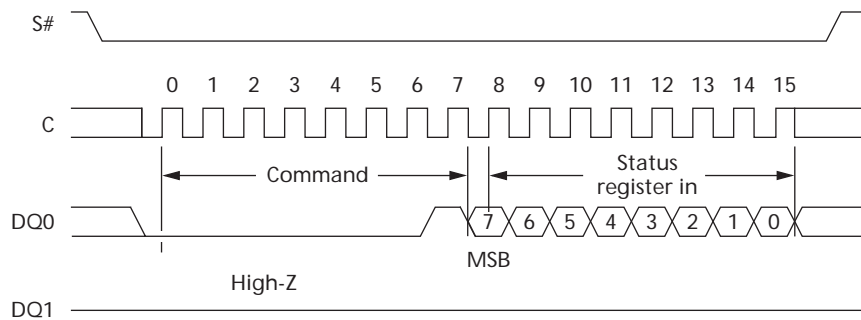

Table 8: Protection Modes

W#	SRWD Bit	Mode	Write Protection of Status Register	Memory Content	
				Protected Area ¹	Unprotected Area ¹
1	0	Software protected (SPM)	Status register is writable (if the WREN instruction has set the WEL bit); the values in the SRWD, TB, BP3, BP2, BP1, and BP0 bits can be changed	Protected against PAGE PROGRAM, SECTOR ERASE, and BULK ERASE	Ready to accept PAGE PROGRAM, and SECTOR ERASE instructions
0	0				
1	1				
0	1	Hardware protected (HPM)	Status register is hardware write protected; the values in the SRWD, TB, BP3, BP2, BP1, and BP0 bits cannot be changed	Protected against PAGE PROGRAM, SECTOR ERASE, and BULK ERASE	Ready to accept PAGE PROGRAM, and SECTOR ERASE instructions

Notes: 1. As defined by the values in the block protect bits (BP3, BP2, BP1, BP0) of the status register, as shown in Table 2 on page 14.

When the SRWD bit of the status register is 0 (its initial delivery state), it is possible to write to the status register, provided that the WEL bit has previously been set by a WREN instruction, regardless of whether W# is driven HIGH or LOW.

When the SRWD bit of the status register is set to 1, two cases need to be considered, depending on the state of W#:

- If W# is driven HIGH, it is possible to write to the status register provided that the WEL bit has previously been set by a WREN instruction.
- If W# is driven LOW, it is not possible to write to the status register even if the WEL bit has previously been set by a WREN instruction (attempts to write to the status register are rejected and are not accepted for execution). As a consequence, all the data bytes in the memory area that are software protected (SPM) by the block protect bits of the status register are also hardware protected against data modification.

Regardless of the order of the two events, the HPM can be entered in one of two ways:

- Set the SRWD bit after driving W# LOW.
- Drive W# LOW after setting the SRWD bit.

The only way to exit HPM after it has been entered is to pull write protect (W#) HIGH.

If write protect (W#) is permanently tied HIGH, HPM can never be activated, and only the software protected mode (SPM), using the block protect bits of the status register, can be used.

Read Data Bytes (READ)

The device is first selected by driving S# LOW. The instruction code for the read data bytes (READ) instruction is followed by a 3-byte address A[23:0], with each bit being latched in during the rising edge of C. Then the memory contents at that address are shifted out on serial data output (DQ1), with each bit being shifted out at a maximum frequency f_R , during the falling edge of C. The instruction sequence is shown in Figure 11 on page 24.

The first byte addressed can be at any location. The address is automatically incremented to the next higher address after each byte of data is shifted out. The whole memory can be read with a single READ instruction. When the highest address is reached, the address counter rolls over to 000000h, enabling the read sequence to be continued indefinitely.

The READ instruction is terminated by driving S# HIGH. S# can be driven HIGH at any time during data output. Any READ instruction, while an ERASE, PROGRAM, or WRITE is in progress, is rejected without having any effects on the cycle that is in progress.

Figure 11: READ DATA BYTES (READ) Instruction Sequence and Data-Out Sequence

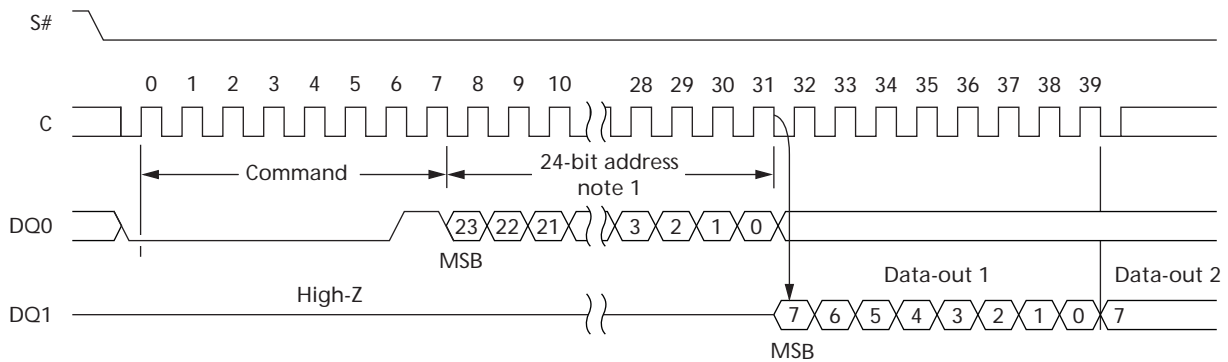

Read Data Bytes at Higher Speed (FAST_READ)

The device is first selected by driving S# LOW. The instruction code for the read data bytes at higher speed (FAST_READ) instruction is followed by a 3-byte address A[23:0] and a dummy byte, with each bit being latched in during the rising edge of C. Then the memory contents at that address are shifted out on serial data output (DQ1) at a maximum frequency f_C , during the falling edge of C. The instruction sequence is shown in Figure 12 on page 25.

The first byte addressed can be at any location. The address is automatically incremented to the next higher address after each byte of data is shifted out. The whole memory can be read with a single FAST_READ instruction. When the highest address is reached, the address counter rolls over to 000000h, enabling the read sequence to be continued indefinitely.

The FAST_READ instruction is terminated by driving S# HIGH. S# can be driven HIGH at any time during data output. While an ERASE, PROGRAM, or WRITE cycle is in progress, any FAST_READ instruction is rejected without having any effects on the cycle that is in progress.

Figure 12: FAST_READ Instruction Sequence and Data-Out Sequence

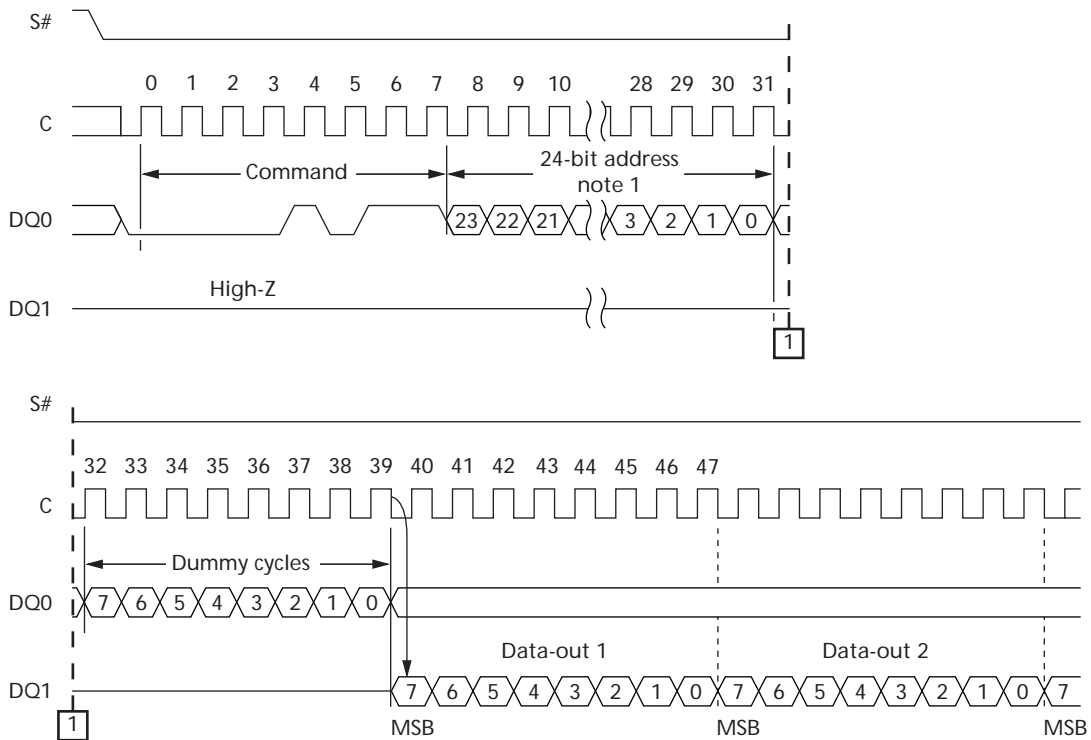

DUAL OUTPUT FAST READ (DOFR)

The DUAL OUTPUT FAST READ (DOFR) instruction is very similar to the FAST_READ instruction, except that the data are shifted out on two pins (DQ0 and DQ1) instead of one. Outputting the data on two pins instead of one doubles the data transfer bandwidth compared to the outputting data using the FAST_READ instruction.

The device is first selected by driving S# LOW. The instruction code for the DOFR instruction is followed by a 3-byte address A[23:0] and a dummy byte, with each bit being latched-in during the rising edge of serial clock (C). Then the memory contents at that address are shifted out on DQ0 and DQ1 at a maximum frequency f_C , during the falling edge of C. The instruction sequence is shown in Figure 13 on page 26.

The first byte addressed can be at any location. The address is automatically incremented to the next higher address after each byte of data is shifted out on DQ0 and DQ1. The whole memory can be read with a single DOFR instruction. When the highest address is reached, the address counter rolls over to 00 0000h so that the read sequence can be continued indefinitely.

Figure 13: DUAL OUTPUT FAST READ Instruction Sequence

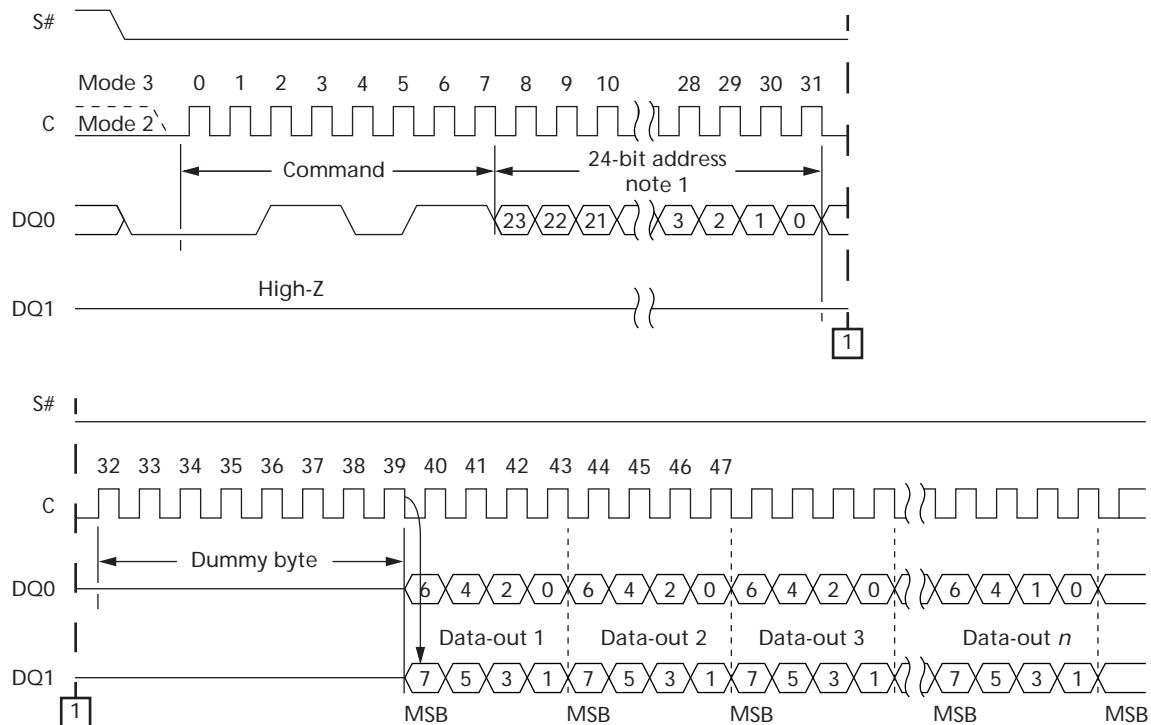

QUAD OUTPUT FAST READ (QOFR)

The QUAD OUTPUT FAST READ (QOFR) instruction is very similar to the FAST_READ instruction, except that the data are shifted out on four pins (pins DQ0, DQ1, DQ2, and DQ3) instead of just one. Outputting the data on four pins instead of one quadruples the data transfer bandwidth compared to using the FAST_READ instruction.

The device is first selected by driving S# LOW. The instruction code for the QOFR instruction is followed by a 3-byte address A[23:0] and a dummy byte, with each bit being latched in during the rising edge of C. Then the memory contents at that address are shifted out on DQ0, DQ1, DQ2, and DQ3 at a maximum frequency f_C , during the falling edge of C. The instruction sequence is shown in Figure 14 on page 27.

The first byte addressed can be at any location. The address is automatically incremented to the next higher address after each byte of data is shifted out on DQ0, DQ1, DQ2, and DQ3. The whole memory can be read with a single QOFR instruction. When the highest address is reached, the address counter rolls over to 00 0000h so that the read sequence can be continued indefinitely.

Figure 14: QUAD OUTPUT FAST READ Instruction Sequence

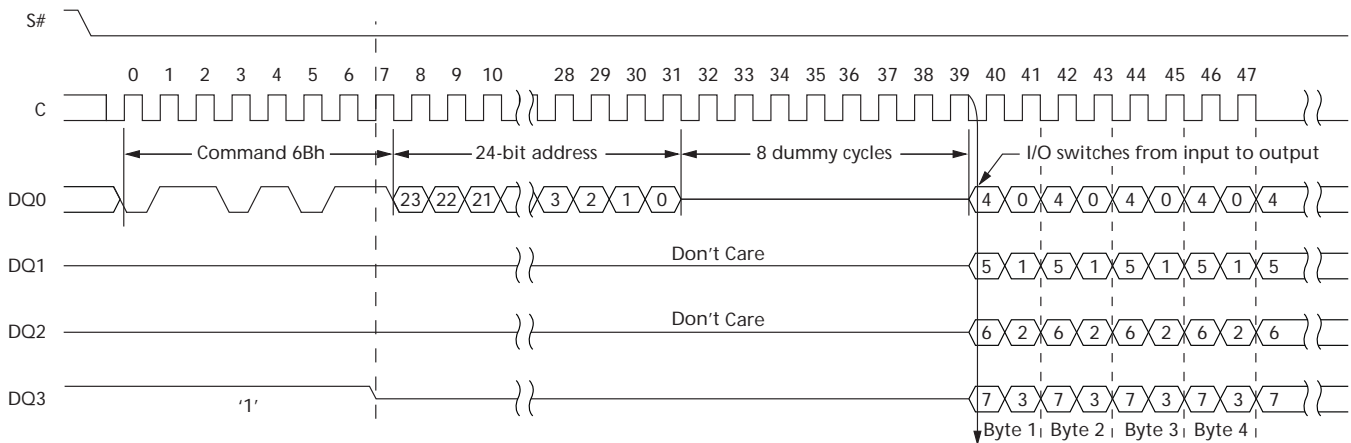

- Notes:
1. After 40 clock cycles (cycle labeled 39 in the figure), data inputs (DQ1) must be released because they become outputs.
 2. After command 6Bh is recognized, W# and HOLD# functionality is automatically disabled.

PAGE PROGRAM (PP)

Note: The following description of PAGE PROGRAM (PP) applies to all instances of PAGE PROGRAM, including legacy PROGRAM, bit-alterable WRITE, and PROGRAM on all 1s.

The PP instruction enables bytes to be programmed/written in the memory. Before it can be accepted, a WREN instruction must previously have been executed. After the WREN instruction has been decoded, the device sets the WEL bit.

The PP instruction is entered by driving S# LOW, followed by the instruction code, three address bytes, and at least one data byte on serial data input (DQ0). If the six least significant address bits A[5:0] are not all zero, all transmitted data that goes beyond the end of the current page are programmed from the start address of the same page (from the address whose six least significant bits A[5:0] are all zero). S# must be driven LOW for the entire duration of the sequence. The instruction sequence is shown in Figure 15 on page 28.

If more than 64 bytes are sent to the device, previously latched data are discarded, and the last 64 data bytes are guaranteed to be programmed/written correctly within the same page. If fewer than 64 data bytes are sent to the device, they are correctly programmed/written at the requested addresses without having any effects on the other bytes of the same page. (With PROGRAM on all 1s, the entire page should already have been set to all 1s [FFh].)

For optimized timings, it is recommended to use the PP instruction to program all consecutive targeted bytes in a single sequence instead of using several PP sequences with each containing only a few bytes (see Table 16 on page 37).

S# must be driven HIGH after the eighth bit of the last data byte has been latched in; otherwise the PP instruction is not executed.

As soon as S# is driven HIGH, the self-timed PAGE PROGRAM cycle (whose duration is t_{PP}) is initiated. While the PAGE PROGRAM cycle is in progress, the status register may be read to check the value of the WIP bit. The WIP bit is 1 during the self-timed PAGE

PROGRAM cycle and is 0 when it is completed. At some unspecified time before the cycle is completed, the write enable latch (WEL) bit is reset. RDSR is the only instruction accepted while a PAGE PROGRAM operation is in progress; all other instructions are ignored.

A PP instruction applied to a page that is protected by the block protect bits (BP3, BP2, BP1, BP0) is not executed (see Table 2 on page 14 and Table 3 on page 15).

Figure 15: PP Instruction Sequence

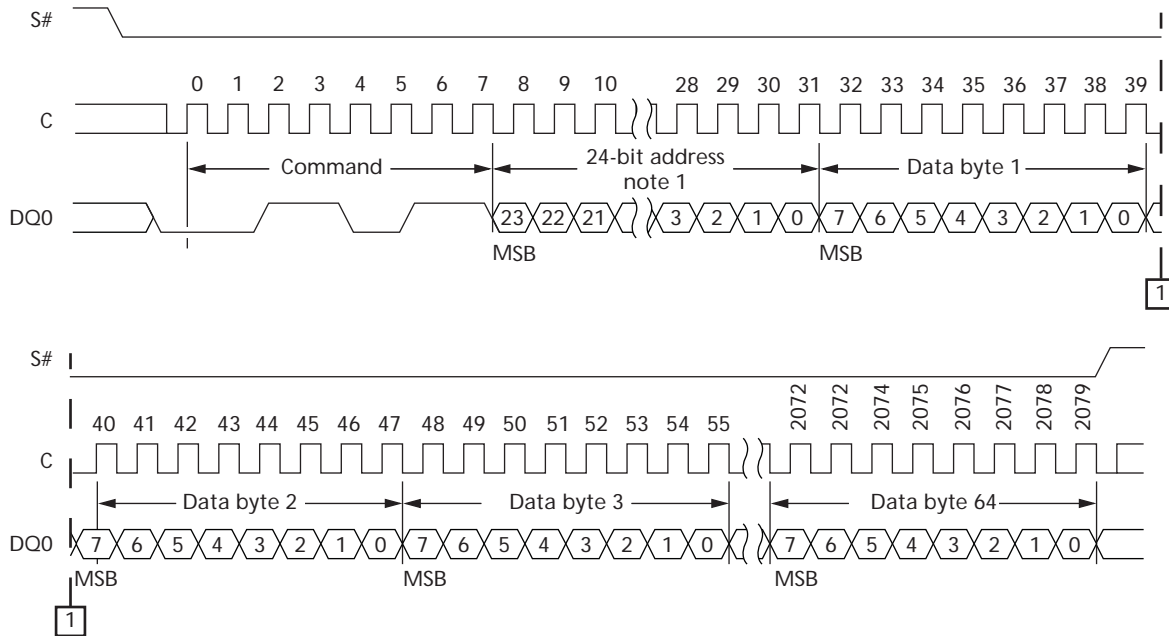

DUAL INPUT FAST PROGRAM (DIFP)

Note: The following description of DUAL INPUT FAST PROGRAM (DIFP) applies to all instances of DUAL INPUT FAST PROGRAM, including legacy PROGRAM, bit-alterable WRITE, and PROGRAM on all 1s.

The DUAL INPUT FAST PROGRAM (DIFP) instruction is very similar to the PP instruction, except that the data are entered on two pins (pins DQ0 and DQ1) instead of just one. Inputting the data on two pins instead of one pin doubles the data transfer bandwidth compared with using the PP instruction.

The DIFP instruction is entered by driving chip select (S#) LOW, followed by the instruction code, three address bytes, and at least one data byte on serial data input (DQ0).

If the six least significant address bits (A[5:0]) are not all zero, all transmitted data that goes beyond the end of the current page are programmed from the start address of the same page (from the address whose six least significant bits (A[5:0]) are all zero). Chip select (S#) must be driven LOW for the entire duration of the sequence. The instruction sequence is shown in Figure 16 on page 29.

If more than 64 bytes are sent to the device, previously latched data are discarded and the last 64 data bytes are guaranteed to be programmed/written correctly within the same page. If fewer than 64 data bytes are sent to device, they are correctly

programmed/written at the requested addresses without having any effects on the other bytes in the same page. (With PROGRAM on all 1s, the entire page should already have been set to all 1s [FFh].)

For optimized timings, it is recommended to use the DIFP instruction to program all consecutive targeted bytes in a single sequence rather than using several DIFP sequences, each containing only a few bytes (see Table 16 on page 37).

S# must be driven HIGH after the eighth bit of the last data byte has been latched in; otherwise the DIFP instruction is not executed.

As soon as S# is driven HIGH, the self-timed PAGE PROGRAM cycle (whose duration is t_{PP}) is initiated. While the DIFP cycle is in progress, the status register may be read to check the value of the WIP bit. The WIP bit is 1 during the self-timed PAGE PROGRAM cycle and 0 when it is completed. At some unspecified time before the cycle is completed, the WEL bit is reset. RDSR is the only instruction accepted while a DUAL INPUT FAST PROGRAM operation is in progress; all other instructions are ignored.

A DIFP instruction applied to a page that is protected by the block protect bits is not executed (see Table 2 on page 14).

Figure 16: DIFP Instruction Sequence

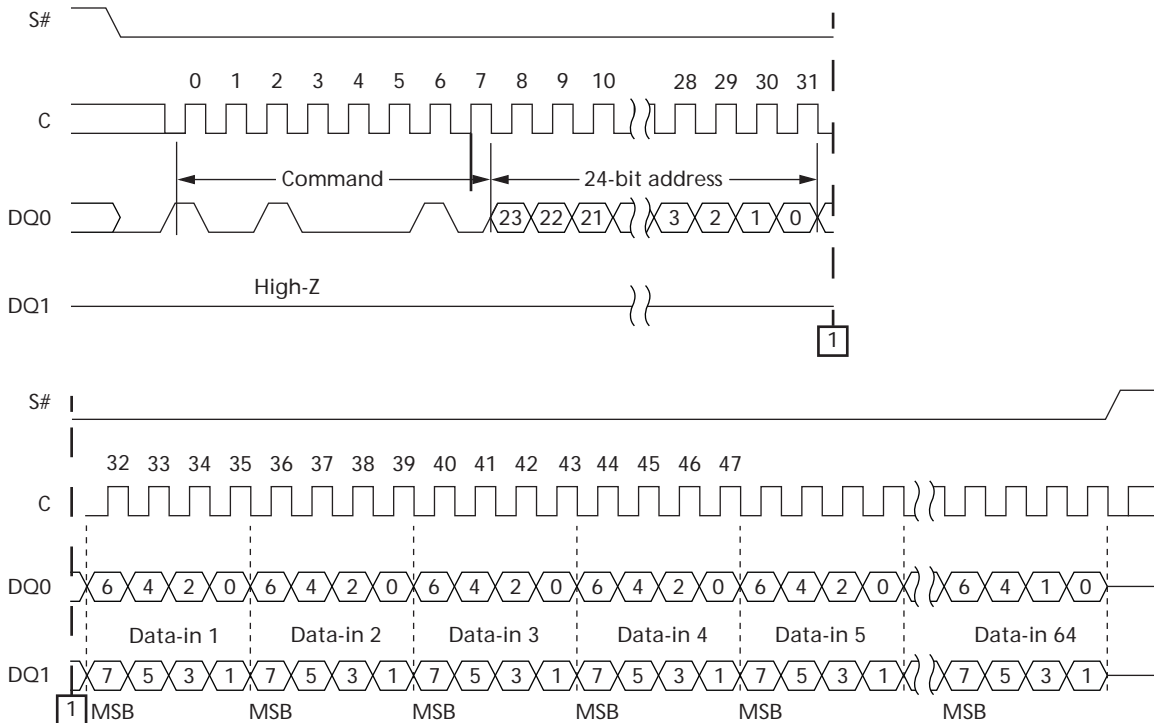

QUAD INPUT FAST PROGRAM (QIFP)

Note: The following description of QUAD INPUT FAST PROGRAM applies to all instances of QUAD INPUT FAST PROGRAM, including legacy PROGRAM, bit-alterable WRITE, and PROGRAM on all 1s.

The QUAD INPUT FAST PROGRAM (QIFP) instruction is very similar to the PP instruction, except that the data are entered on four pins (DQ0, DQ1, DQ2, and DQ3) instead of one. Inputting the data on four pins instead of one quadruples the data transfer bandwidth compared with using the PP instruction.

The QIFP instruction is entered by driving S# LOW, followed by the instruction code, three address bytes, and at least one data byte on DQ0.

If the six least significant address bits A[5:0] are not all zero, all transmitted data that goes beyond the end of the current page are programmed from the start address of the same page (from the address whose six least significant bits A[5:0] are all zero). S# must be driven LOW for the entire duration of the sequence. The instruction sequence is shown in Figure 17 on page 30.

If more than 64 bytes are sent to the device, previously latched data are discarded and the last 64 data bytes are guaranteed to be programmed correctly within the same page. If fewer than 64 data bytes are sent to device, they are correctly programmed at the requested addresses without having any effects on the other bytes in the same page. (With PROGRAM on all 1s, the entire page should already have been set to all 1s [FFh].)

For optimized timings, it is recommended to use the QIFP instruction to program all consecutive targeted bytes in a single sequence rather than using several QIFP sequences each containing only a few bytes (see Table 16 on page 37).

S# must be driven HIGH after the eighth bit of the last data byte has been latched in; otherwise the QIFP instruction is not executed. As soon as S# is driven HIGH, the self-timed PAGE PROGRAM cycle (whose duration is t_{PP}) is initiated. While the DIFP cycle is in progress, the status register may be read to check the value of the WIP bit. The WIP bit is 1 during the self-timed PAGE PROGRAM cycle and 0 when it is completed. At some unspecified time before the cycle is completed, the WEL bit is reset. RDSR is the only instruction accepted while a QUAD INPUT FAST PROGRAM operation is in progress; all other instructions are ignored.

A QIFP instruction applied to a page that is protected by the block protect bits is not executed (see Table 2 on page 14).

Figure 17: QIFP Instruction Sequence

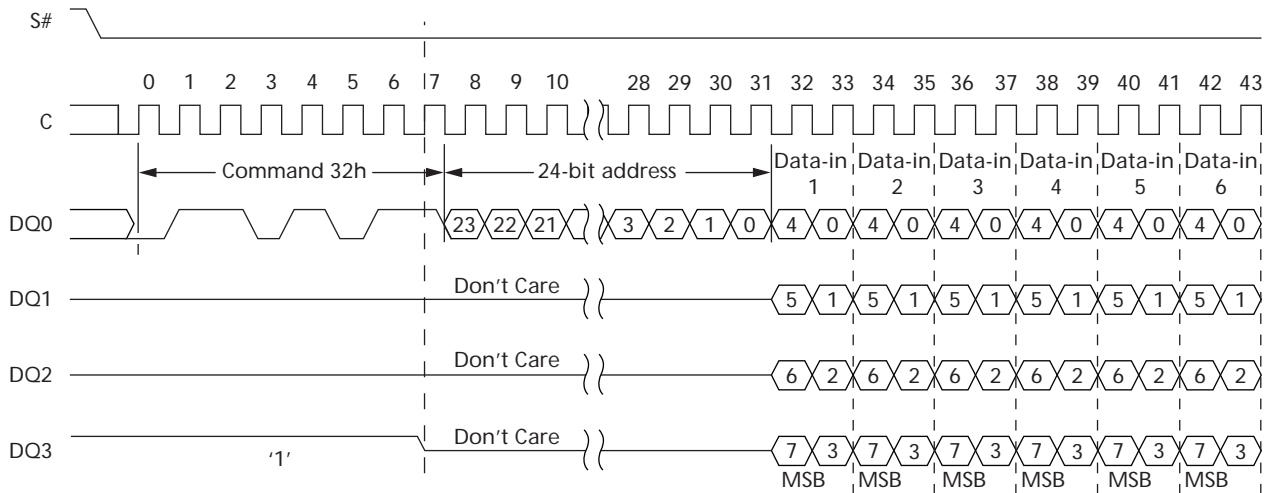

Notes: 1. After 32h is recognized, W# and HOLD# functionality is automatically disabled.

SECTOR ERASE (SE)

The SECTOR ERASE (SE) instruction sets all bits that are inside the chosen sector to 1 (FFh). Before it can be accepted, a WREN instruction must previously have been executed. After the WREN instruction has been decoded, the device sets the WEL bit.

The SE instruction is entered by driving S# LOW, followed by the instruction code and three address bytes on DQ0. Any address inside the sector is a valid address for the SE instruction (see Table 3 on page 15). S# must be driven LOW for the entire duration of the sequence. The instruction sequence is shown in Figure 18 on page 31.

S# must be driven HIGH after the eighth bit of the last address byte has been latched in; otherwise the SE instruction is not executed. As soon as S# is driven HIGH, the self-timed SECTOR ERASE cycle (whose duration is t_{SE}) is initiated. While the SECTOR ERASE cycle is in progress, the status register may be read to check the value of the WIP bit. The WIP bit is 1 during the self-timed SECTOR ERASE cycle and is 0 when it is completed. At some unspecified time before the cycle is completed, the WEL bit is reset. RDSR is the only instruction accepted while device is busy with ERASE operation; all other instructions are ignored.

An SE instruction applied to a page that is protected by the block protect bits is not executed (see Table 2 on page 14 and Table 3 on page 15).

Figure 18: SE Instruction Sequence

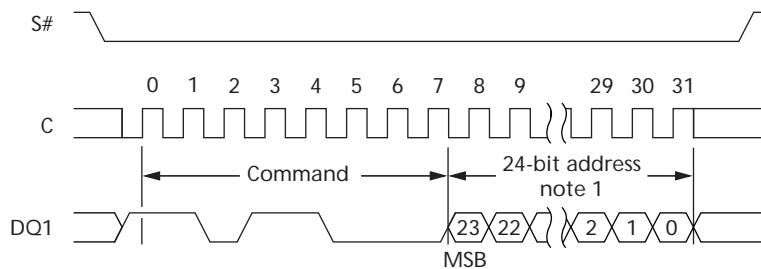

BULK ERASE (BE)

The BULK ERASE (BE) instruction sets all bits to 1 (FFh). Before it can be accepted, a WREN instruction must previously have been executed. After the WREN instruction has been decoded, the device sets the WEL bit.

The BE instruction is entered by driving S# LOW, followed by the instruction code on DQ0. S# must be driven LOW for the entire duration of the sequence. The instruction sequence is shown in Figure 19 on page 32.

S# must be driven HIGH after the eighth bit of the instruction code has been latched in; otherwise the BE instruction is not executed. As soon as S# is driven HIGH, the self-timed BULK ERASE cycle (whose duration is t_{BE}) is initiated. While the BULK ERASE cycle is in progress, the status register may be read to check the value of the WIP bit. The WIP bit is 1 during the self-timed BULK ERASE cycle and is 0 when it is completed. At some unspecified time before the cycle is completed, the WEL bit is reset. RDSR is the only instruction accepted while the device is busy with the ERASE operation; all other instructions are ignored.

The BE instruction is executed only if all block protect bits are 0. The BE instruction is ignored if one or more sectors are protected.

Figure 19: BE Instruction Sequence

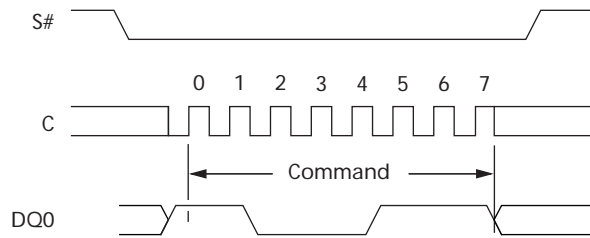

Power-Up and Power-Down

At power-up and power-down, the device must not be selected (that is S#) must follow the voltage applied on V_{CC} until V_{CC} reaches the correct value:

- $V_{CC,min}$ at power-up, and then for a further delay of t_{VSL}
- V_{SS} at power-down

A safe configuration is provided in “SPI Modes” on page 9.

To avoid data corruption and inadvertent WRITE operations during power-up, a power on reset (POR) circuit is included. The logic inside the device is held reset while V_{CC} is less than the power on reset (POR) threshold voltage, V_{WI} . All operations are disabled, and the device does not respond to any instruction.

The device ignores all WREN, PP, DIFP, SE, BE, and WRSR instructions until a time delay of t_{PUW} has elapsed after the moment that V_{CC} rises above the V_{WI} threshold. However, the correct operation of the device is not guaranteed if, by this time, V_{CC} is still below $V_{CC,min}$. No WRITE STATUS REGISTER, PROGRAM, or ERASE instructions should be sent until the later of:

- t_{PUW} after V_{CC} has passed the V_{WI} threshold
- t_{VSL} after V_{CC} has passed the $V_{CC,min}$ level

These values are specified in Table 9 on page 33.

If the time, t_{VSL} , has elapsed after V_{CC} rises above $V_{CC,min}$, the device can be selected for READ instructions even if the t_{PUW} delay has not yet fully elapsed.

After power-up, the device is in the following states:

- The device is in the standby power mode.
- The WEL bit is reset.
- The WIP bit is reset.

Normal precautions must be taken for supply line decoupling to stabilize the V_{CC} supply. Each device in a system should have the V_{CC} line decoupled by a suitable capacitor close to the package pins (generally, this capacitor is about 100nF).

At power-down when V_{CC} drops from the operating voltage to below the power on reset (POR) threshold voltage, V_{WI} , all operations are disabled and the device does not respond to any instruction (if power-down occurs while a WRITE, PROGRAM, or ERASE cycle is in progress, some data corruption may occur).

Figure 20: Power-Up Timing

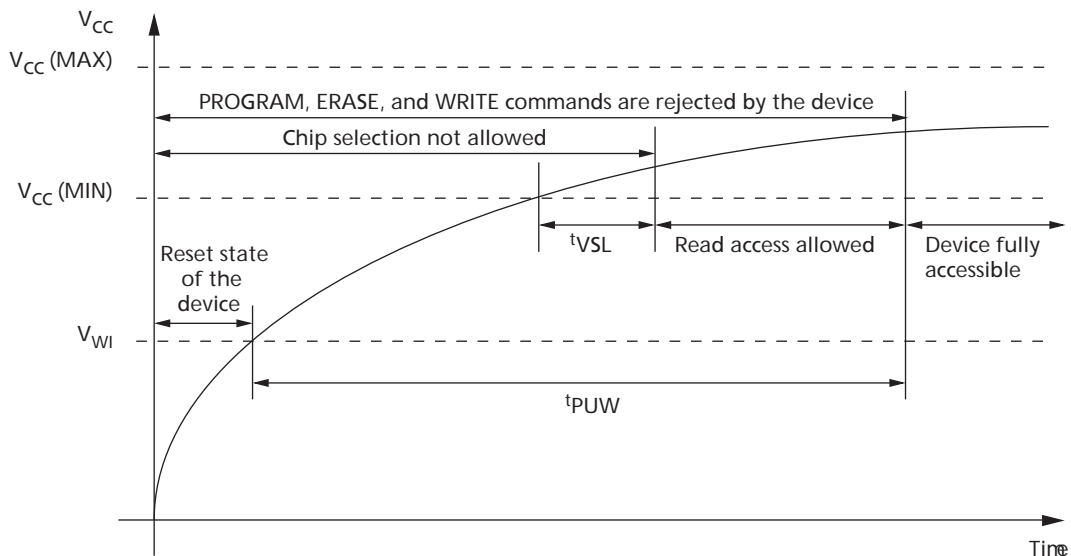

Table 9: Power-Up Timing and V_{WI} Threshold

Symbol	Parameter	Min	Max	Unit
t_{VSL}^1	$V_{CC, \text{min}}$ to S# LOW	100	–	μs
t_{PUW}^1	Time delay to write instruction	1	10	ms
V_{WI}^1	Write inhibit voltage	1.5	2.5	V

Notes: 1. These parameters are characterized only.

Initial Delivery State

The device is delivered with the memory array erased: all bits are set to 1 (each byte contains FFh). The status register contains 00h (all status register bits are 0).

Maximum Ratings

Stresses greater than those listed in Table 10 may cause permanent damage to the device. This is a stress rating only, and functional operation of the device at these or any other conditions outside those indicated in the operational sections of this specification is not implied. Exposure to absolute maximum rating conditions for extended periods may adversely affect reliability.

Table 10: Absolute Maximum Ratings

Note 1 applies to the entire table

Symbol	Parameter	Min	Max	Unit
V_{IO}	Input and output voltage (with respect to ground)	-0.6	$V_{CC} + 0.6$	V
V_{CC}	Supply voltage	-0.6	4.0	V
V_{ESD}	Electrostatic discharge voltage (human body model) ¹	-2000	2000	V

Notes: 1. JEDEC Standard JESD22-A114A (C1 = 100pF; R1 = 1500Ω; R2 = 500Ω).

DC and AC Characteristics

The parameters in the DC and AC characteristics are derived from tests performed under the measurement conditions summarized in the relevant tables. Operating conditions in device circuits must match the measurement conditions when relying on the quoted parameters.

Operating Conditions

Table 11: Operating Conditions

Symbol	Parameter	Min	Typ	Max	Unit
V_{CC}	Supply voltage	2.7	-	3.6	V
T_A	Ambient operating temperature (66 MHz)	0	-	70	°C
T_A	Ambient operating temperature (33 MHz)	-30	-	85	°C

Notes: 1. Data retention for Micron PCM is 10 years at 70°C. For additional documentation about data retention, contact your local Micron sales representative.

Endurance Specifications

Table 12: Endurance Specifications

Parameter	Condition	Min	Units	Notes
WRITE cycle	Main block	1,000,000	Cycles per 32-byte page	1
	Parameter block	1,000,000		

Notes: 1. A WRITE cycle is defined as any time a bit changes within a 32-byte page.

AC Measurement Conditions

Table 13: AC Measurement Conditions

Symbol	Parameter	Min	Max	Unit
C_L	Load capacitance	30	30	pF
	Input rise and fall times	-	5	ns
	Input pulse voltages	0.2–0.8 V_{CC}		V
	Input timing reference voltages	0.3–0.7 V_{CC}		V
	Output timing reference voltages	$V_{CC}/2$		V

Figure 21: AC Measurement I/O Waveform

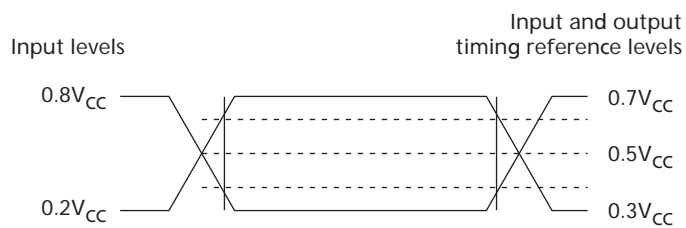

Capacitance

Table 14: Capacitance¹

Symbol	Parameter	Test Condition	Min	Max	Unit
$C_{IN/OUT}$	Input/output capacitance (DQ0/DQ1)	$V_{OUT} = 0V$	-	8	pF
C_{IN}	Input capacitance (other pins)	$V_{IN} = 0V$	-	6	pF

Notes: 1. Sampled only, not 100% tested, at $T_A = 25^\circ C$ and a frequency of 33 MHz.

DC Characteristics

Table 15: DC Characteristics

Symbol	Parameter	Test Condition ¹	Min	Max	Unit
I_{LI}	Input leakage current		-	± 2	μA
I_{LO}	Output leakage current		-	± 2	μA
I_{CC1}	Standby current	$S\# = V_{CC}, V_{IN} = V_{SS}$ or V_{CC}	-	200	μA
I_{CC3}	Operating current (READ)	$C = 0.1V_{CC} / 0.9V_{CC}$ at 66 MHz, DQ1 = open	-	16	mA
		$C = 0.1V_{CC} / 0.9V_{CC}$ at 33 MHz, DQ1 = open	-	7	mA
	Operating current (DOFR)	$C = 0.1V_{CC} / 0.9V_{CC}$ at 66 MHz, DQ0 = DQ1 = open	-	20	mA
	Operating current (QOFR)	$C = 0.1V_{CC} / 0.9V_{CC}$ at 50 MHz, DQ0 = DQ1 = DQ2 = DQ3 = open	-	24	mA
I_{CC4}	Operating current (PP)	$S\# = V_{CC}$	-	50	mA
	Operating current (DIFP)	$S\# = V_{CC}$	-	50	mA
	Operating current (QIFP)	$S\# = V_{CC}$	-	50	mA
I_{CC5}	Operating current (WRSR)	$S\# = V_{CC}$	-	50	mA
I_{CC6}	Operating current (SE, BE)	$S\# = V_{CC}$	-	50	mA
V_{IL}	Input low voltage		- 0.5	$0.3 V_{CC}$	V
V_{IH}	Input high voltage		$0.7 V_{CC}$	$V_{CC} + 0.4$	V
V_{OL}	Output low voltage	$I_{OL} = 1.6mA$	-	0.4	V
V_{OH}	Output high voltage	$I_{OH} = -100\mu A$	$V_{CC} - 0.2$		V

Notes: 1. For additional test conditions, refer to Table 11 on page 34.

AC Characteristics

Table 16: AC Characteristics

AC characteristics are based on preliminary data

Test Conditions ¹						
Symbol	Alt	Parameter	Min	Typ ²	Max	Unit
f_C	f_C	Clock frequency for the following instructions: DOFR, DIFP, FAST_READ, SE, BE, WREN, WRDI, RDID, RDSR, WRSR (0°C to 70°C)	DC	–	66	MHz
		Clock frequency for the following instructions: QOFR, QIFP (0°C to 70°C)	DC	–	50	MHz
f_R		Clock frequency for READ instructions (0°C to 70°C)	DC	–	33	MHz
f_C / f_R		Clock frequency for all instructions: QOFR, QIFR, DOFR, DIFP, FAST_READ, READ SE, BE, WREN, WRDI, RDID, RDSR, WRSR (–30°C to 85°C)	DC	–	33	MHz
t_{CH}^3	t_{CLH}	Clock HIGH time	6.5	–	–	ns
t_{CL}^2	t_{CLL}	Clock LOW time	6.5	–	–	ns
t_{CLCH}^4		Clock rise time ⁵ (peak to peak)	0.1	–	–	V/ns
t_{CHCL}^4		Clock fall time ⁵ (peak to peak)	0.1	–	–	V/ns
t_{SLCH}	t_{CSS}	S# active setup time (relative to C)	5	–	–	ns
t_{CHSL}		S# not active hold time (relative to C)	5	–	–	ns
t_{DVCH}	t_{DSU}	Data-in setup time	2	–	–	ns
t_{CHDX}	t_{DH}	Data-in hold time	5	–	–	ns
t_{CHSH}		S# active hold time (relative to C)	5	–	–	ns
t_{SHCH}		S# not active setup time (relative to C)	5	–	–	ns
t_{SHSL}	t_{CSH}	S# deselect time	80	–	–	ns
t_{SHOZ}^4	t_{DIS}	Output disable time	–	–	8	ns
t_{CLOV}	t_V	Clock LOW to output valid under 30pF	–	–	9	ns
		Clock LOW to output valid under 10pF	–	–	8	ns
t_{CLOX}	t_{HO}	Output hold time	0	–	–	ns
t_{HLCH}		HOLD# setup time (relative to C)	5	–	–	ns
t_{CHHH}		HOLD# hold time (relative to C)	5	–	–	ns
t_{HHCH}		HOLD# setup time (relative to C)	5	–	–	ns
t_{CHHL}		HOLD# hold time (relative to C)	5	–	–	ns
t_{HHQX}^4	t_{LZ}	HOLD# to output Low-Z	–	–	10	ns
t_{HLOZ}^4	t_{HZ}	HOLD# to output High-Z	–	–	10	ns
t_{WHSL}^6		Write protect setup time	20	–	–	ns
t_{SHWL}^6		Write protect hold time	100	–	–	ns
t_{RDP}^4		S# High to standby mode	–	–	30	μs
t_W		WRITE STATUS REGISTER cycle time	–	200	350	μs
t_{PP}^7		PAGE PROGRAM cycle time (64 bytes) (legacy PROGRAM and bit-alterable WRITE)	–	120	360	μs
		PAGE PROGRAM cycle time (64 bytes) (Program on all 1s)	–	71	280	
t_{SE}		SECTOR ERASE cycle time	–	400	800	ms
t_{BE}		BULK ERASE cycle time	–	50	100	s

- Notes: 1. For additional test conditions, refer to Table 11 on page 34 and Table 13 on page 35.
 2. Typical values given for $T_A = 25^\circ\text{C}$ at nominal V_{CC} .

3. $t_{CH} + t_{CL}$ must be $\geq 1/f_C$.
4. Value guaranteed by characterization, not 100% tested in production.
5. Expressed as a slew rate.
6. Only applicable as a constraint for a WRSR instruction when SRWD is set to 1.
7. When using the PP instruction to program consecutive bytes, optimized timings are obtained with one sequence, including all the bytes versus several sequences of only a few bytes ($1 \leq n \leq 64$).

Figure 22: Serial Input Timing

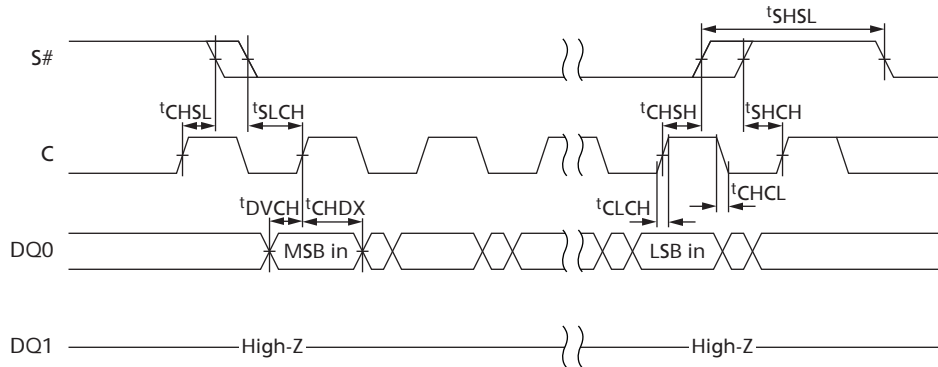

Figure 23: Write Protect Setup and Hold Timing During WRSR when SRWD = 1

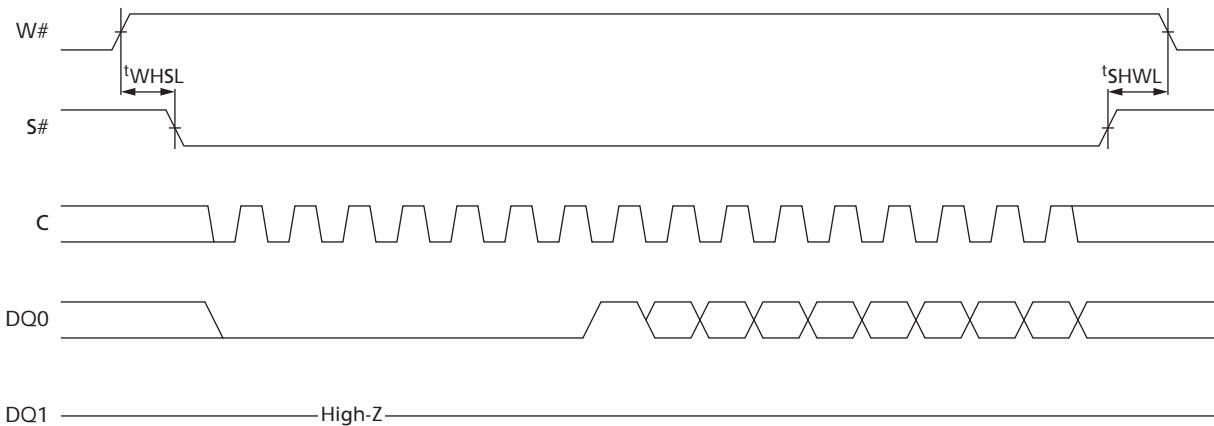

Figure 24: Hold Timing

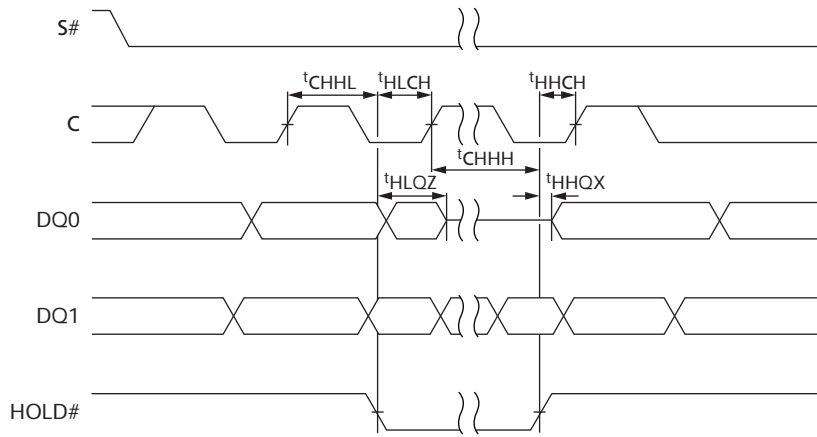
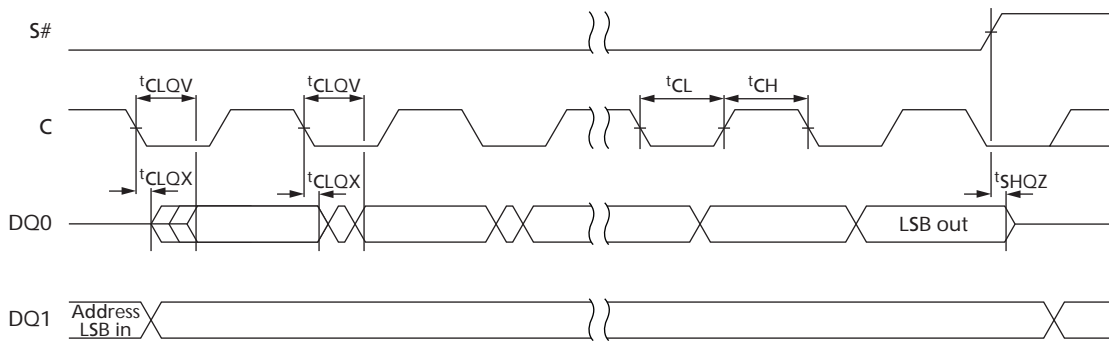

Figure 25: Output Timing



Package Dimensions

P5Q serial PCM packages are RoHS compliant with a lead-free, second-level interconnect, which is marked on the package and on the inner box label in compliance with JEDEC Standard JESD97. The maximum ratings related to soldering conditions are also marked on the inner box label.

Figure 26: SO16 Wide - 16-Lead Plastic Small-Outline, 300 Mils Body Width, Package Outline

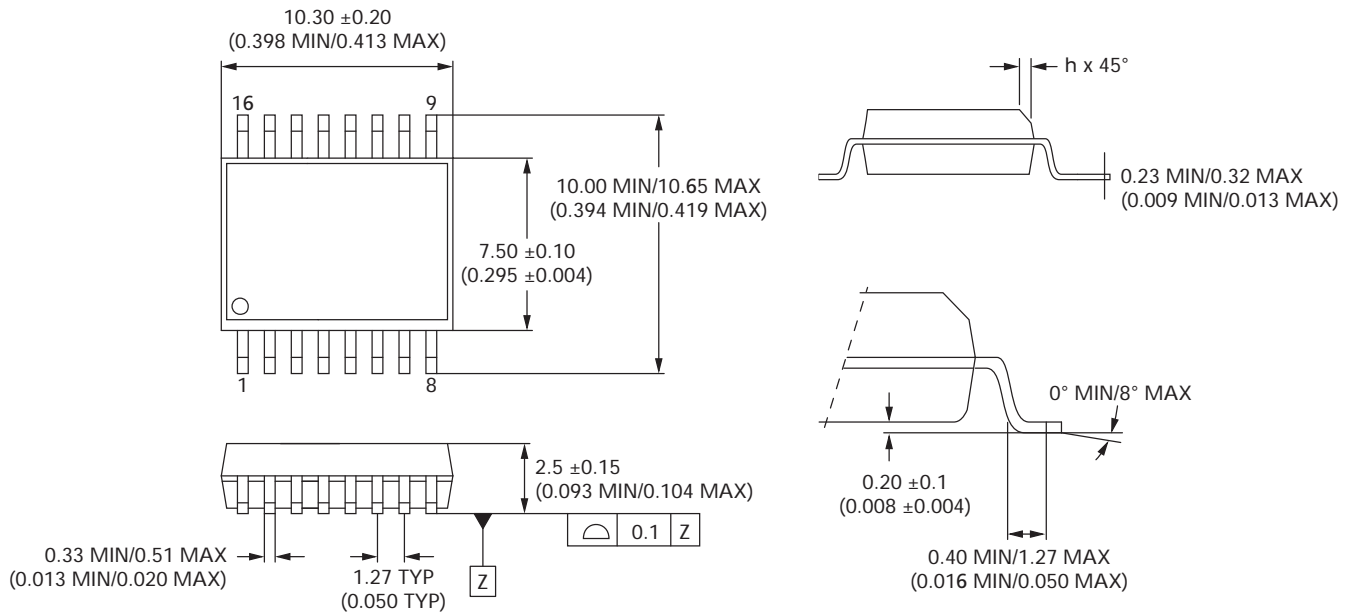

Table 17: SO16 wide - Wide - 16-Lead Plastic Small-Outline, 300 Mils Body Width, Mechanical Data

Symbol	Millimeters			Inches		
	Typ	Min	Max	Typ	Min	Max
A	-	2.35	2.65	-	0.093	0.104
A1	-	0.10	0.30	-	0.004	0.012
B	-	0.33	0.51	-	0.013	0.020
C	-	0.23	0.32	-	0.009	0.013
D	-	10.10	10.50	-	0.398	0.413
E	-	7.40	7.60	-	0.291	0.299
e	1.27	-	-	0.050	-	-
H	-	10.00	10.65	-	0.394	0.419
h	-	0.25	0.75	-	0.010	0.030
L	-	0.40	1.27	-	0.016	0.050
q	-	0°	8°	-	0°	8°
ddd	-	-	0.10	-	-	0.004



Ordering Information

Table 18: Active Line Item Ordering Table

Part Number	Description
NP5Q128A13ESFC0E	3V, SOIC, Pb-free, 10.34 x 10.34 x 2.54, 16-lead (0°C to 70°C)
NP5Q128AE3ESFC0E	3V, SOIC, Pb-free, 10.34 x 10.34 x 2.54, 16-lead (-30°C to 85 °C)

Notes: 1. For SO8 packaging solutions, contact your Micron representative for details.

8000 S. Federal Way, P.O. Box 6, Boise, ID 83707-0006, Tel: 208-368-3900
www.micron.com/productsupport Customer Comment Line: 800-932-4992

Micron and the Micron logo are trademarks of Micron Technology, Inc. All other trademarks are the property of their respective owners. This data sheet contains minimum and maximum limits specified over the power supply and temperature range set forth herein. Although considered final, these specifications are subject to change, as further product development and data characterization sometimes occur.

Looking for pricing, stock, or lifecycle information?

Click below to explore more details on WIN SOURCE:

- ⊖ [View NP5Q128A13ESFC0E on WIN SOURCE](#)
- ⊖ [Micron Technology Inc. Information](#)

Optimize Your Supply Chain with WIN SOURCE Solutions

- ✓ Global Sourcing Solution
- ✓ Obsolete Management
- ✓ Cost Control Management
- ✓ Shortage Management
- ✓ Alternative Solution
- ✓ Excess Inventory Management