



**THE DATASHEET OF
NP2600SAMCT3G**



NPMC Series

Ultra Low Capacitance TSPD

The NPMC series of Low Capacitance Thyristor Surge Protection Devices (TSPD) protect sensitive electronic equipment from transient overvoltage conditions. Due to their ultra low off-state capacitance (C_o), they offer minimal signal distortion for high speed equipment such as DSL and T1/E1 circuits. The low nominal offstate capacitance translates into the extremely low differential capacitance offering superb linearity with applied voltage or frequency.

The NPMC Series helps designers to comply with the various regulatory standards and recommendations including: GR-1089-CORE, IEC 61000-4-5, ITU K.20/K.21/K.45, IEC 60950, TIA-968-A, FCC Part 68, EN 60950, UL 1950.

Features

- Ultra Low – Micro Capacitance
- Low Leakage (Transparent)
- High Surge Current Capabilities
- Precise Turn on Voltages
- Low Voltage Overshoot
- These are Pb-Free Devices

Typical Applications

- xDSL Central Office and Customer Premise
- T1/E1
- Other Broadband High Speed Data Transmission Equipment

ELECTRICAL PARAMETERS

Device	V_{DRM}	$V_{(BO)}$	V_T	I_{DRM}	$I_{(BO)}$	I_T	I_H
	V	V	V	μA	mA	A	mA
NP0640SxMCT3G	58	77	4	5	800	2.2	150
NP0720SxMCT3G	65	88	4	5	800	2.2	150
NP0900SxMCT3G	75	98	4	5	800	2.2	150
NP1100SxMCT3G	90	130	4	5	800	2.2	150
NP1300SxMCT3G	120	160	4	5	800	2.2	150
NP1500SxMCT3G	140	180	4	5	800	2.2	150
NP1800SxMCT3G	170	220	4	5	800	2.2	150
NP2100SxMCT3G	180	240	4	5	800	2.2	150
NP2300SxMCT3G	190	260	4	5	800	2.2	150
NP2600SxMCT3G	220	300	4	5	800	2.2	150
NP3100SxMCT3G	275	350	4	5	800	2.2	150
NP3500SxMCT3G	320	400	4	5	800	2.2	150

G = indicates leadfree, RoHS compliant

* Recognized Components



ON Semiconductor®

<http://onsemi.com>

ULTRA LOW CAPACITANCE BIDIRECTIONAL SURFACE MOUNT THYRISTOR 64 – 350 VOLTS



SMB
JEDEC DO-214AA
CASE 403C

MARKING DIAGRAM



- A = Assembly Location
 - Y = Year
 - WW = Work Week
 - xxxx = Specific Device Code (NPxxx0SxMC)
 - = Pb-Free Package
- (Note: Microdot may be in either location)

ORDERING INFORMATION

Device	Package	Shipping [†]
NPxxx0SxMCT3G	SMB (Pb-Free)	2500 Tape & Reel

[†]For information on tape and reel specifications, including part orientation and tape sizes, please refer to our Tape and Reel Packaging Specifications Brochure, BRD8011/D.

NPMC Series

TEL-COM STANDARDS

Specification	Waveform		x = series ratings			Unit
	Voltage (μ s)	Current (μ s)	A	B	C	
GR-1089-CORE	2x10	2x10	150	250	500	A(pk)
TIA-968-A	10x160	10x160	90	150	200	
GR-1089-CORE	10x360	10x360	75	125	175	
TIA-968-A	10x560	10x560	50	100	150	
ITU-T K.20/21	10x700	5x310	75	100	200	
GR-1089-CORE	10x1000	10x1000	50	80	100	

SURGE RATINGS

Characteristics	Symbol	A	B	C	Unit
Nominal Pulse Surge Short Circuit Current Non – Repetitive Double Exponential Decay Waveform (Notes 1, 2 and 3)					A(pk)
2 x 10 μ Sec	I _{PPS1}	150	250	500	
8 x 20 μ Sec	I _{PPS2}	150	250	400	
10 x 160 μ Sec	I _{PPS3}	90	150	200	
10 x 360 μ Sec	I _{PPS4}	75	125	150	
10 x 560 μ Sec	I _{PPS5}	50	100	150	
10 x 700 μ Sec	I _{PPS6}	75	100	200	
10 x 1000 μ Sec	I _{PPS7}	50	80	100	

1. Allow cooling before testing second polarity.
2. Measured under pulse conditions to reduce heating.
3. Nominal values may not represent the maximum capability of a device.

CAPACITANCE

Characteristics	Symbol	Max			Unit
		A	B	C	
(f=1.0 MHz, 1.0 V _{rms} , 2 Vdc bias) (C _o Apx 45% @ 50 V)	C _o				pF
NP0640SxMCT3G		23	29	33	
NP0720SxMCT3G		23	29	33	
NP0900SxMCT3G		23	29	33	
NP1100SxMCT3G		23	29	33	
NP1300SxMCT3G		23	29	33	
NP1500SxMCT3G		23	29	33	
NP1800SxMCT3G		23	29	33	
NP2100SxMCT3G		23	29	33	
NP2300SxMCT3G		23	29	33	
NP2600SxMCT3G		23	29	33	
NP3100SxMCT3G		23	29	33	
NP3500SxMCT3G		23	29	33	

MAXIMUM RATINGS (T_A = 25°C unless otherwise noted)

Symbol	Rating	Value	Unit	
V _{DRM}	Repetitive peak off-state voltage: Rated maximum (peak) continuous voltage that may be applied in the off-state conditions including all dc and repetitive alternating voltage components. (Stresses exceeding Maximum Ratings may damage the device. Maximum Ratings are stress ratings only. Functional operation above the Recommended Operating Conditions is not implied. Extended exposure to stresses above the Recommended Operating Conditions may affect device reliability.)	NP0640SxMCT3G	±58	V
		NP0720SxMCT3G	±65	
		NP0900SxMCT3G	±75	
		NP1100SxMCT3G	±90	
		NP1300SxMCT3G	±120	
		NP1500SxMCT3G	±140	
		NP1800SxMCT3G	±170	
		NP2100SxMCT3G	±180	
		NP2300SxMCT3G	±190	
		NP2600SxMCT3G	±220	
		NP3100SxMCT3G	±275	
		NP3500SxMCT3G	±320	

NPMC Series

ELECTRICAL CHARACTERISTICS TABLE ($T_A = 25^\circ\text{C}$ unless otherwise noted)

Symbol	Rating	Min	Typ	Max	Unit	
$V_{(BO)}$	Breakover voltage: The maximum voltage across the device in or at the breakdown region. (Note 4) VDC = 1000 V, dv/dt = 100 V/ μs	NP0640SxMCT3G			± 77	V
		NP0720SxMCT3G			± 88	
		NP0900SxMCT3G			± 98	
		NP1100SxMCT3G			± 130	
		NP1300SxMCT3G			± 160	
		NP1500SxMCT3G			± 180	
		NP1800SxMCT3G			± 220	
		NP2100SxMCT3G			± 240	
		NP2300SxMCT3G			± 260	
		NP2600SxMCT3G			± 300	
		NP3100SxMCT3G			± 350	
		NP3500SxMCT3G			± 400	
$I_{(BO)}$	Breakover Current: The instantaneous current flowing at the breakover voltage.			800	mA	
I_H	Holding Current: Minimum current required to maintain the device in the on-state. (Notes 5, 6)	150			mA	
I_{DRM}	Off-state Current: The dc value of current that results from the application of the off-state voltage	$V_D = 50\text{ V}$			2	μA
		$V_D = V_{DRM}$			5	
V_T	On-state Voltage: The voltage across the device in the on-state condition. $I_T = 2.2\text{ A}$ (pk), PW = 300 μs , DC = 2%			4	V	
di/dt	Critical rate of rise of on-state current: rated value of the rate of rise of current which the device can withstand without damage.			± 500	A/ μs	

4. Electrical parameters are based on pulsed test methods.
5. Measured under pulsed conditions to reduce heating
6. Allow cooling before testing second polarity.

THERMAL CHARACTERISTICS

Symbol	Rating	Value	Unit
T_{STG}	Storage Temperature Range	-65 to +150	$^\circ\text{C}$
T_J	Junction Temperature	-40 to +150	$^\circ\text{C}$
$R_{\theta JA}$	Thermal Resistance: Junction-to-Ambient Per EIA/JESD51-3, PCB = FR4 3"x4.5"x0.06" Fan out in a 3x3 inch pattern, 2 oz copper track.	90	$^\circ\text{C}/\text{W}$

NPMC Series

ELECTRICAL PARAMETER/RATINGS DEFINITIONS

Symbol	Parameter
V_{DRM}	Repetitive Peak Off-state Voltage
$V_{(BO)}$	Breakover Voltage
I_{DRM}	Off-state Current
$I_{(BO)}$	Breakover Current
I_H	Holding Current
V_T	On-state Voltage
I_T	On-state Current
I_{TSM}	Nonrepetitive Peak On-state Current
I_{PPS}	Nonrepetitive Peak Impulse Current
V_D	Off-state Voltage
I_D	Off-state Current

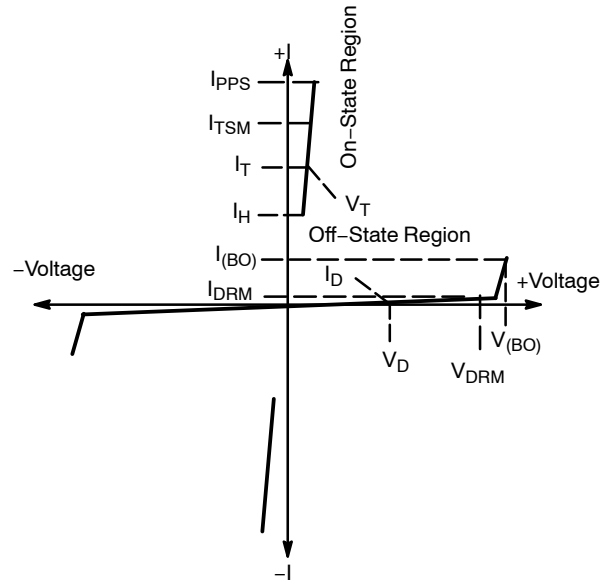

Figure 1. Voltage Current Characteristics of TSPD

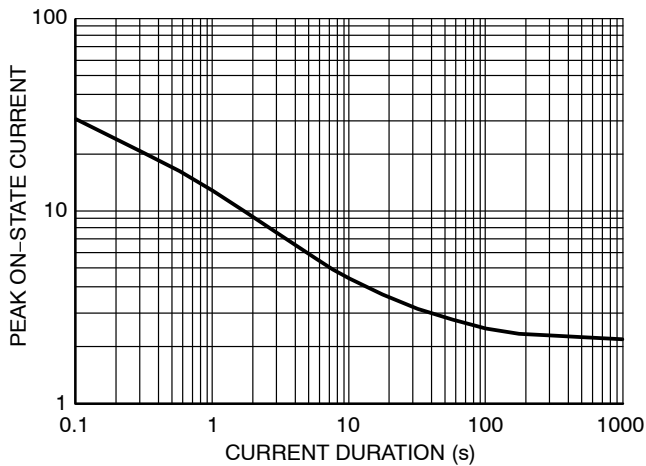

Figure 2. Nonrepetitive On-State Current vs. Time (I_{TSM})

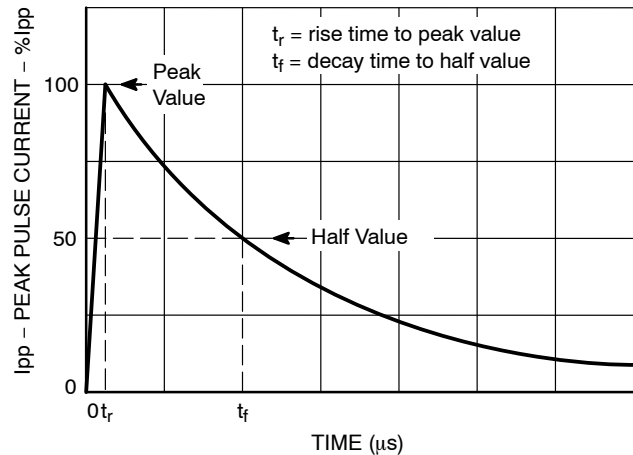

Figure 3. Nonrepetitive On-State Impulse vs. Waveform (I_{PPS})

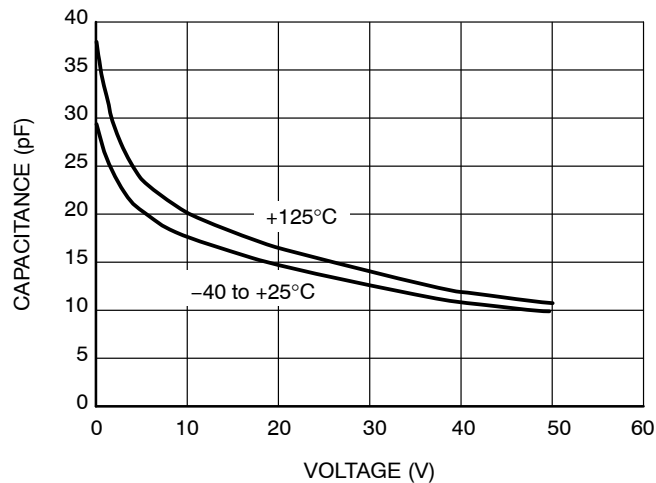

Figure 4. Capacitance vs. Off-State Voltage

Detailed Operating Description

The TSPD or Thyristor Surge Protection Device are specialized silicon based overvoltage protectors, used to protect sensitive electronic circuits from damaging overvoltage transient surges caused by induced lightning and powercross conditions.

The TSPD protects by switching to a low on state voltage when the specified protection voltage is exceeded. This is known as a “crowbar” effect. When an overvoltage occurs, the crowbar device changes from a high-impedance to a low-impedance state. This low-impedance state then offers a path to ground, shunting unwanted surges away from the sensitive circuits.

This crowbar action defines the TSPD’s two states of functionality: Open Circuit and Short Circuit.

Open Circuit – The TSPD must remain transparent during normal circuit operation. The device looks like an open across the two wire line.

Short Circuit – When a transient surge fault exceeds the TSPD protection voltage threshold, the devices switches on, and shorts the transient to ground, safely protecting the circuit.

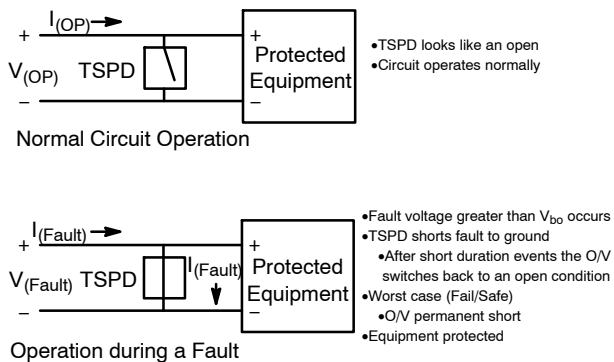

Figure 5. Normal and Fault Conditions

The electrical characteristics of the TSPD help the user to define the protection threshold for the circuit. During the open circuit condition the device must remain transparent; this is defined by the I_{DRM} . The I_{DRM} should be as low as possible. The typical value is less than 5 μA .

The circuit operating voltage and protection voltage must be understood and considered during circuit design. The $V_{(BO)}$ is the guaranteed maximum voltage that the protected circuit will see, this is also known as the protection voltage. The V_{DRM} is the guaranteed maximum voltage that will keep the TSPD in its normal open circuit state. The TSPD $V_{(BO)}$ is typically a 20–30% higher than the V_{DRM} . Based on these characteristics it is critical to choose devices which have a V_{DRM} higher than the normal circuit operating voltage, and a $V_{(BO)}$ which is less than the failure threshold of the protected equipment circuit. A low on-state voltage V_t allows the TSPD to conduct large amounts of surge current (500 A) in a small package size.

Once a transient surge has passed and the operating voltage and currents have dropped to their normal level the TSPD changes back to its open circuit state.

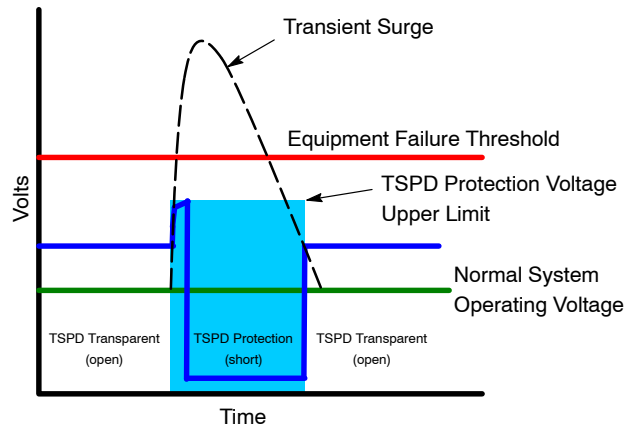

Figure 6. Protection During a Transient Surge

TSPD’s are useful in helping designers meet safety and regulatory standards in Telecom equipment including GR–1089–CORE, ITU–K.20, ITU–K.21, ITU–K.45, FCC Part 68, UL1950, and EN 60950.

ON Semiconductor offers a full range of these products in the NP series product line.

DEVICE SELECTION

When selecting a TSPD use the following key selection parameters.

Off-State Voltage V_{DRM}

Choose a TSPD that has an Off-State Voltage greater than the normal system operating voltage. The protector should not operate under these conditions:

Example:

$$V_{bat} = 48 \text{ Vmax}$$

$$V_{ring} = 150 \text{ Vrms} = 150 * 1.414 = 212 \text{ V peak}$$

V_{DRM} should be greater than the peak value of these two components:

$$V_{DRM} > 212 + 48 = 260 \text{ V}_{DRM}$$

Breakover Voltage $V_{(BO)}$

Verify that the TSPD Breakover Voltage is a value less than the peak voltage rating of the circuit it is protecting.

Example: Relay breakdown voltage, SLIC maximum voltage, or coupling capacitor maximum rated voltage.

Peak Pulse Current I_{pps}

Choose a Peak Pulse current value which will exceed the anticipated surge currents in testing. In some cases the 100 A “C” series device may be needed when little or no series resistance is used. When a series current limiter is used in the circuit a lower current level of “A” or “B” may be used. To determine the peak current divide the maximum surge current by the series resistance.

Hold Current (I_H)

The Hold Current must be greater than the maximum system generated current. If it is not then the TSPD will remain in a shorted condition, even after a transient event has passed.

NPMC Series

TYPICAL APPLICATIONS

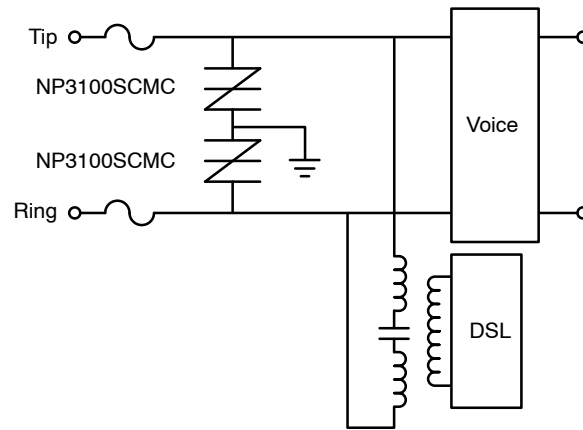

Figure 7. ADSL

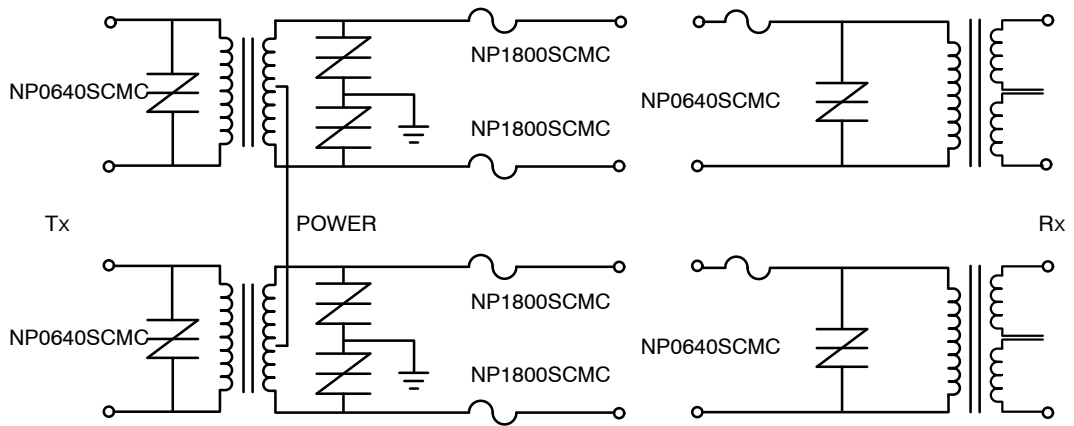
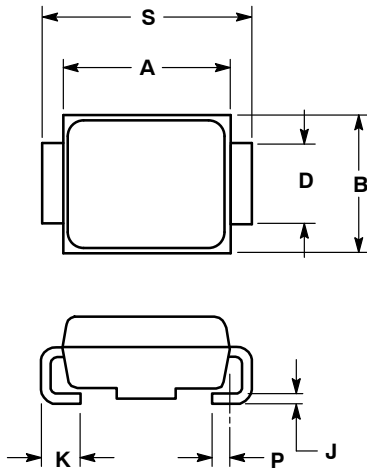

Figure 8. T1/E1

NPMC Series

PACKAGE DIMENSIONS

SMB CASE 403C-01 ISSUE A



NOTES:

1. DIMENSIONING AND TOLERANCING PER ANSI Y14.5M, 1982.
2. CONTROLLING DIMENSION: INCH.
3. D DIMENSION SHALL BE MEASURED WITHIN DIMENSION P.

DIM	INCHES		MILLIMETERS	
	MIN	MAX	MIN	MAX
A	0.160	0.180	4.06	4.57
B	0.130	0.150	3.30	3.81
C	0.075	0.095	1.90	2.41
D	0.077	0.083	1.96	2.11
H	0.0020	0.0060	0.051	0.152
J	0.006	0.012	0.15	0.30
K	0.030	0.050	0.76	1.27
P	0.020	REF	0.51	REF
S	0.205	0.220	5.21	5.59

SOLDERING FOOTPRINT*

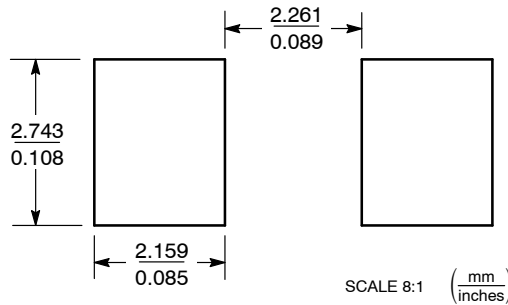

*For additional information on our Pb-Free strategy and soldering details, please download the ON Semiconductor Soldering and Mounting Techniques Reference Manual, SOLDERRM/D.

ON Semiconductor and are registered trademarks of Semiconductor Components Industries, LLC (SCILLC). SCILLC reserves the right to make changes without further notice to any products herein. SCILLC makes no warranty, representation or guarantee regarding the suitability of its products for any particular purpose, nor does SCILLC assume any liability arising out of the application or use of any product or circuit, and specifically disclaims any and all liability, including without limitation special, consequential or incidental damages. "Typical" parameters which may be provided in SCILLC data sheets and/or specifications can and do vary in different applications and actual performance may vary over time. All operating parameters, including "Typicals" must be validated for each customer application by customer's technical experts. SCILLC does not convey any license under its patent rights nor the rights of others. SCILLC products are not designed, intended, or authorized for use as components in systems intended for surgical implant into the body, or other applications intended to support or sustain life, or for any other application in which the failure of the SCILLC product could create a situation where personal injury or death may occur. Should Buyer purchase or use SCILLC products for any such unintended or unauthorized application, Buyer shall indemnify and hold SCILLC and its officers, employees, subsidiaries, affiliates, and distributors harmless against all claims, costs, damages, and expenses, and reasonable attorney fees arising out of, directly or indirectly, any claim of personal injury or death associated with such unintended or unauthorized use, even if such claim alleges that SCILLC was negligent regarding the design or manufacture of the part. SCILLC is an Equal Opportunity/Affirmative Action Employer. This literature is subject to all applicable copyright laws and is not for resale in any manner.

PUBLICATION ORDERING INFORMATION

LITERATURE FULFILLMENT:
Literature Distribution Center for ON Semiconductor
P.O. Box 5163, Denver, Colorado 80217 USA
Phone: 303-675-2175 or 800-344-3860 Toll Free USA/Canada
Fax: 303-675-2176 or 800-344-3867 Toll Free USA/Canada
Email: orderlit@onsemi.com

N. American Technical Support: 800-282-9855 Toll Free
USA/Canada
Europe, Middle East and Africa Technical Support:
Phone: 421 33 790 2910
Japan Customer Focus Center
Phone: 81-3-5773-3850

ON Semiconductor Website: www.onsemi.com
Order Literature: <http://www.onsemi.com/orderlit>
For additional information, please contact your local Sales Representative

Looking for pricing, stock, or lifecycle information?

Click below to explore more details on WIN SOURCE:

- ⊖ [View NP2600SAMCT3G on WIN SOURCE](#)
- ⊖ [ON Semiconductor Information](#)

Optimize Your Supply Chain with WIN SOURCE Solutions

- ✓ Global Sourcing Solution
- ✓ Obsolete Management
- ✓ Cost Control Management
- ✓ Shortage Management
- ✓ Alternative Solution
- ✓ Excess Inventory Management