



**THE DATASHEET OF
NLA2066USG**



NLAS2066

Ultra-Small Dual Single Pole, Single Throw Analog Switch with Over Voltage Tolerance

The NLAS2066 is a Dual SPST (Single Pole, Single Throw) Analog Switch high performance version of the popular NLAS323. Packaged in the ultra-small US8 package. It is designed as a general analog/digital switch and can also be used to isolate USB ports.

Features

- Same Pinout as the Popular NLAS323
- Excellent Performance – Maximum $R_{DS(ON)}$ 15 Ω at 3.0 V
- Matching Between the Switches $\pm 1.5 \Omega$ at 3.0 V
- 1.65 V to 5.5 V Operating Range
- Lower Threshold Voltages for LVTTTL/CMOS Levels
- Ultra-Low Charge Injection ≤ 4.8 pC at 3.0 V
- Low Standby Power – $I_{CC} = 1.0$ nA (max) @ $T_A = 25^\circ\text{C}$
- CMOS Level Compatibility
- OVT* (Pins 1, 3, 5, and 7) These Pins may be Subjected to 0 to +7.0 V, Regardless of Operating Voltage
- Allows a Short from USB Line without Damage to the Device
- These Devices are Pb-Free, Halogen Free/BFR Free and are RoHS Compliant

Typical Applications

- USB Isolation
- Cell Phones
- PDAs
- MP3s Digital Still Cameras

Important Information

- ESD Protection: Human Body Model; > 1500 V
Machine Model; > 200 V
- Latch-Up Maximum Rating: 200 mA

*Over Voltage Tolerance (OVT) enables pins to function outside (higher) of their operating voltages, with no damage to the devices or to signal integrity.



ON Semiconductor®

www.onsemi.com

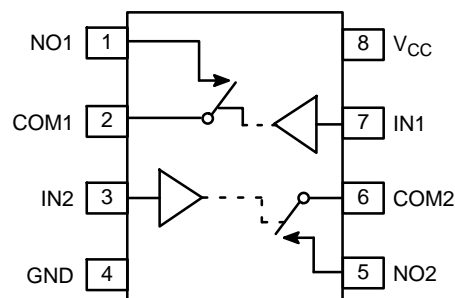
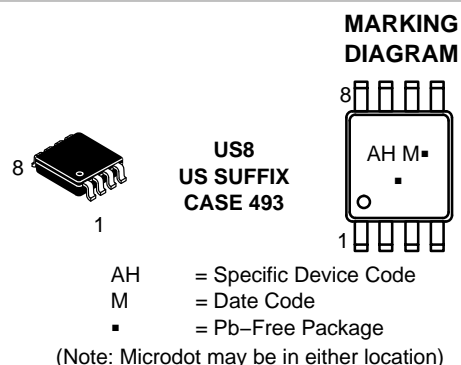

PIN ASSIGNMENT

Pin	Function	OVT
1	NO1	Yes
2	COM1	–
3	IN2	Yes
4	GND	–
5	NO2	Yes
6	COM2	–
7	IN1	Yes
8	V _{CC}	–

FUNCTION TABLE

On/Off Enable Input	State of Analog Switch
L	Off
H	On

ORDERING INFORMATION

See detailed ordering and shipping information in the package dimensions section on page 8 of this data sheet.

NLAS2066

MAXIMUM RATINGS

Symbol	Rating	Value	Unit
V _{CC}	DC Supply Voltage	- 0.5 to + 7.0	V
V _I	DC Input Voltage Pins 1, 3, 5, 7 Pins 2, 6	- 0.5 to + 7.0 - 0.5 to V _{CC}	V
V _O	DC Output Voltage	- 0.5 to + 7.0	V
I _{IK}	DC Input Diode Current V _I < GND	- 50	mA
I _{OK}	DC Output Diode Current V _O < GND	- 50	mA
I _O	DC Output Sink Current	± 50	mA
I _{CC}	DC Supply Current per Supply Pin	± 100	mA
I _{GND}	DC Ground Current per Ground Pin	± 100	mA
T _{STG}	Storage Temperature Range	- 65 to + 150	°C
T _L	Lead Temperature, 1 mm from Case for 10 Seconds	260	°C
T _J	Junction Temperature under Bias	+ 150	°C
θ _{JA}	Thermal Resistance (Note 1)	250	°C/W
P _D	Power Dissipation in Still Air at 85°C	250	mW
MSL	Moisture Sensitivity	Level 1	-
F _R	Flammability Rating Oxygen Index: 28 to 34	UL 94 V-0 @ 0.125 in	-
V _{ESD}	ESD Withstand Voltage Human Body Model (Note 2) Machine Model (Note 3) Charged Device Model (Note 4)	> 1500 > 200 N/A	V

Stresses exceeding those listed in the Maximum Ratings table may damage the device. If any of these limits are exceeded, device functionality should not be assumed, damage may occur and reliability may be affected.

1. Measured with minimum pad spacing on an FR4 board, using 10 mm-by-1 inch, 2-ounce copper trace with no air flow
2. Tested to EIA/JESD22-A114-A
3. Tested to EIA/JESD22-A115-A
4. Tested to JESD22-C101-A

RECOMMENDED OPERATING CONDITIONS

Symbol	Characteristics	Min	Max	Unit
V _{CC}	Positive DC Supply Voltage	1.65	5.5	V
V _{IN}	Digital Input Voltage (INx)	GND	5.5	V
V _{IO}	Static or Dynamic Voltage Across an Off Switch	GND	V _{CC}	V
V _{IS}	Analog Input Voltage NO COM	GND GND	5.5 V _{CC}	V
T _A	Operating Temperature Range, All Package Types	-55	+125	°C
t _r , t _f	Input Rise or Fall Time (Enable Input) V _{CC} = 3.3 V ± 0.3 V V _{CC} = 5.0 V ± 0.5 V	0 0	100 20	ns/V

Functional operation above the stresses listed in the Recommended Operating Ranges is not implied. Extended exposure to stresses beyond the Recommended Operating Ranges limits may affect device reliability.

DEVICE JUNCTION TEMPERATURE VS. TIME TO 0.1% BOND FAILURES

Junction Temperature °C	Time, Hours	Time, Years
80	1,032,200	117.8
90	419,300	47.9
100	178,700	20.4
110	79,600	9.4
120	37,000	4.2
130	17,800	2.0
140	8,900	1.0

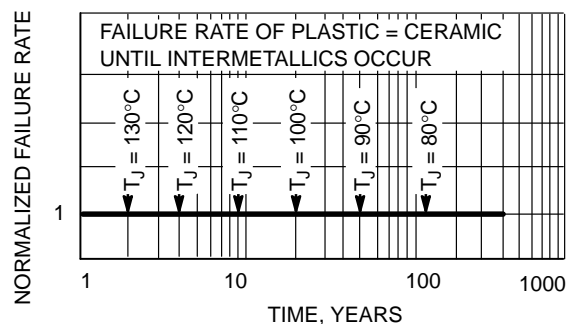

Figure 1. Failure Rate vs. Time Junction Temperature

DC CHARACTERISTICS – Digital Section (Voltages Referenced to GND)

Symbol	Parameter	Condition	V _{CC}	Guaranteed Max Limit			Unit
				25°C	-40 to 85°C	-55 to <125°C	
V _{IH}	Minimum High-Level Input Voltage, Enable Inputs		2.3 ± 10%	V _{CC} × 0.55	V _{CC} × 0.55	V _{CC} × 0.55	V
			2.7 ± 10%	V _{CC} × 0.55	V _{CC} × 0.55	V _{CC} × 0.55	
			3.0 ± 10%	V _{CC} × 0.55	V _{CC} × 0.55	V _{CC} × 0.55	
			5.0 ± 10%	V _{CC} × 0.55	V _{CC} × 0.55	V _{CC} × 0.55	
V _{IL}	Maximum Low-Level Input Voltage, Enable Inputs		2.3 ± 10%	V _{CC} × 0.30	V _{CC} × 0.30	V _{CC} × 0.30	V
			2.7 ± 10%	V _{CC} × 0.30	V _{CC} × 0.30	V _{CC} × 0.30	
			3.0 ± 10%	V _{CC} × 0.30	V _{CC} × 0.30	V _{CC} × 0.30	
			5.0 ± 10%	V _{CC} × 0.30	V _{CC} × 0.30	V _{CC} × 0.30	
I _{IN}	Maximum Input Leakage Current, Enable Inputs	V _{IN} = 5.5 V or GND	0 V to 5.5 V	±0.1	±1.0	±1.0	µA
I _{CC}	Maximum Quiescent Supply Current (per package)	Enable and V _{IS} = V _{CC} or GND	5.5	1.0	1.0	2.0	µA

Product parametric performance is indicated in the Electrical Characteristics for the listed test conditions, unless otherwise noted. Product performance may not be indicated by the Electrical Characteristics if operated under different conditions.

NLAS2066

DC ELECTRICAL CHARACTERISTICS – Analog Section

Symbol	Parameter	Condition	V _{CC}	Guaranteed Max Limit			Unit
				25°C	-40 to 85°C	-55 to <125°C	
R _{ON}	Maximum On Resistance	V _{IN} = V _{IH} I _S = 8 mA V _{IS} = V _{CC} to GND I _S = 8 mA I _S = 24 mA I _S = 32 mA (Figures 2 and 3)	2.3	50	54	54	Ω
			2.7	20	24	24	
			3.0	15	19	19	
			4.5	7	11	11	
R _{FLAT(ON)}	On Resistance Flatness	V _{IN} = V _{IH} I _S = 8 mA V _{IS} = 0 to V _{CC} I _S = 8 mA I _S = 24 mA I _S = 32 mA (Figure 5)	2.3	60	60	60	Ω
			2.7	24	24	24	
			3.0	13.5	13.5	13.5	
			4.5	3.0	3.0	3.0	
Δ R _{ON}	On Resistance Match Between Channels	V _{IS} = 1.4 V V _{IS} = 1.6 V V _{IS} = 1.8 V V _{IS} = 2.7 V (Figures 4, 5 and 6)	2.3	1.3	1.3	1.3	Ω
			2.7	1.4	1.4	1.4	
			3.0	1.5	1.5	1.5	
			4.5	2.0	2.0	2.0	
I _{NO(OFF)}	Off Leakage Current	V _{IN} = V _{IL} V _{NO} = 1.0 V, V _{COM} = 4.5 V or V _{COM} = 1.0 V and V _{NO} 4.5 V	5.5	1.0	10	100	nA
I _{COM(OFF)}	Off Leakage Current	V _{IN} = V _{IL} V _{NO} = 4.5 V or 1.0 V V _{COM} = 1.0 V or 4.5 V	5.5	1.0	10	100	nA

AC ELECTRICAL CHARACTERISTICS (Input t_r = t_f = 3.0 ns)

Symbol	Parameter	Condition	V _{CC} (V)	Guaranteed Max Limit									Unit
				25°C			-40 to 85°C			-55 to <125°C			
				Min	Typ	Max	Min	Typ	Max	Min	Typ	Max	
t _{ON}	Turn-On Time	R _L = 300 Ω, C _L = 35 pF (Figures 7, 14 and 15)	2.3		8	9			10			10	ns
			2.7		4	5			7			7	
			3.0		3	4			6			6	
			4.5		2	3			5			5	
t _{OFF}	Turn-Off Time	R _L = 300 Ω, C _L = 35 pF (Figures 7, 14 and 15)	2.3		8	10			11			11	ns
			2.7		6	8			9			9	
			3.0		5	7			8			8	
			4.5		4	6			7			7	

		Typical @ 25°C, V _{CC} = 5.0 V			Unit
C _{IN}	Maximum Input Capacitance, Select Input	3.0			pF
C _{NO} or C _{NC}	Analog I/O (Switch Off)	10			
C _{COM(OFF)}	Common I/O (Switch Off)	10			
C _{COM(ON)}	Feedthrough (Switch Off)	10			

NLAS2066

ADDITIONAL APPLICATIONS CHARACTERISTICS (Voltage Reference to GND Unless Noted)

Symbol	Parameter	Condition	V _{CC} (V)	Typical 25°C	Unit
BW	Maximum On-Channel -3.0 dB Bandwidth or Minimum Frequency Response	V _{IS} = 0 dBm (Figure 8 and 9)	2.3 2.7 3.0 4.5	102 175 180 186	MHz
V _{ONL}	Maximum Feed-Through On Loss	V _{IS} = 0 dBm @ 10 kHz (Figure 8 and 9)	2.3 2.7 3.0 4.5	-2.2 -0.9 -0.8 -0.4	dB
V _{ISO}	Off-Channel Isolation	f = 100 kHz V _{IS} = 1.0 V RMS (Figure 10 and 11)	2.3 2.7 3.0 4.5	-73 -74 -74 -75	dB
Q	Charge Injection Enable Input to Common I/O	V _{IS} = V _{CC} to GND, F _{IS} = 20 kHz (Figure 12)	3.0 5.5	4.8 7.4	pC
THD	Total Harmonic Distortion TDH + Noise	F _{IS} = 10 Hz to 100 kHz, R _L = R _{gen} = 600 Ω, C _L = 50 pF (Figure 13)	3.0 5.5	0.19 0.06	%

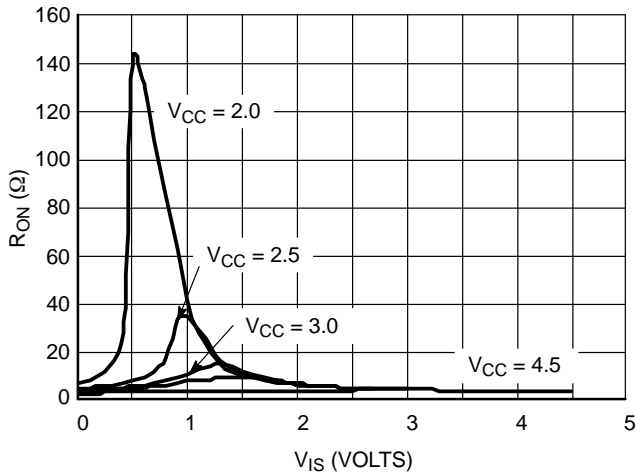

Figure 2. R_{ON} vs. V_{COM} and V_{CC} (@25°C)

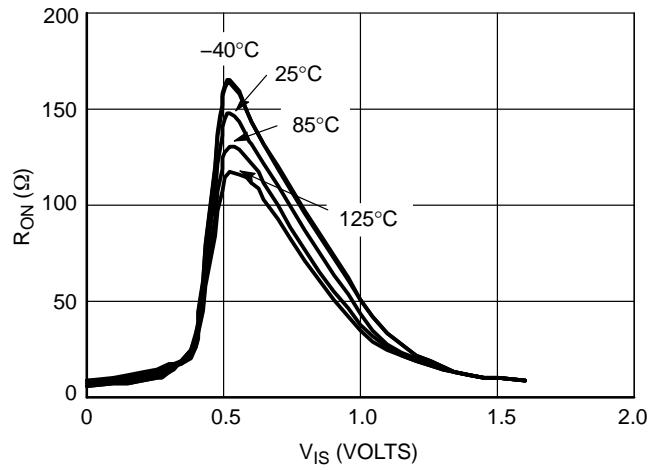

Figure 3. R_{ON} vs. V_{COM} and Temperature, $V_{CC} = 2.0$ V

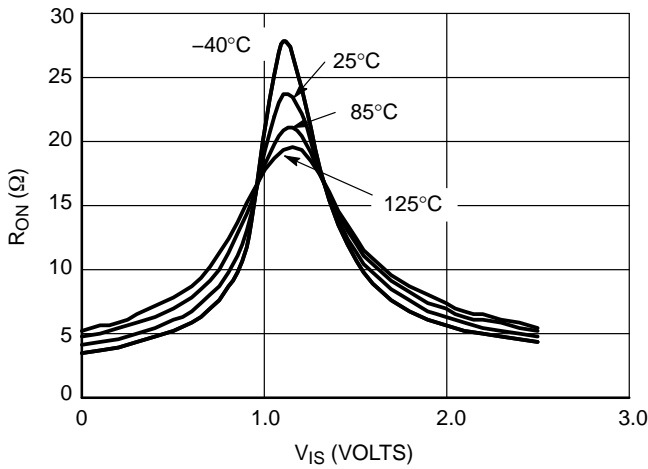

Figure 4. R_{ON} vs. V_{COM} and Temperature, $V_{CC} = 2.5$ V

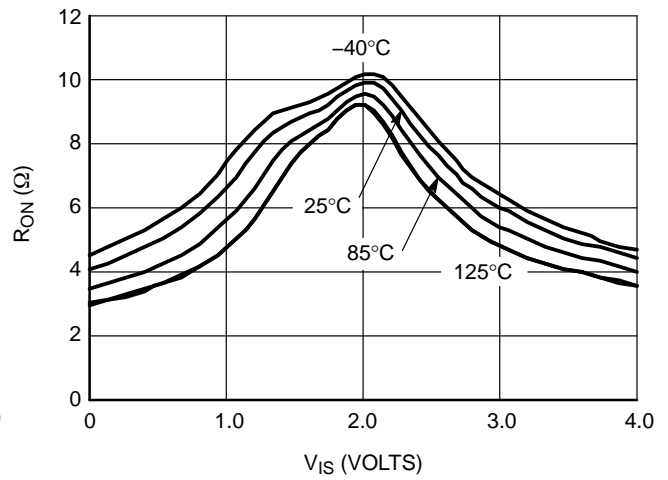

Figure 5. R_{ON} vs. V_{COM} and Temperature, $V_{CC} = 3.0$ V

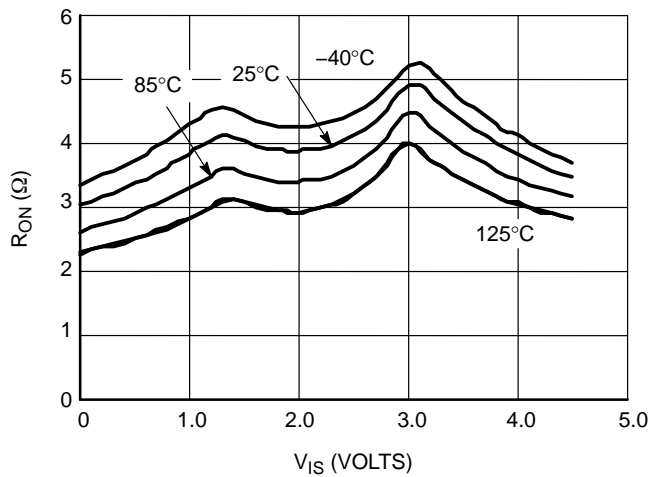

Figure 6. R_{ON} vs. V_{COM} and Temperature, $V_{CC} = 4.5$ V

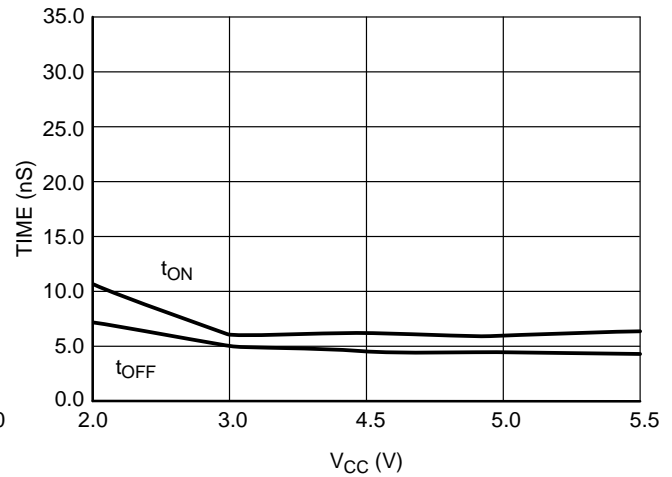

Figure 7. Switching Time vs. Supply Voltage, $T = 25^\circ\text{C}$

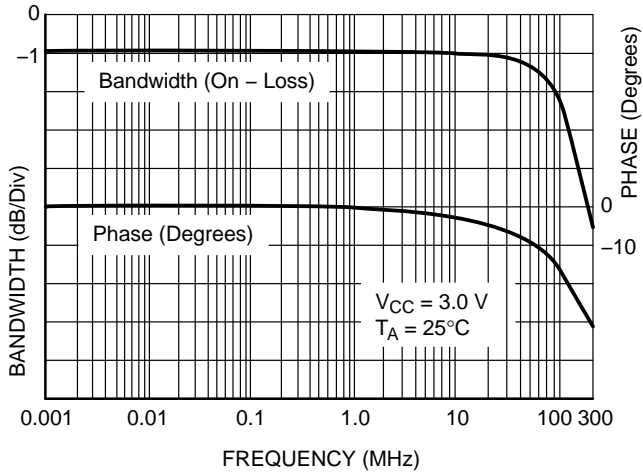

Figure 8. ON Channel Bandwidth and Phase Shift Over Frequency

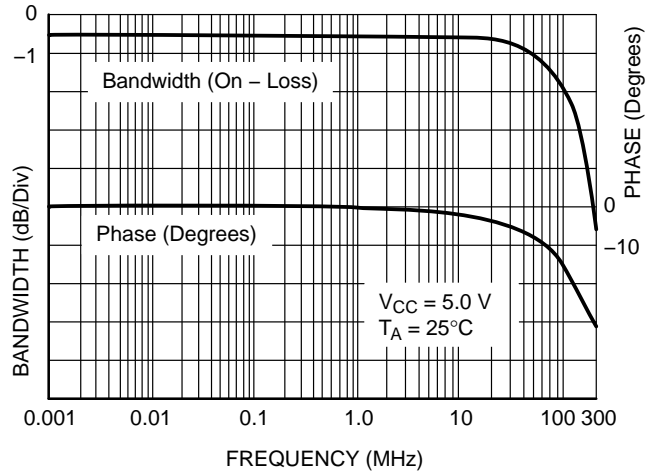

Figure 9. ON Channel Bandwidth and Phase Shift Over Frequency

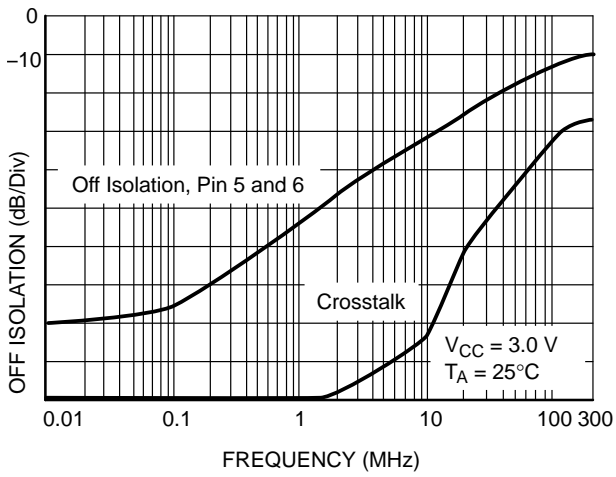

Figure 10. Off Isolation and Crosstalk

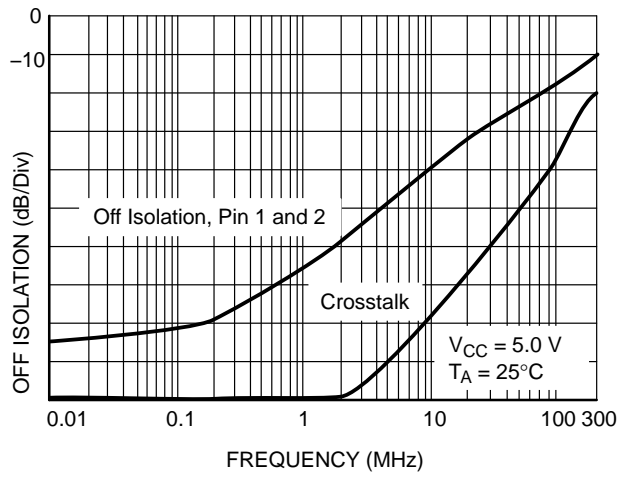

Figure 11. Off Isolation and Crosstalk

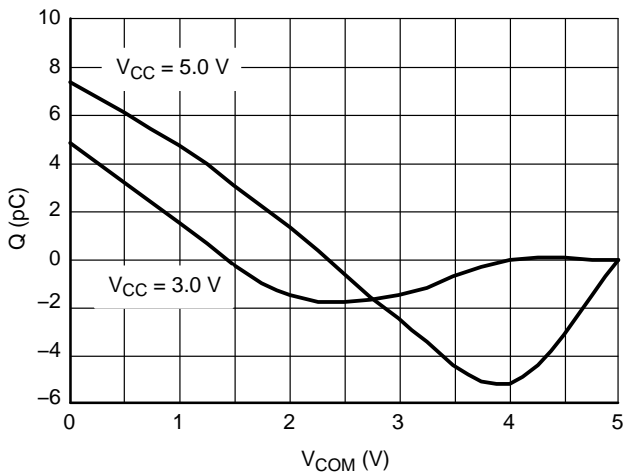

Figure 12. Charge Injection vs. V_{COM}

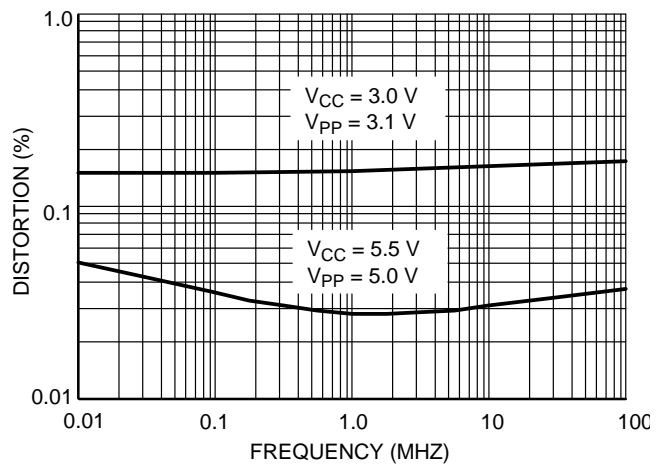

Figure 13. THD vs. Frequency

NLAS2066

TIMING INFORMATION

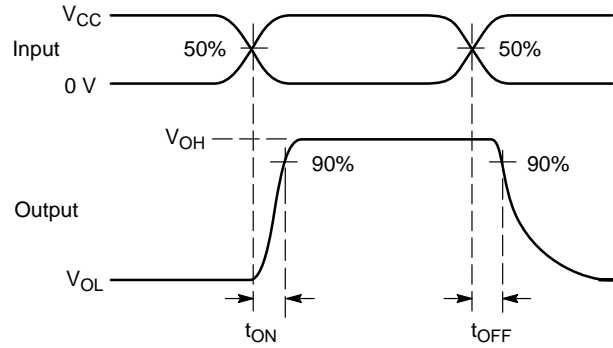
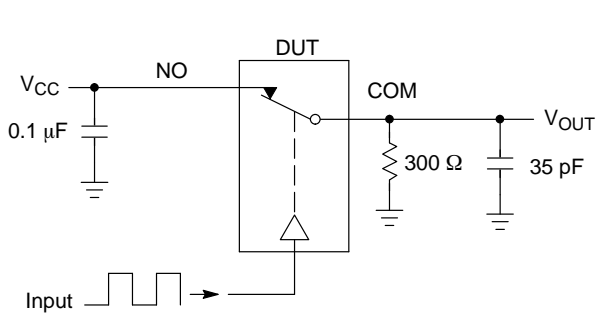

Figure 14. t_{ON}/t_{OFF}

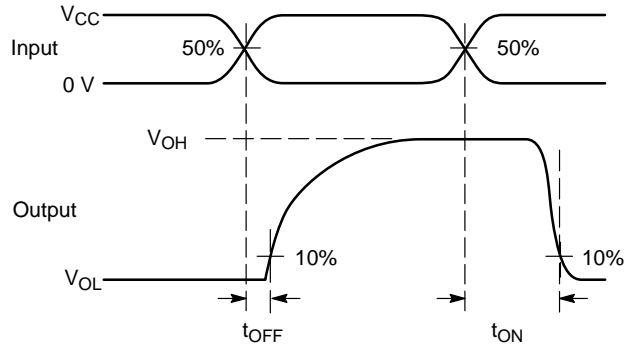
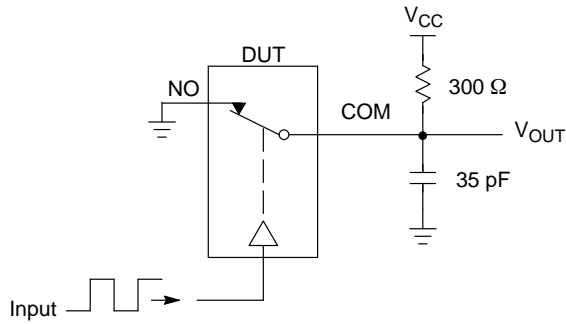

Figure 15. t_{ON}/t_{OFF}

V_{CC}	VMI
2.0 V	1.0 V
3.0 V	1.5 V
4.5 V	1.5 V

DEVICE ORDERING INFORMATION

Device Order Number	Package	Shipping†
NLAS2066USG	US8 (Pb-Free)	3,000 / Tape & Reel
NLAS2066UST3G	US8 (Pb-Free)	10,000 / Tape & Reel

†For information on tape and reel specifications, including part orientation and tape sizes, please refer to our Tape and Reel Packaging Specifications Brochure, BRD8011/D.

NLAS2066

PACKAGE DIMENSIONS

US8 US SUFFIX CASE 493-02 ISSUE D

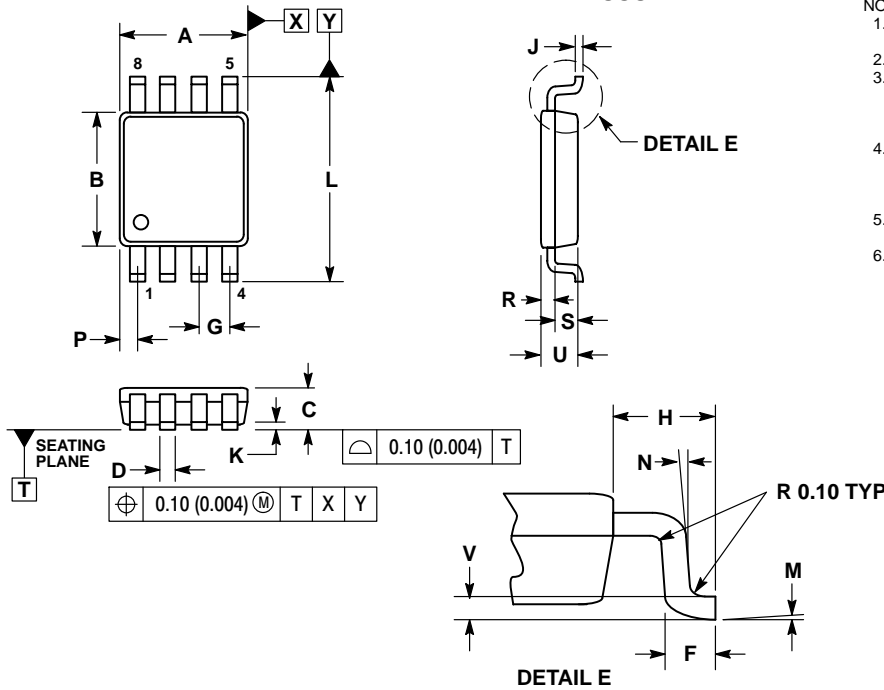

NOTES:

1. DIMENSION AND TOLERANCING PER ANSI Y14.5M, 1982.
2. CONTROLLING DIMENSION: MILLIMETERS.
3. DIMENSION A DOES NOT INCLUDE MOLD FLASH, PROTRUSION OR GATE BURR. MOLD FLASH, PROTRUSION AND GATE BURR SHALL NOT EXCEED 0.14MM (0.0055") PER SIDE.
4. DIMENSION B DOES NOT INCLUDE INTERLEAD FLASH OR PROTRUSION. INTERLEAD FLASH AND PROTRUSION SHALL NOT EXCEED 0.14MM (0.0055") PER SIDE.
5. LEAD FINISH IS SOLDER PLATING WITH THICKNESS OF 0.0076-0.0203MM (0.003-0.008").
6. ALL TOLERANCE UNLESS OTHERWISE SPECIFIED ±0.0508MM (0.0002").

DIM	MILLIMETERS		INCHES	
	MIN	MAX	MIN	MAX
A	1.90	2.10	0.075	0.083
B	2.20	2.40	0.087	0.094
C	0.60	0.90	0.024	0.035
D	0.17	0.25	0.007	0.010
F	0.20	0.35	0.008	0.014
G	0.50 BSC		0.020 BSC	
H	0.40 REF		0.016 REF	
J	0.10	0.18	0.004	0.007
K	0.00	0.10	0.000	0.004
L	3.00	3.20	0.118	0.128
M	0°	6°	0°	6°
N	0°	10°	0°	10°
P	0.23	0.34	0.010	0.013
R	0.23	0.33	0.009	0.013
S	0.37	0.47	0.015	0.019
U	0.60	0.80	0.024	0.031
V	0.12 BSC		0.005 BSC	

RECOMMENDED SOLDERING FOOTPRINT*

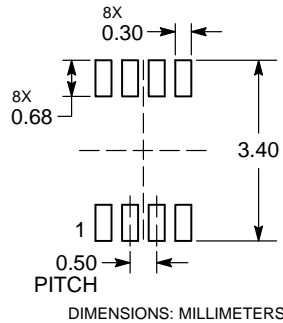

*For additional information on our Pb-Free strategy and soldering details, please download the ON Semiconductor Soldering and Mounting Techniques Reference Manual, SOLDERRM/D.

ON Semiconductor and the  are registered trademarks of Semiconductor Components Industries, LLC (SCILLC) or its subsidiaries in the United States and/or other countries. SCILLC owns the rights to a number of patents, trademarks, copyrights, trade secrets, and other intellectual property. A listing of SCILLC's product/patent coverage may be accessed at www.onsemi.com/site/pdf/Patent-Marking.pdf. SCILLC reserves the right to make changes without further notice to any products herein. SCILLC makes no warranty, representation or guarantee regarding the suitability of its products for any particular purpose, nor does SCILLC assume any liability arising out of the application or use of any product or circuit, and specifically disclaims any and all liability, including without limitation special, consequential or incidental damages. "Typical" parameters which may be provided in SCILLC data sheets and/or specifications can and do vary in different applications and actual performance may vary over time. All operating parameters, including "Typicals" must be validated for each customer application by customer's technical experts. SCILLC does not convey any license under its patent rights nor the rights of others. SCILLC products are not designed, intended, or authorized for use as components in systems intended for surgical implant into the body, or other applications intended to support or sustain life, or for any other application in which the failure of the SCILLC product could create a situation where personal injury or death may occur. Should Buyer purchase or use SCILLC products for any such unintended or unauthorized application, Buyer shall indemnify and hold SCILLC and its officers, employees, subsidiaries, affiliates, and distributors harmless against all claims, costs, damages, and expenses, and reasonable attorney fees arising out of, directly or indirectly, any claim of personal injury or death associated with such unintended or unauthorized use, even if such claim alleges that SCILLC was negligent regarding the design or manufacture of the part. SCILLC is an Equal Opportunity/Affirmative Action Employer. This literature is subject to all applicable copyright laws and is not for resale in any manner.

PUBLICATION ORDERING INFORMATION

LITERATURE FULFILLMENT:
Literature Distribution Center for ON Semiconductor
P.O. Box 5163, Denver, Colorado 80217 USA
Phone: 303-675-2175 or 800-344-3860 Toll Free USA/Canada
Fax: 303-675-2176 or 800-344-3867 Toll Free USA/Canada
Email: orderlit@onsemi.com

N. American Technical Support: 800-282-9855 Toll Free
USA/Canada
Europe, Middle East and Africa Technical Support:
Phone: 421 33 790 2910
Japan Customer Focus Center
Phone: 81-3-5817-1050

ON Semiconductor Website: www.onsemi.com
Order Literature: <http://www.onsemi.com/orderlit>
For additional information, please contact your local
Sales Representative

Looking for pricing, stock, or lifecycle information?

Click below to explore more details on WIN SOURCE:

- ⊖ [View NLAS2066USG](#) on WIN SOURCE
- ⊖ [ON Semiconductor](#) Information

Optimize Your Supply Chain with WIN SOURCE Solutions

- ✓ Global Sourcing Solution
- ✓ Obsolete Management
- ✓ Cost Control Management
- ✓ Shortage Management
- ✓ Alternative Solution
- ✓ Excess Inventory Management