

DUAL H BRIDGE DRIVER

■ GENERAL DESCRIPTION

The NJM2670 is a general-purpose 60V dual H-bridge drive IC. It consists of a pair of H-bridges, a thermal shut down circuit and its alarm output. The alarm output can detect application problems and the system reliability will be significantly improved if monitored by Micro Processor.

Therefore, it is suitable for two-phase stepper motor application driven by microprocessor.

■ PACKAGE OUTLINE

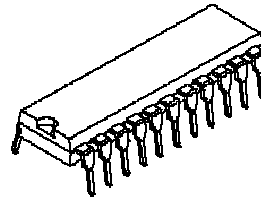

NJM2670D2

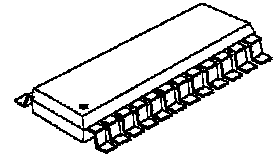

NJM2670E3

■ FEATURES

- Wide Voltage Range (4V to 60V)
- Wide Range of Current Control (5 to 1500mA)
- Thermal overload Protection
- Dead Band Protector
- Package Outline (DIP-22, EMP-24)

■ PIN CONNECTION

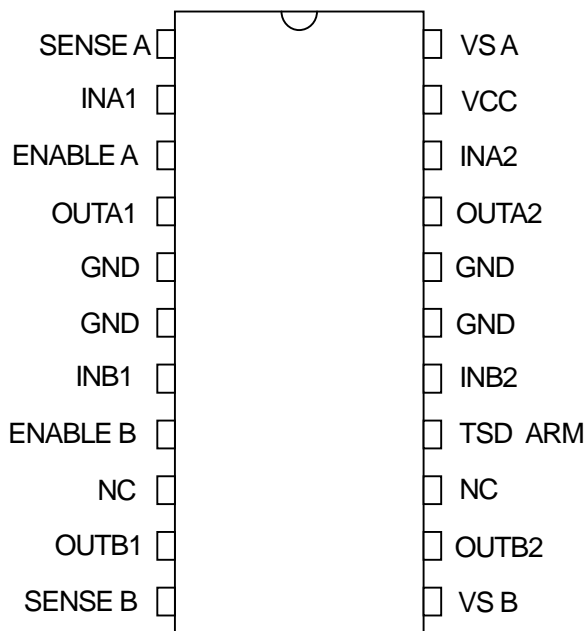

DIP-22

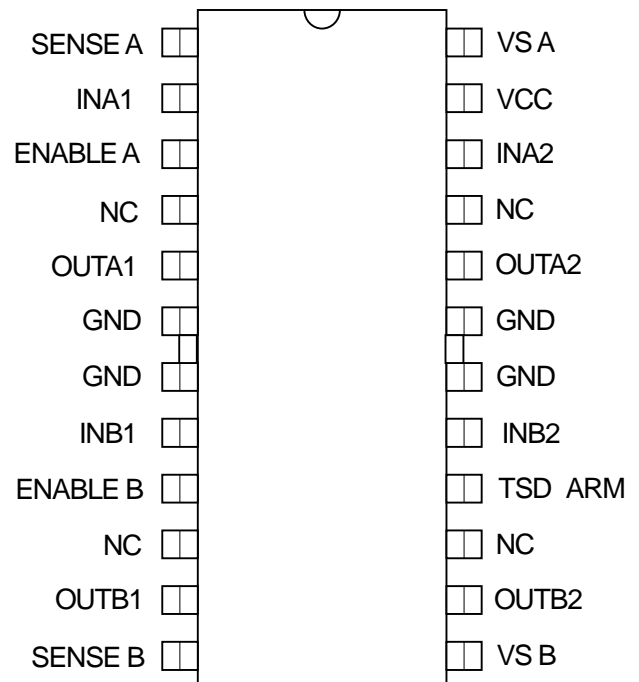

EMP-24

NJM2670

■ BLOCK DIAGRAM

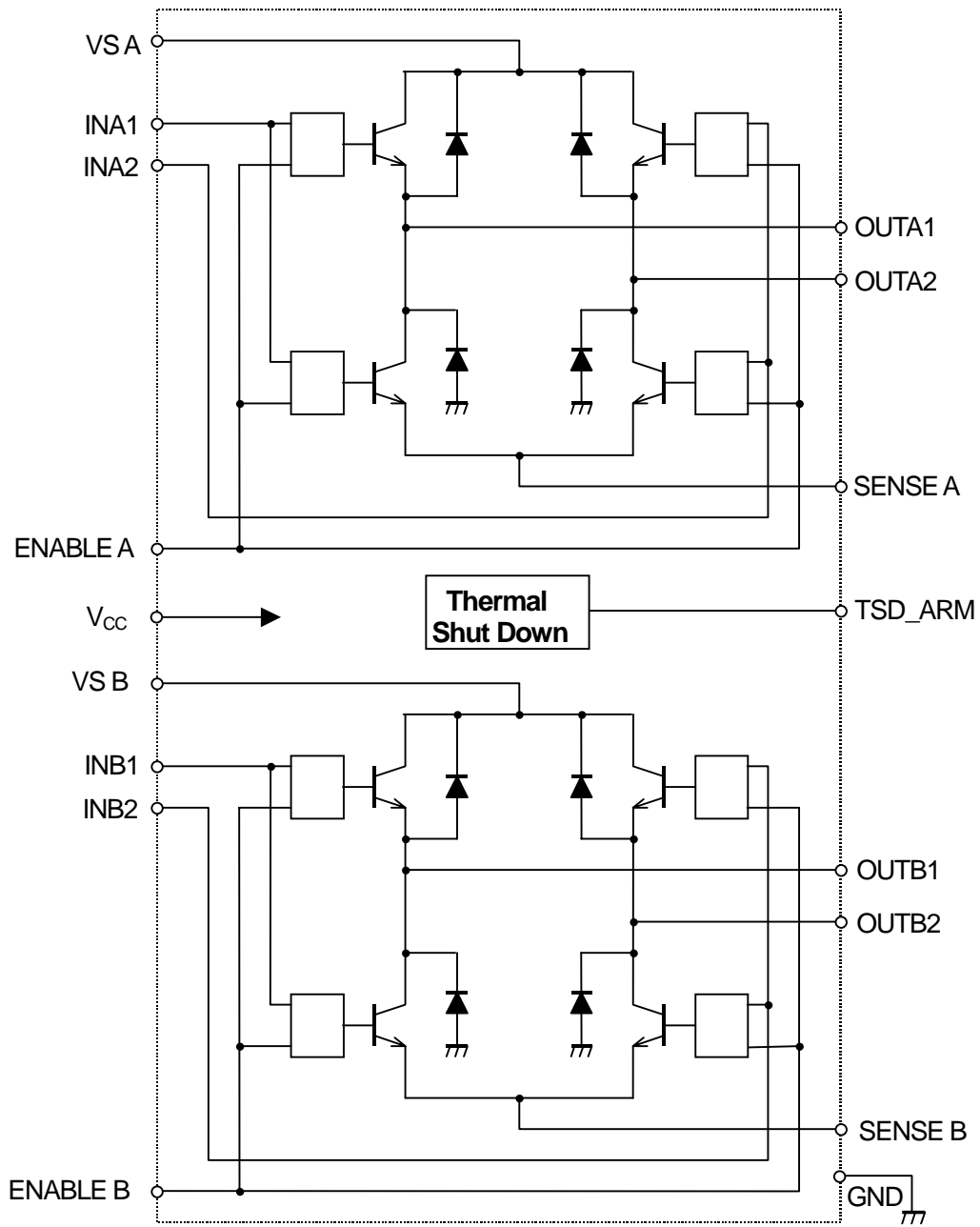

■ ABSOLUTE MAXIMUM RATINGS (Ta=25°C)

PARAMETER	SYMBOL	RATINGS	UNIT
Maximum Supply Voltage	V_{MM}	60	V
Logic Supply Voltage	V_{CC}	7	V
Input Voltage Range	V_{IN}	-0.3 to 7	V
Output Current	I_{OUT}	1.5	A
Power Dissipation@T(GND)=25°C	P_{D25}	5	W
Power Dissipation@T(GND)=125°C	P_{D125}	2	W
Operating Junction Temperature	T_{opr}	-40 ~ 85	°C
Storage Temperature	T_{stg}	-55 ~ 150	°C

■ RECOMENENDO OPERATING CONDITIONS

PARAMETER	SYMBOL	TEST CONDITIONS	MIN.	TYP.	MAX.	UNIT
Supply Voltage	V_{MM}		4	-	55	V
Logic Voltage Range	V_{CC}		4.75	5.00	5.25	V
Maximum Output Current	I_{OUT}		-	-	1.3	A
Total Power Dissipation	P_D	$T_{GND}=25^\circ\text{C}$	-	-	5	W
	P_D	$T_{GND}=125^\circ\text{C}$	-	-	2.2	W

■ THERMAL CHARACTERISTICS

PARAMETER	SYMBOL	TEST CONDITIONS	MIN.	TYP.	MAX.	UNIT
Thermal resistance	$R_{th_{j-GND}}$	DIP22 package.	-	11	-	°C/W
	$R_{th_{j-A}}$	DIP22 package. Note	-	40	-	°C/W
	$R_{th_{j-GND}}$	EMP24 package.	-	13	-	°C/W
	$R_{th_{j-A}}$	EMP24 package. Note	-	42	-	°C/W

Note : All ground pins soldered onto a 20 cm² PCB copper area with free air convection, $T_A=+25^\circ\text{C}$

NJM2670

■ ELECTRICAL CHARACTERISTICS

PARAMETER	SYMBOL	TEST CONDITIONS	MIN.	TYP.	MAX.	UNIT
GENERAL						
Quiescent current	I _{CC}	Enable=H, IN1=IN3=L, IN2=IN4=H	-	40	-	mA
Thermal shutdown	T _{SD}		-	170	-	°C
Off-State leak current	I _{tsd-LEAK}	TSD ARM=5V	-	-	50	μA
Thermal alarm output saturation	V _{tsd}	I _o =5mA	-	0.5	0.7	V
Dead time protection	T _d		-	1	-	μs
LOGIC						
Input LOW voltage	V _{IL}		-	-	0.6	V
Input HIGH voltage	V _{IH}		2	-	-	V
Input HIGH current	I _{IH}	V _i =2.4V	-	-	20	μA
Input LOW current	I _{IL}	V _i =0.4V	-0.4	-	-	mA
OUTPUT						
Upper transistor saturation	V _{OU1}	I _o =1000mA	-	1.3	1.5	V
	V _{OU2}	I _o =1300mA	-	1.5	1.8	V
Lower transistor saturation	V _{OL1}	I _o =1000mA	-	0.5	0.8	V
	V _{OL2}	I _o =1300mA	-	0.8	1.3	V
Upper diode forward	V _{IU1}	I _o =1000mA	-	1.3	1.6	V
	V _{IU2}	I _o =1300mA	-	1.6	1.9	V
Lower diode forward	V _{IL1}	I _o =1000mA	-	1.3	1.6	V
	V _{IL2}	I _o =1300mA	-	1.6	1.9	V
Output leakage current	I _{LO-LEAK}	V _{MM} =50V	-	-	1	mA
Upper diode recovery time	T _{rrU}		-	250	-	ns
Lower diode recovery time	T _{rrL}		-	250	-	ns

■ TRUTH TABLE

INPUT (L=Low, H=High, X=Don't care)			OUTPUT (H=Source, L=Sink)		OUTPUT mode
ENABLE A=H ENABLE B=H	INA1 INB1	INA2 INB2	OUTA1 OUTB1	OUTA2 OUTB2	
	L	L	L	L	short break mode
	L	H	L	H	CW
	H	L	H	L	CCW
	H	H	H	H	short break mode
ENABLE A=L ENABLE B=L	X	X	All Transistor turned OFF		

■ TYPICAL APPLICATION

1). Bipolar Stepper Motor

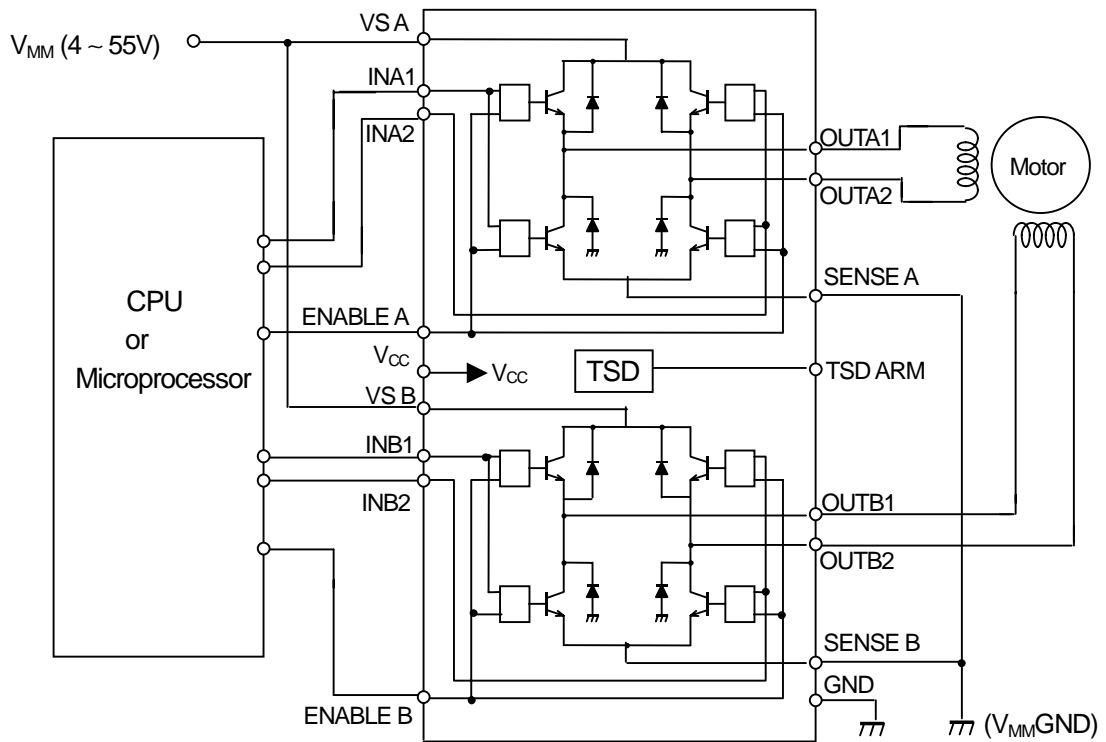

2). Single Phase DC Motor

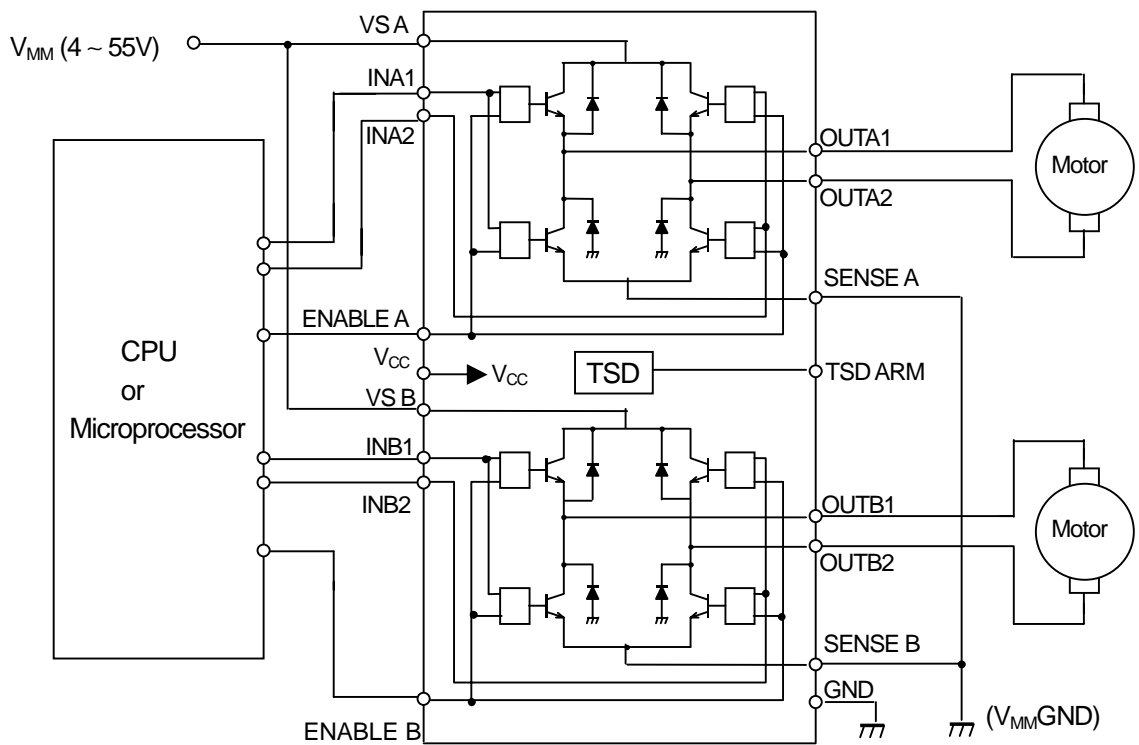

NJM2670

3) Current Control Application for Bipolar Stepper Motor

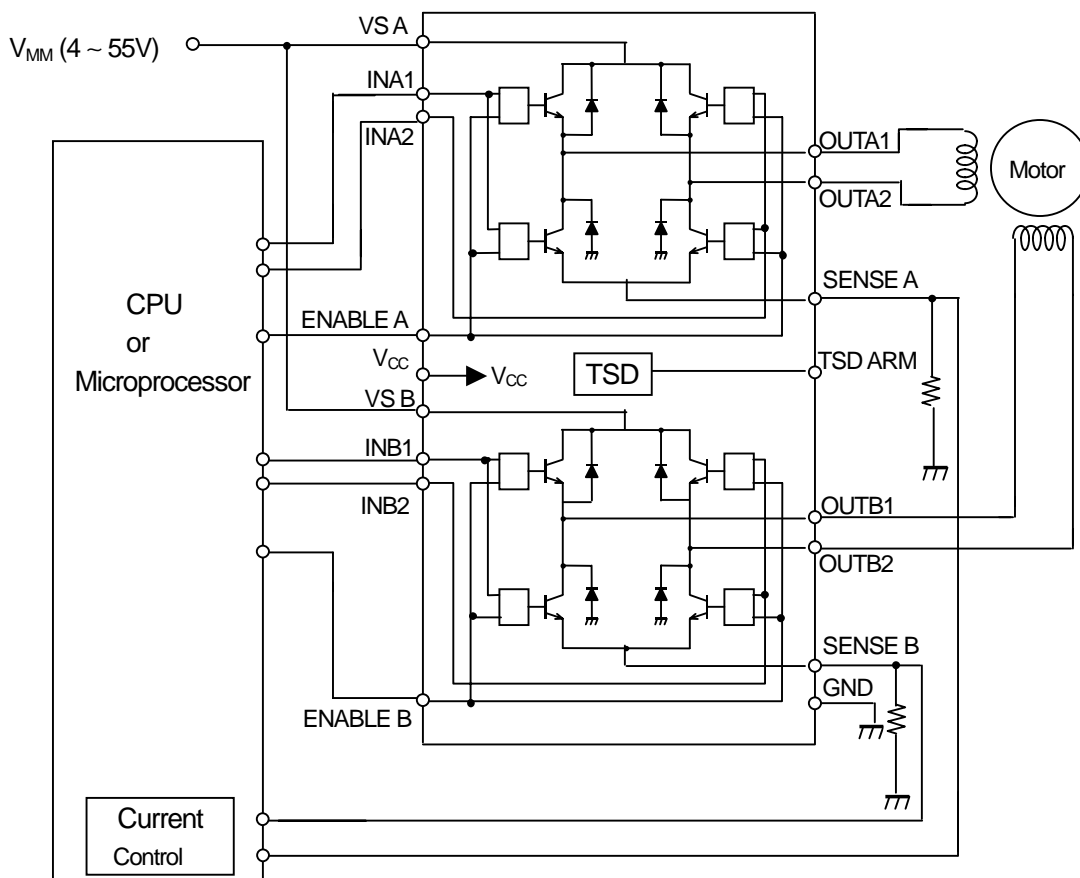

■ TIMING CHART

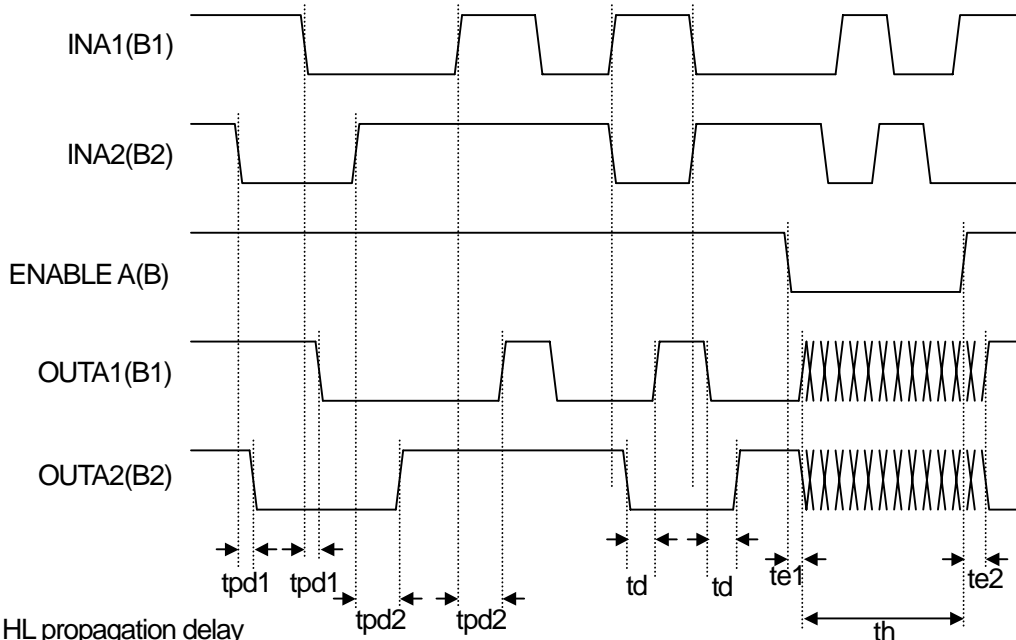

tpd1:IN_HL propagation delay

tpd2:IN_LH propagation delay

td :Output dead band protection delay

te1 :ENABLE_HL propagation delay

te2 :ENABLE_LH propagation delay

th :Output High impedance section

	Reference value	unit
tpd1	1.0	us
tpd2	2.5	us
td	1.5	us
te1	3.5	us
te2	2.0	us

TYPICAL APPLICATION 1

ICC vs. VCC

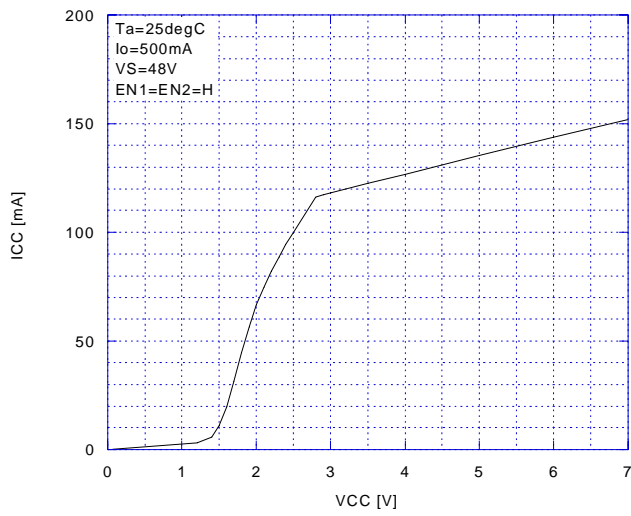

VIN(INA1)-hysteresis vs. Temperature

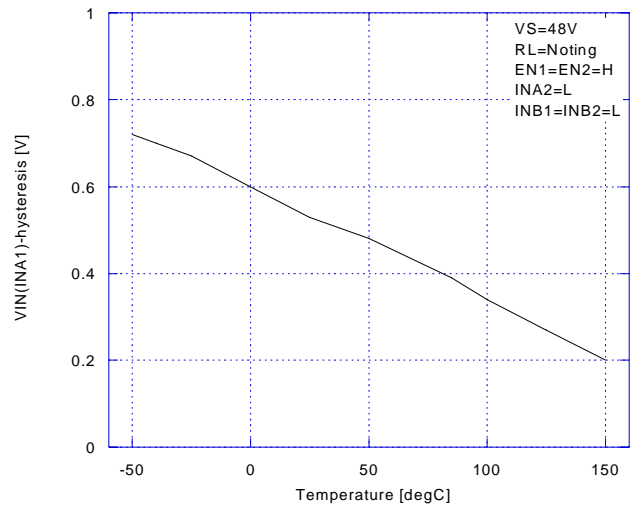

VIN(INA1) vs. Temperature

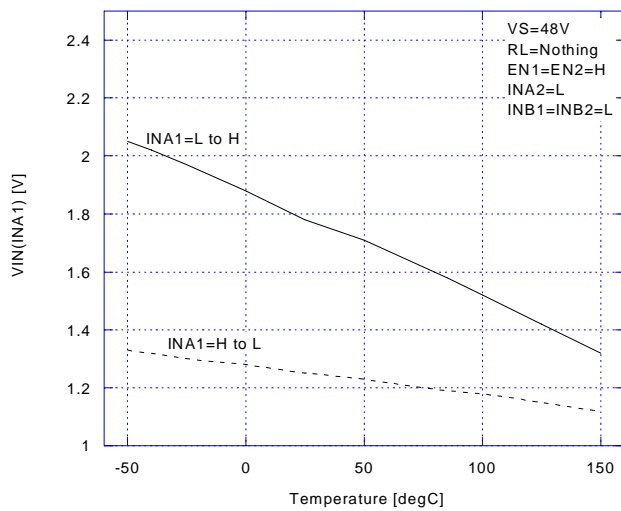

VIN(INA1)-IB vs. Temperature

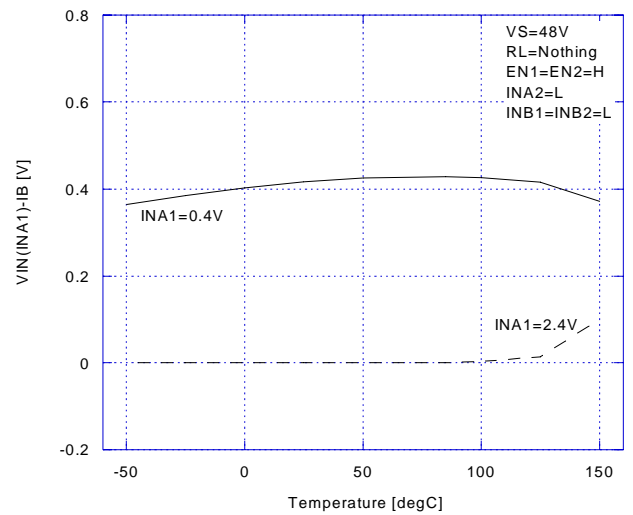

Vsat(D) vs. Io

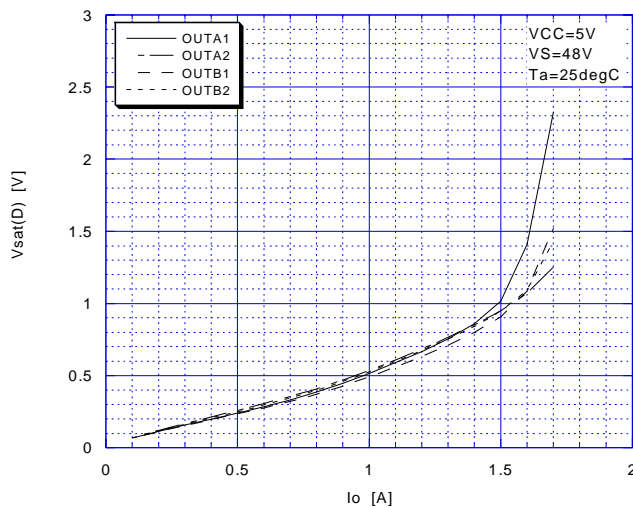

Vsat(U) vs. Io

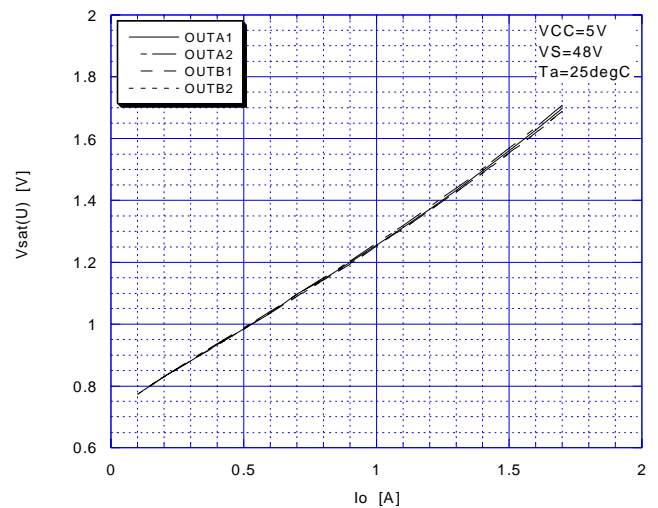

NJM2670

TYPICAL APPLICATION 2

Diode(D) vs. I_o

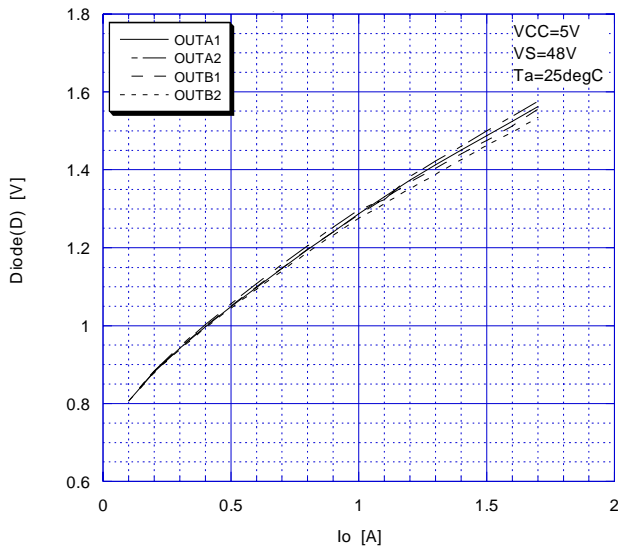

Diode(U) vs. I_o

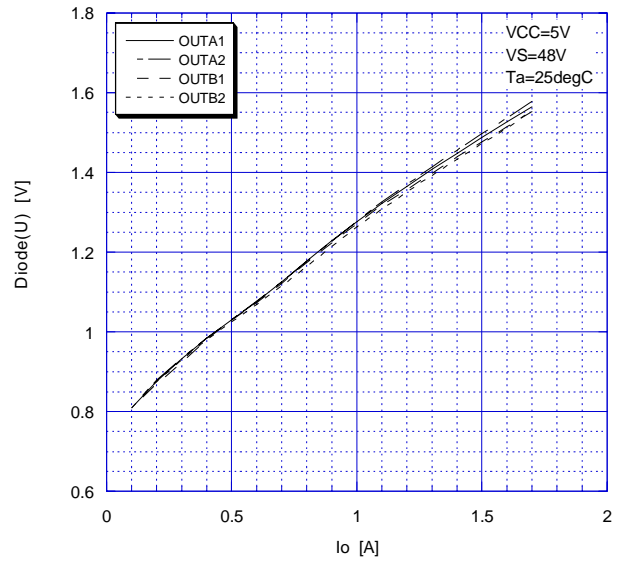

ICC vs. Temperature

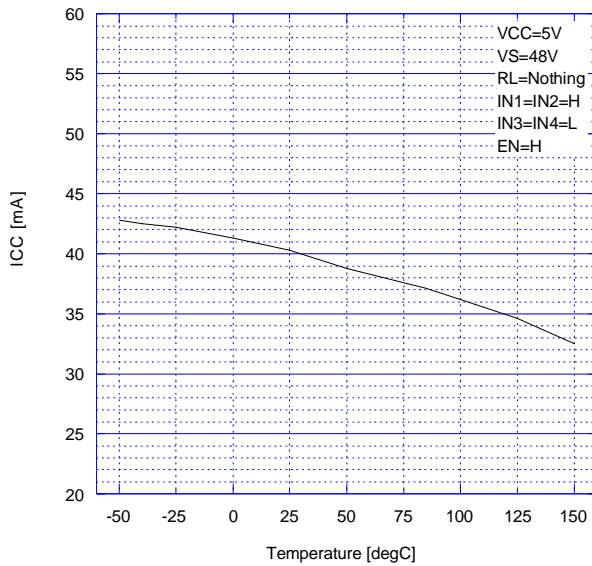

ICC vs. Temperature

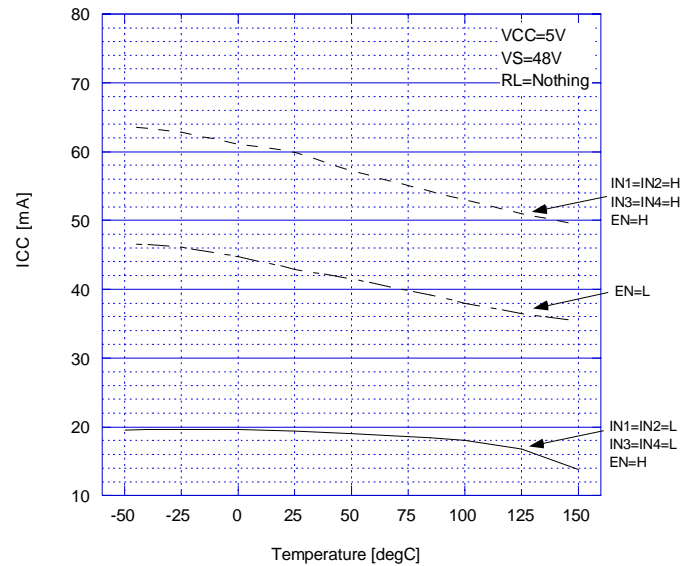

Vsat(D) vs. Temperature

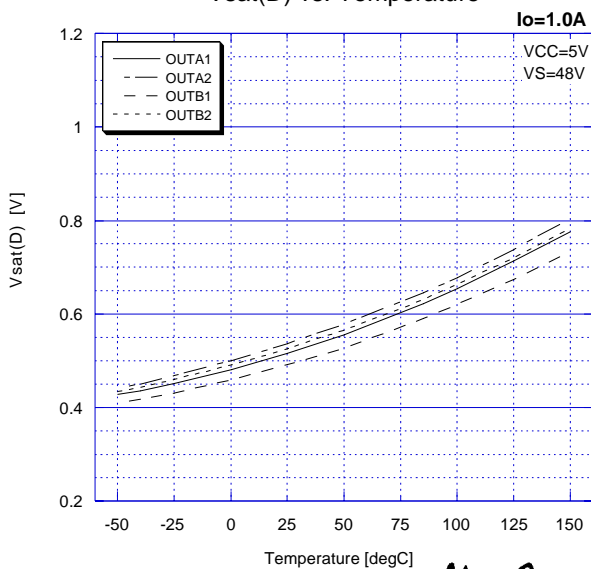

Vsat(U) vs. Temperature

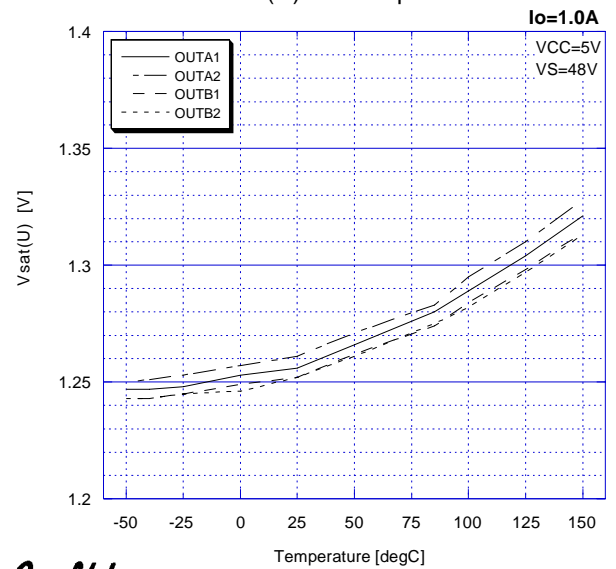

TYPICAL APPLICATION 3

Vsat(D) vs. Temperature

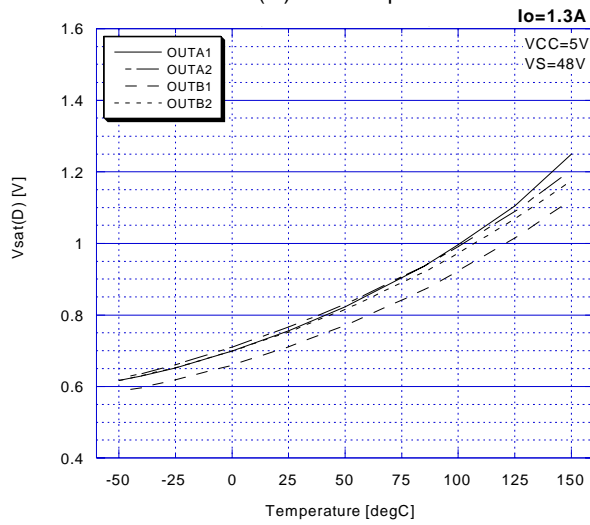

Vsat(U) vs. Temperature

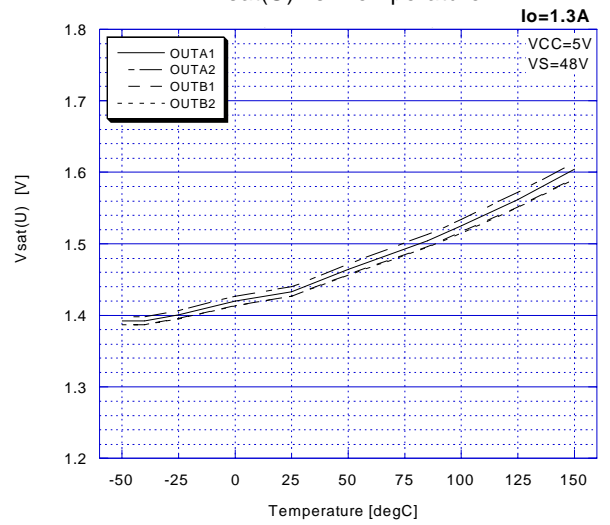

Diode(D) vs. Temperature

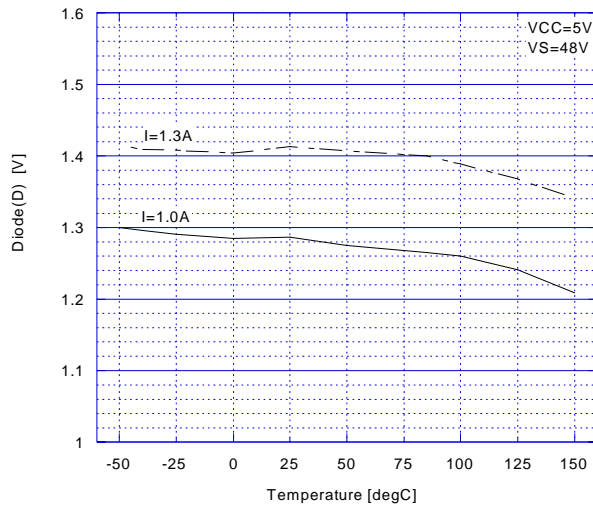

Diode(U) vs. Temperature

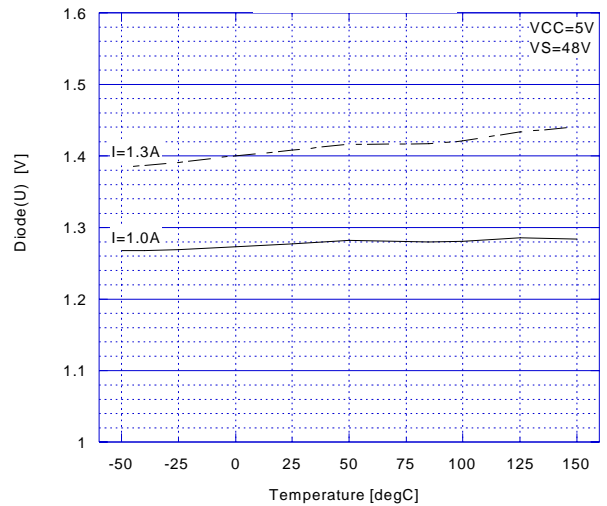

Diode(U) vs. Temperature

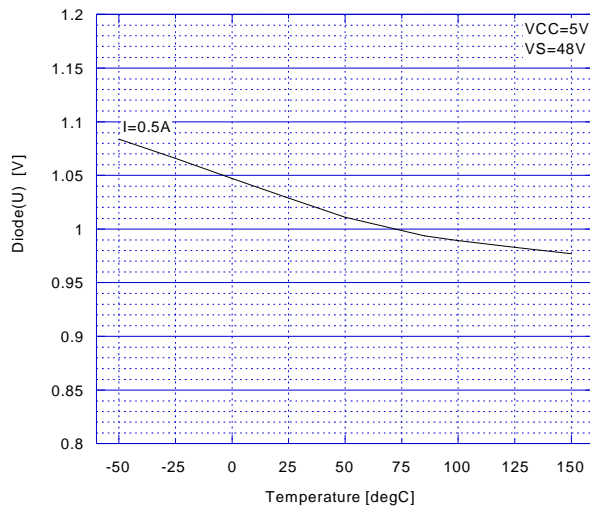



[CAUTION]

The specifications on this databook are only given for information, without any guarantee as regards either mistakes or omissions. The application circuits in this databook are described only to show representative usages of the product and not intended for the guarantee or permission of any right including the industrial rights.

Looking for pricing, stock, or lifecycle information?

Click below to explore more details on WIN SOURCE:

-  [View NJM2670D2 on WIN SOURCE](#)
-  [NJR Corporation/NJRC Information](#)

Optimize Your Supply Chain with WIN SOURCE Solutions

-  Global Sourcing Solution
-  Obsolete Management
-  Cost Control Management
-  Shortage Management
-  Alternative Solution
-  Excess Inventory Management