

50MHz INPUT MIXER AND 450kHz FM IF DEMODULATOR IC

■ GENERAL DESCRIPTION

The **NJM2593** is an FM IF demodulator IC with 450kHz (standard) IF frequency, which operates from 1.8V to 9V supply, low-current. It includes an oscillator, mixer, limiting amplifier, quadrature detector, active filter, and FSK comparator.

The **NJM2593** also has a RSSI circuit and RSSI comparator for carrier sense.

■ PACKAGE OUTLINE

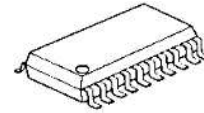

NJM2593V

■ FEATURES

- Wide Operating Voltage 1.8V to 9.0V
- Low Operating Current 1.2mA type. at $V^+ = 2.0V$, external local oscillator input
- Maximum Mixer Input Signal
 - Frequency 50MHz (reference value)
- Mixer Input Resistance 4.5k Ω (reference value)
- IF Frequency 450kHz (standard)
- Conventional Quadrature Detector
 - External Phase-shifting Capacitor
 - External Discriminator or LC Resonant Circuit
- RSSI Comparator with Open-Collector Output
- Quick Charge/Discharge Circuit for FSK Reference Voltage
- Bipolar Technology
- Package Outline SSOP20

■ BLOCK DIAGRAM

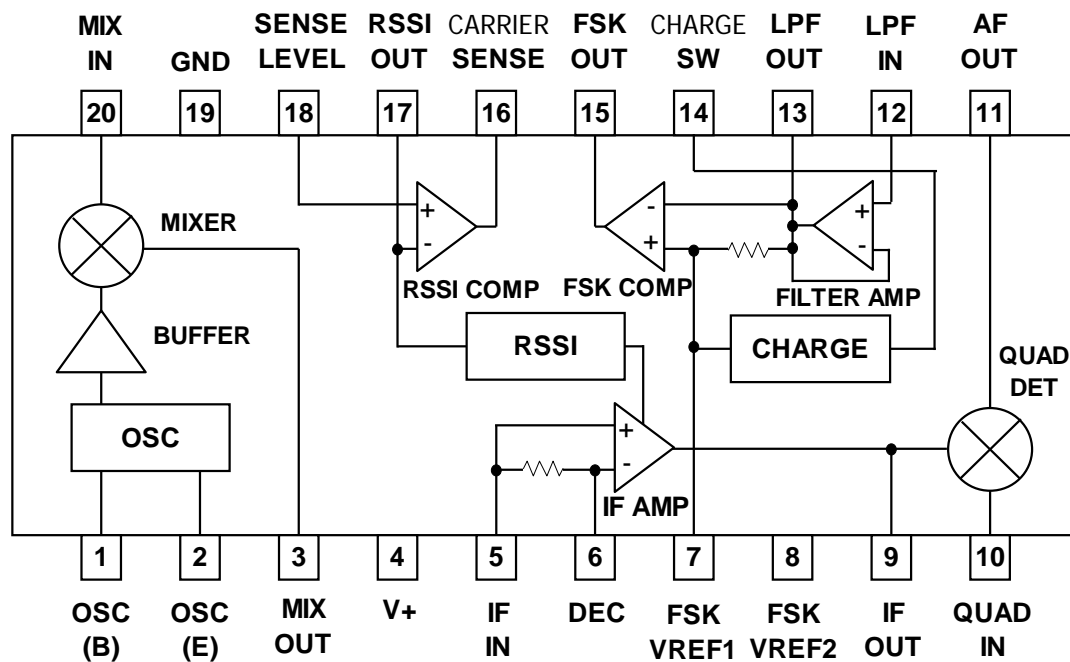

NJM2593

■ ABSOLUTE MAXIMUM RATINGS

(Ta=25°C)

PARAMETER	SYMBOL	RATINGS	UNIT
Supply Voltage	V ⁺	10.0	V
Power Dissipation	P _d	300	mW
Operating Temperature	T _{opr}	- 40 to +85	°C
Storage Temperature	T _{stg}	- 40 to +125	°C

■ RECOMMENDED OPERATING CONDITION

(Ta=25°C)

PARAMETER	SYMBOL	TEST CONDITIONS	MIN.	TYP.	MAX.	UNIT
Supply Voltage	V ⁺		1.8	2.0	9.0	V

■ ELECTRICAL CHARACTERISTICS

(Ta=25°C, V⁺=2.0V, f_{mix}=21.7MHz, f_{lo}=21.25MHz, f_{if}=450kHz, f_{mod}=600Hz, f_{dev}=±2kHz, unless otherwise noted)

PARAMETER	SYMBOL	TEST CONDITIONS	MIN.	TYP.	MAX.	UNIT
Current Consumption	I _{ccq}	No signal	-	1.2	1.5	mA
Mixer Conversion Gain	G _{mix}	V _{inMIX} =60dBuVEMF, Measured at Pin3, without IF filter, with 1.8kΩ+0.1uF	17	20	23	dB
Mixer 3rd Order Intercept	IP3		-	95	-	dBuV
Mixer Input Resistance	R _{inM}		-	4.5	-	kΩ
Mixer Input Capacitance	C _{inM}		-	2.0	-	pF
Mixer Output Resistance	R _{oM}		-	1.8	-	kΩ
Signal to Noise Ratio 1	S/N1	Mixer input V _{inMIX} =60dBuVEMF	-	60	-	dB
Signal to Noise Ratio 2	S/N2	IF input V _{inIF} =60dBuVEMF	40	60	70	dB
Signal to Noise Ratio 3	S/N3	IF input V _{inIF} =25dBuVEMF	20	30	40	dB
-3dB Limiting Sensitivity	V _{in(lim)}	IF input	-	22	-	dBuVEMF
AM Rejection Ratio	AMR	IF input, AM=30% V _{inIF} =60dBuVEMF	-	50	-	dB
IF Amplifier Input Resistance	R _{inIF}		-	1.8	-	kΩ
RSSI Output Voltage	V _{rssi}	IF input V _{inIF} =40dBuVEMF	0.35	0.5	0.65	V

PARAMETER	SYMBOL	TEST CONDITIONS	MIN.	TYP.	MAX.	UNIT
Demodulated Output Level	Vod	IF input VinIF =60dBuVEMF	70	80	90	mVrms
Duty Ratio of Wave Shaped Output	DR	IF Input VinIF=60dBuVEMF	40	50	60	%
Quick Charge/Discharge Current	Ich	FSK REF=GND LPFOUT=0.4V	35	65	110	uA
High Level Leak Current of CARRIER SENSE Terminal	IcryH	V _{CARRIER SENSE} =V ⁺	-	0.0	-	uA
Low Level Voltage of CARRIER SENSE Terminal	VcryL	I _{CARRIER SENSE} =100uA	-	0.1	0.4	V
Bias Current of SENSE LEVEL Terminal	Ilevel	V _{CARRIER SENSE} =0.8V	-	0.0	-	uA
High Level Leak Current of FSK OUT Terminal	IfskH	V _{FSK OUT} =V ⁺	-	0.0	-	uA
Low Level Voltage of FSK OUT Terminal	VfskL	I _{FSK OUT} =100uA	-	0.1	0.4	V

NJM2593

■ TEST CIRCUIT

This test circuit allows the measurement of all parameters described in "ELECTRICAL CHARACTERISTICS". This test circuit includes some electrical switches that should be in the suitable position for the measurement of each parameter.

● Test Circuit 1 (except for Gmix)

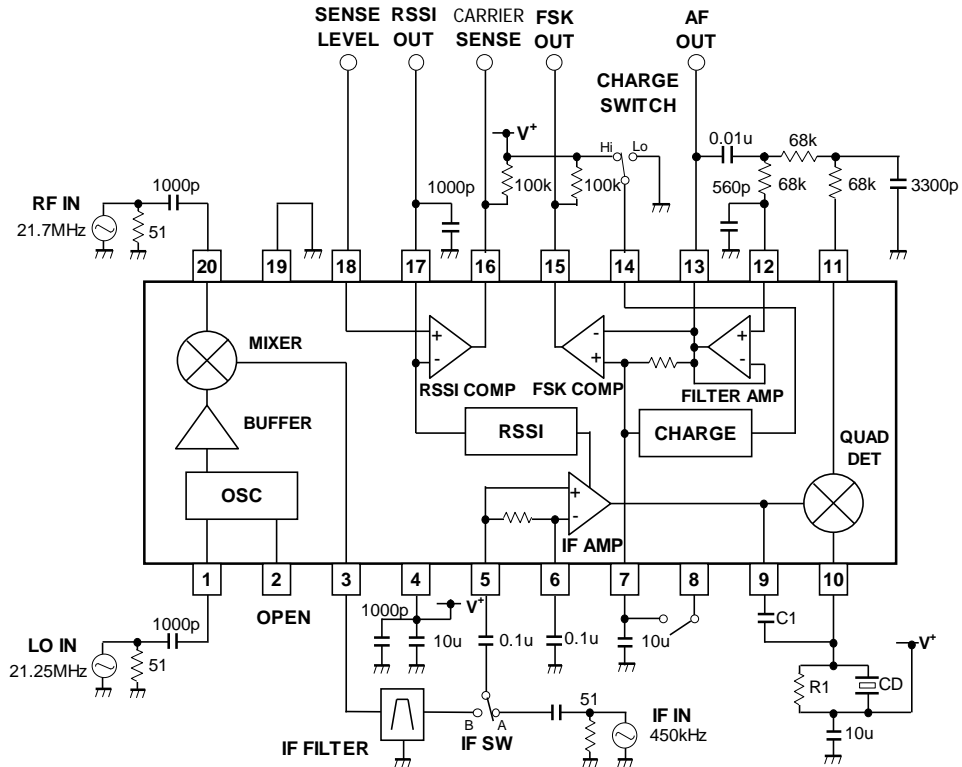

● Test Circuit 2 (for Gmix)

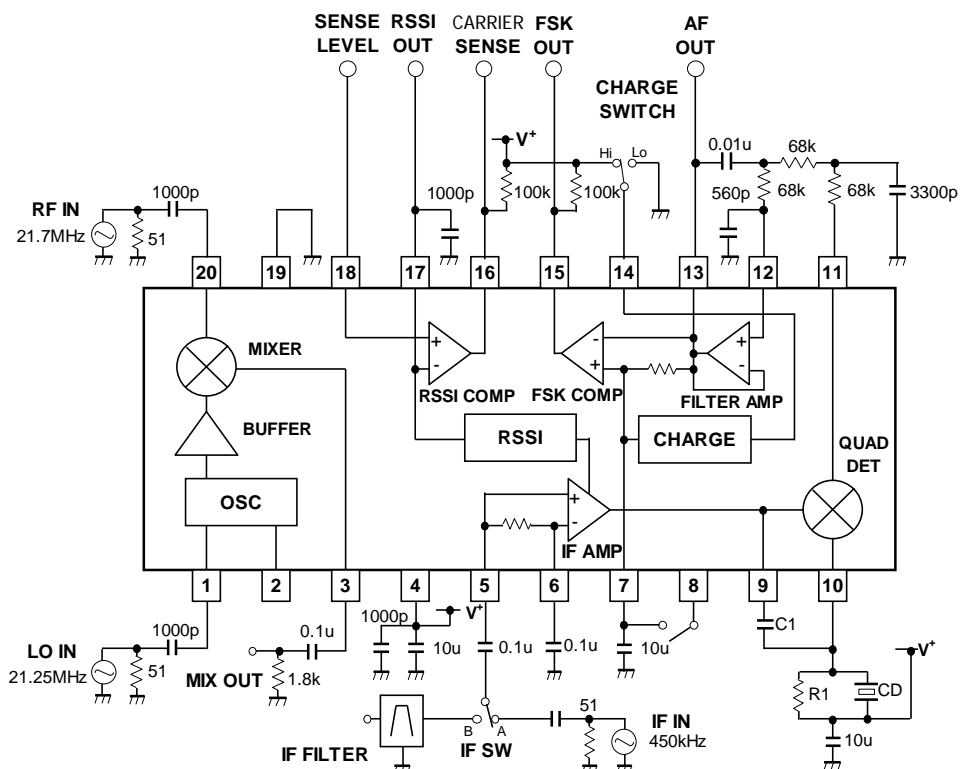

- **External components**

CD : Ceramic Discriminator, 450kHz

IF FILTER : Ceramic Filter, 450kHz

- **Measurement condition**

“Condition1” is the condition for the case of IF input :

IF SW : in the A position.

IF IN input signal : input frequency(f_{if}) = 450kHz, input level(V_{inIF})= 60dBuVEMF,
modulation frequency(f_{mod})=600Hz, deviation $f_{dev}=\pm 2$ kHz

“Condition 2” is the condition for the case of Mixer Input :

IF SW : in the B position

MIX IN input signal: input frequency(f_{mix})=21.7MHz, input level(V_{inMIX})=60dBuVEMF,
modulation frequency(f_{mod})=600Hz, deviation $f_{dev}=\pm 2$ kHz

OSC(E)input signal: input frequency(f_{osc})=21.25MHz, input level(V_{inOSC})=105dBuVEMF

NJM2593

■ TERMINAL FUNCTION (Ta=25°C, V+=2.0V)

Pin No.	SYMBOL	EQUIVALENT CIRCUIT	VOLTAGE	FUNCTION
1	OSC (B)		1.98V	Base / Emitter Terminal Colpitts - type oscillator is formed with an external oscillator element of crystal unit or SAW resonator. Output of an external oscillator circuit can also input to pin1 or pin2.
2	OSC (E)		1.28V	
3	MIX OUT		1.18V	Mixer Output An external 450kHz ceramic filter is connected. The typical output impedance is 2kΩ.
4	V+	-	-	Supply Voltage
5	IF IN		1.96V	IF Limiter Amplifier Input This is an input to the IF amplifier after passing through 450kHz ceramic filter. The typical input impedance is 1.8kΩ.
6	DEC		1.96V	IF Decoupling An external decoupling capacitor is connected to enhance stability.
7	FSK VREF1		0.46V	FSK Reference Input This pin is an input of reference voltage for FSK comparator. An external capacitor is connected to create an average DC level of FM demodulated signal. The choice of this capacitor is dependent on the speed of data signal. A quick charge/discharge circuit offers the voltage of pin 7 comes the same voltage of pin 11 quickly.

Pin No.	SYMBOL	EQUIVALENT CIRCUIT	VOLTAGE	FUNCTION
8	FSK VREF2		0.44V	FSK Reference Voltage Output This pin usually keeps open. This fixed output voltage may be available for the FSK reference voltage of wave shaping comparator by connecting to pin7. This usage is effective in shaping the data signal with continuous bits of the same polarity, and discussed in another document related to applications information.
9	IF OUT		1.14V	IF Output An external phase - shifting capacitor is connected between pin9 and pin10.
10	QUAD IN		1.99V	Quadrature Detector Input An external phase - shifting coil or ceramic discriminator is connected.
11	AF OUT		0.44V	FM Demodulated Signal Output An external 3rd order multiple feed - back filter (RC filter) is connected between pin11 and pin13.

Pin No.	SYMBOL	EQUIVALENT CIRCUIT	VOLTAGE	FUNCTION
12	LPF IN		0.45V	Low Pass Filter Input An external RC components forms a band pass filter between pin12 and pin13. This terminal is biased from pin 11 through an external RC filter.
13	LPF OUT		0.45V	Low Pass Filter Output
14	CHARGE SW		--	Quick Charge / Discharge Control The power supply output voltage to pin 14 sets up the quick charge / discharge circuit. Hi : ON Low : OFF Instead of V+, another power source can also be used within the limit of the rated supply voltage.
15	FSK OUT		--	FSK Output The FSK comparator is a wave shaping circuit. A Filter Amplifier output signal is inverted and wave shaped. Instead of V+, another power source can also be used within the limit of the rated supply voltage.
16	CARRIER SENSE		--	Carrier Sense Output This pin outputs the result of RSSI comparator by comparing RSSI output level with an external input level to pin 18.

Pin No.	SYMBOL	EQUIVARENT CIRCUIT	VOLTAGE	FUNCTION
17	RSSI OUT		0.02V	Received Signal Strength Indicator Output Pin 11 outputs DC level proportional to the log of input signal level to pin 20.
18	SENSE LEVEL		--	Sense Level Input External reference voltage of RSSI comparator
19	GND		--	Ground
20	MIX IN		1.03V	Mixer Input The mixer is designed to work up to 470MHz with the typical input impedance of $R_{inM} = 4.5k\Omega$ and $C_{inM} = 2pF$ (at 21.7MHz).

Note :

1. ESD protection diodes exist between each of the following pins and V^+ .
Pin 1,2,3,5,6,7,8,9,10,11,12,13,17,18,20
2. ESD protection diodes also exist between each of the following pins and ground.
Pin 1,2,3,5,6,7,8,9,10,11,12,13,14,15,16,17,18

NJM2593

APPLICATION CIRCUIT

- Local Oscillator with External Crystal and LC Resonant Elements

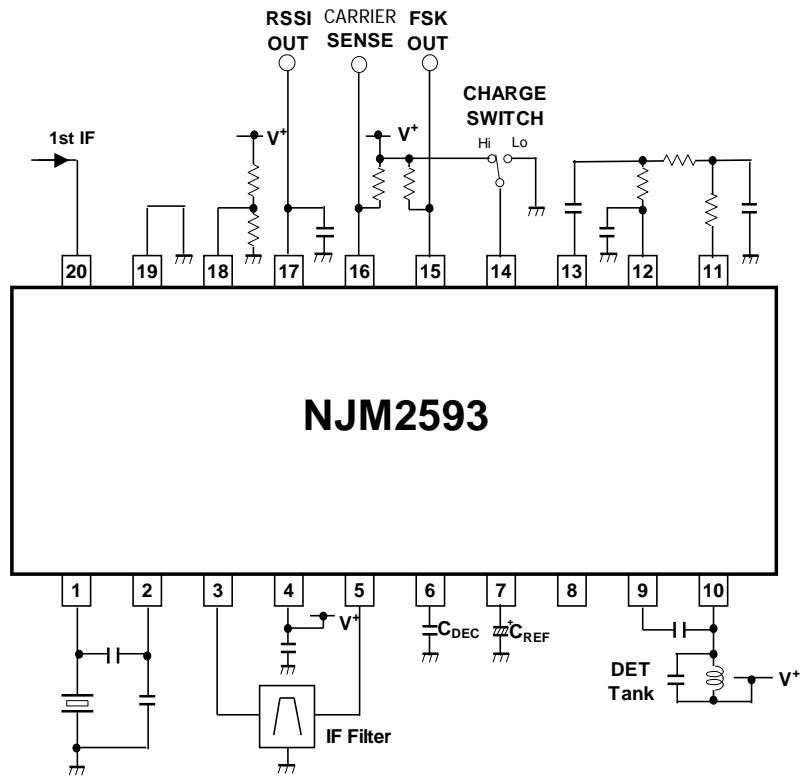

- External Local Oscillator Signal Input

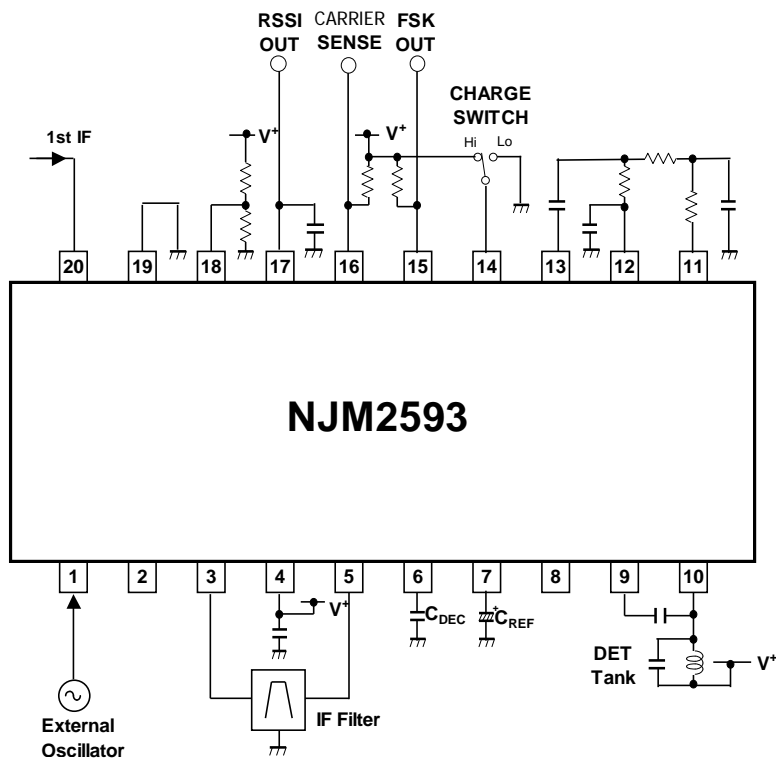

■ EVALUATION PC BOARD

The evaluation board is useful for your design and to have more understanding of the usage and performance of this device. This circuit is the same as TEST CIRCUIT. Note that this board is not prepared to show the recommendation of pattern and parts layout.

● Circuit Diagram

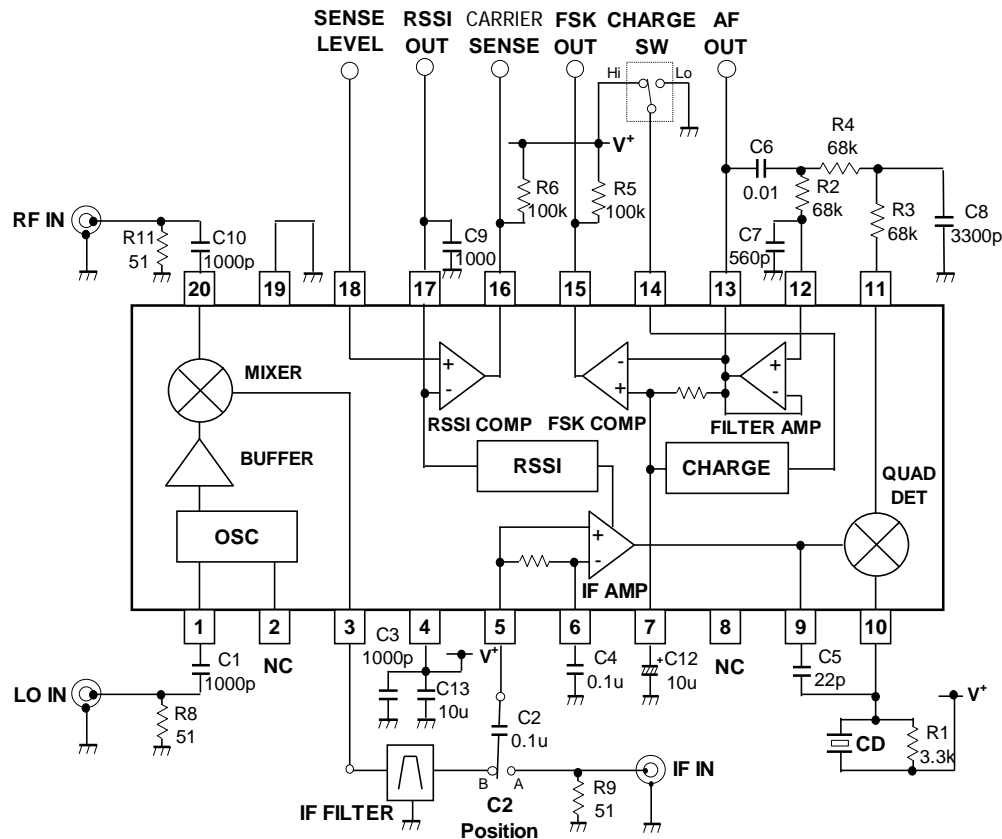

Note:

1. This board is designed for mixer-input type and C2 is factory-configured as follows:
C2 : in the B position
For the case of IF-input type, the position of C2 is necessary to change as follows:
C2 : in the A position
The actual position of C2 is shown in the next page.
2. External components
CD : Ceramic Discriminator, 450kHz
IF FILTER : Ceramic Filter, 450kHz

NJM2593

- Circuit Side View

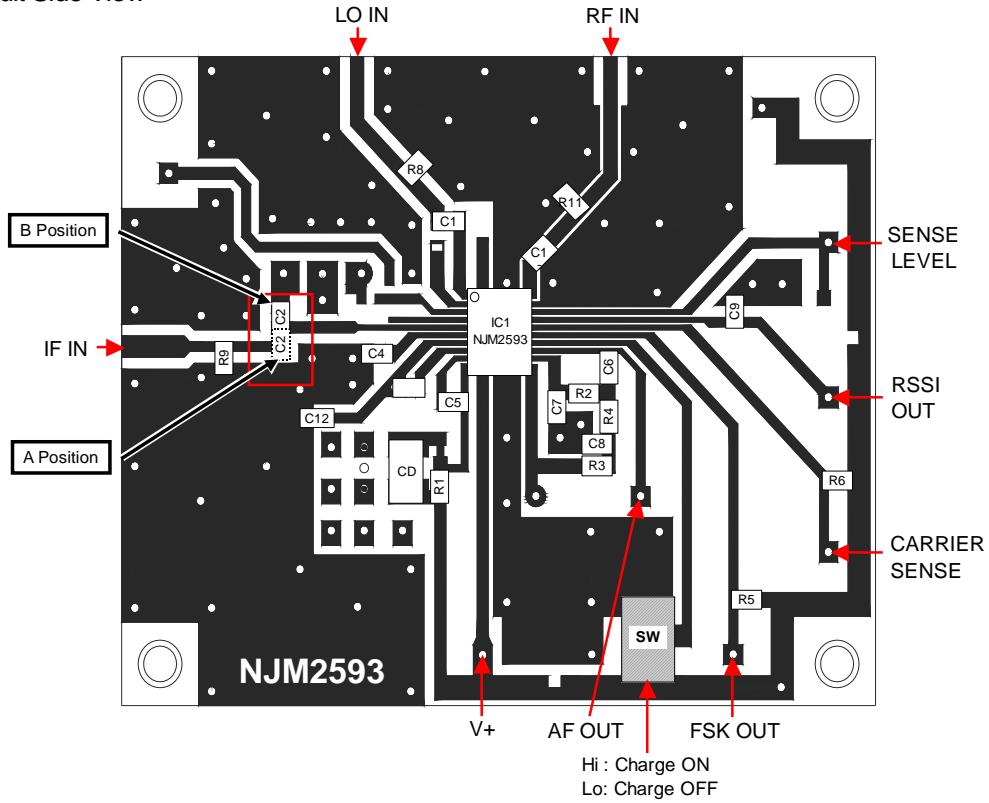

- Ground Side View

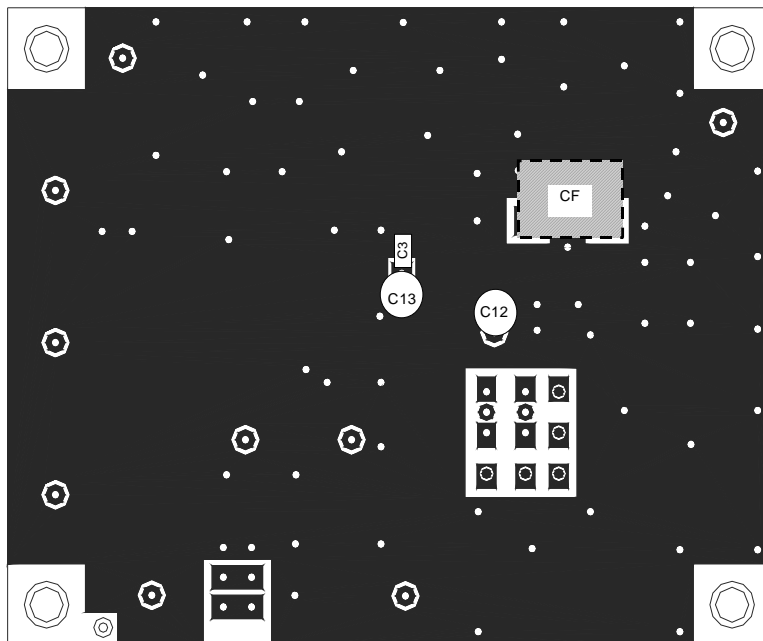

Note:

1. External Components

- C1, C3, C9, C10=1000pF C2, C4=0.1uF C5=18pF C6=0.01uF C7=560p C8=3300pF
 C12, C13=10uF
 R1=3.3kΩ R2, R3, R4=68kΩ R5, R6=100kΩ R8, R9, R11=51Ω
 CF : Ceramic Filter, 450kHz
 CD : Ceramic Discriminator, 450kHz

■ **TYPICAL CHARACTERISTICS (Ta=25°C, V⁺=2.0V, unless otherwise noted)**

Current Consumption versus Supply Voltage

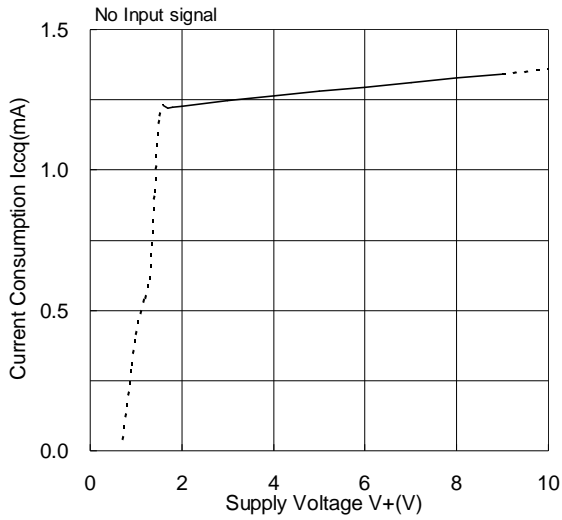

Mixer Conversion Gain versus Supply Voltage

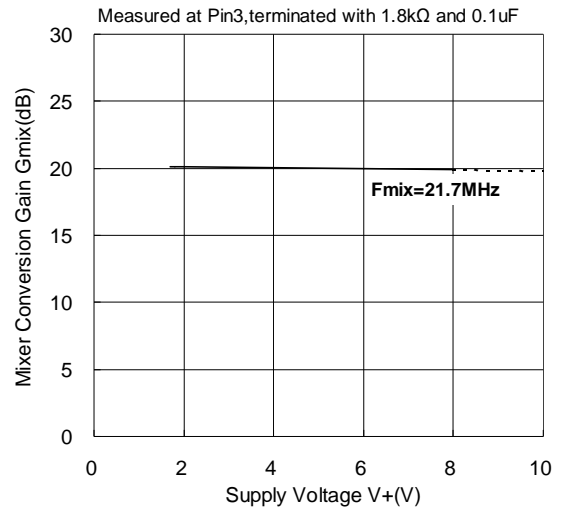

Demodulated Output versus Supply Voltage

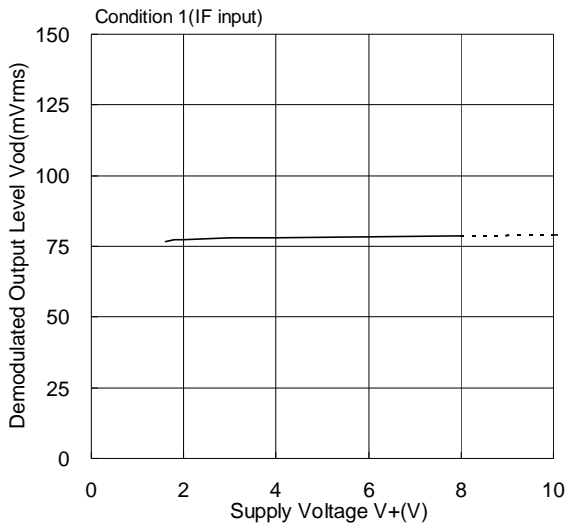

FSK Duty Ratio versus Supply Voltage

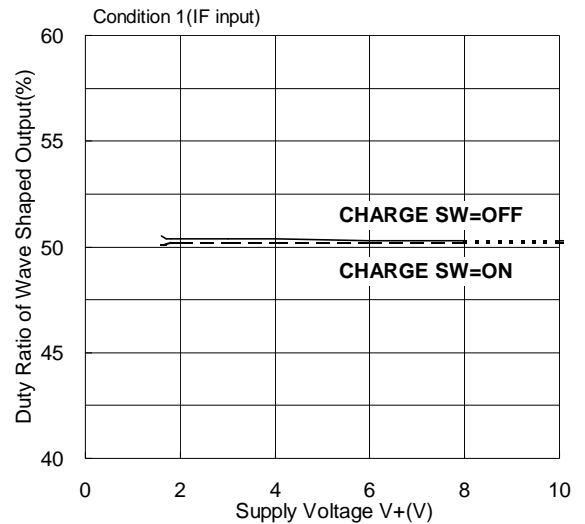

S/N versus Supply Voltage-Mixer Input-

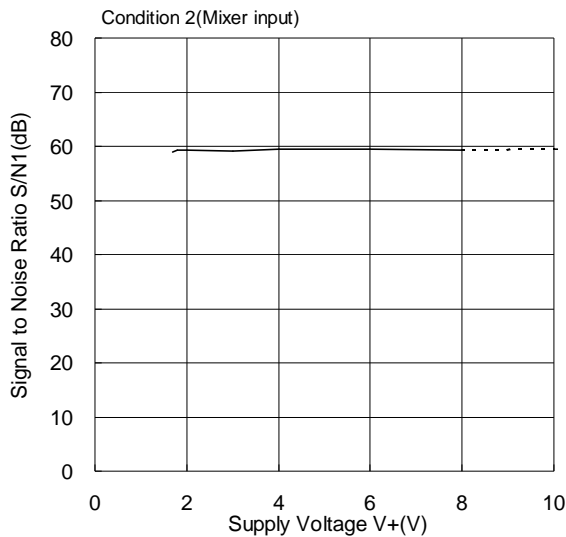

-3dB Limiting Sensitivity versus Supply Voltage

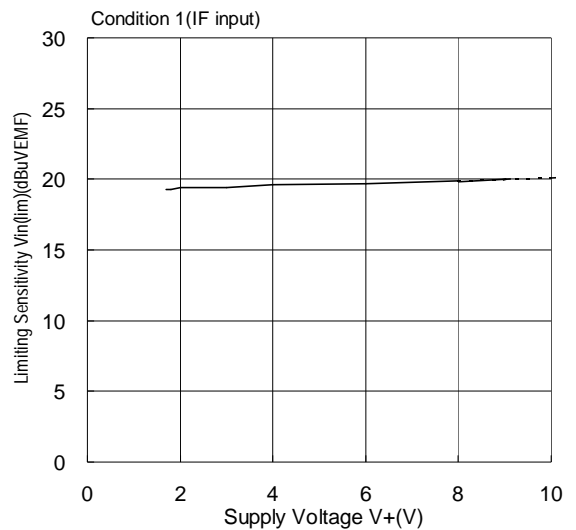

Mixer Conversion Gain versus Frequency

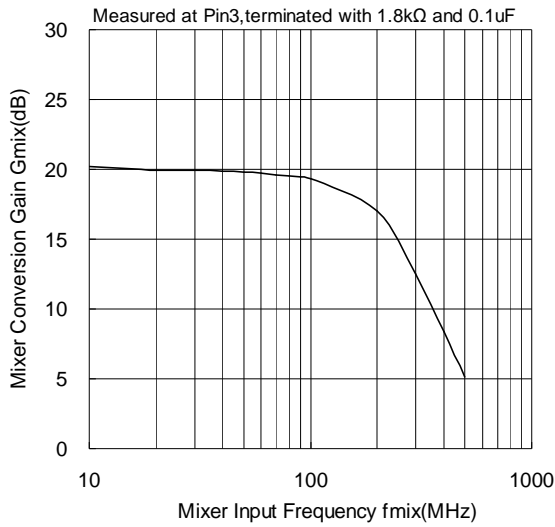

Mixer Conversion Gain versus OSC Input

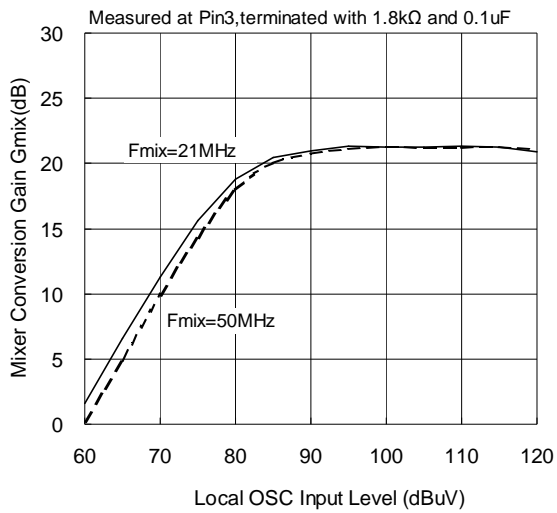

AF Output versus Frequency: S-Curve

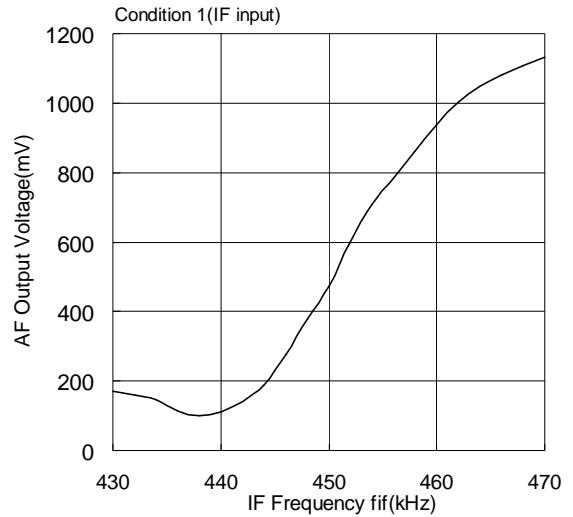

IF Detuning Characteristics

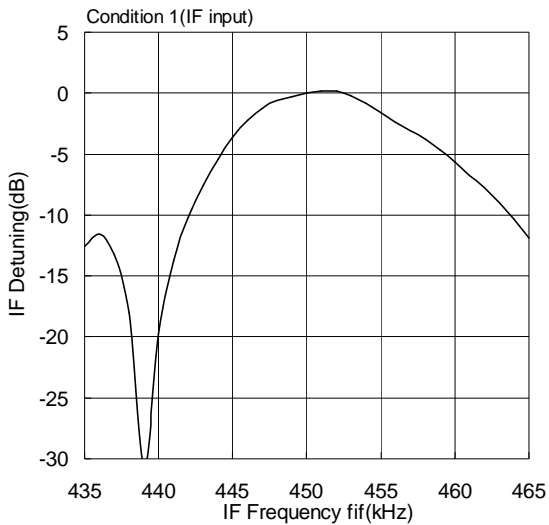

Carrier Sense Characteristics

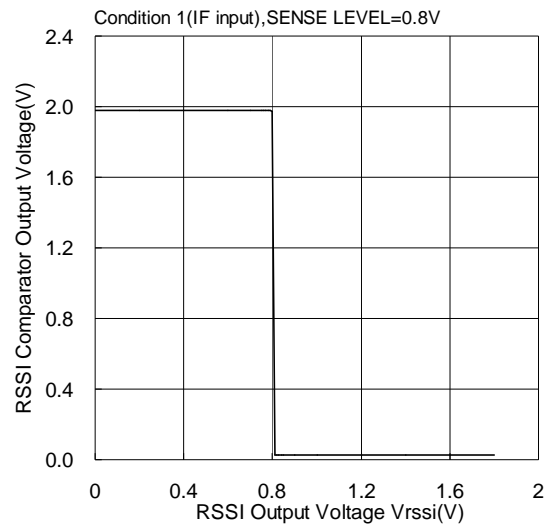

S+N,N,AMR versus Mixer Input

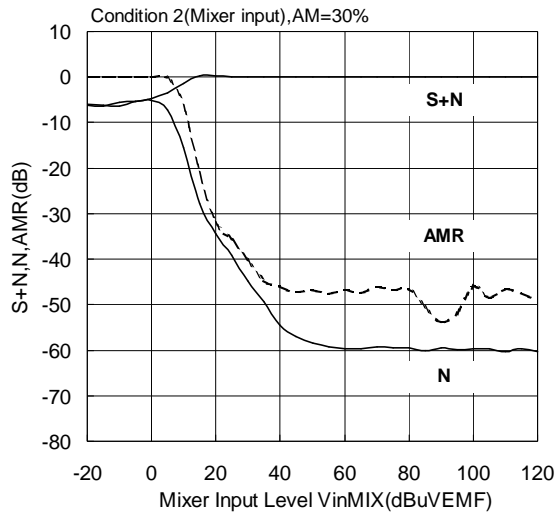

S+N,N,AMR versus IF Input

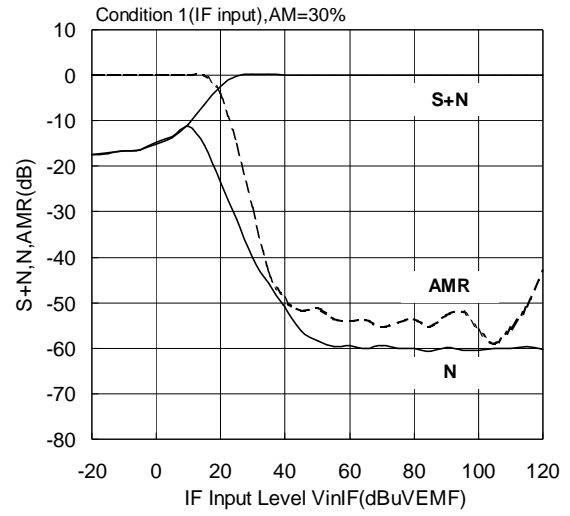

RSSI Output versus Mixer Input

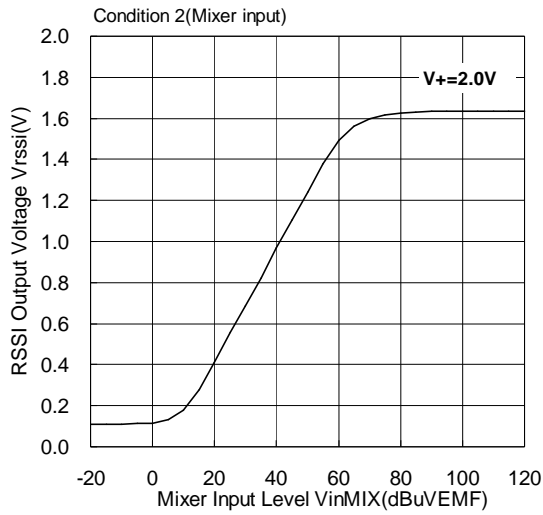

RSSI Output versus IF Input

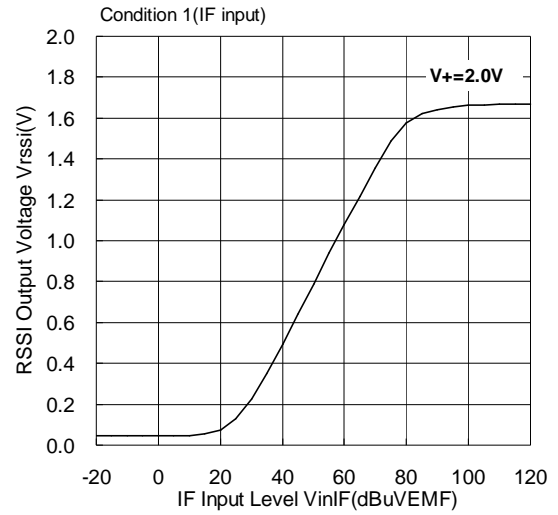

Mixer Conversion Gain versus Temperature

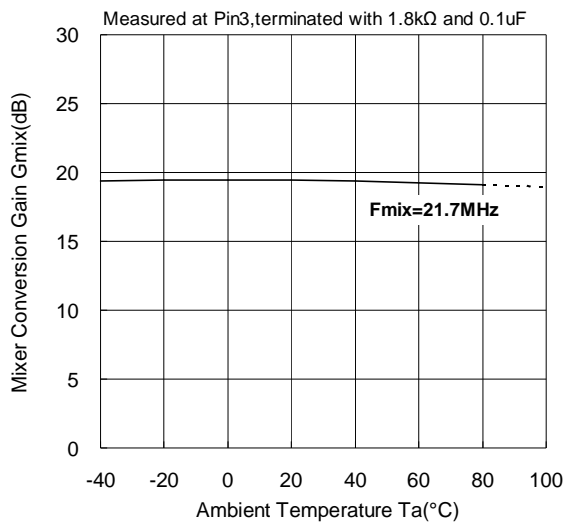

RSSI Output versus Temperature-Mixer-

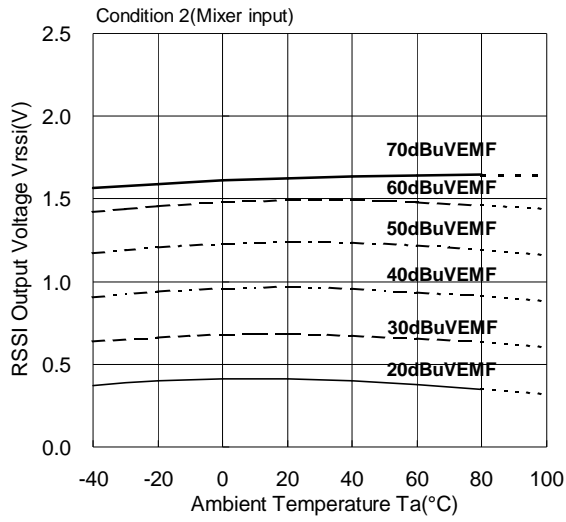

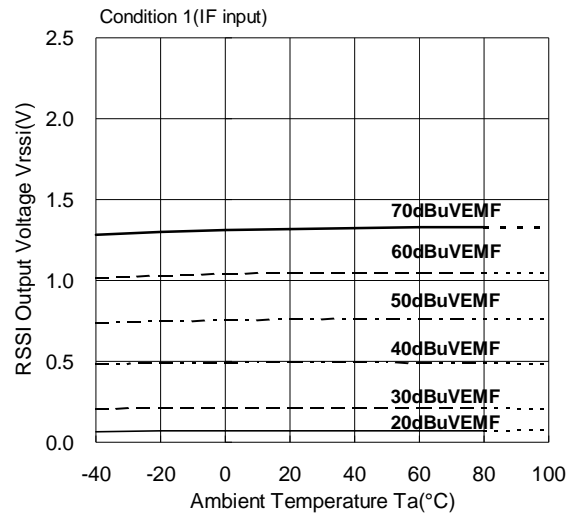

RSSI Output versus Temperature-IF-



[CAUTION]
 The specifications on this databook are only given for information, without any guarantee as regards either mistakes or omissions. The application circuits in this databook are described only to show representative usages of the product and not intended for the guarantee or permission of any right including the industrial rights.

Looking for pricing, stock, or lifecycle information?

Click below to explore more details on WIN SOURCE:

-  [View NJM2593V on WIN SOURCE](#)
-  [NJR Corporation/NJRC Information](#)

Optimize Your Supply Chain with WIN SOURCE Solutions

-  Global Sourcing Solution
-  Obsolete Management
-  Cost Control Management
-  Shortage Management
-  Alternative Solution
-  Excess Inventory Management